

070-34  
82235

## Dynamics and Statics of Nonaxisymmetric Liquid Bridges

J. Iwan D. Alexander, Andrew H. Resnick and L. A. Slobozhanin  
Center for Microgravity and Materials Research, University of Alabama in Huntsville,  
Huntsville, AL 35899

60

### Objectives

- Theoretical and experimental investigation of the stability of nonaxisymmetric and nonaxisymmetric bridges contained between equal and unequal radii disks as a function of Bond and Weber number with emphasis on the transition from unstable axisymmetric to stable nonaxisymmetric shapes.
- Numerical analysis of the stability of nonaxisymmetric bridges between unequal disks for various orientations of the gravity vector
- Experimental and theoretical investigation of large (nonaxisymmetric) oscillations and breaking of liquid bridges.

### Introduction

A liquid bridge, or captive drop, is a mass of liquid held by surface tension between two or more solid supports. Liquid bridges occur in a variety of physical and technological situations and a great deal of theoretical and experimental work has been done to determine axisymmetric equilibria for various disk configurations, bridge aspect ratios and rotations (for example, see [1-6]). There have also been numerous investigations of the dynamics of axisymmetric liquid bridges subject to different excitations (impulses, vibration, etc.). Such investigations have been motivated both by practical considerations and basic scientific interest. Liquid bridges and drops are important factors when considering propellant management in liquid fuel chambers and in the positioning of liquid masses using surface tension forces. In crystal growth, they are associated with the floating-zone growth technique. Their oscillation and relaxation properties can also be used for viscosity and surface tension measurements of molten materials at high temperatures [7]. Pendular liquid bridges occur widely in the powder technology industry and are a major influence on powder flow process and mechanical properties [8]. In porous media flow, liquid-liquid displacement can lead to evolution of pendant and sessile lobes or lenticular bridges. The formation of liquid bridges from the gel that coats lung micro-airways results in occlusion of the bronchioles and is a precursor to respiratory problems and lung collapse [9].

In addition to the above, we note that liquid bridges have been involved in a number of past microgravity experiments. In addition to the primary objectives listed above, our research will provide results useful for the quantitative assessment of g-jitter effects on such experiments.

### Research approach

#### Experiments

The Plateau or neutral buoyancy method [3] works on the following principle: if two immiscible liquids of equal density are configured such that one envelops the other then the curvature of the equilibrium interface is a constant. That is, despite the fact that gravity creates a hydrostatic pressure gradient in each liquid, the interface between the two liquids behaves as if gravitational acceleration is zero. In each liquid the pressure  $p_i$ ,  $i=1,2$ , satisfies

$$\text{grad } p_i^* = 0,$$

where  $p_i^* = p_i + \rho_i gz$ ,  $p_i^*$  is reduced pressure and  $\rho_i$  is the density. At the interface between the two fluids

$$p_1^* - p_2^* = (\rho_1 - \rho_2)gz + 2\gamma K .$$

Here  $K$  is the mean curvature of the surface. When  $\rho_1$  and  $\rho_2$  are equal, the curvature is a constant, and equivalent zero-gravity conditions are obtained. In general, the shapes and stability of liquid bridges are governed by the following dimensionless numbers

$$\begin{aligned}
 Bo &= \Delta\rho R^2 g / \gamma && \equiv \text{Bond number} \\
 V &= V_0 / \pi R^2 L && \equiv \text{relative volume} \\
 \Lambda &= L / 2R && \equiv \text{slenderness} \\
 We &= \Delta\rho R^3 \Omega^2 / \gamma && \equiv \text{Weber number} \\
 K &= R_1 / R_2 && \equiv \text{Ratio of supporting disk radii.} \\
 \phi_1, \phi_2 &&& \equiv \text{lower and upper contact angles}
 \end{aligned}$$

Here  $\Delta\rho$  is the density difference between the liquid bridge and the surrounding liquid or gas,  $R$  is the characteristic length associated with the bridge (usually the radius of the supporting disk),  $g$  is the gravitational acceleration,  $\gamma$  is the surface (or interfacial) tension,  $L$  is the distance between the disks,  $V_0$  is the actual liquid volume and  $\Omega$  is the angular rotation rate of the disks.  $Bo$  is a measure of the ratio of buoyancy to surface tension forces. The Weber number represents a balance between centrifugal and surface tension forces. For a non-zero  $Bo$  the outer bath density can be changed by adjusting the bath composition or temperature [5].

Figure 1 schematically depicts our Plateau chamber. Liquid bridges are formed between rigid sharp-edged 1 cm diameter circular disks. The disks are mounted on supports that allow for independent rotation and lateral and vertical translation. These motions are facilitated through two 3-axis precision motor/drive systems. This provides for vertical oscillation, rotation and small amplitude lateral oscillation (the slip-ring gasket constrains the allowable lateral motion of the lower disk). The upper disk is supported by an injection tube. The disks are made from stainless steel. The bridge liquid is injected or removed through an injection tube which terminates in a 4 mm-diameter hole in the center of the upper disk. A calibrated syringe driven by a variable speed electric motor is used for the injection of a fixed volume of liquid. The bridge is simultaneously lengthened by slowly moving the disks apart to the required separation distance. This distance can be determined to within 1-2  $\mu\text{m}$ . A 3-way purge valve is suitably positioned to trap air bubbles.

Each support can be independently vibrated at frequencies less than 10 Hz. Bridge injection is automated with simultaneous recording of precise volume data ( $\pm 0.1 \text{ mm}^3$ ). We use two imaging methods. Video images are obtained from two orthogonal cameras. A high quality Fourier transform imaging system is used for edge detection. The important physical parameters are the aspect ratio of the bridge, the liquid volume and the static and dynamic Bond numbers. The liquid volume and the slenderness (aspect ratio) of the bridge depend on the precision with which lengths can be determined. The disk diameters are known to within 10  $\mu\text{m}$ . The length of the bridge is set by the positioning device and can be determined with a precision of 1-2  $\mu\text{m}$ . Thus, for bridges of 2.5 cm length the slenderness,  $\Lambda = L/2R_0$ , can be determined to within  $\pm 0.04\%$ . Volume can be measured with a precision of 0.1  $\text{mm}^3$  and an accuracy of 0.1%. The liquid bath is a methanol-water solution. Variation of the methanol concentration changes the density difference between the Dow Corning 200<sup>®</sup> silicone oil bridge and the bath. We control the bath temperature and change the methanol concentration to adjust  $Bo$ . At 83% water concentration a condition of neutral buoyancy is obtained.

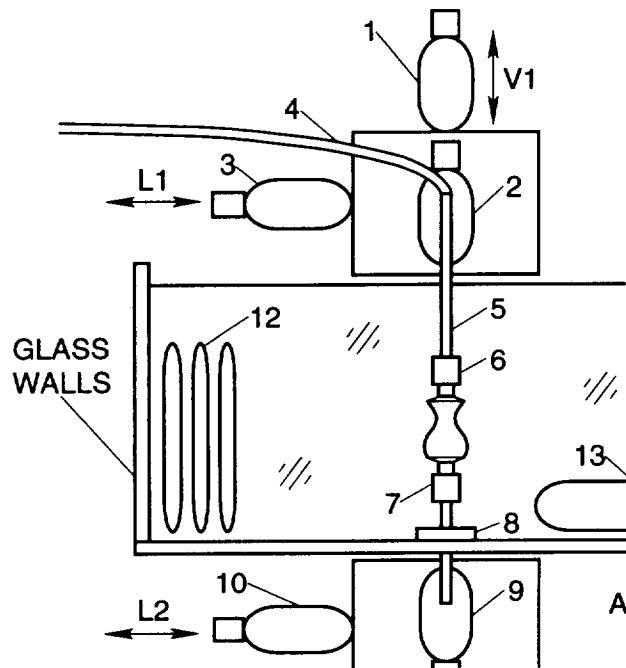

Fig. 1 Plateau Chamber: (1) upper vertical displacement motor  $V1$ ; (2) upper rotational motor; (3) upper lateral displacement motor,  $L1$ ; (4) bridge fluid injection line; (5) upper spindle; (6) upper feed disk; (7) lower feed disk; (8) slip-ring gasket; (9) lower rotational motor; (10) lower lateral displacement motor,  $L2$ ; (11) lower vertical displacement motor  $V2$ ; (12) cooling coils; (13) bath circulator.

### ***Theoretical work***

Our theoretical work will focus on the numerical modeling of the oscillation and breaking of bridges subject to axial and lateral forcing. The problem of stability of bridges subject to steady axial and nonaxial gravity will be examined through a combination of analytical and numerical work (see discussion below).

### ***Results to date***

#### *Stability of nonaxisymmetric configurations subject to axial and nonaxial gravity.*

We have examined the stability of nonaxisymmetric shapes of liquid bridges (with a fixed volume  $V_0$ ) held between equidimensional coaxial disks of radius  $R$ . The disks are separated by a distance  $L$  and subject to lateral acceleration. We employed *Surface Evolver* [11] to find the minimum energy configurations of the bridges. In comparison, for axisymmetric bridges subject to axial gravity, the stability limits correspond to a situation when the axisymmetric bridge breaks, or when the axisymmetric bridge loses stability to a stable nonaxisymmetric shape. The lateral acceleration stability limit is defined solely in terms of loss of stability by breaking. This limit is determined for both large and small values of the relative volume. The stability limit can be divided into two basic segments (stable regions are to the left of the curves, see Fig. 2). One segment appears to be indistinguishable from part of the margin for the zero-Bond number case. The other segment belongs to a one-parameter ( $Bo$ ) family of curves which, for a given  $Bo$  and a fixed value of  $\Lambda$ , have a maximum and minimum stable relative volume. Each of these curves is asymptotic to another part of the minimum volume zero-Bond number limit up to a point determined by the particular value of  $Bo$  and has a turning point corresponding to a maximum value of  $\Lambda$ . For  $V \gg 1$ , the maximum volume stability limit tends to infinity as  $\Lambda \rightarrow 0$ . For any given lateral Bond number, the minimum volume

stability limit is decreased and becomes indistinguishable from the zero Bond number limit when  $\Lambda$  becomes sufficiently small. For unstable bridges in the vicinity of the stability limit a consistent sequence of shapes can be readily identified and are recognizable by their overall shape and the number of necks.

In a recent bifurcation analysis for  $V = 1$  bridges subject to lateral gravity (Laveron et al. [10]) it was speculated that, because the eigenfunction associated with a subcritical bifurcations for  $\Lambda > \Lambda_c$  is antisymmetric with respect to the  $z = 0$  plane, the bridge would break into two drops of unequal volumes. Likewise it was speculated that, for  $\Lambda < \Lambda_c$ , loss of stability would lead to equal size drops since destabilization occurs through a turning point and the associated eigenfunction is symmetric. Our results confirm this, although we note that, when breaking occurs, three drops form. Two of these remain attached to the disks while the third is a smaller, free, satellite drop.

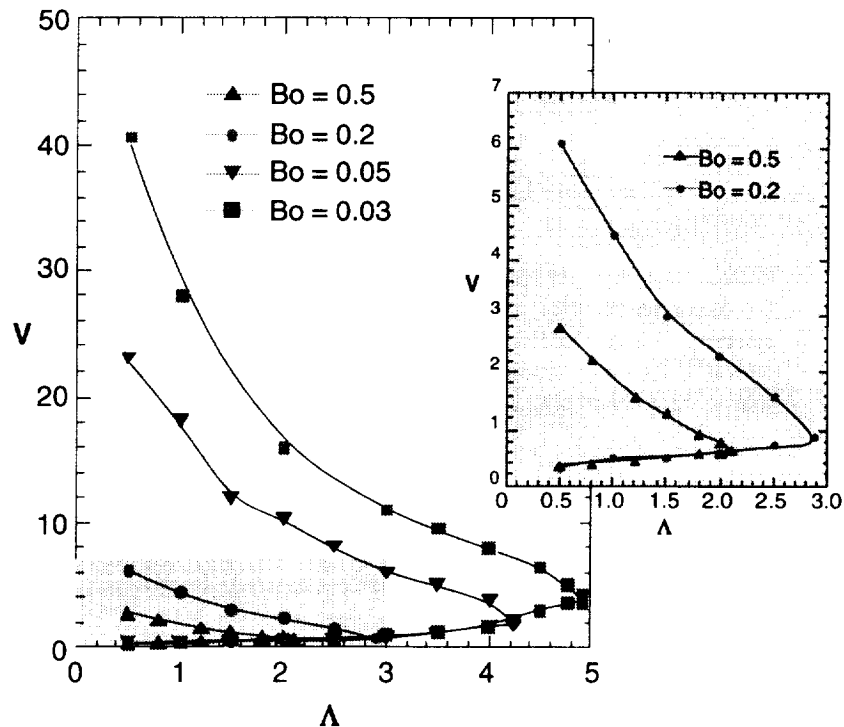

Fig. 2 Stability limits of liquid bridges held between equidimensional coaxial circular disks and subject to lateral gravity. (Points shown are stable bridges close to the stability limit). From [12].

#### *Stability of equilibrium of axisymmetric bridges subject to arbitrary perturbations*

The stability problem for an isorotating bridge between equal disks in an axial gravity field has been solved under constraints typical for the materials purification processes and growth of single crystals by the floating zone technique. For the constraint that the relative volume,  $V$ , is equal to 1, the critical values of the slenderness,  $\Lambda$ , have been determined for a wide range of the  $Bo$  and  $We$  numbers. For a prescribed value of the liquid contact angle at the upper or the lower disk (the chosen values correspond to growing angle values of  $0^\circ$  and  $15^\circ$ ), the dependencies of critical  $\Lambda$  and  $V$  values on  $Bo$  and  $We$  have been calculated. The influence of unequal radii disks on the boundary of the stability region in the  $(\Lambda, V)$ -plane has also been investigated for the case of finite axial gravity [13]. Unlike earlier work, arbitrary (not only axisymmetric) perturbations are accounted for and the entire stability boundary is constructed. The approach taken is

described in [14]. This work is still in progress and selected results will be presented at the workshop.

### ***Numerical modeling***

When a liquid bridge is at, or exceeds, its stability limit it will either change its shape, (for example, from an axisymmetric to a nonaxisymmetric shape) detach from the support disks, or break up into smaller drops. The process of breaking involves the decay of the bridge radius to zero at some points. When this occurs the bridge separates. This means that the governing equations must be singular at this point. Linear stability theory fails to describe this situation adequately and cannot predict the shape of the surface as breaking is approached, nor does it account for the non-uniform break-up of the bridge, i.e. that separation of the bridge into two or more large drops is accompanied by the formation of much smaller "satellite drops". The breaking of liquid bridges has been studied using 1D models [15]. Numerical treatment of the breaking of liquid jets beyond the singularity has been studied recently by Eggers and Dupont [16] using a 1D model, and Shulkes [17] has compared the predictions of 1D models of inviscid bridges as breaking is approached with the results of a 2D axisymmetric velocity-potential calculation for which no simplifying assumptions were made. At early times the differences between the three are small, however, as the bridge deformation became severe, the 1D models deviated significantly from the trends exhibited by the 2D velocity-potential results. The major shortcomings of 1D models are their inability cope with the bending of the bridge well below the lower disk edge. The velocity-potential model was able to handle this degree of deformation. Recently, we have applied a modified Volume of Fluid (VOF) method to the dynamical problem of breaking of viscous axisymmetric and non-axisymmetric bridges. Selected results will be presented at the workshop.

### ***References***

- [1] Mason, G. C., An experimental determination of the stable length of cylindrical liquid bubbles, *J. Colloid Interface Sci.* 32 (1970), 172-176.
- [2] Meseguer, J. & Sanz, A., Numerical and experimental study of the dynamics of axisymmetric liquid bridges, *J. Fluid Mech.* 153 (1985), 83-101.
- [3] Meseguer, J., Mayo, L. A., Llorente, J. C. & Fernández, A., Experiments with liquid bridges in simulated microgravity, *J. Crystal Growth* 73 (1985), 609-621.
- [4] Bezdenezhnykh, N. A. & Meseguer, J., Stability limits of minimum volume and breaking of axisymmetric liquid bridges between equal disks. Presented at the International Symposium on Hydromechanics and Heat/Mass Transfer in Microgravity (1991), Perm.
- [5] Sanz, A., 1985 The influence of the outer bath on the dynamics of axisymmetric liquid bridges, *J. Fluid Mech.* 156 (1985), 101-140.
- [6] Meseguer, J., Stability of slender, axisymmetric liquid bridges between unequal disks, *J. Crystal Growth* 67 (1984), 141-143.
- [7] Tsamopoulos, J., Chen T. & Borkar, A., Viscous oscillations of capillary bridges, *J. Fluid Mech.*, 225 (1992) 579-609.
- [8] Ennis, B.J., Li, J., Tardos, G. & Pfeffer, R., The influence of viscosity on the strength of an axially strained pendular bridge, *Chem. Eng. Sci.*, 45 (1990) 3071-3088.
- [9] Newhouse, L. A. & Pozrikidis, C., The capillary instability of annular layers and thin liquid threads, *J. Fluid Mech.*, 242 (1992) 193-209.
- [10] Laveron, A. & Perales, J.M., Equilibrium shapes of nonaxisymmetric liquid bridges, *Phys. Fluids*, 17 (1995) 1204-1213.
- [11] Brakke, K. *Experimental Mathematics*, 1 (1992) 141.
- [12] Alexander, J.I.D., Delafontaine, S. & Carter, C., Stability of liquid bridges subject to lateral acceleration, to be published (1996).

- [13] Slobozhanin, L., Alexander, J.I.D. & Resnick, A.H., Stability of liquid bridges under low gravity conditions, to appear in the Proceedings of the 2nd Symposium on Fluids in Space, Naples, Italy, 1996.
- [14] Myshkis, A.D., Babskii, V.G, Kopachevskii, N.D. Slobozhanin, L.A. & Tyuptsov, A.D., Low Gravity Fluid Mechanics (1987) Springer Verlag, Berlin.
- [15] Meseguer, J., The breaking of axisymmetric slender liquid bridges, *J. Fluid Mech.* 130 (1983) 123-151.
- [16] Eggers, J. & Dupont, T.F., Drop formation in a one dimensional approximation of the Navier-Stokes equations, *J. Fluid Mech.* 262 (1994) 205.
- [17] Shulkes, R.M.S.M., Nonlinear dynamics of liquid columns: A comparative study, *Phys. Fluids A* (1993) 2121-2130.