

526-37
50454
125140
P 6

A Computer Controlled Power Tool for the Servicing of the Hubble Space Telescope

Paul W. Richards^{*}, Carl Konkel^{**}, Chris Smith^{**},
Lee Brown⁺ and Ken Wagner^{*}

Abstract

The Hubble Space Telescope (HST) Pistol Grip Tool (PGT) is a self-contained, micro-processor controlled, battery-powered, 3/8-inch-drive hand-held tool (Figure 1). The PGT is also a non-powered ratchet wrench. This tool will be used by astronauts during Extravehicular Activity (EVA) to apply torque to the HST and HST Servicing Support Equipment mechanical interfaces and fasteners. Numerous torque, speed, and turn or angle limits are programmed into the PGT for use during various missions. Batteries are replaceable during ground operations, Intravehicular Activities, and EVAs.

Introduction

Before each HST Servicing Mission the PGT is programmed via an RS-422 or RS-232 interface. Fourteen torque settings and three speed settings can be programmed for each mission. A specific number of turns or angle can also be programmed with each torque setting. The programmed torque range is 2.7 - 33.9 N•m (2.0 - 25.0 ft•lbf); the programmed speed range is 0.5 - 6.3 rad/s (5.0 - 60.0 rpm), and the available turn settings are 0.01 - 999.99 rotations or 1 - 1000 deg. Other programmable variables include stall time, sleep time, auto off time, torque thresholds, and angle thresholds. Integral to the PGT is a Multisetting Torque Limiter (MTL), which is a mechanical device for protecting hardware from the application of excessive torque. The MTL has 6 settings that are ground re-configurable before each mission. The MTL torque range is 1.4 - 67.8 N•m (1.0 - 50.0 ft•lbf).

Overview

The PGT is grouped into Functional Subsystems and physical Assembly Modules. The five Functional Subsystems are: Mechanical, Electrical, Battery, Software, and Operator Interfaces. There are five Assembly Modules: MTL, Power Train, Main Housing, Electronics Module, and Battery Module. A cutaway view of the PGT can be seen in Figure 2.

A modular design simplifies assembly and maintenance and can be utilized during troubleshooting by exchanging modules with other PGT units. Each module can be installed and removed as a separate subassembly. All modules are fastened to the

^{*} NASA, Goddard Space Flight Center, Greenbelt, MD

^{**} Orbital Sciences Corporation, Greenbelt, MD

⁺ Swales and Associates, Inc., Beltsville, MD

Main Housing directly or through another module. The Battery Module is secured within the Main Housing battery shroud using a locking mechanism.

Functional Subsystems

Mechanical Subsystem

The Mechanical Subsystem provides the necessary mechanisms and structure needed to apply output torque. The Assembly Modules with a majority of components from the Mechanical Subsystem include the MTL, Power Train, and Main Housing.

Electrical Subsystem

The Electrical Subsystem provides the analog and digital functions as well as the platform required for software and computer control. This fault-tolerant, re-programmable electronic subsystem consists of the Electronics Module as well as the ON/OFF circuit breaker, the A/B mode switch, and the DC/DC converter. The challenge was to package this motor control system, along with a 25-measurement signal conditioning system, an 8-channel/10-bit data recording system, and a reliable power supply into a volume of 245 cm³ (15 cubic inches). This challenge was met using proven state-of-the-art electronic design and assembly techniques, including an all-digital control scheme, multi-function microcontroller, off-the-shelf hybrid microcircuits, programmable logic, and two-sided surface mount technology.

Battery Subsystem

The Battery Subsystem which provides the power for the PGT consists of the self-contained Battery Module. The requirements for the Battery Subsystem were to maintain at least 28V with a 1A continuous current for the electronics and 8.25A pulse current discharge for the motor. As a goal, sufficient capacity for an entire 6 hour EVA was desired. These requirements also have to be met at the worst-case thermal conditions for the HST Servicing mission.

Selecting the proper battery technology and cell size to meet these requirements yet keeping the battery small enough for an astronaut to translate with the PGT was a difficult process. Four technologies; Nickel-Cadmium (NiCd), Nickel-Metal-Hydride (NiMH), Lithium-Ion (Lilon), and Silver-Zinc (AgZn), were identified as potential PGT Battery technologies. Of the four candidates, Lilon cells possess the highest combination of cell voltage and volumetric energy density. The PGT Battery Module will be the first space qualified Lilon battery.

The Software of the PGT computer implements three major functions; Servo-System, Fault Detection, Data Collection. The Servo-System is a closed loop feedback system which limits the torque, speed and the angle output of the PGT. The control is based upon Proportional and Integral control algorithm using pulse width modulation and the knowledge of the native motor speed/torque curve. The software will allow the motor to function at the lesser of three conditions; programmed torque, programmed speed, or the maximum output based upon the native speed/torque curve. The computer system also collects and stores fault data, diagnostic data, and performance data. The various faults that can be detected are Software, Temperature, Current,

Voltage, and Torque. The fault history is stored in non-volatile memory to allow for trouble shooting during development, testing, and use.

Operator Interfaces

The Operator Interface Subsystem provides the means for all necessary operator input and provides visual feedback through markings, an alphanumeric display, and status and warning light emitting diodes (LEDs). The operator selects the configuration of the PGT through various switches and collars. The selection collars include the MTL Torque collar, Ratchet collar, Programmed Torque collar, and the Speed collar. The Speed collar also has a CAL setting which tests the LEDs, the Alphanumeric Display and calibrates the torque transducer. The switches include the ON/OFF circuit breaker, the A/B Mode switch, and the trigger.

Configuration, performance, and fault information is shown to the operator via the LEDs and Alphanumeric Display. The LEDs consist of the POWER (green), FAULT (red), and TORQUE (green/red). The Alphanumeric Display shows the programmed torque, programmed speed, direction, actual peak torque, and actual cumulative rotation since the last configuration change. Fault messages are also presented to the operator in the Alphanumeric Display.

Assembly Modules

Multisetting Torque Limiter (MTL)

The MTL, located at the forward end of the PGT rotates with the output shaft. There are six torque settings which are ground re-configurable before each mission. The MTL torque range is 1.4 - 67.8 N•m (1.0 - 50.0 ft•lbf). Each setting increases the torque of the previous setting by 1.4 - 20.3 N•m (1.0 - 15.0 ft•lbf). The highest value implemented will be 41.3 N•m (30.5 ft•lbf), which is the maximum design limit of the PGT in the manual mode. The torque settings are selected by the operator by unlocking the thumb switch and rotating the MTL torque selector collar. The thumb switch prevents inadvertent reconfiguration of the MTL.

Power Train

The PGT Power Train consists of the motor, gearing, and torque transducer, and ratchet/clutch mechanism. The PGT motor is a 28V, four pole, brushless dc motor. The motor uses samarium cobalt magnets on the rotor and employs hall effect sensor commutation. The gearing is a 2-stage planetary gear set with a reduction ration of 110:1.

The operator selects the motorized or manual mode of the output shaft by rotating the ratchet collar and aligning the visual indicator with the desired setting. There are three settings: Ratchet Clockwise (RCW), Motorized (MTR), and Ratchet Counterclockwise (RCCW). In the MTR setting a clutch is engaged and the motor output shaft is connected through the MTL which to the PGT output shaft. In the RCW and RCCW settings the clutch is disengaged and either the clockwise or counter-clockwise ratchet pawl is engaged. When in either the RCW or RCCW settings, the load path is through the ratchet pawl to the Main Housing. There is also a hall effect sensor electrical inhibit, which allows motorized operation in the MTR mode, but inhibits motorized

operation in the RCW and RCCW mode. This inhibit prevents motor operation during inadvertent contact with the trigger.

Main Housing

The Main Housing consists of the Collar/Switch Subassembly, and a two-piece housing, which consists of the Power Train housing, the handle and trigger and the battery shroud. The Collar/Switch Subassembly contains the Speed collar, Torque collar, ON/OFF circuit breaker switch, A/B mode switch, and the DC/DC Converter.

Electronics Module

The Electronics Module consists of an analog circuit board and a digital circuit board mounted in an aluminum housing. The major components of these boards are a 87C196KD microcontroller, a Clock Oscillator, Memory Address Latches, EEPROM, a Erasable Programmable Logic Device (EPLD) EMP5130, 82C55 port expander, DAC-8412 quad digital to analog converter, Strain-gauge Torque Transducer signal conditioning circuit, temperature (Motor, Battery and Motor-drive Hybrid) signal conditioning circuits, Hardware Torque Warning Circuit, Latch-up current-limiting circuits, and a Motor Drive Hybrid circuit.

Battery Module

Each PGT Battery Module contains ten Lilon cells connected in series to create a 41V open circuit and a 36V nominal closed circuit battery. The battery design was optimized to approximately 2.4 A•hr capacity using modified C sized cell. The cell pack is then packaged into a nickel-plated aluminum housing. A cover is fastened on top to form the battery module. On one end of the module is a rectangular sub-miniature connector which provides an interface to the tool for positive and negative power lines. A 10A fuse on the negative line provides over-current protection in the event of a short in the tool. The battery modules and the battery shroud are keyed with alignment grooves to prevent incorrect insertion.

The battery module design includes a temperature sensor to sense battery/cell temperature. If battery temperature increases to above nominal level, the Alphanumeric Display will indicate a high battery temperature warning to the user. If battery temperature increases and approaches an unsafe level, a software command is given to remove power using the circuit breaker.

Conclusion

The application of satellite mechanism technology and design methods was critical in the production of a compact, ergonomic power tool which meets the accuracy, reliability, and safety requirements for the HST Second Servicing Mission.

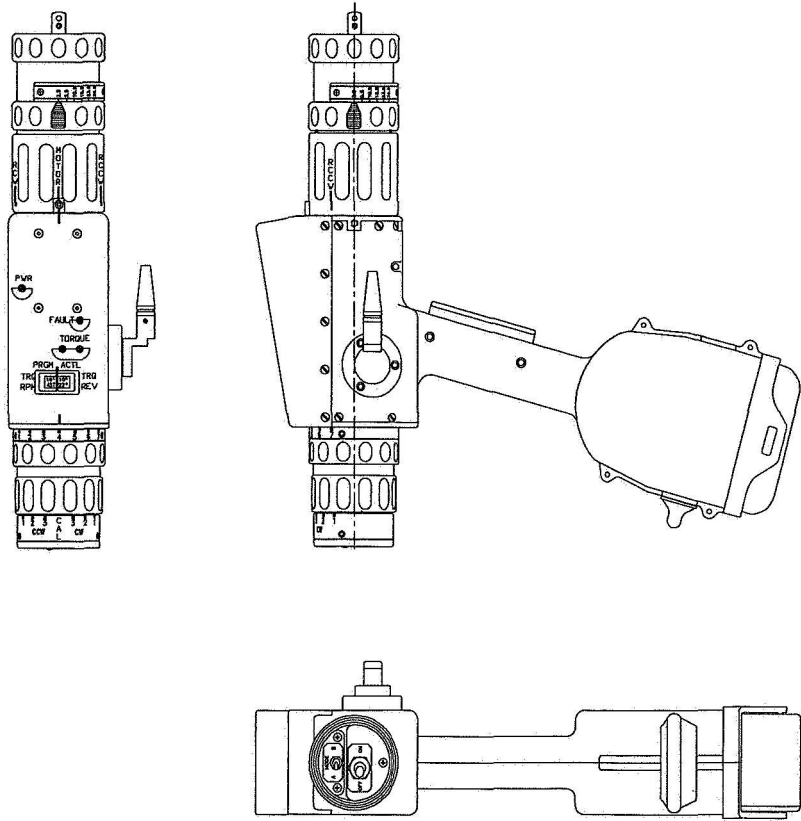

Figure 1
Pistol Grip Tool
External View

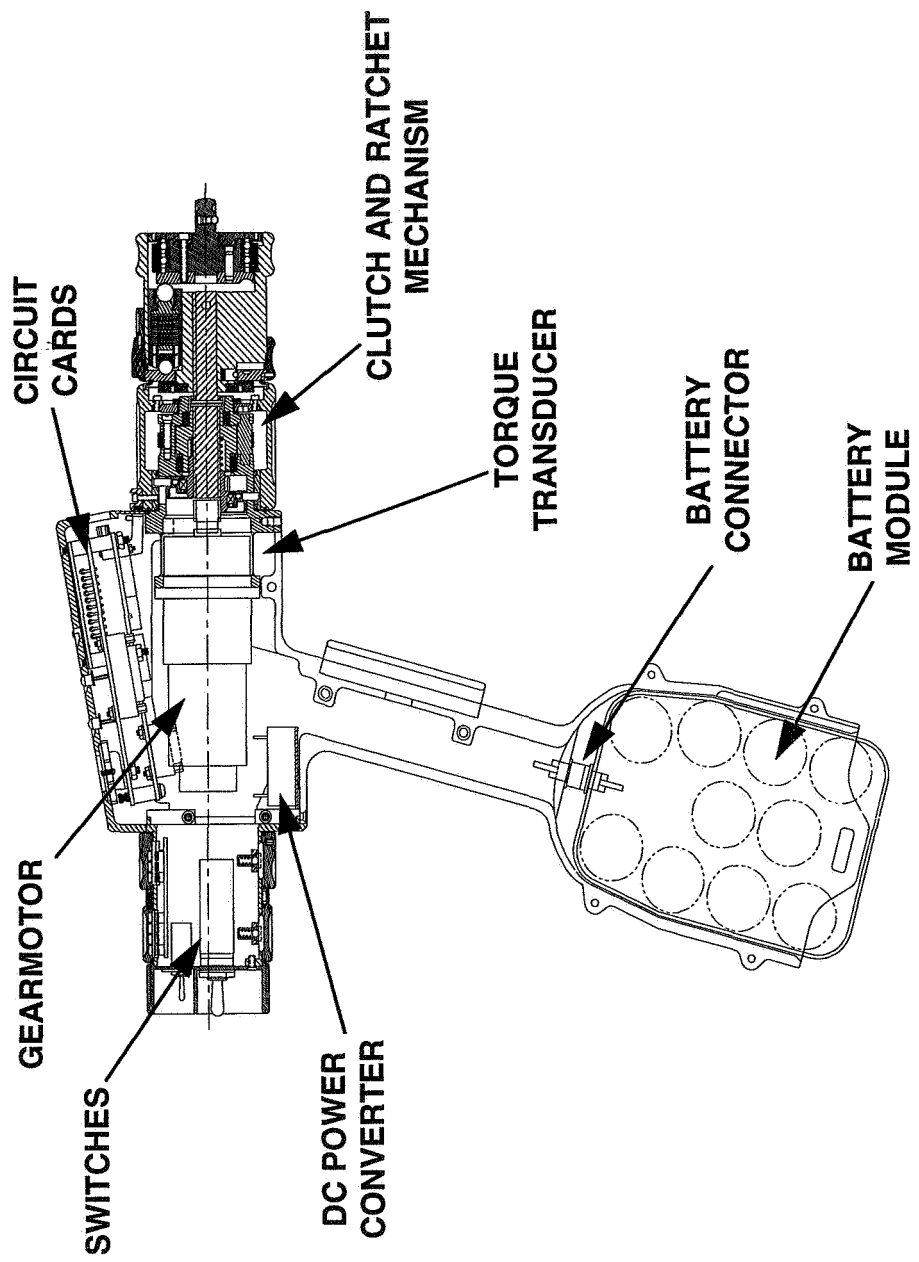

Figure 2
 Pistol Grip Tool
 Cutaway View