

58-37 ✓
50436
125122
P 10

A Nitinol-Based Solar Array Deployment Mechanism

Shin John Choi*, Chia-Ao (Bill) Lu*, and John Feland*

Abstract

This document describes a simple, light weight, and scalable mechanism capable of deploying flexible or rigid substrate solar arrays that have been configured in an accordion-like folding scheme. This mechanism is unique in that it incorporates a Shape Memory Alloy (SMA) actuator made of Nitinol. This paper documents the design of the mechanism in full detail while offering to designers a foundation of knowledge by which they can develop future applications with SMAs.

Introduction

Solar array deployment technology has reached a high level of sophistication via the use of traditional mechanical means such as linkages, motors, springs, and dampers. Although proven reliable and effective, many deployment means have been found to have high weight penalties. In an effort to reduce the weight and complexity of deployment mechanisms, a simple, Nitinol-driven deployment means was developed.

The mechanism described in this paper is the result of a 25 week collaborative effort between Stanford University and Lockheed Martin Missiles and Space. The development effort took place within the context of a graduate level, project based design course called Cross Functional Systems Design (ME210). The objective of the project was not to deliver a flight-ready mechanism, but rather to explore the possibility of applying shape memory technology to solar array deployment.

Shape Memory Alloys and Nitinol

Background

Shape Memory Alloys are a class of materials with the peculiar property of being able to "remember" a specific shape. SMAs can be deformed and then returned to their original shape when heated beyond a specific temperature known as its transition temperature. The two most common types of SMAs are NiTi and CuZnAl. Nitinol is a trade name for Nickel Titanium (NiTi) alloy.

The Shape Memory Effect

The key to the shape memory effect is a change in the crystalline structure of the material. Above its transition temperature, it is an ordered cubic structure known as Austenite. Below the transition temperature, it is in a monoclinic phase called Martensite. The crystals in the monoclinic phase are tilted in opposing bands so that the structure appears as a "squashed" cubic structure. When it is deformed, the material does not act like a normal metal. Rather than deform through dislocation movement, the crystal bands bend and align themselves in one direction or the other.

* Mechanical Engineering Design Division, Stanford University, Stanford, CA

When the crystalline structure is heated beyond its transition temperature, the “squashed” monoclinic crystals expand back into the ordered cubic state, thereby reversing any deformation done in the martensitic state. When heat reverses the deformation, it returns to the austenitic form set during the training process. This phenomenon is known as one-way memory. Figure 1 shows what happens between the two states. The material can, under specific conditions, be trained to have shape memory in both the austenitic and martensitic states. This is referred to as two-way memory. Discussion on two-way memory is beyond the scope of this paper.

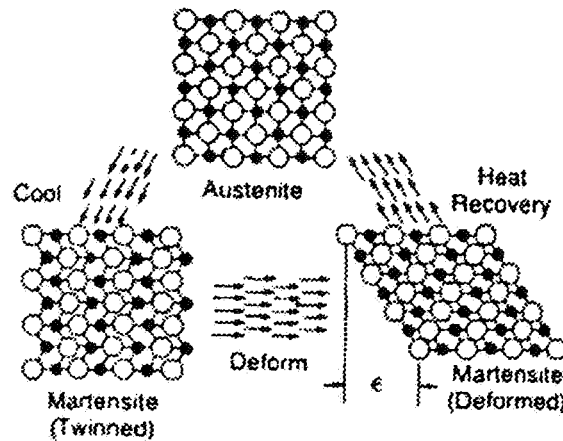

Figure 1. Representation of the changes in the crystalline form of Shape Memory Alloys that give it the memory characteristic.

Properties of Nitinol (NiTi)

Table 1 summarizes the physical, mechanical, and transformation properties of the material. Note in particular the wide range in the yield strength of the material. The wide range in the mechanical properties is explained by the strong dependence of the material composition to temperature. The ratio of martensite to austenite in the material at temperatures close to its transformation determines its exact properties. Figure 2 shows stress-strain curves for Nitinol at its fully austenitic (T1) and fully martensitic (T2) states.

Stress-Induced Martensite: Obtaining More Travel

There is a unique and subtle change in the behavior of SMAs when they cool and transition from the austenitic to martensitic state. The transition between these states during cooling is marked by a dramatic change in material properties. This change in material properties is very important in that it allows much easier and effective use of the material as an actuator.

As the material cools from martensite to austenite, the material’s yield strength and elastic modulus do not merely change in a smooth, linear fashion. It was found that both of these properties drop far below their martensitic material values when loaded

Table 1. The physical, mechanical, and transformation properties of NiTi, the most commonly used Shape Memory Alloy.^a

| | |
|-------------------------------------|--|
| Melting Point | 1300°C |
| Density | $6.45 \times 10^3 \text{ kg/m}^3$ |
| Electrical Resistivity (austenite) | $\sim 100 \mu\Omega\cdot\text{cm}$ |
| Electrical Resistivity (martensite) | $\sim 70 \mu\Omega\cdot\text{cm}$ |
| Thermal Conductivity (austenite) | $0.18 \text{ W/cm}\cdot^\circ\text{C}$ |
| Thermal Conductivity (martensite) | $0.085 \text{ W/cm}\cdot^\circ\text{C}$ |
| Corrosion Resistance | Similar to 300 series Stainless or Ti Alloys |
| Specific Heat | $0.20 \text{ cal/g}\cdot^\circ\text{C}$ |
| Young's Modulus (austenite) | $8.27 \times 10^7 \text{ kPa}$ |
| Young's Modulus (martensite) | $2.76\text{-}4.14 \times 10^7 \text{ kPa}$ |
| Yield Strength (austenite) | $1.93 \times 10^5 \text{ kPa}$ |
| Yield Strength (martensite) | $6.89 \times 10^5 \text{ kPa}$ |
| Ultimate Strength | $8.96 \times 10^5 \text{ kPa}$ |
| Elongation at Failure | 20-40% |
| Transformation Temperature | -200 to 110°C |
| Latent Heat of Transformation | 5.78 cal/g |
| Shape Memory Strain | 8.5% maximum |

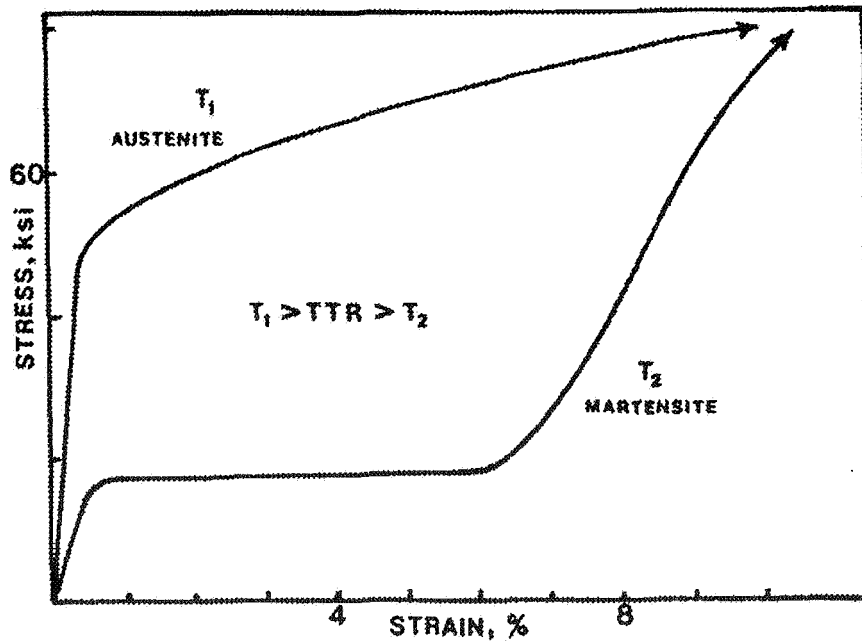

Figure 2. The stress-strain relations for NiTi, a common shape memory alloy. Notice the differences in properties between the two crystalline phases, the Austenite or “memory” phase, and the Martensite or “deformable” phase.^a

^a "Using Shape Memory Alloys," Darel E. Hodgson, Ph.D. Shape Memory Applications, Inc., CA, 1988.

during cooling (The martensitic properties of SMAs in steady state are approximately a half to a third lower than the austenitic properties.) The elastic modulus and yield strength drop by almost an order of magnitude from the austenitic properties ONLY WHEN COOLED, eventually rising back up to the martensitic material properties when it has finished cooling. Figure 3 shows an approximate relationship between material yield strength and temperature as it cools.

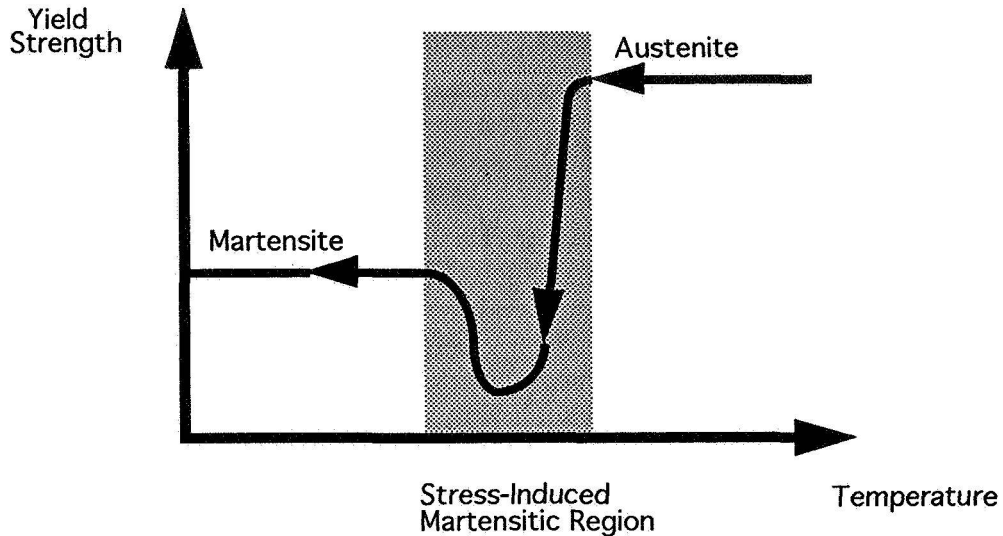

Figure 3. Material yield strength (approximate) for Nitinol vs. temperature during cooling from austenite to martensite. The stress-induced martensitic region is highlighted, showing how the material “gives” when cooled.

When the material is at its transition temperature, a bias stress can be used to induce the early formation of martensite, thus creating a soft, malleable state in the material. This property can be exploited to obtain larger material deformation without overstraining (damaging) the material. The net effect is that large deformations of the material can be obtained using relatively small forces for deformation.

This unique property of the material is exploited by simply heating the material above its transition temperature, and then applying a bias stress on it as it cools. As the material cools, it will “give” quite dramatically, thus allowing approximately twice as much material deformation than possible when trying to deform the steady state martensitic structure.

Why Use SMAs?

Nitinol was selected for use as the driver for the mechanism, due to its ability to accomplish a large amount of work per weight of material. By heating the material above its transition temperatures to induce its shape memory transformation, useful work was accomplished to deploy solar panels. The material was able to produce very high forces/torques under testing while the material’s inherent damping properties provided very smooth motion, thus removing the necessity of incorporating dampers in the system.

System Description

Overview

The Nitinol deployment mechanism uses a backbone of accordion folded members to both deploy and stiffen the satellite solar array. The backbone members rotate orthogonal to the solar array, deploying the panels and locking them flat as the backbone straightens. Figure 4 shows a picture of the deployment prototype, showing the array of four solar panels and the three member backbone.

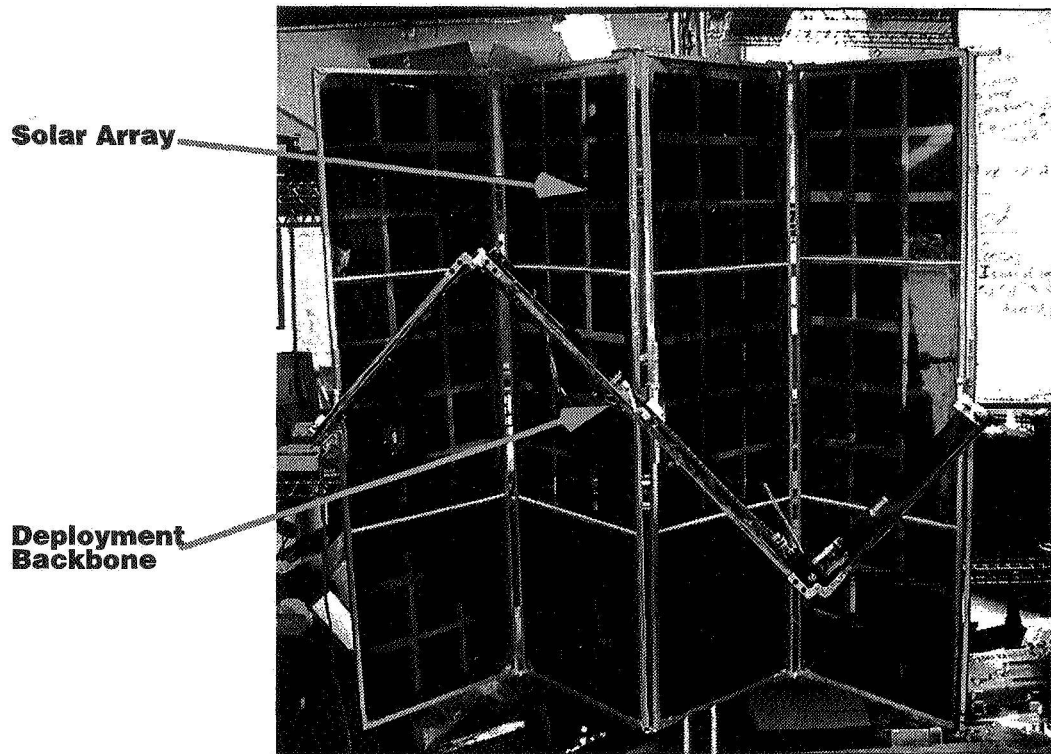

Figure 4. The Nitinol Deployment Mechanism prototype halfway through deployment. The unfolding of the backbone pulls apart and deploys the solar array.

Two Nitinol torsion bars (only one is needed to deploy, as the actuators are redundant) are mounted to the backbone and transmit torque through a right-angle drive system, applying torque to unfold the backbone and deploy the array. A flexible, electrical heating system is used to actuate the torsion bars while a simple, semi-lenticular lockup system is employed, utilizing sections of a tape measure to keep the backbone locked straight.

Deployment Backbone

The deployment backbone is the cornerstone of the Nitinol deployment mechanism. It serves dual functions in that it is used to deploy the solar array, and then stiffen it once it is deployed. Figure 5 shows a schematic diagram of how the backbone unfolds and pulls apart the solar panels to deploy the array. The backbone is mounted orthogonal

to the solar array, thus providing outstanding stiffness when deployed. The backbone is also used as the support structure for all of the other components in the mechanism.

The deployment backbone is constructed of three fiber-reinforced composite laminate members. For the sake of this prototype, poplar wood was the chosen material due to its workability, extreme light weight and high stiffness. In a final space application, graphite epoxy composites could be used.

The three backbone members are 1.3 cm (0.5") thick and 14 cm (5.5") wide. The center member is 76 cm (30") long, while the other two members are 40 cm (16") in length. The width and thickness of the backbone were determined by the stiffness requirements of the array.

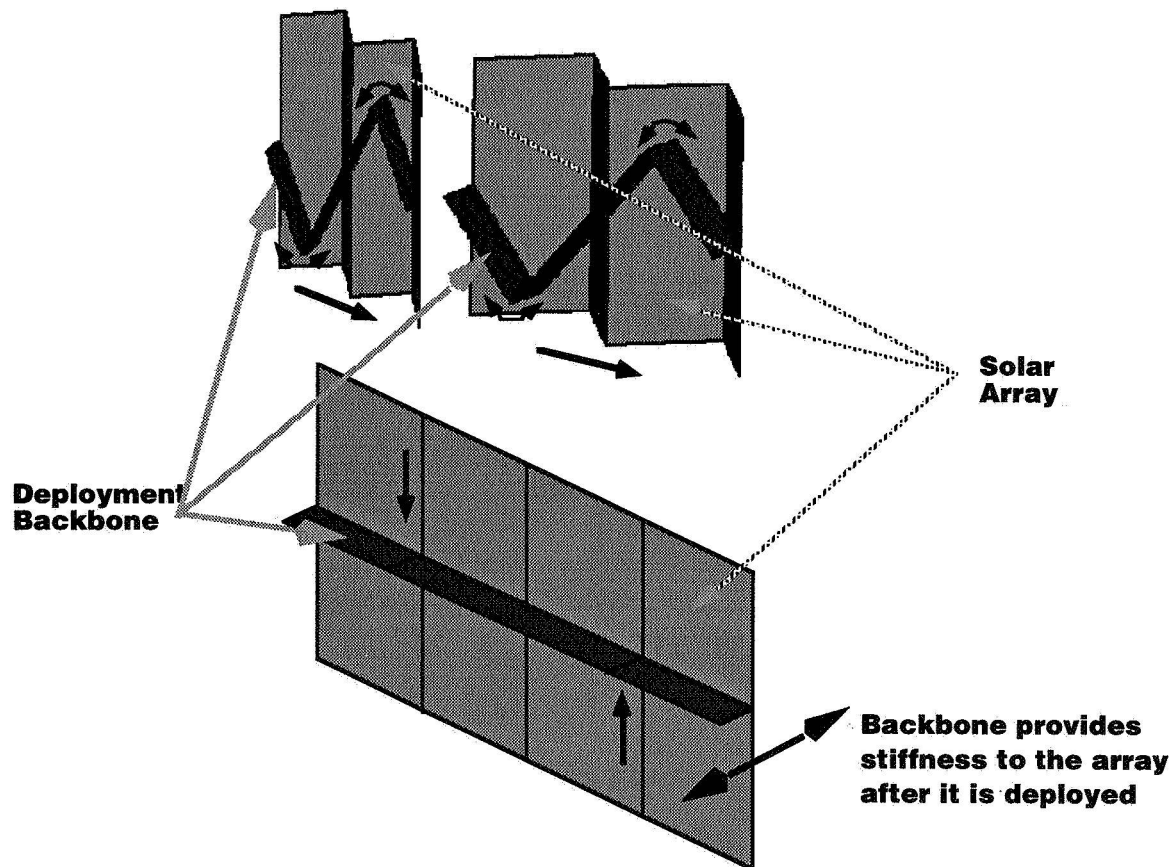

Figure 5. The deployment backbone deploys the solar array by pulling apart the solar panels as it straightens or unfolds. Notice how the backbone's orthogonal orientation stiffens the array after deployment.

The backbone members are connected together by simple, discrete, single pivot hinges. These hinges were designed to allow for the 2.5 cm (1") gap required when fully folded (stowed). The hinges also prevent the backbone from over rotating during deployment, by constraining the backbone to a maximum 180° of rotation in the fully flat (and open) position. When the backbone is folded and stowed, a 2.5 cm (1") gap is required between the members to allow for mechanism component clearance. Once

the backbone is unfolded, it must not rotate past 180° since the backbone must be flat to be an effective stiffener. Rotation of the backbone members is limited by having them meet end to end when unfolded. Figures 6 and 7 show the hinge detail when fully stowed and unfolded.

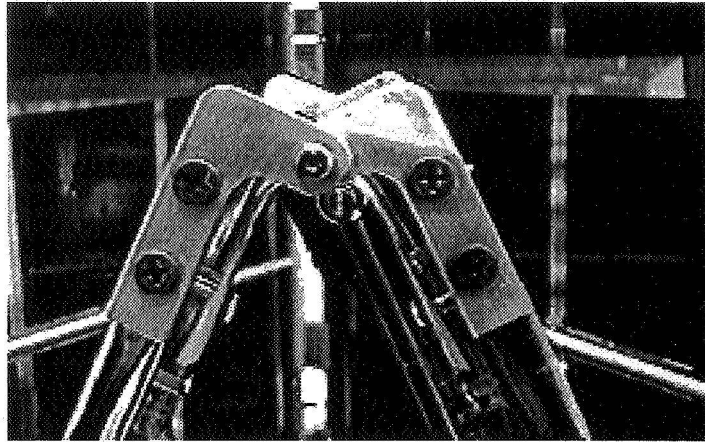

Figure 6. Backbone hinge detail when stowed. The simple hinges provide a one inch gap between the members for mechanism component clearance.

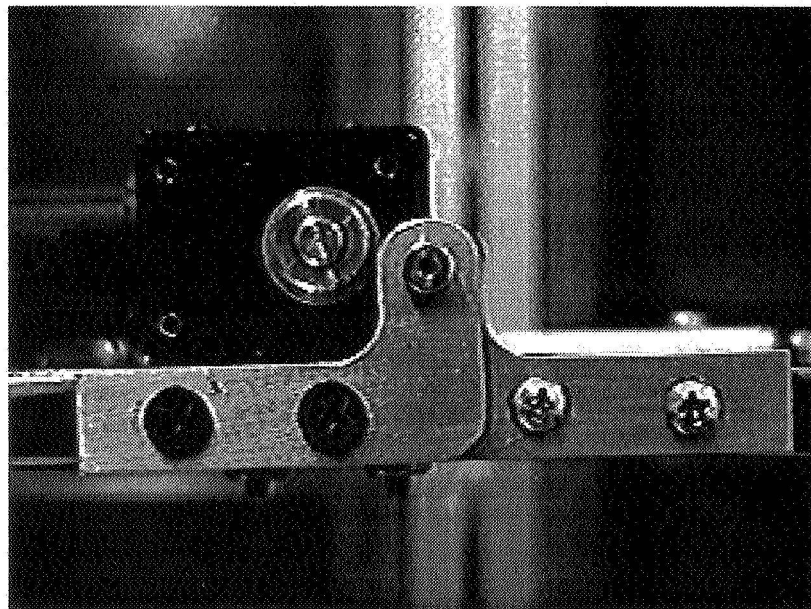

Figure 7. Hinge detail of the backbone when unfolded. The hinges cause the backbone members to meet end to end, thus assuring that the backbone will not rotate beyond flat.

Solar Array-to-Backbone Coupling

Since the solar array panels fold in one plane and the backbone members fold in yet another, a special two degree of freedom rotational joint is required to couple the two

subsystems together. The solar array-to-backbone coupling provides this function while maintaining very low friction pivot points.

Figure 8 shows a picture of the coupling system. A T-shaped bar is allowed to pivot through bronze bushings in one degree of freedom (axis of the panel rotation) while the other degree of freedom (axis of the backbone rotation) rotates within Teflon pillow blocks. By attaching the bronze bushings (via a bearing mount) to the solar array and the Teflon pillow blocks to the backbone, a rigid two degree of freedom rotational joint is formed.

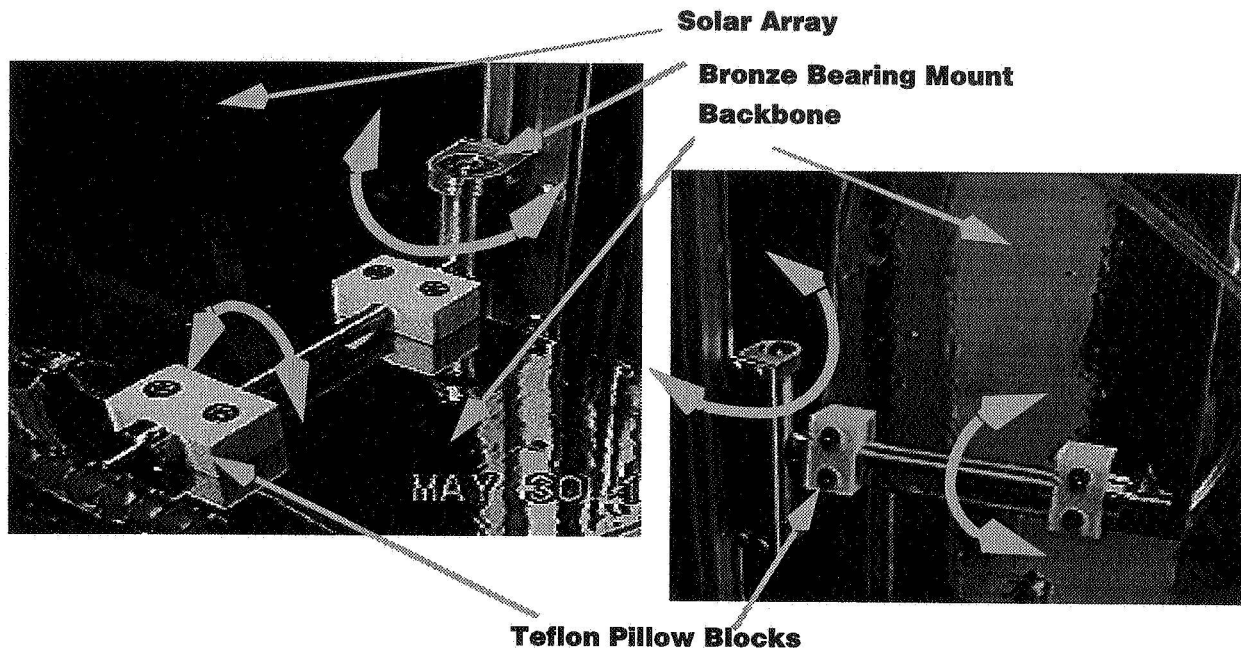

Figure 8. The Solar Array-to-Backbone Coupling allows two degree of freedom rotation, thus acting as an effective joint between the solar array and the deployment backbone.

The T-shaped bar is constructed from 1.3 cm (0.5") aluminum shaft and 6.4 mm (0.25") stainless shaft. The aluminum shaft is tapped through the middle of its length and the stainless shaft is screwed in orthogonally through the entire thickness of the aluminum.

Actuation Subsystem

The actuation subsystem applies the motive force required to unfold the backbone and thus deploy the array. This subsystem integrates a Nitinol torsion bar, a flexible heater system, a right angle drive, and a push bar. Figure 9 shows an overview of the actuation subsystem.

The actuation subsystem utilizes the untwisting of a Nitinol torsion bar to apply the torque necessary to unfold the backbone. The torque from the Nitinol driver is transmitted through the right angle drive, thus rotating the push bar against an adjacent backbone member.

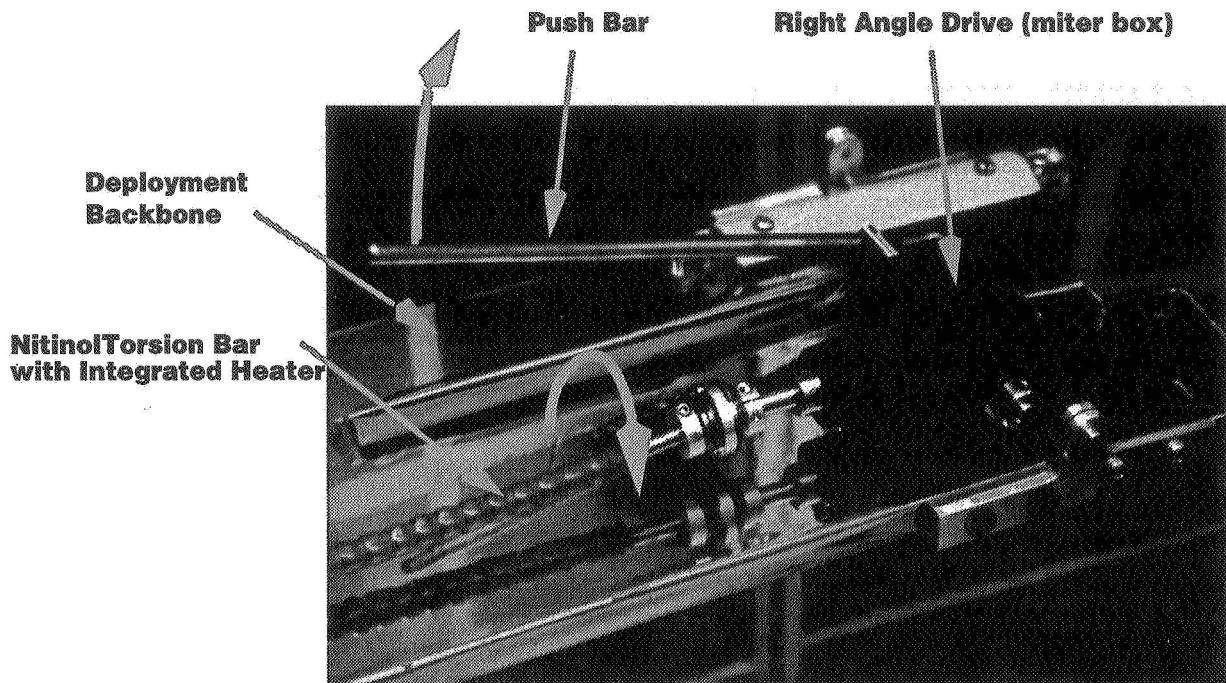

Figure 9. The actuation subsystem. A Nitinol torsion bar untwists when heated, thus applying torque through the right angle drive and push bar to unfold the backbone and therefore deploy the solar array.

SMA Torsion Bar Actuators

Two 0.48 cm (3/16") diameter, 38 cm (15") long Nitinol rods are used as torsion bars to apply the torque required to unfold the backbone and thus deploy the array. Each torsion bar actuator is constrained (clamped) on one end, while the other end is coupled to a right angle drive via a flexible shaft coupling. This allows the untwisting of the Nitinol actuator to apply a useful torque to the right angle drive. Figure 10 shows a picture of the Nitinol torsion bar mounted in the actuation system.

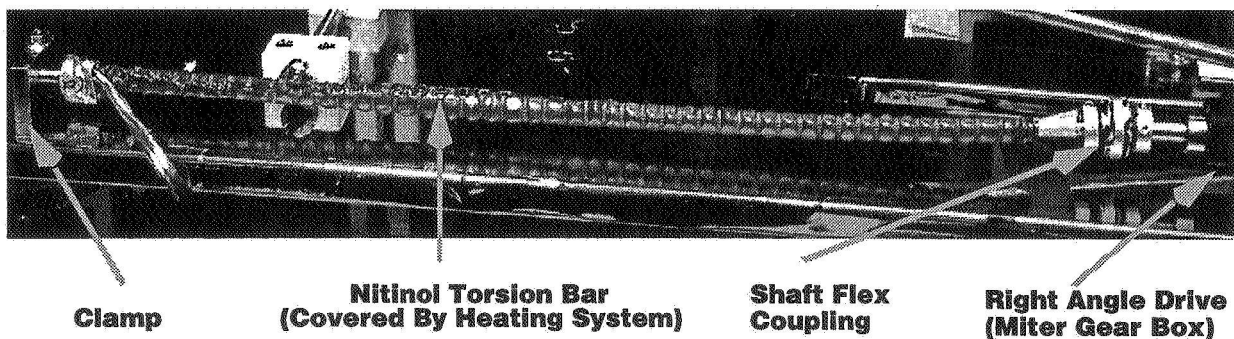

Figure 10. Nitinol torsion bar used to apply torque to deploy the array. The torsion bar is clamped on the left end and coupled to the right angle drive through a flexible shaft coupling on the right.

The Nitinol torsion bars are implemented using one-way memory, thus implying a very simple training process for the material (see section on Nitinol Torsion Bar Training). Due to the high actuation torques and large rotations required by the deployment system, the stress-induced martensitic transformation of the material is exploited. This means that the torsion bars are first heated above their transition temperature and then slightly stressed during the cooling of the material back to its martensitic state when set for deployment. This bias stress, applied as a torque of approximately 2 N•m (18 in-lb), allows the material to be deformed well beyond 270° of rotation. Since the actuator has no force at the end of its travel, it is preset with 90° of rotation to assure full deployment of the array. At start-up, the actuation torque of the torsion bars has been measured to be greater than 11.3 N•m (100 in-lb)!

The transition temperature of the actuators is set at 79°C (175°F), as requested by Lockheed for Nitinol actuators used in space applications. Heating of the material higher than this temperature is required to obtain full recovery of the material strain.

Flexible Heating Systems

Integrated, flexible, electrical heater systems are used to heat the Nitinol torsion bars above their 79°C (175°F) transition temperature. These heaters are constructed by impregnating resistive heating elements into a silicone RTV matrix and bonding them to the surface of the actuators. The heaters keep the material heated until the array has fully deployed and locked up. Since the Nitinol actuators deform during deployment, the heating systems must be able to flex and move with the actuator. This is to assure that intimate surface contact is maintained during heating. (essential for conduction, since convection does not occur in space)

Right Angle Drives: Miter Gear Boxes

The right angle drives are used to transmit the torque from the Nitinol torsion bars, around a 90° angle to the axis of rotation of the backbone members. These drives must be very smooth and must have very low friction to insure proper operation of the actuators.

The drives are merely 90° miter gear boxes that were purchased off the shelf from W. M. Berg, Inc. The particular units applied have no gear reduction, and were chosen by virtue of the fact that they were the smallest gear boxes capable of transmitting the high torques supplied by the SMA torsion bars.

Push Bar

The function of the push bar is merely to apply a force on the backbone to make it unfold during actuation. Due to its configuration, it is only capable of applying force to deploy the array. Even if the push bar rotated all the way back (for example, in the case of two way memory) no force could be applied to the backbone by the push bar. This is due to the fact that the push bar is not rigidly connected to the adjacent backbone member that it pushes against. It is allowed to retract from contact with the adjacent member, and actually rotate through the member that it is mounted on (a hole has been cut out of the member it is mounted on specifically for this purpose). The actuator bar is shown in the actuation subsystem overview, Figure 9.

Semi-Lenticular Lockup Mechanism

Lock-up of the backbone members is necessary to maintain the integrity and stiffness of the solar array. A semi-lenticular structure (provided by sections of an actual tape measure) is used to provide lock-up rigidity to the backbone in the prototype. Figure 11 shows a picture of the lenticular lockup mechanism as implemented in the prototype.

Sections of
a tape measure

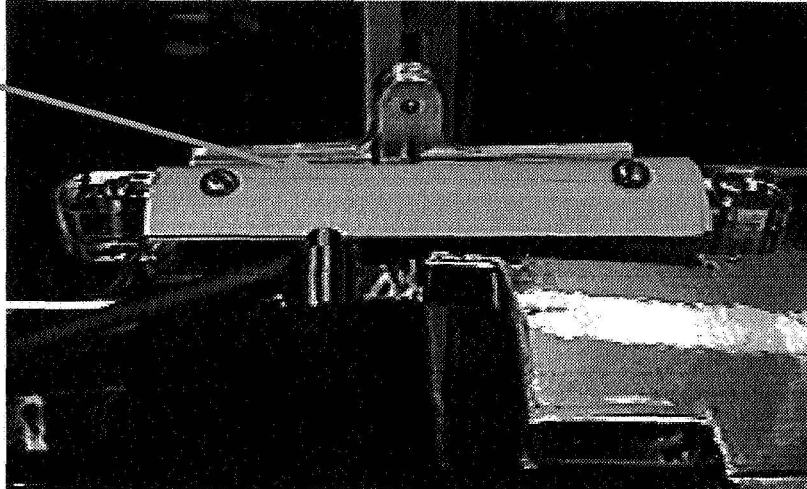

Figure 11. Sections of an actual tape measure used to lock up the deployed backbone. The curvature of the tape measure provides high stiffness when straight, but provides little resistance when folded.

A lenticular structure (named after the lentil) is a structure with a slight curvature along its length. This curved cross section creates high stiffness due to the increased section properties produced by the curvature. However, when a lenticular structure is bent, it loses its section and provides little resistance to bending. This unique property of tape measures was exploited to provide a simple, passive lockup means for the deployment mechanism.

Nitinol Torsion Bar Training

The behavior of the Nitinol actuators was predetermined by the process used to “train” them. In this particular application, the rods were trained to have one-way memory. The training process for the torsion bars was extremely simple. The 0.48-cm (3/16”)-diameter drawn, Nitinol stock was cut down to two 38 cm (15”) lengths and then placed into a fixture that constrained them in a straight position. The rods were then heated to a temperature of approximately 815°C (1500°F) for ten minutes. The heating of the rods annealed the material, thus releasing all residual stresses. The net effect of the annealing process was to set the trained or remembered shape to the straight configuration.

After training, the material can be twisted and deformed when in the martensitic (low temperature) state. When heated above 79°C (175°F), the rod returns to its straight shape (assuming that it was stressed less than 8%). If stress induced martensite is used, then material can be deformed a great deal more without overstraining the material.

Some two way memory was trained in the material, although somewhat by accident. Two way memory is trained into the material by intentionally OVERSTRAINING the material over a repeated set of load cycles.

Deployment System Stiffness Analysis

The solar array needs to have its first bending normal mode at a frequency greater than 0.1 Hz to assure that it does not interfere with the attitude control system of the satellite. The following calculations are based on the prototype as designed, extrapolated to a 6 m (20') full-sized array.

The extended solar array wing was modeled as a beam, with the moment of inertia calculated from the backbone and mass calculated from the entire system. The following equation was used to calculate the natural frequency of the system.:

$$\omega_n = \sqrt{\frac{3EI}{(0.23m)l^3}} \tag{1}$$

Where E≈17 GPa (2500 ksi), I=113 cm³ (6.9 in³), and m=24 kg (52 lb) for the solar array.

The natural frequency, ω_n is calculated as 3.7 Hz.

Figure 12 shows the relationship between the length of the array and its 1st natural frequency. It was analytically determined that the current design could be extended up to 30 m (100 ft.) without violating the 0.1 Hz first bending requirement.

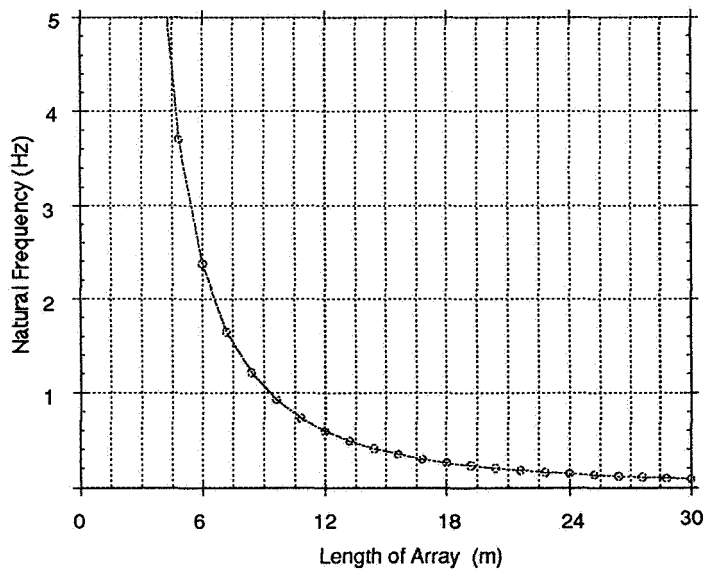

Figure 12. Natural Frequency of the Solar Array vs. the Length of the Array. Notice that the Backbone design could be scaled to a 30 m (100 ft) array without falling below the 0.1 Hz 1st bending requirement.

Concept Development

Initially the design space of possible solutions was tremendous, with concepts varying from simplistic concepts such as using Nitinol helical springs at hinge joints to "blue sky" ideas like Nitinol actuated solar sails to pull out the arrays. The Morphological Matrix in the figure below shows a cross section of the concepts developed for specific requirements.











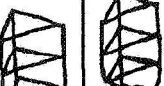

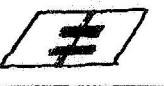
| | | | | | | |
|---------------------------|---|---|--|---|---|---|
| Deploy |  |  |  |  |  | |
| |  |  |  |  | | |
| Lockup/ Rigidity |  |  |  |  | Latching cam snap fit | Locking hinge: ratcheting over center |
| Heating |  |  |  | | | |
| Panel/Panel Connection | piano hinge | flexure bearing | discreet hinge | strings/ cables | SMR hinge | |
| Cell Support | Frame | Rigid Substrate | | | | |

Figure 13: Morphological Chart was used by the design team to generate ideas for sub-systems within the design project.

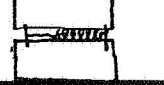
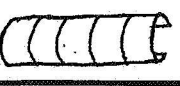
From this vast array of ideas three concepts were chosen as superior concepts because they provided both deployment and lockup/stiffness. Each of these concepts was prototyped to confirm feasibility. These three concepts were the Nitinol Semi-lenticular Spring, the Nitinol Mast, and the Nitinol Backbone Deployment System, which has already been described.

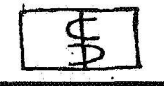
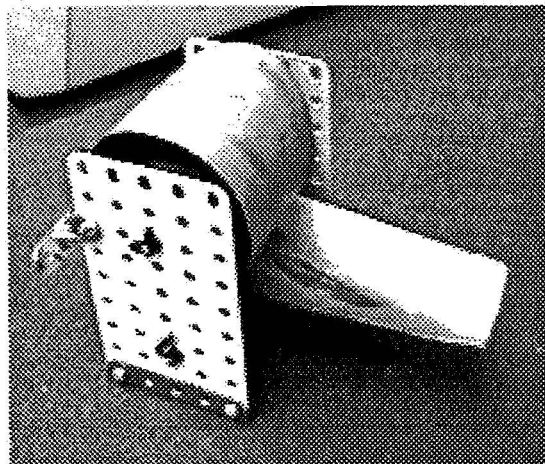

Figure 14: Nitinol Semi-lenticular prototype before heating.

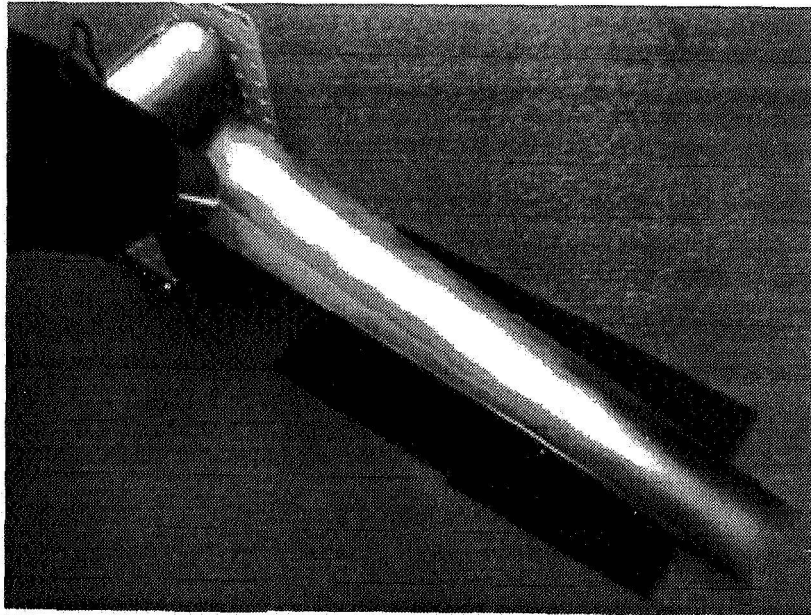

Figure 15: Nitinol Semi-lenticular prototype after the application of heat.

The semi-lenticular spring concept is a thin strip of Nitinol that is trained into a semi-circular cross section. The element is flattened and rolled onto a drum in the stored position, and it can be extended by heating the Nitinol strip to return it to the trained, curved shape. As the strip tries to regain its curvature, it pushes on itself, extending very much like a tape measure does. The semi-lenticular structure is also called a STEM (Storable Tubular Extendible Member) element in the aerospace industry.

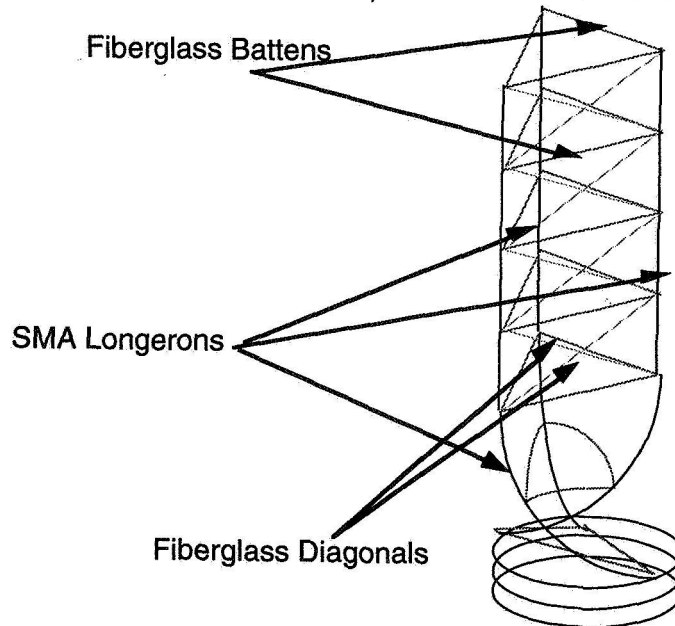

Figure 16: Nitinol Mast.

The motion of the Nitinol mast is similar to the current masts used by Lockheed made by Astro Aerospace or AEC-Able Engineering. Instead of being driven by a motor, the vertical members are replaced by Nitinol to provide recovery forces.

From these promising concepts, the Nitinol Backbone was chosen as the concept for further development. Although all could be applied effectively to solar array deployment, the Backbone was deemed to be more unique and exploited the properties of Nitinol better than the other concepts. The other concepts were also problematic due to the fact that they rely on the Nitinol to provide lockup stiffness. Nitinol exhibits a severe dip in stiffness as it cools from the austenitic to the martensitic state, thus leaving these concepts unsuitable for the combination of deployment and lockup.

Prototype Performance Results

The Nitinol Backbone deployment met and exceeded all the requirements set by the project constraints. The most poignant results are the comparisons between the Nitinol Backbone and the current state-of-the-art, the Astromast from Astro Aerospace. The table below makes direct comparisons for major performance criteria.

Table 2: Comparison of key performance characteristics between the Astromast and the Nitinol Backbone mechanism. Weight, volume, and part count are for a 6 m (20 ft) long solar array.

| | Astromast | Nitinol Backbone |
|-----------------|---|---|
| Mass | 91 kg (200 lb) | 5.4 kg (12 lb) |
| Stow Volume | 0.041 m ³ (2,500 in ³) | 0.023 m ³ (1,400 in ³) |
| Deployment Time | ≈3 minutes | ≈2-3 minutes |
| Power Required | 100 Watts | 100 Watts |
| Part Count | many(intricate parts to build mast) | 120 total, 15 distinct |

The table clearly indicates the advantages of using Nitinol over current technologies. It also achieves the required stiffness with a natural frequency of 3.7 Hz at 6 m and above 0.1 Hz at 30 m. The kinematic constraints create a natural redundancy in the actuation. If one actuator moves, the entire array will deploy. Should one of the many actuators fail, the remaining actuators are sufficient to deploy the array, increasing the reliability of the design. The deployment can be easily controlled for smooth motion by varying the heating rate of the torsion bars. As a result, no additional dampers are necessary. This further reduces the cost of the system.

Conclusion

Using a 207 g (1.5 oz) piece of Nitinol, it is possible to deploy a 1.5 m (5 ft) wing with actuation torques up to 11.3 N•m (100 in-lb) over 180° of travel. Such performance is only possible with Nitinol. The backbone system exploits Nitinol in many different ways, including utilizing the natural damping of Nitinol, the little known Stress Induced Martensitic transformation, and the simplicity of one way memory. In this 25 week

study, a prototype was successfully developed to apply the use of Nitinol to solar array deployment. Although still in the prototype stage, significant improvements in weight, stow volumes, complexity, efficiency, and system cost are foreseen through the use of Nitinol. The development of this prototype has not only seen the creation of a better, lighter, and cheaper deployment system when compared to the current state of the art, but also the conceptualization of many possible "spin-off" ideas using Nitinol that can be applied to other mechanisms. This work has shown the development of a superior deployment technology, providing the rationale and analysis necessary to foster further development of other mechanisms exploiting the unique properties of Nitinol.

References

1. T. R. Cawsey, "A Deployment Mechanism for the Double Roll-Out Flexible Solar Array on the Space Telescope," British Aerospace P.L.C., England.
2. C. M. Friend, "Shape-Strain Degradation in Reversible Shape-Memory Actuators," Scripta Metallurgica, Pergamon Journals, Ltd., 1987.
3. H. Funakubo, Shape Memory Alloys, Gordon and Breach Science Publishers, Tokyo, 1984.
4. Handbook of Satellite Array Design, JPL, CA
5. R. Haviland, C. M. House, Handbook of Satellites and Space Vehicles, D. Van Nostrand Co., Inc., Princeton, New Jersey, 1965.
6. D. Hodgson, "Shape Memory Alloys," Santa Clara, 1992.
7. D. Hodgson, "Using Shape Memory Alloys," Shape Memory Applications, Inc., CA, 1988.
8. K. Honer, A. Santoso, "Mass Positioning System," Professor Larry Leifer, instructor, for Lockheed, June 1991.
9. C. Liu, H. Kunsmann, K. Osuka, M. Wuttig, Shape-Memory Materials and Phenomena-Fundamental Aspects and Applications, Materials Research Society, Pennsylvania, 1992.
10. D. Packard, M. Benton, "The Galileo Spacecraft Magnetometer Boom," Jet Propulsion Laboratory, Pasadena, CA.
11. R. Warden, "Folding, Articulated, Square Truss," AEC-Able Engineering Co., Goleta, CA.
12. R. Warden, P. A. Jones, "Carousel Deployment Mechanism for Coilable Lattice Truss," AEC-Able Engineering Company, Inc., Goleta, CA.