



US005426512A

United States Patent [19] Watson

[11] Patent Number: **5,426,512**
[45] Date of Patent: **Jun. 20, 1995**

- [54] **IMAGE DATA COMPRESSION HAVING MINIMUM PERCEPTUAL ERROR**
- [75] Inventor: **Andrew B. Watson, Los Gatos, Calif.**
- [73] Assignee: **The United States of America as represented by the Administrator of the National Aeronautics and Space Administration, Washington, D.C.**
- [21] Appl. No.: **186,366**
- [22] Filed: **Jan. 25, 1994**
- [51] Int. Cl.⁶ **H04N 1/41; H04N 1/415; G06K 9/36**
- [52] U.S. Cl. **358/426; 358/432; 358/433; 382/232**
- [58] Field of Search **358/426, 432, 433, 429; 382/56**

published in 1992 in Human Vision, Visual Processing, and Digital Display III Proc. SPIE 1666, paper 32.
 "An Improved Detection Model for DCT Coefficient Quantization" of H. A. Peterson et al, published in 1993 in Human Vision, Visual Processing and Digital Display VI SPIE vol. 1913, pp. 191-201.
 "DCT Quantization Matrices Visually Optimized for Individual Images" of A. B. Watson, published no earlier than Feb. 1993 in Human Vision, Visual Processing and Digital IV, Proc. 1913-14.

Primary Examiner—Edward L. Coles, Sr.
Assistant Examiner—Allan A. Esposito
Attorney, Agent, or Firm—Kenneth L. Warsh; Guy M. Miller; John G. Mannix

[56] **References Cited**

U.S. PATENT DOCUMENTS

4,386,366	5/1983	Mori	358/135
4,776,030	10/1988	Tzou	382/56
4,780,761	10/1988	Daly et al.	358/133
4,783,841	11/1988	Crayson	382/56
4,831,636	5/1989	Taniguchi et al.	375/27
4,920,426	4/1990	Hatori et al.	358/433
5,101,280	5/1992	Moronaga et al.	358/426
5,121,216	6/1992	Chen et al.	358/261.3
5,170,264	12/1992	Saito et al.	358/433

OTHER PUBLICATIONS

"Luminance-Model-Based DCT Quantization for Color Image Compression" of A. J. Ahumada et al,

[57] **ABSTRACT**

A method for performing image compression that eliminates redundant and invisible image components. The image compression uses a Discrete Cosine Transform (DCT) and each DCT coefficient yielded by the transform is quantized by an entry in a quantization matrix which determines the perceived image quality and the bit rate of the image being compressed. The present invention adapts or customizes the quantization matrix to the image being compressed. The quantization matrix comprises visual masking by luminance and contrast techniques and by an error pooling technique all resulting in a minimum perceptual error for any given bit rate, or minimum bit rate for a given perceptual error.

10 Claims, 6 Drawing Sheets

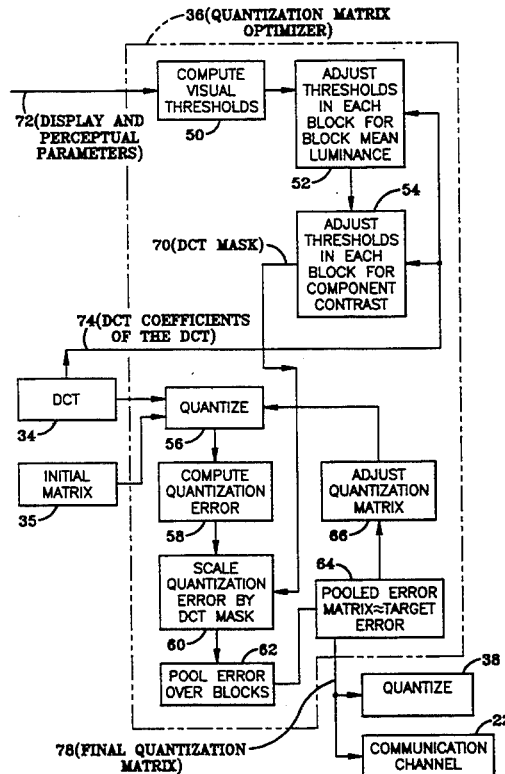

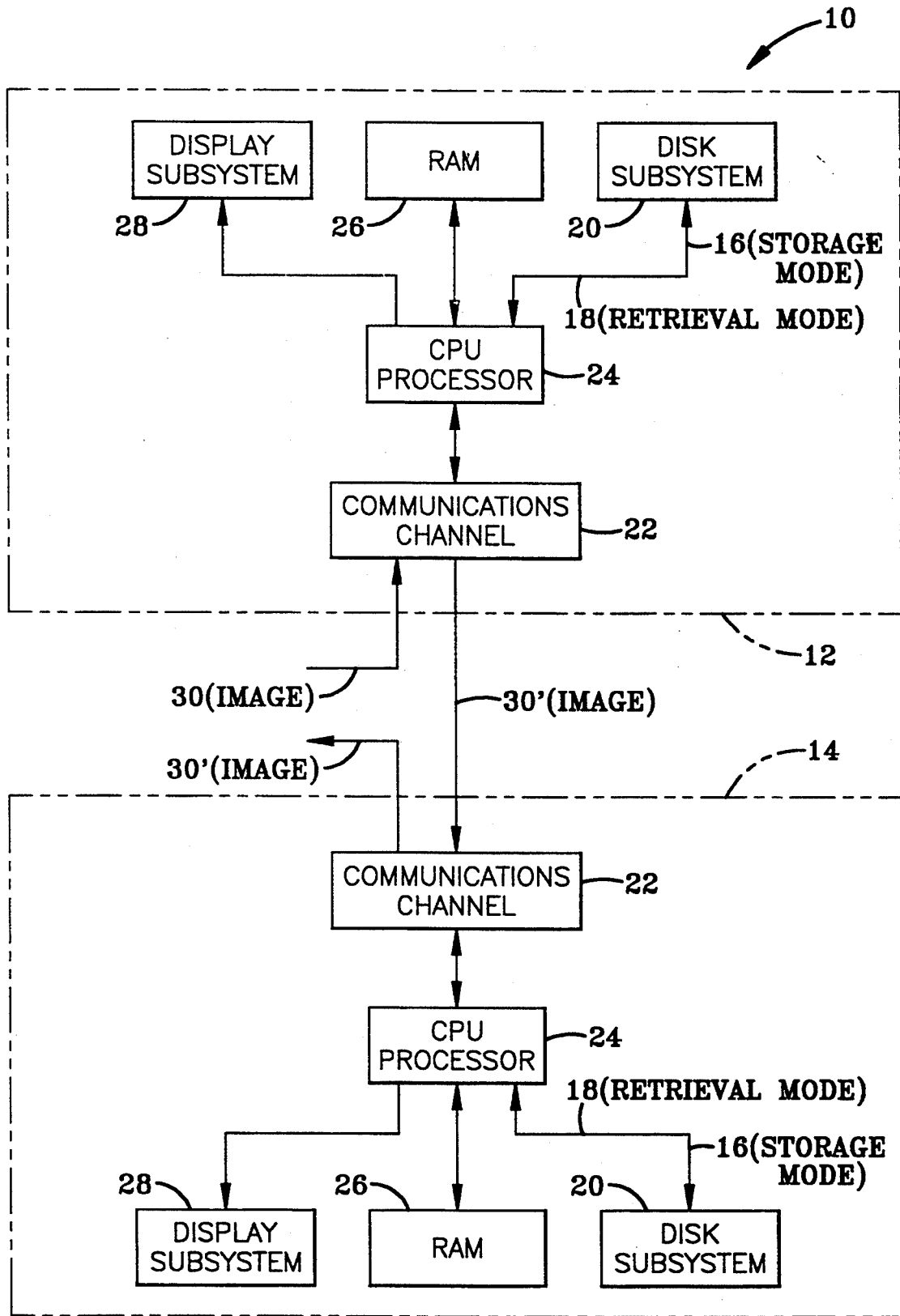
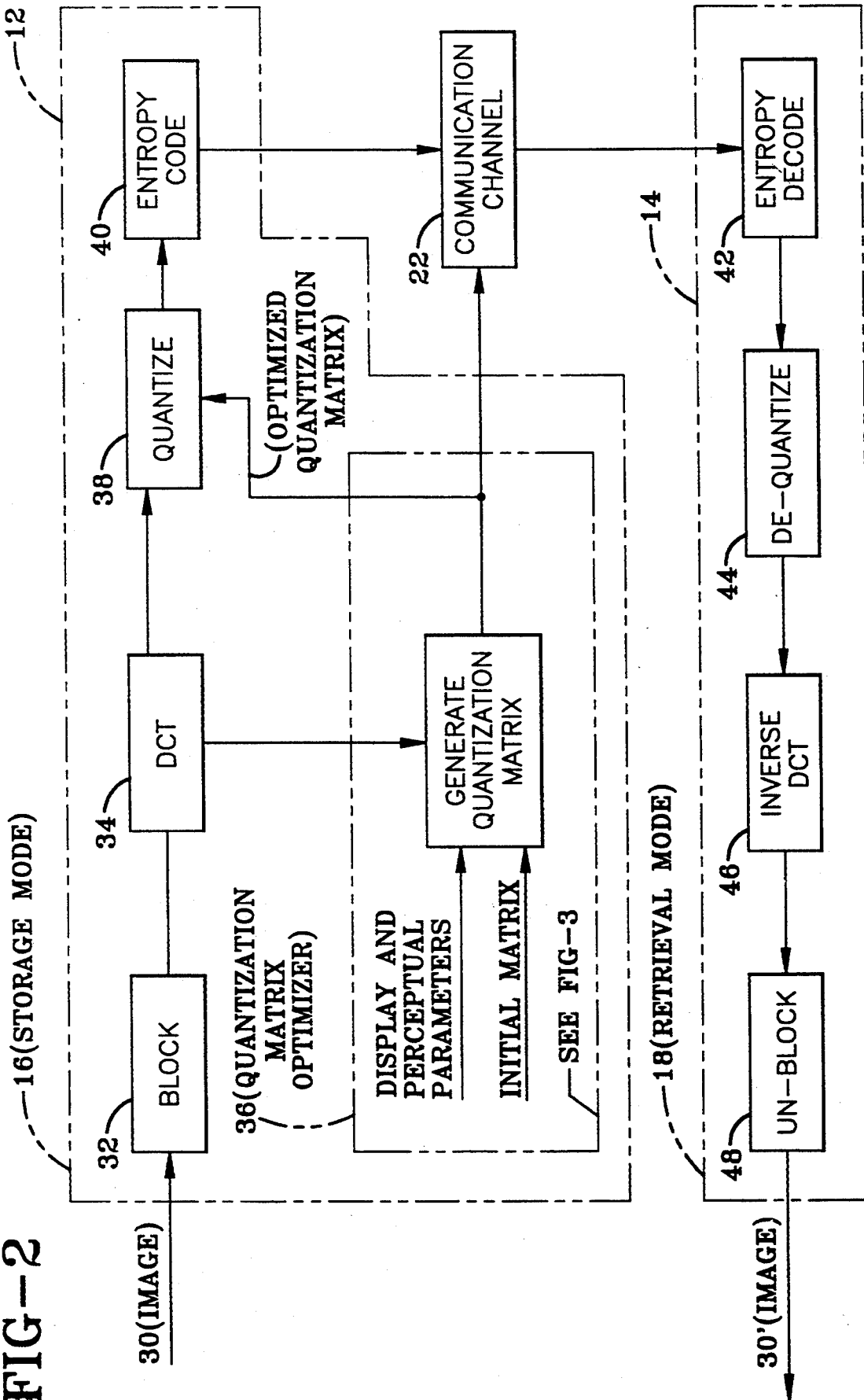

FIG-1

FIG-2



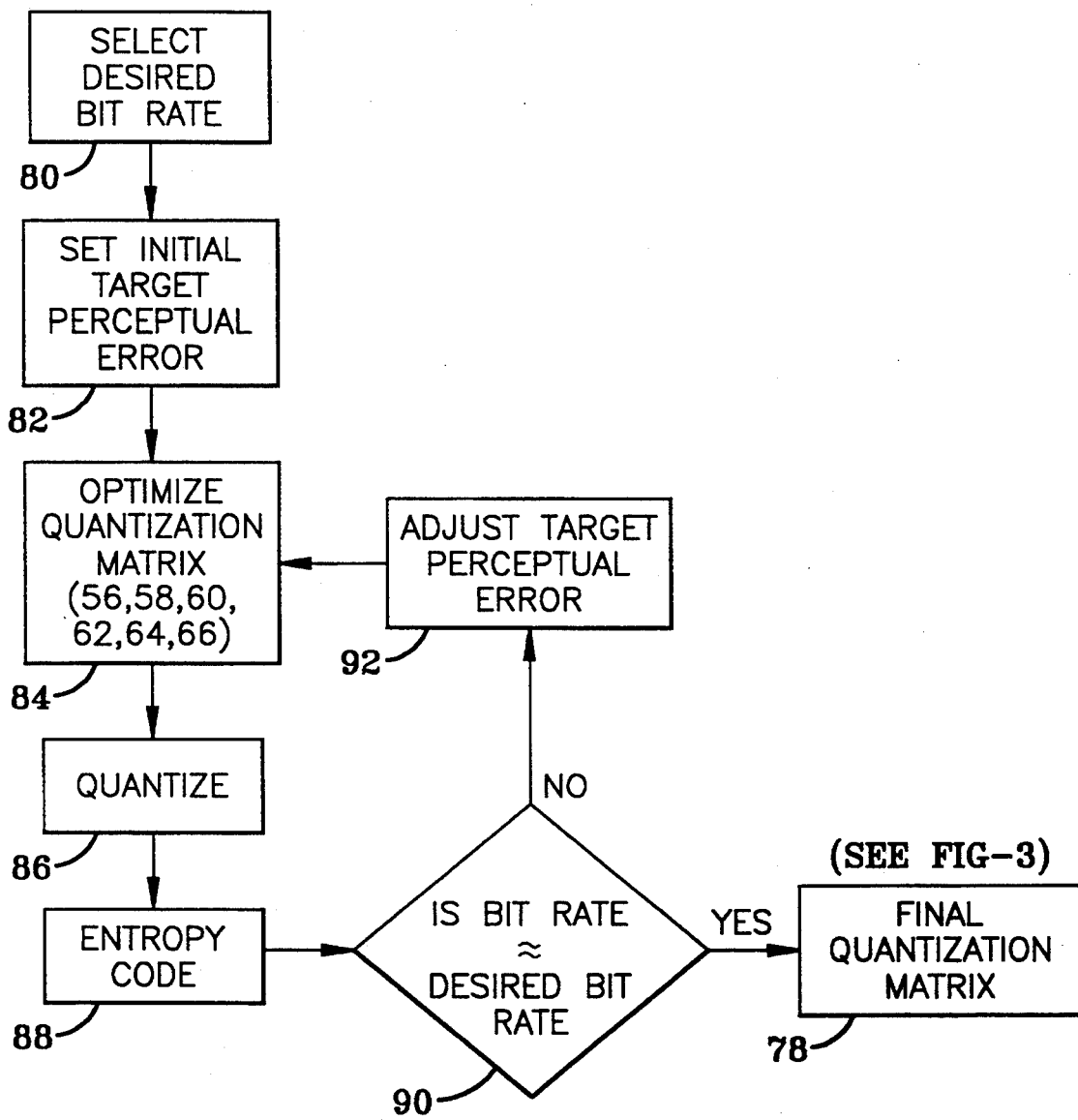

FIG-4

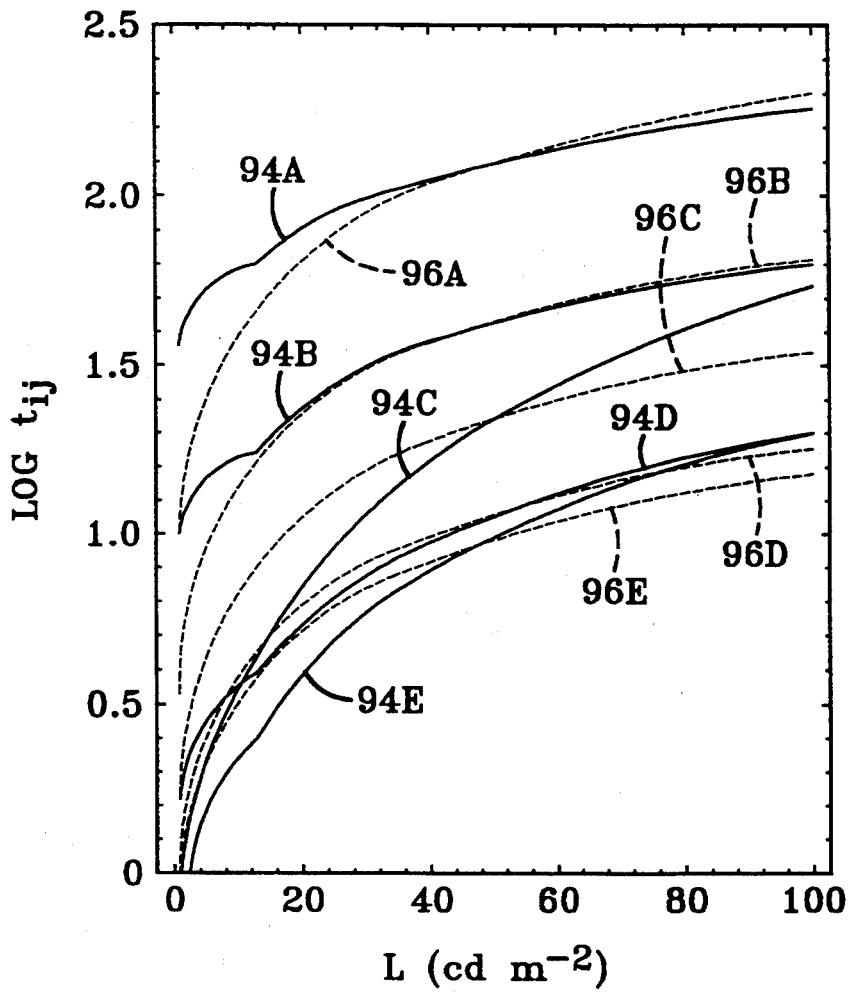

FIG-5

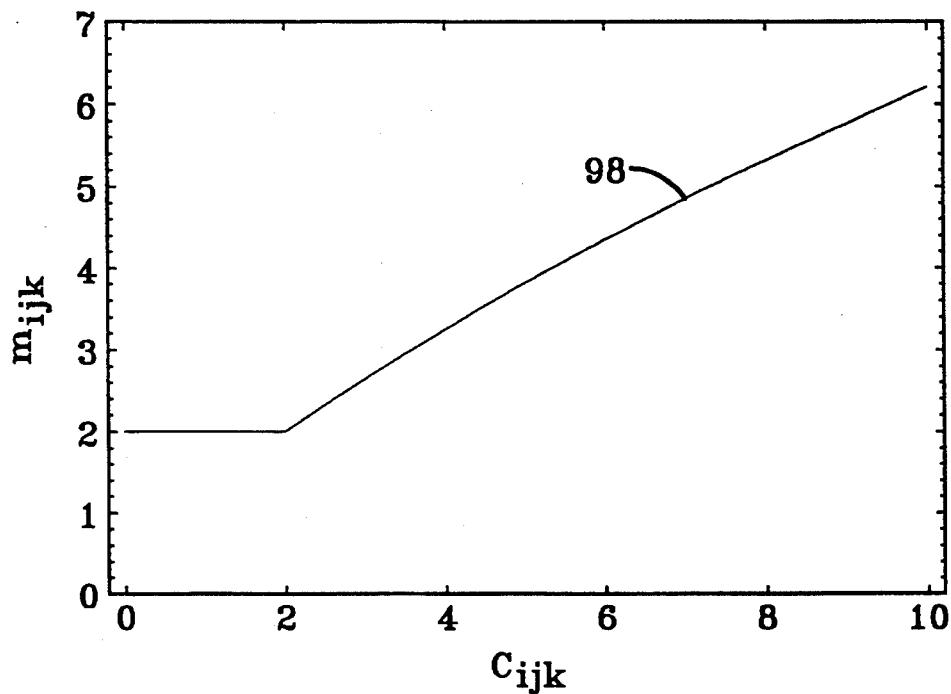

FIG-6

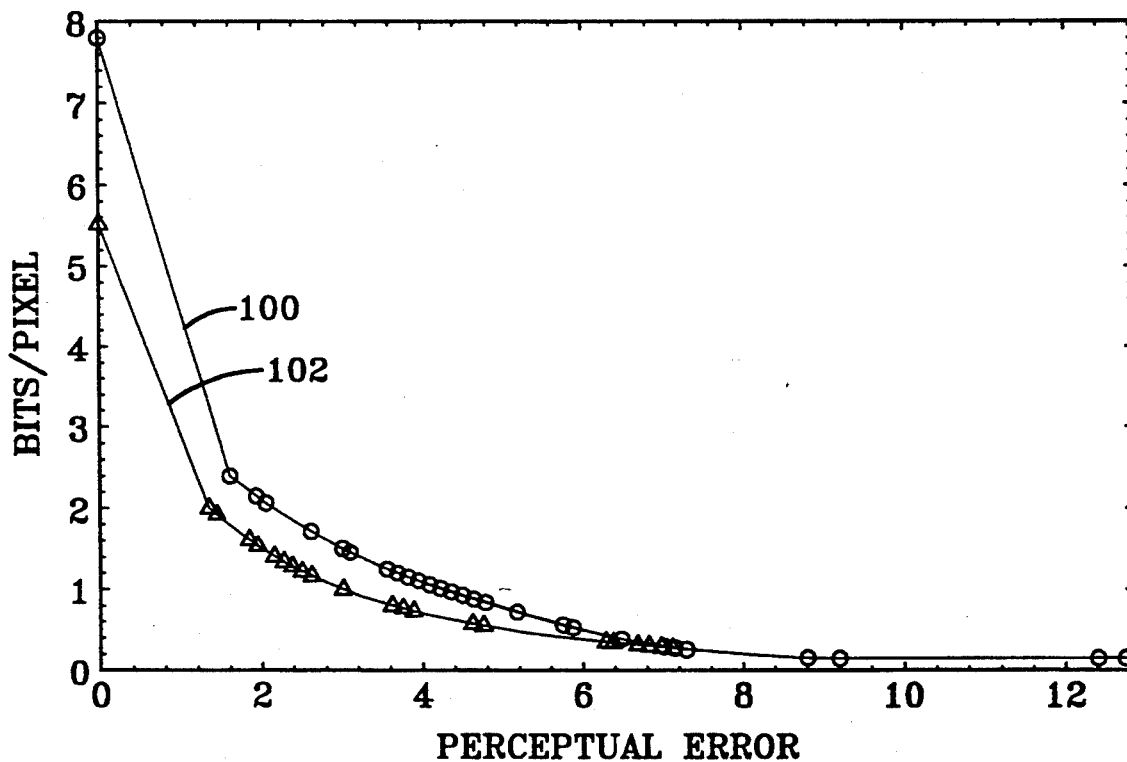

FIG-7

IMAGE DATA COMPRESSION HAVING MINIMUM PERCEPTUAL ERROR

ORIGIN OF THE DISCLOSURE

The invention described herein was made by an employee of the National Aeronautics and Space Administration and it may be manufactured and used by and for the United States Government for governmental purposes without the payment of royalties thereon or there-
fore.

BACKGROUND OF THE INVENTION

A. Technical Field of Field of the Invention:

The present invention relates to an apparatus and method for coding images, and more particularly, to an apparatus and method for compressing images to a reduced number of bits by employing a Discrete Cosine Transform (DCT) in combination with visual masking including luminance and contrast techniques as well as error pooling techniques all to yield a quantization matrix optimizer that provides an image having a minimum perceptual error for a given bit rate, or a minimum bit rate for a given perceptual error.

B. Description of the Prior Art:

Considerable research has been conducted in the field of data compression, especially the compression of digital information of digital images. Digital images comprise a rapidly growing segment of the digital information stored and communicated by science, commerce, industry and government. Digital images transmission has gained significant importance in highly advanced television systems, such as high definition television using digital information. Because a relatively large number of digital bits are required to represent digital images, a difficult burden is placed on the infrastructure of the computer communication networks involved with the creation, transmission and re-creation of digital images. For this reason, there is a need to compress digital images to a smaller number of bits, by reducing redundancy and invisible image components of the images themselves.

A system that performs image compression is disclosed in U.S. Pat. No. 5,121,216 of C.E. Chen et al, issued Jun. 9, 1992, and herein incorporated by reference. The '216 patent discloses a transform coding algorithm for a still image, wherein the image is divided into small blocks of pixels. For example, each block of pixels may be either an 8×8 or 16×16 block. Each block of pixels then undergoes a two dimensional transform to produce a two dimensional array of transform coefficients. For still image coding applications, a Discrete Cosine Transform (DCT) is utilized to provide the orthogonal transform.

In addition to the '216 patent, the Discrete Cosine Transform is also employed in a number of current and future international standards, concerned with digital image compression, commonly referred to as JPEG and MPEG, which are acronyms for Joint Photographic Experts Group and Movie Pictures Experts Group, respectively. After a block of pixels of the '216 patent undergoes a Discrete Cosine Transform (DCT), the resulting transform coefficients are subject to compression by thresholding and quantization operations. Thresholding involves setting all coefficients whose magnitude is smaller than a threshold value equal to zero,

whereas quantization involves scaling a coefficient by step size and rounding off to the nearest integer.

Commonly, the quantization of each DCT coefficient is determined by an entry in a quantization matrix. It is this matrix that is primarily responsible for the perceived image quality and the bit rate of the transmission of the image. The perceived image quality is important because the human visual system can tolerate a certain amount of degradation of an image without being alerted to a noticeable error. Therefore, certain images can be transmitted at a low bit rate, whereas other images cannot tolerate any degradation and should be transmitted at a higher bit rate in order to preserve their informational content.

The '216 patent discloses a method for the compression of image information based on human visual sensitivity to quantization errors. In the method of '216 patent, there is a quantization characteristic associated with block to block components of an image. This quantization characteristic is based on a busyness measurement of the image. The method of '216 patent does not compute a complete quantization matrix, but rather only a single scaler quantizer.

Two other methods are available for computing DCT quantization matrices based on human sensitivity. One is based on a mathematical formula for human contrast sensitivity function, scaled for viewing distance and display resolution, and is disclosed in U.S. Pat. No. 4,780,716 of S.J. Daly et al. The second is based on a formula for the visibility of individual DCT basic functions, as a function of viewing distance, display resolution, and display luminance. The second formula is disclosed in both a first article entitled "Luminance-Model-Based DCT Quantization For Color Image Compression" of A.J. Ahumada et al. published in 1992 in the *Human Vision, Visual Processing, and Digital Display III* Proc. SPIE 1666, Paper 32, and a second technical article entitled "An Improved Detection Model for DCT Coefficient Quantization" of H.A. Peterson, et al., published in 1993, in *Human Vision, Visual Processing and Digital Display VI* Proc. SPIE. Vol. 1913 pages 191-201. The methods described in the '761 patent and the two technical articles do not adapt the quantization matrix to the image being compressed, and do not therefore take advantage of masking techniques for quantization errors that utilize the image itself. Each of these techniques has features and benefits described below.

First, visual thresholds increase with background luminance and this feature should be advantageously utilized. However, the formula given in the both referenced technical articles describes the threshold for DCT basic functions as a function of mean luminance. This would normally be taken as the mean luminance of the display. However, variations in local mean luminance within the image will in fact produce substantial variations in the DCT threshold quantities. These variations are referred to herein as "luminance masking" and should be fully taken into account.

Second, threshold for a visual pattern is typically reduced in the presence of other patterns, particularly those of similar spatial frequency and orientation. This reduction phenomenon is usually called "contrast masking." This means that a threshold error in a particular DCT coefficient in a particular block of the image will be a function of the value of that coefficient in the original image. The knowledge of this function should be

taken advantage of in order to compress the image while not reducing the quality of the compressed image.

Third, the method disclosed in the two referenced technical articles ensures that a single error is below a predetermined threshold. However, in a typical image there are many errors of varying magnitudes that are not properly handled by a single threshold quantity. The visibility of this error ensemble selected to handle all varying magnitudes is not generally equal to the visibility of the largest error, but rather reflects a pooling of errors over both frequencies and blocks of the image. This pooling is herein term "error pooling" and is beneficial in compressing the digital information of the image while not degrading the quality of the image.

Fourth, when all errors are kept below a perceptual threshold, a certain bit rate will result, but at times it may be desired to have an even lower bit rate. The two referenced technical articles do not disclose any method that would yield a minimum perceptual error for a given bit rate, or a minimum bit rate for a given perceptual error. It is desired that such a method be provided to accommodate this need.

Finally, it is desired that all of the above prior art limitations and drawbacks be eliminated so that a digital image may be represented by a reduced number of digital bits while at the same time providing an image having a low perceptual error.

Accordingly, an object of the present invention is to provide a method to compress digital information yet provide a visually optimized image.

Another object of the present invention is to provide a method of compressing a visual image based on luminance masking, contrast masking, and error pooling techniques.

A further object of the present invention is to provide a quantization matrix that is adapted to the individual image being compressed so that the image that is reproduced has a high resolution and a low perceptual error.

A still further object of the present invention is to provide a method that yields minimal perceptual error of an image for a given bit rate, or a minimum bit rate for a given perceptual error of the image.

SUMMARY OF THE INVENTION

The invention is directed to digital compression of images, comprising a plurality of blocks of pixels, that uses the DCT transform coefficients yielded from a Discrete Cosine Transform (DCT) of all the blocks as well as other display and perceptual parameters all to generate a quantization matrix which, in turn, yields a reproduced image having a low perceptual error. The invention adapts or customizes the individual quantization matrix to the image being compressed.

The present invention transforms a block of pixels from an electronic image into a digital representation of that image and comprises the steps of applying a Discrete Cosine Transform (DCT), selecting a DCT mask (m_{ijk}) for each block of pixels, and selecting a quantization matrix (q_{ij}) for quantizing DCT transformation coefficients (c_{ijk}) produced by the DCT transformation. The application of a Discrete Cosine Transform (DCT) transforms the block of pixels into a digital signal represented by the DCT coefficients (c_{ijk}). The DCT mask is based on parameters comprising DCT coefficients (c_{ijk}), and display parameters. The selection of the quantization matrix (q_{ij}) comprises the steps of: (i) selecting an initial value of q_{ij} , (ii) quantizing the DCT coefficient q_{ij} in each block k to form quantized coefficient u_{ijk} , (iii)

inverse quantizing u_{ijk} by multiplying by q_{ij} , (iv) subtracting the reconstructed coefficient $q_{ij}u_{ijk}$ from c_{ijk} to compute the quantization error e_{ijk} , (v) dividing e_{ijk} by the DCT mask m_{ijk} to obtain perceptual errors; (vi) pooling the perceptual errors of one frequency ij over all blocks k to obtain an entry in a perceptual error matrix p_{ij} , and (vii) repeating this process (i-vi) for each frequency ij , and (viii) adjusting the values of q_{ij} up or down until each entry in the perceptual error matrix P_{ij} is within a target range.

The method preferably comprises a further step of entropy coding the digital representation of the image. In addition, the invention further comprises providing a computer network for implementing the practice of the present invention.

BRIEF DESCRIPTION OF THE DRAWINGS

FIG. 1 is a block diagram of a computer network that may be used in the practice of the present invention.

FIG. 2 schematically illustrates some of the steps involved with the method of the present invention.

FIG. 3 schematically illustrates the steps involved, in one embodiment, with the formation of the quantization matrix optimizer of the present invention.

FIG. 4 schematically illustrates the steps involved, in another embodiment, with the formation of the quantization matrix optimizer of the present invention.

FIG. 5 illustrates a series of plots showing the variations of the luminance patterns of a digital image.

FIG. 6 is a plot of the contrast masking function involved in the practice of the present invention.

FIG. 7 illustrates two plots each of a different digital image and each showing the relationship between the perceptual error and the bit rate involved in image compression.

DETAILED DESCRIPTION OF THE INVENTION

Referring now to the drawings wherein like reference numerals designate like elements, there is shown in FIG. 1 a block diagram of a computer network 10 that may be used in the practice of the present invention. The network 10 is particularly suited for performing the method of the present invention related to a still image that may be stored, retrieved or transmitted. For the embodiment shown in FIG. 1, a first group of channelized equipment 12 and a second group of channelized equipment 14 are provided. Further, as will be further described, for the embodiment shown in FIG. 1, the channelized equipment 12 is used to perform the storage mode 16/retrieval mode 18 operations of the network 10 and, similarly, the channelized equipment 14 is used to perform the storage mode 16/retrieval mode 18 operations of the network 10. As will be further described, the storage mode 16 is shown as accessing each disk subsystem 20, whereas the retrieval mode 18 is shown as recovering information from each disk subsystem 20. Each of the channelized equipments 12 and 14 may be a SUN SPARC computer station whose operation is disclosed in instruction manual Sun Microsystems Part #800-5701-10. Each of the channelized equipments 12 and 14 is comprised of elements having the reference numbers given in Table 1.

TABLE 1

Reference No.	Element
20	Disk Subsystem
22	Communication Channel

TABLE 1-continued

Reference No.	Element
24	CPU Processor
26	Random Access Memory (RAM)
28	Display Subsystem

In general, and as to be more fully described, the method of the present invention, being run in the network 10, utilizes, in part, a Discrete Cosine Transform (DCT), discussed in the "Background" section, to accomplish image compression. In the storage mode 16, an original image 30, represented by a plurality of digital bits, is received from a scanner or other source at the communication channel 22 of the channelized equipment 12. The image 30 is treated as a digital file containing pixel data. The channelized equipment 12, in particular the CPU processor 24, performs a DCT transformation, computes a DCT mask and iteratively estimates a quantization matrix optimizer. The channelized equipment 12 then quantizes the digital bits comprising the image 30, and performs run-length encoding and Huffman or arithmetic coding of the quantized DCT coefficients. Run-length encoding, arithmetic coding and Huffman coding are well-known and reference may be respectively made to the discussion of reference numbers 24 and 28 of U.S. Pat. No. 5,170,264, herein incorporated by reference, for a further discussion thereof. The optimized quantization matrix is then stored in coded form along with coded coefficient data, following a JPEG or other standard. The compressed file is then stored on the disk subsystem 20 of the channelized equipment 12.

In the retrieval mode 18, the channelized equipment 12 (or 14) retrieves the compressed file from the disk subsystem 20, and decodes the quantization matrix and the DCT coefficient data. The channelized equipment 12, or the channelized equipment 14 to be described, then de-quantizes the coefficients by multiplication of the quantization matrix and performs an inverse DCT. The resulting digital file containing pixel data is available for display on the display subsystem 28 of the channelized equipment 12 or can be transmitted to the channelized equipment 14 or elsewhere by the communication channel 22. The resulting digital file is shown in FIG. 1 as 30' (IMAGE). The operation of the present invention may be further described with reference to FIG. 2.

FIG. 2 is primarily segmented to illustrate the storage mode 16 and the retrieval mode 18. FIG. 2 illustrates that the storage mode 16 is accomplished in channelized equipment, such as channelized equipment 12, and the retrieval mode is accomplished in the same or another channelized equipment, such as channelized equipment 14. The channelized equipments 12 and 14 are interfaced to each other by the communication channel 22. The image 30 being compressed by the operation of the present invention comprises a two-dimensional array of pixels, e.g., 256×256 pixels. This array of pixels is composed of contiguous blocks; e.g., 8×8 blocks, of pixels representatively shown in segment 32. The storage mode 16 is segmented into the following steps: block 32, DCT 34, initial matrix, quantization matrix optimizer 36, quantize 38, and entropy code 40. The retrieval mode 18 is segmented into the following steps: entropy decode 42, de-quantize 44, inverse DCT 46, and unblock 48. The steps shown in FIG. 2 (to be further discussed with reference to FIG. 3) are associated with the image compression of the present invention and, in

order to more clearly describe such compression, reference is first made to the quantities listed in the Table 2 having a general definition given therein.

TABLE 2

Quantities	General Definition
i, j	indexes of the DCT frequency (or basis function)
k	index of a block of the image
c_{ijk}	DCT coefficients of an image
q_{ij}	quantization matrix
v_{ijk}	quantized DCT coefficients
e_{ijk}	DCT error
t_{ij}	DCT threshold matrix (based on global mean luminance)
$apw [i, j, L, px, py \dots]$	threshold formula of Peterson et al. given in the article Human Vision, Visual Processing and Digital Display VI (previously cited)
t_{ijk}	DCT threshold matrix (based on local mean luminance c_{00k})
a_r	luminance masking exponent
w_{ij}	contrast masking exponent (Weber exponent)
m_{ijk}	DCT Mask
d_{ijk}	perceptual error in a particular frequency i, j and block k
p_{ij}	perceptual error matrix
β_s	spatial error-pooling
c_{00k}	DC coefficient in block k
L_0	mean luminance of the display
c_{00}	Average DC coefficient, corresponding to L_0 (typically 1024)
ψ	target total perceptual error value

Each block (step 32) of the pixels is subjected to the application of a Discrete Cosine Transform (DCT) (step 34) yielding related DCT coefficients. The two-dimensional Discrete Cosine Transform (DCT) is well known and may be such as described in the previously incorporated by reference U.S. Pat. No. 5,121,216. The coefficients of the DCT, herein termed c_{ijk} , obtained by the Discrete Cosine Transform (DCT) of each block of pixels comprise DC and AC components. The DC coefficient is herein termed c_{00k} (0,0) which represents the average intensity of the block. The remainder of the coefficients c_{ijk} are termed AC coefficients (0,1),(1,0) . . . (ij).

The DCT (step 34) of all blocks (step 32), along with the display and perceptual parameters (to be described) and an initial matrix, are all inputted into a quantization matrix optimizer 36, which is a process that creates an optimized quantization matrix which is used to quantize (step 38) the DCT coefficients. The optimized quantization matrix is also transferred, by the communication channel 22 of the channelized equipment 12, for its use in the retrieval mode 18 that is accomplished in the channelized equipment 14. The quantized DCT coefficients (c_{ijk}) are entropy coded (step 40) and then sent to the communication channel 22. Entropy coding is well-known in the communication art and is a technique wherein the amount of information in a message is based on \log_n , where n is the number of possible equivalent messages contained in such information.

At the receiving channelized equipment 14, an inverse process occurs to reconstruct the original block of pixels thus, the received bit stream of digital information containing quantized DCT coefficients c_{ijk} is entropy decoded (step 42) and then are de-quantized (step 44), such as by multiplying by the quantization step size q_{ij} to be described. An inverse transform, such as an inverse Discrete Cosine Transform (DCT), is then ap-

then applied to the processing segment 62. The processing segment 62 causes all the scaled errors to be pooled over all of the blocks, separately for each DCT frequency (ij). The term "error pooling" is meant to represent that the errors are combined over all of the DCT coefficients rather than having one relatively large error in one DCT coefficient dominating the other errors in the remaining DCT coefficients. The pooling is accomplished by a routine having a relationship of expression 7:

$$p_{ij} = \left(\sum_k |d_{ijk}|^{\beta_s} \right)^{1/\beta_s}$$

Where d_{ijk} is an error in a particular frequency i,j , and block k , β_s is a pooling exponent having a typical value of 4. It is allowed that the routine of expression (7) provide a matrix of exponents β_s since the pooling of errors may vary for different DCT coefficients.

The matrix p_{ij} of expression (7) is the "perceptual error matrix" and is a simple measure of the visibility of artifacts within each of the frequency bands defined by the DCT basic functions. More particularly, the perceptual error matrix is a good indication of whether or not the human eye can perceive a dilution of the image that is being compressed. The perceptual error p_{ij} matrix developed by segments 56, 58, 60 and, finally, segment 62 is applied to processing segment 64.

In processing segment 64, each element of the perceptual error matrix p_{ij} is compared to a target error parameter Ψ , which specifies a global perceptual quality of the compressed image. This global quality is somewhat like the entries in the perceptual error matrix and again is a good indication of the amount of degradation that the compressed image may suffer without being perceived by the human eye. If all quantities or errors generated by segment 62 and entered into segment 64 are within a delta of Ψ , or if the errors of segment 62 are less than the target error parameter Ψ and the corresponding quantization matrix entry is at a maximum (processing segment 56), the search is terminated and the current element of quantization matrix is outputted to comprise an element of the final quantization matrix 78. Otherwise, if the element of the perceptual error matrix is less than the target parameter Ψ , the corresponding entry (segment 56) of the quantization matrix is incremented. Conversely, if the element of the perceptual error matrix is greater than the target parameter Ψ , the corresponding entry (segment 56) of the quantization matrix is decremented. The incrementing and decrementing is accomplished by processing segment 66.

A bisection method, performed in segment 66, is typically used to determine whether to increment or decrement the initial matrix 35 entered into step 56. In the bisection method a range is established for q_{ij} between lower and upper bounds, typically 1 and 255 respectively. The perceptual error matrix p_{ij} is evaluated at the mid-point of the range. If p_{ij} is greater than the target error parameter Ψ , then the lower bound is reset to the mid-point, otherwise the upper bound is reset to the mid-point. This procedure is repeated until the mid-point no longer changes. As a practical matter, since the quantization matrix entries q_{ij} in the baseline JPEG standard are eight bit integers, the needed degree of accuracy is normally obtained in nine iterations from a starting range of 1-255 (initial entry into segment 56). The output of the program segment 66 is applied to the

quantize segment 56 and then steps 56-66 are repeated, if necessary, for the remaining elements in the initial matrix. The processing segments shown in FIG. 3 yield a compressed image with a resulting bit rate; however, if a particular bit rate is desired for the image, then the processing segments shown in FIG. 4 and given in the below Table 5 are applicable.

TABLE 5

Processing Segment	Nomenclature
80	Select desired bit rate
82	Set initial target perceptual error
84	Optimize quantization matrix (56, 58, 60, 62, 64 and 66)
86	Quantize
88	Entropy code
90	Decision box (Is the bit rate \approx desired bit rate)
92	Adjust target perceptual error

The processing segments 86-92, shown in FIG. 4 and given in Table 5, allow for the attainment of a particular bit rate and utilizes a second, higher-order optimization which if the first optimization results in a bit rate which is greater than desired, the value of the target perceptual error parameter Ψ of segment 92 is incremented. Conversely, if a bit rate results which is lower than desired, the value of the target perceptual error parameter Ψ of segment 92 is decremented.

The sequence of FIG. 4 starts with the selection (segment 80) of the desired bit rate followed by the setting (segment 82) of the initial target perceptual error. The output of segment 82, as well as the output of segment 92, is applied to segment 84 which comprises segments 56, 58, 60, 62, 64 and 66, all previously described with reference to FIG. 3 and all of which contribute to provide an optimized quantization matrix in a manner also described with reference to FIG. 3. The output of segment 84 is applied to the quantize segment 86 which operates in a similar manner as described for the quantize segment 38 of FIG. 2. The output of segment 86 is applied to the entropy code segment 88 which operates in a similar manner as described for the entropy code 40 of FIG. 2.

To accomplish the adjustment of the bit rate, the output processing segment 88 is applied to a decision segment 90 in which the actual bit rate is compared against the desired bit rate and, the result of such comparison, determines the described incrementing or decrementing of the target perceptual error parameter Ψ . After such incrementing or decrementing the processing steps 84-90 is repeated until the actual bit rate is equal to the desired bit rate, and the final quantization matrix 78 is created.

It should now be appreciated that the practice of the present invention provides for a quantization matrix 78 that yields minimum perceptual error for a given bit or a minimum bit rate for a given perceptual error. The present invention, as already discussed, provides for visual masking by luminance and contrast techniques as well as by error pooling. The luminance masking feature may be further described with reference to FIG. 5.

FIG. 5 has a Y axis given in the log function of t_{ij} of expression (1) and a X axis given in display luminance L measured in cd/m^2 . The quantity t_{ij} of the block of data shown in FIG. 5 is based on a maximum display luminance L of $100 \text{ cd}/\text{m}^2$ and a grey scale (reference scale for use in black-and-white television, consisting of sev-

eral defined levels of brightness with neutral color) resolution of eight (8) bits.

Two families of curves are shown in FIG. 5 with one being 94A, 94B, 94C, 94D and 94E (shown in solid representations), and the other being 96A, 96B, 96C, 96D and 96E (shown in phantom representations). The families 94A..94E, and 96A..96E are plots for the DCT coefficient frequencies given Table 6.

TABLE 6

Plots	Frequency
94A and 96A	7, 7
94B and 96B	0, 7
94C and 96C	0, 0
94D and 96D	0, 3
94E and 96E	0, 1

Detection threshold (t_{ij}) for a luminance pattern typically depends upon mean luminance from the local image region. More particularly, the higher the background of the image being displayed, the higher, the luminance threshold. This is usually called "light adaptation" but it is called herein "luminance masking."

FIG. 5 illustrates this effect whereby higher background luminance yields higher luminance thresholds, wherein the solid plots 94A . . . 94E indicate this interdependency. In particular, it is seen that the value of t_{ij} for each of the plots 94A . . . 94E increases with increasing values of luminance. The plots 94A . . . 94E illustrate that as much 0.5 log units in t_{ij} might be expected to occur within an image, due to variations in the mean luminance of a block. The present invention takes this variation into account, whereas known prior art techniques fail to consider this wide variation.

The effect of mean luminance upon DCT coefficients of the quantization matrix q_{ij} is complex, involving both vertical and horizontal shifts of the contrast sensitivity function. The luminance-masked threshold may be determined by equation 8:

$$t_{ijk} = apw[i,j,L_0c_{00k}/\overline{c_{00}}]$$

where c_{00k} is the DC coefficient of DCT for block k, L_0 is the mean luminance of the display, and c_{00} is the DC coefficient corresponding to L_0 (1024 for an eight (8) bit image). The solution is as complete and accurate as the underlying formula, but may be rather expensive to compute. For example, in the "Mathematica" language, using a compiled function, and running on channelized equipment 14 (SUN SPARC 2) of FIG. 1, took about 1 second per block to compute this function. A second, simpler solution is to approximate the dependence of t_{ij} upon c_{00k} with the power function of the equation (2) previously given.

In practice, the initial calculation of t_{ij} should be made assuming a selected displayed luminance L_0 . The parameter a_r has a typical value of 0.649. It should be noted, that luminance masking may be suppressed by setting a_r equal to 0. More generally, a_r controls the degree to which the masking of FIG. 4 occurs. It should be further noted that the power function given in expression 2 makes it easy to incorporate a non-unity display Gamma, by multiplying a_r by the Gamma exponent having a typical value of 2.3.

The family of plots 96A . . . 96E of FIG. 5 vary in accordance with the relationship of expression 2 and are relatively accurate for the parameters above about 10 cd/m². Except for very dark sections of an image, this range should be more than adequate for most image

compressions. The discrepancy or inaccuracy of plots 96A . . . 96E is also greatest at lowest frequency, especially at the DC term (0,0) c_{00k} . This discrepancy could be corrected by adopting a matrix of exponents, one for each frequency for the relationship given in expression (2).

It should now be appreciated that the practice of the present invention provides luminance masking (shown in FIG. 5 and performed in processing segment 52 of FIG. 3) which allows for an improved quality of the compressed image so that it may be more clearly reproduced and seen the human eye.

As previously discussed with reference to processing segment 54 of FIG. 3, the present invention also provides for contrast masking. Contrast masking refers to the reduction in the visibility of one image component by the presence of another. This masking is strongest when both components are of the same spatial frequency, orientation, and location within the digital image being compressed. Contrast masking is achieved in the present invention by expression (3) as previously described. The benefits of the contrast masking function is illustrated in FIG. 6.

FIG. 6 has a Y axis given in the quantity m_{ijk} (DCT mask) and a X axis given in the quantity c_{ijk} (DCT coefficient) and illustrates a response plot 98 of the DCT mask m_{ijk} as a function of the DCT coefficient C_{ijk} for the parameter $w_{ij}=0.7$ and $t_{ijk}=2$. Because the effect of the DC coefficient c_{00k} upon the luminance masking (see FIG. 5) has already been expressed, the plot 98 does not include an effect of the DC coefficient c_{00k} and accomplishes such by setting the value of w_{00} equal to 0. From FIG. 6 it may be seen that the DCT mask (m_{ijk}) linearly increases from c_{ijk} quantities of between about 2 to 10. This DCT mask (m_{ijk}) generated by processing segment 54 adjusts each block for component contrast and is used in processing segment 60 to scale (divide) the quantization error with both functions of the DCT mask ensuring good digital compression, while still providing an image having good visual aspects.

It should be appreciated that the practice of the invention provides contrast masking so as to provide for a high quality visual representation of compressed digital images as compared to other prior art techniques.

The overall operation of the present invention is essentially illustrated in FIG. 7. FIG. 7 has a Y axis given in bits/pixel of the digital image and a X axis given in perceptual error. FIG. 7 illustrates two plots 100 and 102 for two different images that were compressed and reconstituted in accordance with the hereinbefore described principles of the present invention. From FIG. 7 it is seen that the increasing bits/pixel rate causes a decrease in the perception error.

The previously given description described herein yields a desired quantization matrix q_{ij} with a specified perceptual error Ψ . However, if desired one may have a quantization matrix q_{ij} that uses a given bit rate h_0 with a minimum perceptual error Ψ . This can be done iteratively by noting that the bit rate is a decreasing function of the perceptual error Ψ , as shown in FIG. 7. In the practice of our present invention a second order interpolating polynomial fit to all previous estimated values of $\{h, \Psi\}$ to estimate a next candidate Ψ , terminating when $|h-h_0| < \Delta h$, where Δh is the desired accuracy in bit rate. On each iteration a complete estimation of is performed.

It should now be appreciated that the practice of the present invention provides a perceptual error that incorporates visual masking by luminance and contrast techniques, and error pooling to estimate the matrix that has a minimum perceptual error for a given bit rate, or minimal bit rate for a given perceptual error. All told the present invention provides a digital compression technique that is useful in the transmission and reproduction of images particularly those found in high definition television applications.

Further, although the invention has been described relative to a specific embodiment thereof, it is not so limited and many modifications and variations thereof now will be readily apparent for those skilled in the art in light of the above teachings.

What I claim is:

1. The method for transforming a block having an index k of pixels from an electronic image into a digital representation of said image comprising the steps of:

- (a) applying a Discrete Cosine Transform (DCT) to transform said block of pixels into digital signals represented by DCT transformation coefficients C_{ijk} ;
- (b) selecting a DCT mask (m_{ijk}) for each block of pixels based on parameters comprising said DCT transformation coefficients C_{ijk} and display and perceptual parameters;
- (c) selecting quantization matrix (g_{ij}) comprising the steps of:
 - (i) selecting an initial value of q_{ij} having a DCT coefficient C_{ijk} ;
 - (ii) quantizing each DCT coefficient c_{ijk} in each block k to form quantized coefficient U_{ijk} ;
 - (iii) de-quantizing the quantized coefficients u_{ijk} by multiplying them by q_{ij} to form $q_{ij} u_{ijk}$;
 - (iv) subtracting the de-quantized coefficient $q_{ij} u_{ijk}$ from c_{ijk} to compute a quantization error e_{ijk} ;
 - (v) dividing e_{ijk} by the DCT mask m_{ijk} to obtain perceptual errors;
 - (vi) pooling the perceptual errors of one frequency ij over all blocks k to obtain an entry in a perceptual error matrix p_{ij} ;
 - (vii) repeating steps i-vi for each frequency ij ;
 - (viii) adjusting the values q_{ij} up or down until each entry in the perceptual error matrix p_{ij} is within a target range; and
 - (ix) entropy coding said quantization matrix and the quantized DCT coefficients of said image.

2. The method of transforming an image according to claim 1 further comprising the steps:

- (a) transmitting entropy coded image to a user of said digital image;
- (b) decoding said entropy coded image;
- (c) decoding said quantization matrix to derive said DCT transformation coefficients; and
- (d) applying an inverse Discrete Cosine Transform to derive said block of pixels.

3. The method of transforming an image according to claim 2, wherein block mean luminance and component contrast are included in said display and perceptual parameters and are determined by the following expression:

$$t_{ijk} = t_{ij}(C_{00}/\overline{C_{00}})^{a_i}$$

where a_i is a luminance-masking exponent having a value of about 0.65, t_{ij} is the un-adjusted threshold of luminance, C_{00} is an average of the DC terms of the

DCT coefficients C_{ijk} of the image, and c_{ijk} is the DC coefficient of block k .

4. The method of transforming an image according to claim 2, wherein said DCT mask is determined by the following expression:

$$m_{ijk} = \text{Max} [t_{ijk}, |C_{ijk}|^{w_{ij}} t_{ijk}^{1-w_{ij}}]$$

where C_{ijk} is the DCT coefficient, t_{ijk} is a corresponding block mean luminance adjusted threshold, and w_{ij} is an exponent that lies between 0 and 1 and is about 0.7.

5. The method of transforming an image according to claim 2, wherein said pooling of perceptual errors is determined by the following expression:

$$p_{ij} = \left(\sum_k |d_{ijk}|^{\beta_s} \right)^{1/\beta_s}$$

6. The computer involved in converting a block having an index k of pixels from an electronic image into a digital representation of said image, said computer comprising:

- (a) means for applying a Discrete Cosine Transform (DCT) to transform said block of pixels into digital signals represented by DCT transformation coefficient (c_{ijk});
- (b) means for selecting a DCT mask (m_{ijk}) for each block of pixels based on parameters comprising said DCT transformation coefficients c_{ijk} and display and perceptual parameters;
- (c) means for selecting a quantization matrix (q_{ij}) comprising:
 - (i) means for selecting an initial value of q_{ij} ;
 - (ii) means for quantizing the DCT coefficient c_{ijk} in each block k to form quantized coefficient u_{ijk} ;
 - (iii) means for de-quantizing the quantized coefficients U_{ijk} by multiplying them by q_{ij} to form $q_{ij} u_{ijk}$;
 - (iv) means for subtracting the de-quantized coefficient $q_{ij} u_{ijk}$ from c_{ijk} to compute a quantization error e_{ijk} ;
 - (v) means for dividing e_{ijk} by the DCT mask m_{ijk} to obtain perceptual errors;
 - (vi) means for pooling the perceptual errors of one frequency ij over all blocks k to obtain an entry in a perceptual error matrix p_{ij} ;
 - (vii) means for adjusting the values q_{ij} up or down until each entry in the perceptual error matrix p_{ij} is within a target range; and
- (d) means for entropy coding said quantization matrix and the quantized DCT coefficients of said image.

7. The computer involved in converting an image according to claim 6 further comprising:

- (a) means for transmitting entropy coded image to a user of said digital image;
- (b) means for decoding said entropy coded image;
- (c) means for decoding said quantization matrix to derive said DCT transform coefficients; and
- (d) means for applying an inverse Discrete Cosine Transform to derive said block of pixels.

8. The computer involved in converting an image according to claim 6, wherein block mean luminance and component contrast are included in said display and perceptual parameters and are determined by the following expression embodied in the operation of said means for selecting a DCT mask:

15

$$t_{ijk} = t_{ij}(C_{ook}/C_{oo})^{a_i}$$

where a_i is a luminance-masking exponent having a value of about 0.65, t_{ij} is the un-adjusted threshold of luminance, C_{oo} is an average of the DC terms of the DCT coefficients C_{ijk} of the image, and C_{ook} is the DC coefficient of block k.

9. The computer network involved in converting an image according to claim 6, wherein said DCT mask is determined by the following expression embodied in said means for selecting a DCT mask:

$$m_{ijk} = \text{Max}[t_{ijk}, |C_{ijk}|^{W_j} t_{ijk}^{1-W_j}]$$

m_{ijk} , is the contrast-adjusted threshold, c_{ijk} is the DCT coefficient, t_{ijk} is the corresponding threshold of expres-

16

sion 2, and w_{ij} is the exponent that lies between 0 and 1 and typically has a value of 0.7.

10. The computer involved in converting an image according to claim 6, wherein said pooling of perceptual errors is determined by the following expression embodied in said means for pooling:

$$p_{ij} = \left(\sum_k |d_{ijk}|^{\beta_s} \right)^{1/\beta_s}$$

Where d_{ijk} is an error in a particular frequency i, j, and block k, β_s is a pooling exponent having a typical value of 4.

* * * * *

20

25

30

35

40

45

50

55

60

65