

TR-376-22

ENDURANCE TEST AND EVALUATION OF
ALKALINE WATER ELECTROLYSIS CELLS

INTERIM REPORT

by

A. J. Kovach, F. H. Schubert, B. J. Chang
and J. T. Larkins

January, 1985

Prepared Under

Contract NAS3-21287

by

Life Systems, Inc.
Cleveland, OH 44122

for

Lewis Research Center
National Aeronautics and
Space Administration



FOREWORD

The development work reported herein was conducted by Life Systems, Inc. in Cleveland, Ohio under Contract NAS3-21287 during the period June 1, 1981 through December 31, 1984. The program managers were Franz H. Schubert and Jim Larkins. The personnel contributing to the program and their responsibilities are outlined below.

| <u>Personnel</u> | <u>Area of Responsibility</u> |
|---------------------|--|
| Carl Baron | Software Design, Test Support |
| Ken Burke | Test Support, Unitized Core Development |
| B. J. Chang, Ph.D. | Component Development, Technology Studies |
| Steve Czernek | Mechanical System and Test Support Accessories Assembly |
| Robert Ellacott | Module and Component Assembly |
| Don Johnson | Electronic Assembly and Checkout |
| Andrew Kovach | Subsystem Design, Subsystem Testing, Module Design and Evaluation |
| Jim Larkins | Program Management |
| Dorothy Ruschak | Contract Administration |
| Franz Schubert | Program Management and Subsystem Design |
| Lowell Wolfe | Fabrications, Unitized Core Development |
| Rick Wynveen, Ph.D. | Contract Administration |

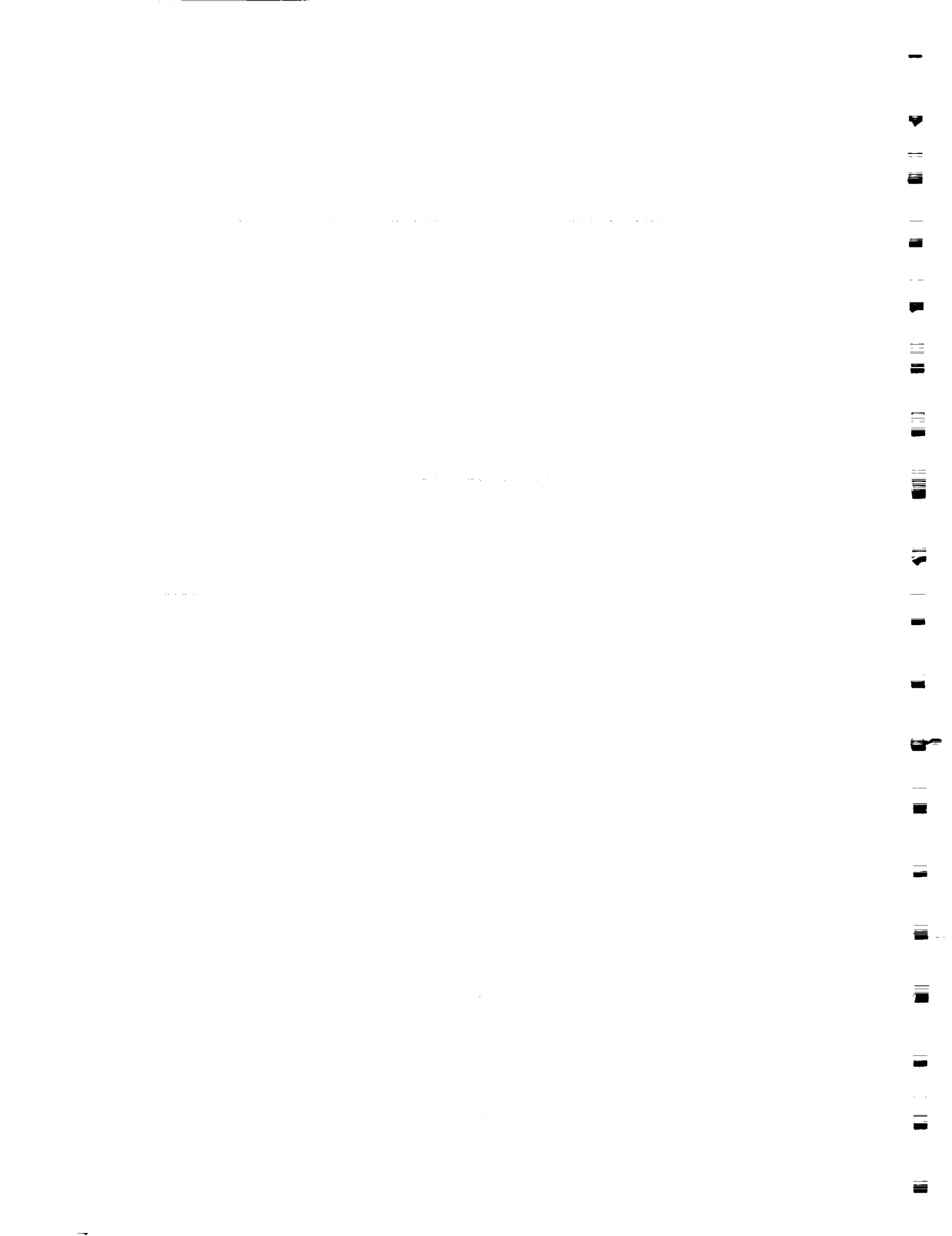

TABLE OF CONTENTS

| | <u>PAGE</u> |
|--|-------------|
| LIST OF FIGURES | iii |
| LIST OF TABLES | iv |
| LIST OF ACRONYMS | v |
| SUMMARY | 1 |
| INTRODUCTION | 2 |
| Background | 2 |
| Regenerative Fuel Cell Orbital Energy Storage Concept | 2 |
| Static Feed Water Electrolysis Concept | 4 |
| State-of-the-Art Cell Performance Base | 6 |
| Program Objectives | 6 |
| End Items | 8 |
| Program Organization | 9 |
| 1.0-FT ² WATER ELECTROLYSIS CELL AND MODULE DEVELOPMENT | 9 |
| 1.0 Ft ² Cell Frame Development | 9 |
| 1.0 Ft ² Multicell Module Development | 13 |
| O ₂ Port Isolation | 16 |
| Unitized Core Development | 16 |
| Lightweight End Plates | 20 |
| REGENERATIVE FUEL CELL ELECTROLYZER SUBSYSTEM (WS-6) DEVELOPMENT | 22 |
| Design Specifications | 22 |
| WS-6 Mechanical/Electrochemical Assembly | 36 |
| WS-6 Control/Monitor Instrumentation | 36 |
| Test Program WS-6 SNO1 | 36 |
| Checkout Testing | 36 |
| Shakedown Testing | 43 |
| Parametric Testing - Pressure | 43 |
| Parametric Testing - Temperature | 45 |
| Endurance Test | 45 |
| DEVELOPMENT OF HIGH PRESSURE WATER ELECTROLYSIS MODULE ENDURANCE TEST STAND | 45 |

continued-

Table of Contents - continued

| | <u>PAGE</u> |
|--|-------------|
| ENDURANCE TESTING - 0.1 FT ² WATER ELECTROLYSIS CELLS AND MODULES . . . | 48 |
| Single Cell Endurance Testing at Ambient Pressure | 53 |
| SWEC Endurance Test 105A | 53 |
| SWEC Endurance Test 105B | 53 |
| SWEC Endurance Test 105C | 55 |
| SWEC Endurance Test 105D | 55 |
| 0.1 ft ² High Pressure Single Cell Testing | 58 |
| Six-cell 0.1 ft ² High Pressure Module Endurance Testing | 58 |
| CONCLUSIONS | 58 |
| RECOMMENDATIONS | 62 |
| REFERENCES | 62 |

LIST OF FIGURES

| <u>FIGURE</u> | | <u>PAGE</u> |
|---------------|--|-------------|
| 1 | Regenerative Fuel Cell Orbital Energy Storage Concept | 3 |
| 2 | Cell Functional Schematic | 5 |
| 3 | Static Feed Water Electrolysis Subsystem Schematic | 7 |
| 4 | 1.0 ft ² Cell Frame | 10 |
| 5 | 1.0 ft ² Single Cell Cross Sectional View | 12 |
| 6 | Fluids and Structural Insulation Plates with Current Buss Bars for 1.0 ft ² Module | 15 |
| 7 | 0.1 ft ² Unitized Core Parts | 19 |
| 8 | Unitized Core Cell Frame and Other Cell Parts | 21 |
| 9 | Incorporation of a Typical Port Passthrough into End Plate Structure | 23 |
| 10 | Incorporation of a Typical Bolt Insert into End Plate Structure | 24 |
| 11 | Incorporation of Close-Outs into End Plate Structure | 25 |
| 12 | External View of Six-Cell 1.0 ft ² Electrolyzer Module | 26 |
| 13 | Six-Cell 1.0 ft ² Water Electrolysis Module with Lightweight Honeycomb End Plates | 27 |
| 14 | WS-6 Subsystem Mechanical Schematic with Sensors | 29 |
| 15 | WS-6 Mechanical/Electrochemical Assembly | 30 |
| 16 | WS-6 TSA Operating Data Display and Fluid Supply Simulators | 33 |
| 17 | WS-6 SFE Mass and Energy Balance | 35 |
| 18 | WS-6 Mechanical/Electrochemical Assembly with C/M I | 38 |
| 19 | WS-6 Subsystem with Test Support Accessories (TSA) and Uninterruptible Power Supply (UPS) | 39 |
| 20 | WS-6 Modes and Allowable Mode Transitions | 40 |
| 21 | Cell Performance Versus Time, WS-6 Parametric Test | 44 |
| 22 | Cell Voltage Versus Cell Temperature, WS-6 Parametric Test | 46 |
| 23 | Cell Performance Versus Time, WS-6 Endurance Test | 47 |
| 24 | Mechanical Schematic for High Pressure Test Stand | 49 |
| 25 | Front Panel View - High Pressure Test Stand | 50 |
| 26 | Full View - High Pressure Test Stand | 51 |
| 27 | Single Cell Performance Versus Time, Cell No. 105A | 54 |
| 28 | Single Cell Performance Versus Time, Cell No. 105B | 56 |
| 29 | Single Cell Performance Versus Time, Cell No. 105C | 57 |
| 30 | Single Cell Performance Versus Time, Cell No. 105D | 59 |
| 31 | Cell Performance Versus Time, Cell. No. 127, High Pressure Operation | 60 |
| 32 | Cell Performance Versus Time, Module No. 127 | 61 |

LIST OF TABLES

| <u>TABLE</u> | | <u>PAGE</u> |
|--------------|---|-------------|
| 1 | 1.0 ft ² Module Hardware Weight Summary | 14 |
| 2 | Six-Cell 1.0 ft ² Module Operating Characteristics | 17 |
| 3 | End Plate Center Deflection as a Function of Pressure | 28 |
| 4 | WS-6 Application Design Specifications | 31 |
| 5 | WS-6 Nominal Subsystem Interfaces | 34 |
| 6 | Mechanical Component Characteristic Summary: SFE WS-6 | 37 |
| 7 | WS-6 Operating Modes and Unpowered Mode Definitions | 41 |
| 8 | Static Feed Water Electrolysis Test Summary | 52 |

LIST OF ACRONYMS

| | |
|-----------|---|
| ASF | Amps per Square Foot |
| C/M I | Control and Monitor Instrumentation |
| CCA | Coolant Control Assembly |
| EMS | Engineering Model System |
| FCA | Fluids Control Assembly |
| FCS | Fuel Cell Subsystem |
| IRAD | Internal Research and Development |
| KOH | Potassium Hydroxide |
| NASA JSC | NASA Johnson Space Center |
| NASA LeRC | NASA Lewis Research Center |
| RFCS | Regenerative Fuel Cell System |
| RFCSB | Regenerative Fuel Cell System Breadboard |
| SFE | Static Feed Electrolyzer |
| SFWE | Static Feed Water Electrolysis |
| SWEC | Static Water Electrolysis Cell |
| 3-FPC | Three-Fluids Pressure Controller |
| TSA | Test Support Accessories |
| UPS | Uninterruptible Power Supply |
| WES | Water Electrolysis Subsystem |
| WS-6 | Regenerative Fuel Cell Electrolyzer Subsystem |



SUMMARY

The alkaline Regenerative Fuel Cell System (RFCS) is the most promising electrochemical Energy Storage concept for the Space Station. An alkaline RFCS-based Energy Storage System consisting of a Static Feed Water Electrolysis (SFWE) Subsystem, a Fuel Cell Subsystem (FCS) and reactant storage assemblies and controls, is characterized by low launch weight and volume and high electrical-to-electrical efficiency. The RFCS offers the capability of integration with other systems aboard the Space Station and is inherently adaptive to meeting emergency energy storage demands through the simple addition of reactant storage tanks.

The development of the alkaline SFWE subsystem of the RFCS has been advanced by evaluating the endurance capabilities of SFWE cells and modules under a variety of test conditions, including continuous testing, cyclic testing, variable current density and temperature and high pressure testing. Four SFWE cells of 0.1 ft² active electrode area are undergoing testing at both cyclic and continuous operating conditions. Total accumulated test time has reached 116,522 cell-hours with three cells approaching four years of operation. In other testing, a 0.1 ft² SFWE cell has been endurance tested at high pressure for 6,900 hr while a six-cell 0.1 ft² module has been operating at high pressure for 2,450 hr.

As the SFWE data base continues to grow, the design of the SFWE cell and module has been optimized for use in a RFCS. The RFCS demands scale-up of the existing 0.1 ft² cell design to a 1.0 ft² active electrode area cell. A single water electrolysis cell and two six-cell modules of 1.0 ft² active electrode area were designed and fabricated. The two six-cell modules incorporate the 1.0 ft² unitized core, which accounts for overall ruggedness of the module by allowing for increased tolerance to pressure differentials and reproducibility and simplicity of assembly. The 1.0 ft² modules are weight optimized by using lightweight honeycomb end plates, molded O-rings and area efficient cell frames.

A Regenerative Fuel Cell Electrolyzer Subsystem (WS-6) was developed for testing of the two six-cell 1.0 ft² modules. The WS-6 is a completely automated subsystem consisting of the SFWE module along with fluids control components specifically designed and developed for use with the SFWE subsystem. A test program for the WS-6 has been ongoing with 695 hr of parametric and endurance testing accumulated to date. One of the six-cell 1.0 ft² modules has been incorporated into NASA JSC's Regenerative Fuel Cell System Breadboard (RFCSB) where it is currently undergoing extensive testing, first at Life Systems, Inc., then at NASA JSC.

A study program was successfully completed by Life Systems, Inc. to define further the regenerative fuel cell concept and specifically define a 10 kW, alkaline electrolyte based Engineering Model System (EMS) prototype. The results of the RFCS study and the EMS design definition are presented in another publication. (1)

(1) Superscribed numbers in parenthesis are citations of references listed at the end of this report.

INTRODUCTION

The overall objective of this program is to assess the state of alkaline water electrolysis cell technology and its potential as part of a Regenerative Fuel Cell System (RFCS) of a multikilowatt orbiting powerplant. The program evaluates the endurance capabilities of alkaline electrolyte water electrolysis cells under various operating conditions, including constant condition testing, cyclic testing and high pressure testing.

The RFCS demanded the scale-up of existing cell hardware from 0.1 ft² active electrode area to 1.0 ft² active electrode area. A single water electrolysis cell and two six-cell modules of 1.0 ft² active electrode area were designed and fabricated. The two six-cell 1.0 ft² modules incorporate 1.0 ft² unitized cores, which allow for minimization of module assembly complexity and increased tolerance to pressure differential. A water electrolysis subsystem was designed and fabricated to allow testing of the six-cell modules. After completing checkout, shakedown, design verification and parametric testing a module was incorporated into the Regenerative Fuel Cell System Breadboard (RFCSB) for testing at Life Systems, Inc., and at NASA JSC.

Background

The concepts and performance on which the present alkaline water electrolysis subsystem is based are described below.

Regenerative Fuel Cell Orbital Energy Storage Concept

Multikilowatt, low earth orbit power systems will be required to conduct future extended missions in space. A basic premise is that essentially all the power generated will be derived from solar energy. This, then, identifies the need of an Energy Storage System to supply the power demand during the dark side of each orbit.

The fuel cell has been the primary electrical power source for all United States manned space programs except Mercury because of superior flexibility, weight and cost factors. A Regenerative Fuel Cell System (RFCS), which consists of a dedicated Water Electrolysis Subsystem (WES), a Fuel Cell Subsystem (FCS), reactant and water storage assemblies and controls, is a major candidate for the Energy Storage System on the basis of projected launch weight, efficiency, volume, adaptability to cyclic operation and the existence of a strong technology base on which to build. The Regenerative Fuel Cell Orbital Energy Storage Concept is shown in Figure 1.

The electrolyzer and fuel cells can each use either alkaline or an acid electrolyte. To be competitive with other storage concepts, however, requires that the electrochemical subsystem minimize the need for parasitic power, be highly reliable and operate at a high electrical-to-electrical efficiency. These requirements are met by an RFCS using an alkaline electrolyte, an approach with extensive development history and, for the fuel cell, a flight pedigree.

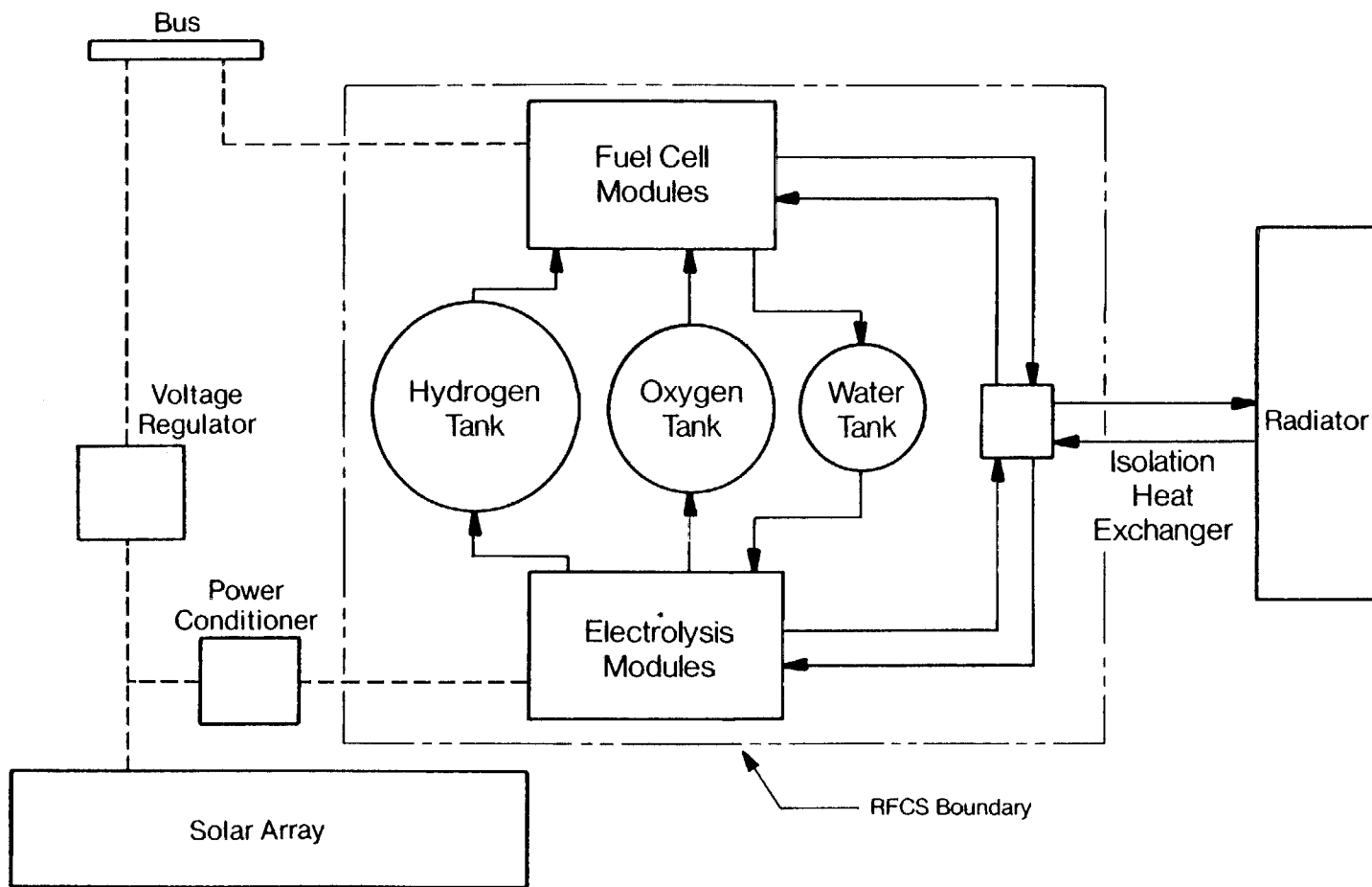

FIGURE 1 REGENERATIVE FUEL CELL ORBITAL ENERGY STORAGE CONCEPT

Static Feed Water Electrolysis Concept

Detailed descriptions of the static feed process, its theory of operation and its performance have been discussed previously. (2,3,4) The following subsections briefly summarize the electrochemical reactions and the cell level and subsystem concepts involved.

Basic Process. A water electrolysis cell dissociates water into its component elements of H_2 and O_2 by supplying electrons to a negatively charged electrode (cathode) and removing electrons from a positively charged electrode (anode). The half-cell reactions for water electrolysis cells using an alkaline electrolyte are as follows:

At the cathode:

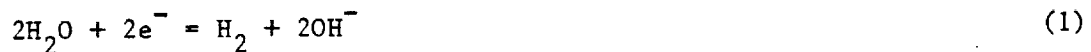

At the anode:



These result in the overall reaction of:

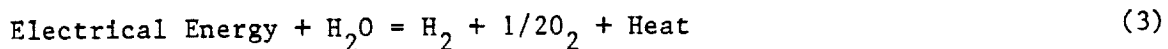

The Static Feed Water Electrolysis Cell. The extent to which these reactions can be used for practical and efficient O_2/H_2 generation is, however, highly dependent on cell technology. Figure 2 is a functional schematic of the SFE cell.

The SFE concept works as follows (refer to Figure 2). Initially, both the water feed cavity and the cell matrix have equal concentrations of electrolyte. As electrical power is supplied to the cathode and anode electrodes, water is electrolyzed from the cell matrix electrolyte creating a concentration gradient between the electrolyte in the water feed cavity and the electrolyte in the cell matrix. Water vapor diffuses from the water feed matrix into the cell matrix due to this gradient. Consumption of water from the water feed cavity results in its static replenishment from an external water supply tank. Major advantages are that:

1. No moving parts are required since the water feed mechanism is entirely passive and self-regulating based upon the demands of the electrolyzer.
2. No liquid/gas separators are needed.
3. Virtually no feed water pretreatment is needed, because contact between the liquid feed water and the cell electrodes does not occur, thus preventing feed water contaminants from poisoning the electrode catalysts.

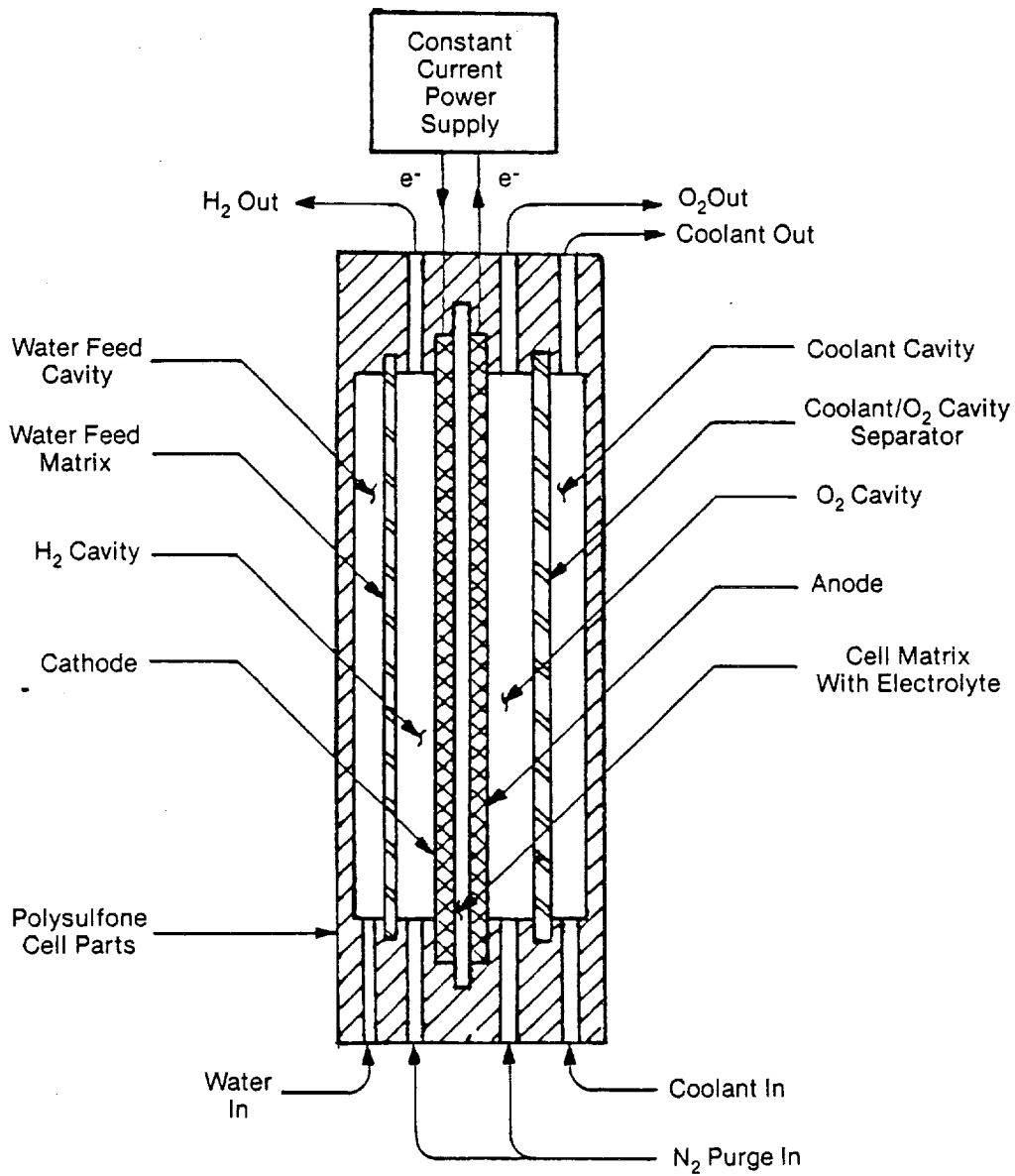

FIGURE 2 CELL FUNCTIONAL SCHEMATIC

These features contribute to simple operation and long life. As shown in Figure 2, waste heat generated by the electrochemical reaction is removed by a liquid coolant circulating through a compartment adjacent to the O₂ generation cavity. The N₂ purge, not required during normal cell operation, is used prior to performing maintenance and assists in pressurizing and depressurizing the cell during startup and shutdown, respectively.

Subsystem Concept. In a static feed water electrolysis subsystem, the electrochemical module is integrated with only three major supporting components consisting of mechanically integrated assemblies of valves, pumps, pressure regulators and sensors. These components are:

1. The Coolant Control Assembly (CCA) - supplies a constant flow of controlled, variable temperature liquid coolant to the SFE module.
2. The 3-Fluids Pressure Controller (3-FPC) - maintains the absolute and differential pressures in the subsystem and controls pressurization and depressurization of the subsystem during start-ups and shutdowns.
3. The Fluids Control Assembly (FCA) - controls and monitors the SFE water tank fill, water feed and purge gas supplies.

A functional schematic of the water electrolysis subsystem is shown in Figure 3.

The water electrolysis subsystem is controlled by computer-based instrumentation. Life Systems' standard development instrumentation package provides for parameter control, automatic mode and mode transition control, automatic shutdown for self-protection, monitoring of subsystem parameters and interfacing with data acquisition facilities. The control of the subsystem is fully automated by the Control and Monitor Instrumentation (C/M I) so that the operator only needs to press the desired mode button to initiate a start-up or any mode transition sequence.

State-of-the-Art Cell Performance Base

The key performance-indicating parameter of a WES is the voltage of the individual cells, because the power required to produce H₂ and O₂ at a given rate is directly proportional to that voltage.

WES development activities at Life Systems have resulted in substantial improvements in operating cell voltages at practical current density levels. These reductions were achieved primarily by reducing the overvoltage at the O₂-evolving electrode (anode). Operation with improved anodes was previously characterized at cell and module levels.⁽⁴⁾ These results provided the design basis for the 1.0 ft² cells.

Program Objectives

The primary objectives of the program are to:

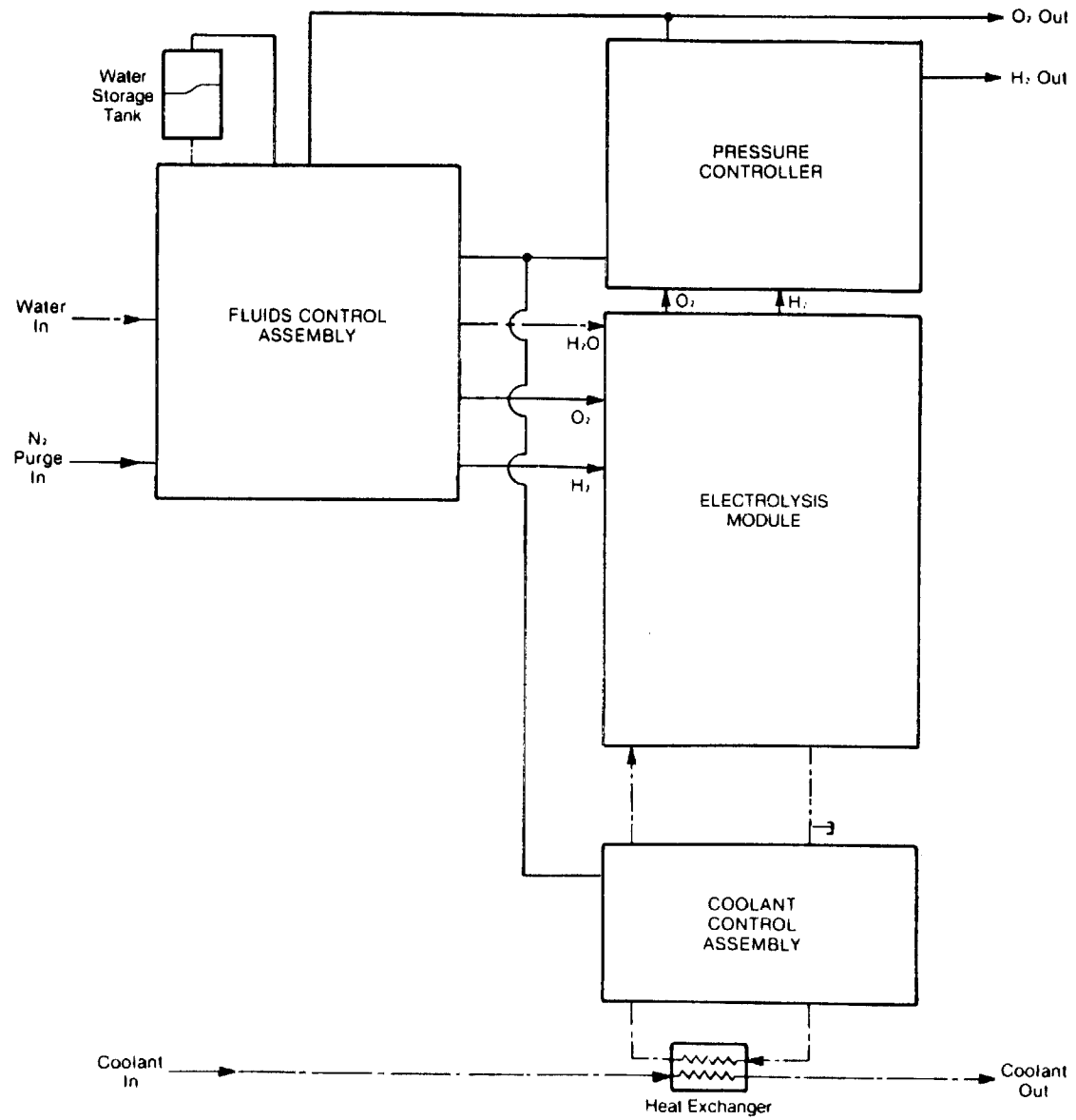

FIGURE 3 STATIC FEED WATER ELECTROLYSIS SUBSYSTEM SCHEMATIC

1. Assess the current state of alkaline water electrolysis technology and its capability potential as part of a RFCS of a multikilowatt orbiting powerplant.
2. Design and fabricate a single water electrolysis cell and two six-cell electrolyzer modules of nominally 1.0 ft² active electrode area.
3. Design and fabricate a Water Electrolysis Subsystem (WS-6 SN01) to allow testing of a six-cell 1.0 ft² electrolyzer module. Perform checkout, shakedown, design verification, parametric and acceptance testing and deliver the six-cell module to NASA JSC.
4. Modify and upgrade advanced test facility hardware with mechanically integrated components (3-FPC, CCA, FCA) to allow 30 days of cyclic endurance testing of the second six-cell 1.0 ft² electrolyzer module (WS-6 SN02).
5. Develop the 1.0 ft² unitized core which provides for performance reproducibility, assembly simplicity and increased module tolerance to pressure differentials.
6. Continue the endurance testing of four ambient pressure Static Water Electrolysis Cells (SWECS), two operating with constant current and two operating with cyclic current.
7. Continue the endurance test of a 0.1 ft² SWEC with unitized cell core at high pressure (200 psig).
8. Submit an Interim Report summarizing results through December 1984.
9. Deliver a range of program documentation from Program Plan through Final Report.

End Items

The following end items resulted from the program activities reported herein:

1. An optimized 1.0 ft² cell design based on the static feed concept and using 1.0 ft² unitized cell cores was developed.
2. A six-cell electrolyzer module based on the optimized 1.0 ft² design was tested for 500 hours, integrated into a RFCSB and delivered to NASA JSC.
3. A second six-cell electrolyzer module was fabricated based on the optimized 1.0 ft² design and tested for 30 days.
4. A Water Electrolysis Subsystem (WS-6) was developed that allowed testing of a six-cell 1.0 ft² electrolyzer module.

5. Modified and upgraded test facility hardware (3-FPC, CCA, FCA/WES) to allow testing of six-cell 1.0 ft² electrolyzer modules.
6. Endurance tested two alkaline water electrolysis cells at constant conditions for an additional 20,000 hours.
7. Endurance tested two alkaline water electrolysis cells at cyclic conditions for an additional 20,000 hours.
8. Endurance tested one Static Water Electrolysis Cell (SWEC) at high pressure (200 psig) for an additional 10,000 hours.
9. Endurance tested one SWEC with 0.1 ft² unitized cell core at high pressure (200 psig) for 1,000 hours.
10. Completed a Regenerative Fuel Cell System (RFCS) study and an Engineering Model System (EMS) Design Definition Study including delivery of a formal study report.
11. Fabricated and delivered 150 porous screen electrodes.
12. Delivered a range of program documentation from Program Plan through Interim Report.

Program Organization

To meet the above objectives, the program was divided into two phases: Phase 1 completing the original program scope and Phase 2 for added program scope. The original program scope consisted of thirteen tasks while the added program scope had seven tasks.

1.0 FT² WATER ELECTROLYSIS CELL AND MODULE DEVELOPMENT

Life Systems initially demonstrated the feasibility of scaling up the SFE cell design from 0.1 ft² active area to 1.0 ft² active area under an Internal Research and Development (IRAD) program. A "first generation" 1.0 ft² cell was then extensively tested. (5) Test results were reviewed to identify possible modifications and refinements that had to be incorporated in order to meet the unique requirements of the space power RFCS application. (5)

1.0 Ft² Cell Frame Development

The following changes were implemented into the 1.0 ft² cell frame design for space power RFCS application. The resulting new 1.0 ft² cell frame is shown in Figure 4.

- The hydraulic radius of the water feed channel was increased by approximately 33% over that of the smaller 0.1 ft² cell. The larger channel is more compatible with larger water consumption due to the larger cell area.

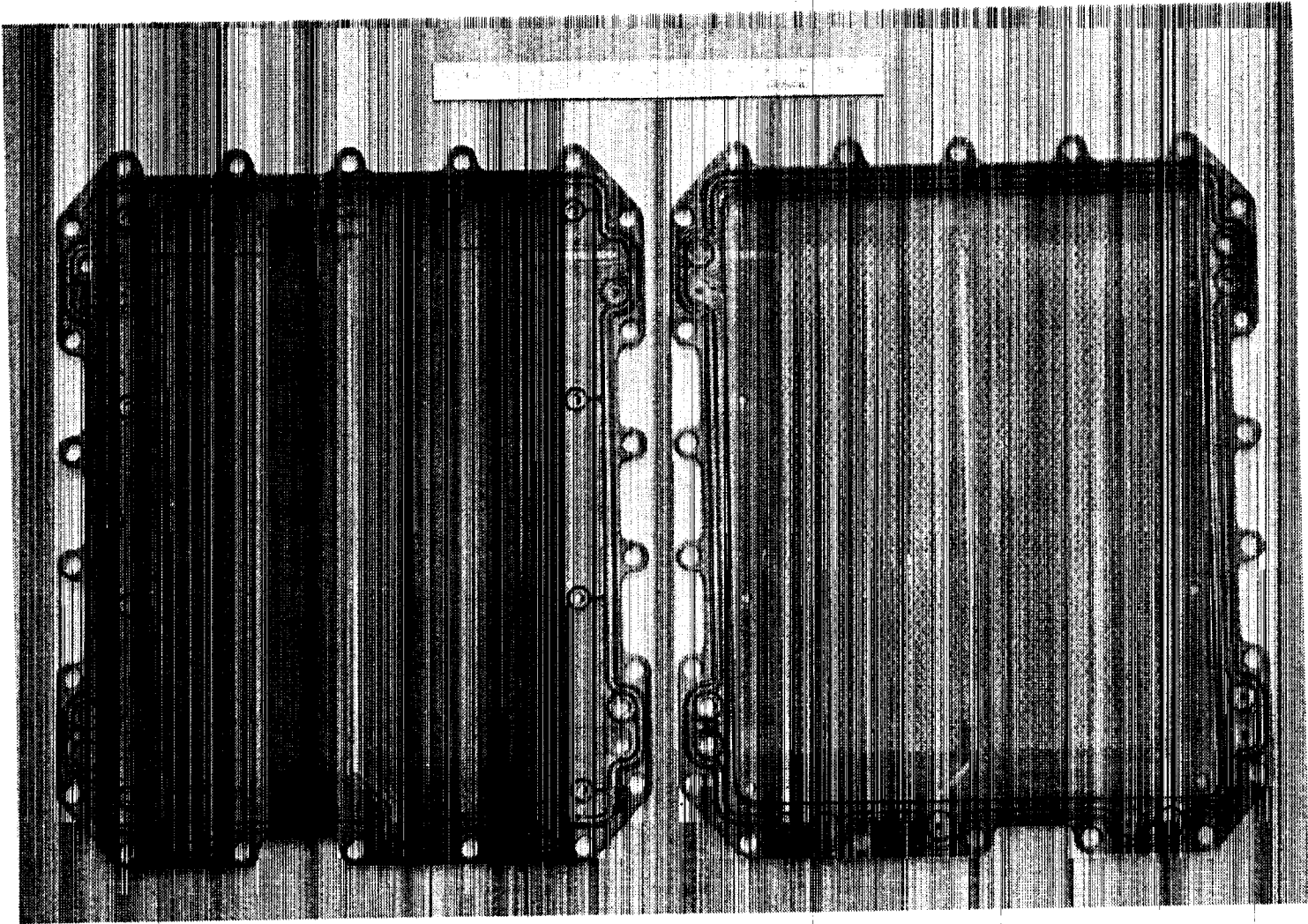

FIGURE 4 1.0 FT² CELL FRAME

- In previous cell/module designs, the feed cavities of all cells stacked in series were interconnected via two circulation ports to provide application flexibility. A RFCS cell does not employ a circulating water feed compartment fluid loop. The 1.0 ft² cell was designed with provisions for circulation ports, but the holes are blocked to isolate the feed cavity of each cell from all the others in the stack. If an application necessitates the circulation of the water feed compartment fluid through the module, this can easily be accomplished by opening the ports.
- An area of improvement identified in previous SFE cell designs was the pattern of the polysulfone support pegs in the water feed cavity. The purpose of the support peg is to maintain even compression throughout the cell while allowing sufficient void volume for liquid in the water feed cavity. A polypropylene support screen serves to maintain that internal cell compression is applied over the top of the pegs. Previous tests conducted under this program found that the support screen would sag in the area between two support pegs resulting in loss of some compression with time and a slight increase in cell voltage. In the 1.0 ft² design, a diamond peg pattern is used (versus round peg pattern in 0.1 ft² cells) to shorten the unsupported length between any two support pegs. This provides better compression in the cell and minimizes deflection of the support screens.
- Previous SFE cell designs required the use of many small O-rings. The quantity of O-rings added complexity and time to module assembly. In the 1.0 ft² SFE cell design continuously molded O-rings are used to replace the individual small O-rings. An added design feature of the specially molded O-rings is that each gas or liquid port has at least a double O-ring seal to ambient or to another cavity. With the molded O-rings, module assembly is both easier and quicker. The molded O-rings are designed for internal to external pressure differential of up to 500 psid.
- The intercell, bi-polar electrical current transfer path was modified to decrease internal resistance losses by using eight versus four connections per cell. Figure 5 illustrates the 1.0 ft² cell design in cross-section. Electrical current passes from the anode current collector (bi-polar plate) of one cell, through the cell, into the cathode current collector and then into the current collector studs by means of current collector screws. The current then continues to flow into the bi-polar plate (anode current collector) of the next cell and through each cell connected in the series stack.
- The anode current collector was modified to provide greater strength and lower IR losses. This was accomplished by increasing the thickness of the anode current collector from 0.020 inches to 0.030 inches.

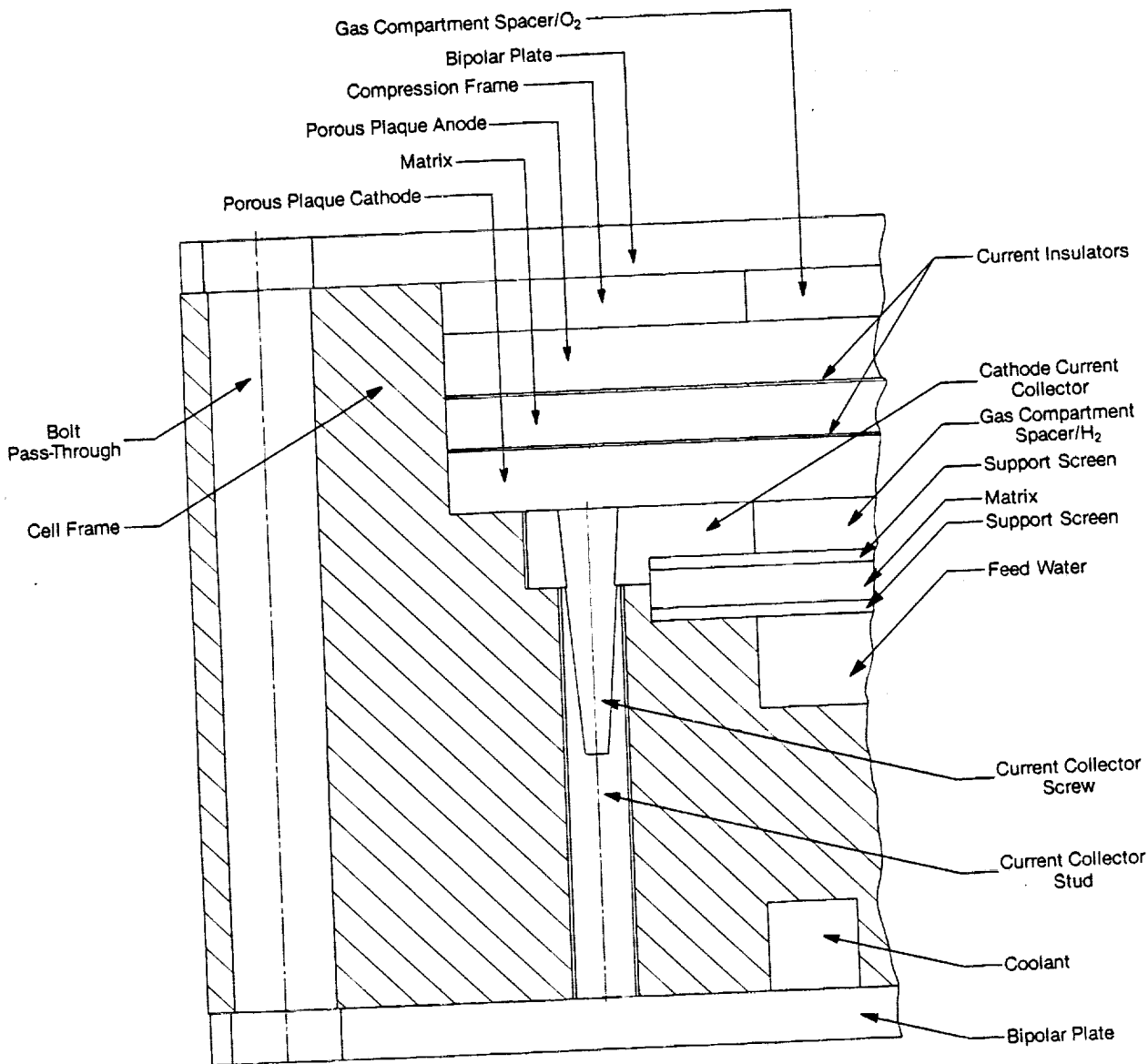

FIGURE 5 1.0 FT² SINGLE CELL CROSS SECTIONAL VIEW

1.0 ft² Multicell Module Development

In order to meet the requirements of the space power RFCS application, the development of a weight-optimized water electrolysis module was completed. Significant weight reductions were realized in new designs for cell frames, insulation plates, end plates and other module parts. The major contribution to overall weight reduction was through the use of lightweight aluminum core, honeycomb end plates. Other considerations in the module design involved the reduction of possible current paths for stray electrolysis in the O₂ outlet manifolds and the incorporation of current buss bars into the insulation plates for even current distribution.

The most attractive feature of the new 1.0 ft² cell/module designs is the light weight. From an initial weight of 357.6 lb using a first generation cell design, the 1.0 ft² multicell module weight was reduced by 66% to 139.3 lb. A weight comparison is shown in Table 1.

The following is a summary of key weight reductions:

- a. Cell Frame: The weight of the polysulfone frame housing was reduced from 3.6 lb to 1.8 lb. The weight savings are due primarily to an overall reduction in non-productive areas of the cell frame. The first generation cell frame had overall dimensions of 17.00 in x 22.20 in x 0.31 in (H x W x L) while the newly designed cell frame has its overall dimensions reduced to 15.50 in x 18.83 in x 0.31 in for the same active area of 1.0 ft².
- b. Insulation Plates: The total weight of the two polysulfone insulation plates was reduced from 72.4 lb to 13.5 lb. The weight savings is due to overall size reductions similar to those of the cell frame. The thickness of each insulation plate was decreased significantly from 2.14 in for each the structural and fluids insulation plate to 0.8 in and 0.4 in respectively.
- c. Current Buss: A modification was incorporated into the module design to improve current transfer to and from the electrolyzer module while still reducing weight. The copper current buss bars, which had previously been external to the module, are now embedded into the polysulfone insulation plates. Figure 6 shows the Fluid and Structural Insulation Plates with Current Buss Bars for the 1.0 ft² module. This reduced weight from 20 to 14 lb and will also allow for more efficient packaging of 1.0 ft² modules in future applications as well as in the WS-6 subsystem. In order to facilitate current connections between the module and the power supply, "quick-connect" current connectors were chosen for use with the module. This eliminates the need for removal of any bolts, nuts or washers when making current connections to the module.
- d. Lightweight End Plates: Aluminum honeycomb, stainless steel honeycomb, fiberglass reinforced epoxy, and cross-ribbed stainless steel were among the lightweight end plate designs investigated. The honeycomb design was the most efficient in terms of weight and

TABLE 1 1.0 FT² MODULE HARDWARE WEIGHT SUMMARY

| Item | First Generation Design | | Lightweight RFCS Design | |
|------------------------------|-------------------------|------------------|-------------------------|--------------------|
| | Unit Weight, lb | Total Wt, lb (a) | Unit Weight, lb | Total Wt, lb (a) |
| Cell Frame | 3.6 | 21.6 | 1.8 | 10.8 |
| Current Coll., Mid Anode | 2.4 | 12.0 | 2.9 | 14.5 |
| Current Coll., End Anode | 2.4 | 4.8 | 2.9 | 5.8 |
| Current Coll., Cathode | 0.5 | 3.0 | 0.4 | 2.4 |
| Anode | 1.5 | 9.0 | - | - |
| | | | 1.2 ^(b) | 1.2 ^(b) |
| Cathode | 1.5 | 9.0 | - | - |
| Insulation Plate, Structural | 36.2 | 36.2 | 8.6 | 8.6 |
| Insulation Plate, Fluids | 36.2 | 36.2 | 4.9 | 4.9 |
| End Plate, Structural | 92.5 | 92.5 | 26.0 | 26.0 |
| End Plate, Fluids | 92.5 | 92.5 | 29.2 | 29.2 |
| Bolts | 20.0 | 20.0 | 0.4 | 20.9 |
| Miscellaneous | 0.8 | 0.8 | 0.5 | 3.0 |
| Current Buss | 10.0 | <u>20.0</u> | 6.0 | <u>12.0</u> |
| Total | | 357.6 | | 139.3 |

(a) For a six-cell module.

(b) Utilizing unitized core.

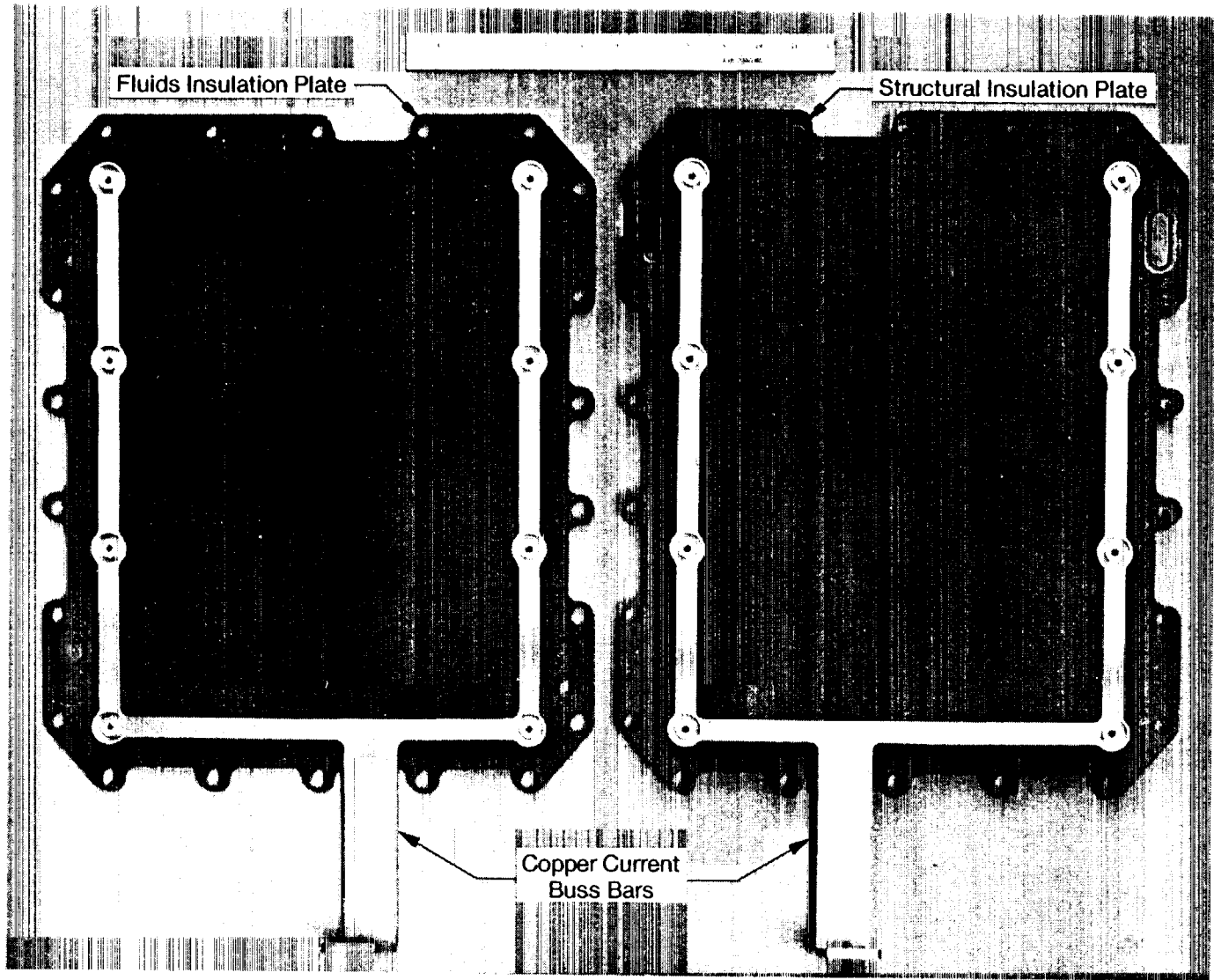

FIGURE 6 FLUIDS AND STRUCTURAL INSULATION PLATES WITH CURRENT BUSS BARS FOR 1.0 FT² MODULE

deflection. Because of availability and lower cost, the aluminum honeycomb core was selected over its stainless steel counterpart for fabrication of the end plate. The facing material of the end plate is stainless steel which is compatible with the aluminum honeycomb core. The total weight of the two end plates was reduced from 185.0 lb to 55.2 lb. The detailed design of the end plates is further discussed below.

The six-cell 1.0 ft² module was designed to produce H₂ at a rate of 0.07 lb/hr and O₂ at a rate of 0.59 lb/hr at the nominal operating conditions of 180 F, 300 psia and 150 ASF. Normal Mode operating characteristics for a six-cell 1.0 ft² module are shown in Table 2.

O₂ Port Isolation

Under a NASA JSC sponsored development program for the RFCSB, first time testing of a 30-cell electrolysis module showed that small amounts (0.2%, approximately) of H₂ were present in the O₂. This was traced to undesirable stray electrolysis in the O₂ manifold and in the O₂ passage through the metallic end plate. This stray electrolysis was caused by the potential (electrical) difference between the end plates and the exposed portion of the current collectors in the O₂ manifolds. In order to prevent stray electrolysis from occurring in the WS-6 module, modifications were made to the designs of the cell frame, insulation plate and end plate to completely isolate the O₂ manifolds from the current collectors and the end plates. The O₂ manifold isolation minimized the possibility of stray electrolysis. One of the major steps taken to isolate the O₂ manifolds from the end plates involved the design of the O₂ outlet and O₂ purge port turnarounds in the structural insulation plate. The turnarounds isolate the O₂ manifolds from the structural end plate which is the most electrically positive metallic surface in a SFWEM. In the fluids end plate, where the O₂ ports enter and exit the SFWEM and contact a stainless steel surface, polysulfone port insulators were incorporated into the SFWEM. The 7.2 in long O₂ port insulators significantly increase the path for any stray current in the module to the point where stray electrolysis is significantly reduced.

As another means of monitoring for undesirable O₂ and H₂ recombination in a SFWEM, a temperature sensor was added to the module. This temperature sensor is physically located at the point at which the O₂ streams exiting from each individual cell first join to form a single O₂ exit stream. This sensor would detect any high temperatures in the O₂ stream that might result from any H₂ and O₂ recombination. The sensor itself consists of three separate magnesium oxide thermocouples enclosed in one single assembly. The subsystem can choose to monitor one of the thermocouples or it can monitor all three thermocouples at one time. The time-response of the thermocouple is such that in the event of a high O₂ gas temperature, the system can be immediately shut down.

Unitized Core Development

The overall objectives of the 1.0 ft² unitized core development efforts were to achieve reproducible SFWE electrochemical performance, increased tolerance to differential cell pressures (ruggedness) and reductions in cell complexity at assembly time. The 1.0 ft² unitized core was designed for an operational differential pressure capability of 12 psid. Baseline cell pressure

TABLE 2 SIX-CELL 1.0 FT² MODULE OPERATING CHARACTERISTICS

| | |
|---|-----------------|
| H ₂ Generation Capacity, lb/hr | 0.07 |
| O ₂ Generation Capacity, lb/hr | 0.59 |
| DC Power (Nominal), W | 1,539 |
| Heat Rejection, W | 207 |
| No. of Cells | 6 |
| Cell Active Area, ft ² | 1.0 |
| Current Density, ASF | 150 |
| Cell Voltage, V (WAB-1, Advanced) | 1.71 |
| Temperature, F | 180 |
| Pressure, psia | 300 |
| Fixed Hardware Weight, lb | 139.3 |
| Dimensions, ft | 1.7 x 1.3 x 1.2 |
| Volume, ft ³ | 2.6 |

differentials are 3.5 ± 1.5 psid. The unitized core concept uses permanently bonded, versus individually sealed, cell components. The permanently bonded edge of a unitized core seals against an O-ring, rather than compressing asbestos as in previous baseline designs and, thus, achieves the higher tolerance to the H_2/O_2 differential pressures.

The design of the 1.0 ft^2 unitized core is based upon the design of a 0.1 ft^2 unitized core developed previously. Critical areas for scale up were:

- Increased differential thermal expansion of key unitized core materials due to the larger 1.0 ft^2 size.
- Larger unitized core manufacturing facilities required while still maintaining critical core tolerances.
- Retrofitting initial 1.0 ft^2 cell design to use the 1.0 ft^2 unitized cores.

As part of the detailed design for the 1.0 ft^2 unitized cores, each of these critical areas was addressed and resolved:

- Samples of core materials at the 1.0 ft^2 size were obtained and thermal expansion properties of these materials were tested. Problems and difficulties associated with the use of these materials were encountered but were successfully resolved.
- Manufacturing facilities for the larger cores were designed, fabricated, checked out and successfully used to fabricate 1.0 ft^2 cores.
- The design of the 1.0 ft^2 cell frame was able to be modified to incorporate the unitized core without increasing overall cell size.

The major design modification to the cell frame consisted of the addition of an O-ring groove. This O-ring, which seals along the outer edge of the unitized core provides the seal between the O_2 cavity and the H_2 cavity of the cell. The cell frame was also modified to allow for use of a modified polysulfone compression ring. This ring provides compression to the outer edges of the unitized core and provides outlet passageways for the O_2 produced.

Fabrication equipment needed to fabricate all unitized cores was set up and checked out. The fabrication equipment consists of a manufacturing press and two thermally controlled platens which are able to meet and maintain critical core tolerances.

Fabrication of the unitized cores involves the addition of epoxy impregnated fiberglass frames and rims to the perimeters of the cell electrodes and matrices. Typical parts involved in the fabrication of a unitized core are shown in Figure 7.

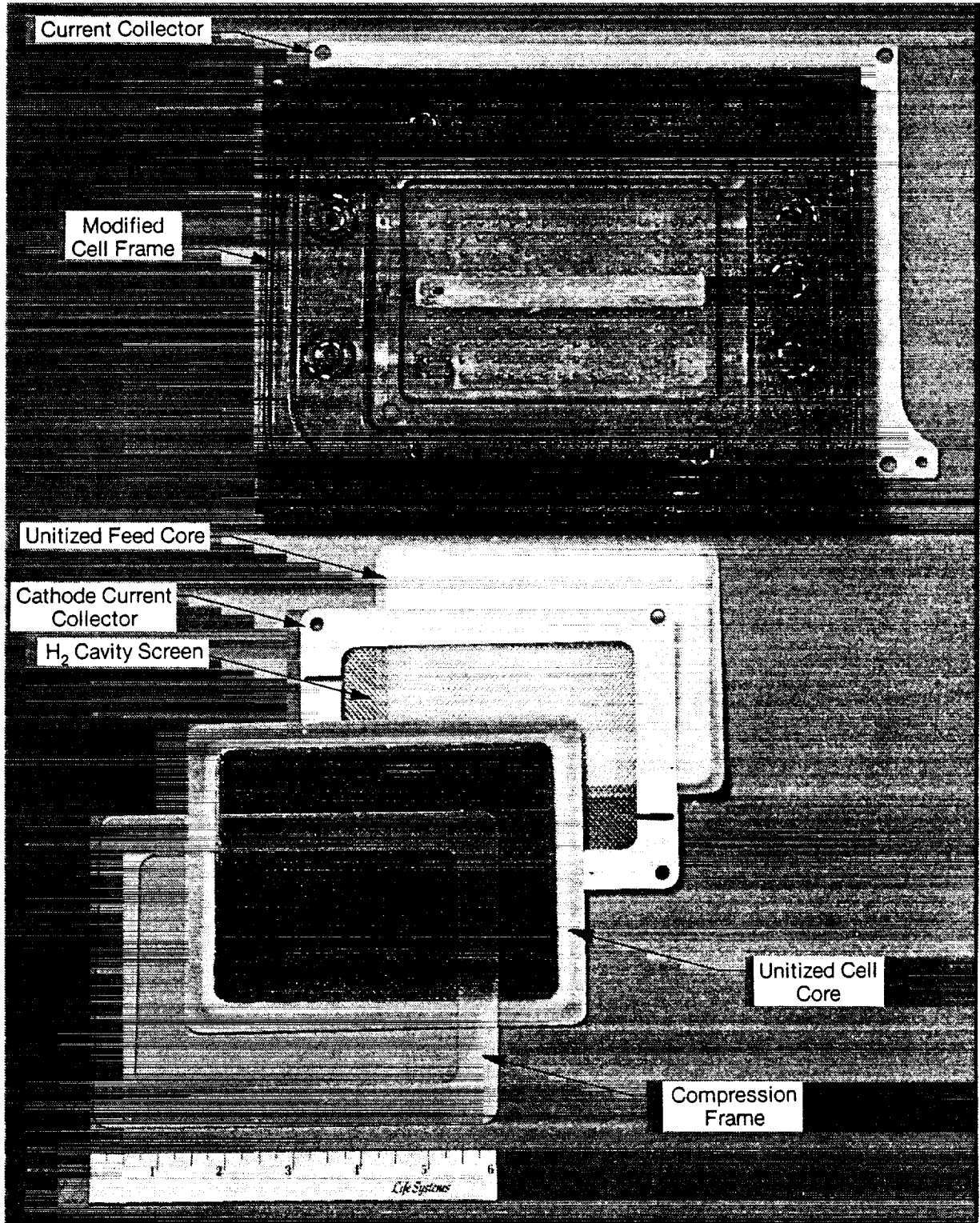

FIGURE 7 0.1 FT² UNITIZED CORE PARTS

The key structural material selected for the unitized cores was epoxy-impregnated fiberglass. Of the many fabrication materials studied, the epoxy-impregnated fiberglass was most compatible with the operating environment of the SFWE cell and exhibited the strength and rigidity needed. The epoxy/fiberglass did exhibit some porosity, however, so a compression seal between the various components of the cell and unitized core was selected over a chemical bonding type of seal. Critical points in the fabrication processes included maintaining proper widths, thicknesses and uniformities of individual components and the subsequent unitized core. The parameters were controlled using varied combinations of heat and pressure.

A total of 12 unitized cell cores₂ were fabricated for the two six-cell 1.0 ft² modules. Figure 8 shows a 1.0 ft² unitized core along with other 1.0 ft² cell parts. The cores exhibited differential pressure capabilities in excess of the design goal of 12 psid.

Light Weight End Plates

The objective of the lightweight end plate development effort was to reduce the overall end plate weight from 185.0 lb (First Generation Design) to a total weight goal of 60.0 lb. This goal was met through use of a honeycomb core end plate design. In addition to light weight, the end plate must also be rigid to keep the maximum deflection in the center of the end plate below 0.010 in. This deflection is critical because loss of compression due to excessive end plate deflection can result in large internal resistance losses in each cell which would contribute to higher module voltage.

Two types of end plate designs resulted for the six-cell 1.0 ft² module. The module was designed so that all fluidic and gaseous ports are located on one side of the module. This allows for module growth in number of cells without system level plumbing changes. The end plate with the fluid ports is termed the Fluids End Plate. The other end plate, without ports, is termed the Structural End plate. The structural end plate is completely isolated from contact with any gas or liquid from the module.

The honeycomb core of each end plate is 1/8 hexagonal Aluminum. The thickness of the core is 5.50 in and outer dimensions are 18.95 in by 15.59 in. The weight of each aluminum core is 9.0 lb. End plate face sheets, close-outs, bolt inserts, side channels and ports are 316 Stainless Steel. The thickness of each side channel and close-out is 0.044 in and the thickness of each face sheet is 0.050 in. All interface connectors for fluid and gas ports are O-Ring seal fittings.

One critical area of the end plate design is the development and selection of the end plate fittings and close-outs. Two types of end plate fittings are used in this design; bolt inserts and fluid port pass-throughs. The bolt inserts act as a structural tie and distribute high local forces over the entire end plate surface area. The port pass-throughs provide isolated flow paths for liquids and gases through the end plate structure. Both types of fittings are incorporated into the end plate structure during the bonding of

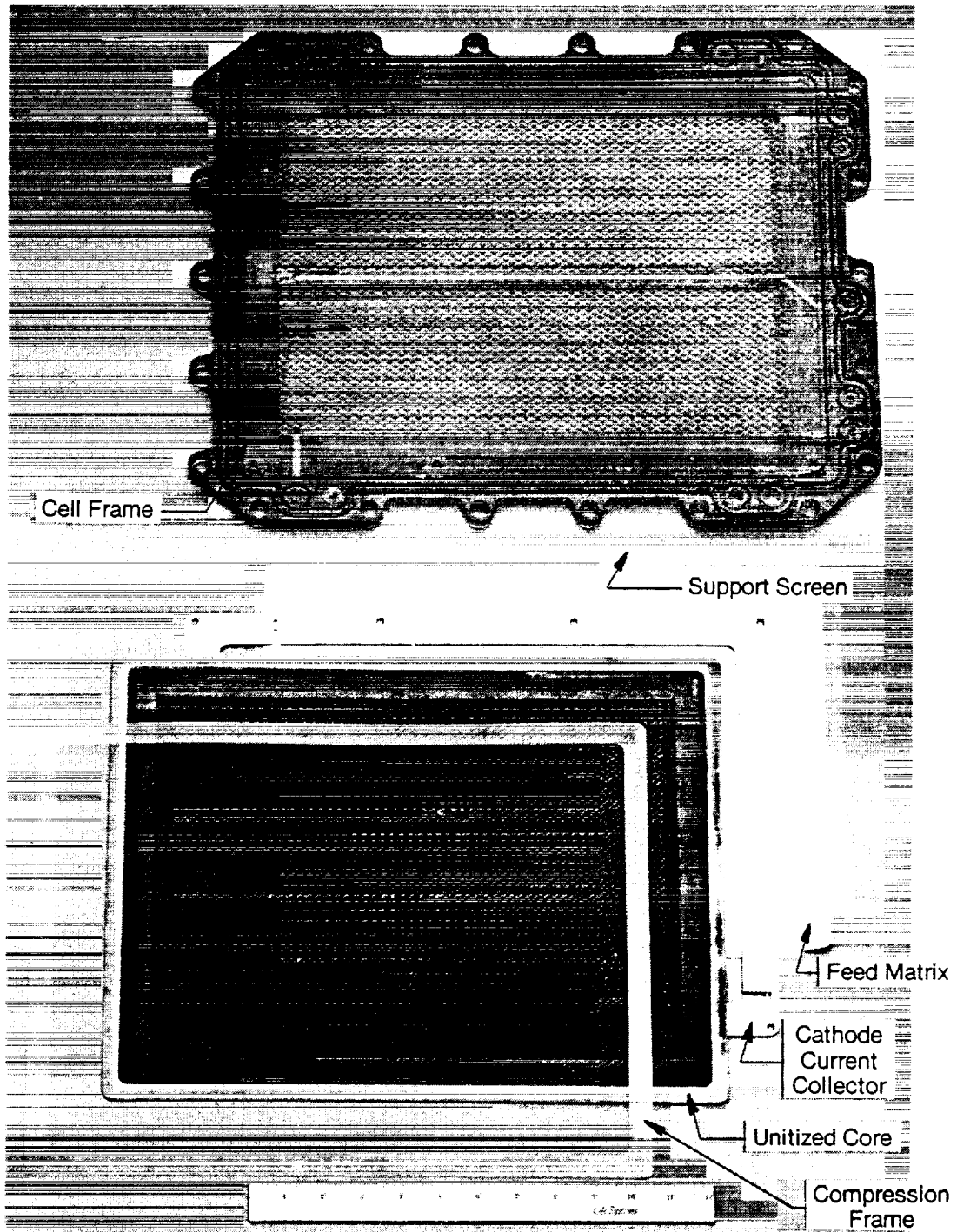

FIGURE 8 UNITIZED CORE CELL FRAME AND OTHER CELL PARTS

the sandwich panel as shown in Figures 9 and 10. The close-outs provide an edge protection against impact damage and a seal against any foreign materials coming into contact with the aluminum core. Like the end plate fittings, the close-outs are incorporated into the sandwich panel during fabrication as shown in Figure 11.

Upon completion of all end plate fabrication steps, the end plates were assembled with other module parts to form a six-cell 1.0 ft² electrolyzer. An isometric drawing of the six-cell 1.0 ft² electrolyzer with fluid ports labeled is shown in Figure 12. An actual, assembled six-cell 1.0 ft² electrolyzer is shown in Figure 13. The design of the end plates was verified during internal-to-external differential pressure checks of up to 300 psid. During the pressurization, dial indicators were placed at the center and edge of each end plate. As pressure was increased, measurements were taken for center-to-edge of end plate deflection. Deflection as a function of pressure is shown in Table 3 for both end plates. Both end plates satisfied the requirement for maximum deflection of 0.010 in.

The actual end plates more than met the goal for a total weight of 60.0 lb. The final weight of a Fluids End Plate is 29.2 lb and of a Structural End Plate 26.0 lb.

REGENERATIVE FUEL CELL ELECTROLYZER SUBSYSTEM (WS-6) DEVELOPMENT

The function of the Static Feed Water Electrolysis Subsystem (WS-6) is the generation of oxygen (O₂) and hydrogen (H₂) for potential use in a RFCS for energy storage aboard the projected Space Station. The WS-6 consists of the six-cell 1.0 ft² module for O₂ and H₂ production, a Pressure Controller for product gas and water feed pressure control, a Coolant Control Assembly (CCA) for module temperature control, a Fluids Control Assembly (FCA) for on/off control of fluids and the Control/Monitor Instrumentation package for automatic process control. The WS-6 will electrolyze 16.0 lb/day of H₂O while producing 14.19 lb/day of O₂ and 1.79 lb/day of H₂ when operating continuously at 150 ASF.

A mechanical schematic of the WS-6 subsystem is shown in Figure 14 while the WS-6 mechanical/electrochemical assembly is shown in Figure 15.

Design Specifications

The overall WS-6 design requirements which are compatible with the requirements that have been projected for the Space Station are shown in Table 4. The nominal design range for the WS-6 is: current density, 100 to 400 ASF; temperature, 120 to 200 F and pressure, 180 to 300 psia.

The WS-6 is designed to interface with other subsystems in the Space Station including the coolant supply and the Nitrogen (N₂) purge supply. These interfaces are simulated in the WS-6 with the Test Support Accessories (TSA) which is shown in Figure 16. The WS-6 interfaces are listed in Table 5.

The overall mass and energy balance for the WS-6 is shown in Figure 17. The operating conditions for this mass and energy balance are: current density, 150 ASF; temperature, 180 F; pressure, 300 psia.

FIGURE 9 INCORPORATION OF A TYPICAL PORT PASS-
THROUGH INTO END PLATE STRUCTURE

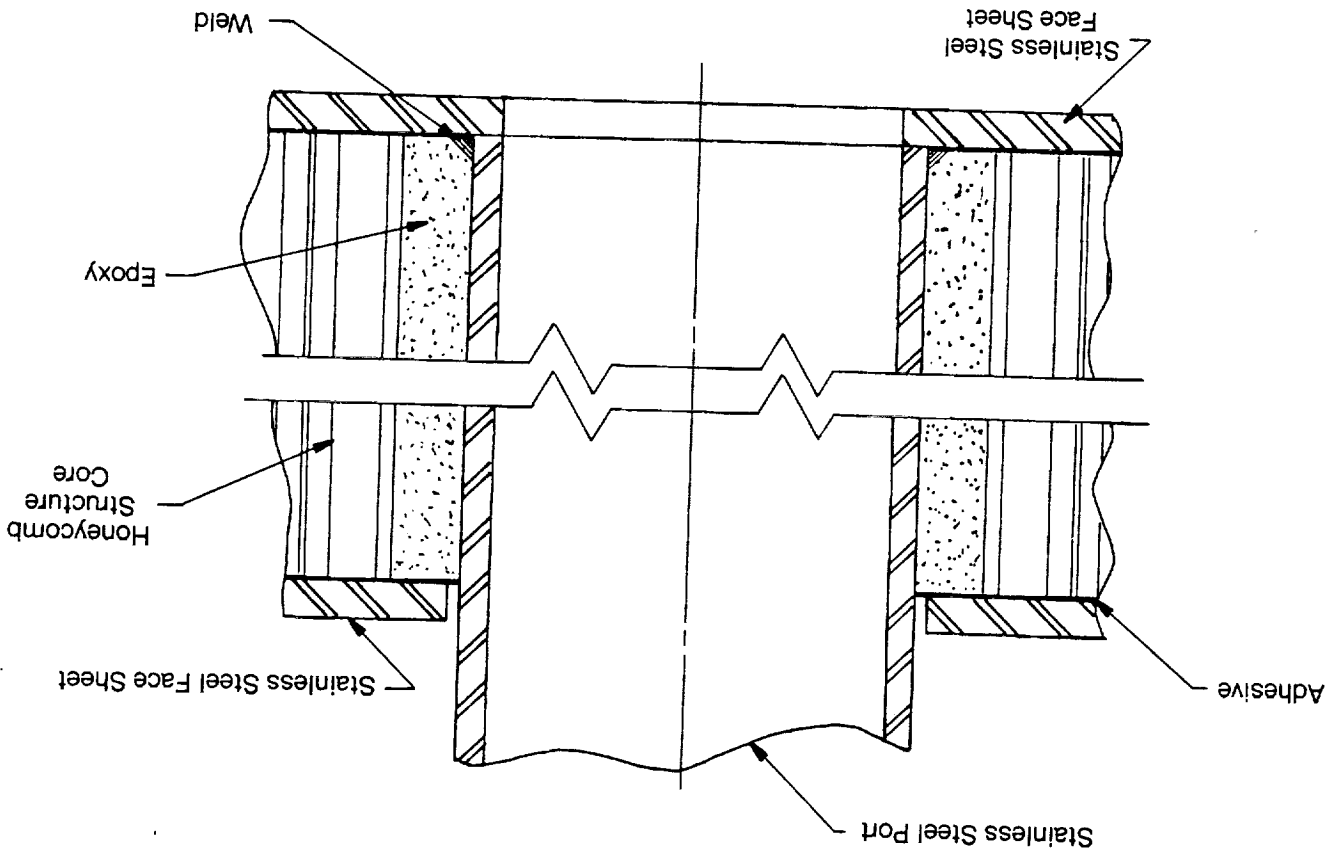
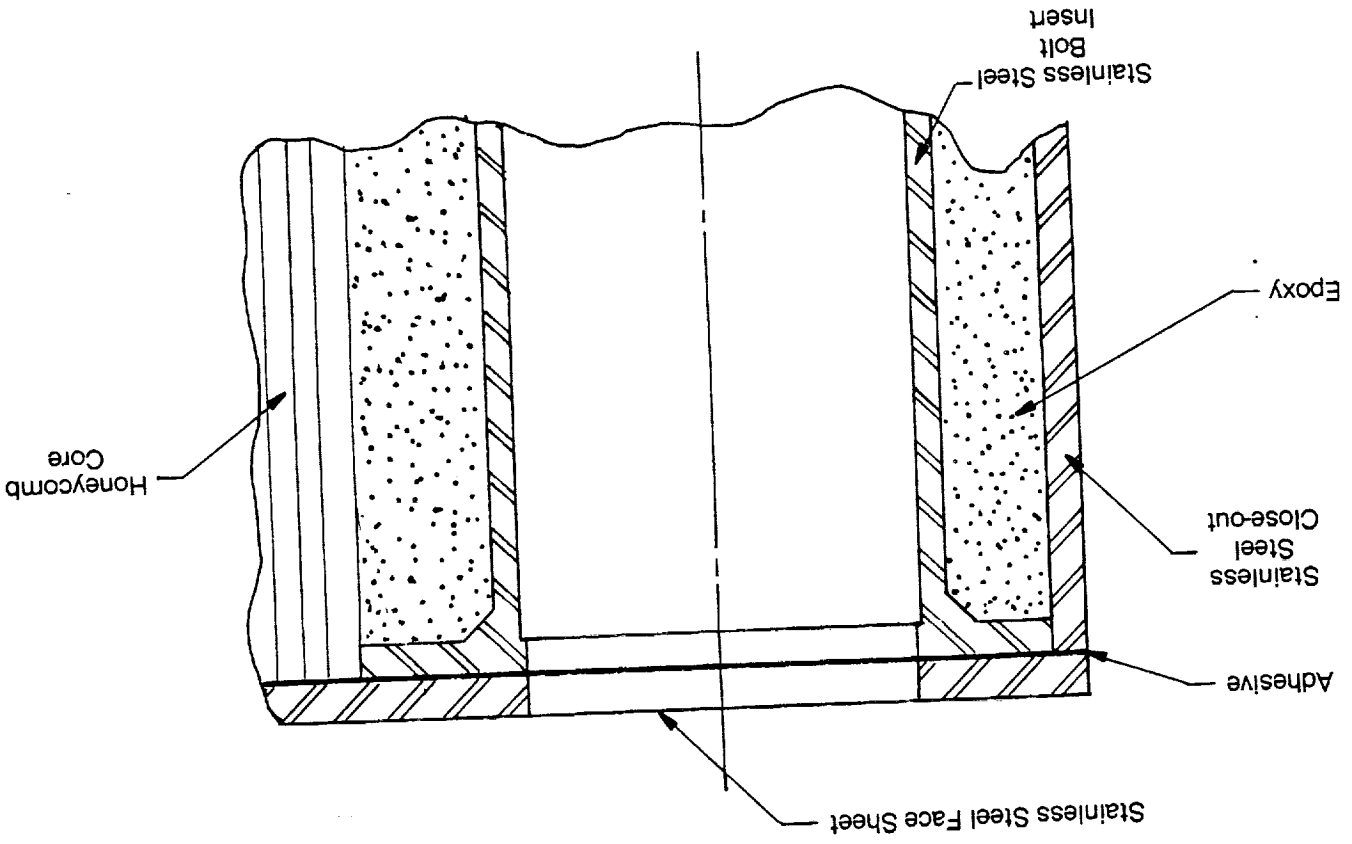

FIGURE 10 INCORPORATION OF A TYPICAL BOLT INSERT INTO ENDPATE STRUCTURE



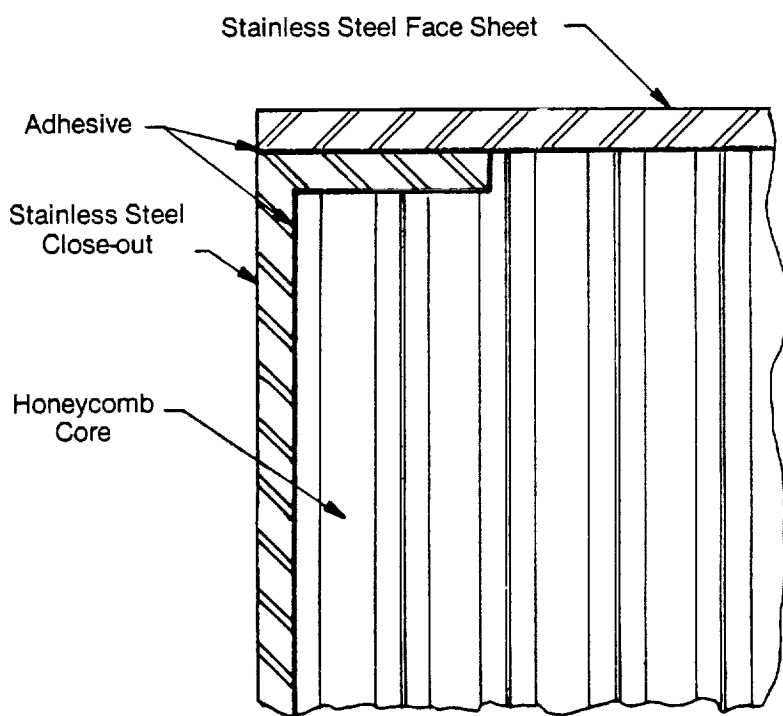

FIGURE 11 INCORPORATION OF CLOSE-OUTS INTO
END PLATE STRUCTURE

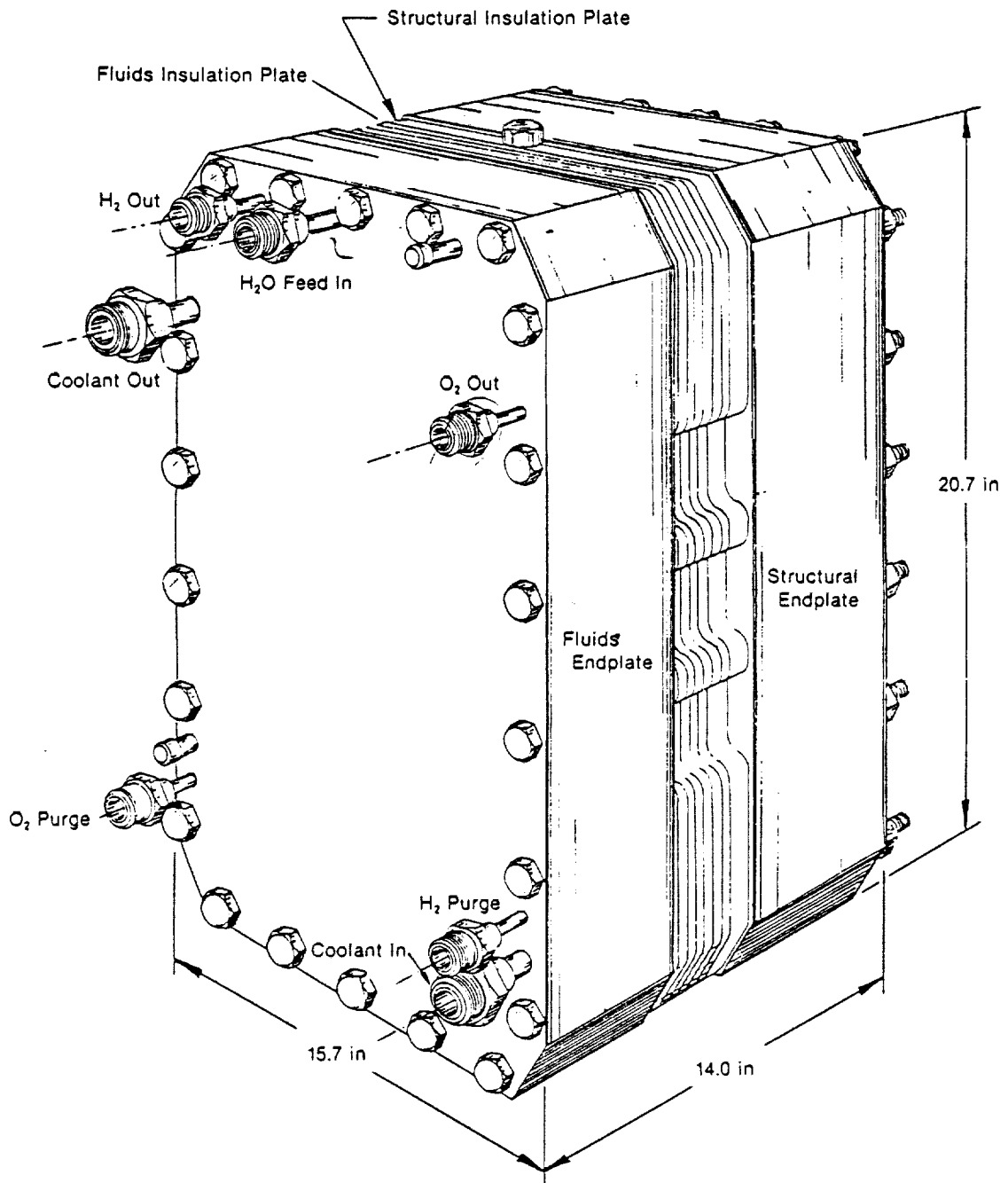

FIGURE 12 EXTERNAL VIEW OF SIX-CELL 1.0 FT² ELECTROLYZER MODULE

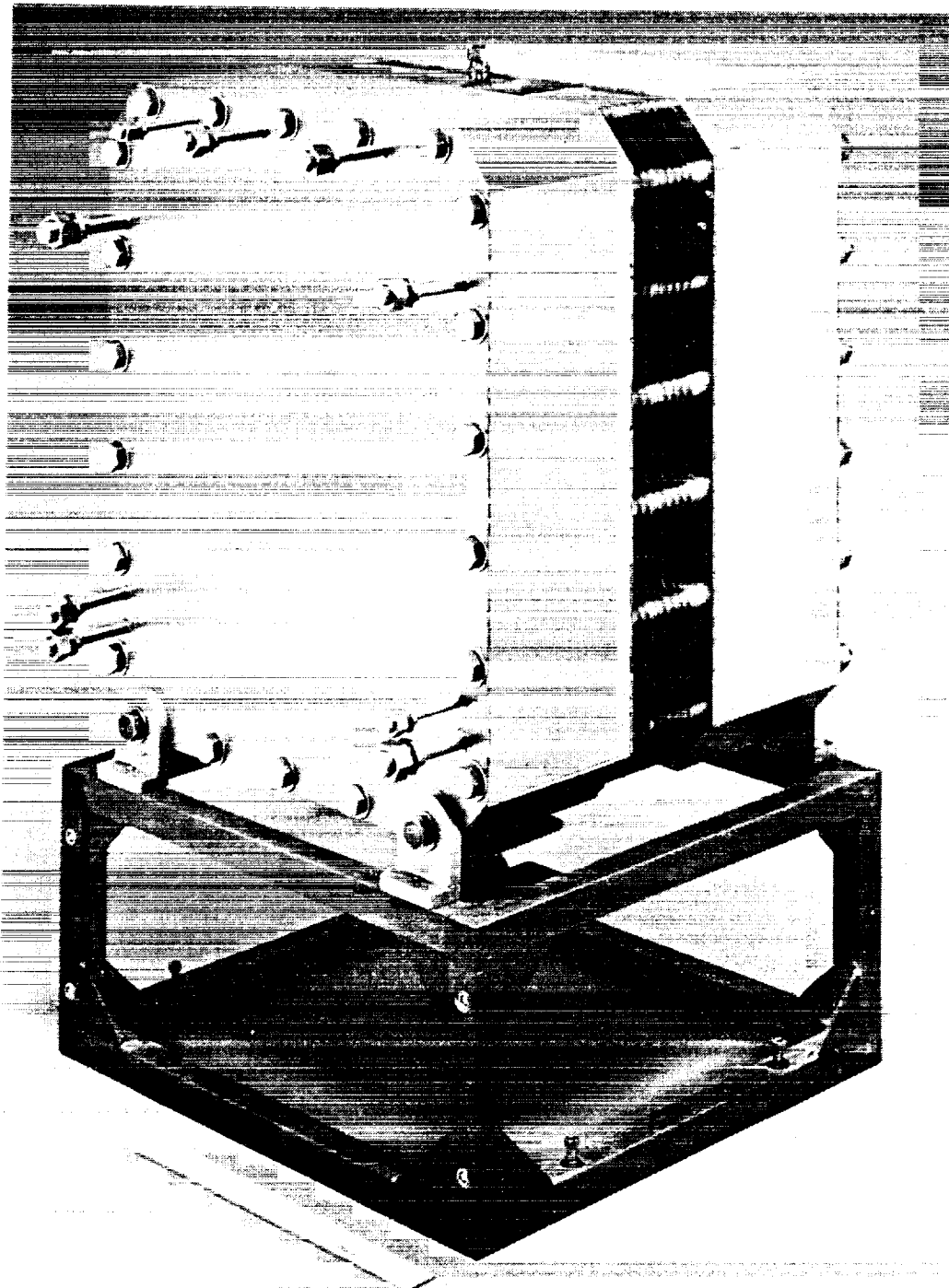

FIGURE 13 SIX-CELL 1.0 FT² WATER ELECTROLYSIS MODULE
WITH LIGHTWEIGHT HONEYCOMB END PLATES

TABLE 3 END PLATE CENTER DEFLECTION AS A FUNCTION OF PRESSURE^(a)

Fluids End Plate

| <u>Pressure, psig</u> | <u>Deflection, in</u> |
|-----------------------|-----------------------|
| 50 | 0.0017 |
| 100 | 0.0033 |
| 150 | 0.0047 |
| 200 | 0.0063 |
| 250 | 0.0075 |
| 300 | 0.0093 |

Structural End Plate

| <u>Pressure, psig</u> | <u>Deflection, in</u> |
|-----------------------|-----------------------|
| 50 | 0.0017 |
| 100 | 0.0041 |
| 150 | 0.0055 |
| 200 | 0.0071 |
| 250 | 0.0092 |
| 300 | 0.0100 |

(a) Bolt Torque: 20 ft-lb
 Bolt Material: Grade 8 Steel
 Honeycomb Material: 1/8 Aluminum
 End Plate Face Sheets: 316 SS

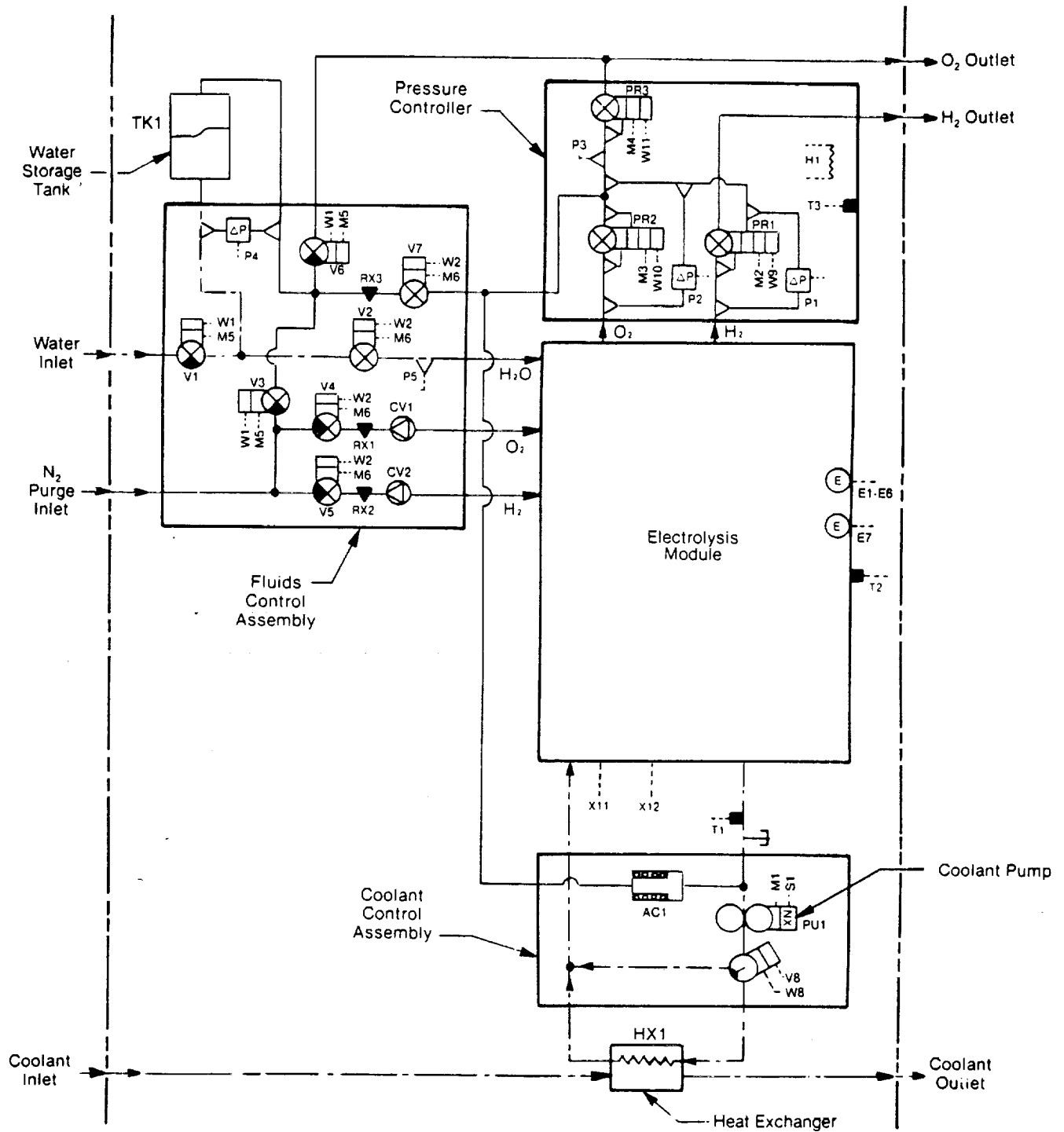

FIGURE 14 WS-6 SUBSYSTEM MECHANICAL SCHEMATIC WITH SENSORS

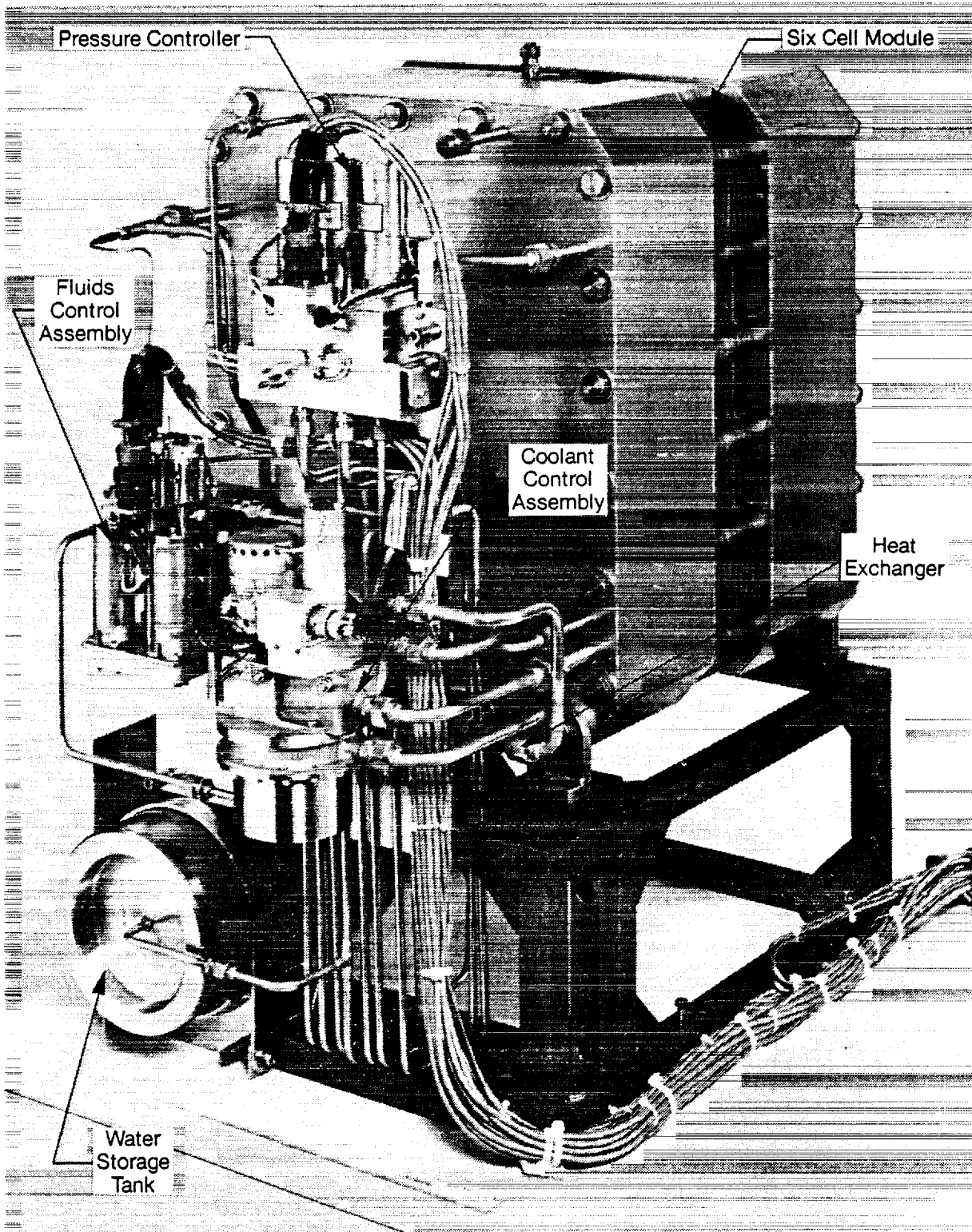

FIGURE 15 WS-6 MECHANICAL/ELECTROCHEMICAL ASSEMBLY

TABLE 4 WS-6 APPLICATION DESIGN SPECIFICATIONS

| | <u>WS-6 Development</u> | |
|---|---|----------------------------|
| H ₂ Generation Rate, lb/h | 0.05 to 0.20 ^(a) | |
| O ₂ Generation Rate, lb/h | 0.39 to 1.58 | |
| Operating Pressure Range, psia | 180 to 300 | |
| Operating Temperature Range, F | 120 to 200 | |
| Pressure Differentials (Max.), psid | | |
| O ₂ to H ₂ | 15.0 | |
| H ₂ to Water | 5.0 | |
| Performance (±0.005), V per Cell ^(b) | <u>Advanced^(c)</u> | <u>Super^(c)</u> |
| At 100 ASF | 1.57 | 1.44 |
| At 200 ASF | 1.66 | 1.51 |
| At 400 ASF | 1.80 | 1.63 |
| Water Supply | | |
| Pressure, psia | 30 | |
| Temperature, F | 40 to 80 | |
| Quality | Filtered (Activated Carbon), Saturated with Air at 14.7 psia | |
| Coolant | | |
| Fluid, External | Water | |
| Fluid, Internal | Fluorinert, FC40/FC75 | |
| Pressure, psia | 30 | |
| Source Temperature, F | ≤120 | |
| Water Feed Mechanism | Static | |
| Active Cell Area, ft ² | 1.0 | |
| Electrical Power, W | | |
| DC | 1,553 | |
| AC | 75 | |
| Purge Supply | | |
| Type Gas | N ₂ | |
| Pressure, psia | 300 | |

continued-

(a) Nominal Design Range; 100 to 400 ASF

(b) At 180 F.

(c) Anode electrode.

Table 4 - continued

| | <u>WS-6 Development</u> |
|---|-----------------------------|
| Emergency N ₂ Purge Pressure, psia | Not Applicable |
| Packaging | Self-contained |
| Allowable Downtime, h | 8 to 48 |
| Allowed Duty Cycles | Continuous and Cyclic |

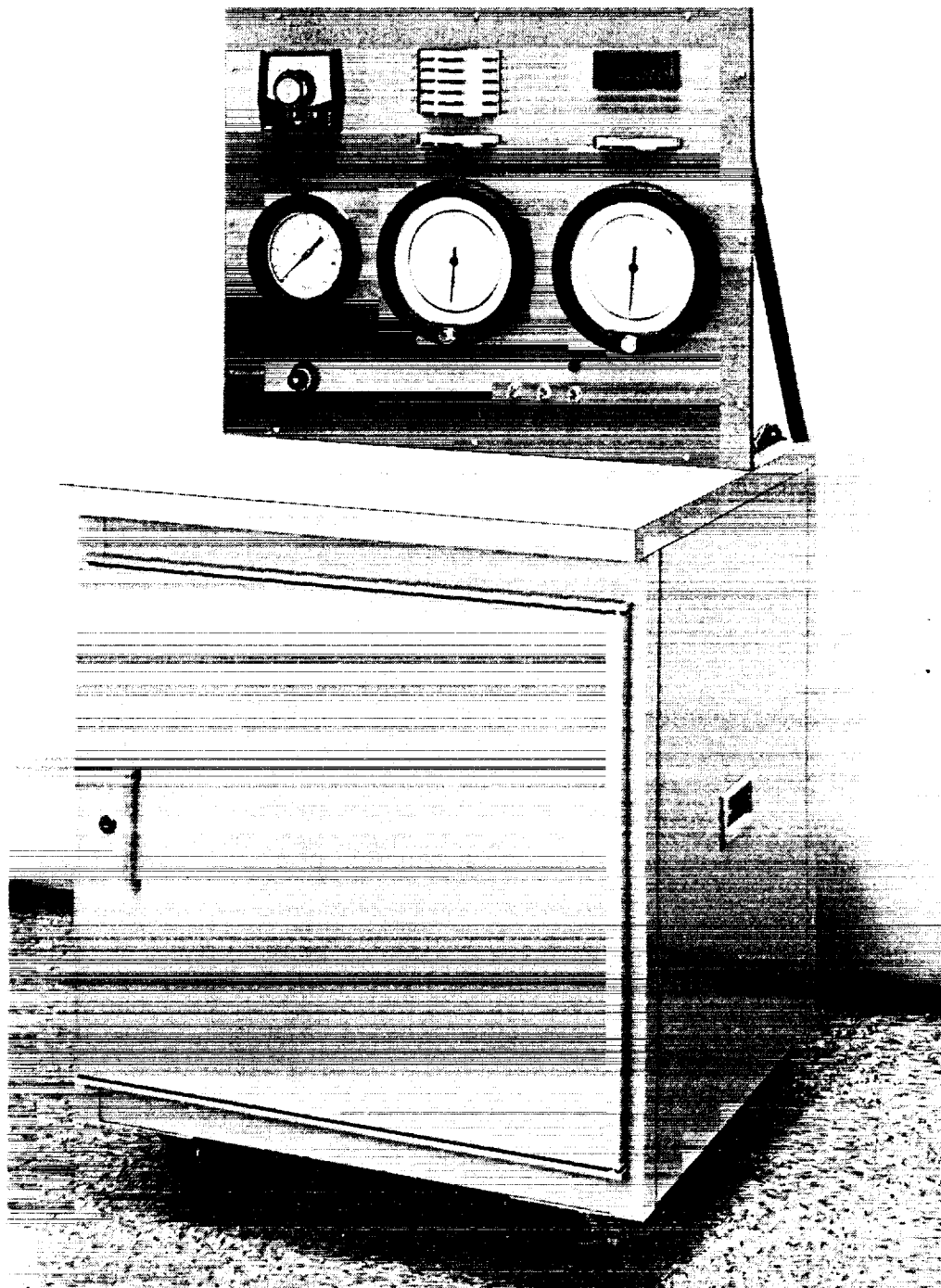
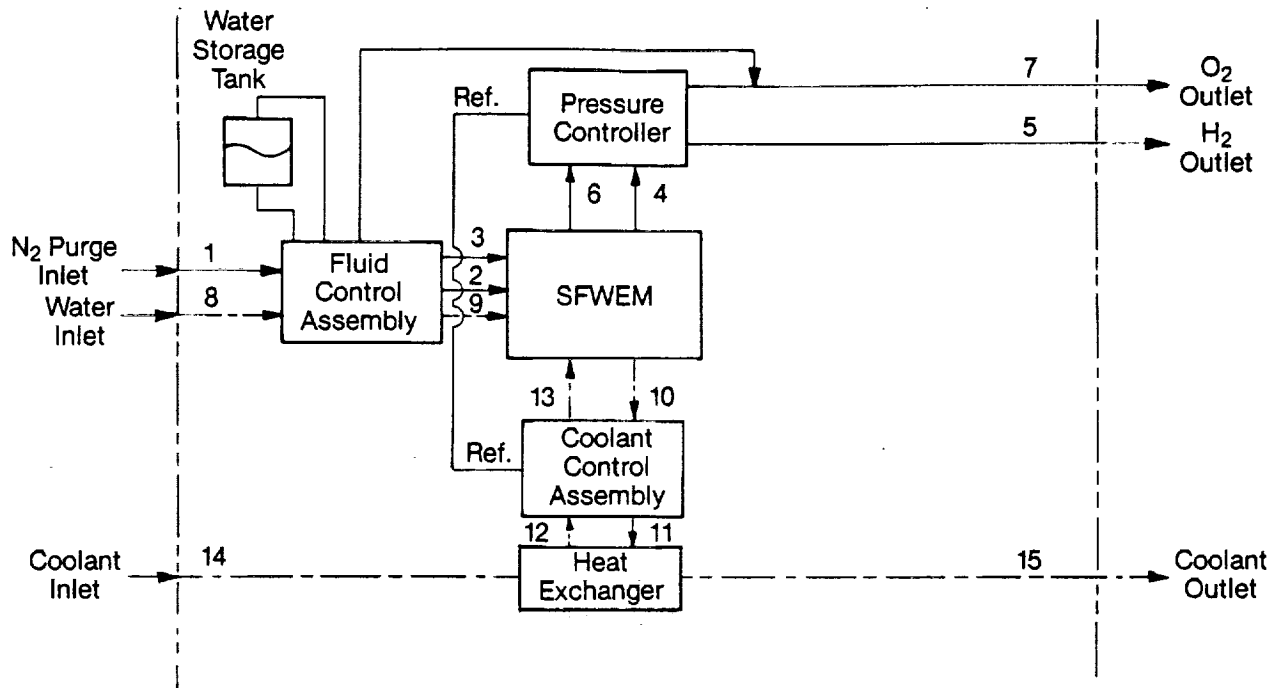

FIGURE 16 WS-6 TSA OPERATING DATA DISPLAY AND FLUID SUPPLY SIMULATORS

TABLE 5 WS-6 NOMINAL SUBSYSTEM INTERFACES^(a)

| | |
|-------------------------------------|--|
| Product O ₂ | |
| Pressure, psia | 185/300 |
| Temperature, F | Ambient |
| Flow Rate, lb/d | 14.2 |
| Dew Point Max., F | 65 |
| Product H ₂ | |
| Pressure, psia | 185/300 |
| Temperature, F | Ambient |
| Flow Rate, lb/d | 1.8 |
| Dew Point Max., F | 65 |
| Water Feed | |
| Pressure, psia | 25 |
| Temperature, F | Ambient |
| Flow Rate, lb/d | 16.0 |
| Quality | Filtered with Activated Carbon and Saturated with Air at 14.7 psia |
| Purge Gas | |
| Type | Nitrogen |
| Pressure, psia | 305 |
| Temperature, F | Ambient |
| Flow Rate (during purge only), lb/d | 1.5 |
| Duration, min | Variable (or Continuous) |
| Liquid Coolant (from and to) | |
| Type | Water |
| Supply Pressure, psia | 25 |
| Pressure Drop, psid | 2 |
| Temperature, F | |
| To | 70 |
| From | 72 |
| Flow Rate, lb/h | 153 |

(a) Mechanical/Electrochemical hardware only at the Nominal Point: 150 ASF, 180 F, 185/300 psia.



| Parameter | Location | | | | | | |
|---|----------|-------|-------|-------|-------|-------|-------|
| | 1 | 2(a) | 3(b) | 4(c) | 5 | 6 | 7 |
| Temperature, F | 70.0 | 180.0 | 180.0 | 180.0 | 70.0 | 180.0 | 70.0 |
| Pressure, psia | 305.0 | 302.0 | 304.0 | 302.0 | 14.7 | 304.0 | 14.7 |
| Volumetric Flow, l/hr | 0 | 0 | 0 | 23.8 | 405.0 | 11.9 | 202.0 |
| Total Mass Flow lb/day | 0 | 0 | 0 | 2.2 | 2.2 | 14.5 | 14.5 |
| N ₂ Mass Flow, lb/day | 0 | 0 | 0 | 0 | 0 | 0 | 0 |
| O ₂ Mass Flow, lb/day | - | - | 0 | - | - | 14.20 | 14.20 |
| H ₂ Mass Flow, lb/day | - | 0 | - | 1.78 | 1.78 | - | - |
| H ₂ O Mass Flow, lb/day | - | - | - | 0.53 | 0.53 | 0.29 | 0.29 |
| N ₂ Partial Pressure, psia | 305.0 | 0 | 0 | 0 | 0 | 0 | 0 |
| O ₂ Partial Pressure, psia | - | - | 299.0 | - | - | 300.3 | 14.5 |
| H ₂ Partial Pressure, psia | - | 297.3 | - | 297.1 | 14.5 | - | - |
| H ₂ O Partial Pressure, psia | - | 4.7 | 5.0 | 4.9 | 0.2 | 3.7 | 0.2 |
| Dew Pt. Temp, F | <20 | 141.0 | 141.0 | 141.0 | 65.0 | 141.0 | 65.0 |
| Relative Humidity, % | <5 | 77.5 | 77.5 | 77.5 | 66.2 | 77.5 | 66.2 |

| Parameter | Location | | | | | | | |
|-----------------------|----------|-------|----------|---------|---------|----------|---------|---------|
| | 8 | 9 | 10 | 11 | 12 | 13 | 14 | 15 |
| Temperature, F | 70.0 | 70.0 | 180.0 | 180.0 | 170.0 | 170.0 | 70.0 | 72.0 |
| Pressure, psia | 25.0 | 300.0 | 300.0 | 313.0 | 311.0 | 310.0 | 25.0 | 23.0 |
| Volumetric Flow, l/hr | 0.3 | 0.3 | 279.0 | 160.0 | 160.0 | 279.0 | 70.0 | 70.0 |
| Total Mass Flow, lb/d | 15.84 | 15.84 | 14,736.0 | 8,400.0 | 8,400.0 | 14,736.0 | 3,672.0 | 3,672.0 |

- (a) Stream 2 is used only for N₂ purging of the H₂ gas stream. After the WS-6 has reached a continuous operating steady-state, stream 2 will eventually be the composite of stream 4. During and immediately following N₂ purging, stream 2 will be primarily N₂.
- (b) Stream 3 is used only for N₂ purging of the O₂ gas stream. After the WS-6 has reached a continuous operating steady-state, stream 3 will eventually be the composition of stream 6. During and immediately following N₂ purging, stream 3 will be primarily N₂.
- (c) Operating Conditions: 150 ASF, 180 F, 300 psia.

FIGURE I7 WS-6 SFE MASS AND ENERGY BALANCE

WS-6 Mechanical/Electrochemical Assembly

In addition to the six-cell 1.0 ft² module discussed previously, the WS-6 Mechanical/Electrochemical Assembly (M/E A) consists of three major and two minor mechanical components discussed below. Optimized weight, volume and power requirements were imposed on the WS-6 as summarized in Table 6. Total weight of the WS-6 is 183.4 lb with total "envelope" volume of 6.98 ft³. Power consumption for the WS-6 at the subsystem level is 1,717 W (both DC and AC) with only 385 watts of waste heat rejected.

The WS-6 subsystem which is shown in Figure 18 operates as follows.

The product O₂ and H₂ is generated in the module. From the module the product gases pass through the Three-Fluids Pressure Controller (3-FPC) which monitors and adjusts subsystem pressures and maintains proper overall and differential pressures between the O₂, H₂ and water feed cavities of the module. A Coolant Control Assembly (CCA) supplies liquid coolant to the module for the removal of product waste heat. The heat is transferred from the subsystem by way of the liquid/liquid heat exchanger (HX1). The water is supplied to the module by a pressurized, cyclically filled water supply tank (TK1). During the fill cycle, the water tank is isolated from the module and depressurized. The subsystem has the capability for nitrogen (N₂) purging both the O₂ and H₂ cavities of the module and for repressurizing of the water feed tank after the water tank fill cycle accomplished via the Fluids Control Assembly (FCA).

WS-6 CONTROL/MONITOR INSTRUMENTATION

The developmental C/M I with operator/subsystem interface panel is contained in a separate enclosure. The function of the C/M I is to provide: (1) automatic mode and mode transition control, (2) automatic shutdown provision for self-protection, (3) provisions for monitoring subsystem parameters and (4) provisions for interfacing with ground test instrumentation including the Data Acquisition and Reduction System (DARS).

In event of a power failure, an Uninterruptible Power Supply (UPS) will allow the subsystem to be configured into a safe operating mode. Figure 19 shows the WS-6 with TSA, UPS and C/M I.

The WS-6 has four different operating modes as illustrated in Figure 20 and defined in Table 7. Nine different transitions between the operating modes are permissible and programmed into the C/M I. The nine mode transitions are identified by arrows between the boxes shown in Figure 20.

Test Program WS-6 SN01

The WS-6 test program consisted of checkout testing, shakedown testing, parametric testing and endurance testing. The testing included a total of 695 hr and was conducted according to the formal WS-6 Test Plan.

Checkout Testing

Checkout testing of the WS-6 was performed initially. The checkout testing consisted of all sensor calibrations, mechanical and electrical integrity

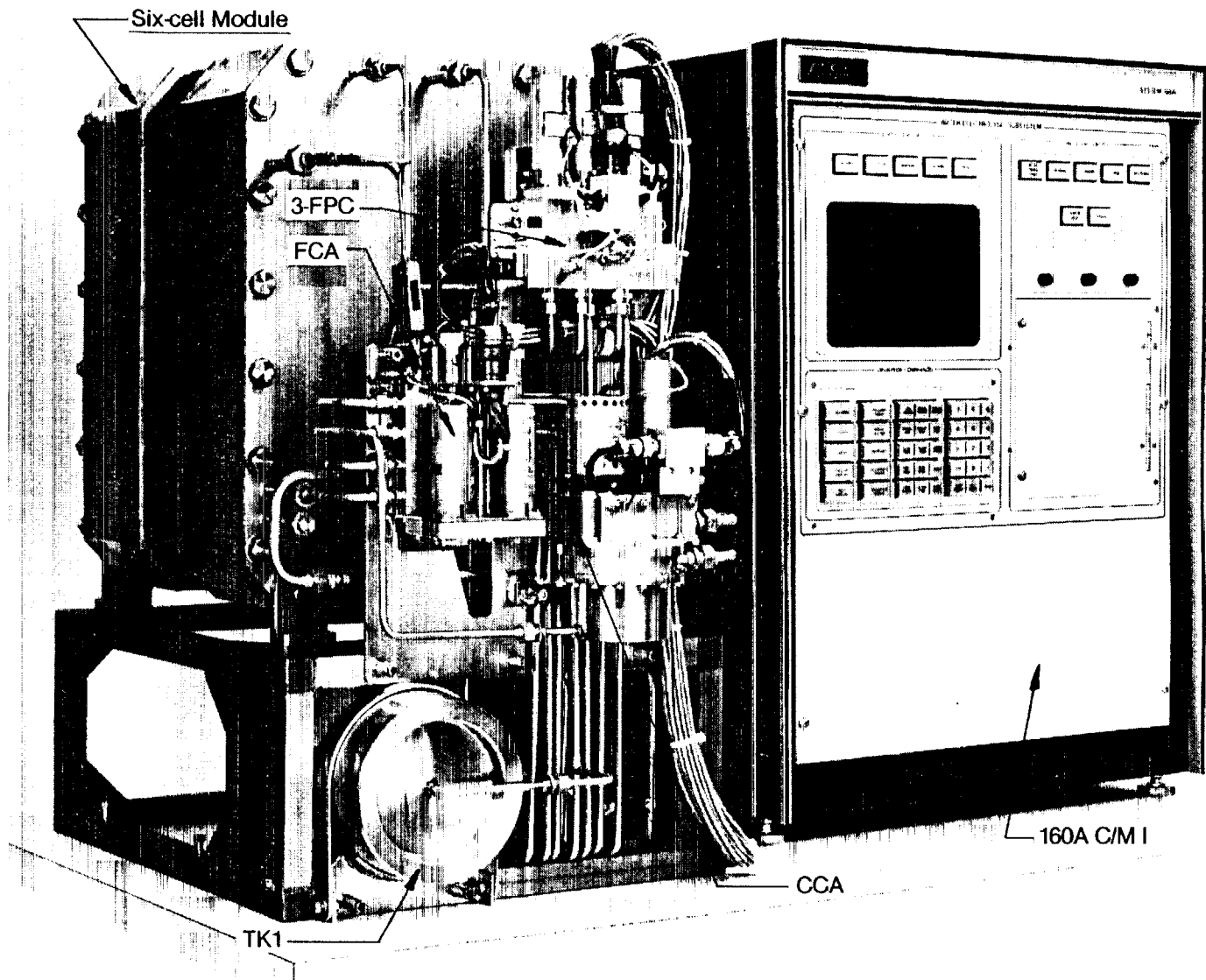

FIGURE 18 WS-6 MECHANICAL/ELECTROCHEMICAL ASSEMBLY WITH C/M I

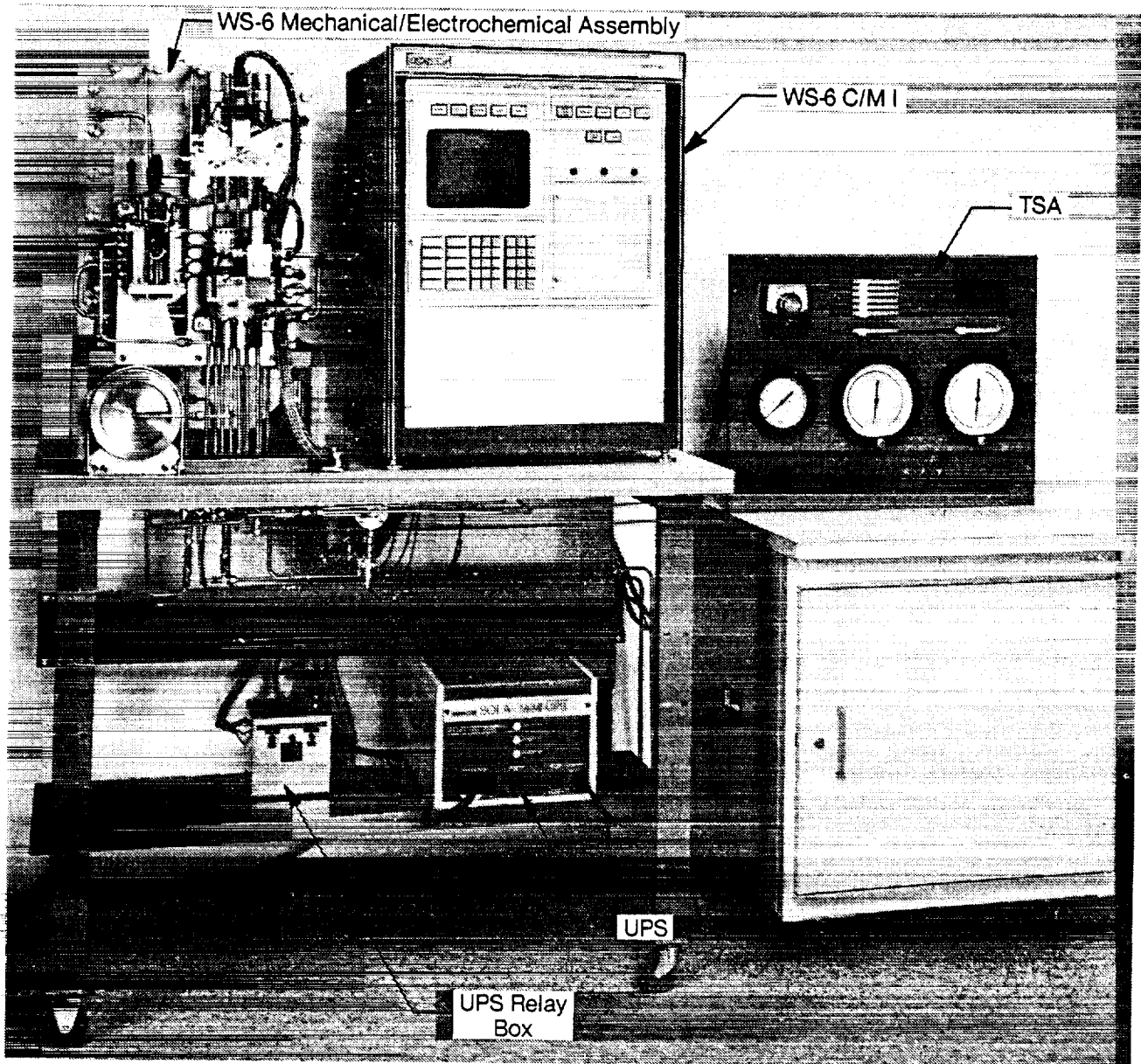
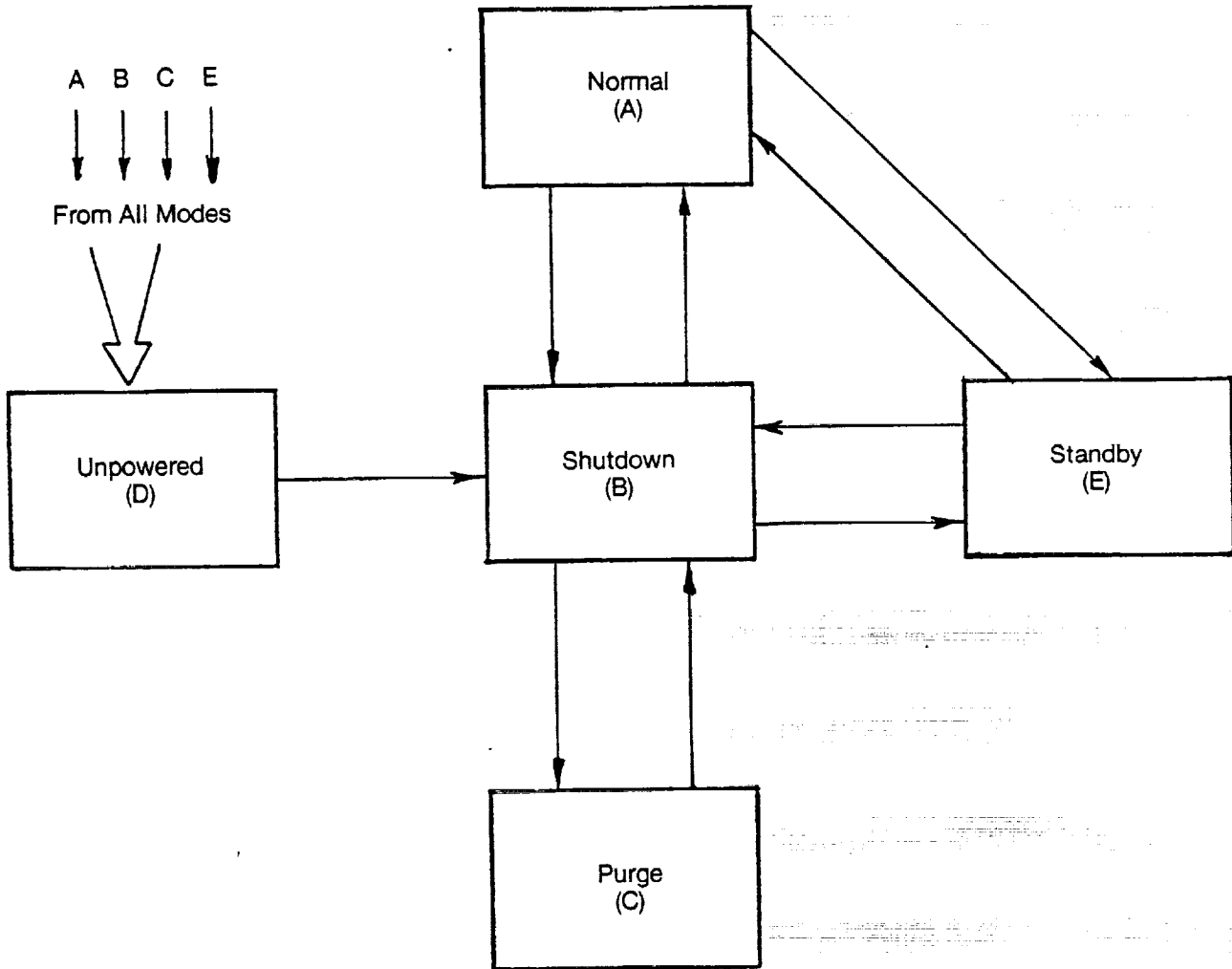

FIGURE 19 WS-6 SUBSYSTEM WITH TEST SUPPORT ACCESSORIES (TSA) AND UNINTERRUPTABLE POWER SUPPLY (UPS)



- 5 Modes
- 4 Operating Modes
- 13 Mode Transitions
- 9 Programmable, Allowed Mode Transitions

FIGURE 20 WS-6 MODES AND ALLOWABLE MODE TRANSITIONS

TABLE 7 WS-6 OPERATING MODES AND UNPOWERED MODE DEFINITIONS

| Mode (Code) | Definition |
|--------------|---|
| Shutdown (B) | <p>The WS-6 is not generating O₂ or H₂. Module current is zero and none of the actuators are energized. The subsystem is powered and all sensors are working. The Shutdown Mode is called for by</p> <ul style="list-style-type: none"> ● Manual actuation ● High WEM temperature ● High subsystem pressure ● Low subsystem pressure ● High cell voltage ● High H₂/O₂ pressure differential ● Low H₂/O₂ pressure differential ● High H₂/water pressure differential ● Low H₂/water pressure differential ● Low water tank pressure differential ● Low pressure controller temperature ● High pressure controller temperature ● High O₂ outlet temperature ● Power On Reset (POR) from Unpowered Mode (D) ● Mode transition from Shutdown Mode (B) to Normal (A) Standby (E), or Purge (C) was not successful. All transitions to the Shutdown Mode (except Power On Reset) include a timed purge sequence as part of the mode transition sequence |
| Normal (A) | <p>The WS-6 is performing its function of generating O₂ and H₂ at the design rate. The Normal Mode is called for by</p> <ul style="list-style-type: none"> ● Manual actuation |
| Standby (E) | <p>The WS-6 is ready to generate O₂ and H₂. The subsystem is powered at operating pressure and maximum temperature possible (but less than setpoint) and the module current is off. The Standby Mode is called for by</p> <ul style="list-style-type: none"> ● Manual actuation |
| Purge (C) | <p>The WS-6 is being purged with N₂ through the gas lines and cell compartments. The module current is off, the subsystem is at low pressure (1.5 psig) and at ambient temperature. This is a continuous purge until a new mode is called for. The Purge Mode is called for by</p> <ul style="list-style-type: none"> ● Manual actuation |

continued-

Table 7 - continued

| Mode (Code) | Definition |
|---------------|--|
| Unpowered (D) | <p>No electrical power is applied to the WS-6. The Unpowered Mode is called for by</p> <ul style="list-style-type: none"> ● Manual actuation (circuit breaker in TSA) ● Electrical power failure ● FCA position error <p>FCA valves V4 and V5 are open to allow for possible N₂ purging. The extent of N₂ purging during the unpowered mode is determined by the TSA control over the N₂ purge source.</p> |
| | <ul style="list-style-type: none"> ● CONTINUOUS OPERATION |
| | <p>The subsystem is in the Normal Mode with constant current operation.^(a) The WS-6 is generating O₂ and H₂ at the design rate.</p> |
| | <ul style="list-style-type: none"> ● CYCLIC OPERATION |
| | <p>The subsystem is operating in the cyclic Normal Mode. Current is applied to the module during the lighted portions of a low earth orbit (54 min) when the solar arrays supply power to the spacecraft. During the dark portion of low earth orbit (36 min) the WS-6 is transferred to the Standby Mode^(b) where it operates with trickle current to maintain differential pressures.</p> |

(a) The green Normal Mode light and green Continuous duty cycle light will be on at all times.

(b) The green Standby Mode light and cyclic duty cycle light will be on.

checks and verification that components and subassemblies were correctly integrated. Main aspects of the checkout testing include:

3-FPC - The 3-FPC was continually exercised during transitions from Shutdown to Normal to perform the function of building system pressure to the desired level of 300 psig. Normal to Shutdown transitions also checked the function of the 3-FPC during depressurizations.

CCA - The pumping action of the CCA was verified along with the control of the diverter valve between module and heat exchanger settings.

FCA - The valve actions along with flow rates were verified.

Power Supply - The 500A Sorensen power supply which was furnished by NASA LeRC was checked out when integrated with the 100 Series C/M I. Current control circuits, specifically designed for the interface between the power supply and C/M I were also checked.

Calibration data on all voltage meters, current meters, temperature sensors, pressure sensors and valve position indicators were recorded in appropriate test log books.

Shakedown Test

The WS-6 Shakedown Test was completed with 24 hr of continuous uninterrupted operation at 180 psia, 150 F and 150 ASF. No major problems were encountered with operation of subsystem components during this test. The average cell voltage for the six-cell module was 1.70 V which falls in the typical advanced electrode performance band for 150 F.

Parametric Test - Pressure

The purpose of the pressure parametric testing was to explore the subsystem response to changes in electrolysis module pressure over the range of 165-250 psig. A constant current of 150 A (150 ASF) and temperature of 150 F were maintained throughout the 130 hr test. Figure 21 shows cell voltage performance as a function of operating time and operating pressure. The initial 45 hr were obtained at 165 psig. Pressure was incrementally stepped up to 250 psig over the next 30 hr with minimal increase in average cell voltage. The remaining 55 hr testing were completed at 250 psig. A 30 mV increase in average cell voltage over the 165 to 250 psig pressure range was due to loss of compression in the electrode area of the cells. Loss of compression was due to internal cell stack-up. The 0.020 in thick polysulfone compression frame was not providing adequate support to the edge of the electrodes at the higher operating pressures. To provide additional support at the edge of the electrodes the compression frames were reinforced with a band of 0.003 in thick teflon. This modification has been incorporated into the module for further testing.

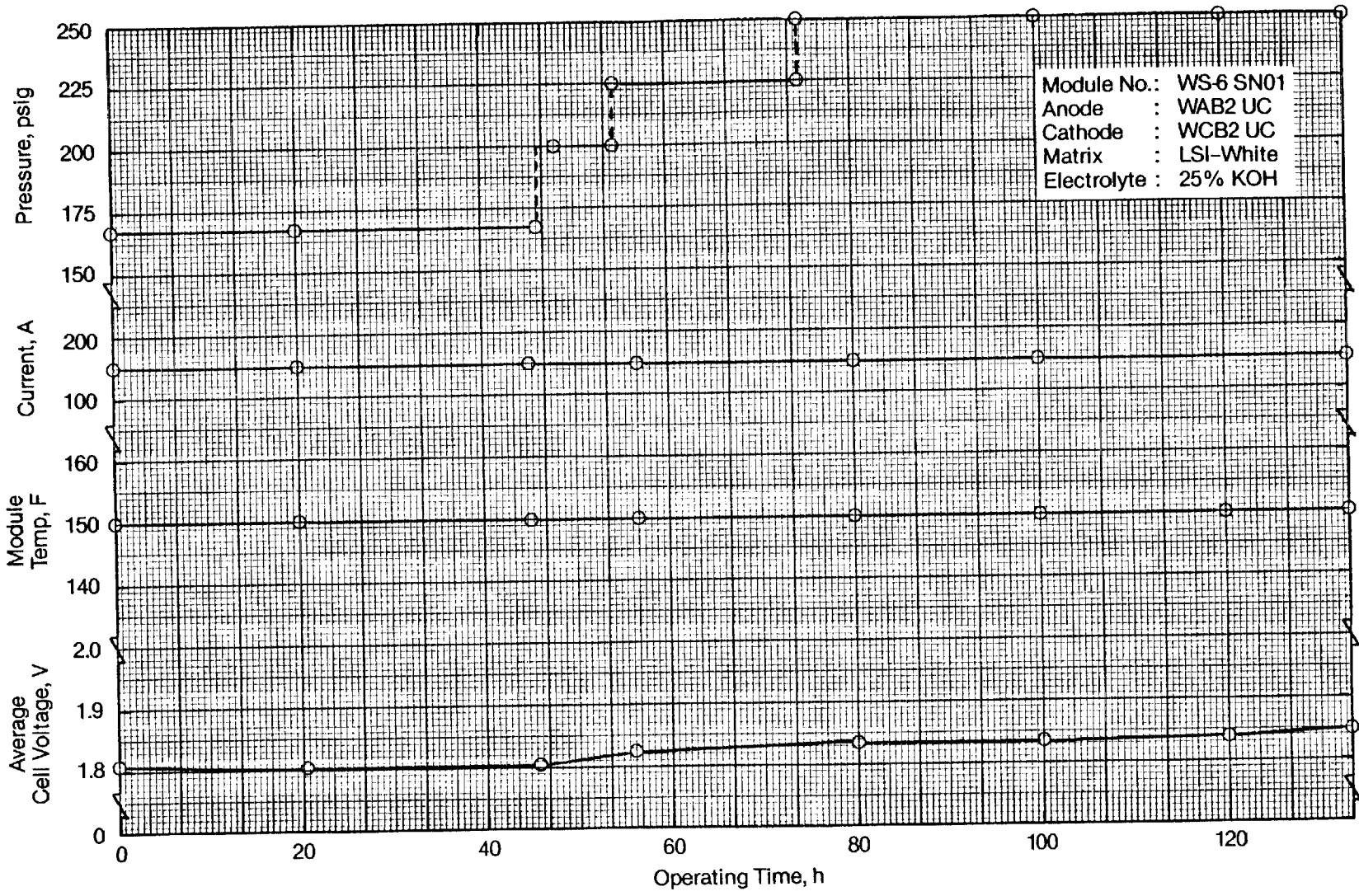

FIGURE 21 CELL PERFORMANCE VERSUS TIME, WS-6 PARAMETRIC TEST

Loss of compression is also caused by the "bowing" in the center of the module end plates. Prior to testing the module in the WS-6, center-to-edge deflection measurements had been taken in pressure increments of 50 psig up to 300 psig (see Table 3). Deflection of the fluids end plate at 250 psig was measured at 0.007 in at the center while deflection of the structural end plate at 250 psig was measured at 0.009 in at the center. The combined deflection of the two end plates is within design specification and would result in negligible compression loss or voltage impact in the cells.

Parametric Test - Temperature

The objective of the temperature parametric testing was to explore the subsystem response to changes in electrolysis module temperature over the range of 150 to 180 F. A constant current of 150 A (150 ASF) and pressure of 165 psig were maintained throughout the test. Cell voltage of a typical cell versus cell temperature is shown in Figure 22. Test results show a 3.6 mV decrease in cell voltage for a 1 F increase in cell temperature over the 150 to 180 F temperature range. Figure 22 shows a typical cell voltage of 1.66 V at 180 F and 150 A. This voltage is well within the typical advanced electrode performance band at 180 F.

Endurance Test

The objective of the WS-6 endurance test was to demonstrate WS-6 operation over time at nominal operating conditions. A total of 695 hr of testing was accumulated on the WS-6 throughout the initial portion of the test program reported herein at a constant current of 150 A. Figure 23 depicts cell performance versus operating time for all WS-6 testing completed to date. Outside of the 130 hr pressure parametric test, the remaining test data was obtained at an operating pressure of 165 psig. After 475 hr of testing at the nominal operating temperature of 150 F, the temperature was raised to 180 F for the remainder of the test. This temperature increase is in concert with projected Space Station operation supported by the results of the temperature parametric test which showed marked improvement in cell voltage at 180 F. The average cell voltage at 150 ASF, 180 F and 165 psig was 1.69 V when testing was discontinued. The performance lies within the typical advanced electrode performance band.

System pressure was maintained at 165 psig. It was found that the specially molded O-rings used in the modules were taking on a permanent set after 300 hr of operation which results in the module being unable to maintain system pressure above 200 psig. The molded O-ring material did not meet the specifications required by the module design or those specified by the vendor. All standard catalog product O-rings maintain their resiliency. While continuing to operate at 165 psig with existing molded O-rings, O-ring materials acceptance criteria was being evaluated for use in the module. Material that passes these standards will show better resiliency and exhibit minimal permanent set.

DEVELOPMENT OF HIGH PRESSURE WATER ELECTROLYSIS MODULE ENDURANCE TEST STAND

A test stand was designed and fabricated to allow testing of multicell 0.1 ft² modules at elevated pressures. Nominal operating ranges for this test stand

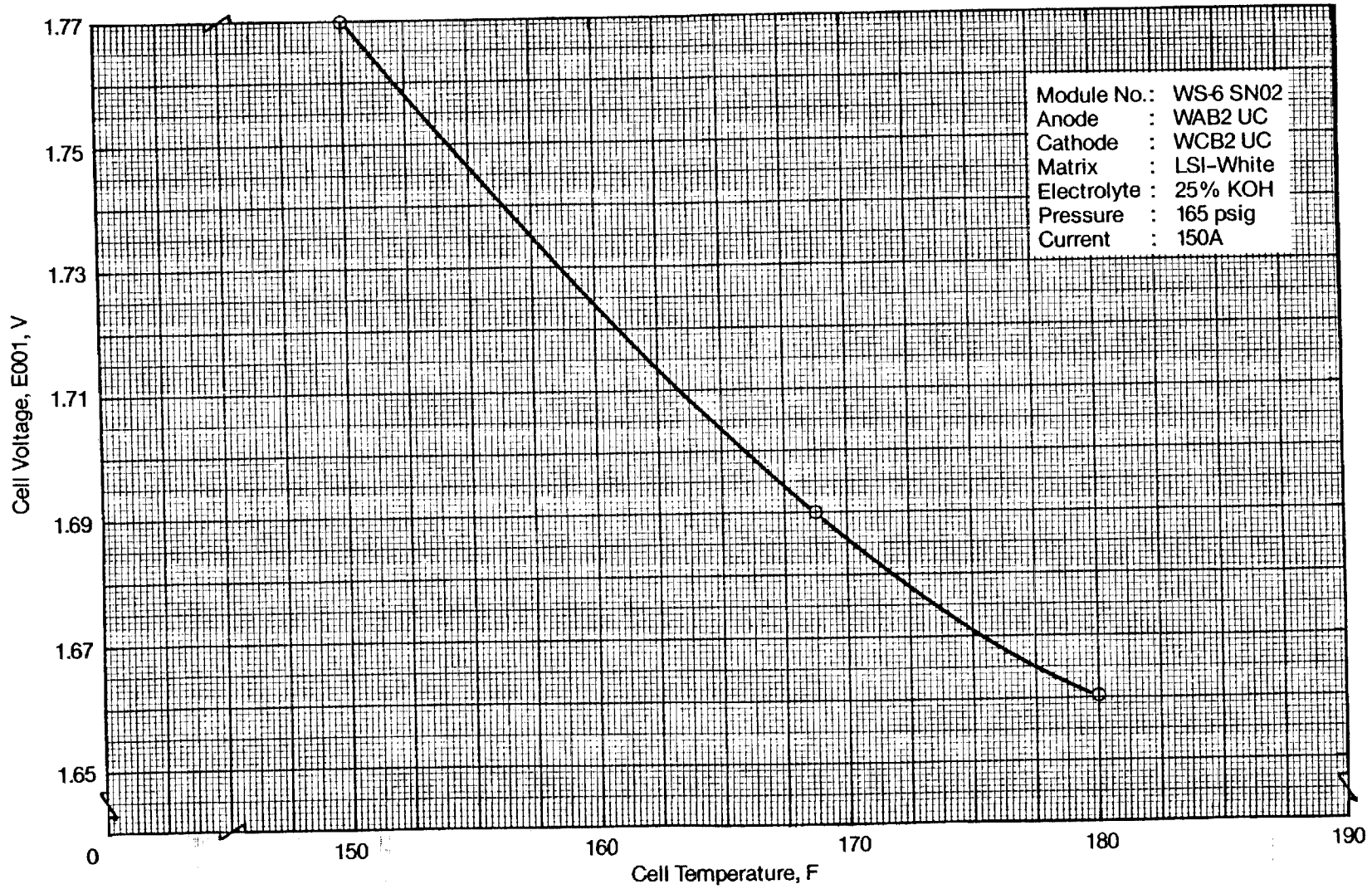

FIGURE 22 CELL VOLTAGE VERSUS CELL TEMPERATURE, WS-6 PARAMETRIC TEST

47

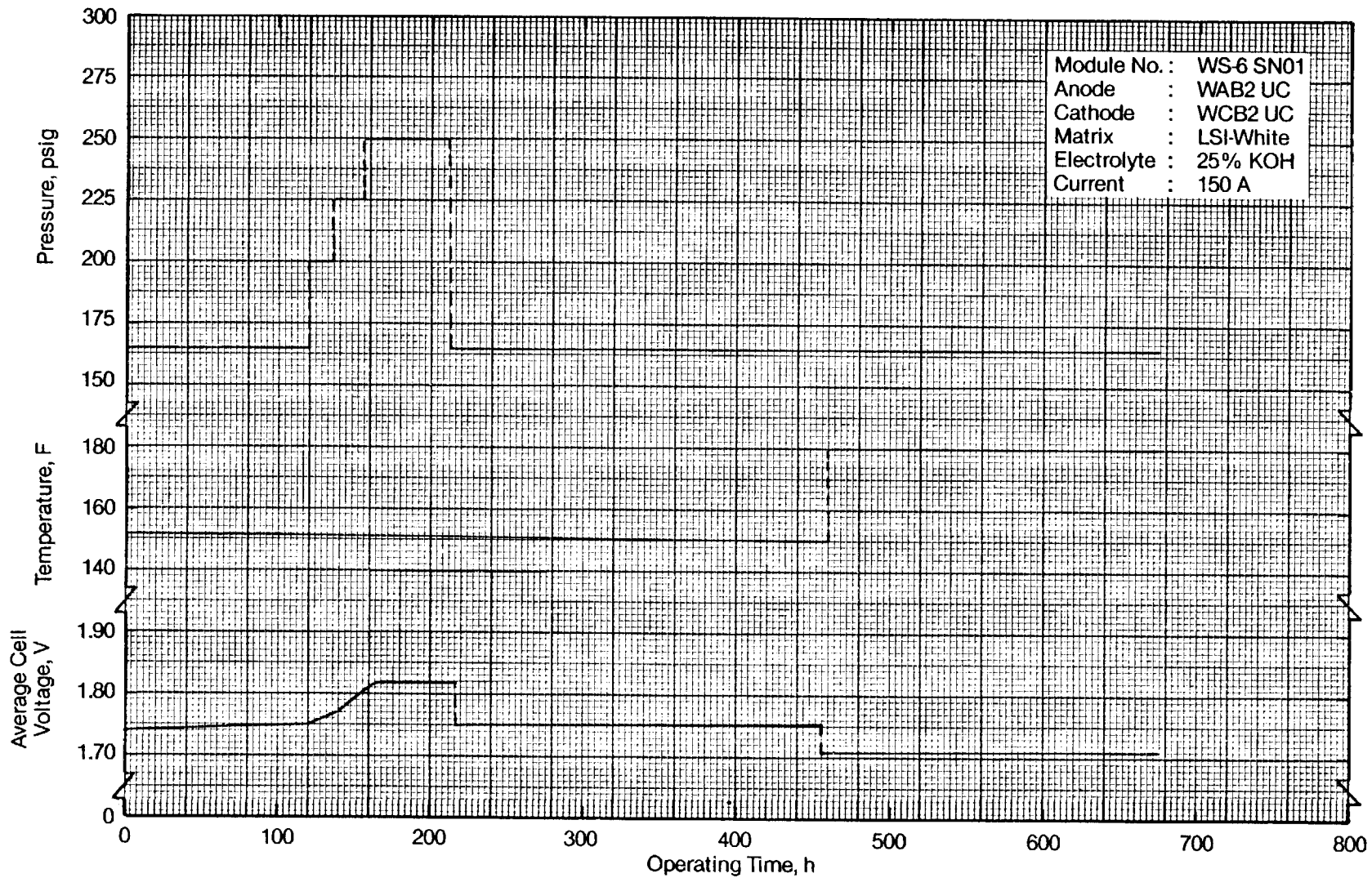

FIGURE 23 CELL PERFORMANCE VERSUS TIME, WS-6 ENDURANCE TEST

are: pressure, 120 to 300 psig; temperature, 70 to 200 F; and current, 0 to 50A (0 to 500 ASF). The mechanical schematic for the test stand is shown in Figure 24. The front panel and full views of the test stand are shown in Figures 25 and 26, respectively.

The test stand has one liquid circulating loop of Fluorinert FC-40 which serves as module coolant. The Fluorinert is circulated via M2. Water is statically fed from the water storage tank (WT2) directly to the feed water cavities of the module. Product H_2 and O_2 are vented to ambient through back pressure regulators PR1 and PR2, respectively. Pressure regulator PR3 can be adjusted to build up to and maintain the desired system operating pressure. N_2 purge is automatically introduced into the test stand in the event of a shutdown through solenoid valves V1 and V2. Varying amounts of water vapor are removed from the module with the product gases depending on operating conditions. In order to maintain operating flexibility for parametric testing, condensers C1 and C2 and liquid traps TR1 and TR2 are necessary to remove the water from the gas streams. Test stand electrical controls are identical to those discussed previously. (6)

ENDURANCE TESTING OF 0.1 FT² WATER ELECTROLYSIS CELLS AND MODULES

The Static Water Electrolysis Cell (SWEC) testing is designed to carry out additional phases of an on-going assessment of the state of alkaline water electrolysis technology and its capability as part of a RFCS in a large orbiting power plant. The specific objective of the SWEC testing is to demonstrate the operational readiness of the concept and cell hardware while accumulating a data base of parametric and endurance test data upon which to assess the potential of the alkaline electrolyzer. This is being accomplished by:

1. Endurance testing four 0.1 ft² alkaline water electrolysis cells at ambient pressure for a total of 116,522 cell-hours. Two of these SWECs are operating in the cyclic current mode with current "on" for 54 minutes and "off" for 36 minutes.
2. Endurance testing a 0.1 ft² SWEC at high pressure (200 psig) for a total of 6,900 hours.
3. Endurance testing a 0.1 ft² SWEC at high pressure (200 psig) as part of a six-cell module for 2,450 hours. This SWEC incorporated the 0.1 ft² unitized core which is similar to the 1.0 ft² unitized core discussed previously.
4. Characterizing each of the above cell's performance with voltage versus current density data.

The purpose of the endurance test is to continuously operate the cells at constant sets of condition to observe any departures from initial cell performance (cell voltage) levels. The materials of construction for the SFE cells are being evaluated in the endurance tests. A complete summary of all endurance testing is shown in Table 8.

HIGH PRESSURE WATER ELECTROLYSIS MODULE (WEM) ENDURANCE TEST

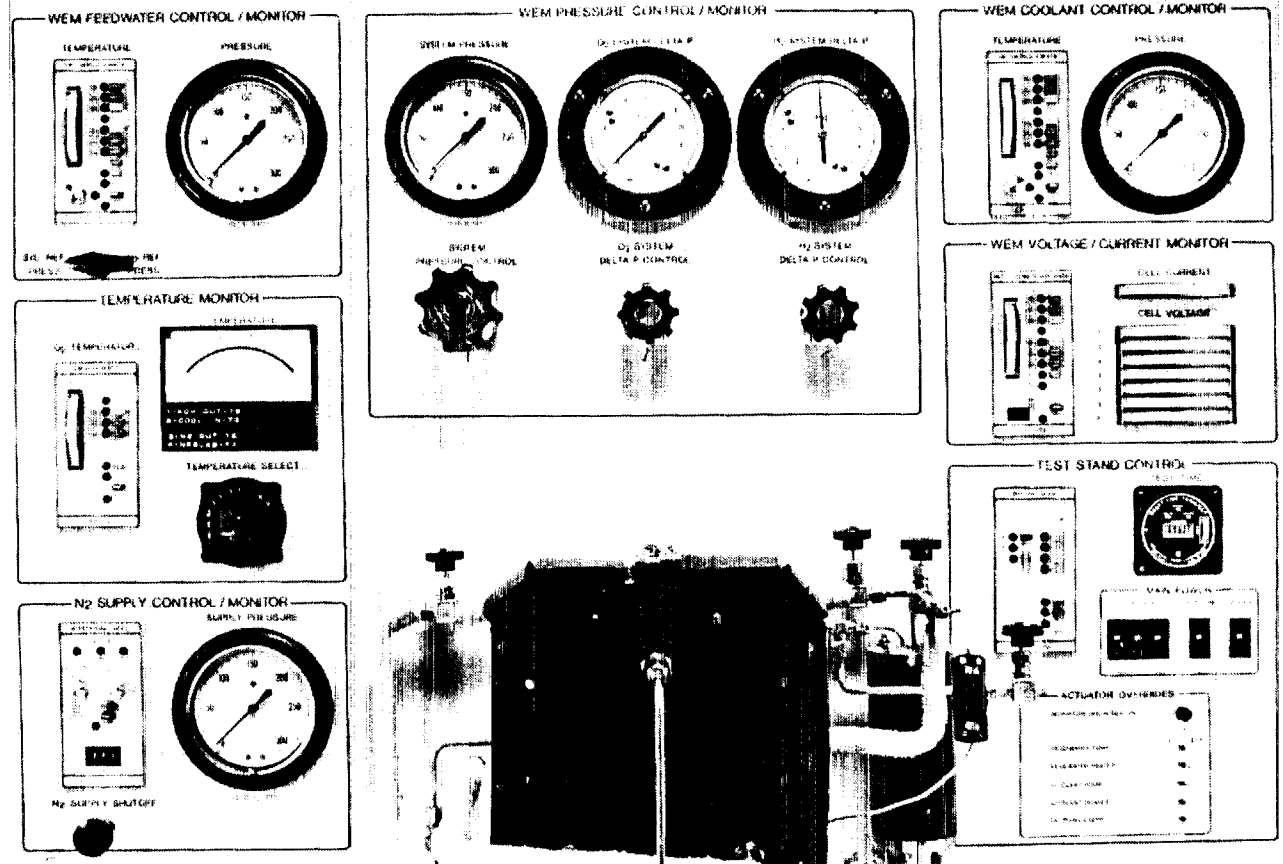

50

FIGURE 25 FRONT PANEL VIEW - HIGH PRESSURE TEST STAND

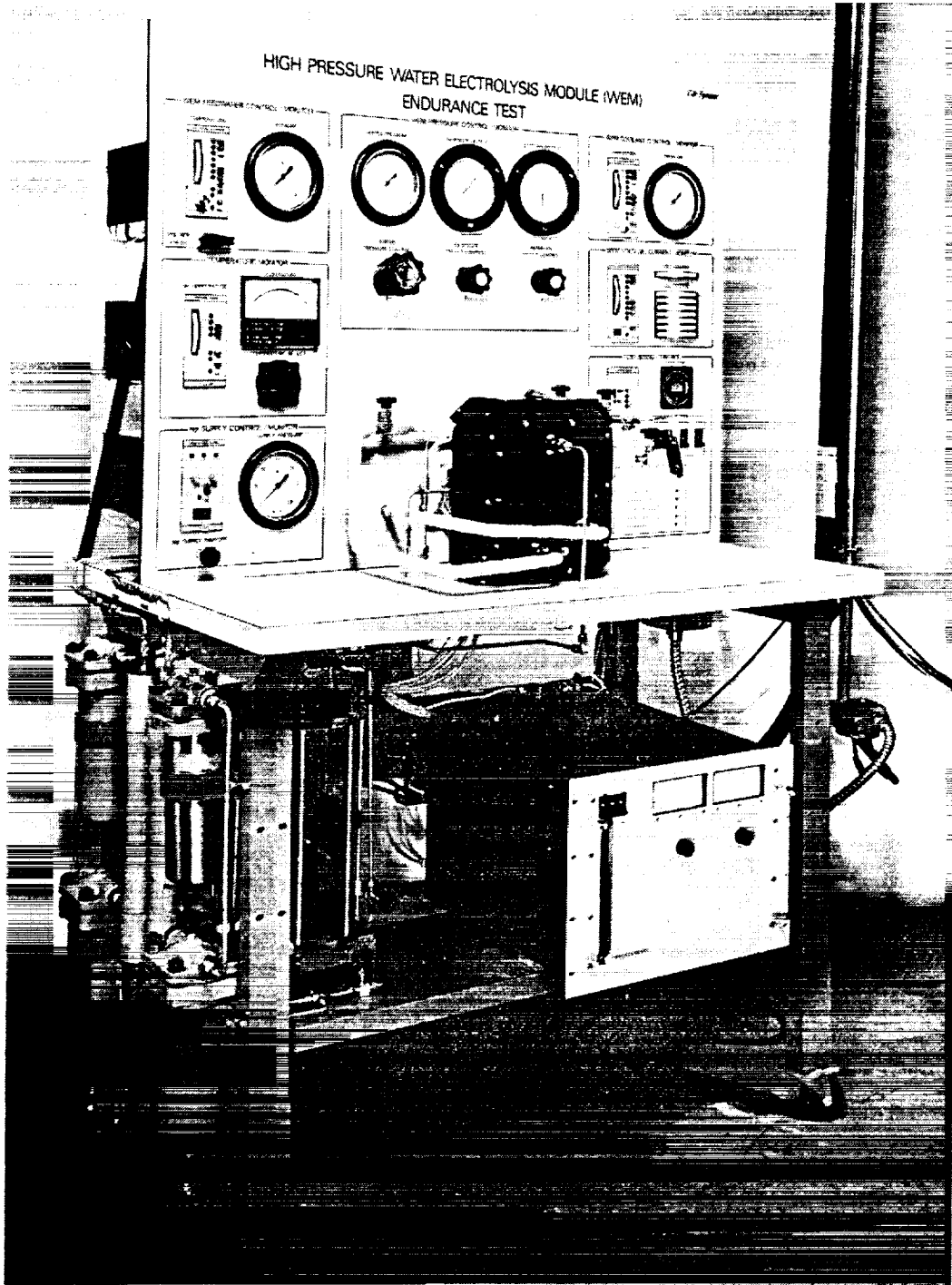

FIGURE 26 FULL VIEW - HIGH PRESSURE TEST STAND

Table 8 STATIC FEED WATER ELECTROLYSIS ENDURANCE TEST SUMMARY

| <u>Cell No.</u> | <u>Electrode Type</u> | <u>Total Test Time, hr.</u> | <u>Continuous Current Test Time hr</u> | <u>Current Density ASF</u> | <u>Cyclic Current Test time hr</u> | <u>Current Density ASF</u> | <u>Total Current "On" Time, hr</u> |
|---------------------|-----------------------|-----------------------------|--|----------------------------|------------------------------------|----------------------------|------------------------------------|
| 105A | Advanced | 16,856 | 8,578 8,278 | 300 150 | - | - | 16,856 |
| 105B | Advanced | 34,607 | 6,300 | 150 | 28,307 | 150 | 23,285 |
| 105C | Super | 32,374 | 11,313 21,061 | 300 150 | - | - | 32,374 |
| 105D | Super | 32,685 | 5,260 | 150 | 27,425 | 150 | 21,715 |
| 127-SWEC | Advanced | 6,900 | 6,900 | 150 | - | - | 6,900 |
| 127 Six-Cell Module | Super Unitized Core | 2,450 | 2,450 | 150 | - | - | 2,450 |
| Total | - | 125,872 | 70,140 | - | 55,732 | - | 103,580 |

52

Single Cell Endurance Testing at Ambient Pressure

Under this program, four SWECs are being endurance tested on SWEC Test Stands under various operating conditions. Detailed descriptions of the SWEC mechanical design and the SWEC Test Stand Design have been discussed previously. ⁽⁶⁾ The following subsections describe each of the ambient pressure tests.

SWEC Endurance Test 105A

SWEC 105A with an advanced anode has completed 16,856 hours of operation at 180 F and ambient pressure. The initial 8,278 hours of testing were completed at a continuous current of 15A (150 ASF) and the remaining 8,578 hour were completed at a continuous current of 30A (300 ASF). The performance versus time of SWEC 105A is shown in Figure 27. At the start of testing, SWEC 105A had a cell voltage of 1.54 V at 180 F. After approximately 4,500 hour of testing, the voltage began to slowly rise. By load time 7,900 hour the voltage had risen to 1.68 V. Similar increases in cell voltage were observed in the other three ambient pressure SWECs. The cause of this increase in cell voltage was found to be deflection of the polysulfone end plates due to creep of the thermoplastic under thermal and mechanical loads. The deflection resulted in loss of electrical contact within the cells at the electrode and, therefore, higher cell voltage. At load time 7,946 hours, the polysulfone end plates were replaced with stainless steel end plates. This change resulted in a 170 mV drop in cell voltage from 1.68 to 1.51 V. The voltage remained steady at 1.51 V for 330 hour. At load time 8,278 hours, the current was increased to 30A (300 ASF). The initial voltage at 30A was 1.64 V which exceeded the performance expected of advanced electrodes. The voltage slowly increased through the remainder of the test, finally exiting from the advanced performance band at 1.82 V at load time 14,000 hour. By load time 16,850 hour the voltage had risen to 1.84 V.

SWEC 105A testing was terminated at L.T. 16,856 hour due to a test stand/operator problem causing cell damage. The cell failure was a direct result of a test stand operator-induced malfunction. The increasing cell voltage had signaled the test stand to shut down but this signal was ignored because a shutdown override had inadvertently been left on. Current continued to be applied to the SWEC. Resistance heating in the cell eventually caused damage to certain components in the SWEC. NASA LeRC and Life Systems mutually agreed to discontinue the testing of SWEC 105A.

SWEC Endurance Test 105B

SWEC 105B with an advanced anode has completed 34,607 hours of operation at 180 F and ambient pressure. The initial 6,300 hours of testing were completed at a continuous current of 15A (150 ASF). The remaining 28,307 hours of testing were completed under cyclic current conditions with current "on" for 54 minutes at 15A and current "off" for 36 minutes. Total current "on" time for both continuous and cyclic testing is 23,285 hours.

FIGURE 27 SINGLE CELL PERFORMANCE VERSUS TIME, CELL NO. 105A

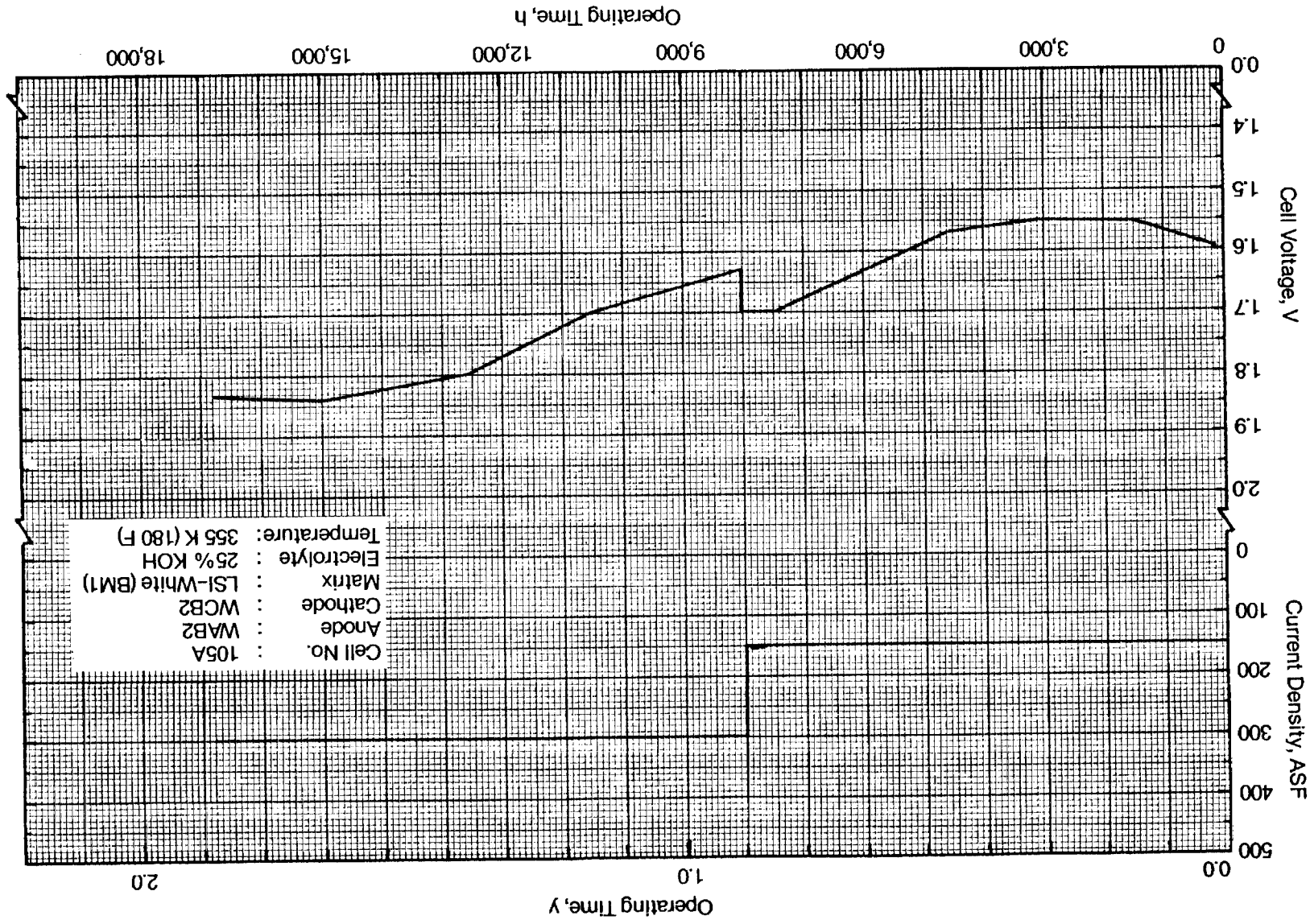

The performance versus time of 105B is shown in Figure 28. Initial cell voltage of 105B was 1.58 at 15A. 105B exhibited steady performance throughout the life of the tests with a voltage of 1.61 V after 34,600 hours. Testing of 105B is continuing at cyclic current conditions.

SWEC Endurance Test 105C

SWEC 105C with a super anode has completed 34,607 hours of operation at 180 F and ambient pressure. A total of 21,061 hours of testing was completed at a continuous current of 15A (150 ASF) and 11,313 hours of testing was completed at 30A (300 ASF). Total operating time is 32,374 hours.

The performance of 105C is shown in Figure 29. The initial 5,000 hours of testing was completed at 15A (150 ASF). A slowly rising voltage at 15A was found to be due to thermal creep in the polysulfone end plates. After 5,000 hours, stainless steel end plates were added to the cell and current was increased to 30A. After 4,000 hours at 30A, cell voltage began to slowly rise out of the normal super electrode performance band. After a cell disassembly and inspection after 13,000 hours of operation two problems were found to contribute to the rising voltage:

1. All bolts used to compress SWEC 105C were found to be loose. This loss in compression results in a higher voltage. The loss of bolt compression was found to be due to thermal creep in the bolts. To prevent loss of compression in the cell again, Bellville washers (four stacked in series) were used in place of flat washers. Bellville washers are now baseline washers for all water electrolysis cells and modules.
2. Two polypropylene support screens which supports the asbestos feed matrix in the cell had taken an unusual deformation around the support pegs of the feed water activity. This deformation resulted in some loss of internal cell compression in the electrode area of the cell.

Testing continued at 15A with steady performance for 6,500 hours. At load time 19,500 hours current was increased to 30A. Cell Voltage at 30A exhibited a steady rise over the next 4,000 hours. The rising voltage was found to be due to a very low concentration of KOH in the circulating feed water loop. The concentration of KOH in this loop should normally be 25% KOH but was found to be 12% KOH. A test stand fitting leak was the cause. Fresh 25% KOH was put back into the circulating loop and testing of 105C resumed at 15A. Testing is continuing for over 8,000 hours at 15A with voltage stabilizing at 1.59 V.

SWEC Endurance Test 105D

SWEC 105D with a super anode has completed 32,685 hours of operation at 180 F and ambient pressure. The initial 5,260 hours of testing were completed at a continuous current of 15A (150 ASF). The remaining 27,425 hours of testing

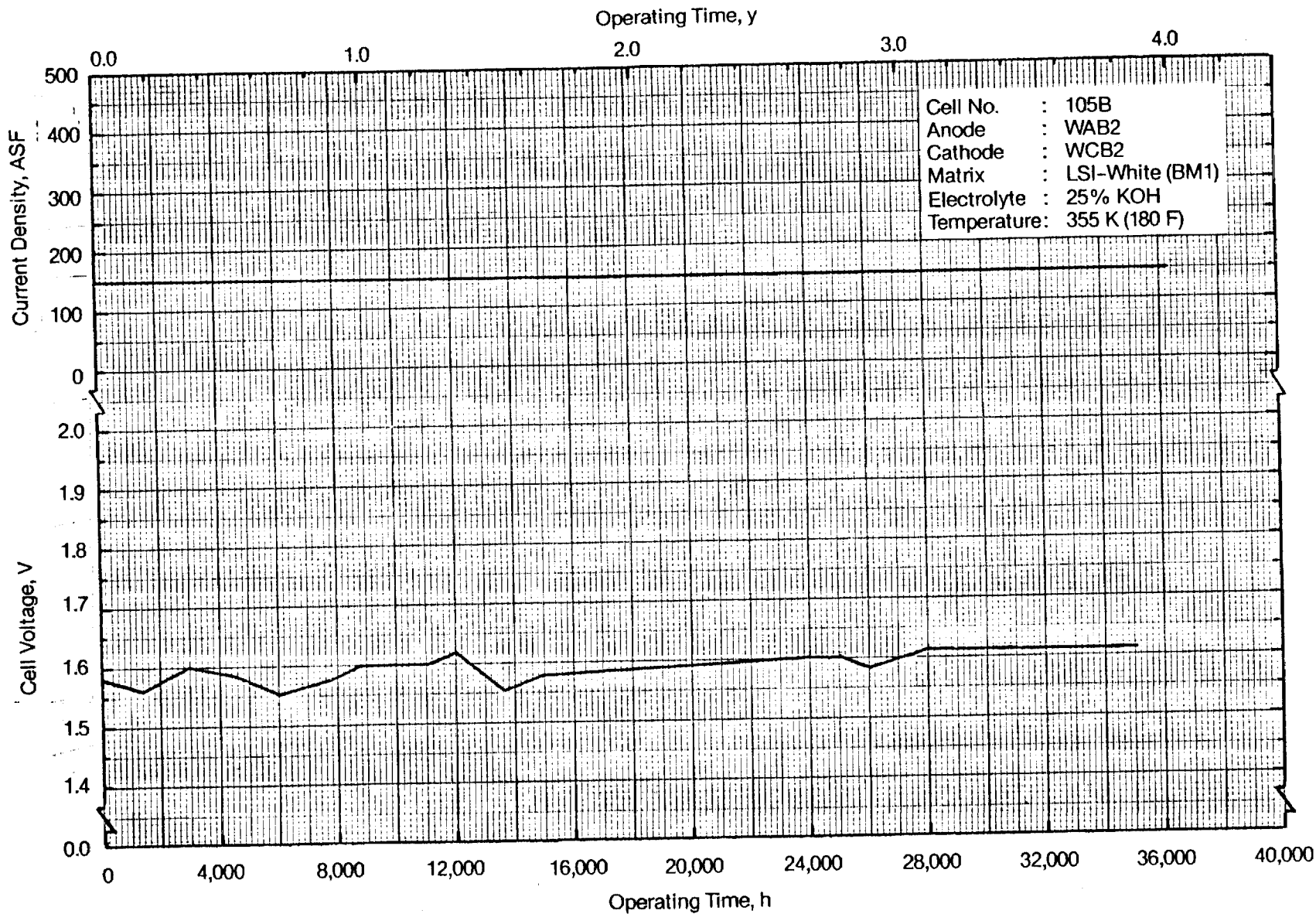

FIGURE 28 SINGLE CELL PERFORMANCE VERSUS TIME, CELL NO. 105B

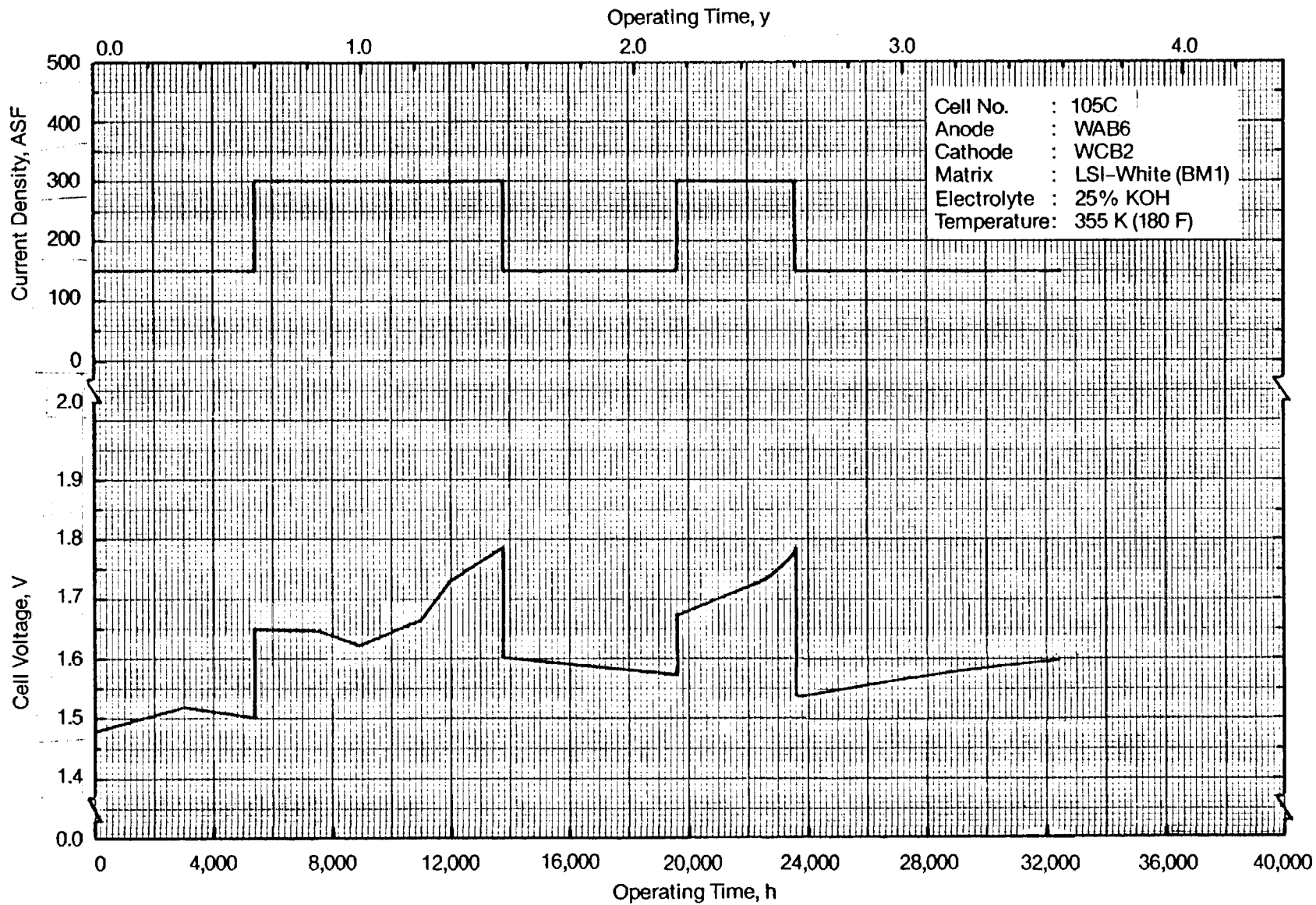

FIGURE 29 SINGLE CELL PERFORMANCE VERSUS TIME, CELL NO. 105C

were completed under cyclic current conditions with current "on" for 54 minutes at 15A and current "off" for 36 minutes. Total current "on" time for both continuous and cyclic testing is 21,715 hours.

The performance versus time of 105D is shown in Figure 30. Initial cell voltage of 105D was 1.50 V at 15A. 105D exhibited steady performance throughout the life of the test with a voltage of 1.52 V after 32,685 hours. Testing of 105D is continuing at cyclic current conditions.

0.1 Ft² High Pressure Single Cell Testing

SWEC 127 with an advanced anode has completed a total of 6,900 hours of operation at 180 F, 200 psig and 15A (150 ASF). Testing was completed on TS 127, the High Pressure Water Electrolysis Module Endurance Test Stand.

Single cell performance versus time for SWEC 127 is shown in Figure 31. Over the first 3,000 hours of operation cell voltage gradually rose from 1.62 V to a steady level of 1.67 V. Throughout testing, operating pressure remained at 200 psig and temperature remained at 180 F. Testing was terminated to allow for testing of a six-cell 0.1 ft² module at high pressure on the test stand.

Six-Cell 0.1 Ft² High Pressure Module Endurance Testing

A six-cell 0.1 ft² module was assembled with 0.1 ft² unitized cores for endurance testing on test stand 127. The module was endurance tested at a pressure of 200 psig, a temperature of 180 F and a current of 15A. The performance of the module, which has operated for 2,450 cumulative hours, is shown in Figure 32. Initial average cell voltage was 1.52 V with a slow increase in voltage observed over the first 1,500 hours of testing. Average cell voltage stabilized at 1.57 V after 2,000 hours and cell voltage has remained stable throughout the remainder of the test.

CONCLUSIONS

Based upon the work completed, the following conclusions are drawn:

1. Alkaline Static Feed Electrolysis cells and modules are capable of long-term operation without deterioration in materials at near constant performance. Endurance testing of four SFWE cells has totalled 116,522 hours with three cells approaching four years of operation. A typical voltage decay of only 0.84 μ V/hr has been experienced over 35,000 hr of operation for a single 0.1 ft² cell.
2. A weight optimized 1.0 ft² cell and module has been successfully designed. The main objective of the design was to significantly reduce module weight. This objective was met by reducing the six-cell 1.0 ft² module weight by 61% from the weight based on the initial 1.0 ft² cell design.
3. Two 1.0 ft² six-cell modules were fabricated and tested. A total of 695 hr of parametric and endurance testing has been accumulated on

65

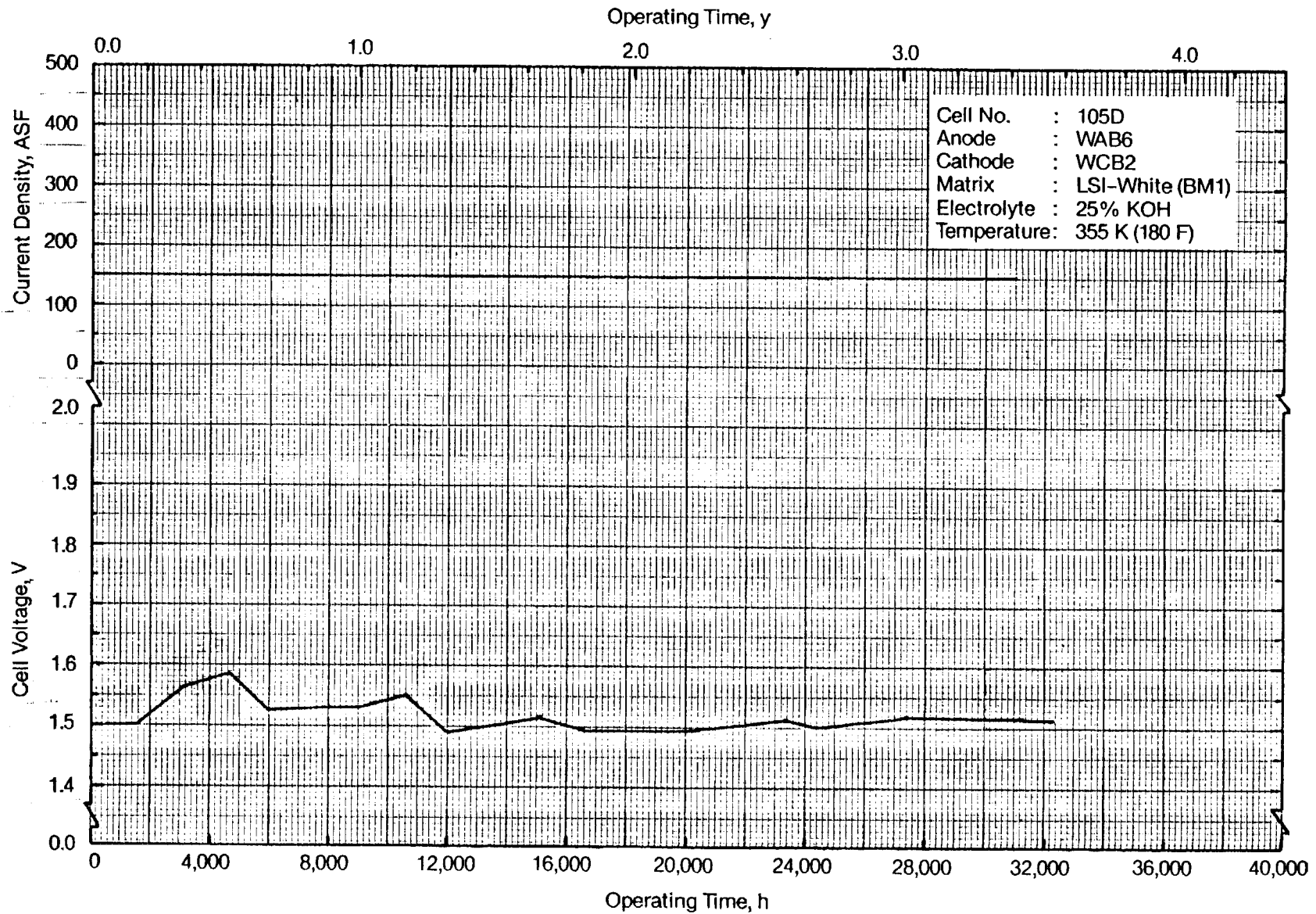

FIGURE 30 SINGLE CELL PERFORMANCE VERSUS TIME, CELL NO. 105D

09

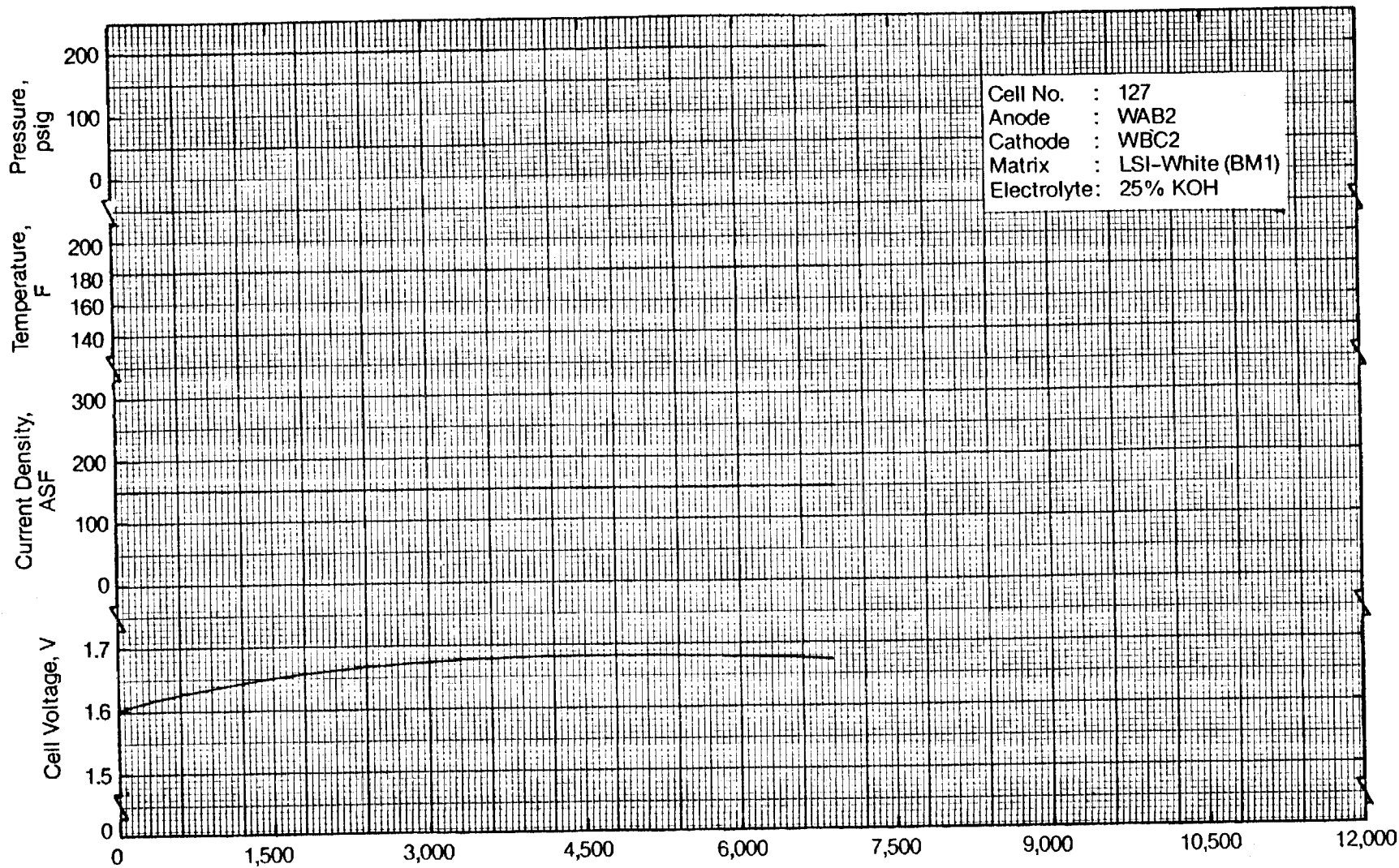

FIGURE 31 CELL PERFORMANCE VERSUS TIME, CELL NO. 127,
HIGH PRESSURE OPERATIONS

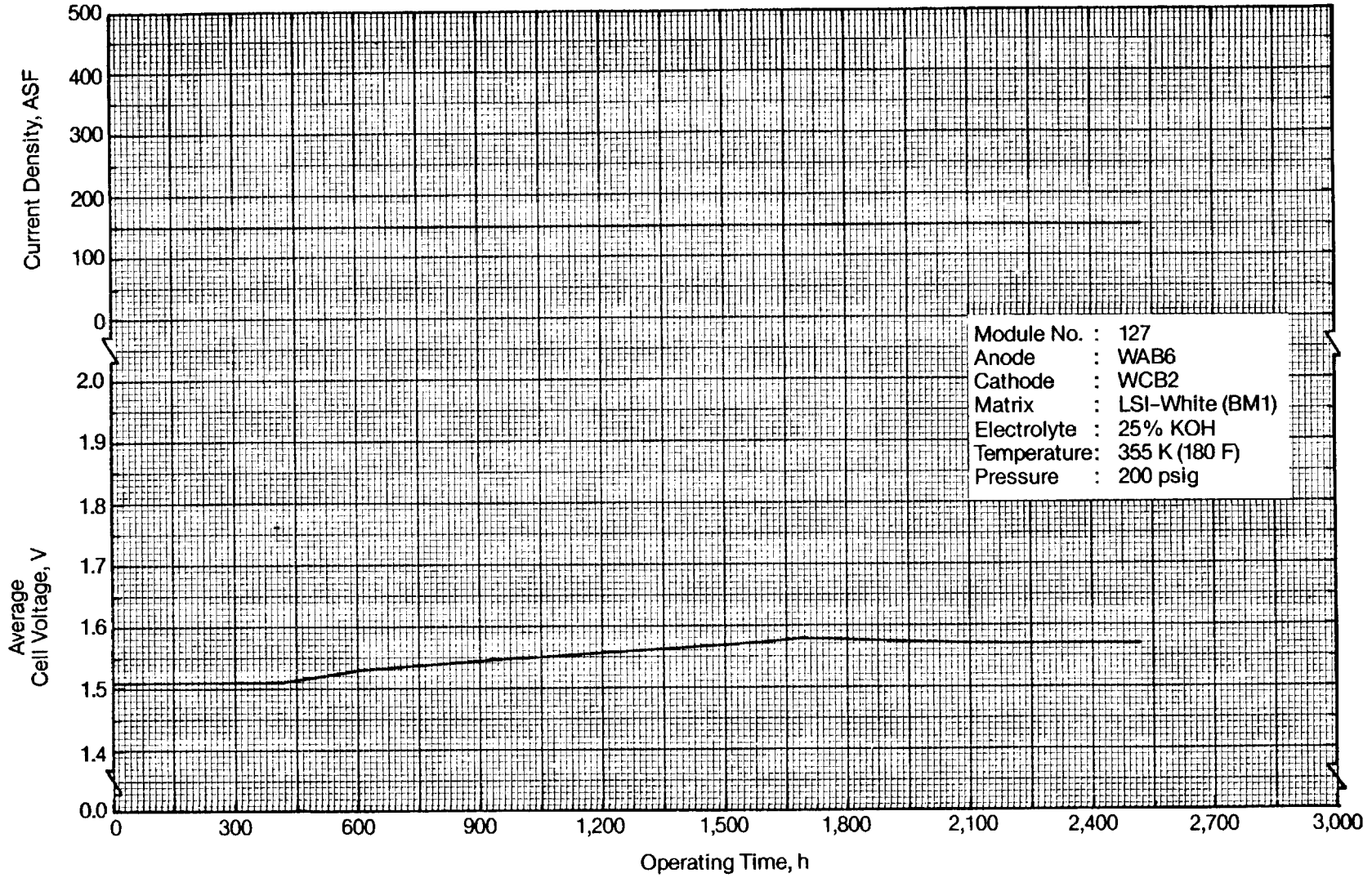

FIGURE 32 CELL PERFORMANCE VERSUS TIME, MODULE NO. 127

the modules. The performance showed that scale up of the static feed concept and associated cell hardware was accomplished without a loss in performance.

4. The 1.0 ft² unitized core concept demonstrated excellent operational capabilities in both 1.0 ft² modules. Based upon unitized core test results, the SFWE cell and module complexity has been reduced and module operational capabilities improved.
5. A Regenerative Fuel Cell Electrolyzer Subsystem (WS-6) was designed and fabricated for testing of the two 1.0 ft² modules. One of the modules tested in the WS-6 was then delivered to NASA JSC and integrated into the Regenerative Fuel Cell System Breadboard.
6. A study program was successfully completed to define further the regenerative fuel cell concept and to define a 10 kW, alkaline electrolyte based Engineering Model System (EMS) prototype. The results of the study are presented in a publication entitled; "Engineering Model System Study for a Regenerative Fuel Cell."

RECOMMENDATIONS

Based on the work completed the following recommendations are made:

1. Continue the endurance tests of the 0.1 ft² SFWE cells at ambient pressure and high pressure to expand the current SFWE data base.
2. Continue the endurance test of the six-cell 1.0 ft² module in the WS-6 subsystem and continue to characterize the subsystem at 300 psig.
3. Complete analysis and design studies for conversion of existing 1.0 ft² cell frame design to one with three compartments. This would eliminate the coolant compartment from the current cell design and result in overall subsystem simplification.
4. Evaluate multicell module designs, i.e., greater than six cells, for stray electrolysis elimination. Modules with 50 cells or more are envisioned for use in an RFCS.
5. Investigate use of lightweight thermoplastics in all WES-related components (CCA, FCA, 3-FPC) to further allow weight reductions in the SFWE subsystem.

REFERENCES

1. Chang, B.J.; Schubert, F.H.; Kovach, A.J.; Wynveen, R.A., "Engineering Model System Study for a Regenerative Fuel Cell," Study Report, Contract NAS3-21287, TR-376-30, Life Systems, Inc., Cleveland, OH September, 1984.
2. Schubert, F.H.; Lee, M.K.; Davenport, R.J. and Quattrone, P.D., "Water Electrolysis Systems: H₂ and O₂ Generation," Paper No. 78-ENAs03, Intersociety Conference on Environmental Systems, San Diego, CA; July 10-13, 1978.

3. Schubert, F.H.; Wynveen, R.A. and Jensen, F.C., "Development of an Advanced Static Feed Water Electrolysis Module," Paper No. 75-ENAs-30, Intersociety Conference on Environmental Systems, San Francisco, CA; July 21-24, 1975.
4. Schubert, F.H. and Wynveen, R.A., "Technology Advancement of the Static Feed Water Electrolysis Process," Final Report, Contract NAS2-8682, CR-152073, Life Systems, Inc., Cleveland, OH; November, 1977.
5. Kovach, A. J. and Schubert, F. H., "Development of Static Feed Water Electrolysis for Large Scale Hydrogen Production," Final Report, Contract S22723-S, Life Systems, Inc., Cleveland, OH; July 1984.
6. Burke, K.A. and Schubert, F.H., "Endurance Test and Evaluation of Alkaline Water Electrolysis Cells," Interim Report, Contract NAS3-21287, Life Systems, Inc., Cleveland, OH; November 1981.

