

~~UNCLASSIFIED~~

Copy 142
RM L51I07a

NACA RM L51I07a

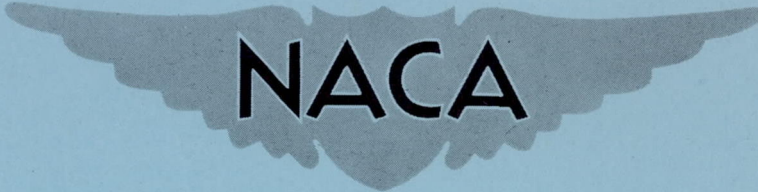

RESEARCH MEMORANDUM

ADDITIONAL STUDIES OF THE STABILITY AND CONTROLLABILITY
OF AN UNSWEPT-WING VERTICALLY RISING AIRPLANE MODEL
IN HOVERING FLIGHT INCLUDING STUDIES OF
VARIOUS TETHERED LANDING TECHNIQUES

By William R. Bates, Powell M. Lovell, Jr.,
and Charles C. Smith, Jr.

Langley Aeronautical Laboratory
Langley Field, Va.

~~CLASSIFIED~~

This material contains information affecting the national defense of the United States within the meaning of the espionage laws, Title 18, U.S.C., Sections 793 and 794, and the transmission or revelation of which in any manner to unauthorized person is prohibited by law.

NATIONAL ADVISORY COMMITTEE FOR AERONAUTICS

WASHINGTON

November 6, 1951

~~UNCLASSIFIED~~

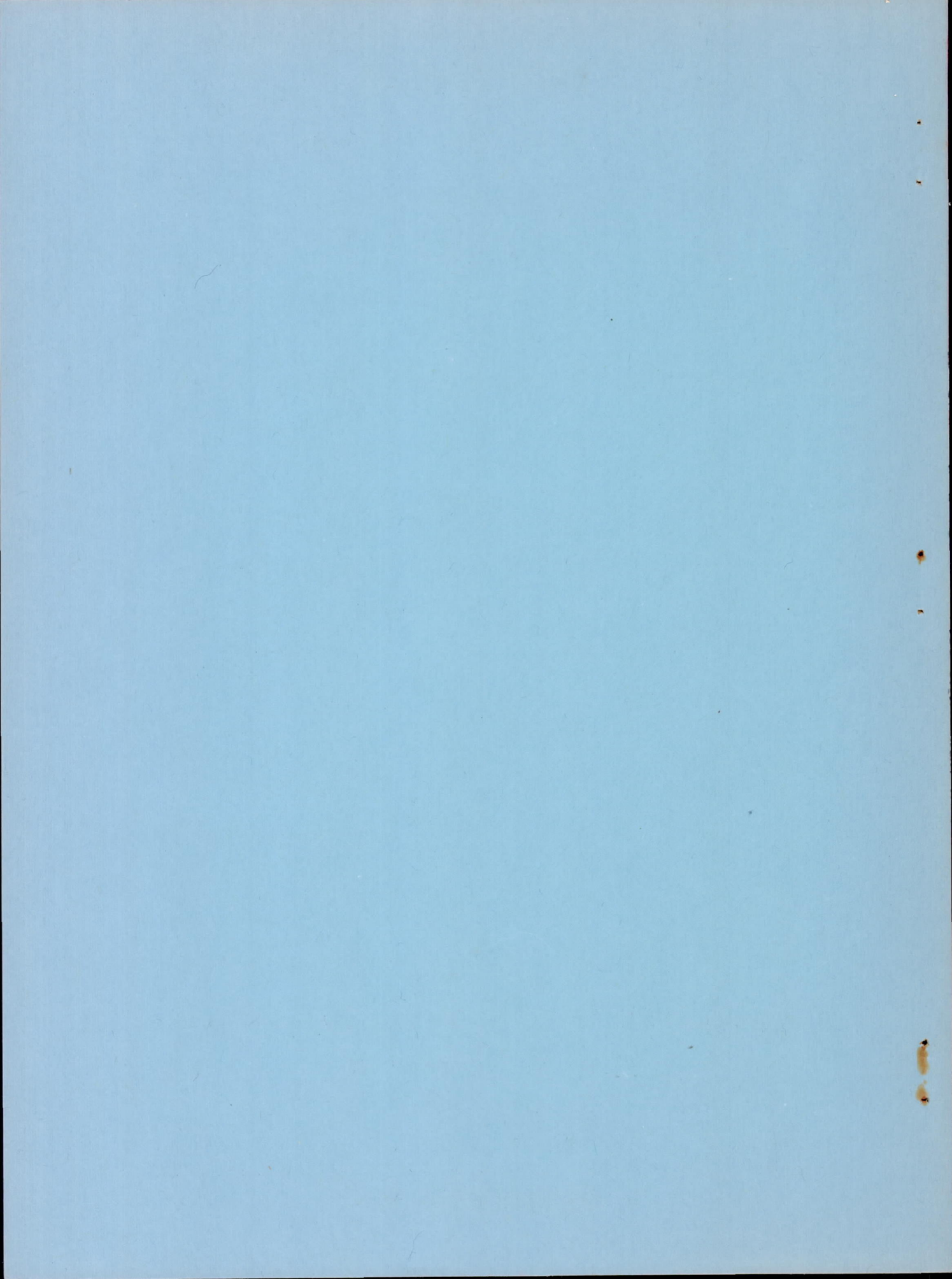

NATIONAL ADVISORY COMMITTEE FOR AERONAUTICS

RESEARCH MEMORANDUM

ADDITIONAL STUDIES OF THE STABILITY AND CONTROLLABILITY

OF AN UNSWEPT-WING VERTICALLY RISING AIRPLANE MODEL

IN HOVERING FLIGHT INCLUDING STUDIES OF

VARIOUS TETHERED LANDING TECHNIQUES

By William R. Bates, Powell M. Lovell, Jr.,
and Charles C. Smith, Jr.

SUMMARY

This paper is the third of a series presenting the results of an investigation that is being made to determine the stability and control characteristics of a flying model of an unswept-wing vertically rising airplane. This model is essentially a conventional airplane model with a large dual-rotating propeller and sufficient power to take off and land vertically and with conventional controls operating in the propeller slipstream. The part of the investigation covered by this paper consisted of flight tests to determine the effects of some miscellaneous factors on the stability and control characteristics for the hovering condition and to determine the behavior of the model in landings made by various techniques involving the use of lines for pulling the model in for a landing.

The unstable pitching oscillation encountered in previous hovering tests was made less unstable but could not be eliminated by use of a rate-gyro automatic stabilizing device which moved the elevator to oppose pitching velocities. For comparable control size and deflection, the maneuverability of the model was greater with tail controls than with direct lift controls on the wings, but the model could be flown more smoothly with wing controls particularly when hovering near the ground. The rolling motions of the model could be controlled fairly smoothly and easily by means of ailerons on the inboard part of the wings despite large fluctuations in propeller torque. In gusty winds (average velocity of about 13 miles per hour for the full-scale airplane) the model was considerably more difficult to fly than in still air and could not be held over a spot on the ground but sustained flights were possible.

Satisfactory landings could be made by pulling the model horizontally into a saddle by means of a line attached near the center of

gravity of the model. Landings in which the model was pulled down by means of two lines attached to its wing tips were the easiest to perform. Landings in which the model was pulled down by means of a line attached to its tail, however, were completely unsuccessful because the restraint of the line on the tail of the model caused a divergence as the model neared the ground.

INTRODUCTION

An investigation is being conducted by the Langley free-flight-tunnel section to determine the stability and control characteristics of an unswept-wing vertically rising airplane model. The flying model is essentially a conventional-airplane model with a large dual-rotating propeller and sufficient power to take off and land vertically. The model has a rectangular wing, a cruciform tail, and rectangular surfaces, and is controlled by conventional-airplane control surfaces operating in the propeller slipstream. The investigation consists of flights by the trailing-cable technique, force tests, and theoretical analysis. The results of the initial hovering flight tests of the model are presented in reference 1. These tests showed the stability and controllability in pitch and yaw for the model in its original configuration in flights made in still air and away from the interference effects of the ground and side walls. The results of tests to determine the effect of the proximity of the ground on the stability and control characteristics of the model are presented in reference 2. This part of the investigation included flight tests to determine the dynamic behavior of the model when it was hovering near the ground and in take-offs and landings and also included force tests and slipstream velocity surveys to determine the effect of the ground on the static stability and control effectiveness.

The present investigation included an extension of the hovering-flight tests to determine the effect on the stability of the model of a rate-gyro automatic stabilizing device which moved the elevator to oppose pitching velocities. Flight tests were also made to determine the controllability of the model with manual roll control instead of the automatic roll control used in previous phases of the investigation, to determine the controllability with direct lift wing controls instead of the conventional tail controls and to study the hovering-flight behavior of the model in gusty air. This paper also includes the results of flight tests to study the behavior of the model in landings made by various techniques involving the use of tethering lines for pulling the model in for a landing. In these landing techniques the model was either pulled down to the ground by a single tethering line attached to its tail or by twin tethering lines attached to its wing tips or pulled horizontally into a saddle by a tethering line attached near the center of gravity. The study of the behavior of the model in

landings by these techniques also included flights to determine the effects on the flight behavior of the model of a block suspended from the model by a line to represent a tethering cable and hook swinging freely. In addition to these flight tests some force tests were also made to determine the aerodynamic center of the model in normal level flight so that a reasonable location of the center-of-gravity could be determined. For most flights the stability, controllability, and the general flight behavior of the model were determined qualitatively from the pilot's observations and motion-picture records of the flights. The stability of the model with the rate-gyro automatic stabilizing device was also determined quantitatively from time histories of a flight.

The results of a series of tests on a delta-wing vertically rising airplane configuration are presented in reference 3. These results may be of interest to the reader for comparison with the results for the conventional configuration.

NOMENCLATURE AND SYMBOLS

Since the present model and tests represent an airplane in a very unusual flight condition, there is little precedent with regard to nomenclature, axes, or symbols. The conventional airplane-type body system of axes has been selected for use in describing the motions of the model for hovering flight. The body axes are an orthogonal system with the origin at the center of gravity in which the X-axis (fuselage axis) is parallel to the thrust line, the Z-axis (normal axis) is in the plane of symmetry and perpendicular to the X-axis, and the Y-axis (spanwise axis) is perpendicular to the XZ-plane. A sketch showing these axes, and the positive direction of forces, moments, and displacements is presented in figure 1. The positive directions shown in this figure are the same as those previously given in reference 1 except that the positive direction along the direction of the Z-axis has been reversed to be more in accord with accepted convention.

For convenience in discussion, the motions along the axes are referred to by the terms commonly used with regard to airplanes in the normal-flight regime; that is, motions along the fuselage axis (X-axis) are referred to as longitudinal motions, motions along the spanwise axis (Y-axis) are referred to as lateral motions, and the motions along the normal axis (Z-axis) are referred to as normal motions. The controls and angular motions about the axes are referred to by the terms commonly used with regard to the airplane in the normal-flight regime; that is, the rudders on the vertical tails produce yaw about the normal (Z) axis, deflection of the ailerons on the wings produces roll about the

longitudinal (X) axis, deflection of the elevators produces pitch about the spanwise (Y) axis.

The definitions of the symbols used in the present paper are as follows:

| | |
|----------|---|
| C_Z | normal-force coefficient (Z/qS) |
| C_X | longitudinal-force coefficient (X/qS) |
| C_m | pitching-moment coefficient (M/qSc) |
| T_c' | effective thrust coefficient T_e/qS |
| Z | normal force, positive downward, pounds |
| X | longitudinal force, positive forward, pounds |
| M | pitching moment, foot-pounds |
| T_e | effective thrust, (propeller removed drag minus propeller operating drag), pounds |
| L | rolling moment, foot-pounds |
| N | yawing moment, foot-pounds |
| Y | lateral force, positive to right, pounds |
| α | angle of attack of the X-axis, degrees |
| V | wind velocity, feet per second |
| t | time, seconds |
| θ | angle of pitch, degrees |
| ψ | angle of yaw, degrees |
| ϕ | angle of bank, degrees |
| q | dynamic pressure, pounds per square foot, $\left(\frac{1}{2}\rho V^2\right)$ |
| ρ | mass density, slugs per cubic foot |
| Ω | propeller angular velocity, radians per second |

| | |
|----------------|---------------------------------------|
| S | wing area, square feet |
| c | wing chord, feet |
| R | propeller radius, feet |
| δ_e | elevator deflection, degrees |
| $\dot{\theta}$ | pitching velocity, radians per second |
| z | normal displacement, feet |

MODEL

The flying model, which is illustrated in figures 2 and 3, was essentially a conventional-airplane model with a large dual-rotating propeller and sufficient power to take off and land vertically. The model had a rectangular wing, cylindrical fuselage, a cruciform tail with rectangular surfaces, and was controlled by conventional-airplane control surfaces operating in the propeller slipstream. The geometric characteristics of the model are presented in table I. It may be noted that some of the model dimensions presented in figure 3 and table I are different from those presented in reference 1. The values in the present paper are the correct values. For a few tests in which the controllability of the model with direct lift controls on the wing was studied, the model was provided with a rectangular vertical wing which is shown by the dashed lines on figure 3. The purpose of these wing controls was to produce horizontal forces directly instead of by pitching and yawing the model with the elevator and rudder so that the thrust produced these forces. The wing controls, of course, also cause some pitching and yawing, primarily because of the downwash from the wings over the tail surfaces. The model was powered by a 5-horsepower variable-frequency electric motor, the speed of which was changed to vary the thrust. The power for the motor and electric solenoids and the air for the servomechanisms were supplied through wires and plastic tubes which trailed from the tail of the model.

Test Equipment and Technique

Most of the flight investigation was conducted in the facility used by the Langley free-flight-tunnel section for flight testing hovering models by the trailing-flight-cable technique. This facility consists of a 24-foot square open-top cage 15 feet high which is located in a large building that provides protection from outside turbulence. The purpose of this cage is to provide protection for the operators and

observers without causing interference with the natural circulation produced by the slipstream. A sketch of the test area with the model and the operators in position is shown in figure 4. Some flight tests were also made outdoors and in the return passage of the Langley full-scale tunnel, which consisted essentially of free air. The force tests were made in the Langley free-flight tunnel.

A safety rope (see fig. 4) suspended from above is attached to the propeller hub by means of a swivel joint to prevent crashes in case of a power failure or control malfunction. During flight the rope is kept slack so that it does not appreciably influence the motions of the model. In order to insure that the rope is generally slack, several feet of the rope are allowed to lie on a guard mounted in front of the propeller. This propeller guard is constructed primarily of $\frac{1}{8}$ -inch aluminum tubing and string.

For most of the flights the rolling motions of the model were controlled automatically by a displacement-type autopilot which kept the model oriented in roll with respect to the pilot's position. The reference for the simple-displacement type of roll autopilot is a string from the autopilot pickoff to the wall of the building. The string runs through a pulley on the wall and has a small weight attached to the free end to maintain a small constant tension in the string. The small constant force exerted by the string does not affect the stability of the model but does produce a small out-of-trim moment which is easily compensated by adjusting the trim setting of the proper control. For flights in which the model was maneuvered by means of the flaps on the horizontal and vertical wings the elevators were held fixed and the rudders were operated differentially for roll control and were controlled automatically by the displacement-type autopilot. For a few flights, the model was equipped for manual control of the ailerons to permit a study of the controllability of the model in roll.

For the normal configuration, the model was maneuvered by the elevator and rudder controls which were remotely controlled by the pilot by means of two small control sticks on his control box. One of these sticks operates the elevator and the other operates the rudder. In flying the model, the pilot operates one of these control sticks with each hand. For the study of the controllability of the model with direct lift controls on the wings, the pilot controlled the flaps on the horizontal and vertical wings instead of the elevator and rudder. Two operators in addition to the pilot are required for flying the model: one to control the power to the propellers and one to control the safety rope. For some flights two pilots were used in order that various phases of the behavior of the model could be studied more carefully. For example, separate pilots were sometimes used to control the rudder and elevator, or a separate pilot was used to control the ailerons manually. The pilot

and power operator are the principal observers because they have control of the model and can obtain qualitative indications of the stability and control characteristics. Movie cameras are placed in advantageous locations for obtaining quantitative data on the stability of the model and its response to control movements.

The speed of the model motor was controlled by varying the frequency of the current supplied to the motor. This change in frequency was accomplished by varying the speed of the alternating-current generator by controlling the power supply of its direct-current driving motor. Since these units were standard heavy-duty pieces of equipment (5-horsepower motor and 20-horsepower generator) the time required for these units to change speed plus the time required for the model motor to change speed introduced an appreciable time lag in the control of the thrust of the model.

For some flights a rate-sensitive automatic stabilizing device was installed in the elevator control system to oppose pitching motions. The sensing element for this automatic stabilizer was a rate gyro which produced a signal proportional to the rate of pitch. This signal controlled the servo which moved the elevator in proportion to the gyro signal, or rate of pitch. The control surfaces were actuated by flicker-type (full-on, full-off) pneumatic servos which were controlled by electric solenoids except where proportional control mechanisms were used. These proportional control mechanisms were used to actuate the roll control as well as to actuate the elevator for tests in which the rate-gyro automatic stabilizing device was used.

The flight technique is explained by describing a typical flight. The model hangs on a safety rope and the power is increased until the model climbs to the desired altitude. The safety rope is allowed to coil on top of the propeller guard and the rope operator then recovers any excess slack or releases more rope as required during the flight. During the flight the power is regulated to keep the model at the desired altitude. The pilot keeps the model as near the center of the test area as possible during the climb until the model is in a steady hovering condition; then he performs the maneuvers required for the particular tests and observes the stability and control characteristics.

The same technique and equipment as far as safety rope, autopilot, pilot's control box, and power equipment was adopted for outdoor tests and tests in the return passage of the Langley full-scale tunnel to study the behavior of the model in gusty air. The only equipment change that was necessary for these tests was the provision for overhead supports for the safety rope.

TESTS

All of the flight tests were made with the center of gravity located at the leading edge of the wing. The stability, controllability, and the general flight behavior of the model were determined in various cases, either qualitatively from the pilot's observations or quantitatively from motion-picture records of the flights. General flight behavior is the term used to describe the over-all flying characteristics of a model and indicates the ease with which the model can be flown. In effect, the general flight behavior is much the same as the pilot's opinion of the flying qualities of an airplane and indicates whether stability and controllability are adequate and properly proportioned. In addition to these flight tests some force tests were also made to determine the aerodynamic center of the model in the normal low angle-of-attack flight conditions.

Hovering-Flight Tests

Hovering-flight tests were made to determine the effect of the rate-gyro automatic stabilizing device on the longitudinal stability of the model. Calibration of an automatic stabilizing device similar to the one used in this investigation showed that the lag of the complete unit (rate gyro and servo) was very small, only 0.03 second or about 3° phase lag for the pitching oscillation. The tests covered a range of values of response (ratio of elevator deflection to pitching angular velocity $\delta_e/\dot{\theta}$). Most of the results of this part of the investigation were obtained qualitatively from visual observation of the motions of the model; but, for one condition, time histories of the uncontrolled motions of the model were obtained by means of motion-picture records.

The flight tests also included an investigation of the stability and control and general flight behavior of the model when flap-type controls on the horizontal and vertical wings were used instead of the normal elevator and rudder controls. The purpose of these tests was to provide information for a comparison of the behavior of the model with wing controls with that of the same model with the normal tail controls (covered by references 1 and 2). The tests included hovering flights at a considerable height above the ground and also hovering flights near the ground to determine the effect of ground proximity on the stability and control and general flight behavior of the model. No attempt was made to study simultaneous use of both wing and tail controls. All of the results obtained in these tests were in the form of qualitative observations by the pilot.

Flight tests were also made to determine the controllability of the model in roll. In all of the previous flight tests of this model

(references 1 and 2) the ailerons had been controlled automatically by a displacement-type autopilot. The purpose of the present tests was to evaluate the controllability of the model in roll when it was controlled by a human pilot. The results obtained from these tests were also in the form of qualitative observations of the controllability of the model by the pilot.

In addition to these three phases of the investigation, which were conducted in still air, the investigation also included flight tests of the model to determine its behavior in gusty air. Some of these tests were made outdoors and some were made at low speeds in the return passage of the Langley full-scale tunnel. Only qualitative indications of the controllability and general flight behavior were obtained in this part of the investigation.

Landing Tests

Sketches are presented in figure 5 to illustrate the various landing techniques involving the use of lines for pulling the model in for a landing. For the technique shown in figure 5(a), the model was pulled horizontally into a saddle by means of a line attached near the center of gravity of the model. The line was actually attached on the surface of the fuselage at the longitudinal station at which the center of gravity was located; that is, the attachment point was on the Z-axis at the surface of the fuselage. In making landings by this technique, the pilot trimmed the elevator to pitch the model away from the saddle so that the line was always in tension. For the wing-tethering technique shown in figure 5(b), the model was pulled down by means of two lines attached to its wing tips at the 0.10-chord station. These lines passed through rings on the ground that were farther apart than the attachment points on the wing in order to provide stability of attitude. In making landings by this technique the power operator applied some excess power and the model was pulled down by means of the tethering lines. For the tail-tethering technique shown in figure 5(c) the model was pulled down by means of a line attached to its tail. In making landings by this technique, as in the case for the wing-tethering technique, excess power was applied to the model and it was pulled down by means of the tethering line. Only qualitative indications of the controllability and general flight behavior were obtained for the landing investigation.

RESULTS AND DISCUSSION

The initial tests of the model, described in reference 1, were made for two center-of-gravity locations to show the effect of center-of-gravity location because the proper location had not been determined at

the time of those tests. The center-of-gravity location for an airplane of this type will probably be largely determined from considerations of stability in normal level flight because the airplane is required to have good stability for the normal operating conditions. Prior to the present flight tests, therefore, force tests were made to determine the location of the aerodynamic center of the model so that the center of gravity could be located in a position that would give a reasonable degree of stability at low angles of attack. The results of these tests with the center of gravity located at the leading edge of the wing are presented in figure 6. Although these data do not show the static stability exactly because the model was not properly trimmed, they indicate that the aerodynamic center of the model was about 30 percent of the chord behind the leading edge of the wing. This indication was obtained from the slope of the pitching-moment curves for thrust coefficients of 0.03 and 0.34 at the normal-force coefficients 0.10 and 0.56, respectively, for which these power conditions represent full power. Since the static longitudinal stability of the model was not unreasonably large when the center of gravity was located at the leading edge of the wing (which was one of the locations covered in the tests described in references 1 and 2), this location was chosen for the present series of flight tests so that these test results would be directly comparable with those of the previous tests.

Motion pictures illustrating the results of several flights of the model in the configurations discussed herein are available on loan from the NACA Headquarters, Washington, D. C. The results of this investigation are illustrated more graphically by the flight scenes of this motion picture than is possible by a written presentation.

Hovering Flight

Effect of rate-sensitive autopilot on pitching motion.- The results of the original tests presented in reference 1 show that the uncontrolled pitching motion of the model consisted of a fairly long period unstable oscillation. Although this oscillation could be controlled fairly easily, the instability might be considered undesirable for certain operations requiring long periods of hovering flight. The tests of the model with the rate-gyro stabilizing device were made, therefore, to determine whether the stability of pitching motions could be made satisfactory with an automatic stabilizing device or pitch damper similar to the rate-gyro yaw dampers now being used on a number of airplanes. As pointed out previously, this pitch damper moved the elevator to oppose the pitching velocity of the model. Several flight tests were made using progressively larger degrees of control response without any improvement in the stability of the pitching motions of the model being noticeable to the pilot. Finally to determine whether the pitch damper would have any noticeable effect even with extremely high control

response, the control gearing was made as high as possible with the mechanical setup available and the gyro was made as sensitive as possible by increasing the gyro speed to its limit and by removing its centering springs. Even for this extreme condition, the stability of the model did not appear to the pilot to be greatly improved. Figure 7 presents a comparison of time histories of the uncontrolled motions of the model for this condition with time histories taken from reference 1 for the model without the stabilizing device. These data show that the pitch damper improved the stability of the pitching oscillation but did not make the model stable. A calibration of the stabilizing system for this condition showed that the response of the elevator to the rate of pitch $\delta_e/\dot{\theta}$ was 2. An estimate of the damping in pitch for the basic model and that provided by the autopilot indicated that, for this extremely high response, the rate-gyro stabilizing device increased the damping in pitch of the model to a value about 7 times as great as that of the basic model.

Wing controls.- On the basis of approximately equal control deflections, the tail controls seemed more powerful than the wing controls. The pilot had more of a feeling of security when flying the model with the tail controls because of the greater maneuverability available for effecting a recovery following a disturbance. The model could actually be flown more smoothly and was easier to keep in a particular spot, however, when controlled with the wing controls. This impression of greater smoothness probably resulted partly from the fact that less pitching and yawing were required when controlling the model to keep it in one particular spot. Since it was not necessary to yaw or pitch the model as much with the wing controls as with the tail controls, the vertical component of the thrust remained more nearly constant and the power operator consequently felt that it was easier to hold the model at a given altitude.

The model was considerably easier to fly near the ground with the wing controls than with the tail controls because the wing controls were always sufficiently far above the ground to avoid the adverse ground effect which could cause a serious reduction in the effectiveness of the tail controls. This ground effect is discussed in detail in reference 2. The data presented in this reference show that the velocity in the slipstream was reduced as the slipstream approached the ground. This reduction in velocity did not occur to any appreciable extent at heights greater than one propeller diameter. The ground effect could not therefore affect the wing controls directly because they were more than one diameter above the ground even when the landing gear was on the ground. There was probably some secondary effect of the ground on the yawing and pitching moments caused by the change in downwash of the wings on the tails. This effect, however, was not noticeable to the pilot of the model.

Manual aileron control.- As previously pointed out, for most of the flights the ailerons were controlled automatically by a displacement-type autopilot which kept the model oriented in roll with respect to the pilot's position. In the preliminary tests this autopilot was used to make the flights easier and more reliable (by eliminating the possibility of pilot error) in order to facilitate the study of the yawing and pitching phases of the model motions because the study of these phases was believed to be more important. The stability and control of the rolling motions seemed fairly simple and straightforward and were, consequently, left for later study. The studies of the stability and control of the model assumed added importance, however, when large random fluctuations in propeller torque (described in reference 2) were discovered.

The results of the present study of the behavior of the model in roll have shown that the pilot could control the rolling motions of the model fairly easily despite the fluctuations of propeller torque. These torque fluctuations appeared to the pilot as irregular abrupt changes in trim which occurred at fairly long intervals.

Effect of gusts on general flight behavior.- A few tests were made outdoors and in the return passage of the Langley full-scale tunnel to study the effects of gusts and moderate cross winds on the flight behavior of the model. These tests were started outdoors but because of inclement weather the outdoor tests were discontinued and the gust tests were continued in the return passage of the full-scale tunnel. In the outdoor tests the velocity of the wind varied in gusts from 0 to 5 miles per hour. For the tests in the return passage the average velocity was approximately 5 miles per hour with maximum and minimum velocities of 9 miles per hour and 0 miles per hour, respectively. An indication of the degree of roughness of the air in the return passage of the full-scale tunnel can be obtained from the sample time history of the velocity presented in figure 8. The degree of roughness encountered in the return passage of the full-scale tunnel is believed to represent a fairly severe condition for a full-scale airplane. If the data of figure 8 are scaled up as though the model were a 0.13-scale model, they indicate that the conditions in the tests represented a variation of velocity of about 13 miles per hour from a mean value of 13 miles per hour.

The model was considerably more difficult to fly in rough air than in still air although sustained flight was possible in all the tests, both outdoors and in the full-scale-tunnel return passage. In order to make sustained flights, however, it was necessary to use somewhat larger control deflections than were required in still air to enable the pilot to effect a recovery after violent gust disturbances. Even with these greater control deflections it was not possible to keep the model over a spot on the ground.

Landing Techniques

The results of a previous investigation of the behavior of the model for unrestrained take-offs and landings are presented in reference 2. These data should be useful for comparison with the results obtained in the present investigation for landings by various techniques involving the use of tethering lines (see fig. 5). For convenience in discussion, these landing techniques are referred to by the terms applied in this figure: center-of-gravity tethering with saddle, wing tethering, and tail tethering.

Center-of-gravity tethering with saddle.- Satisfactory landings could be made by pulling the model horizontally into a saddle by means of a line attached near the center of gravity of the model. In making these landings the pilot trimmed the elevator to pitch the model away from the saddle so that the line was always in tension. Since the tethering line was attached to the model at the surface of the body, the model attained a state of equilibrium in pitched attitude. The longitudinal motions of the model appeared stable in this condition and little or no elevator control was required during the time the model was being pulled into the saddle. The tethering line did not seem to stabilize the lateral motions, however, and continuous use of the rudder was required during the landings. In fact, the model seemed somewhat more difficult to fly in this condition than in normal hovering flight, especially when the tethering line was short.

Wing tethering.- Landings in which the model was pulled down by lines attached to each tip were very easy to perform. The tethering lines made the model completely stable in yaw and sidewise displacement so that no rudder control was required during landings. Very little elevator control was required during landings because the lines seemed to make the model almost completely stable. Since the lines were attached to the model 0.10 chord behind the center of gravity, they actually gave stable variations of normal force when the model deviated from the trimmed position and of pitching moment with angle of pitch but gave an unstable variation of pitching moment when the model deviated from the trimmed position.

Tail tethering.- The landings were unsatisfactory when the model was pulled down by a line attached to its tail because the model diverged as it approached the ground. This divergence occurred because the line introduced a severe instability of angle of pitch or yaw with horizontal displacement. When the model was disturbed and moved in the Y- or Z-direction, the line caused the model to yaw or pitch in the direction of the displacement. This yaw or pitch produced a force which caused the model to continue to move in the direction of the displacement. When the model was sufficiently near the ground and displaced sufficiently

far horizontally, the tail controls were not powerful enough to pitch or yaw the model with the tail restrained by the tethering line. It was not possible in these cases to tilt the model so it would return to its original position. This landing technique would become less unsatisfactory, however, if the tension in the line was reduced.

Effect of tethering cable and hook.- The swinging of a weight hanging on a line attached near the center of gravity had no appreciable effect on the stability and controllability of the model. This weight was intended to represent a tethering hook and cable which would be used to pull the airplane down for landings. The mass of the block (which represented about a 48-lb hook on a 12,000-lb airplane) was evidently too low to affect appreciably the motions of the model.

CONCLUDING REMARKS

The following results were obtained from hovering flight tests of an unswept-wing vertically rising airplane model with the center-of-gravity located at the leading edge of the wing:

1. The rate-gyro automatic stabilizing device which moved the elevator to oppose pitching velocities improved the stability of the unstable pitching oscillation of the model but did not make it stable.

2. For comparable control size and deflections, the maneuverability of the model was greater with tail controls than with direct lift controls on the wings but the model could be flown more smoothly with wing controls particularly when hovering near the ground.

3. The rolling motions of the model could be controlled fairly smoothly and easily by means of ailerons on the inboard part of the wings despite the large fluctuations in propeller torque.

4. In gusty winds (average velocity of about 13 miles per hour for the full-scale airplane) the model was more difficult to fly than in still air and could not be held over a spot on the ground but sustained flights were possible.

5. Satisfactory landings could be made by pulling the model horizontally into a saddle by means of a line attached near the center of gravity of the model.

6. Landings in which the model was pulled down by means of two lines attached to its wing tips were the easiest to perform.

7. Landings in which the model was pulled down by means of a line attached to its tail were completely unsuccessful because the restraint of the line on the tail of the model caused a divergence as the model neared the ground.

8. The swinging of a weight hanging from a line attached near the center of gravity to represent a tethering hook and cable had no appreciable effect on the stability or controllability of the model.

Langley Aeronautical Laboratory
National Advisory Committee for Aeronautics
Langley Field, Va.

REFERENCES

1. Bates, William R., Lovell, Powell M., Jr., and Smith, Charles C., Jr.: Dynamic Stability and Control Characteristics of a Vertically Rising Airplane Model in Hovering Flight. NACA RM L50J16, 1951.
2. Smith, Charles C., Jr., Lovell, Powell M., Jr., and Bates, William R.: Effect of the Proximity of the Ground on the Stability and Control Characteristics of a Vertically Rising Airplane Model in the Hovering Condition. NACA RM L51G05, 1951.
3. Lovell, Powell M., Jr., Bates, William R., and Smith, Charles C., Jr.: Dynamic Stability and Control Characteristics of a Delta-Wing Vertically Rising Airplane Model in Take-Offs, Landings, and Hovering Flight. NACA RM L51H13a, 1951.

TABLE I
GEOMETRIC CHARACTERISTICS OF THE MODEL

| | |
|--|--------|
| Weight, lb | 27.5 |
| Over-all length of model, in. | 56.68 |
| Fuselage: | |
| Length, in. | 44.00 |
| Diameter, in. | 6.00 |
| Horizontal wing: | |
| Rectangular plan form | |
| Flat-plate section (0.5 thick) | |
| Aspect ratio | 5.00 |
| Area, sq in. | 376.71 |
| Span, in. | 43.40 |
| Chord, in. | 8.68 |
| Span of aileron, in. | 15.67 |
| Chord of aileron, in. | 2.17 |
| Vertical wing: | |
| Rectangular plan form | |
| Flat-plate section (0.25 thick) | |
| Aspect ratio | 4.80 |
| Area, sq in. | 118.80 |
| Span, in. | 23.86 |
| Chord, in. | 4.97 |
| Span of control, in. | 8.90 |
| Chord of control, in. | 1.49 |
| Horizontal and vertical tails: | |
| Rectangular plan form | |
| Flat-plate section (0.25 thick) | |
| Aspect ratio | 3.36 |
| Area (horizontal or vertical total), sq in. | 169.34 |
| Span, in. | 23.85 |
| Chord, in. | 7.10 |
| Span of control, in. | 23.85 |
| Chord of control, in. | 2.13 |
| Moment arm, distance from leading edge of wing to hinge line of controls, in. | 30.06 |

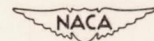
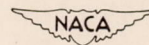

TABLE I

GEOMETRIC CHARACTERISTICS OF THE MODEL - Concluded

Propellers:

| | |
|--|------------|
| Eight-blade dual-rotating | |
| Diameter, in. | 23.85 |
| Hamilton Standard design, drawing number | 3155-6-1.5 |
| Solidity, one blade | 0.0475 |
| Gap, in. | 3.00 |
| Moment arm, distance from leading edge of wing to center of gap between propellers, in. | 14.81 |



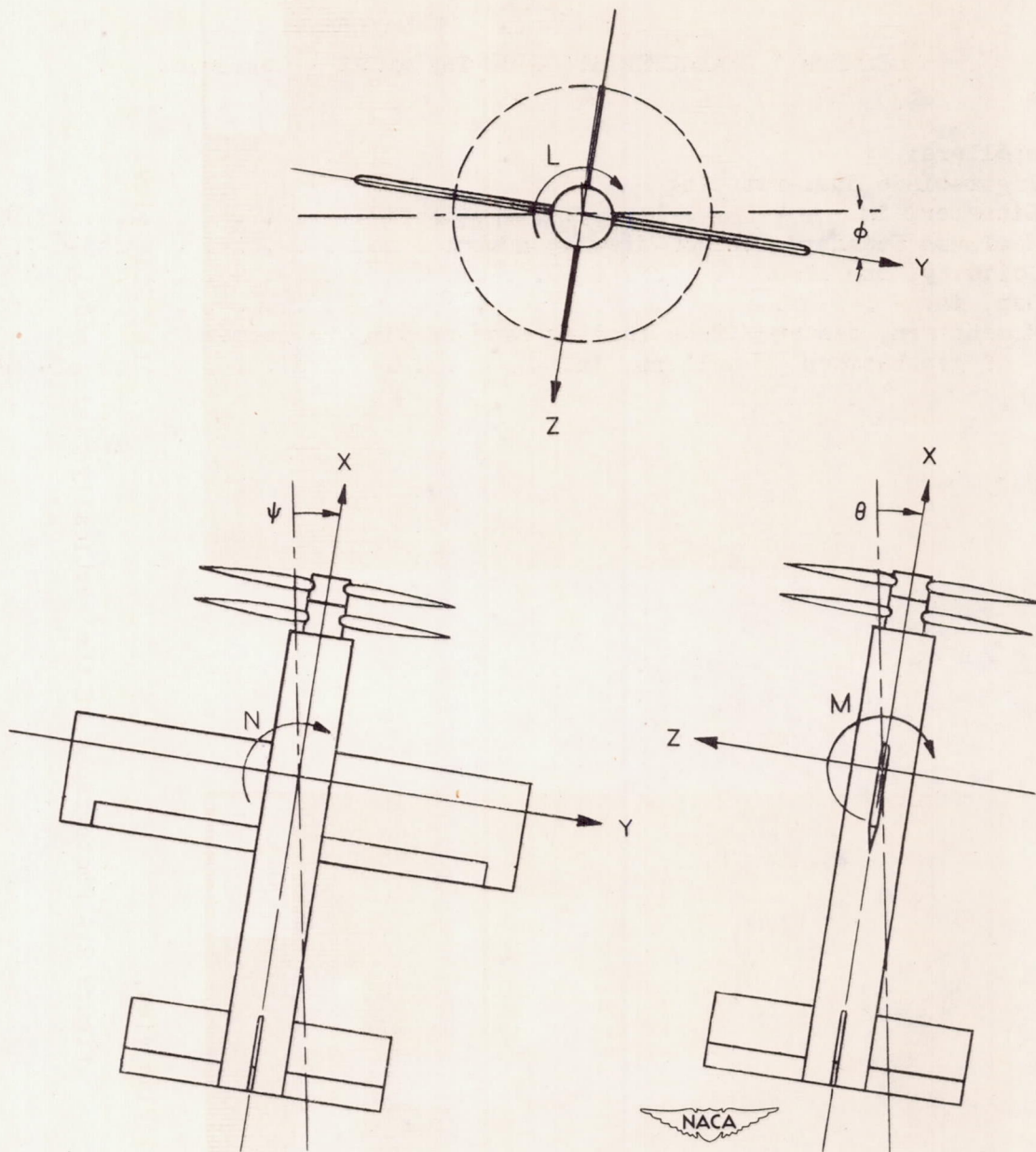
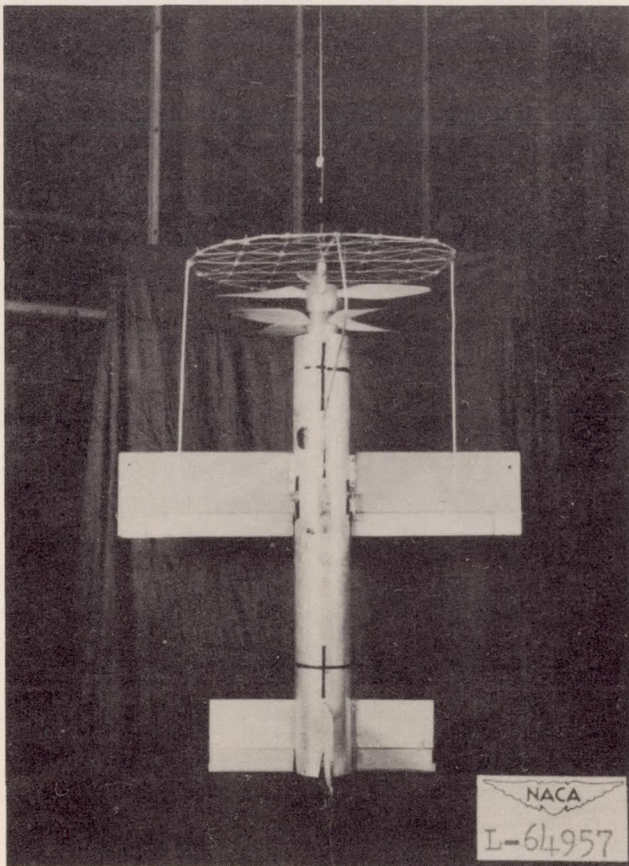
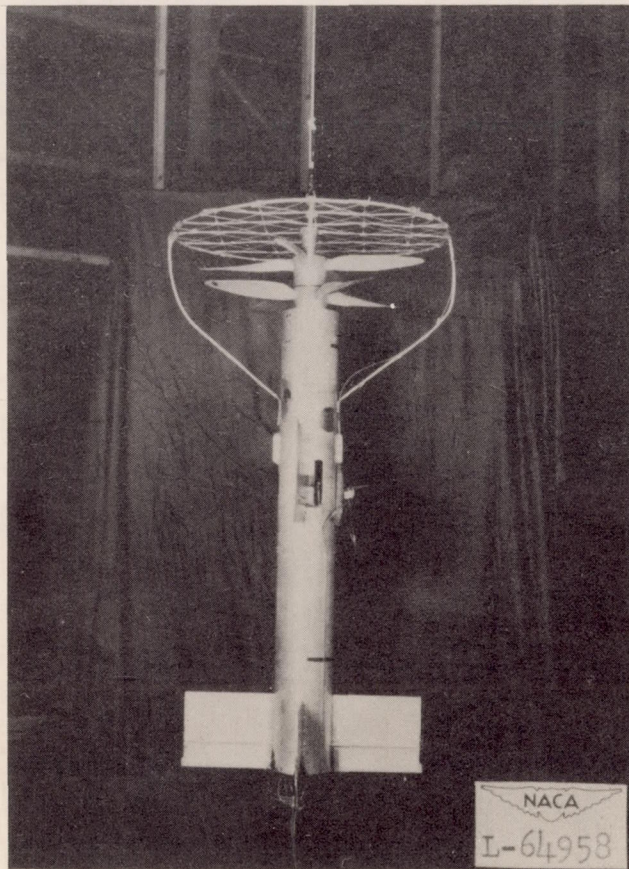

Figure 1.- The body system of axes. Arrows indicate positive directions of moments, forces, and angular displacements.



(a) Plan view.



(b) Side view.

Figure 2.- Photographs of the vertically rising model.

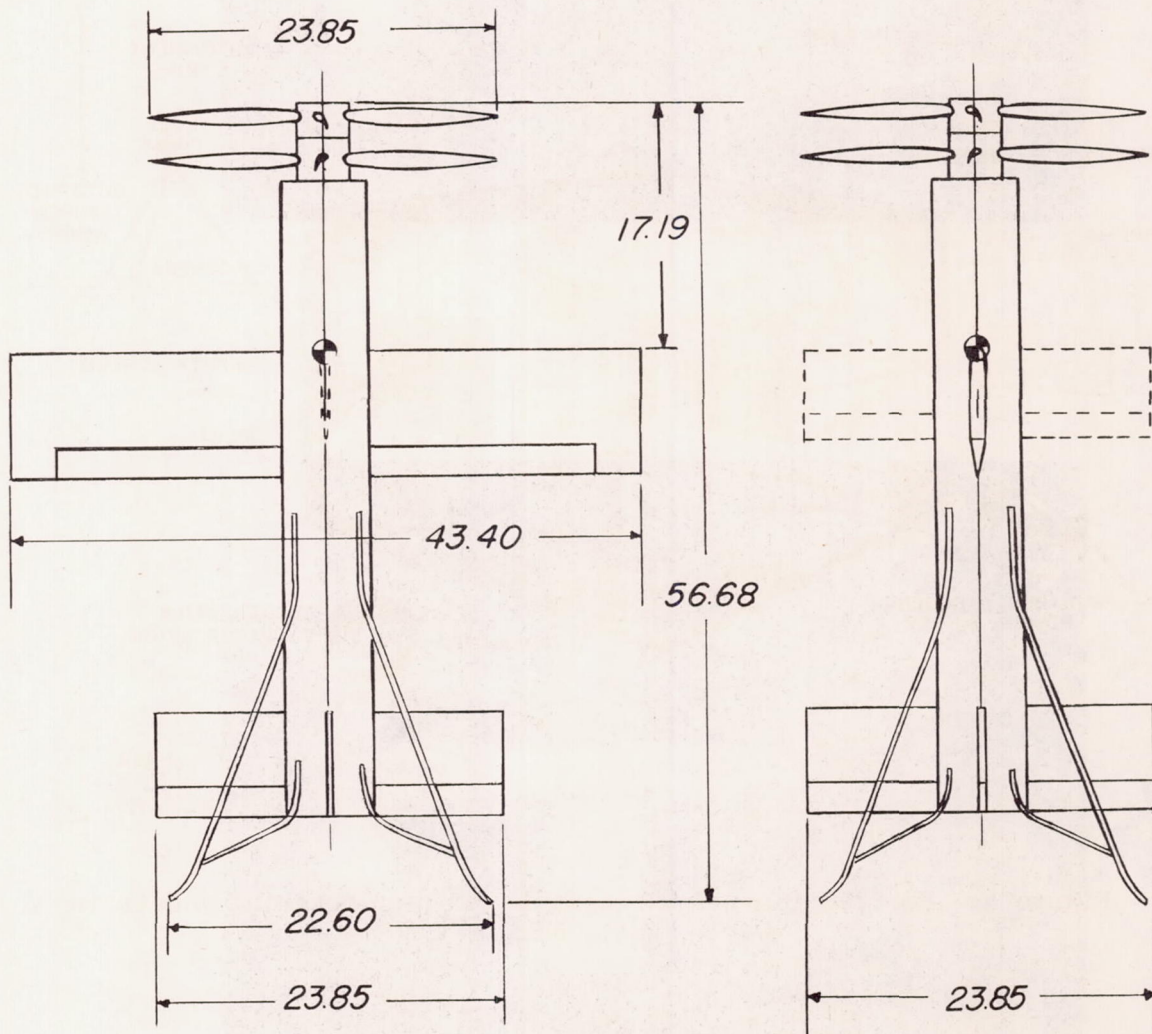
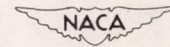
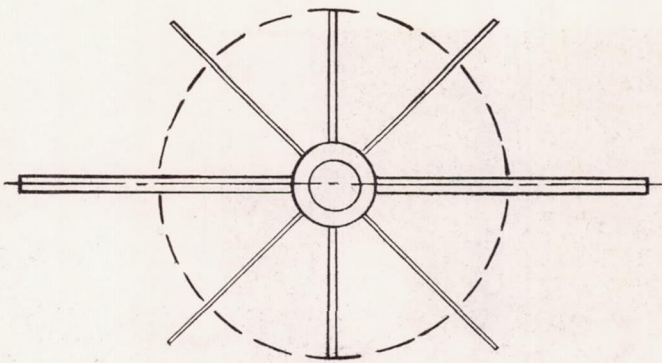
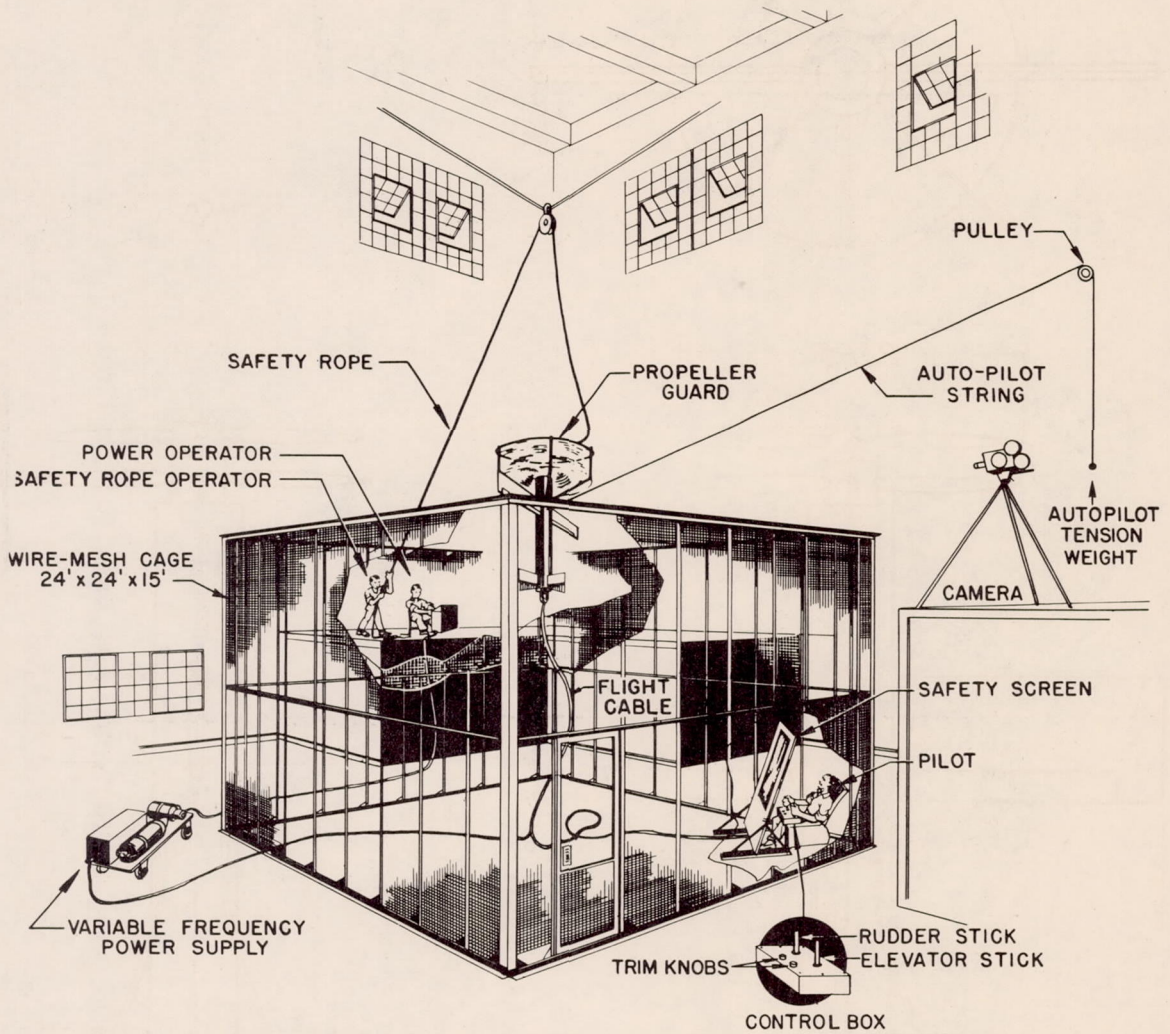

Figure 3.- Vertically rising airplane model showing the important dimensions. All dimensions in inches.



NACA
L-66871.1

Figure 4.- Facility used for flight testing of hovering models in still air.

CONFIDENTIAL

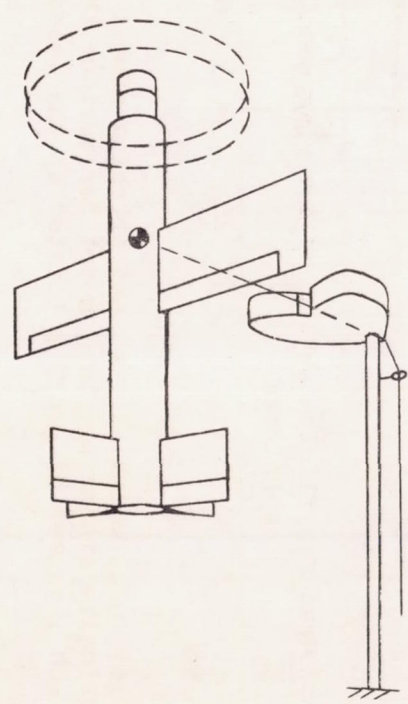

(a) Center-of-gravity tethering with saddle.

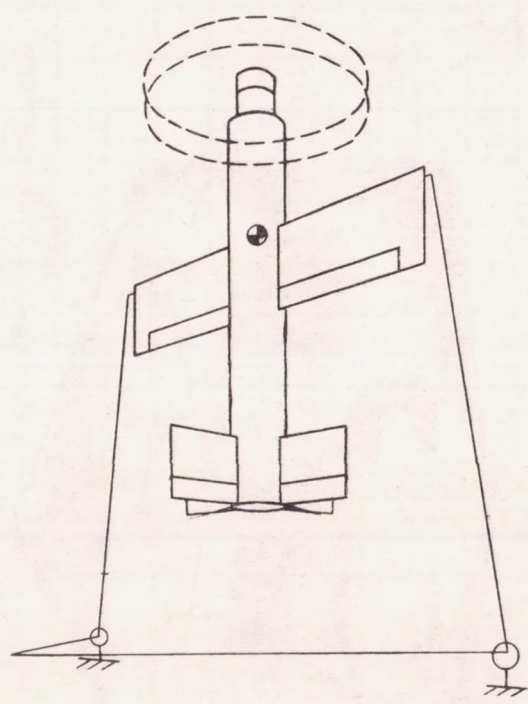

(b) Wing tethering.

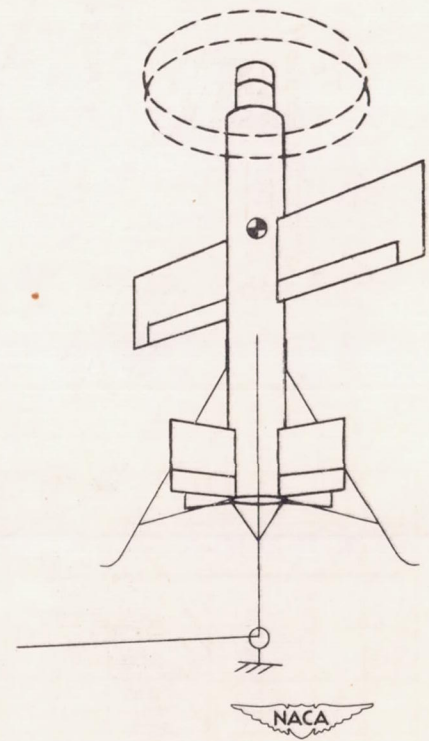

(c) Tail tethering.

Figure 5.- Tethering techniques used for landings.

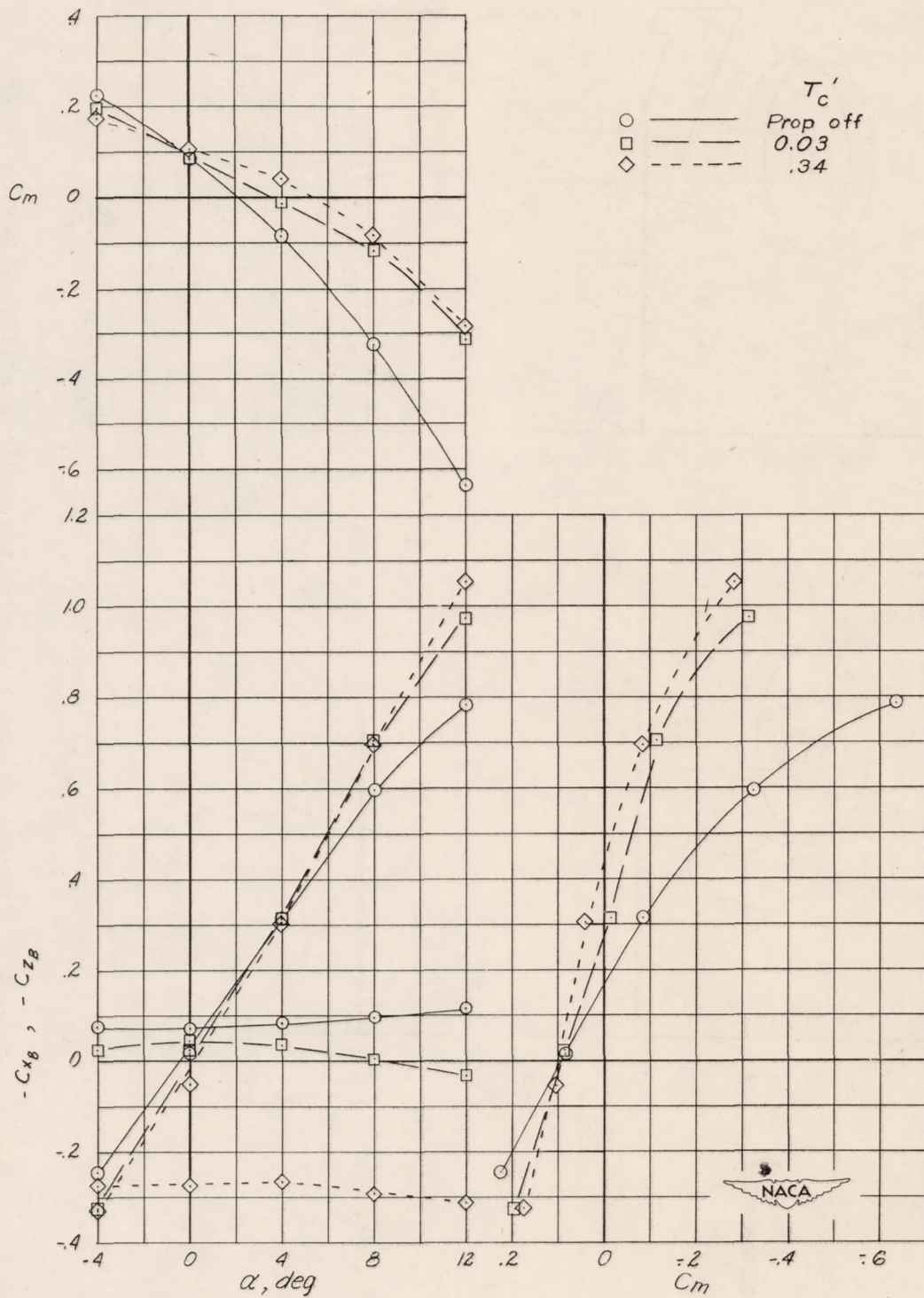
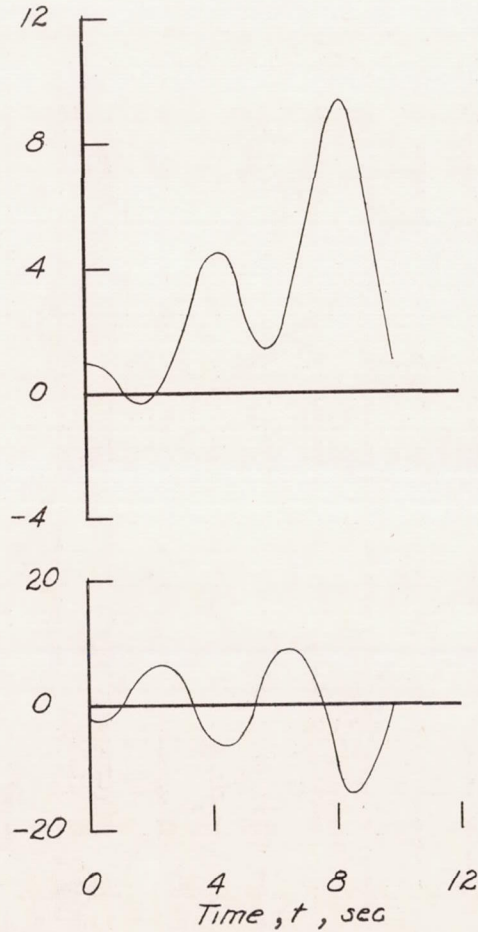
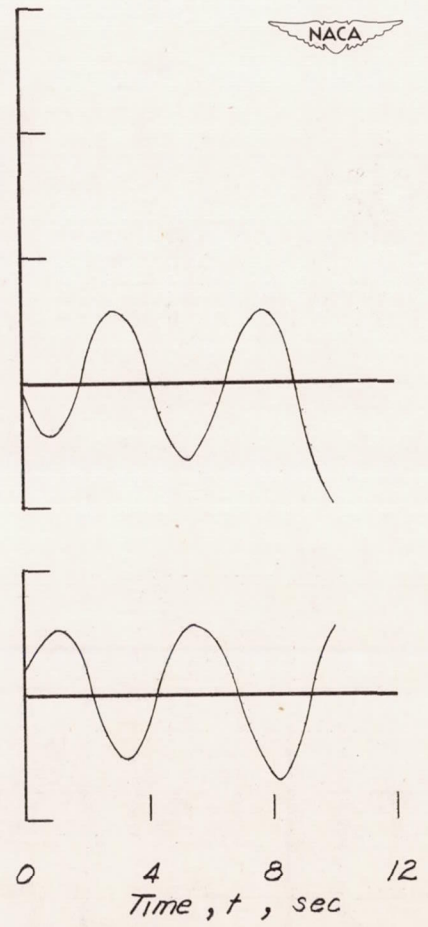
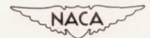

Figure 6.- Normal-force, longitudinal-force, and pitching-moment characteristics of a vertically rising airplane model for various thrust coefficients. $\delta_e = 0^\circ$; center of gravity located at the leading edge of the wing.

Z , displacement, ft



(a) Without autopilot.



(b) With autopilot $\frac{\delta_e}{\theta} = 2$.

Figure 7.- Effect of the rate-gyro automatic stabilizing device on the pitching motions of the model.

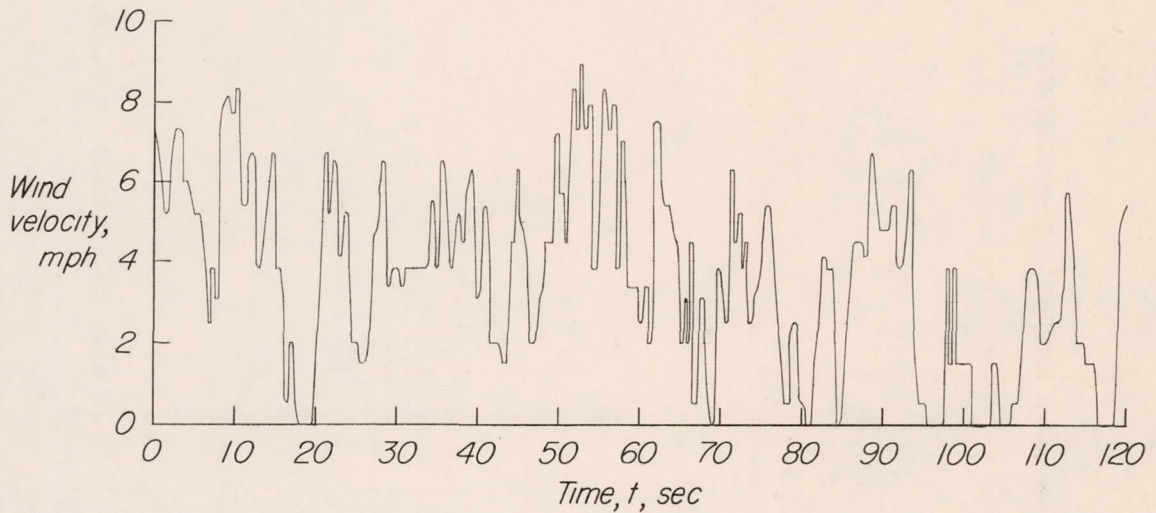

(a) Illustration of long-period velocity changes.

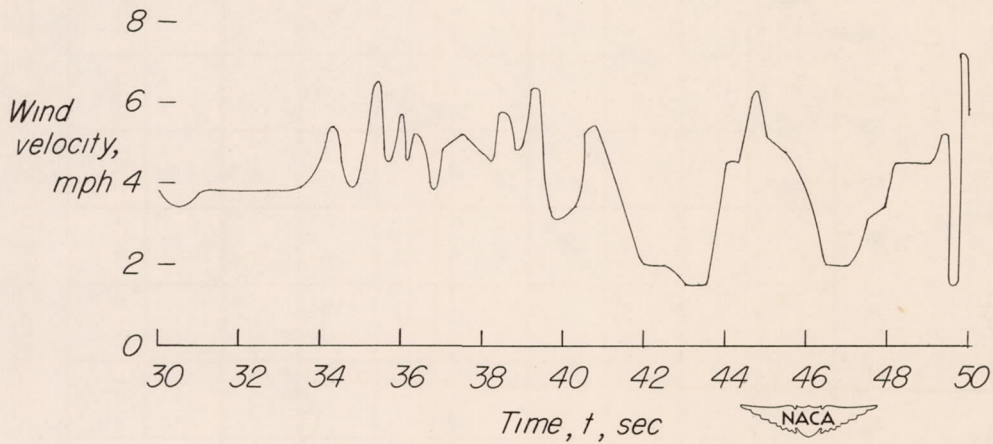

(b) Enlargement of part of (a) to illustrate the degree of turbulence.

Figure 8.- Illustration of the variation of the wind velocity with time in the return passage of the Langley full-scale tunnel.