

# RETURN FLUX EXPERIMENT

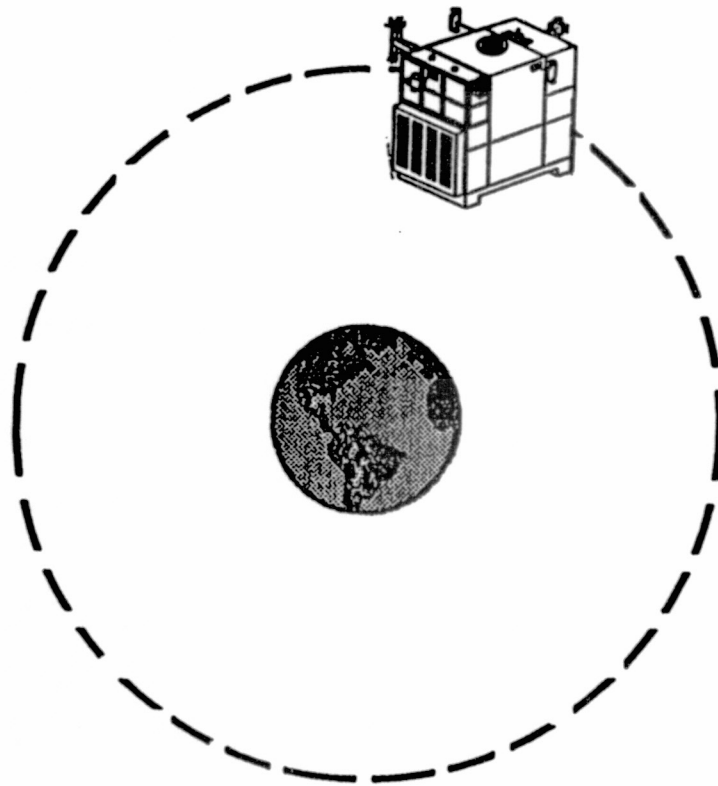

presented by  
**June L. Tveekrem**

**Flight Experiments  
Tech. Interchange Mtg.**

**October 7, 1992**



508  
159232  
P-1522

N93-28727



## BACKGROUND

NASA

- **All spacecraft emit molecules via outgassing, thruster plumes, vents, etc. Return flux is portion of those molecules that scatter from ambient atmosphere and return to the spacecraft.**
- **Return flux allows critical spacecraft surfaces to become contaminated even when there is no direct line of sight between the contamination source and the critical surface. LDEF data shows that contamination on LDEF surfaces could not have come entirely from direct flux – suggests significant return flux.**
- **Several computer models simulate return flux, but predictions have never been verified in orbit. Large uncertainties in predictions lead to overly conservative spacecraft design.**
- **Purpose of REFLEX is to fly a controlled experiment that can be directly compared with predictions from several models.**



## REFLEX OBJECTIVES

NASA

- 1) Measure the velocity, species, and density of the return flux molecules from an onboard noble gas source**
- 2) Characterize the ambient environment by measuring the velocity, species, and density of the ambient molecules**
- 3) Utilize REFLEX flight data for validating and updating available mass transport contamination models**
- 4) Measure the erosion rate of sample coatings due to reaction with ambient atomic oxygen**



# REFLEX AND SPARTAN SPACECRAFT

NASA

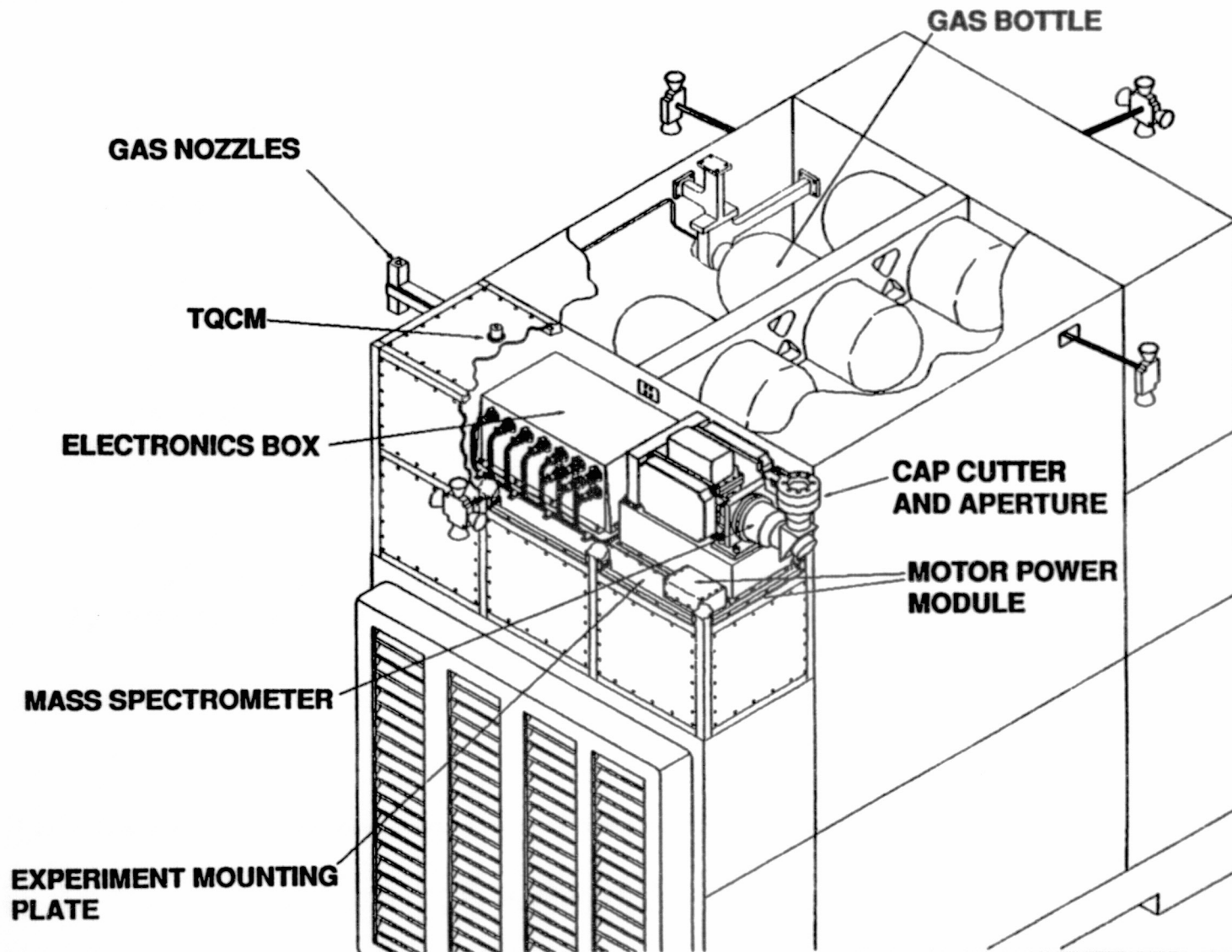





## REFLEX FEATURES

NASA

- **Inert, monatomic gases: simplifies modeling, avoids chemical reactions**
- **Mixture of two gases: allows measurement of cross-section dependence**
- **Nozzle shape is sonic orifice: easily machined, minimizes backflow and creep**
- **Two spacecraft attitudes (into ram and 90° to ram): allows limited measurement of angular dependence**
- **Mass spectrometer with energy analyzer: gives positive identification of scattered species, measures energy distribution**



## REFLEX SYSTEM



- **Weight:** 315 lb.
- **Volume:** 8.2 ft<sup>3</sup>
- **Power:** 2000 Watt·hrs
- **Duration:** 21 hours
- **Spacecraft:** Spartan, shared with 1 or 2 other expts.
- **Launch vcl:** Shuttle
- **Launch date:** April 1995 (STS-72)



# EXPERIMENTAL SCENARIO

NASA

ORBIT NUMBER	1 - 2	3 - 4	5 - 6	7 - 8	9 - 10	11 - 12	13 - 14
SPACECRAFT ATTITUDE*	RAM	RAM	RAM	RAM	90°	90°	90°
GAS NOZZLE SETTING	OFF	FLOW RATE OF 0.07 g/s	FLOW RATE OF 0.2 g/s	OFF	FLOW RATE OF 0.07 g/s	FLOW RATE OF 0.2 g/s	OFF

\*\*\*RAM\*\*= Mass spectrometer aperture and gas nozzle pointing into velocity vector

"90°" = Mass spectrometer and gas nozzle pointed perpendicular to velocity vector, with nozzle "upstream" of mass spectrometer



## MASS SPECTROMETER



Seabrook, Maryland

- Major components are energy analyzer, ion source, mass analyzer, detector.
- Energy analyzer distinguishes between ambient molecules (velocity 8 km/sec), return flux molecules (1 to 8 km/sec), and thermalized molecules (< 1 km/sec).
- Ion source ionizes molecules by electron impact.
- Mass analyzer is Mattauch-Herzog geometry, double focusing, with permanent magnet.
- Two types of detector used: Counting multipliers for current  $\approx 10^{-14}$  A or less, electrometer for current  $> 10^{-14}$  A.
- Range of mass spectrometer is 4 to 180 amu in mass, nine orders of magnitude in counts.

# REFLEX MASS SPECTROMETER SCHEMATIC

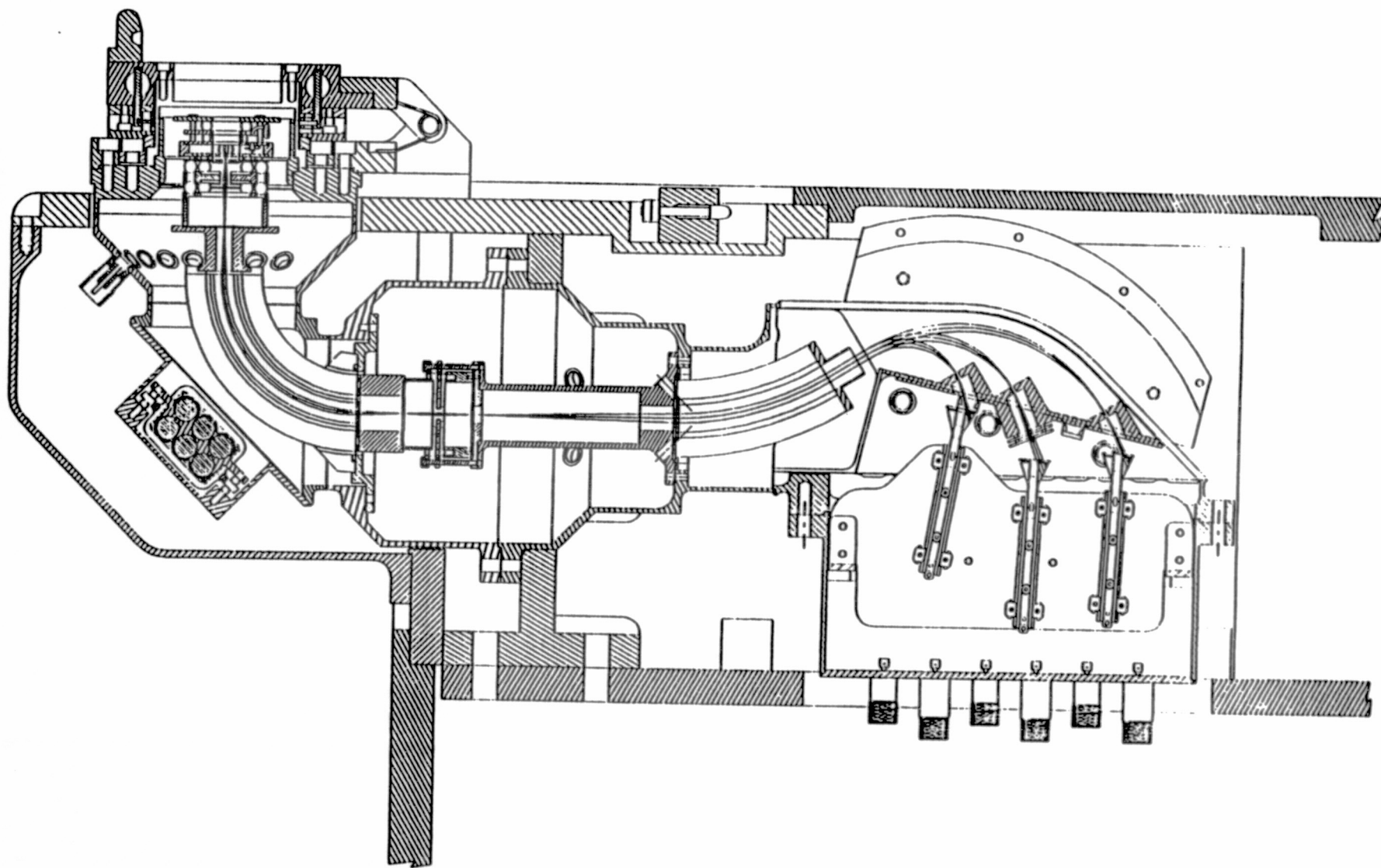



## DATA ANALYSIS

NASA

### Comparison With MOLFLUX Model

- **MOLFLUX Does Not Calculate Molecular Velocity (Energy).**
- **Therefore, Must Integrate Out Energy Dependence of Mass Spectrometer Data.**
- **Compare Observed Total Fluxes of Neon and Krypton to Model Predictions.**



## DATA ANALYSIS

NASA

### Comparison With ISEM Model

- **ISEM Predicts Flux Versus Species, Like MOLFLUX, so Can Make the Same Comparison as for MOLFLUX.**
- **Currently, ISEM Also Predicts *Average* Molecular Velocity for Each Species. Plan to Average the Mass Spectrometer Energy Data to Compare With This Prediction.**
- **In Process of Modifying ISEM to Give Velocity *Distribution*, i.e., Flux Versus Velocity, for Each Species. Then Can Compare Model Predictions to Mass Spectrometer Output.**





# COMPOSITION OF MOLECULAR FLUX INCIDENT ON REFLEX SPECTROMETER

NASA

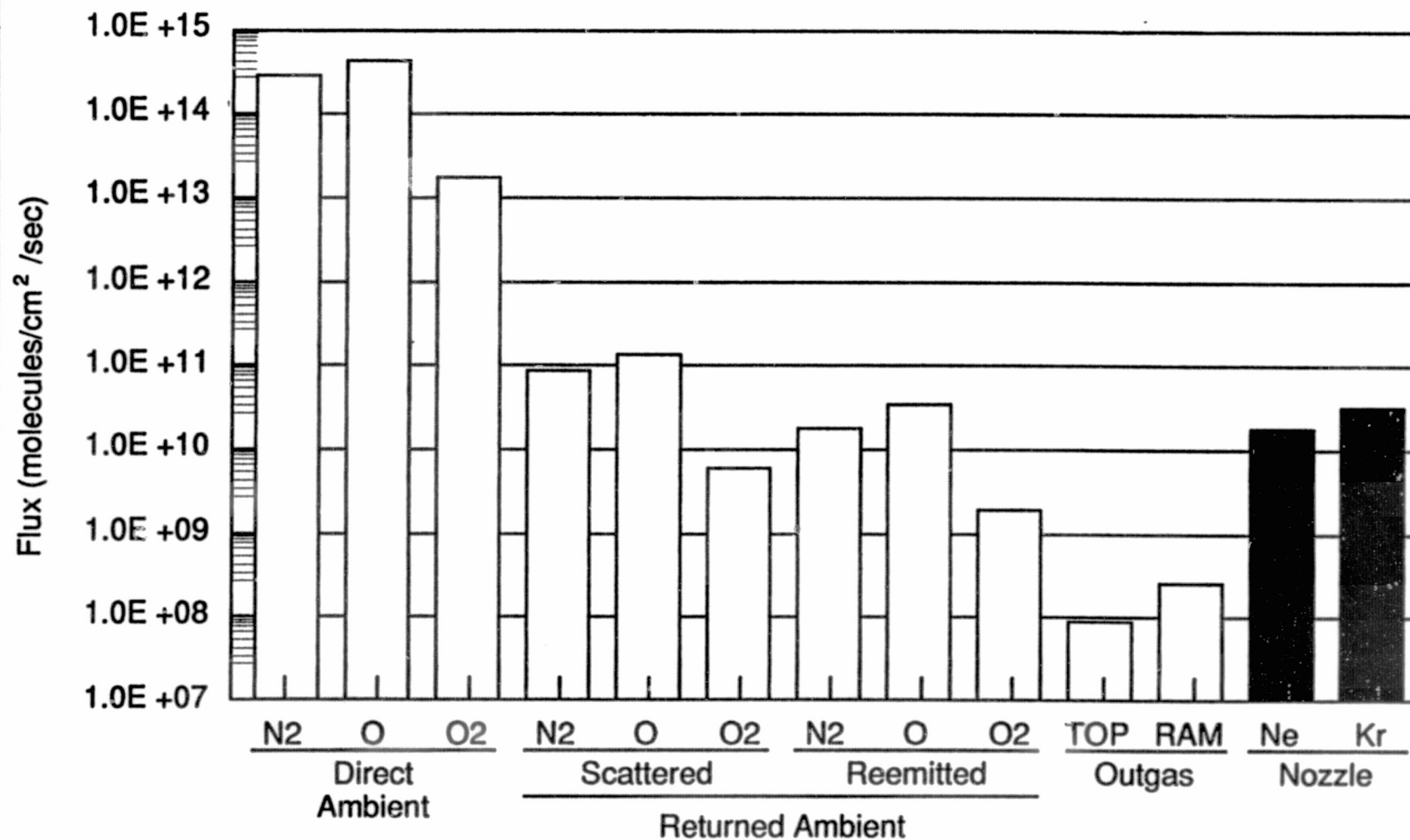



# MOLECULAR VELOCITY DISTRIBUTION

NASA

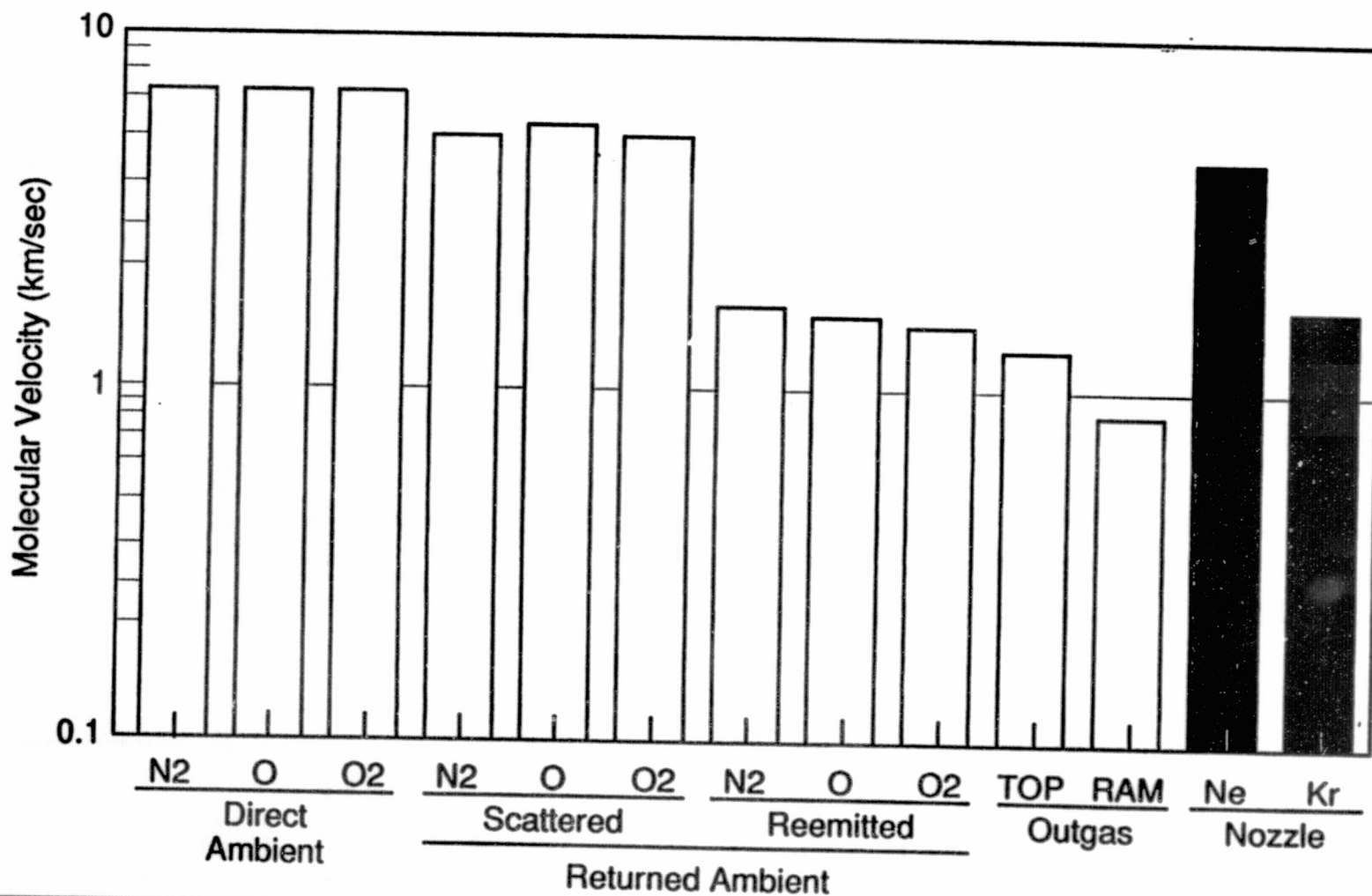



# IMPACT OF ACS FIRINGS ON INCIDENT FLUX OF REFLEX SPECTROMETER

NASA

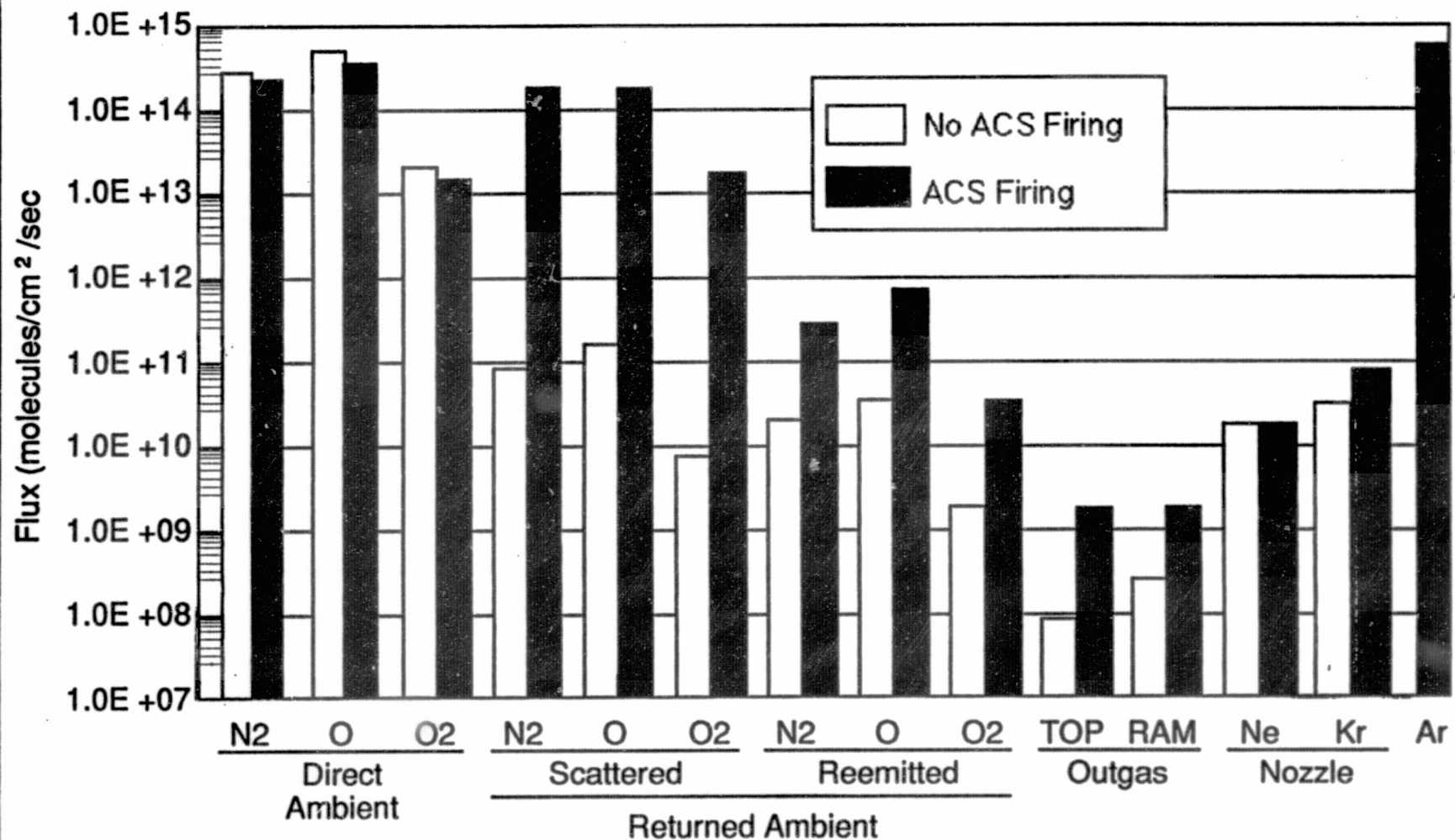



## SUMMARY

NASA

- **REFLEX is a controlled experiment to quantify the return flux effect.**
- **Return flux is measured by releasing a Neon/Krypton gas mixture at a known rate and using a mass spectrometer to detect molecules which "return" to the spacecraft.**
- **Preliminary modeling has shown that there is enough return flux signal, that the Spartan ACS will not interfere with the measurements, and that it will be possible to directly compare model predictions to the flight data.**
- **REFLEX will fly on a Spartan with 1 or 2 other (TBD) experiments.**
- **Launch is scheduled for April 1995.**