

S. 19-33

159223

1-10

N93- 28718

u 7

**Sodium Sulfur Technology  
Program  
NaSTEC**

**Lt Bob Highley, PL/VTPC**

**W. Andrew Somerville,  
Aerospace Corp.**



The Phillips Laboratory Conventional Space Power Branch is responsible research and development of solar power generation, power management and distribution, and energy storage systems for the Air Force. Some of the technologies currently being investigated are thin film and multi-band gap solar cells, polymer based cells, and sodium sulfur technology cells. The NaSTEC program focuses on developing currently available sodium sulfur cells for use in space applications and investigating the operational parameters of the cells.

**NaSTEC**  
**Sodium Sulfur Technology Program**  
**Program Goals**



**The goals of the NaSTEC program pertain to Na|S technology from US and UK vendors and will:**

- 1. Determine the operational parameters and verify safety limits of Na|S technology battery cells.**
- 2. Test long term zero-g operation.**
- 3. Create a life test database**

**These efforts will ultimately make technology transfer possible for Na|S, thus enhancing current missions and enabling future missions.**

The NaSTEC program will test cell samples from US and UK vendors to establish parameters of state of the art cells. The US cells offer high energy density as compared to standard NiH<sub>2</sub> cells, with a higher risk in operation. Cells from the UK offer a lower energy density than US cells, but with a higher reliability. The program will evaluate the pros and cons of both systems with regard to the goals outlined above and this information will be used to design advanced power systems for current and future missions.

# NaSTEC Sodium Sulfur Technology Program Approach



The program is divided into three phases:

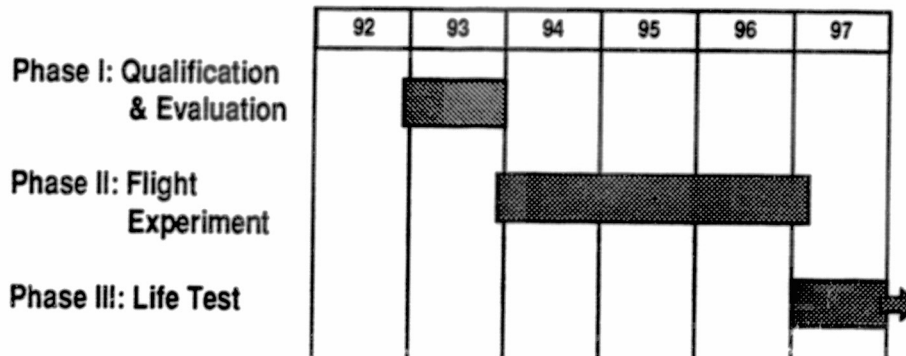

NaSTEC is comprised of three phases, each phase investigates a different aspect of cell research. Phase I concentrates on normal operational parameters and the upper and lower limits of both cell systems. Phase II will determine the effects zero-g, both immediate and long-term effects. Phase III will place a large population of NaS cells on extended life cycle test to build a database of cell operational data. Each of these phases is a self-sufficient program, but is designed to complement the other programs. This allows for flexibility in program planning and program management.

**NaSTEC**  
**Sodium Sulfur Technology Program**  
**Phase I : Testing**



**The purpose of Phase I is to:**

**Determine normal operational parameters of Na|S cells**

**Establish safety parameters for Na|S cells**

**Develop an understanding of failure modes and internal operation of Na|S cells**

**Research is to be performed by government agencies**

**Phillips Laboratory, Conventional Space Power**

**Sandia National Laboratory, Storage Batteries Div.**

**Naval Surface Warfare Center, Crane Div.**

**This phase will produce an unbiased evaluation of both US and UK technologies**

Phase I will test NaS cells both under normal operating conditions, and under extreme operating conditions. The results of the tests will give power system engineers more information about NaS cells and how to incorporate them into their power systems. The tests will give more insight into the failure mechanisms of NaS cells and operating procedures that will optimize cell performance. The tests are to be performed at two independent test facilities, Sandia National Laboratory, and Naval Surface Warfare Center, Crane Division. These government facilities ensure a unbiased evaluation of the two systems and expertise in the area. This phase should last one to one and a half years to produce the final results.

**NaSTEC**  
**Sodium Sulfur Technology Program**  
**Phase I : Testing**



<b>Life Testing:</b>	<b>Create a database of cell cycle data (C)</b>	<b>Overdischarge:</b>	<b>Discharge cells past cutoff voltage and observe cell behavior (C)</b>
<b>Freeze/Thaw:</b>	<b>Determine optimum freeze/thaw profile (S)</b>	<b>High Rate C/D:</b>	<b>Determine the rate capability of the cells (C)</b>
<b>Mech. Fract&amp; Operation:</b>	<b>Simulate shipping damage &amp; subsequent operation (S)</b>	<b>Short Circuit:</b>	<b>Observe cell behavior during a short circuit condition (S)</b>
<b>Overcharge:</b>	<b>Charge cells past cutoff voltage and observe cell behavior (C)</b>	<b>Overtemperature:</b>	<b>Determine the temperature limits of the cells (S)</b>
		<b>Vibrational Testing:</b>	<b>Evaluate Na/S cells' hot launch capability (S)</b>

(C)=Crane

(S)=Sandia

The tests have been designed to examine all aspects of cell operation with a minimum of duplication while maintaining statistical reliability of the data. Each facility will perform tests that best suit their particular capabilities. Each of the tests simulate some of the situations that the NaS cells might see in space, both normal and accidental. The goal of each test is outlined above and individual test plans will be formulated by the test facilities.

**NaSTEC**  
**Sodium Sulfur Technology Program**  
**Phase II : Flight Experiment**



**The Sodium Sulfur Technology (NaSTEC) Flight Experiment will verify zero-g operation and evaluate NaS Battery performance.**

**NaSTEC will fly both US and UK NaS cell technology.**

**NaSTEC will operate a NaS cell module in zero-g with a simulated GEO cycling regime.**

**Verify electrode material transport.**

**Validate wicking design.**

**Evaluate zero-g impact on operation.**

**Evaluate thermal characteristics.**

Phase II is the heart of the NaSTEC program. The flight experiment is designed to verify the zero-g operation of NaS cells and observe any effect on battery performance. This experiment will fly both US and UK cells for complementary testing in Phases I and III. Some of the concerns associated with zero-g operations of NaS cells are with the electrode material transport in the reactive zones of the cells, zero-g degradation of cell performance over a long period of time, and thermal control of the cells without major impact on the rest of the space craft. This will be accomplished by cycling the cells in a simulated GEO cycling regime and analyzing the data as it is collected. The mission has a one year requirement with a three year goal.

**NaSTEC**  
**Sodium Sulfur Technology Program**  
**Phase II : Approach**



**The Flight Experiment will be designed with several factors in mind:**

**Weight and volume to be kept at a minimum**

**Power and data requirements reduced to moderate levels using charge scheduling and low data rates**

**Keep costs down by using Class B and/or Proto-Qual hardware and reducing redundancy to a minimum acceptable level**

**This approach will produce preliminary data concerning the operation of Na|S in zero-g, thus opening the door for further research and use as prime power on many missions**

Experiment design is driven by economy in weight, volume, cost, and power requirements. Construction of the experiment will be contracted out, with the design developed through close interaction between the contractor and the experimenter. Weight and volume will be economized through careful planning of materials used and the structures required. Current capabilities of data collection and recording are more than sufficient for handling the requirements of the experiment, but to cost low on these components, data rates will be reduced to a minimum acceptable level. Power consumption of the experiment can be excessive, if not controlled. The requirement of the experiment package will be reduced through the use of a unique charge control system. The US and UK cells will be divided into two electrically separate cell packs. During cycling, one pack will be discharging and the other charging, using the excess power of the first pack. There will be some power drawn from the satellite bus to account for the losses in wiring, heater power, controller power, and any loss of capacity in either cell pack. This arrangement will help with thermal management and hardware requirements. As NaS cells are discharging, they give off heat. This heat is absorbed by the charging cells to maintain operating temperature with minimum heater power. Hardware is reduced by eliminating the need for external thermal management, and load radiators. All this will help reduce the cost of the experiment. The components to be used in the experiment will be Class B parts and possibly some proto-qual type parts. This may affect the weight, volume, and power budget, but savings in cost will compensate.

# NaSTEC

## Sodium Sulfur Technology Program

### Phase II : Description

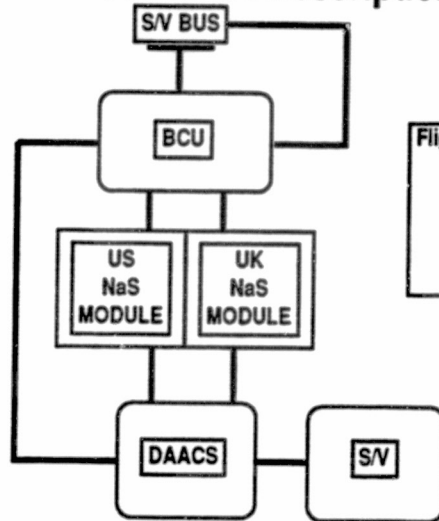

#### Flight Test Unit Requirements

Orbit:	None
Weight:	27 kg
Volume:	0.1 cubic meters
Power:	80 watts(avg)

The exact requirements of the experiment have not been formalized, but the values listed above are close estimations. The small size and volume will allow for easy incorporation of the experiment into a wide variety of satellites. All efforts will be made to make the interfaces as generic as possible, as to be compatible with the system bus. The simulated cycling regime will make the experiment compatible with any actual orbit the host satellite may be in, though the only hard requirement is that the satellite must not be a spinner or a tumbler. This would induce centripetal force that would affect cell performance, and we would not be able to evaluate the cell's zero-g capability.



**NaSTEC**  
**Sodium Sulfur Technology Program**  
**Phase III Life Test**



**Phase III will commence after operation of NaS cell technology has been demonstrated in zero-g and will develop into a large scale life cycle test**

**Data from the test will be compiled into a database which will then be used by system engineers to design satellite power systems**

**Large scale life test will also include experimental accelerated cycle profiles**

**Test profiles will include:**

**GEO Cycling**

**Pulse Testing**

**LEO Cycling**

**Accelerated Cycling**

**User Defined Profiles**

After the flight experiment is operational on orbit for several months, and initial cell operation is proven, a large scale cycling program will be started. This test will generate data that will be used by power system engineers to design power systems for satellites. The tests will look at all types of operating profiles including accelerated cycling, LEO cycling, GEO cycling, pulse testing, and user defined profiles. The test will last over five years with the possibility of becoming a permanent test. The data generated will be analyzed with respect to the data obtained from the flight experiment with regard to zero-g effects on cell performance. The data then will be compiled into a database for easy manipulation and access. This data will be accessible at first to governmental agencies and to others on special agreements between the requesting organization, the testing organization, and the cell vendors.

**NaSTEC  
Sodium Sulfur Technology Program  
Conclusions**



**This program is vital to the transfer of NaS technology to the end user and Phases I and II must be completed by FY97 and Phase III started**

**Knowledge gained through this program will be used to design better power systems for satellites**

**Each phase can stand alone if necessary, but not recommended**

**Total cost of the program is estimated to be \$10-\$15 million for all phases**

In order for NaS technology to become acceptable and available to the end user by FY 97, the goals of the NaSTEC program must be completed. NaSTEC will perform this task by completing Phases I and II, and by starting Phase III. NaS technology is at a point at which tech transfer can be made possible and power systems will be made more efficient through the use of NaS cells.