

340-61  
150510

N93-25601

P-9

## INTEGRATION OF DESIGN, THERMAL, STRUCTURAL AND OPTICAL ANALYSIS, INCLUDING THERMAL ANIMATION

Ruth M. Amundsen  
NASA Langley Research Center  
Hampton, VA 23681

### ABSTRACT

In many industries there has recently been a concerted movement toward "quality management" and the issue of how to accomplish work more efficiently. Part of this effort is focused on concurrent engineering; the idea of integrating the design and analysis processes so that they are not separate, sequential processes (often involving design rework due to analytical findings) but instead form an integrated system with smooth transfers of information. Presented herein are several specific examples of concurrent engineering methods being carried out at Langley Research Center (LaRC): integration of thermal, structural and optical analyses to predict changes in optical performance based on thermal and structural effects; integration of the CAD design process with thermal and structural analyses; and integration of analysis and presentation by animating the thermal response of a system as an active color map -- a highly effective visual indication of heat flow.

### INTRODUCTION

Efficiency and accuracy in analytical modeling can be increased substantially by the integration of design and analysis -- a process known as "concurrent engineering." This approach is being used in many areas to minimize the time spent in analysis without sacrificing quality. In particular, analysis effort can be minimized by utilizing the model already developed by a designer on a CAD system. Also, models and results can be transferred among analysts electronically, to avoid repetitive development of models or manual input of results.

Electronic integration of design and analysis processes was achieved and refined during the development of an optical bench for a laser-based aerospace experiment. One of the driving requirements for any complex optical system is its alignment stability under all conditions. Accurate predictions of optical bench or test bed deflections are necessary to calculate beam paths and determine optical performance. This is especially true in design of aerospace instruments, but can also apply to manufacturing or laboratory processes which use complex or high-precision optical trains. Another requirement that is increasingly demanded of any analysis process is to do it faster and better; create a more streamlined process and include all known variables to produce the best possible predictions. These goals can be accomplished by using an integrated process to accomplish design and all analyses.

The heart of the concurrent engineering process described here is the use of a single integrated model for thermal and structural analysis of a high-precision system, in this case an optical bench. The deflections of the optical bench due to structural loads can be calculated by applying the appropriate structural software package to a solid geometry model. The thermal response of the optical bench is determined by translating the same model to the thermal analysis software package. The predicted temperatures are used to calculate thermally-driven distortions. This method allows an exact calculation of the optical bench or test bed deflection due to complex thermal distributions in combination with various structural loading conditions. These calculated deflections are then used to automatically modify an optical analysis model. The change in optical performance due to given thermal and structural loads can then be determined. Designs can be optimized for peak optical performance. The analytical model can be taken directly from the design software, which eliminates an additional point for extra labor and potential error. The integrated nature of the process streamlines the modeling and analysis procedure as well as ensuring model continuity between design, thermal and structural analyses. Described herein are methods

to build an analytical model directly from the CAD model of the designed part, use the same model for structural and thermal analyses, and use the results of these analyses for the optical analysis to predict final performance.

This integrated analysis process has been built around software that was already in use by designers and analysts at NASA Langley Research Center. The PATRAN<sup>®</sup> solid modeling / finite element package is central to this process, since it was already in common use at LaRC. Most of the integration and interface steps described here are also possible with other packages, although certain of the translators were developed or modified for use with these specific software packages.

### INTERFACE BETWEEN DESIGN AND ANALYSIS SOFTWARE

The design software currently being used in this process is Pro-Engineer<sup>®</sup>. A part is completely designed in Pro-Engineer, which produces a three-dimensional model of the part as well as all of the fabrication drawings. A Pro-Engineer solid shaded model of a complex assembly is shown in Figure 1. This example assembly is a laser reference cavity which is mounted on an optical bench. There are two basic methods available to translate from Pro-Engineer CAD software to the PATRAN 2.5 solid modeling software. Both of these methods have been used to produce viable models. One is to mesh the solid geometry of the part in Pro-Engineer and translate that mesh to PATRAN. The disadvantages to this method are: only the mesh is transferred, not the underlying solid geometry, so the geometry and mesh cannot be changed in PATRAN; and the mesh is limited to only tetrahedral or triangular elements. The second method is to transfer the part from Pro-Engineer to an IGES file, which is a standard graphics format, and read this file into PATRAN using the CADPAT translator. This translates the phase I (underlying) geometry, but only in the form of surfaces and lines, not PATRAN's solid geometry elements called hyperpatches. Thus the analyst must still define hyperpatches based on the geometry defined by the translated surfaces. This can actually be helpful as the analyst can choose to ignore details such as bolt holes in constructing the analytical model. The disadvantages to this method are this re-creation of the solid form from the transferred surfaces (which only applies when the part being transferred is a solid rather than plate elements), and also that during translation of an assembly of parts, the orientation of the individual parts is lost and the assembly must be reconstructed from the components.

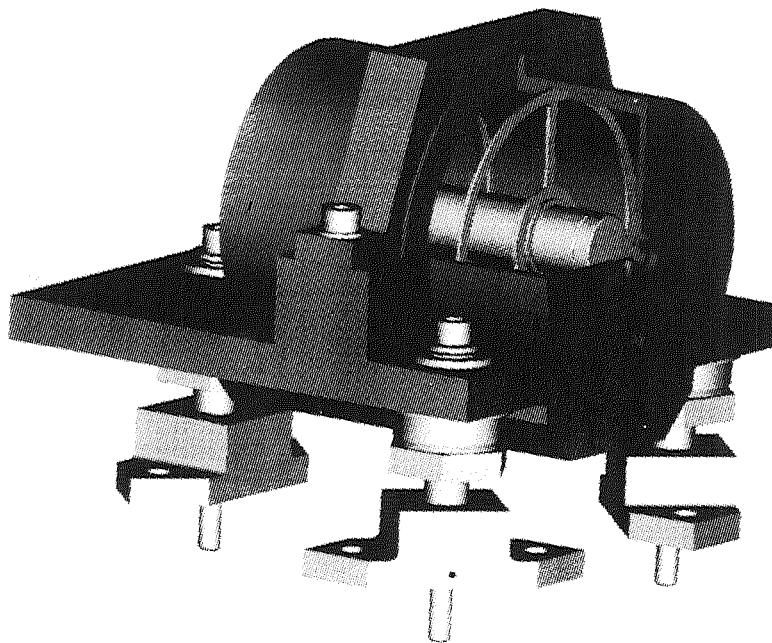
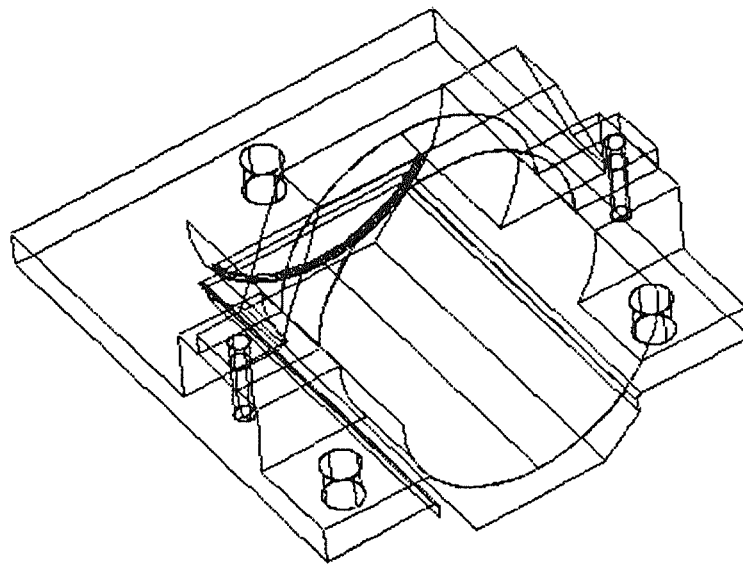
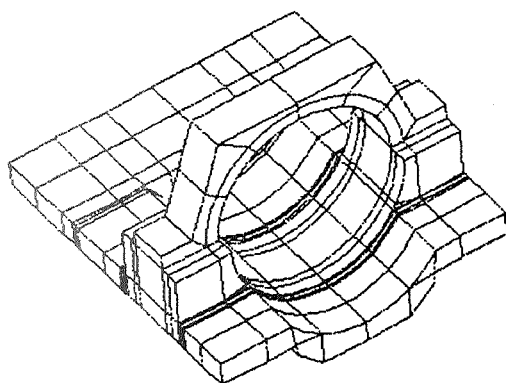

Figure 1. Laser reference cavity as designed and portrayed in Pro-Engineer

The best method in terms of the current integration process, for most parts, is to transfer a part into PATRAN by saving the 3-D part design as an IGES file. This IGES file is read into PATRAN as lines and surfaces which define the edges of the part; three-dimensional hyperpatches are then created to fill in the part. This method allows the analyst to mesh the part with the optimum element type, perform runs with different meshings, and easily alter the underlying geometry and analyze the effect of the change. Shown is an example of the mount portion of the reference cavity which was brought in as an IGES file (Figure 2) and then filled in with hyperpatches (Figure 3).



**Figure 2. Mount part imported to PATRAN from ProEngineer through IGES file**



**(a) Shown as elements**

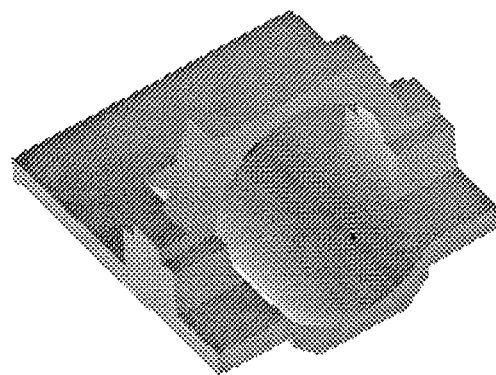

**(b) Shown as solid shaded part**

**Figure 3. Mount part with solid elements created in PATRAN**

This design/analysis integration has several benefits. In terms of streamlining the process, there is much less work to be done by the analyst since the majority of the geometry is imported automatically. The entire process of taking dimensions from a design drawing and manually building up the geometry is eliminated. Also, the analyst is automatically working with the most current version of the design. In terms of improving the results, the fact that the human interface of re-entering the dimensions is eliminated will lessen the probability of errors in

the model. Also, geometries that are difficult to model and would perhaps be approximated are automatically translated exactly. In some cases, however, the CAD model actually has too much detail for the analyst; in these instances the model can be simplified after the transfer.

There will be an increase in capability with the releases of future versions of Pro-Engineer and PATRAN. First, a mesh of an entire assembly, rather than single parts, can be created in Pro-Engineer and sent to PATRAN. Also, the IGES file method can be used on an assembly, and the positional information of one component relative to others will be maintained. In PATRAN-3 the phase I solid geometry will not be required, so that the analyst could create elements directly from the imported CAD geometry. PDA Engineering will be adding an option to allow the underlying solid geometry to be imported from Pro-Engineer to one of the later releases of PATRAN-3. This would mean that the entire solid model, including hyperpatches, would be available to the analyst in PATRAN. As the interface improves with future versions of the programs, it will also be possible to automatically import and export changes to the design that are made either by the designer or by the analyst. These benefits would be even more striking in an industrial process, where many more designs are produced and analyzed than is common in the aerospace industry.

### INTERFACE BETWEEN THERMAL AND STRUCTURAL ANALYSIS

The translations between structural and thermal analytical models are already built into the PATRAN system. However, there are a few methods that make this type of translation easier and more effective. The model can be built in PATRAN by either analyst; however there must be communication between the analysts before the model is built, so that the final model will have a structure and level of detail appropriate for both analyses. One unique aspect of the work described herein is that the structural and thermal analysts determined together what method would be best for both of them in modeling certain parts, before the model was developed. A requirement on the thermal side, which must be maintained in the model in order for it to be useful for the thermal analyst, is that between every pair of connected elements, all corner nodes must be identical. Also, the best translation to a thermal model is currently achieved by using solid elements rather than plate elements in most cases. Many of the connections between solids and plates, and plates-to-plates, that are correct for the structural analyst, do not work correctly for the thermal analyst. In order for each analyst to be able to easily create their own mesh, or use the same mesh, the phase I geometry must meet the requirements of both analysts.

The PATRAN model is translated to SINDA-85, a finite difference thermal analyzer, using the PATSIN translator. This SINDA-85 model is used to perform thermal analysis, with some modifications such as adding power sources. The structural analysis can be performed either in P/FEA (a software package that directly interfaces with PATRAN) or after translation to NASTRAN or EAL (Engineering Analysis Language). The analysts sometimes desire different levels of detail; thermal analysis commonly uses a lower level of detail than structural analysis. In that case, an identical PATRAN phase I geometry of patches and hyperpatches is still used and each analyst can create their own mesh. The thermal results from SINDA can be translated using the SINPAT translator into temperature data files which are read by PATRAN. These temperatures can be used to impose accurate thermal loads on the structural model regardless of whether the meshing is the same, as long as the phase I geometry has not been changed. Shown in Figure 4 are examples of models which were built and meshed by one analyst and used by both. This has also been done with a model using two different meshings and element numbering schemes; the interpolated values imported from one model to another were checked and found to be correct.

The only change that must be made to alter the model between use by the thermal and structural analysts is a re-definition of the material properties, usually a five to ten minute task. The material identification is maintained through the transfer; only the actual material properties need be re-input. Unfortunately the material properties are exclusive, so that each time the PATRAN model is transferred between analysts, the material properties must be redefined. This is not normally a problem since the transfer is done only once. Also, improvements slated for PATRAN version 3 will do away with this concern.

The easiest way to use the nodes and conductors created by PATSIN is to separate them into files which are called into the SINDA model using an INCLUDE statement. Thus the SINDA model can contain other data such

as heating arrays; if there is a change to the PATRAN model it will only affect the included files, with the main SINDA model left unchanged. Also, the output of PATSIN is often quite bulky, which would make editing of the full SINDA model more difficult. Using included files limits the size of the SINDA model file, and allows several different SINDA files to reference the same node and conductor files.

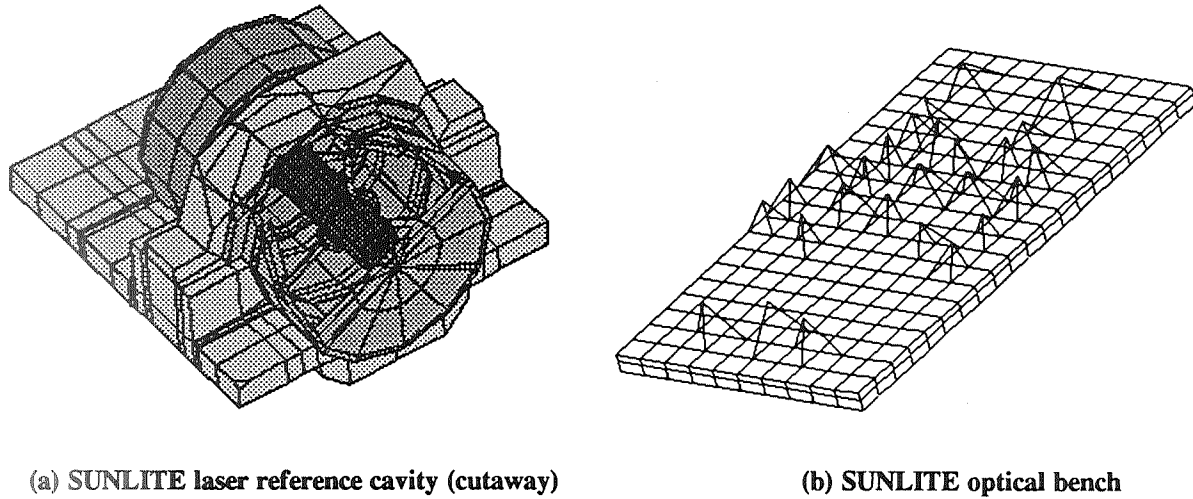

Figure 4. PATRAN models used for both thermal and structural analysis

The thermal results, either from a steady state analysis or from time steps in a transient run, are saved in a text output file. This file is operated on by the translator SINPAT to produce element and nodal temperature files that can be read by PATRAN. These files can be read directly into PATRAN, and the thermal results mapped onto the model geometry. This is shown in Figure 5 with a thermal map displayed on the laser reference cavity.

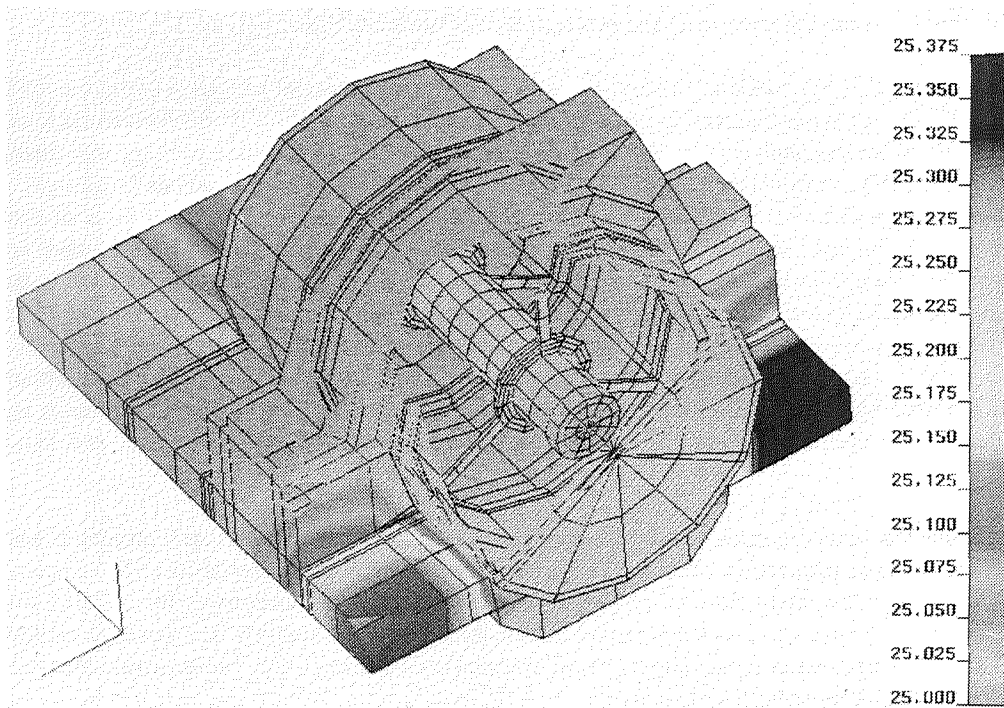

Figure 5. Map of thermal distribution (in degrees C) on laser reference cavity in PATRAN

In order to use the nodal temperatures as actual thermal loads rather than only for display, the files must be run through a program called READER which translates the text files to binary. The results can be interpolated onto the structural model using a built-in utility of PATRAN (TEMP, ADD/INT). The thermal results, imported into the PATRAN model, can be used in the structural analysis software to calculate thermally-driven stresses and deflections based on the predicted temperature distribution. These thermal stresses can be summed with any load-driven stresses, to produce a total reaction of the system to the environmental constraints.

## INTERFACE BETWEEN STRUCTURAL AND OPTICAL ANALYSIS

Most optical models start with the assumption that the system is aligned and at rest. The optical analyst inputs surfaces, sources and objects at their designed location, and determines the performance of the system. The optical code currently used by analysts at LaRC is CODE-V<sup>®</sup>. During actual operation of the optical system, there will often be factors that cause distortions to the perfectly aligned system. In the case of an optical bench which has optical components mounted on it, there can be thermal gradients across the bench which will cause minute warping of the bench, but which result in significant distortion of the optical system from its baseline aligned performance. There can also be structural loads imposed which cause deflections, and both the thermal and mechanical loading environment can be changing with time. There is an existing translator that will look at the deformation of a single optical element such as a lens in NASTRAN, and translate the appropriate information to CODE-V to determine the distorted lens performance. However, for the optical bench structure, a method was needed to look at changes in the overall performance based on distortions of the entire bench, not only a single element.

The method that has been developed starts with writing an output file of nodal deflections from the structural analysis software. The deflections can be due to thermal, structural or any other loading conditions. A relational file is developed for that model which relates the nodes in the PATRAN model to the optical surfaces in the CODE-V model. This relational file can be used for any translations of results from that PATRAN model to CODE-V. Translation software (temporarily named BENCH) was developed to read the deflection file, the relational file, and a copy of the undeflected CODE-V model. It produces a new CODE-V model which has new positions and angles for the optical elements based on summing the predicted deflections and the original positions of the elements. It also adds a title to the CODE-V model based on the deflection case that was run and augmented by user input. For a single optical bench there is only one PATRAN model, but there can be a separate CODE-V model for each optical path. The translation must be run for each optical path for which deflection analysis is desired. CODE-V can then be run on the new model, and optical performance based on the distorted bench is predicted. The translation can be run for a series of time steps, using deflection results files for each time step, to predict the performance of the system as a function of time. Figure 6 demonstrates the steps of this process pictorially by showing the temperature distribution on an optical bench (a), a map of the thermally-driven distortions from this distribution (b), a map of distortions due to structural loading (c), and a map of the combined distortions (d). These combined distortions, consisting of six numbers for each optical surface (rotations and translations in each of three axes), were written to the deflection results file. This file was used to modify the CODE-V optical model, and yielded the predicted performance of the system under these deflections. Development of a users' manual for this translation software is currently underway.

## THERMAL ANIMATION

Structural analysts commonly use animation in their presentation of results. Animation of mode shapes or predicted deflection patterns is a vivid method of capturing and conveying all the necessary information. This is done less often with thermal analysis, with the result that many viewers have a less concrete idea of the physical progression of temperatures or heat flows. A visual animation of the thermal map, in color, gives a very effective representation of the physical transfer of heat.



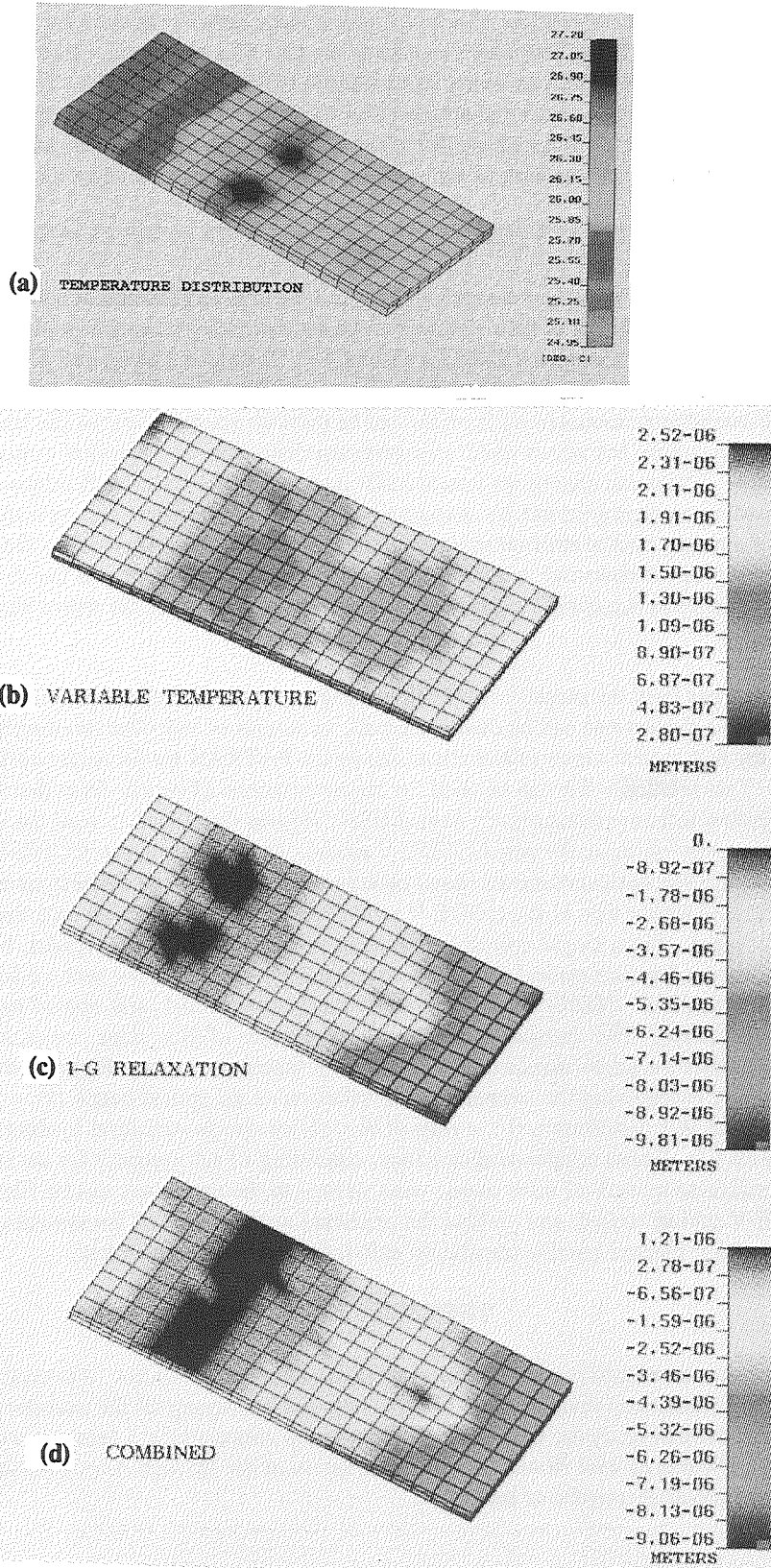

Figure 6. SUNLITE optical bench with progressive mappings: (a) thermal distribution, (b) thermally-driven deflections, (c) mechanical load-driven deflections, and (d) summed deflections

Animation of transient thermal results, in combination with an integrated structural-thermal model, is a very effective tool that has been utilized through PATRAN and its connection with SINDA. The temperatures of a part are mapped onto the geometry using a color scale. Color maps are generated for several sequential time steps. The mappings are viewed in a sequence that is run repeatedly on the screen. The progression of temperatures along the part as a function of time is observed as an animated color thermal map. This function is invaluable when evaluating the driving force behind a given reaction, and can also give an audience a much clearer understanding of the processes involved in a complex reaction. Cases can be recorded on video tape and used to demonstrate results to a larger audience. This function is also quite valuable to the analyst, as it provides a method for debugging the model and perhaps finding errors that would be time-consuming and tedious to find in any other way.

The specific method for performing this animation is to run SINDA with thermal output at all desired time steps. A virtual temperature (VTE) file must still exist from the PATSIN translation for the SINPAT translator to use in calculating nodal temperatures from element temperatures. Once SINPAT has created the nodal results files, the easiest way to set up an animation is to set up a PATRAN session file which reads in all of the frames. This avoids manual keying of three input lines per frame. The session file sets up the number of frames and the spectrum to be used. For each data frame, RUN, CONTOUR and RUN, HIDE commands are performed. The last line for the last frame must be typed in manually. After the last line is entered, the animation will begin running on the screen. The animation characteristics may be altered in real time using the animation menu. On 3-D workstations the part can be rotated on the screen during animation, so that thermal progressions on all sides of the part may be viewed.

#### FUTURE PLANS

Several improvements have been planned for this process in the future. The translation of bench distortions from NASTRAN to CODE-V could be integrated with the built-in capability of CODE-V to accept the distortions of a single optical element from NASTRAN to produce a complete prediction of the system performance. Also, a method could be developed to run all of the optical path translations in a model at one time. The entire process, from design software through thermal/structural analysis to optical performance, should be run on a simple system design to evaluate the efficiency of the entire technique.

The advent of PATRAN-3 should add many valuable features to the process, in terms of simplifying the CAD/analysis interface, upgrading the structural analysis flexibility, and improving the post-processing and display capabilities. Also, the greatly improved user-friendliness of version 3 may encourage more thermal analysts and CAD designers to integrate their work with the structural models. However, there may be a temporary set-back in that PATRAN-3 will probably not initially support the PATSIN translator. This lack of thermal support within version 3 will force the thermal analysts to continue using version 2.5 for at least some portion of their work, while the structural analysts shift to using version 3. It is not yet clear how much of an impact this will have on the integrated process, and how rapidly PDA will implement the SINDA interface in PATRAN-3.

#### CONCLUSIONS

The process that has been developed uses existing software and translators, along with some newly developed translators, to electronically link design with analysis, and to integrate several types of analysis. This allows an analyst to quickly develop a complex geometric model with much less time-consuming and repetitive labor, since the geometry is imported electronically. Since both the thermal and structural analyst can use the same model, the labor involved in creating an extra model is eliminated. With the use of an integrated model, the thermal gradients can be directly understood in terms of deflections, and presented with the other structural results. Transfer to the optical analysis model allows interpretation of the impact of worst-case environmental conditions on the optical performance. Without this, optical performance must be roughly estimated or calculated by manual input of worst-case deflections. Visual observation of the thermal dynamics of a system has been very useful in understanding and presenting the significant thermal forces in a system. This allows the analyst to concentrate



concentrate detail in the appropriate portions of the model and uncover errors that would otherwise be undetectable. All these improvements lead to better, faster and cheaper accomplishment of total system design.

Many of the described aspects of integration and animation have high potential for commercial and industrial applications. The integration between design and analysis can be used to streamline any mass-production application such as design and manufacture of automotive parts, machine equipment, or plastics fabrication. The integration between thermal, structural and optical analysis can be useful in any field which requires maintenance of close tolerances between optical components; examples are automated fabrication/assembly lines which use lasers for position measurement, scientific laboratories which use lasers for experimentation and measurement, and of course research and development centers such as LaRC in developing sensitive optical instruments for applications such as remote sensing of pollutants. The animation of thermal analyses can be of significant use in any field where understanding of thermal flow is critical. Examples include plastics manufacturing (such as molding and extrusion processes), automotive engine design, electronic design and fabrication, analysis of chemical reactions, and power plant design.

### ACKNOWLEDGEMENTS

The efforts of Kelly Smith in structural analysis, Steve Hughes in design, Maria Mitchum in software development, and Greg Herman, Alan Little and Andrew Cheng in optical analysis are gratefully acknowledged. The funding for this work was provided by the SUNLITE project.