



US005193929A

United States Patent [19]

[11] **Patent Number:** 5,193,929

Kahn

[45] **Date of Patent:** Mar. 16, 1993

[54] **METHOD AND APPARATUS FOR PRELOADING A JOINT BY REMOTELY OPERABLE MEANS**

[75] **Inventor:** Jon B. Kahn, League City, Tex.

[73] **Assignee:** The United States of America as represented by the Administrator of the National Aeronautics and Space Administration, Washington, D.C.

[21] **Appl. No.:** 892,072

[22] **Filed:** Jun. 1, 1992

[51] **Int. Cl.⁵** B25G 3/00

[52] **U.S. Cl.** 403/14; 403/404; 403/273; 403/321

[58] **Field of Search** 403/404, 273, 321, 14; 285/381, 422

[56] **References Cited**

U.S. PATENT DOCUMENTS

3,024,052	3/1962	Oliveau	403/321
4,297,779	11/1981	Melton et al.	29/446
4,489,964	12/1984	Kipp et al.	285/422
4,501,058	2/1985	Schutzler	285/381 X
4,753,465	6/1988	Dalby	292/32
5,024,549	6/1991	Dalby	403/404

Primary Examiner—Andrew V. Kundrat
Attorney, Agent, or Firm—Russell E. Schlorff; Guy M. Miller; Edward K. Fein

[57] **ABSTRACT**

Method and apparatus for joining structures, an active structure (10) and a passive structure (12), and imposing a tensile pre-load on the joint by a remotely operable mechanism comprising a heat contractible joining element (15). The method and apparatus include mounting on the structure (10) a probe shaft (15) of material which is transformable from an expanded length to a contracted length when heated to a specific temperature range. The shaft (15) is provided with a probe head (21) which is receivable in a receptacle opening (41) formed in the passive structure (12) when the active structure (10) is moved into engagement therewith by an appropriate manipulator mechanism. A latching system (45) mounted on the structure (12) adjacent to the receptacle opening (41) captures the probe head (21) when the probe head (21) is inserted a predetermined amount. A heating coil (26) on the shaft (15) is energizable by remote control for heating the shaft (15) to a temperature range which transforms the shaft (15) to its contracted length whereby a latching shoulder (24) thereof engages latching elements (47) of the latching system (45) and imposes a tensile preload on the structural joint. Provision is also made for manually adjusting the probe head (21) on the shaft (15) to allow for manual detachment of the structures (10,12) or manual preloading of the structural joint.

9 Claims, 3 Drawing Sheets

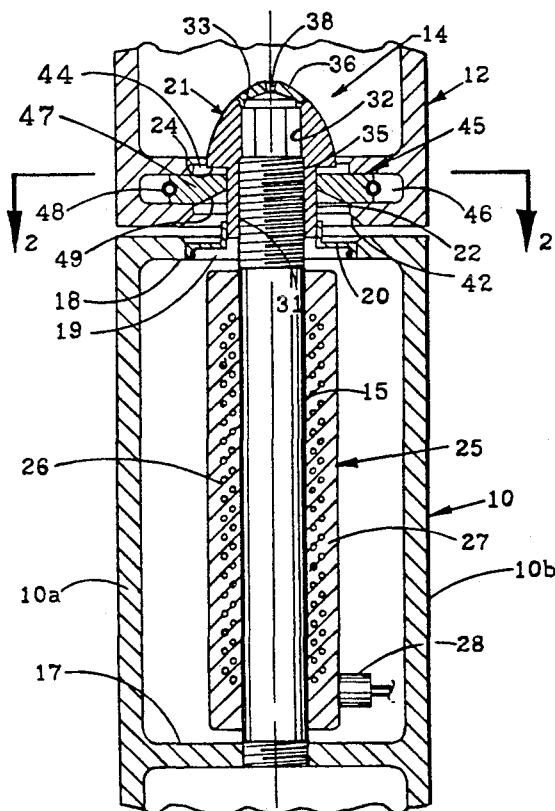

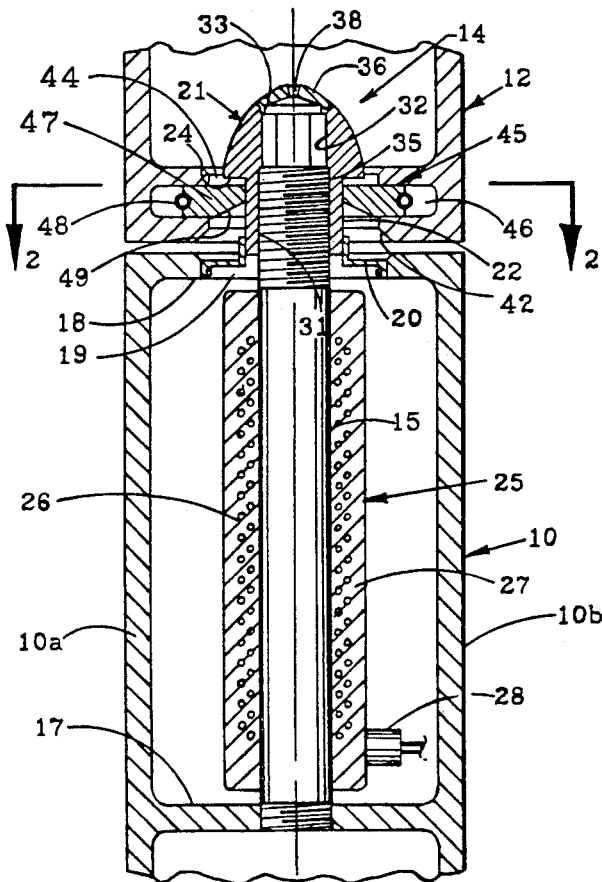

FIG. 1

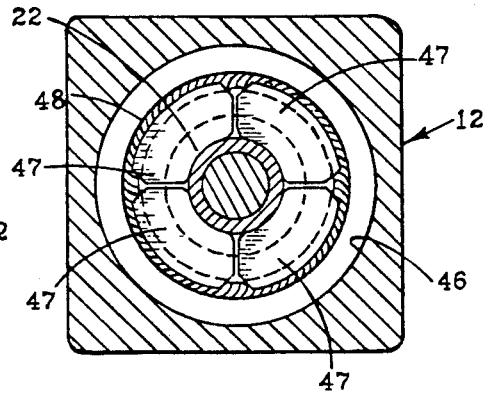

FIG. 2

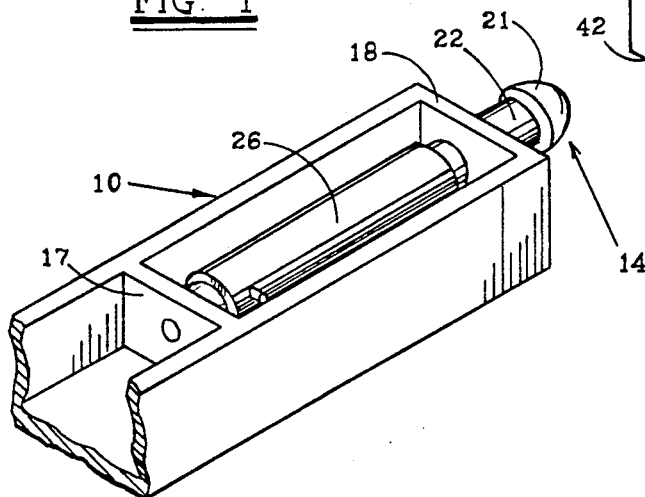

FIG. 3

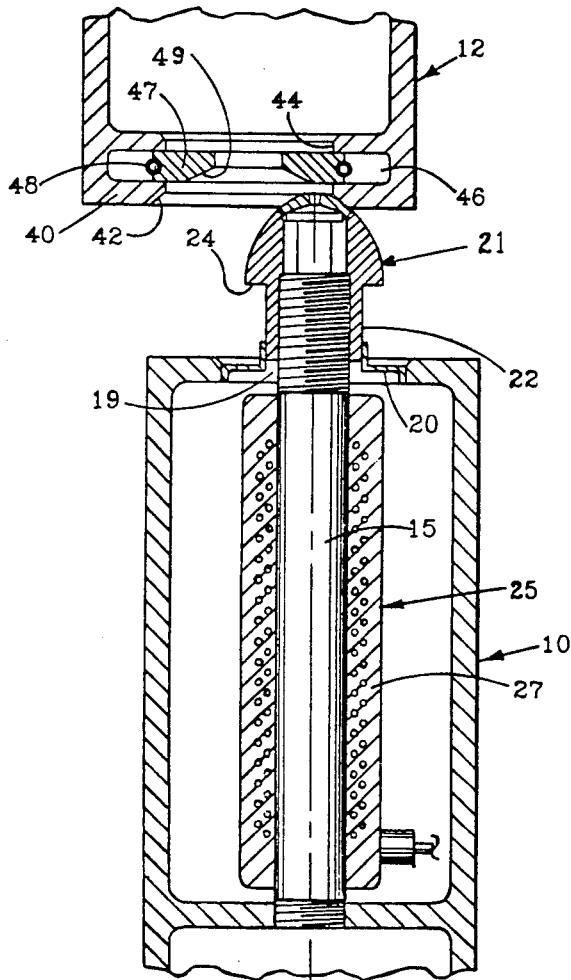

FIG 4

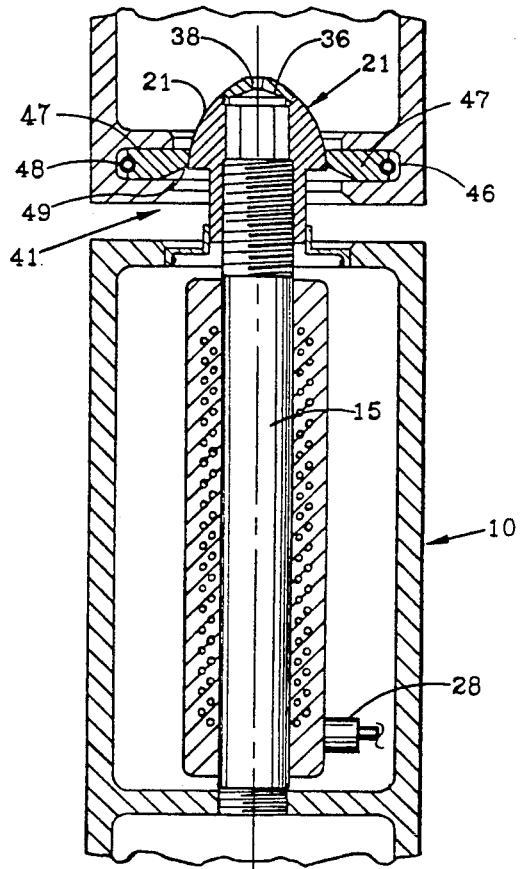

FIG 5

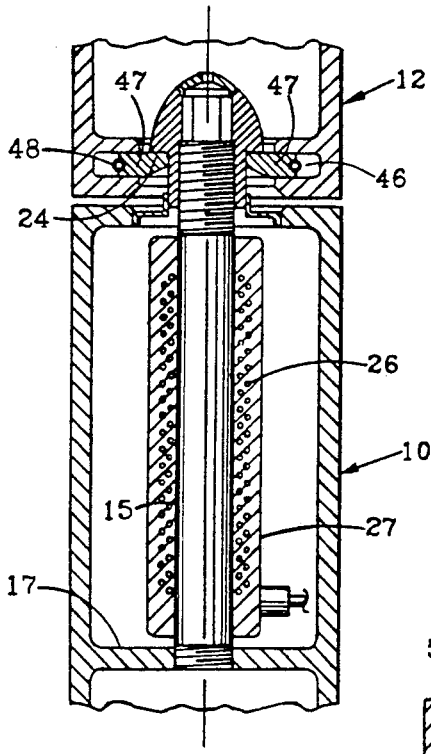

FIG. 6

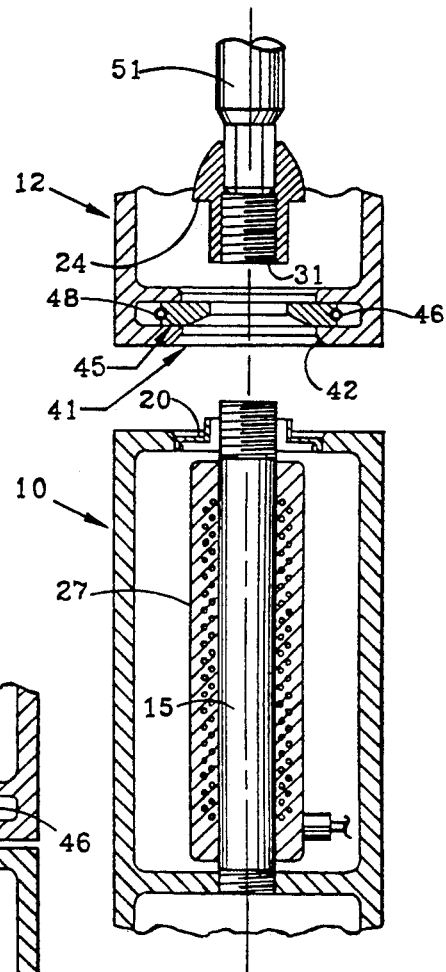

FIG. 7

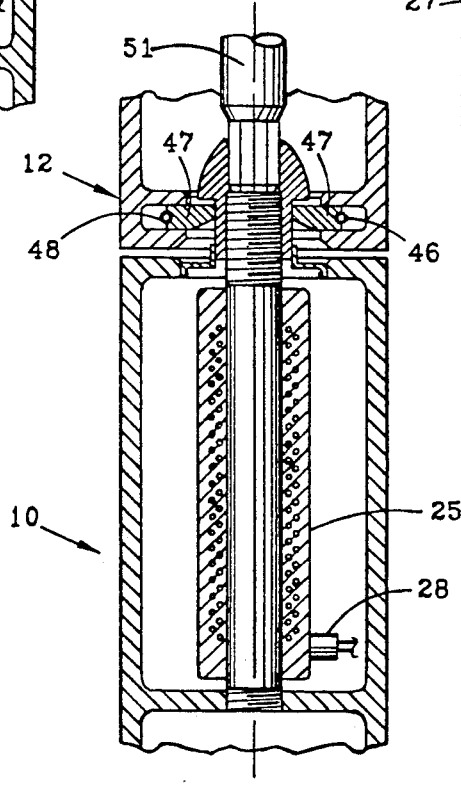

FIG. 8

METHOD AND APPARATUS FOR PRELOADING A JOINT BY REMOTELY OPERABLE MEANS

ORIGIN OF THE INVENTION

This invention described herein was made by an employee of the United States of America for governmental purposes without the payment of any royalties thereon or therefor.

FIELD OF THE INVENTION

This invention relates to the joining of structural elements and more particularly to a method and apparatus for joining structural elements and pre-loading the structural joint by a remotely operable mechanism comprising a memory alloy joining element.

BACKGROUND ART

With many architectural construction techniques, the joining of structural elements for various reasons, as where manual access is impossible or undesirable, can be accomplished by a remotely operable mechanism. In some circumstances, it is also a requirement that the structural tie between the joined elements be preloaded to a value exceeding the worst-case loading to which it may be subjected. Such a method for the joining of structural elements and pre-loading the structural joint by a remotely operable mechanism is an anticipated requirement in construction of a space station in the zero gravity environment where it is foreseen that many of the structural segments must be structurally attached to each other after they are brought into close proximity by the manipulation of the arm of a remote manipulator system and an associated capture latch system. A conventional method of making such an attachment is by a motor-driven bolt system which drives a threaded bolt across from the structural element on the active side of the joint into a floating nut on the passive side of the joint. While this technique provides a convenient method for detachment and reattachment of structural elements, the motor and gearbox at each joint can be a heavy weight penalty, particularly for a one-time connection. Memory alloys have been used in structural joints such as shown in U.S. Pat. No. 4,753,465 wherein a locking mechanism comprising a memory alloy connecting element is releasable by remotely operable means which controls the memory alloy element and in U.S. Pat. No. 4,297,779 wherein a memory alloy connecting element is joined in a dovetail receptacle element. However, neither of these patents relates to the joining of structural elements and imposing a predetermined tensile preload across the structural joint by a remotely operable means.

SUMMARY OF THE INVENTION

The invention is a method and apparatus for the joining of structural elements, designated an active structural element and a passive structural element respectively, and preloading the structural joint by a remotely operable mechanism which comprises a memory alloy joining element. The method and apparatus include the mounting on the active structural element of an elongated shaft of heat contractible material which is capable of changing from an expanded length to a smaller contracted length upon application of heat at a transition temperature sufficient to cause transformation of the shaft to its contracted length. The shaft is provided on one end with a probe head having an external latch-

ing shoulder. The second structural element, designated the passive structure, is provided with a receptacle member adapted to receive the probe head on the heat contractible shaft when the probe head is placed therein. A spring-loaded latching mechanism mounted in the receptacle member is provided with a plurality of latching elements which are adapted to latchingly engage the latching shoulder on the probe head of the heat contractible shaft when the probe head is inserted there-through and thereby loosely join the active and passive structural elements in a state of "soft-capture". A controllable heating means is mounted on the heat contractible shaft and is operable by remote control means to heat the shaft to a transformation temperature which causes the shaft to transform from its expanded length to its smaller contracted length and the latching shoulder of the probe head to lockingly engage with load surfaces on the latching elements and thereby impose on the structural joint, a tensile pre-load of predetermined magnitude.

By provision of a removable cap on the probe head and insertion of a tool in the socket uncovered by removing the cap, means are provided for manually detaching the probe head from the shaft to effect release of the joined structures or to manually impose a tensile pre-load on the structural joint.

BRIEF DESCRIPTION OF THE DRAWINGS

FIG. 1 is a sectional view through a pair of structural elements, representing an active structure and a passive structure, after the pair have been moved together in a loose coupling "soft-capture" relationship;

FIG. 2 is a sectional view as taken along the section line 2—2 of FIG. 1 showing details of the spring-loaded latching system which is mounted in the structural element which represents the passive structure;

FIG. 3 is a view in perspective of the two structural elements to be joined showing the two structures as they are brought into close proximity to one another;

FIG. 4 is a sectional view of the two structural elements as they are first brought together and showing a probe mounted in the active structural element and making initial contact with a conical receptacle surface provided in the passive structural element;

FIG. 5 is a view similar to FIG. 4 but showing the probe positioned deeper into the conical receptacle and engaging and spreading latching ring segments of the spring-loaded latching system;

FIG. 6 is a sectional view showing the structural elements of FIG. 1 after having been joined together and a tensile preloading applied to the joint by a remotely operable mechanism of the invention;

FIG. 7 is a sectional view showing the structural elements in separated condition after having been released from their joined condition by means of a power tool inserted into the probe head, and

FIG. 8 is a sectional view of the structural elements after having been joined together and a power tool inserted into an opening in the probe and applying a tensile pre-load to the structural joint.

DETAILED DESCRIPTION OF THE INVENTION

Referring more particularly to the drawings, there is shown in FIG. 1, a structural element 10, which is loosely coupled to a passive structural element 12 after they have been pulled together by an appropriate cap-

shown in FIG. 1, the ring segments 47 are sprung back inwardly by the spring 48 until they contact the cylindrical neck 22 of the probe head. In this condition, the structural element 10 is loosely coupled to the structural element 12 and is in a state of "soft-capture".

However, for connecting the structures 10 and 12 together on a permanent basis and to maintain a maximum stiffness of the structural tie therebetween, the joint must be preloaded to a value which exceeds the anticipated worst-case loading. By an application of heat to the probe shaft 15 which raises its temperature to the known transition temperature range, the shaft 15 is caused to shrink to its predetermined given length and thereby impose a tensile preload on the structural joint by the clamping action of the shoulder 24 of the probe head 21 against the upper surfaces of the latch ring segments 47 as shown in FIG. 6.

For applying heat to the probe shaft 15, it is fitted with a heating collar 25 which consists of a wire coil 26 encapsulated in a ceramic electrically insulating material 27. The heating collar is sleeved tightly about the

wall 17 where the shaft is fastened permanently. Any environmental heating of the joint will cause an increase in strength if the transformation temperature is exceeded because the austenite yield strength is much higher than the martensite.

It is to be noted that a precaution remains to be taken after the probe shaft is installed in the structure. It is very important that the memory alloy shaft be kept below its transformation temperature to prevent an accidental activation. Since it is not always practical to keep the shaft refrigerated during transportation, as in the payload bay of the Space Shuttle, the memory alloy should be of such composition that its transformation temperature is above that of all temperatures to be experienced prior to planned activation.

The four latching ring segments 47 are designed to be installed in the structure without the need of a removable flange. Since each segment is small enough to fit through the hole 41, the last segment may be installed by spreading the first three segments apart deeper into the recess 46. A small lateral misalignment between the

It is also to be appreciated that the foregoing description of the invention has been presented for purposes of illustration and explanation and is not intended to limit the invention to the precise form disclosed. For example, the memory alloy joint described herein may be used to join structural members where the structural members are not necessarily channelled members so long as there is enough volume or space, primarily as relating to the length dimension, to allow the system to function. Also, if precise alignment between structures is a requirement of the joint, the collar 20 may be designed with a conical shape to mate with the conical entry hole in the passive structure 12. It is to be appreciated therefore, that changes may be made by those skilled in the art without departing from the spirit of the invention.

I claim:

1. Apparatus for joining a pair of structural elements and imposing a tensile preload on the structural joint, said apparatus comprising:
 - a probe including an elongated shaft of heat contractible material capable of changing from an expanded length to a contracted length upon an application of heat in a specific transition temperature range, said shaft being provided at one end with a probe head having an external latching shoulder formed thereabout;
 - means for mounting said shaft on a first of said structural elements with the probe head thereof projecting therefrom, the second of said structural elements being provided with a receptacle opening adapted to receive the probe head of said shaft when the first structural element is moved in proximity to the second structural element with said shaft in approximate alignment with the receptacle opening;
 - a latching system mounted on said second structural element adjacent to the receptacle opening for latchingly engaging said probe head when the probe is inserted a predetermined minimal distance into said receptacle opening and thereby forms a loose soft-capture joint between said first and second structural elements; and
 - means for heating said elongated shaft to said transition temperature range to cause said shaft to transform from said expanded length to said contracted length and said latching shoulder to engage with said latching mechanism and impose a tensile preload across said joint.
2. An apparatus for joining a pair of structural elements as set forth in claim 1, wherein said elongated shaft is a memory alloy of nickel and titanium.
3. An apparatus as set forth in claim 1 wherein said elongated shaft is a memory alloy which in its expanded length is in the martensite phase of crystallization and which recovers to the austenite phase as the shaft transforms to its contracted length upon application of heat

each of said segments being movable in a radial direction with respect to said circle, and a circular tension spring positioned circumferentially about the circular array of ring segments in engagement with said ring segments and biasing the ring segments to an innermost position in circular array defining an opening adapted to receive the probe head of said shaft whereby said latch ring segments are moveable radially outward by initial penetration of said probe head and are moveable radially inward to said innermost position by said spring upon further penetration of said probe head by said predetermined minimal distance to thereby effect a soft-capture joint between said first and several structural elements.

6. An apparatus as set forth in claim 5 wherein said second structural element is provided with an outwardly diverging frusto-conical surface for defining said receptacle opening and facilitating the entry of the probe shaft therein.
7. A process for joining a pair of structural elements and for imposing a tensile preload on the resulting structural joint, said process comprising:
 - stretching an elongated shaft of heat contractible metal alloy from a predetermined length to an expanded length,
 - fitting one end of said shaft with a probe head having an external latching shoulder formed thereabout,
 - mounting said shaft on a first of said structural elements with the probe head projecting therefrom,
 - providing the second of said structural elements with a receptacle opening adapted to receive the probe head of said shaft therein and a latching system mounted adjacent to the receptacle opening and comprising a plurality of latching elements with load bearing surfaces extending radially with respect to the axis of said opening, said latching system being adapted to latchingly engage the probe head of said shaft when said probe head is inserted a predetermined minimal distance into the receptacle opening to thereby form a loose soft-capture joint between said first and second structural element,
 - moving said first structural element to where said probe head engages the second structural elements substantial alignment with said receptacle opening and to where said probe head is inserted said predetermined minimal distance into said receptacle opening, whereby said latching system latchingly engages the probe head to form a loose soft-capture joint between said first and second structural elements, and
 - heating said elongate shaft to a transition temperature range which causes said shaft to contract from its expanded length to said predetermined length and the latching shoulder of the probe head to engage with said load bearing surfaces of the latching elements,