

NTF MODELING PROGRAM

L. WAYNE MCKINNEY

ASSISTANT CHIEF, TRANSONIC AERODYNAMICS DIVISION

NASA LANGLEY RESEARCH CENTER

NTF
N92-70486

53-04
0.71

NTF PERFORMANCE ESTIMATION
AND MODELING

PRESENTED AT LERC WORKSHOP ON
WIND TUNNEL MODELING
MARCH 20 AND 21, 1984

L. W. MCKINNEY

AERODYNAMIC DESIGN CRITERIA

● TEST SECTION SIZE: (2.5 METERS SQUARE)

● FLOW QUALITY IN TEST SECTION

▲ TURBULENCE INTENSITY

$$T_i = \pm .001$$

▲ FLUCTUATING STATIC PRESSURE

$$\Delta C_p = \pm .002$$

▲ FLOW UNIFORMITY

$$\frac{\Delta q}{q} = \pm .001$$

▲ NOISE, SPL

$$= 150\text{db}$$

● MINIMIZE OPERATING COSTS

NATIONAL TRANSONIC FACILITY PLAN OF TUNNEL CIRCUIT

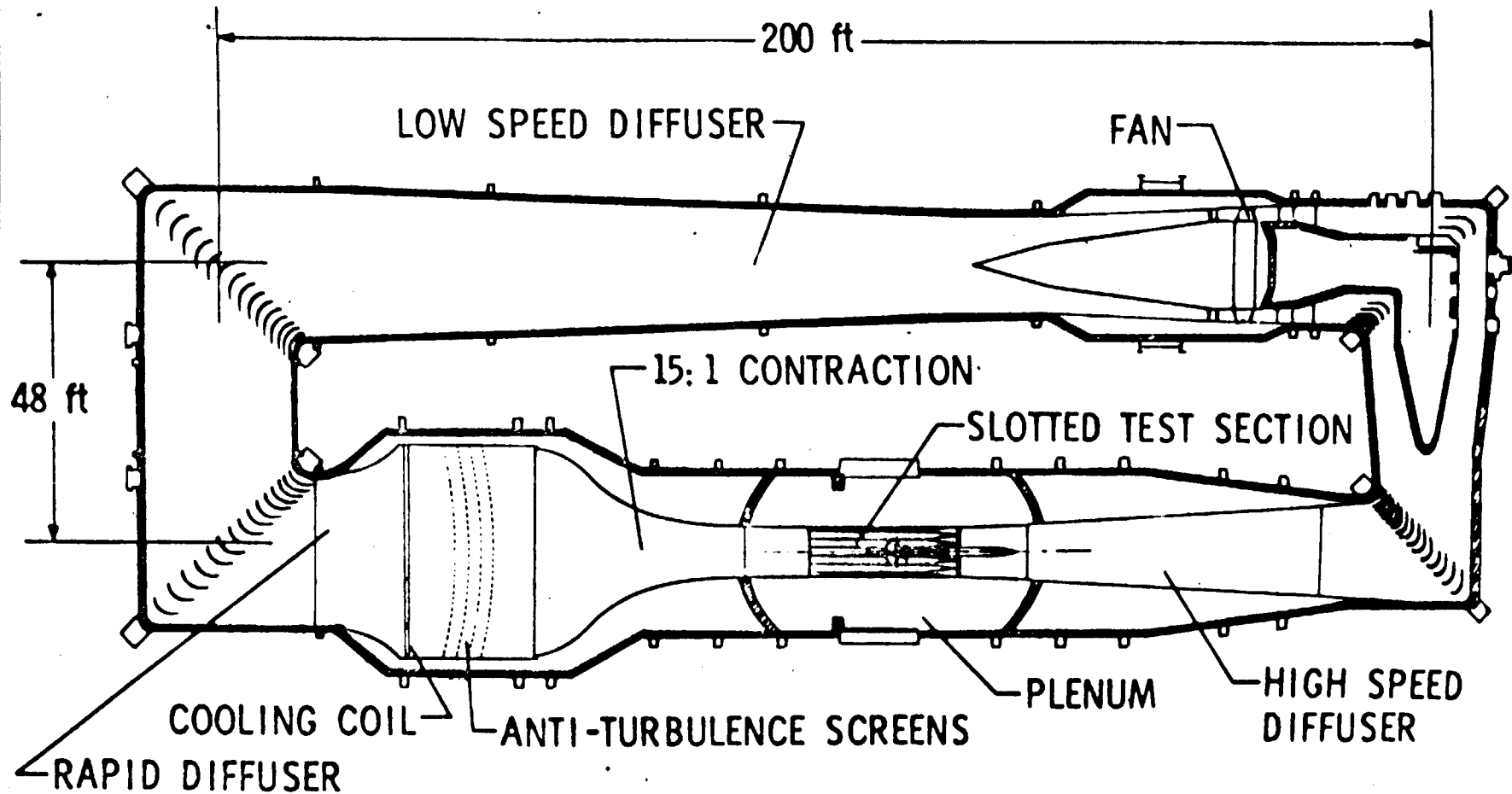

COMPARISON OF THE NTF AND THE 8FT. TRANSONIC PRESSURE TUNNEL

8FT TRANSONIC PRESSURE TUNNEL (SCALED TO MATCH NTF TEST SECTION SIZE)

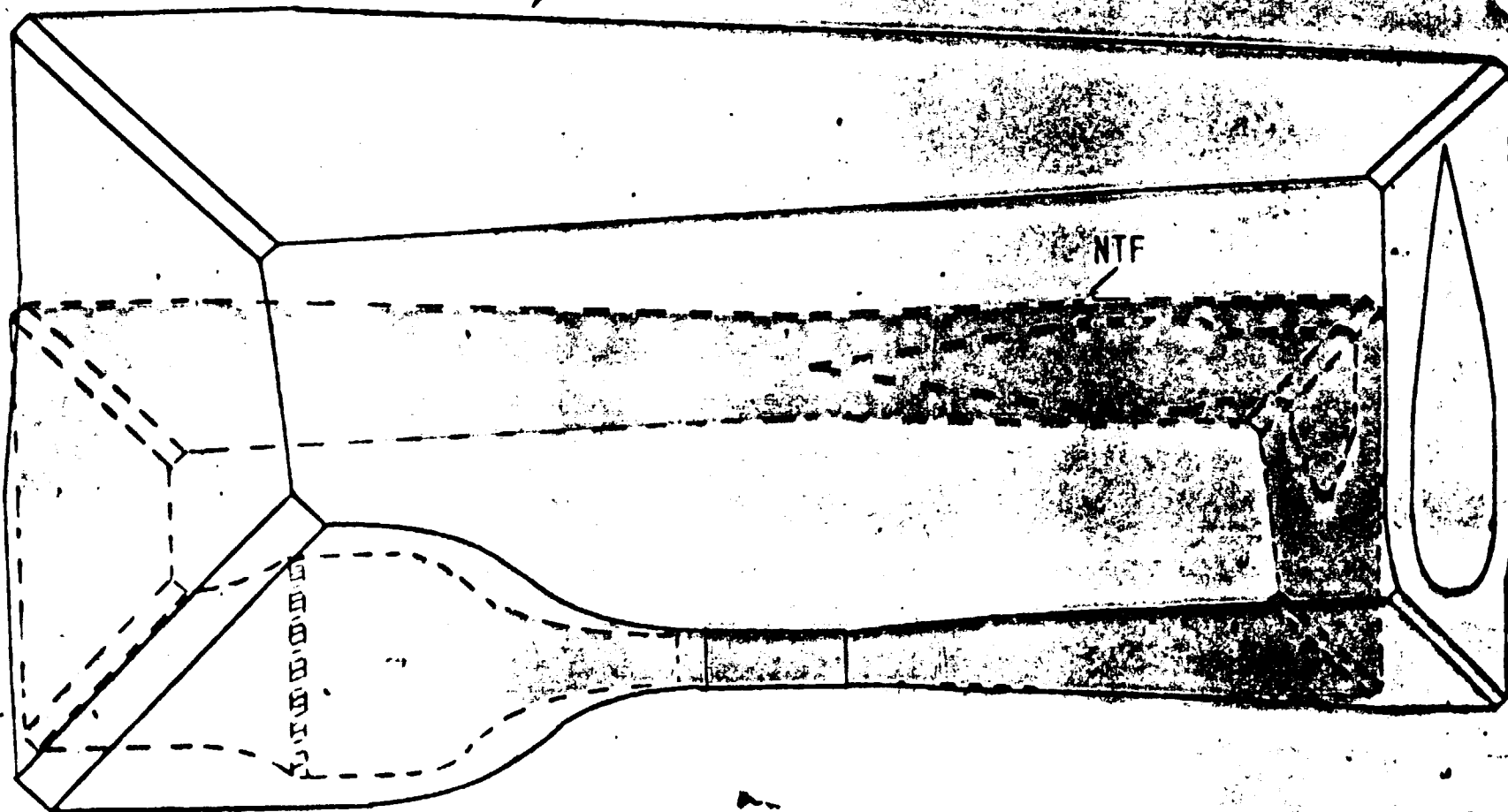

ORIGINAL PAGE IS
OF POOR QUALITY

AERODYNAMIC VALIDATION MODELS

- 1/5.4 SCALE PERFORMANCE MODEL
 - TUNNEL PRESSURE RATIO
 - AERODYNAMIC LOADS
 - EFFECT OF PLENUM BLEED

- 1/12 SCALE COMPONENTS
 - SECOND TURN PERFORMANCE
 - QUICK DIFFUSER PERFORMANCE
 - COOLING COIL TESTS
 - AERODYNAMIC LOADS

- 0.3-METER CRYO TUNNEL
 - REYNOLDS NUMBER EXTRAPOLATIONS
 - COOLING COIL TEST AT FULL SCALE REYNOLDS NUMBER

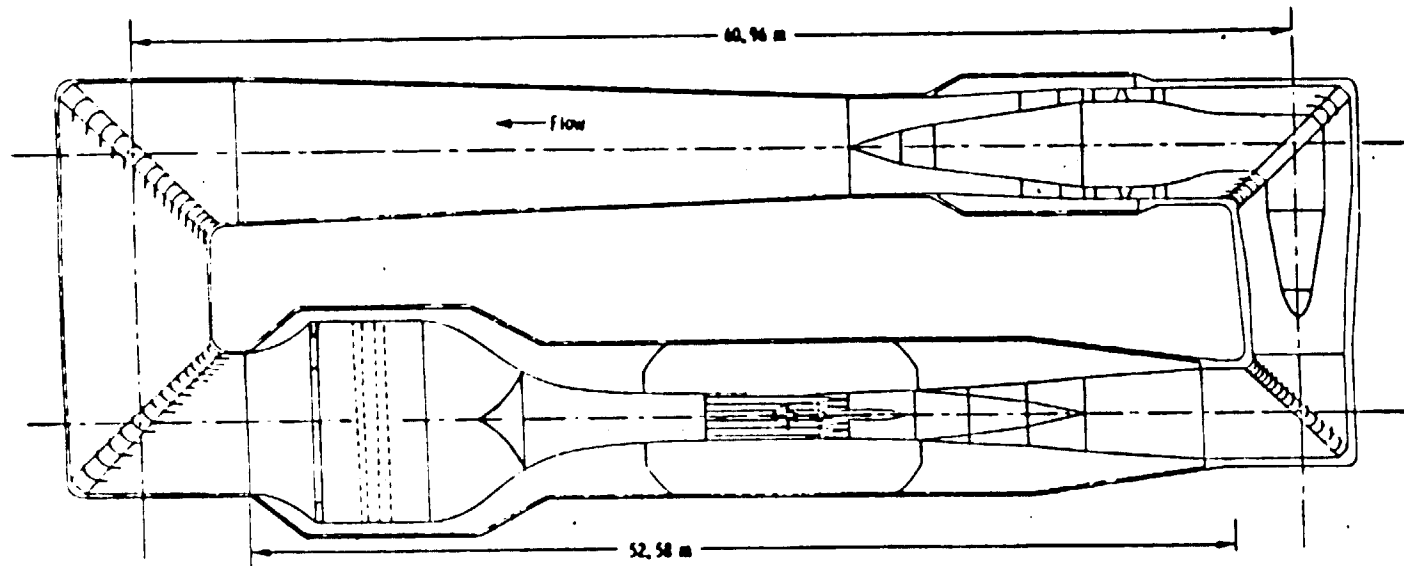

National Transonic Facility

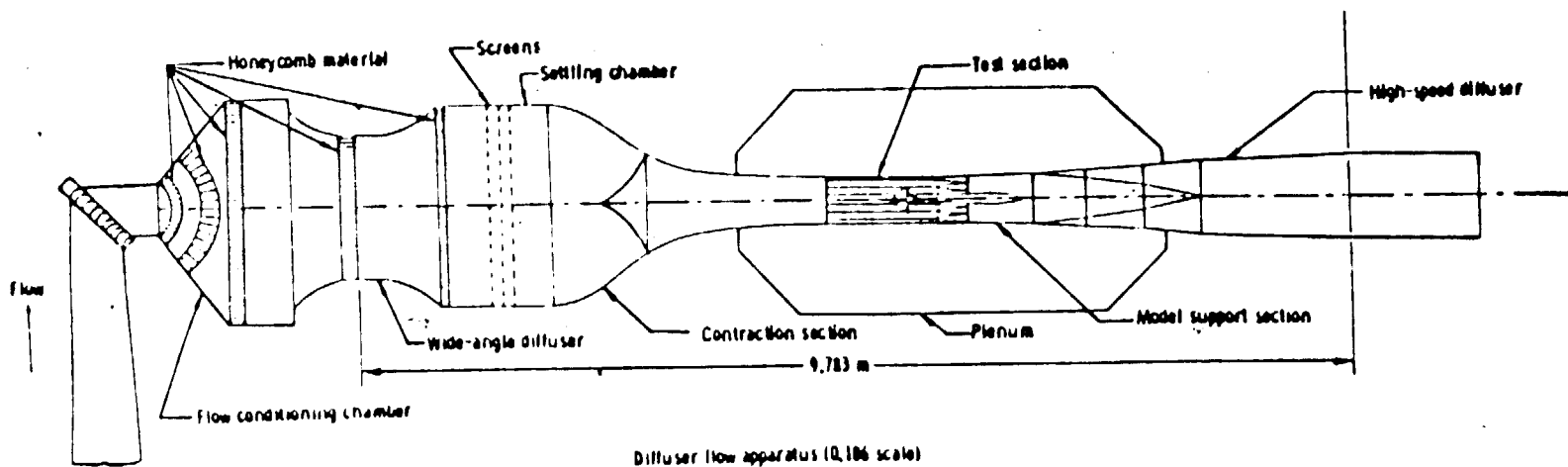

Diffuser flow apparatus (0.186 scale)

Comparison showing extent of representation of NTF by DFA.

ORIGINAL PAGE IS
OF POOR QUALITY

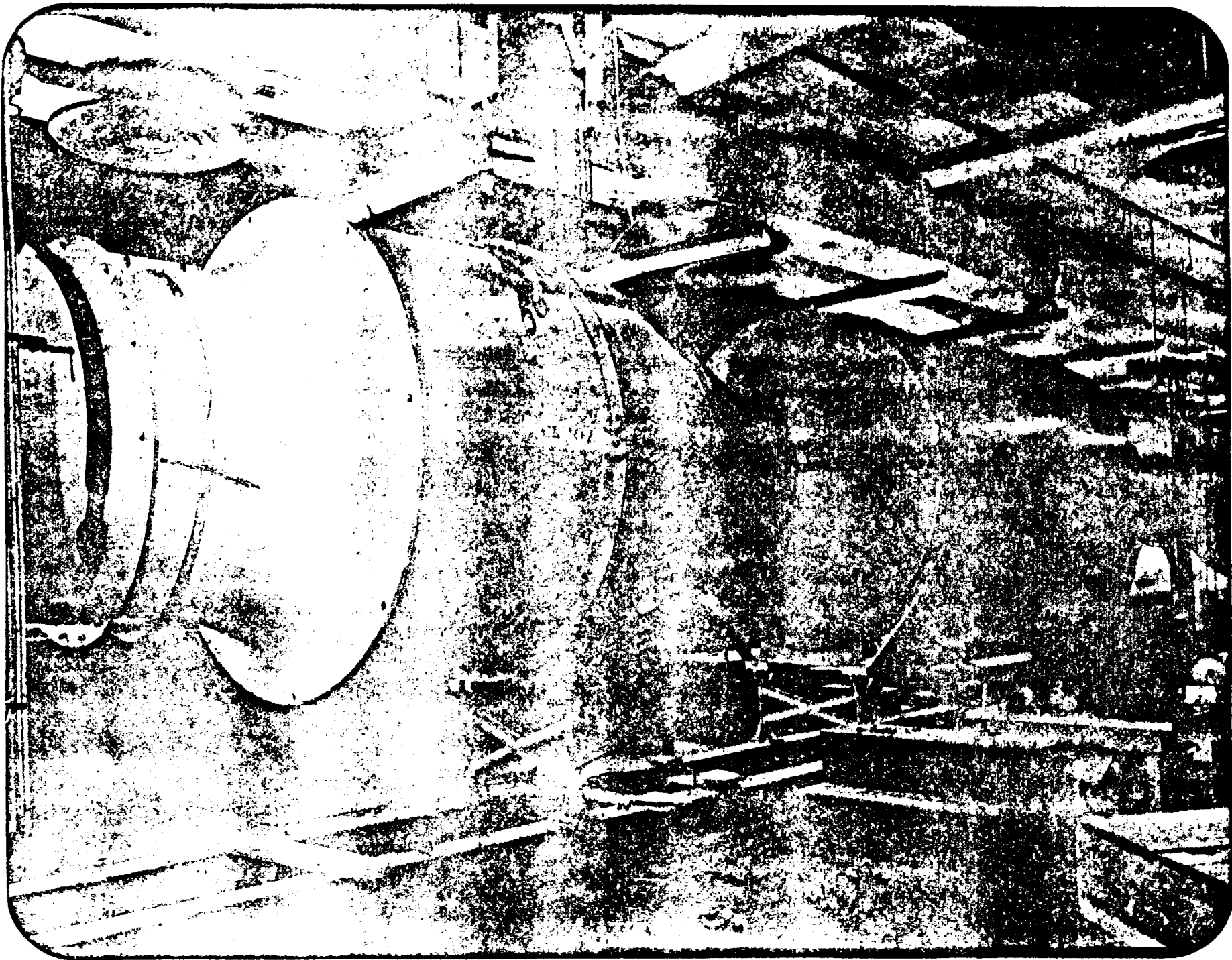

NASA LANGLEY RESEARCH CENTER

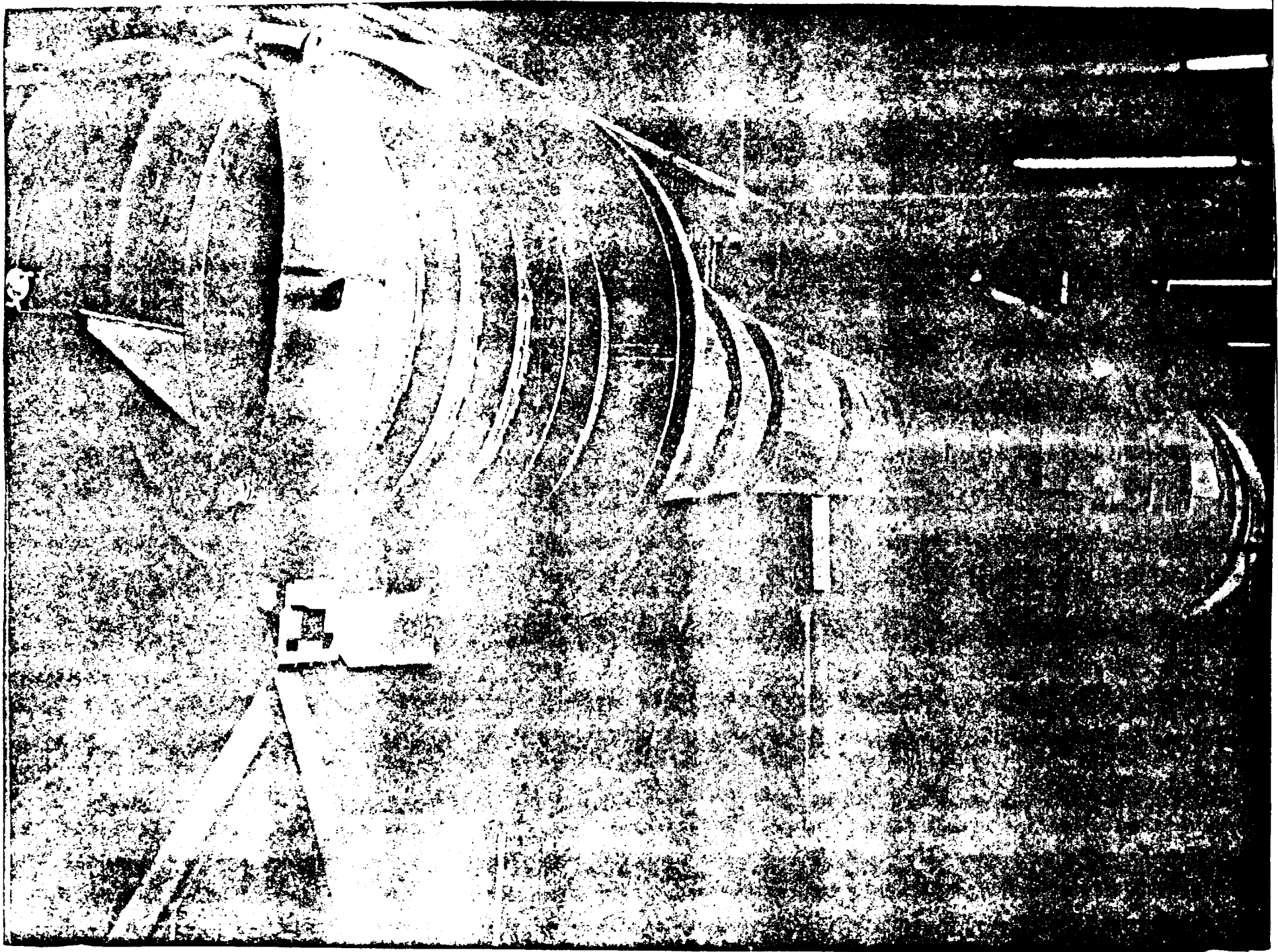

ORIGINAL SOURCE IS
OF POOR QUALITY

1/12 SCALE MODELS OF NTF COMPONENTS

2 ND TURN

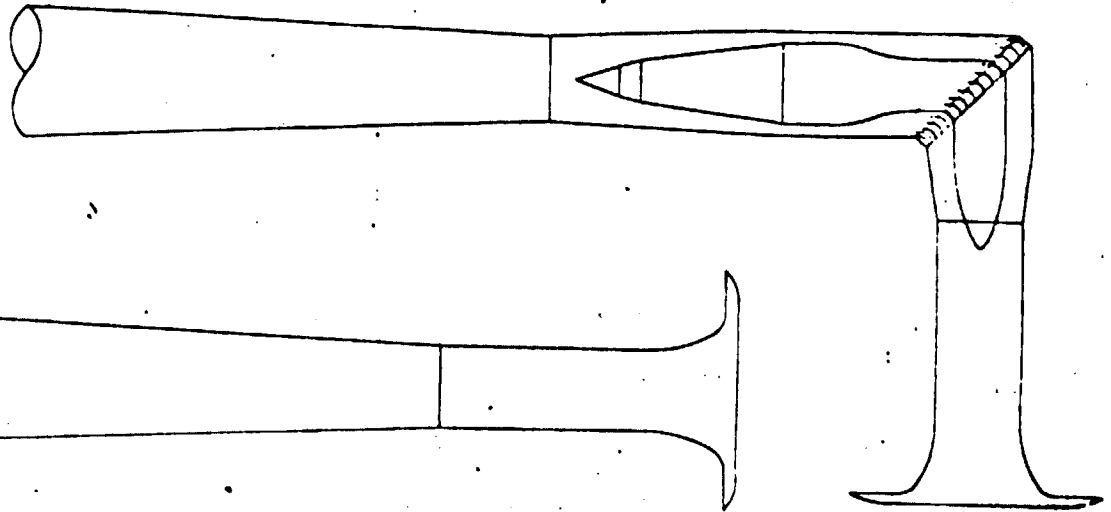

3 RD TURN

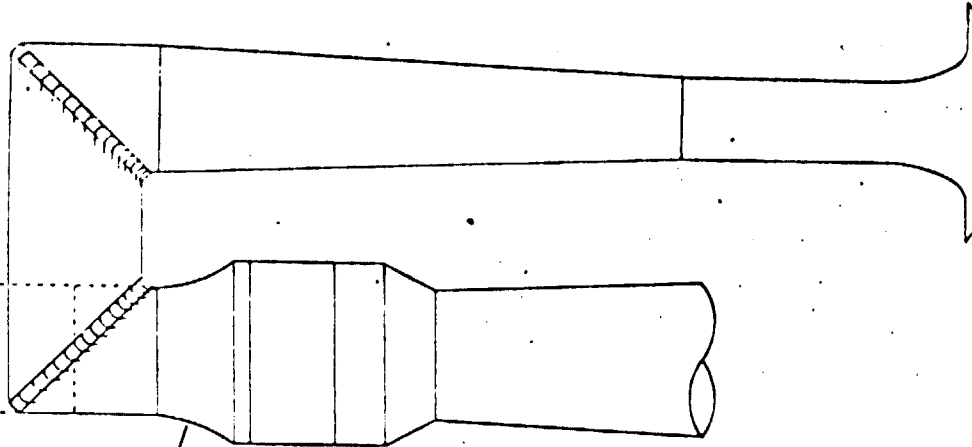

4TH TURN

RAPID DIFFUSER

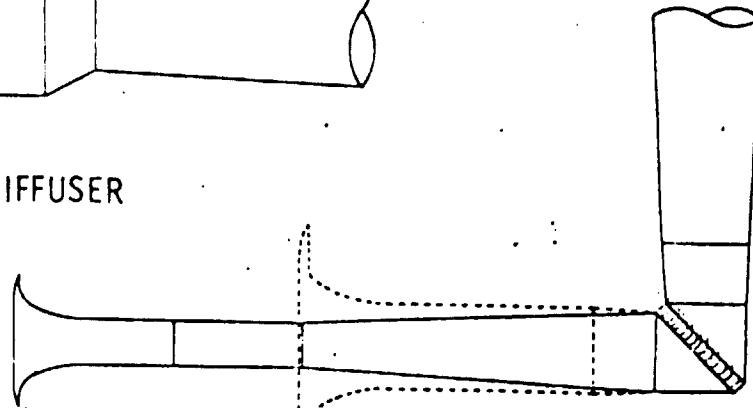
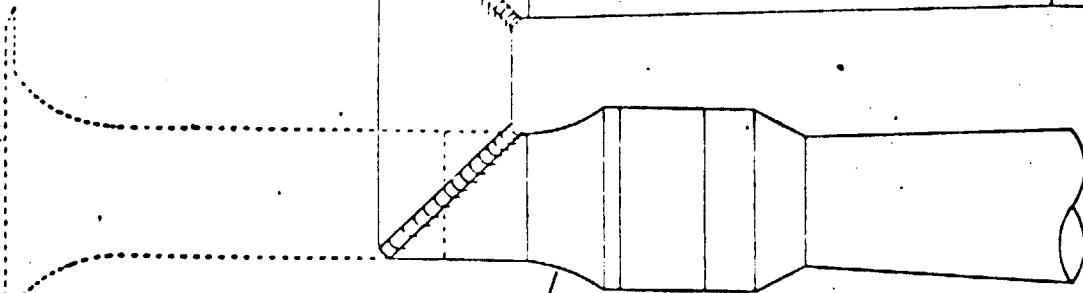

1ST TURN

ORIGINAL PAGE IS
OF POOR QUALITY

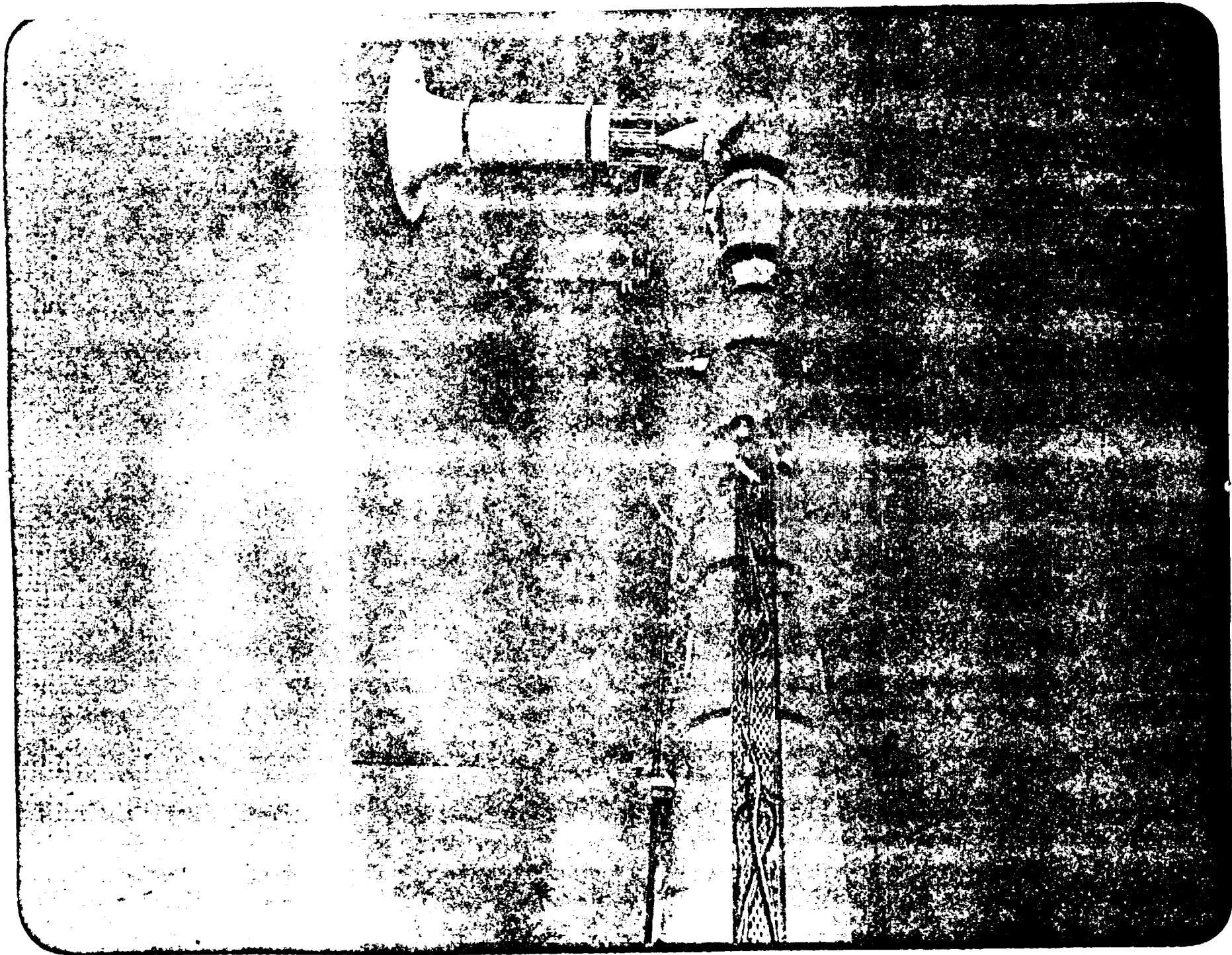

NASA LANGLEY RESEARCH CENTER

LANGLEY 34 cm (13.5") PILOT TRANSONIC CRYOGENIC TUNNEL

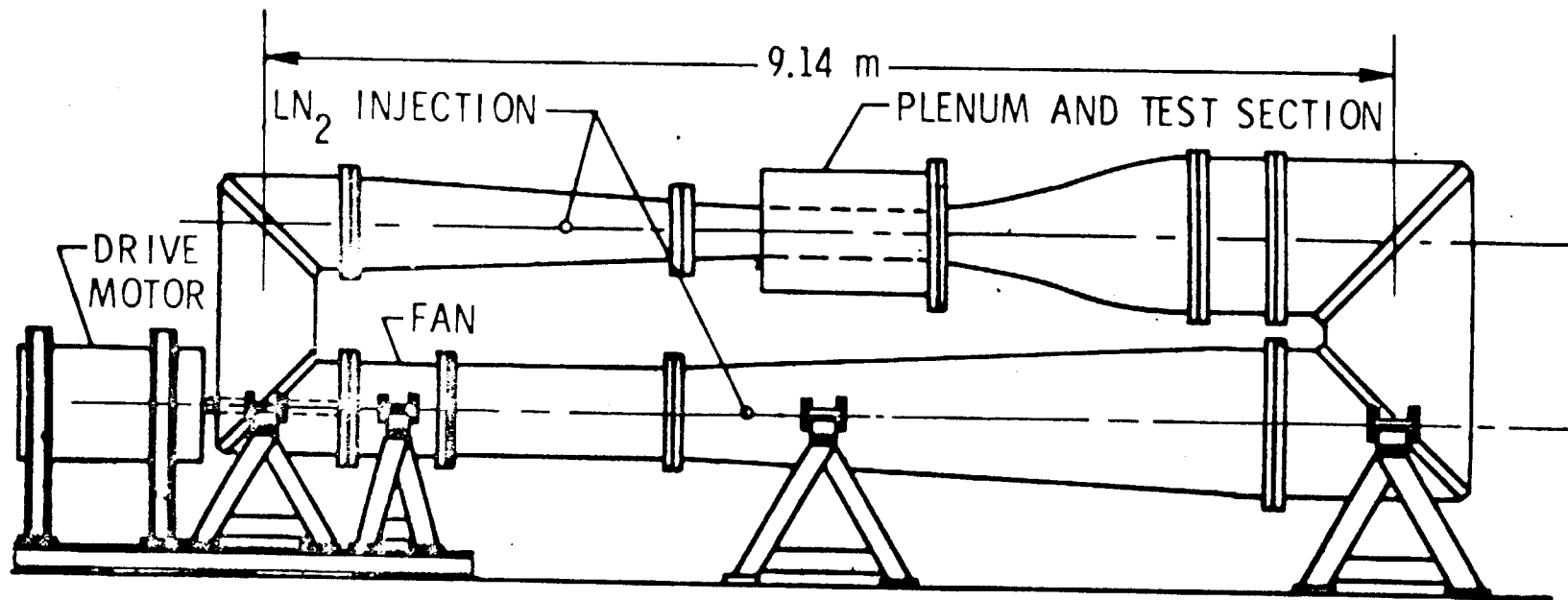

ORIGINAL PAGE IS
OF POOR QUALITY

NASA LANGLEY RESEARCH CENTER

NATIONAL TRANSONIC FACILITY PLAN OF TUNNEL CIRCUIT

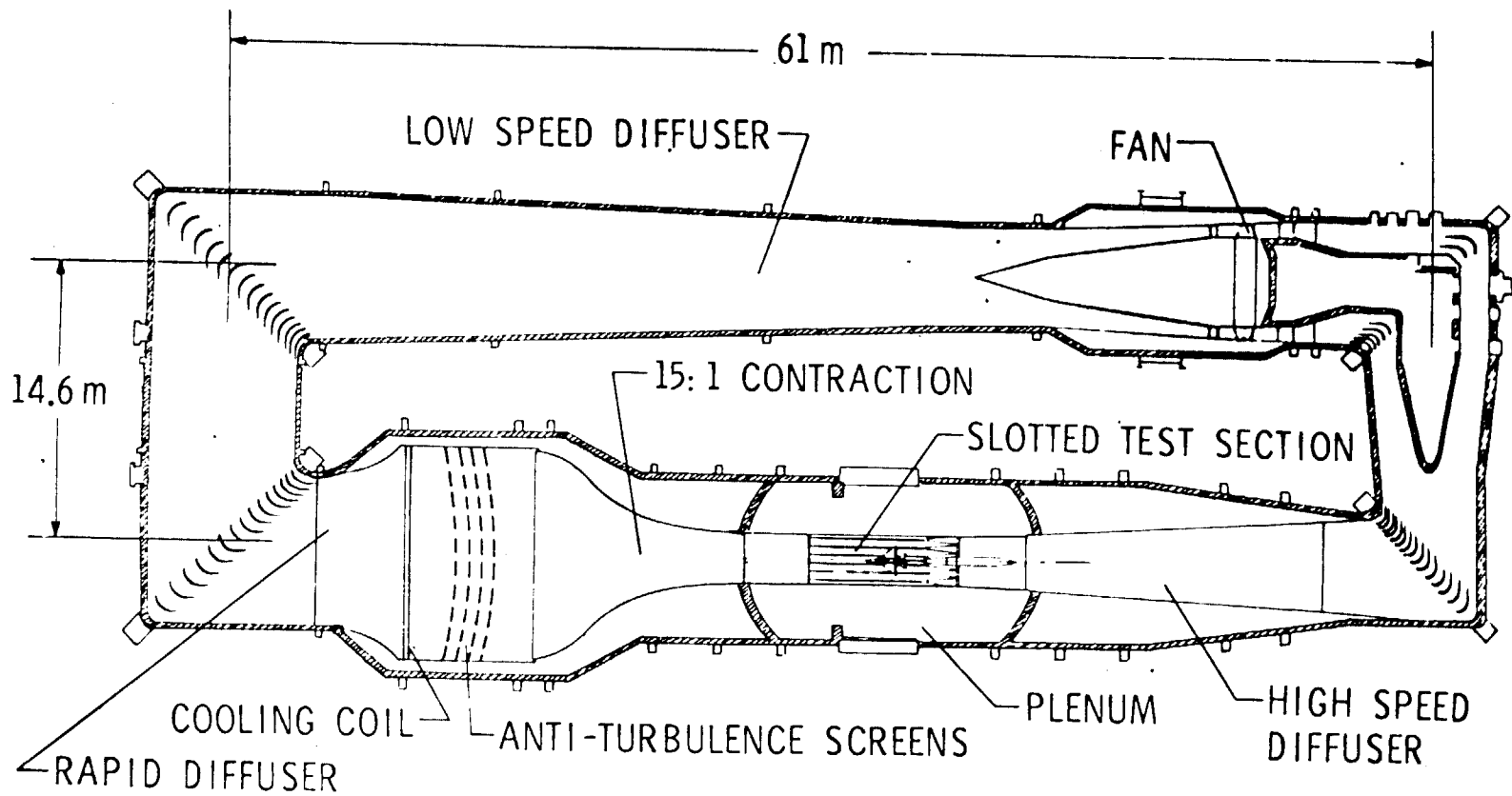

NTF PERFORMANCE MODEL

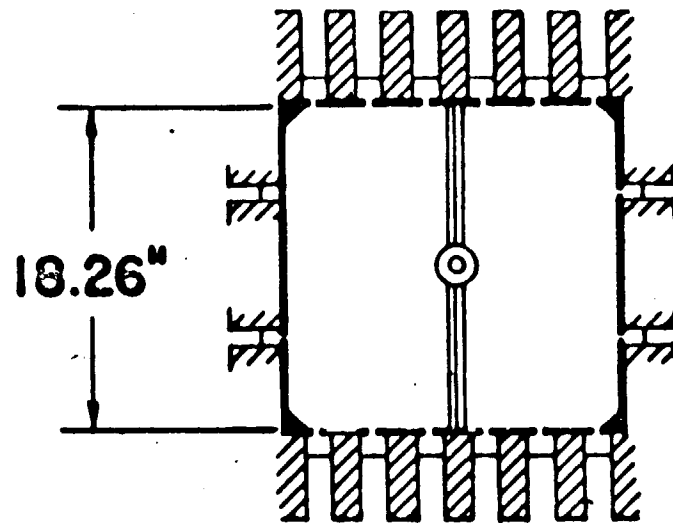
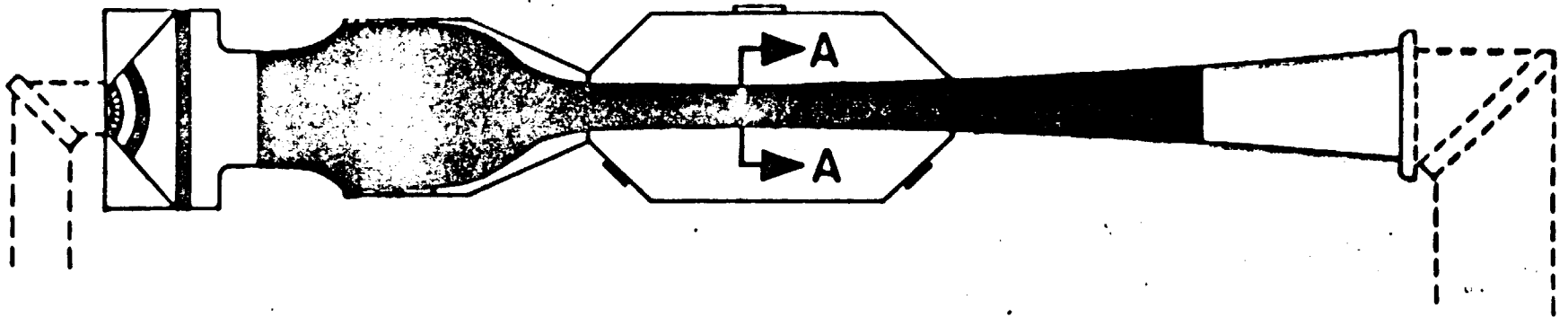

SECTION A-A

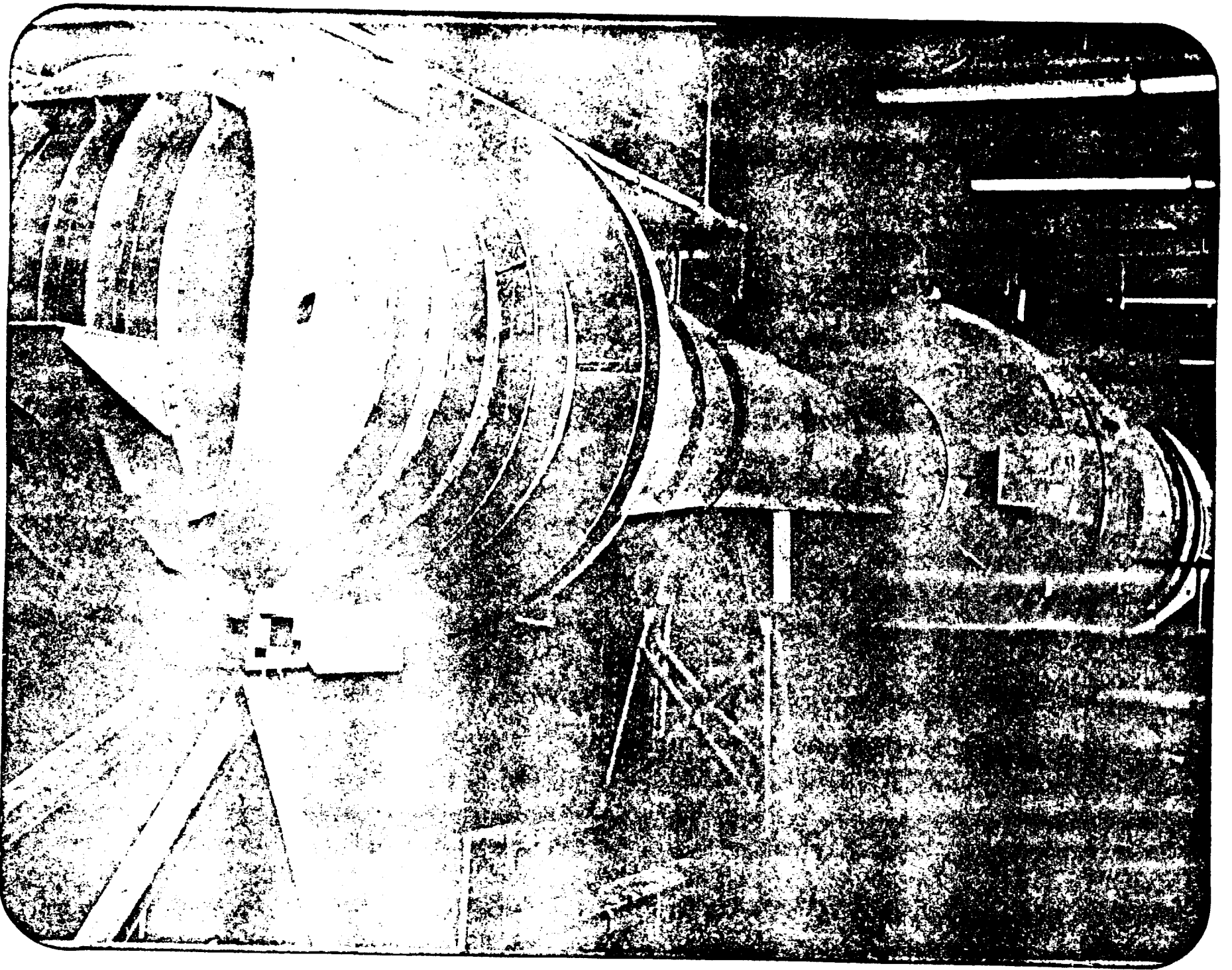

ORIGINAL PAGE IS
OF POOR QUALITY

NTF FAN PRESSURE RATIO
RN = 4 X 10⁶/FT

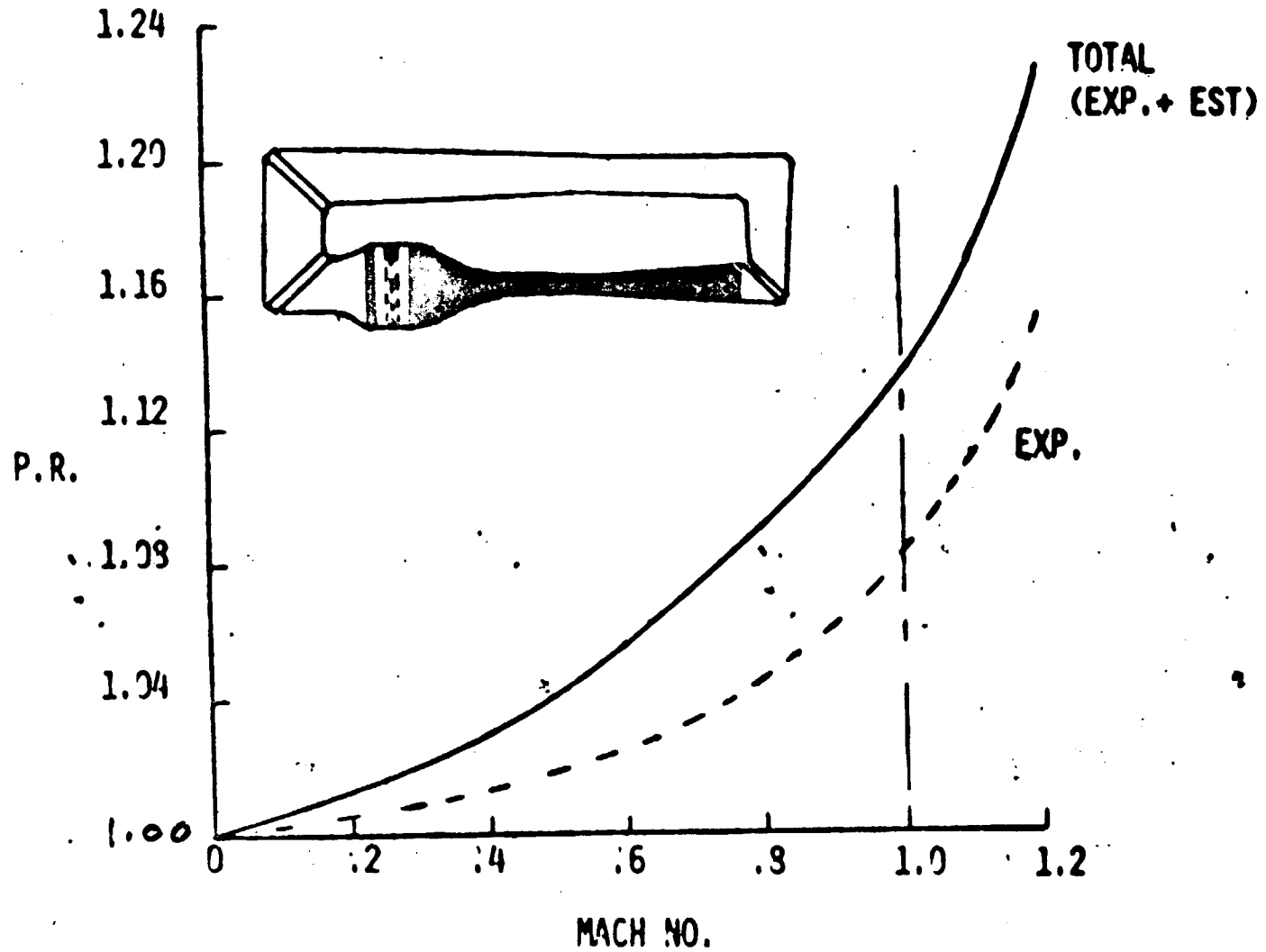

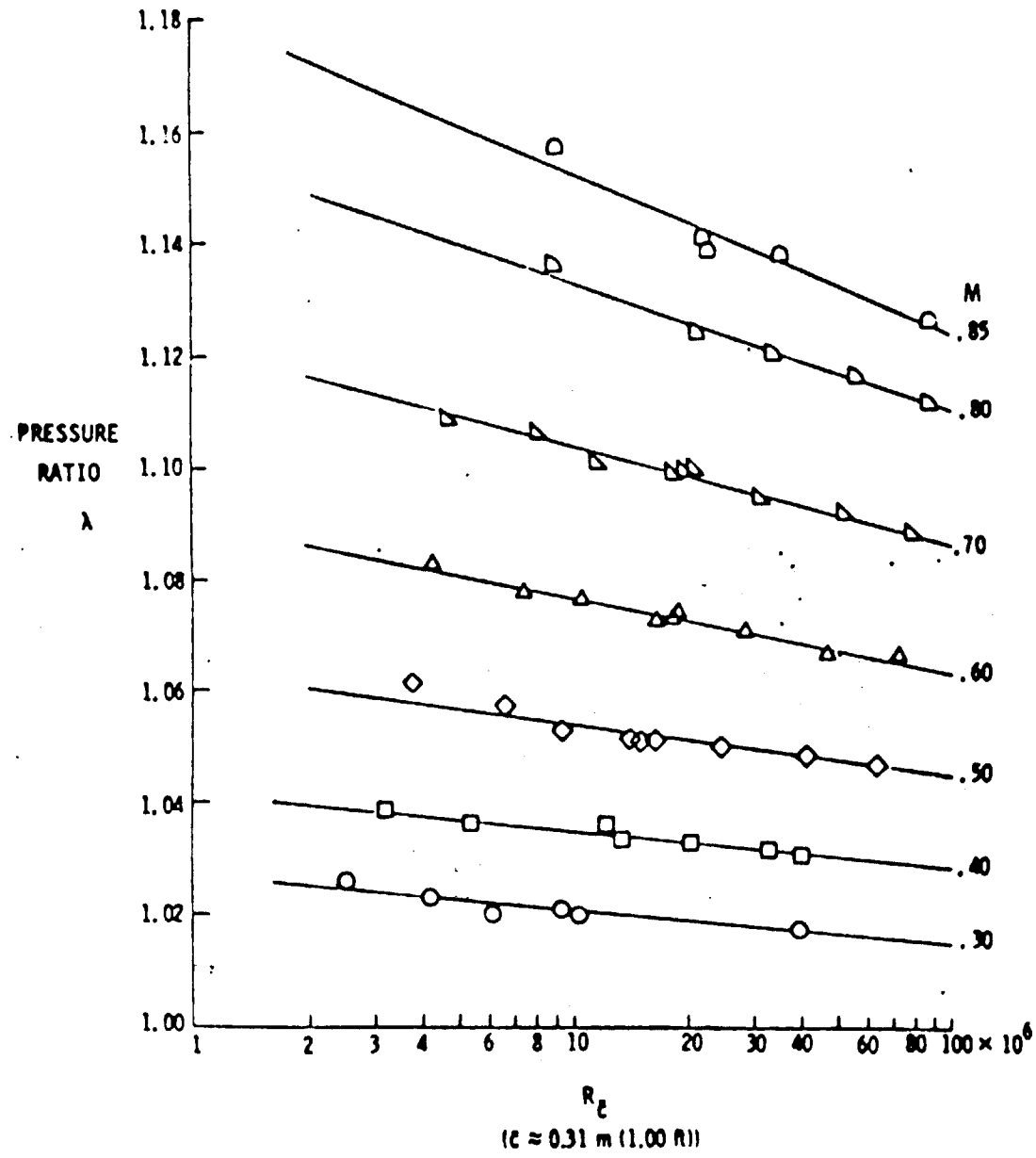

Effect of Reynolds number on tunnel pressure ratio
0.3-Meter Transonic Cryogenic Tunnel.

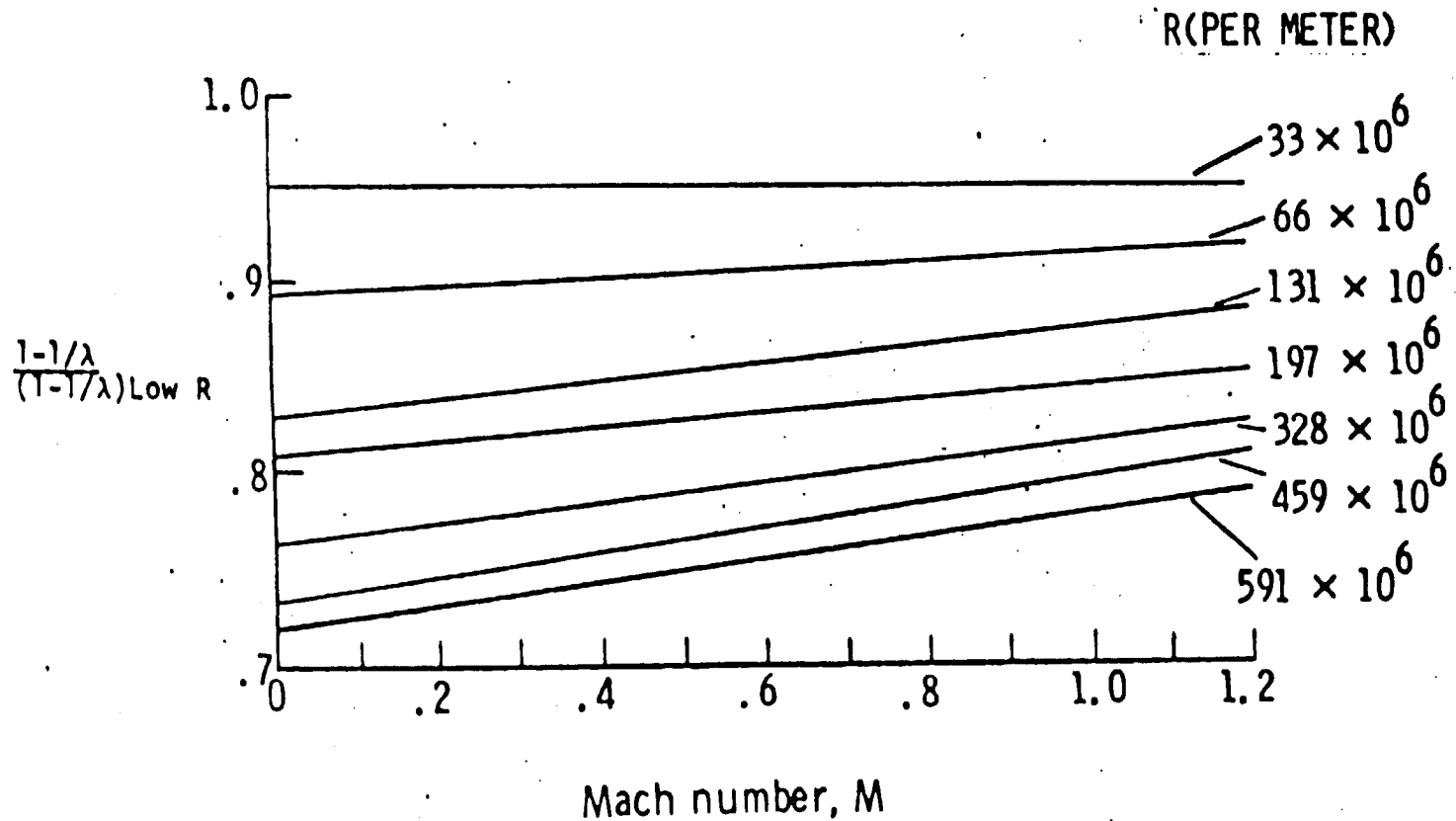

EFFECT OF REYNOLDS NUMBER ON TUNNEL PRESSURE LOSS.

NTF PRESSURE RATIO

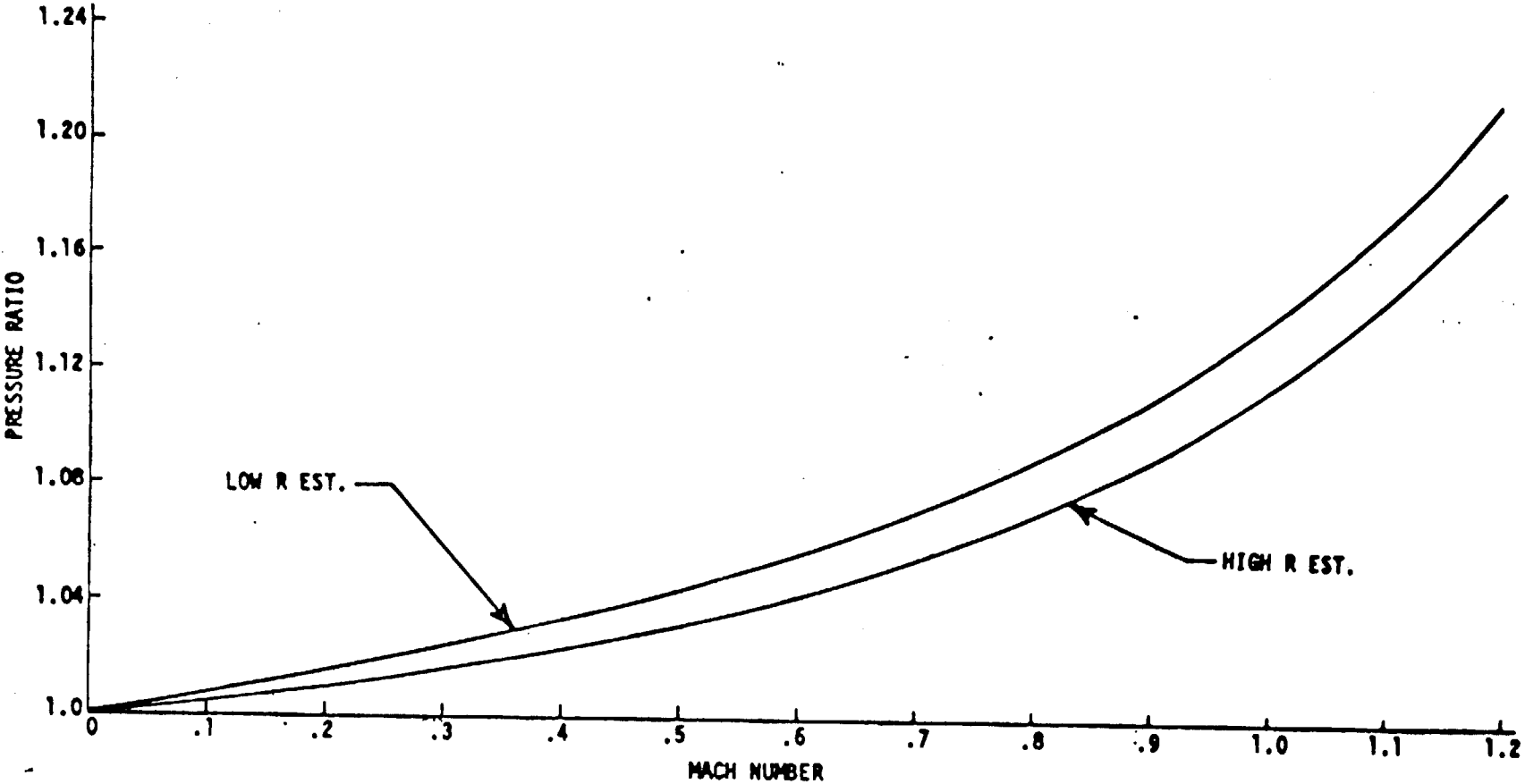

NTF PRESSURE RATIO

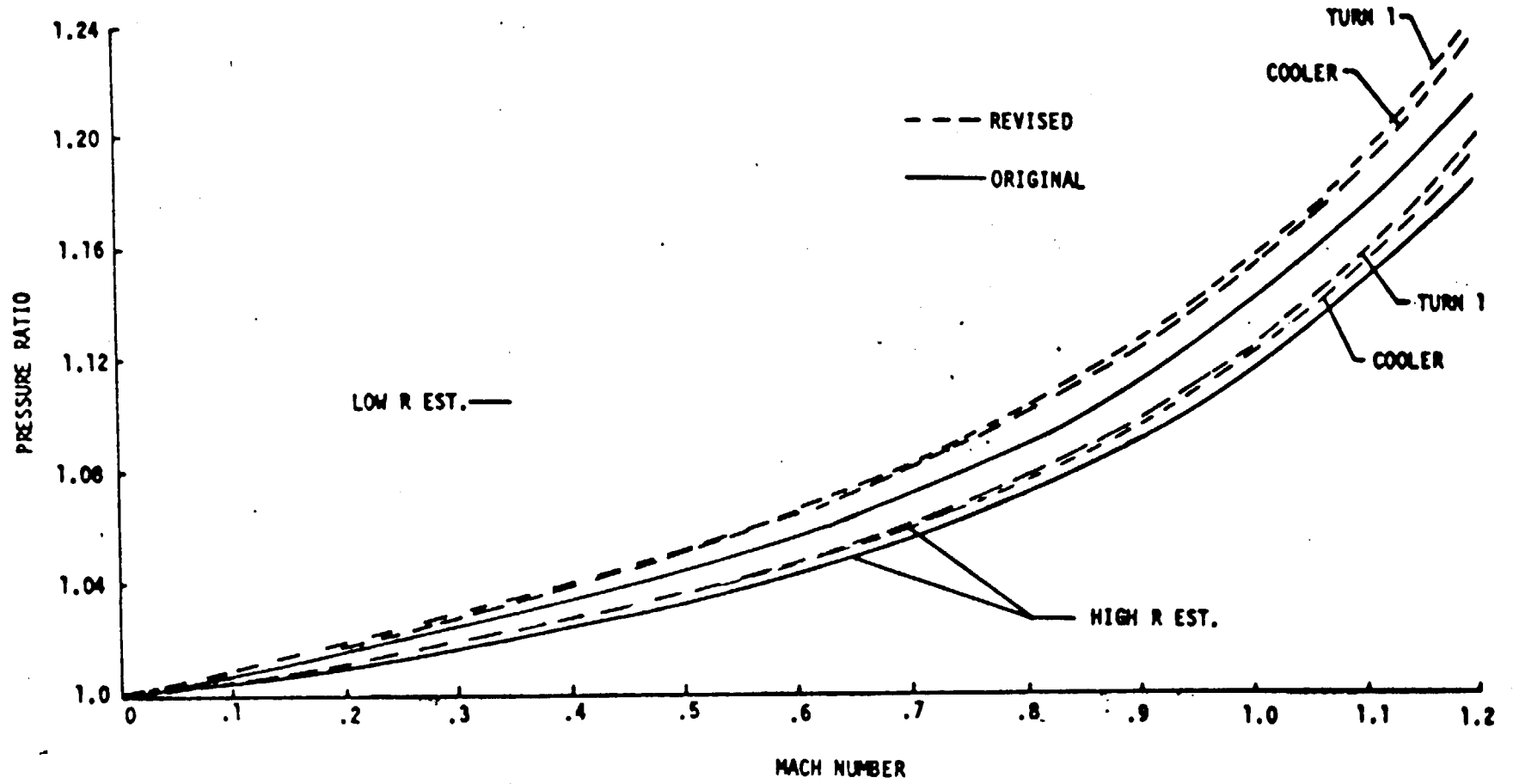

NTF PRESSURE RATIO

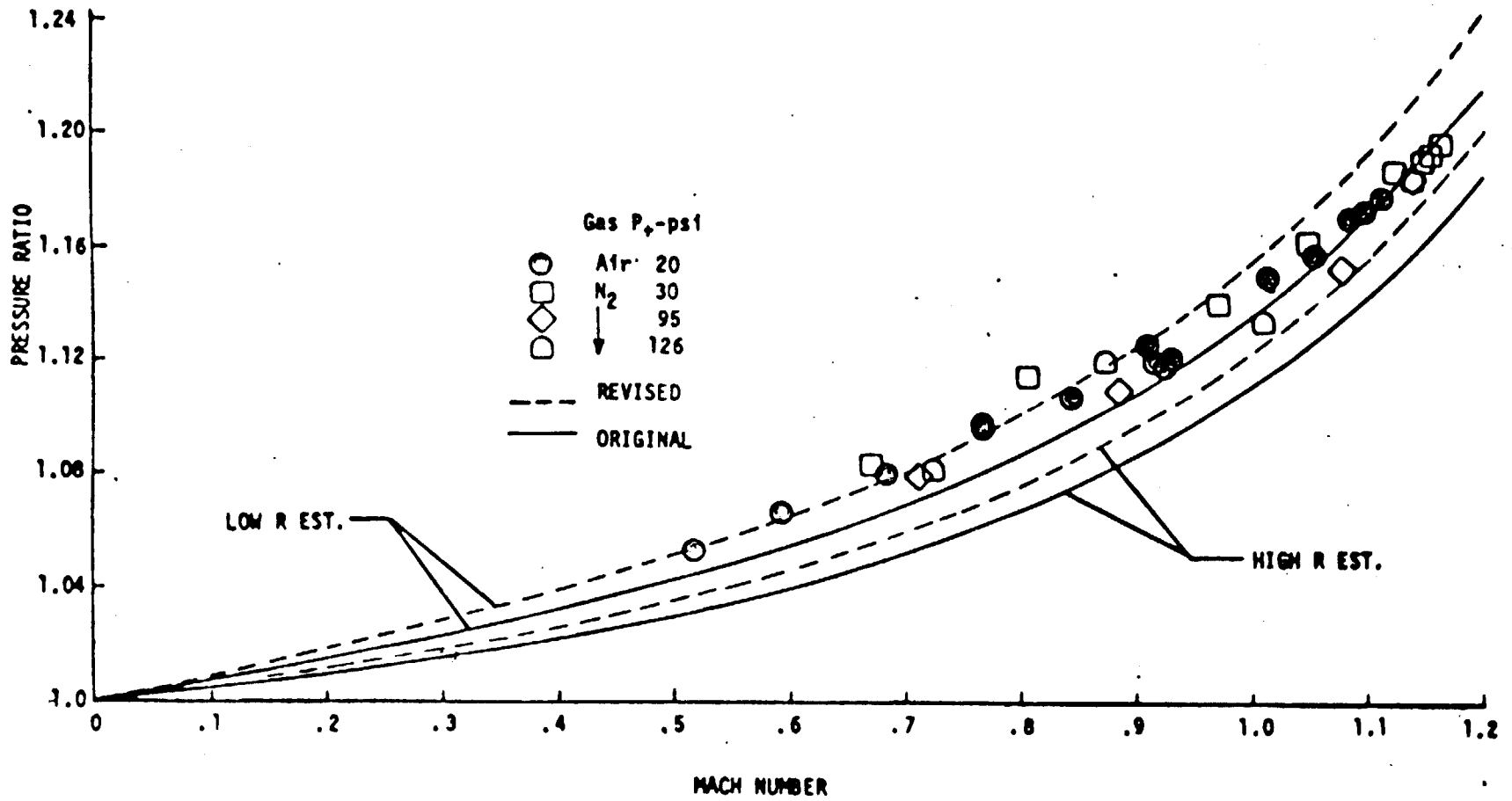



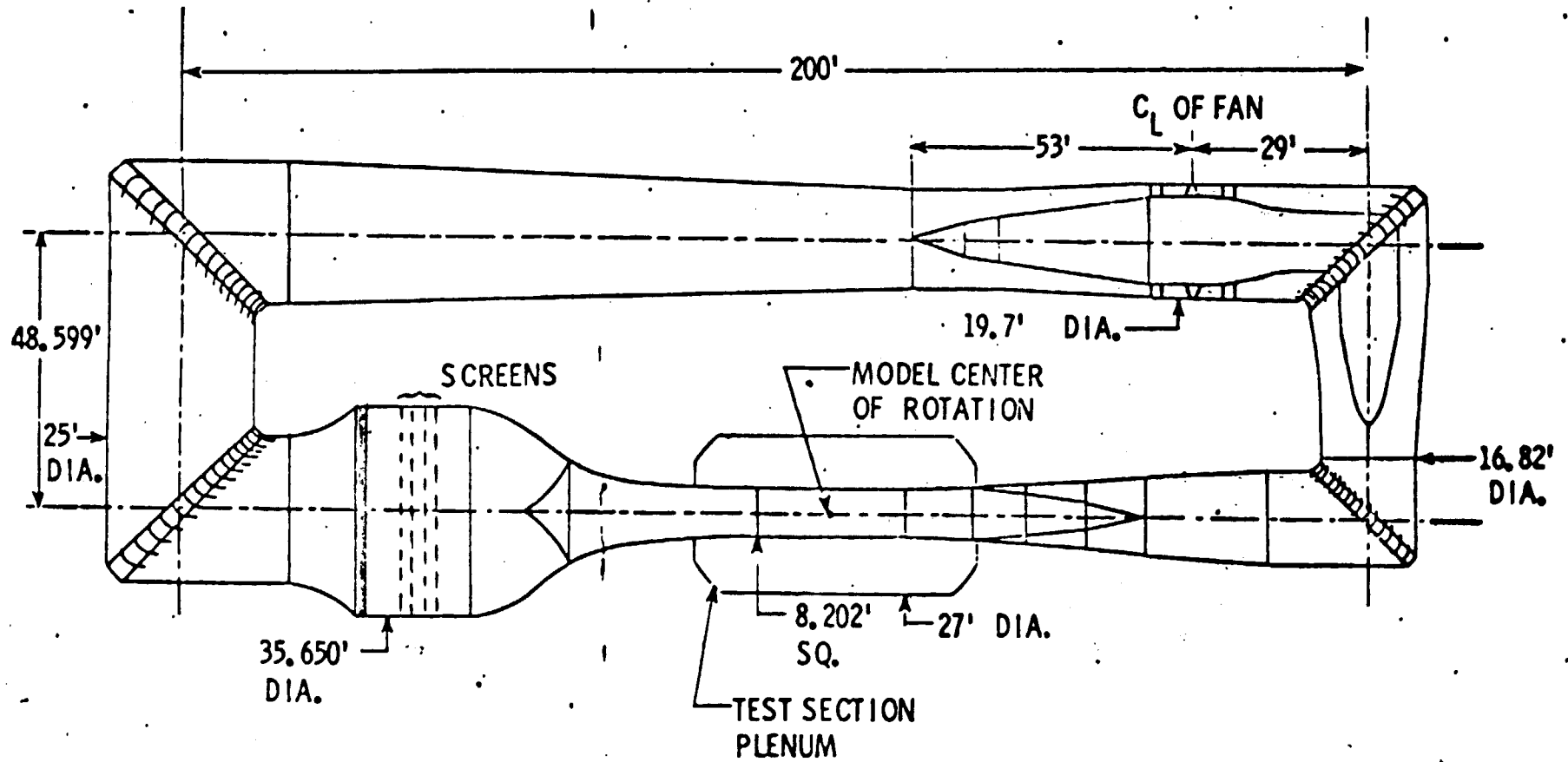

NATIONAL TRANSONIC FACILITY

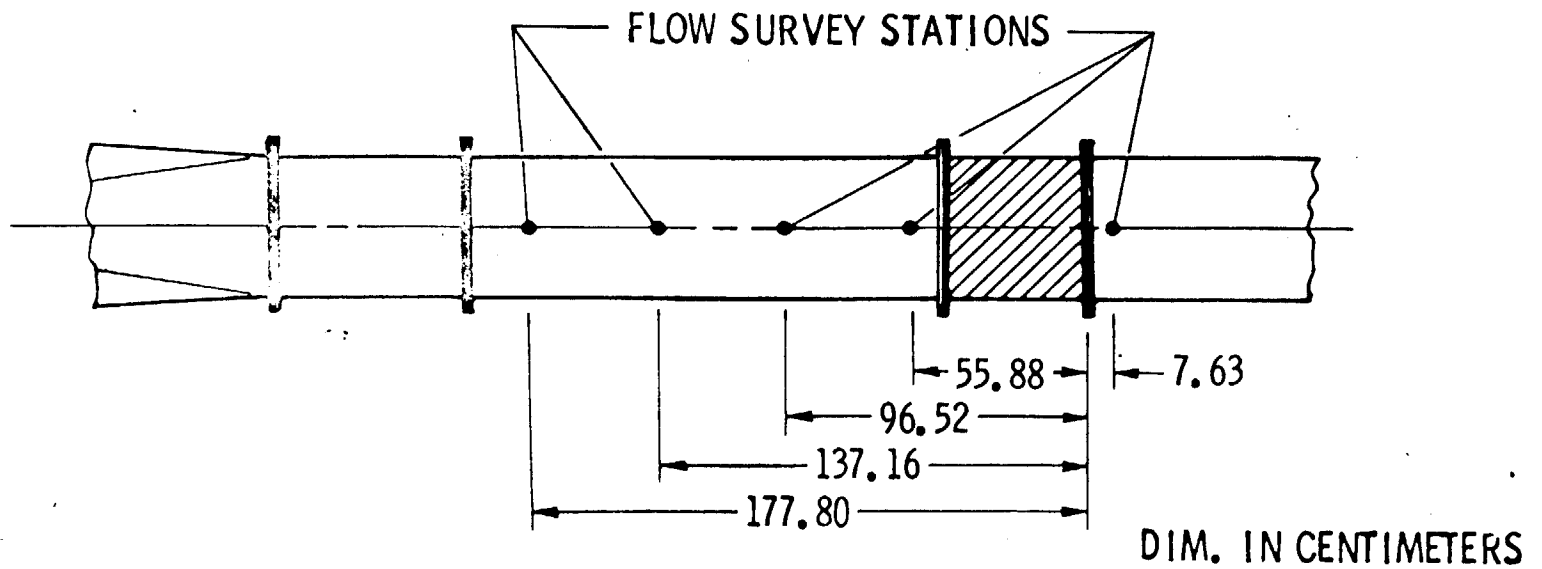
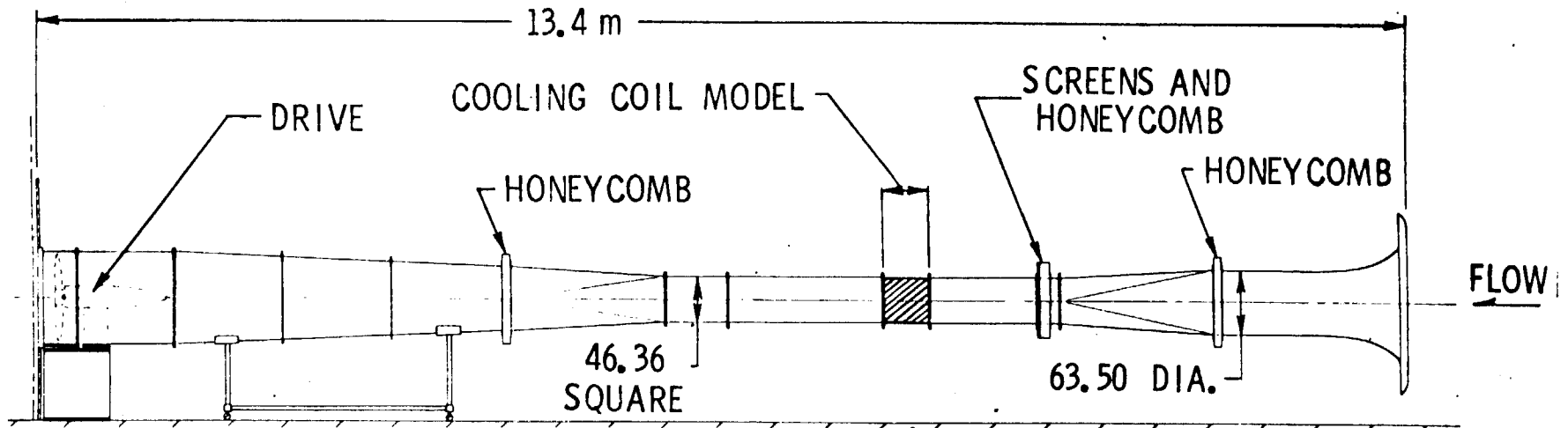

SCHEMATIC OF FLOW APPARATUS

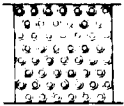
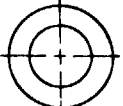
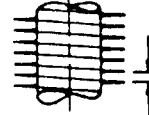
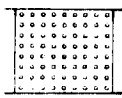

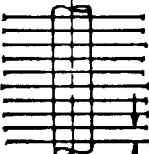
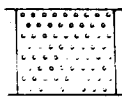
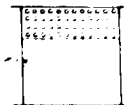







TEST MODELS

Model	Tube Geometry			Fin Geometry	Porosity	RN Range**	Test Facility
	Spacing*	Placement	Size*				
1	8 ROWS STAGGERED 6.05 x 6.99 ON CENTERS		2.84 O.D.  ROUND	SPIRAL  0.508	0.55	2×10^4 TO 3×10^5	FLOW APPARATUS
2	8 ROWS INLINE 5.08 x 5.08 ON CENTERS		1.59 O.D.  ROUND	PLATE  0.64	0.65		
3	8 ROWS STAGGERED 5.08 x 5.08 ON CENTERS						
4	4 ROWS INLINE 3.81 x 3.81 ON CENTERS		1.59 O.D.  ROUND	PLATE  0.25	0.53		

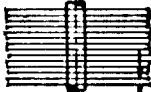
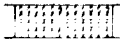
* ALL DIMENSIONS IN CENTIMETERS

** RN PER FOOT

TEST MODELS (CONTINUED)

Model	Tube Geometry			Fin Geometry	Porosity	RN Range**	Test Facility
	Spacing*	Placement	Size*				
5	4 ROWS INLINE 3.81 x 3.81 ON CENTER		0.79 x 1.59  ELLIPSE	PLATE  0.25	0.71	2×10^4 TO 3×10^5	FLOW APPARATUS
6			1.14 x 2.27  ELLIPSE	PLATE  0.25			
7			1.59 O.D.  ROUND	PLATE  0.42			

* ALL DIMENSIONS IN CENTIMETERS

** RN PER FOOT

TYPICAL MODELS FOR FLOW APPARATUS

MODEL NO. 1
SPIRAL FIN

MODEL NO. 2
PLATE FIN

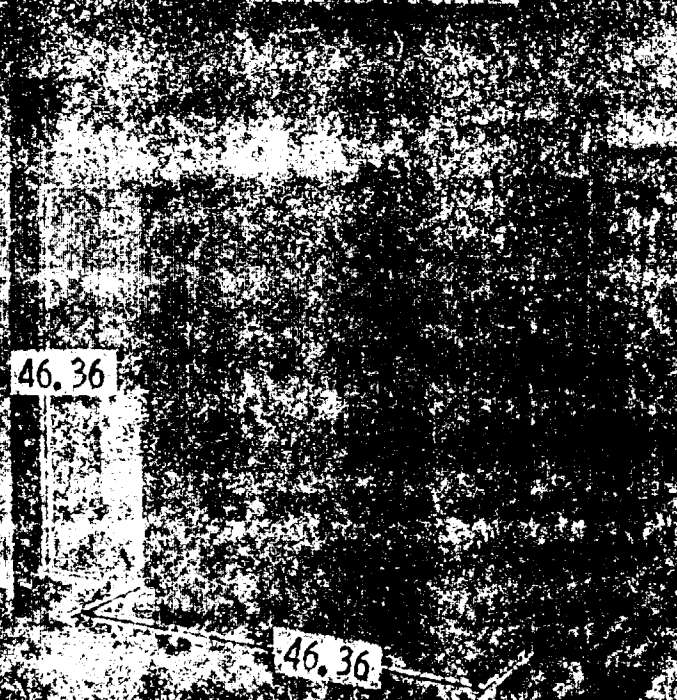
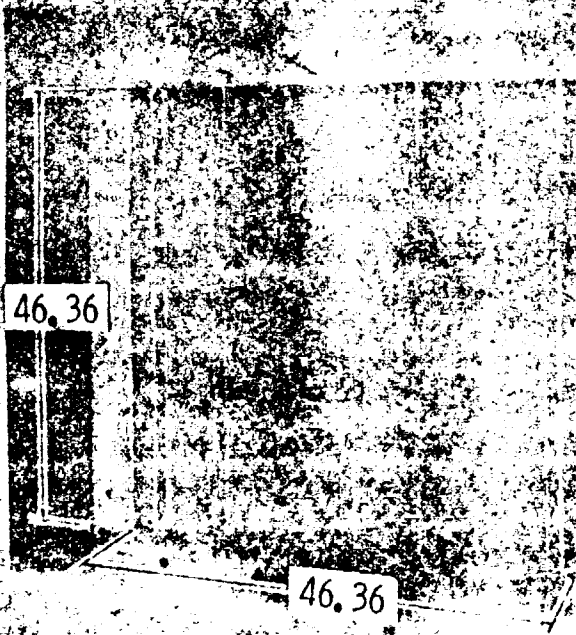

ORIGINAL PAGE IS
OF POOR QUALITY

VARIATION OF PRESSURE LOSS WITH REYNOLDS NUMBER

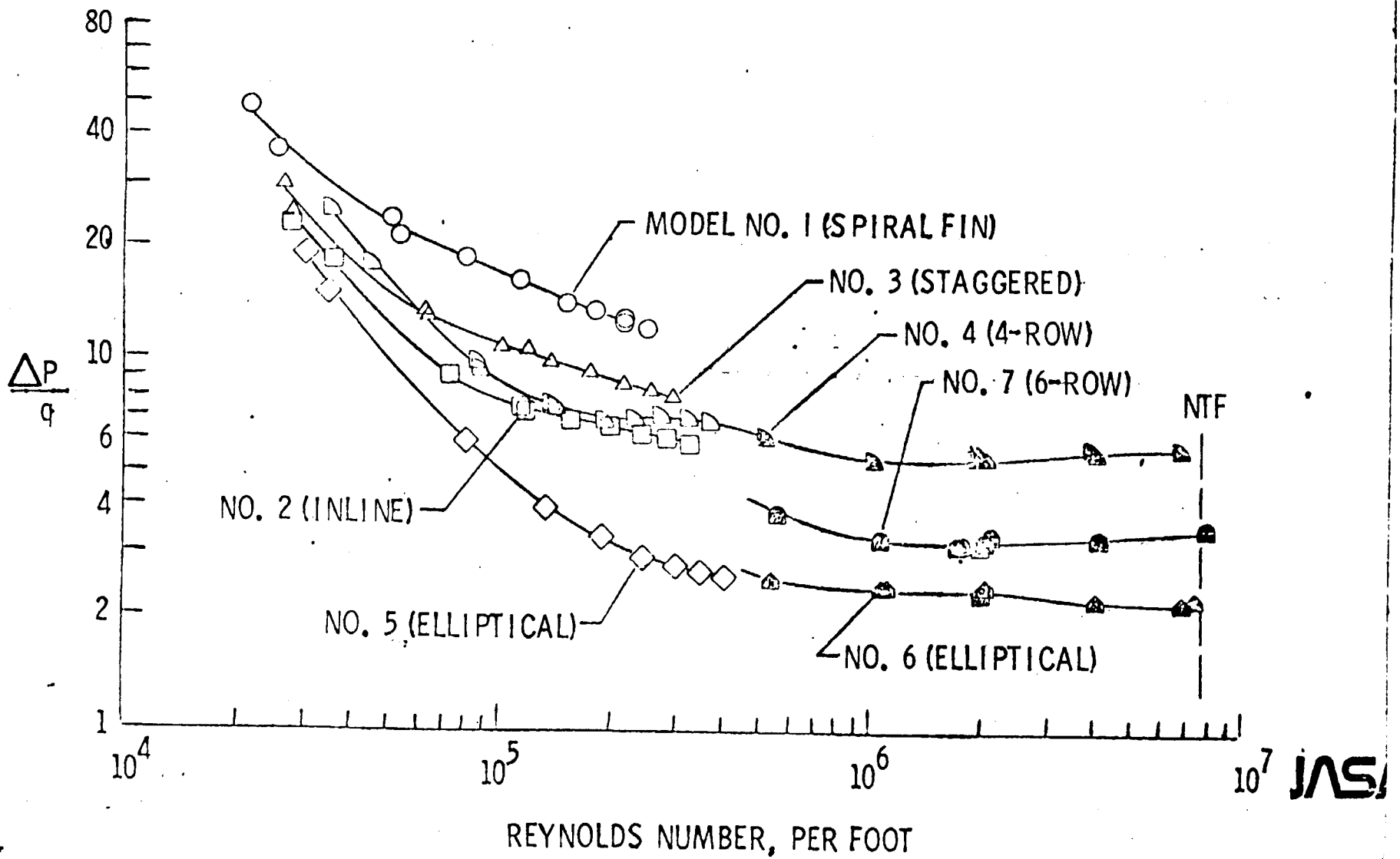

VARIATION OF LONGITUDINAL TURBULENCE COMPONENT WITH REYNOLDS NUMBER

(177.8 CM DOWNSTREAM OF MODEL FACE)

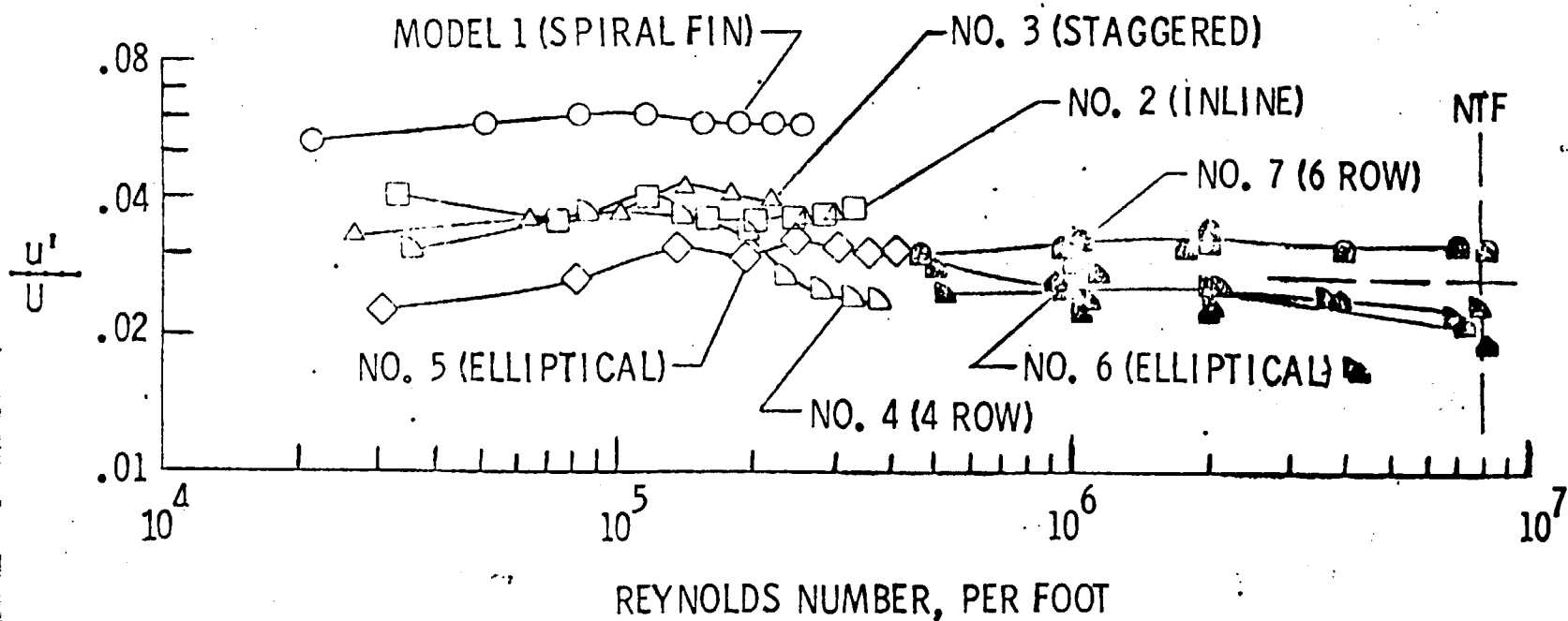

NASA

NASA LANGLEY RESEARCH CENTER

COOLING COIL AERODYNAMIC REQUIREMENTS

$$\bullet \frac{\Delta P_i}{q} \leq 5$$

• DOWNSTREAM TURBULENCE $\leq .026$

• HEAT CAPACITY CORRESPONDING TO $M = 1.0 @ P_T = 2 \text{ ATMOS.}$
 $T_T = 150^\circ \text{F, HP} = 47,000$

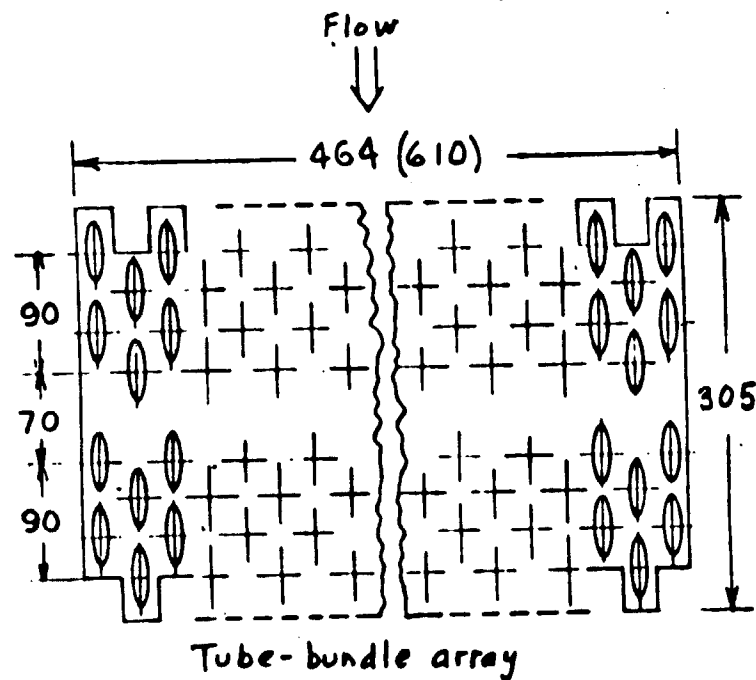
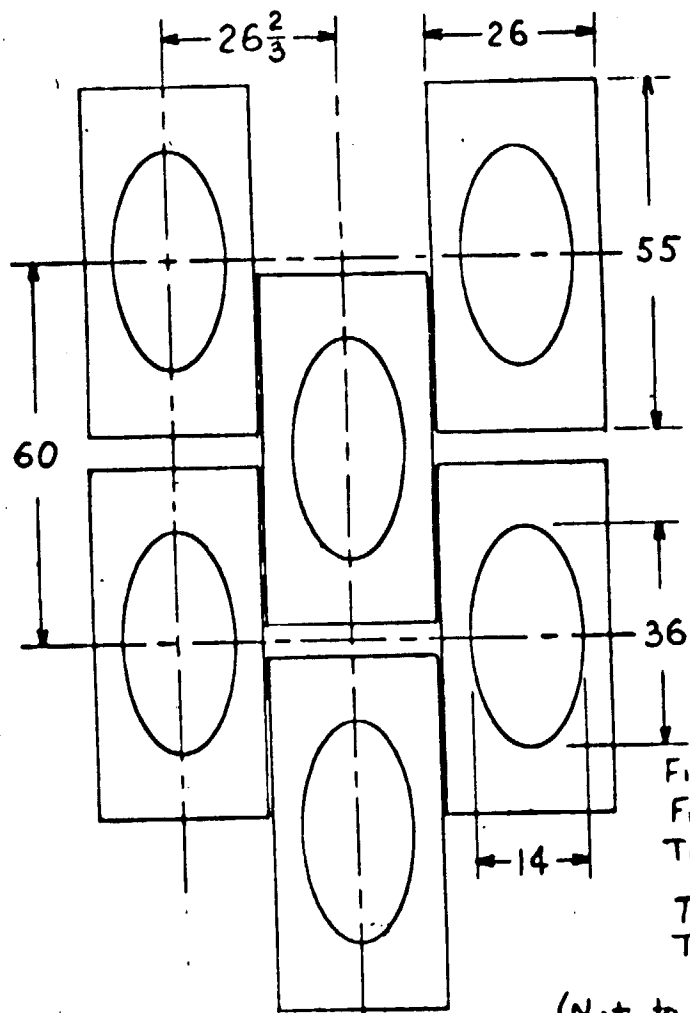

Fin thickness .25 mm
 Fin spacing 3 mm
 Tube hydraulic diam. 19.2 mm

Tube-bundle length in dir. of tube axis 464 mm (184 mm)
 Tube-bundle porosity .437

(Not to scale)

Geometry of tube-bundle model for ambient temperature flow apparatus. Dimensions in parentheses apply to 0.3m TCT model. All dimens. in mm

RACA
L-81-2109

NTF-GEA TUBE BUNDLE MODEL

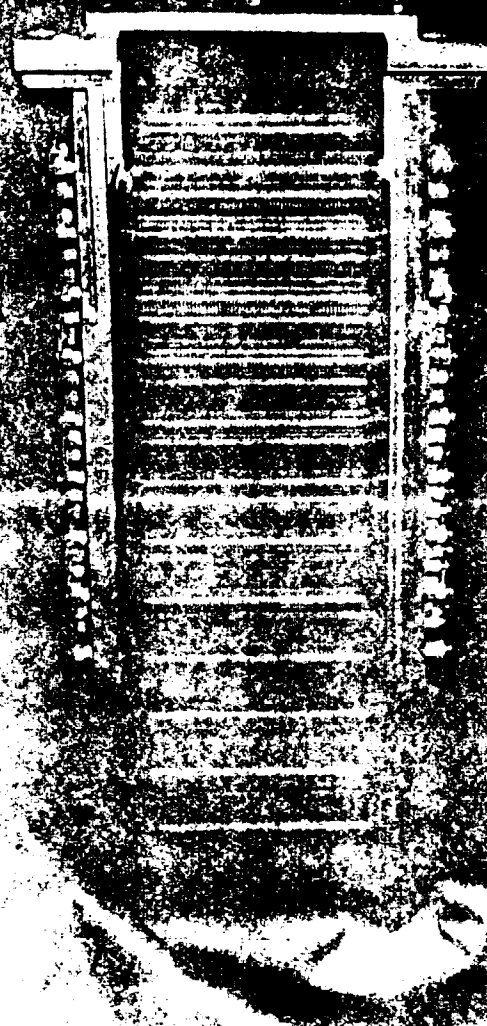

ORIGINAL PAGE IS
OF POOR QUALITY

NTF-GEA COOLING COIL TEST
IN 0.3 m CRYOGENIC TUNNEL

TUBE BUNDLE MODEL

FLOW

TOTAL
PRESSURE
RAKE

ORIGINAL PAGE IS
OF POOR QUALITY

NASA
L-81-1702

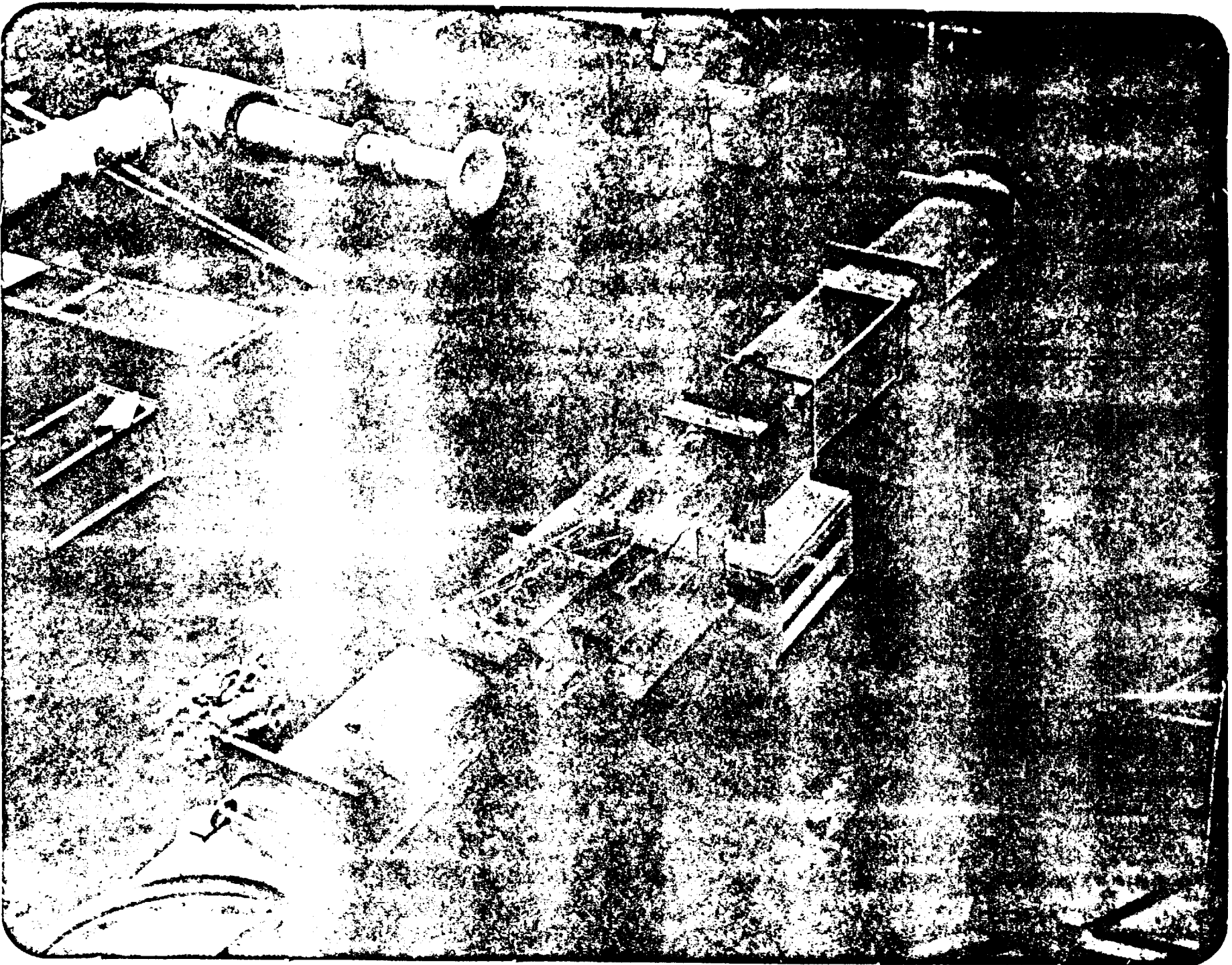

ORIGINAL PAGE IS
OF POOR QUALITY

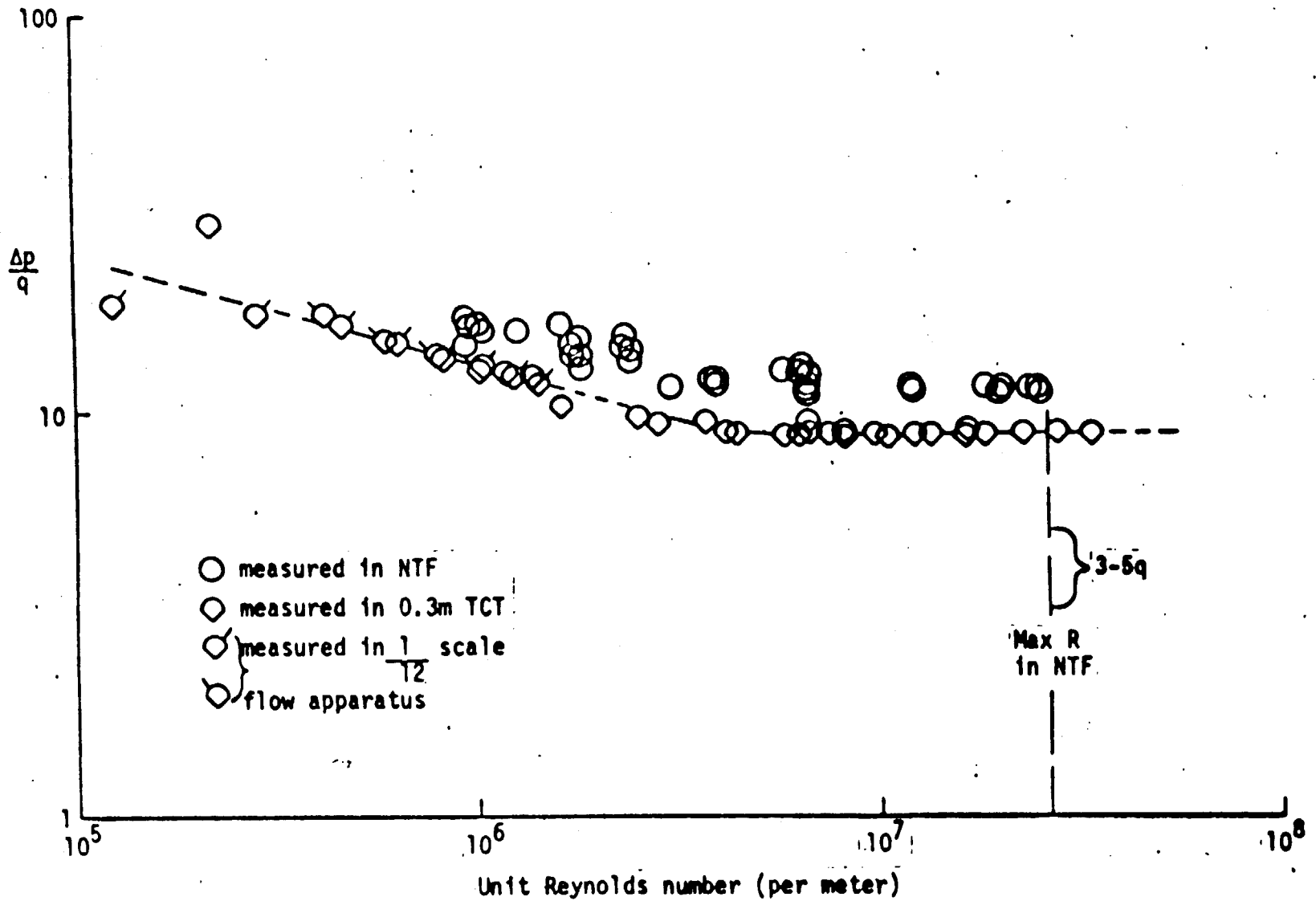

Pressure loss coefficient vs. unit Reynolds number for the NTF-GEA heat exchanger.

VARIATION OF PRESSURE LOSS WITH REYNOLDS NUMBER

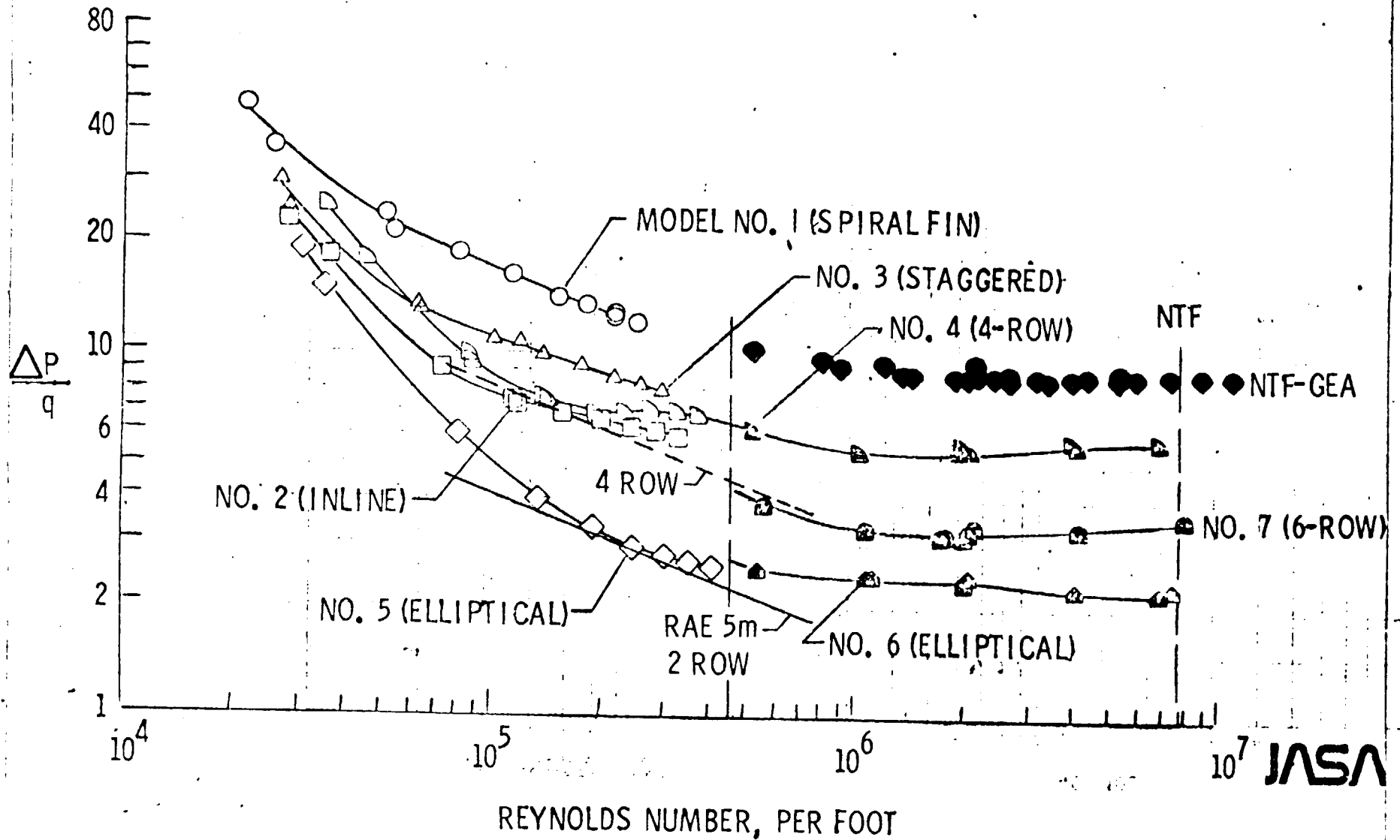

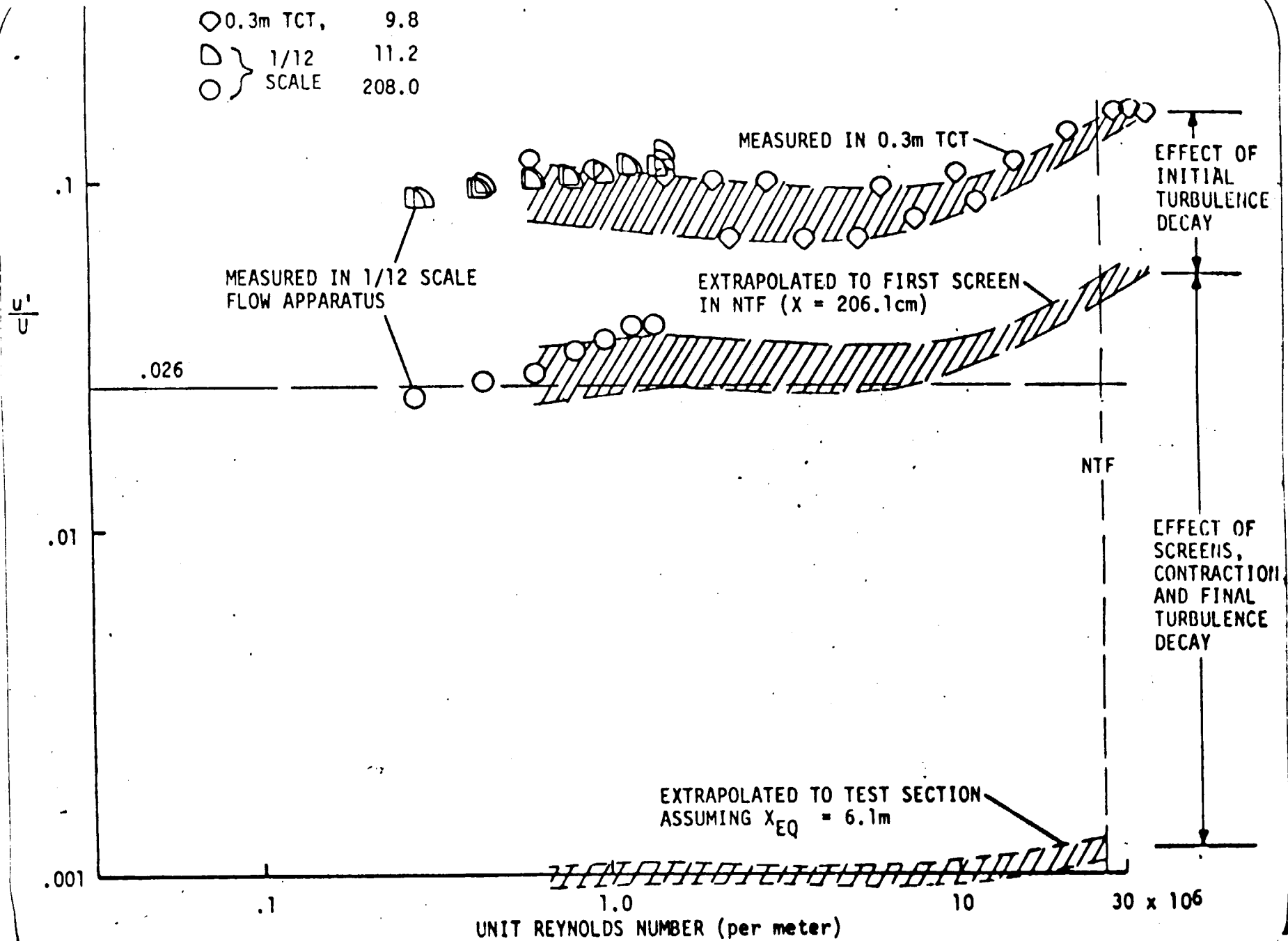
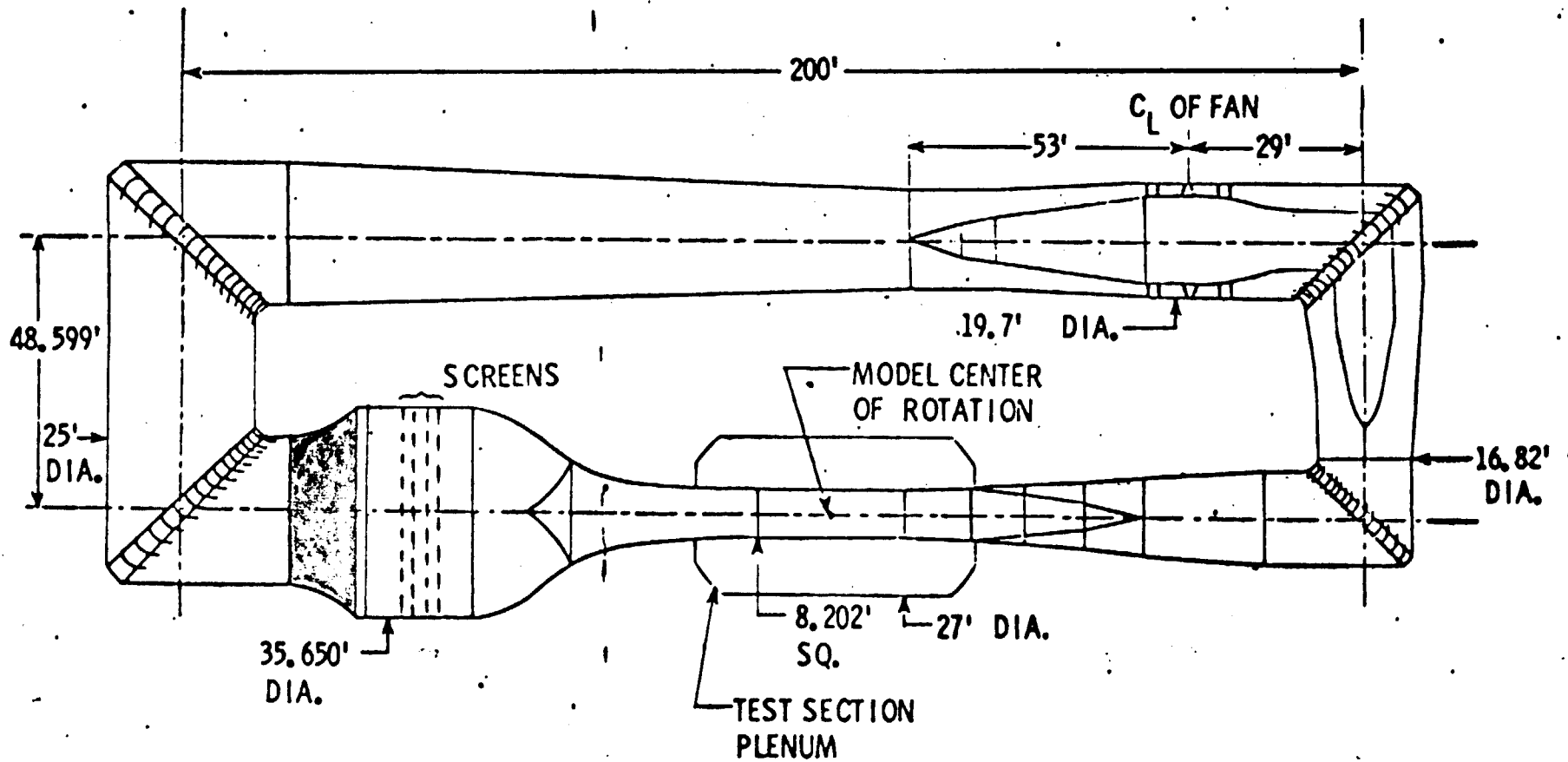
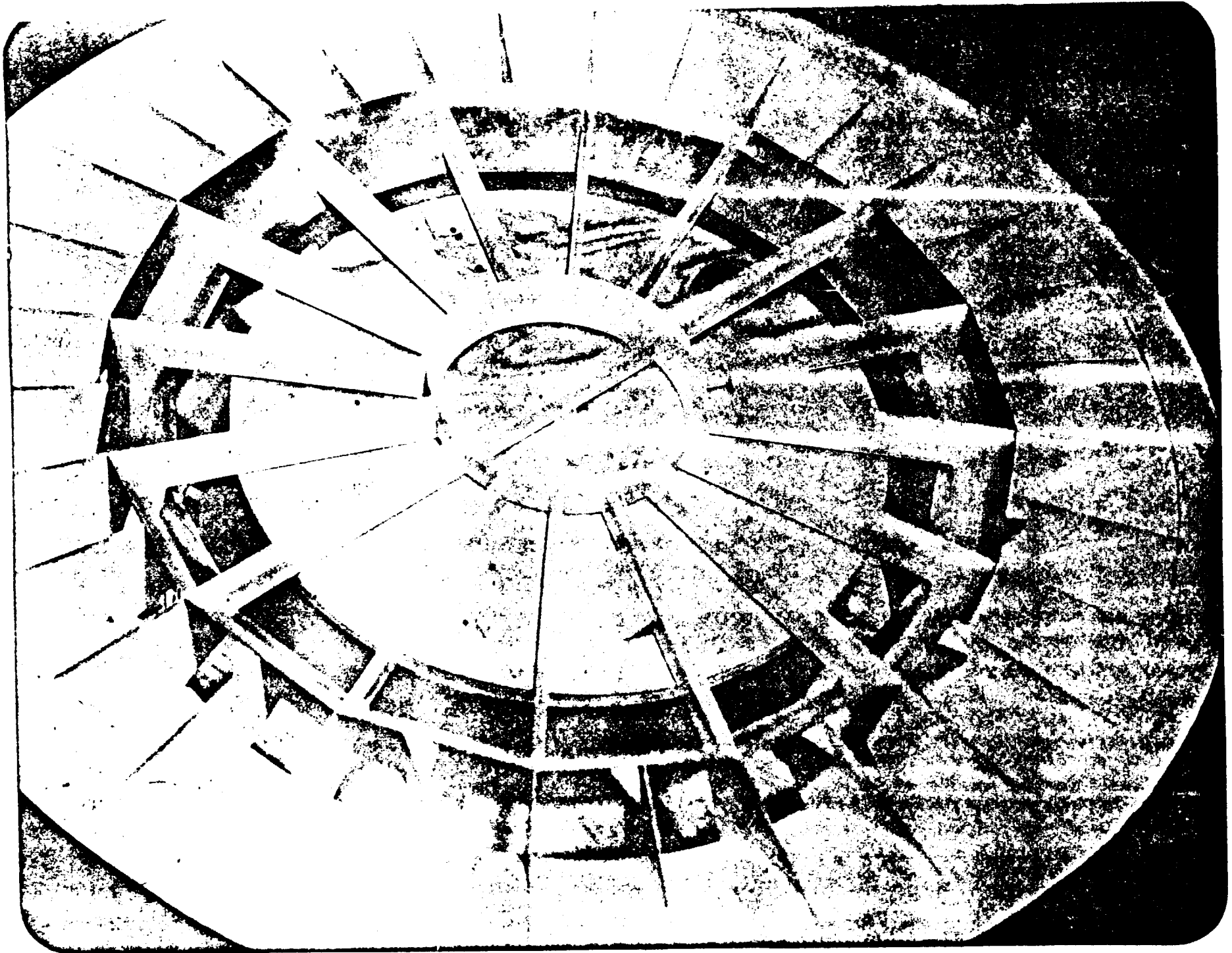

FIGURE 3: LONGITUDINAL COMPONENT OF TURBULENCE (rms) FOR THE NTF-GEA HEAT EXCHANGER.

NATIONAL TRANSONIC FACILITY



ORIGINAL PAGE IS
OF POOR QUALITY



NASA LANGLEY RESEARCH CENTER

RAPID DIFFUSER PERFORMANCE (NTF)

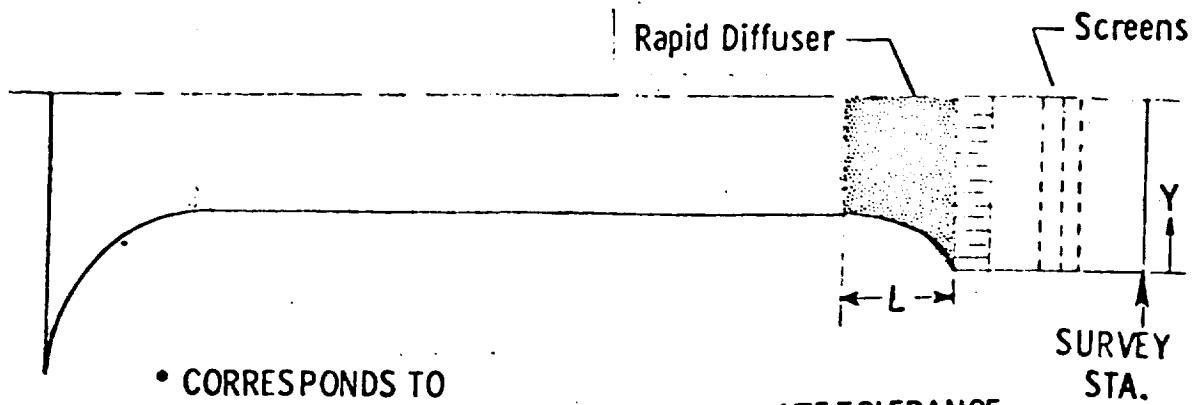

• CORRESPONDS TO
.001 IN TEST SECTION

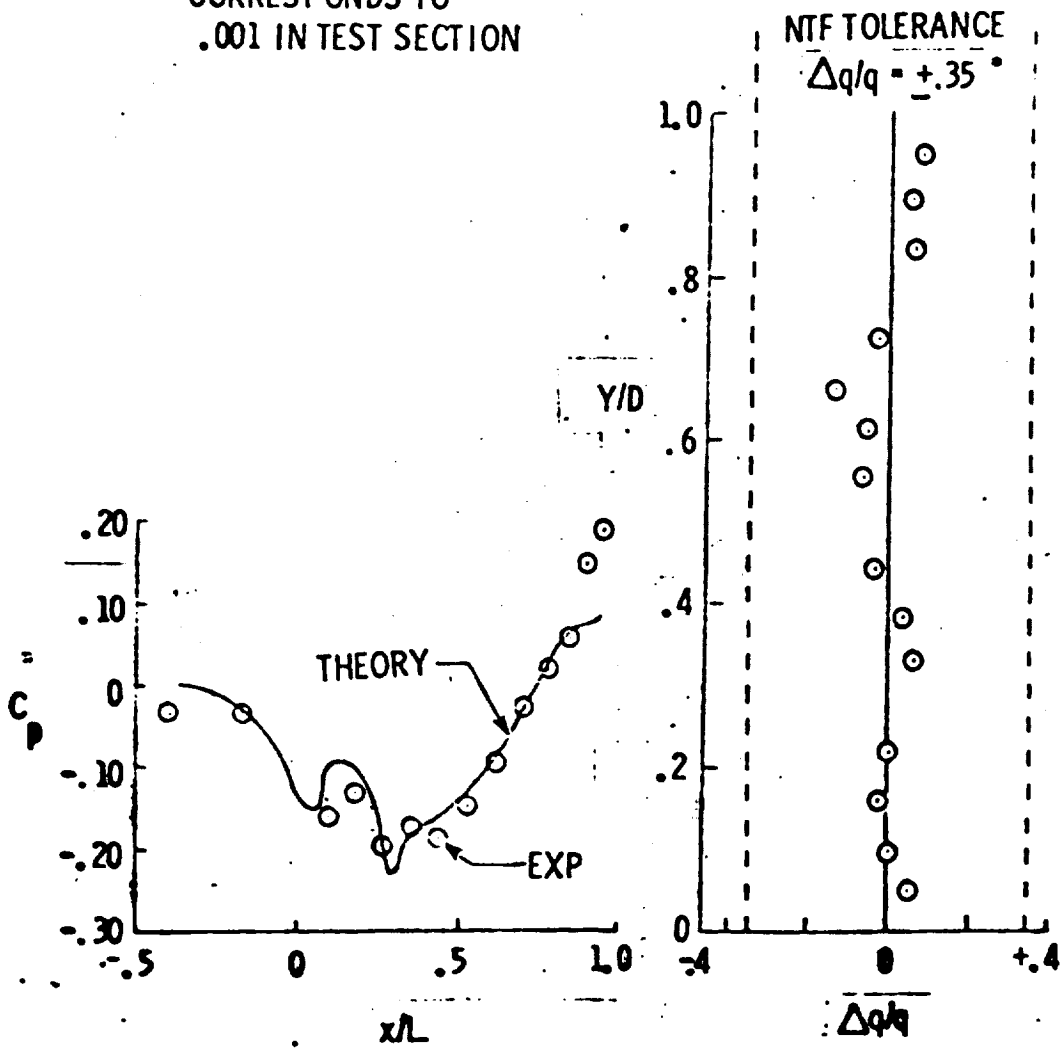

EFFECT OF DISTORTED INLET VELOCITY PROFILE ON RAPI DIFFUSER PERFORMANCE

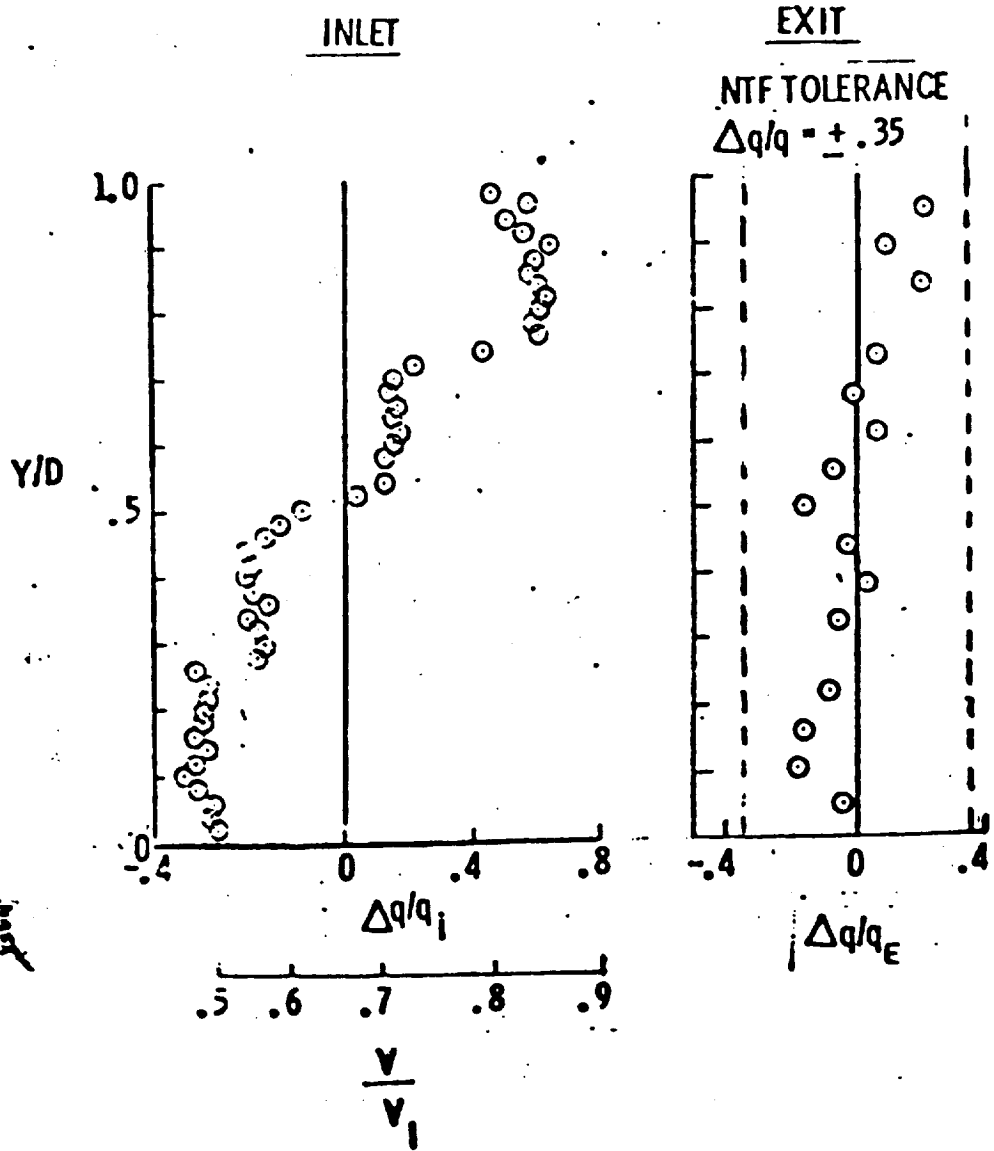
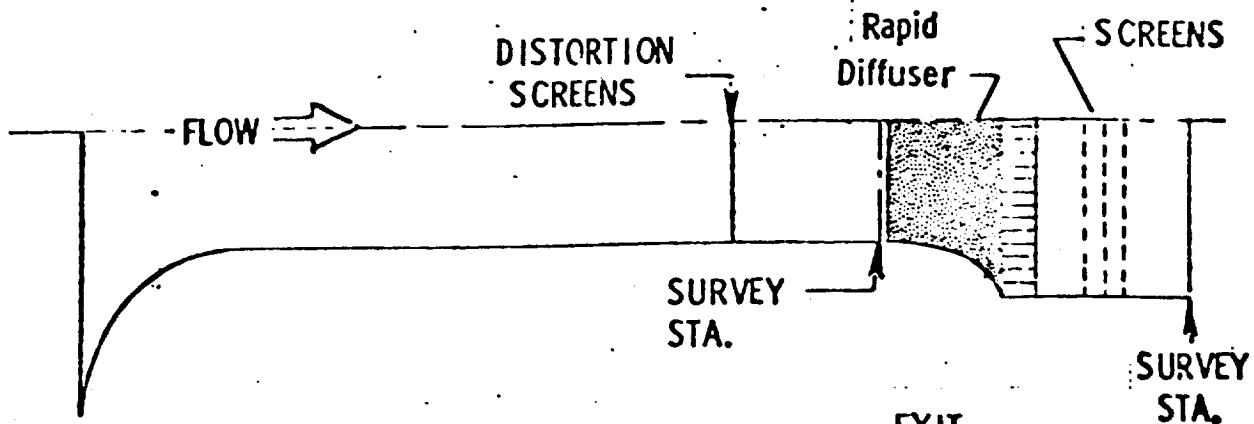

NASA LANGLEY RESEARCH CENTER

NATIONAL TRANSONIC FACILITY

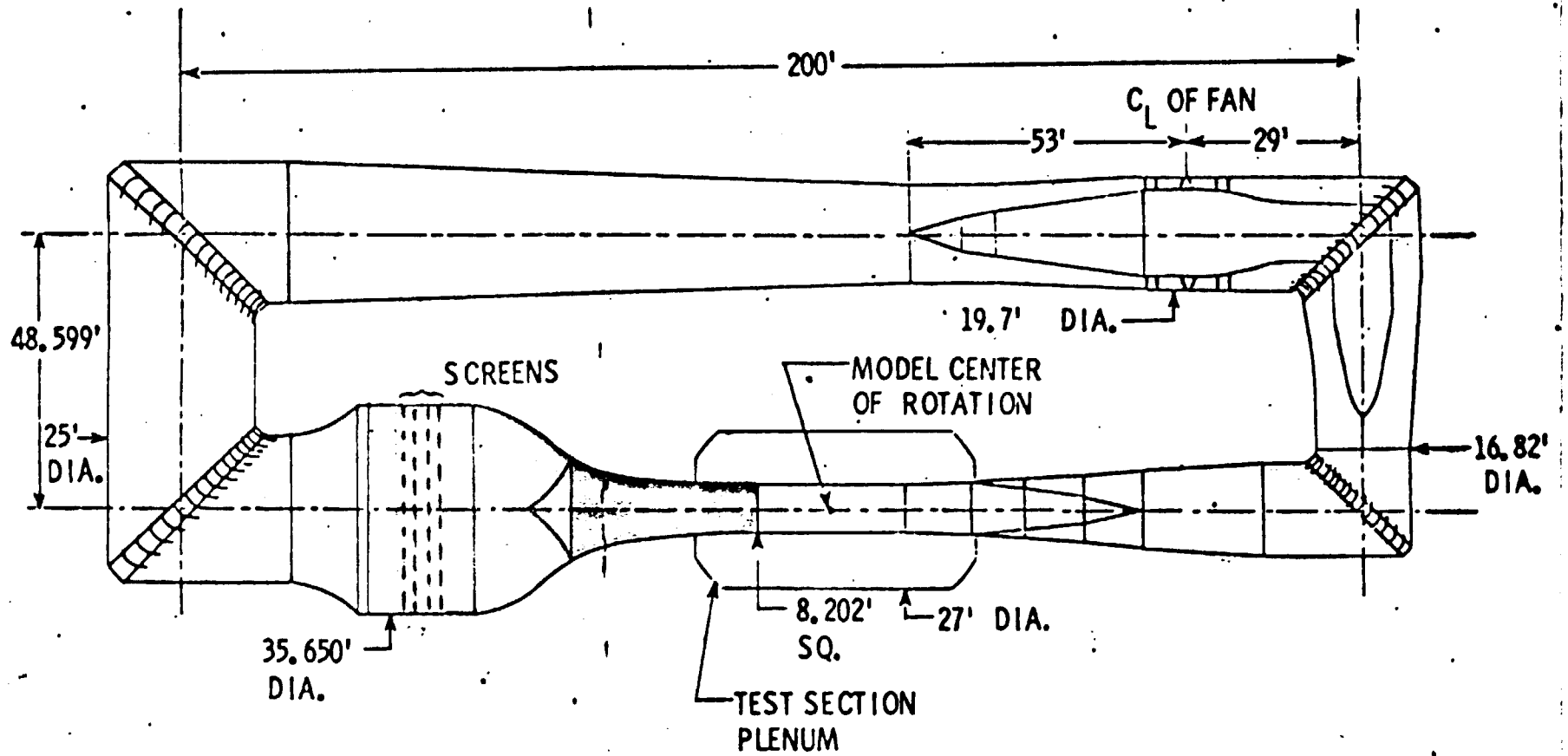

EFFECTS OF CONTRACTION RATIO

$M = 1$

REF. AGARD
AR-33

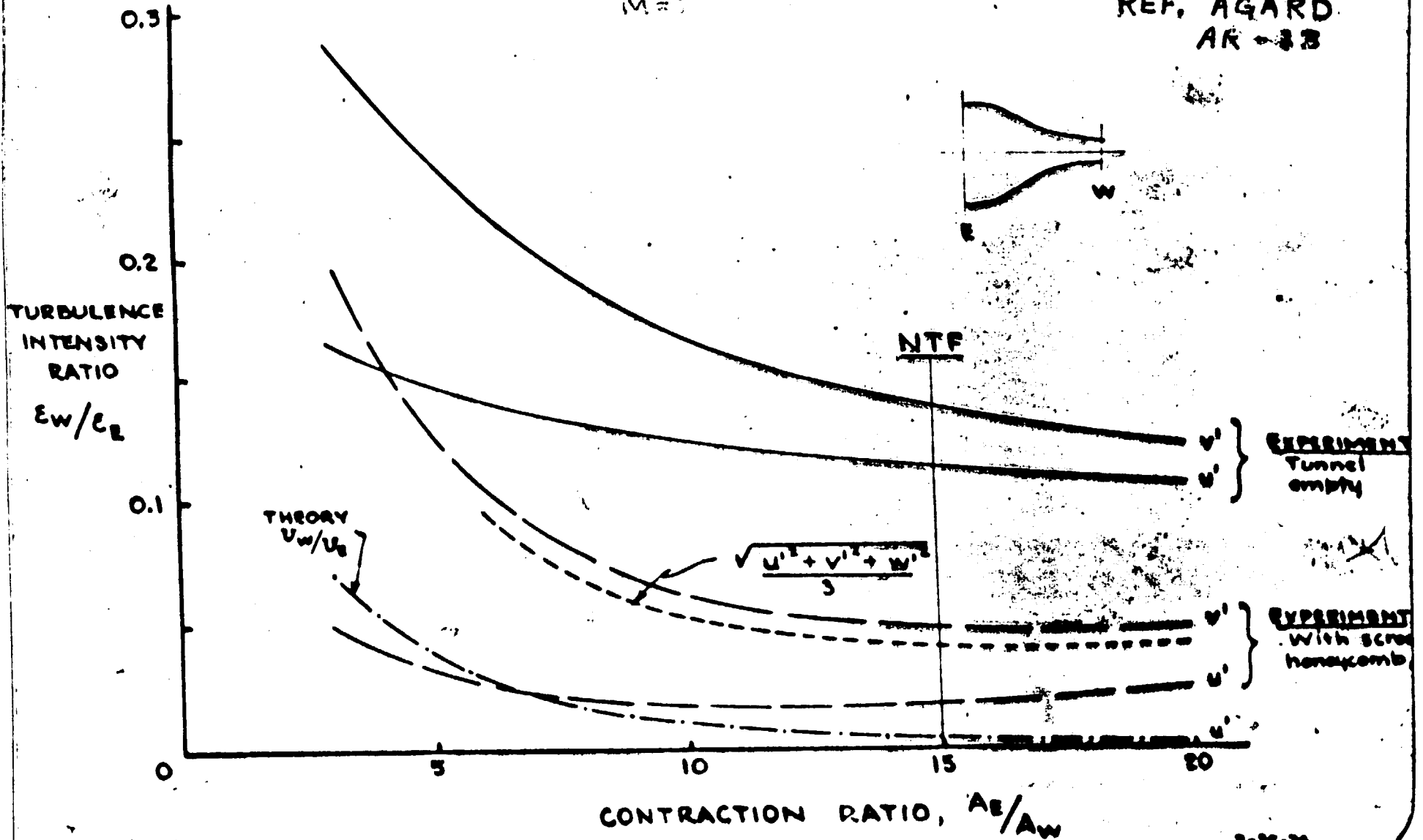

ORIGINAL PAGE IS
OF POOR QUALITY

8-15-76

COMPARISON OF THEORY AND EXPERIMENT

(TURB)_{SC} = .017, C.R. = 6.6, WIRE DIA. = .011 INCH

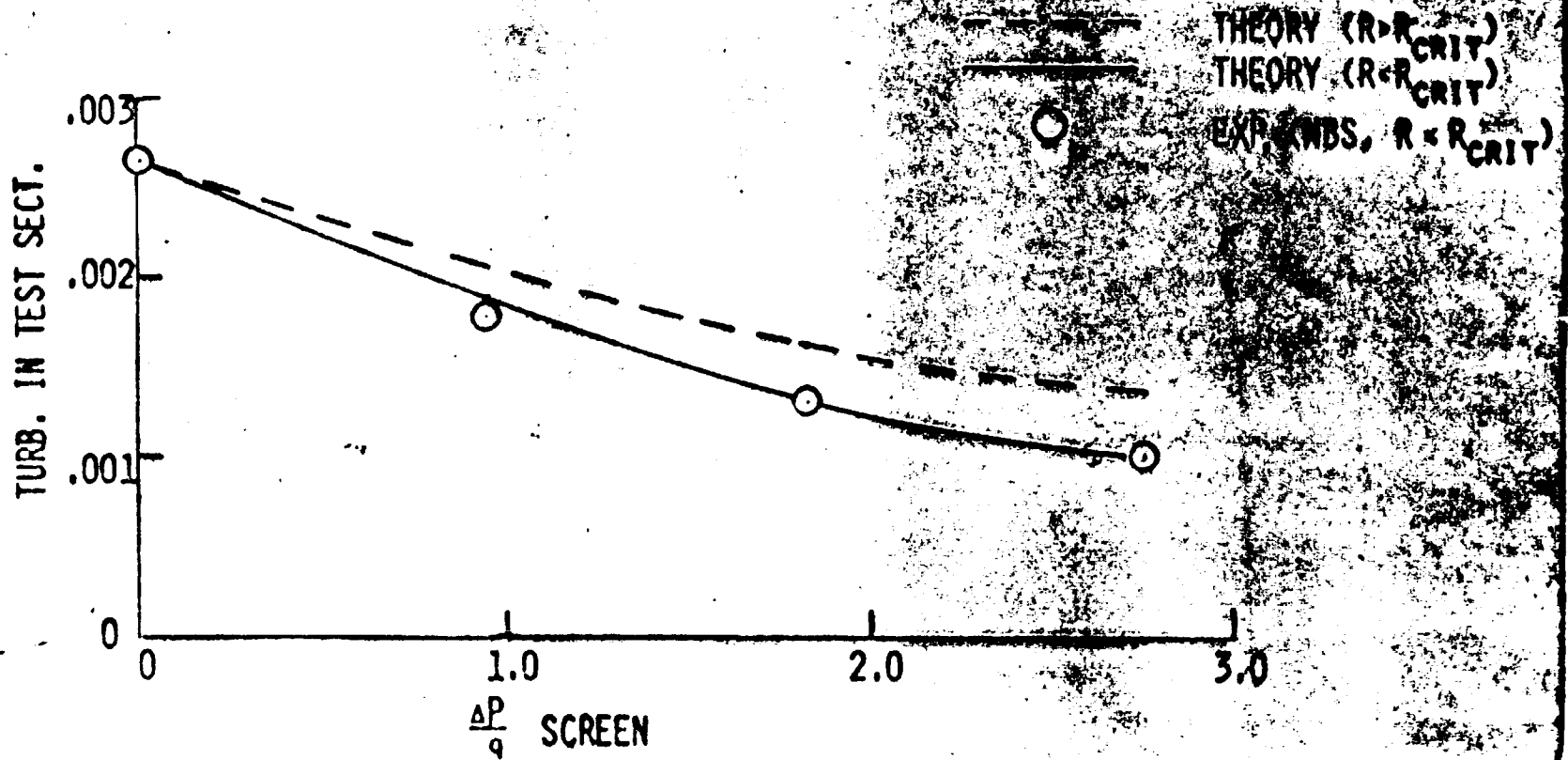

EFFECT OF CONTRACTION AND SCREENS ON TURBULENCE

$\mu_{TS} = 40$

$(TURB) SC = .017$

$\frac{(TURB) T.S.}{(TURB) S.C.}$

20

15

12

9

6

3

0

$\frac{\Delta P}{q}$ SCREENS

.5

1.0

1.5

NO SCREENS

5 SCREENS

(.000 WIRE)

$(TURB) T.S. = .001$

CONTRACTION RATIO

0

4

8

12

16

20

D-5

ORIGINAL PAGE IS
OF POOR QUALITY

EFFECT OF C.R. ON SCREEN STRESS AND HORSEPOWER
 (3 SCREENS .030 WIRE DIA. - 2 FT SAG)
 $M=1.0$ - P_T 130 PSIA

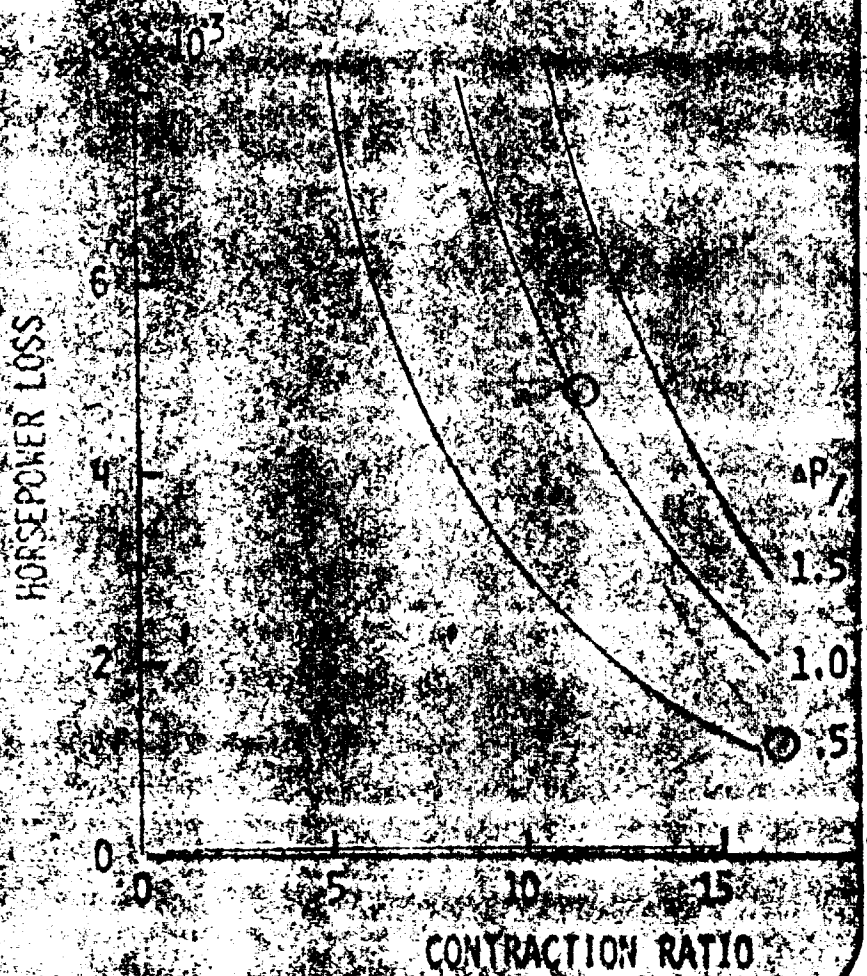
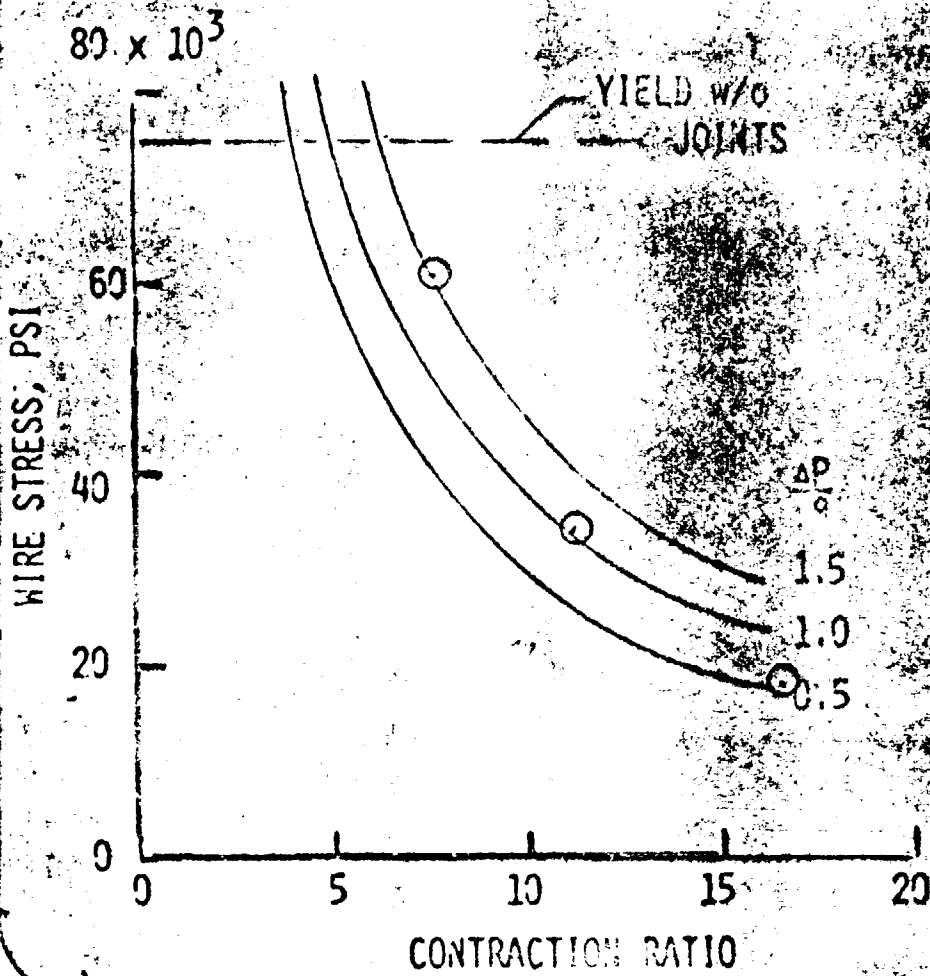

ORIGINAL PAGE IS
 OF POOR QUALITY

NTF CONTRACTION SECTION

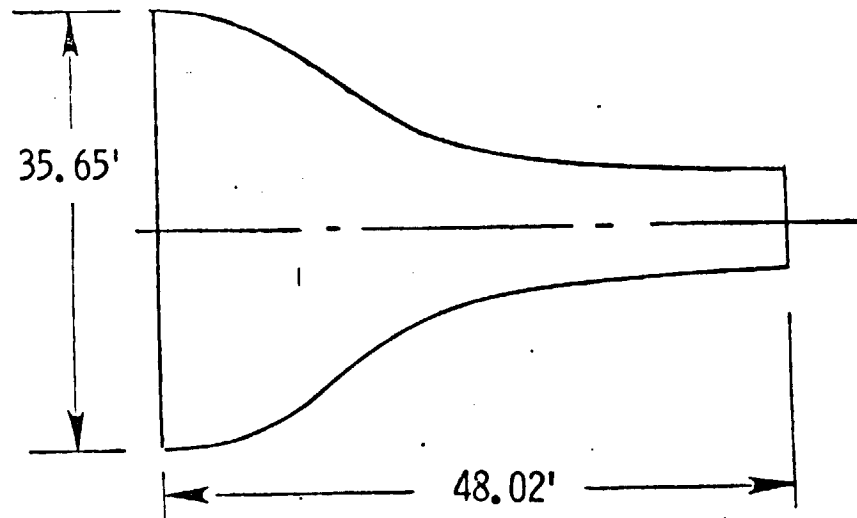

BASIS FOR DESIGN

● NASA TN D 7368

- Streamline Curvature Method for Axisymmetric Flow
- Compressible Flow
- Inviscid

● DESIGN CONDITIONS

- Minimum Length
- Weak Adverse Pressure Gradients at Start of Contraction
- Uniform Mach No. Distribution at Throat

VERIFICATION

● NASA CR-112239 - Streamtube Curvature Analysis

● EXPERIMENTAL STUDIES

- Flow Visualization
- Mach No. Distributions



EFFECT OF CONTRACTION LENGTH ON SEPARATION

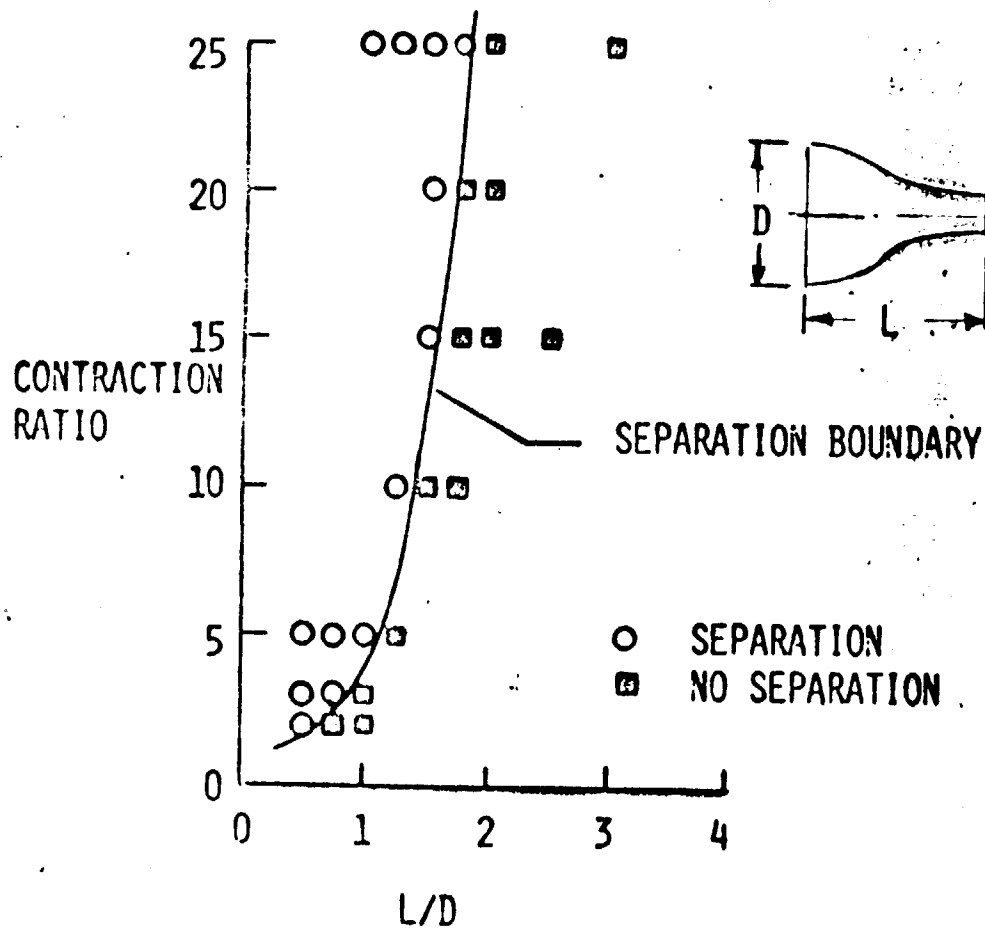

REF: J. ARICRAFT, AUG 74
BY CHMIELEWSKI

NTF CONTRACTION

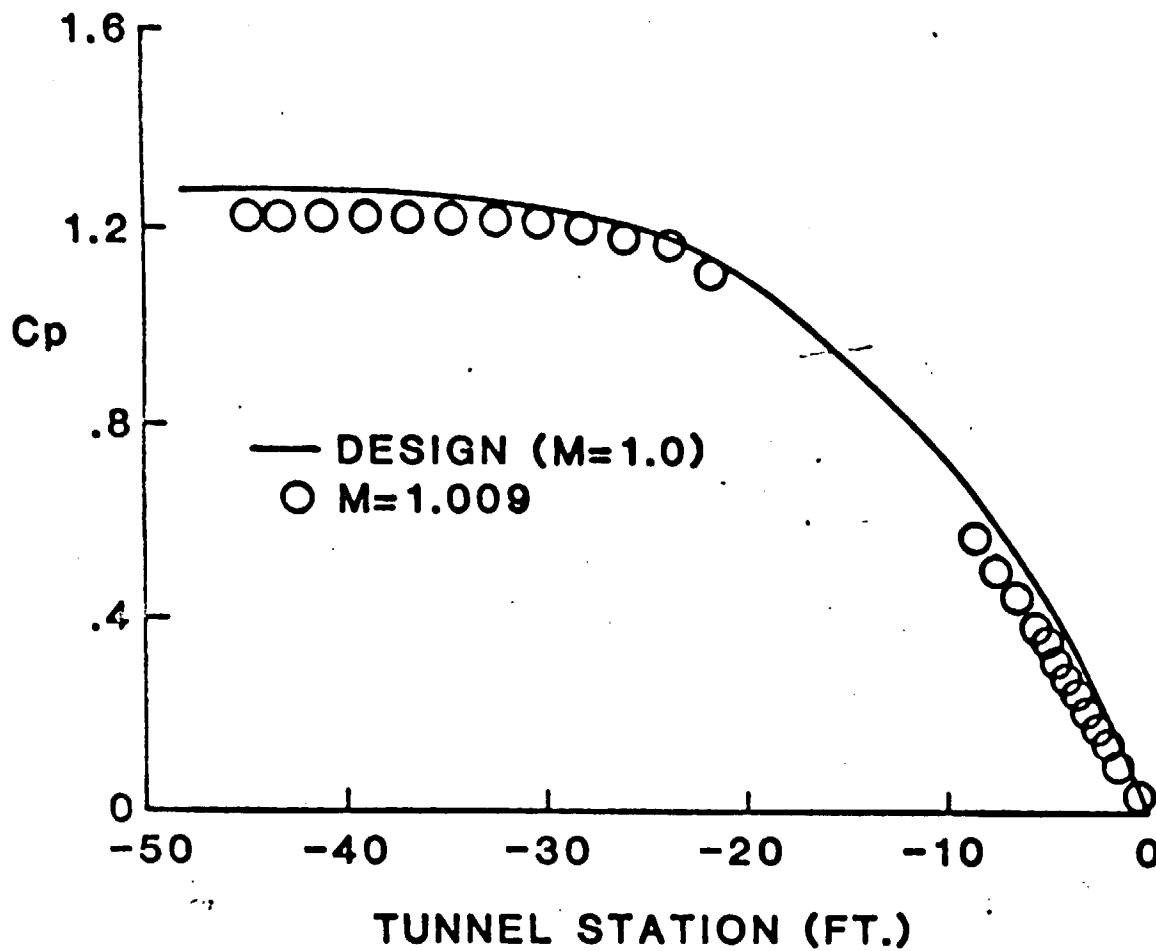

EFFECT OF NUMBER OF SCREENS

SOLIDITY = .34
(.032" wire; 6 per inch)

$$\frac{\Delta P}{q} = .75 \text{ per screen}$$

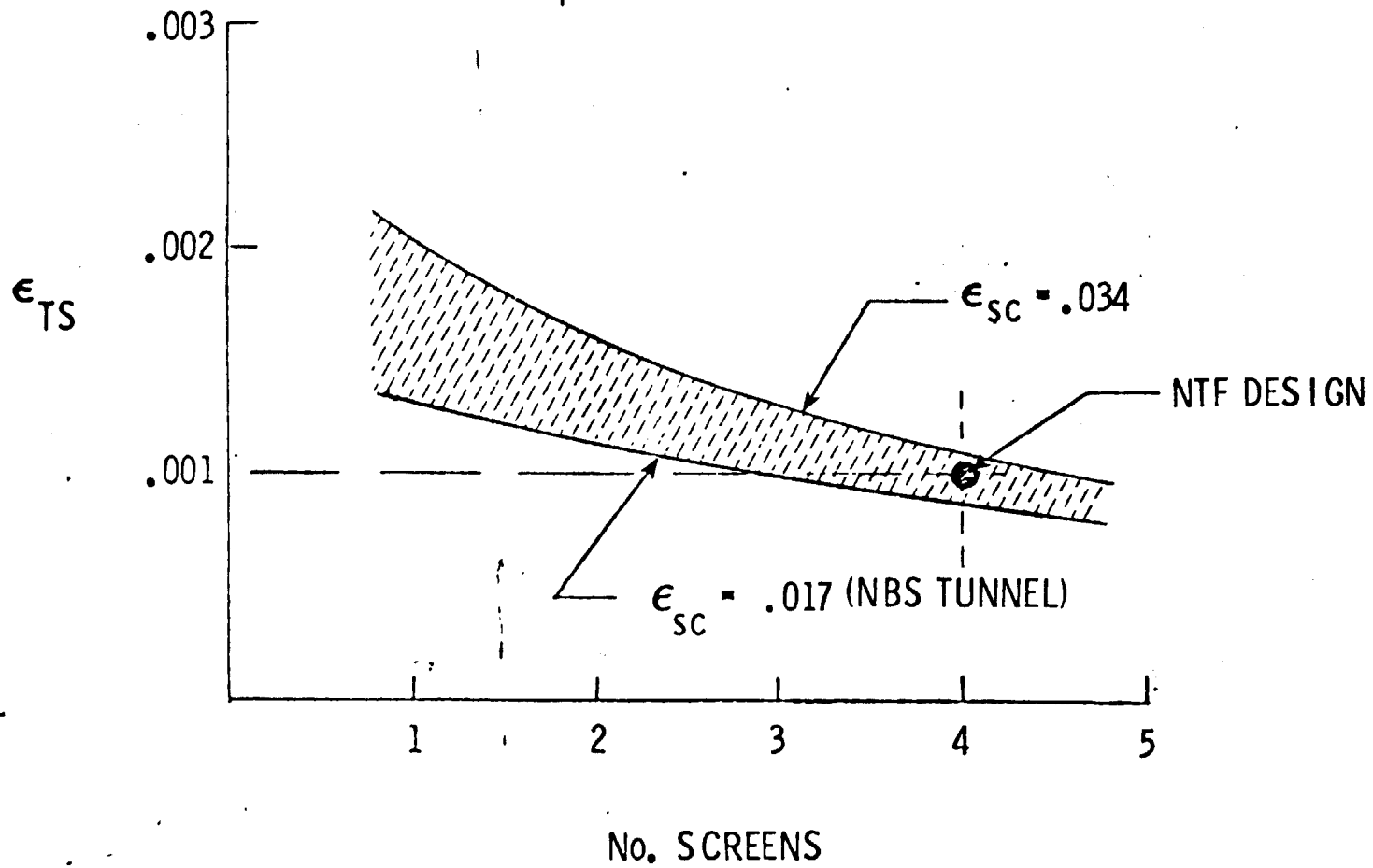

NATIONAL TRANSONIC FACILITY

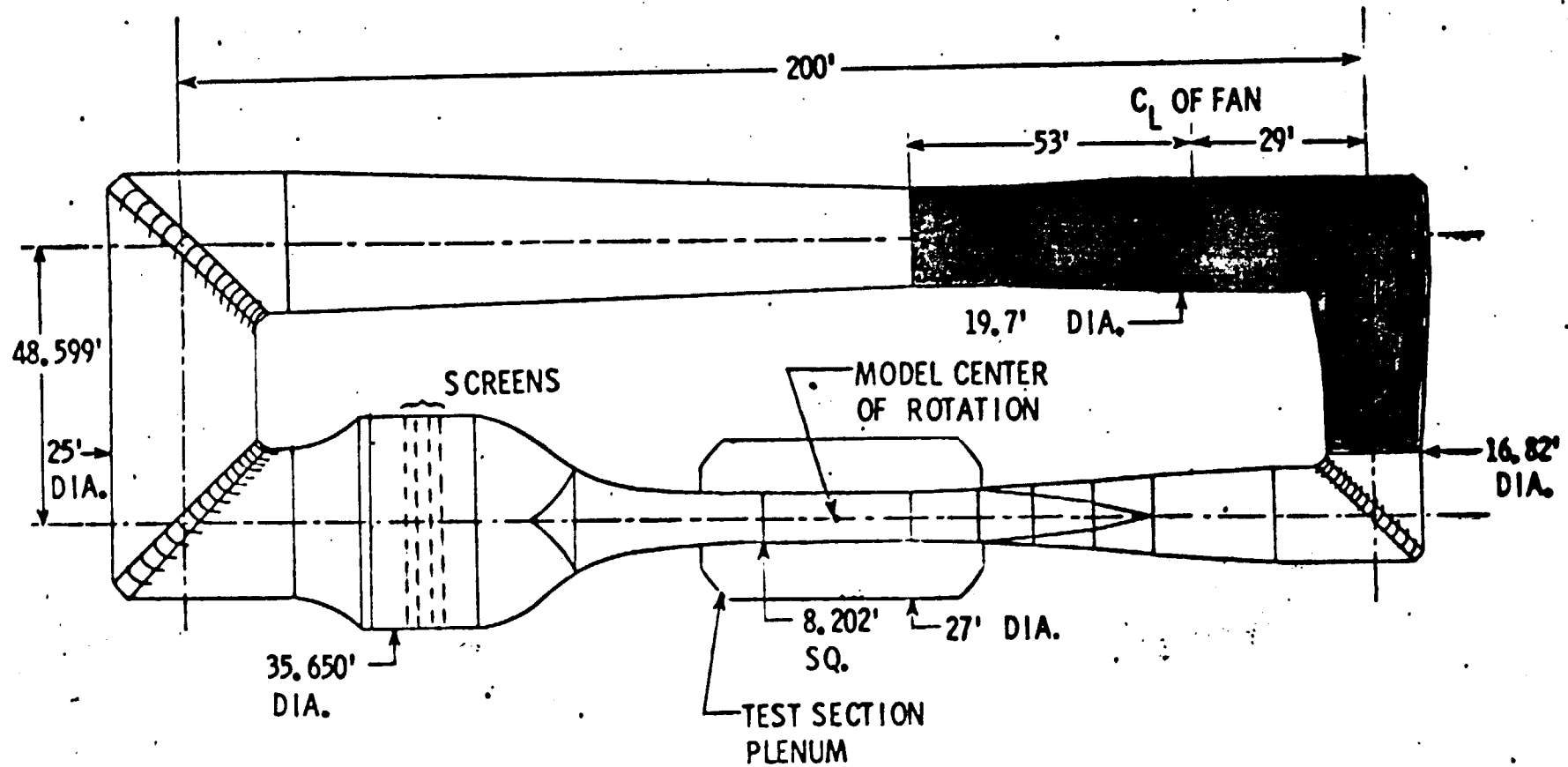

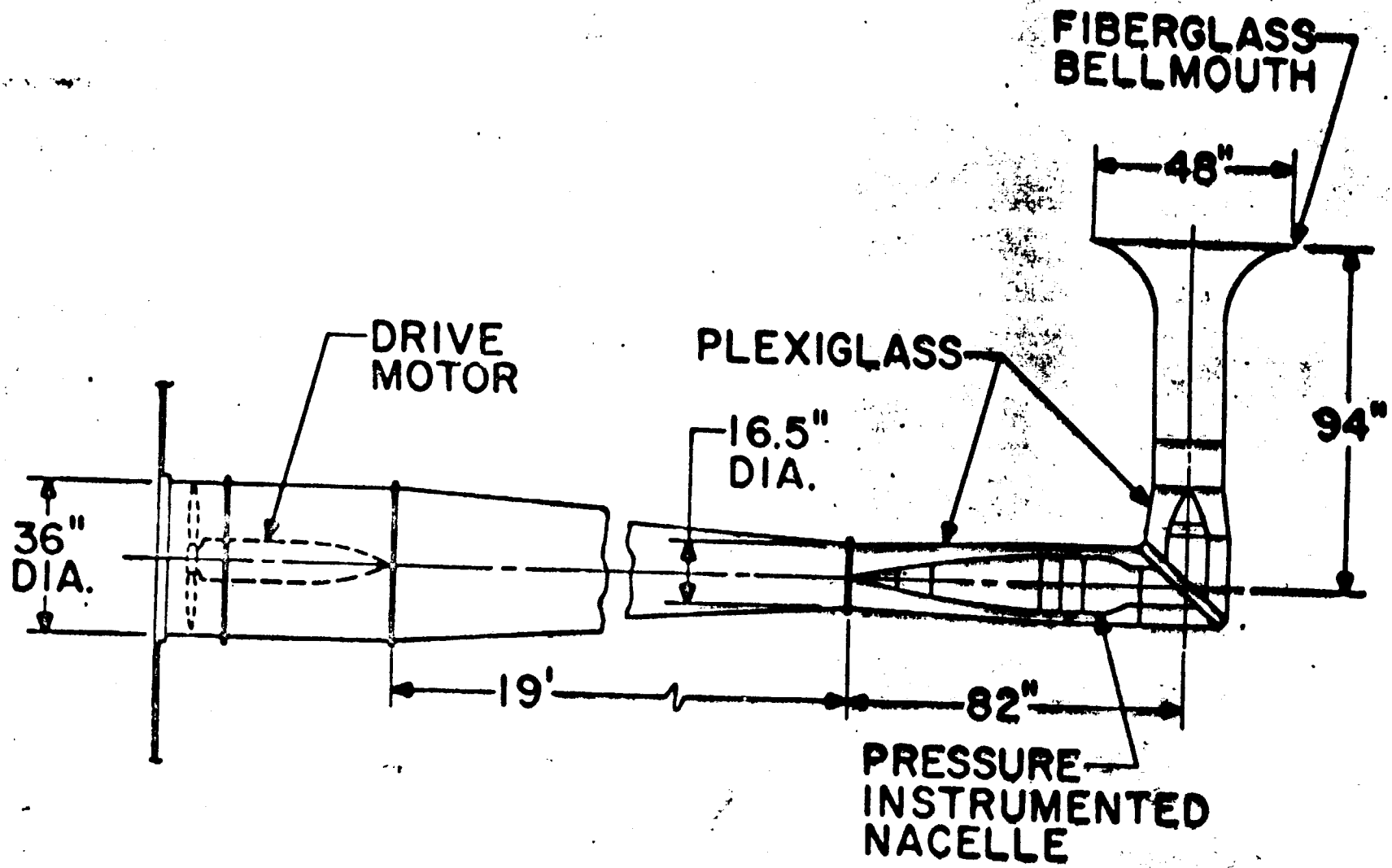

ORIGINAL PAGE IS
OF POOR QUALITY

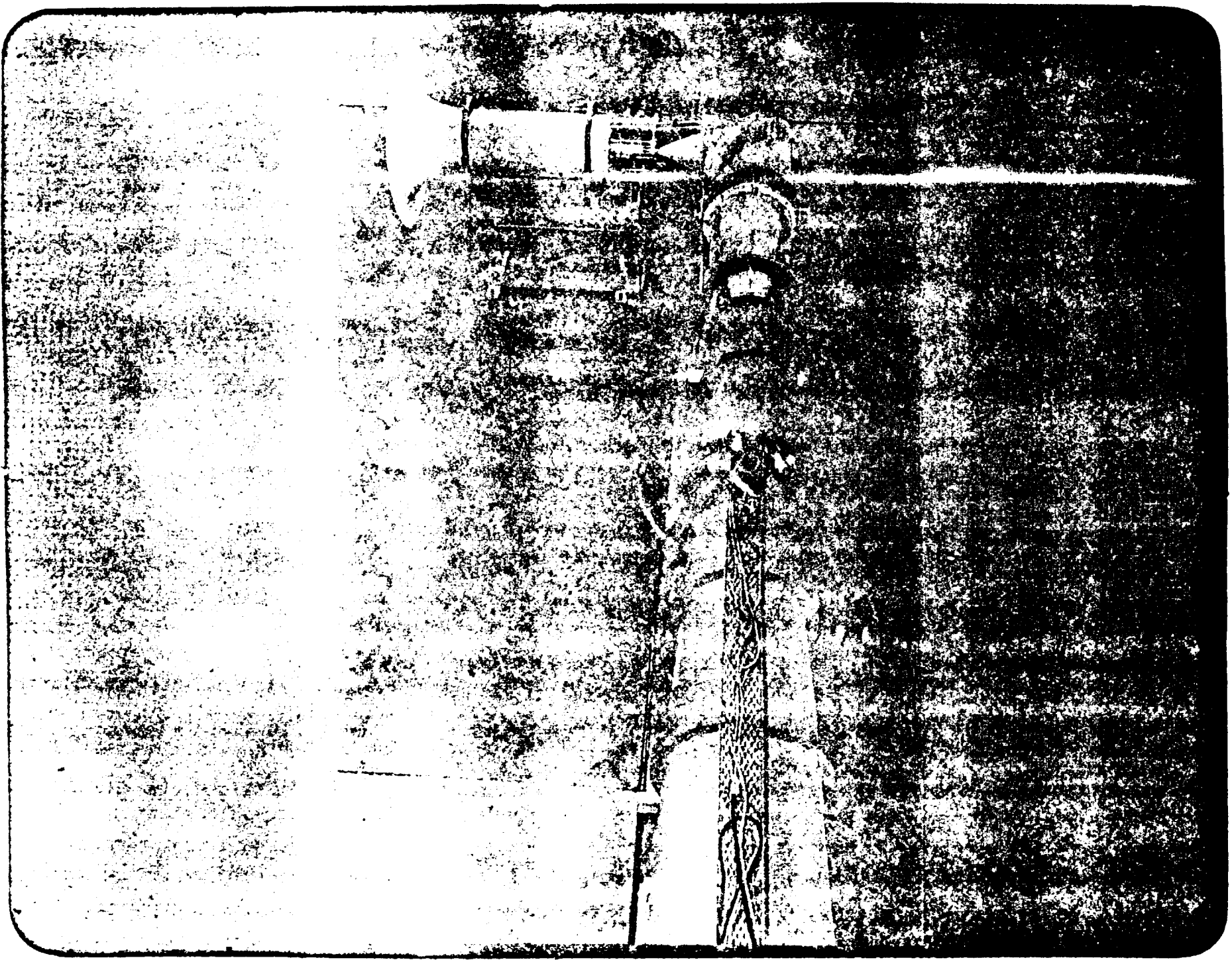

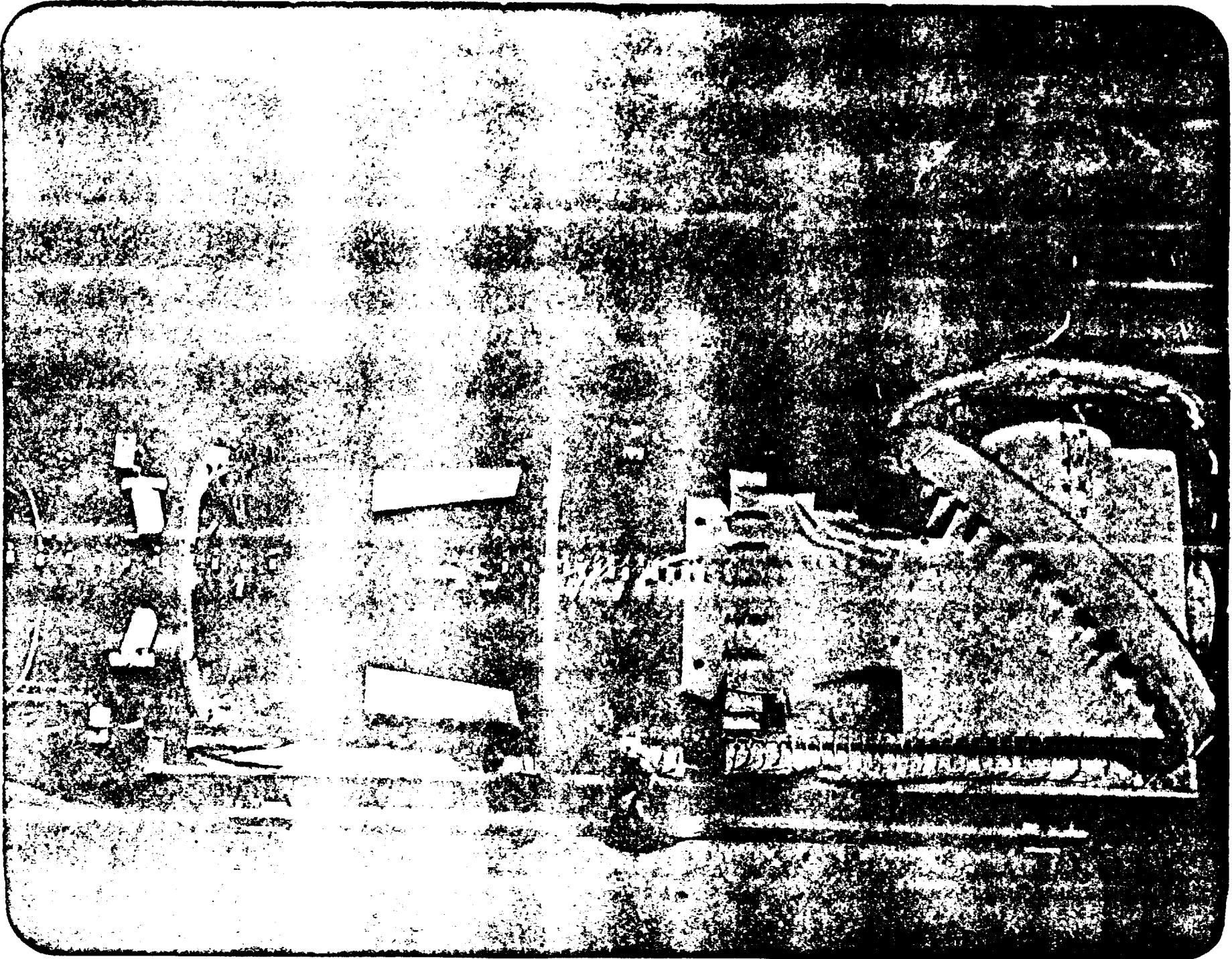

ORIGINAL PAGE IS
OF POOR QUALITY

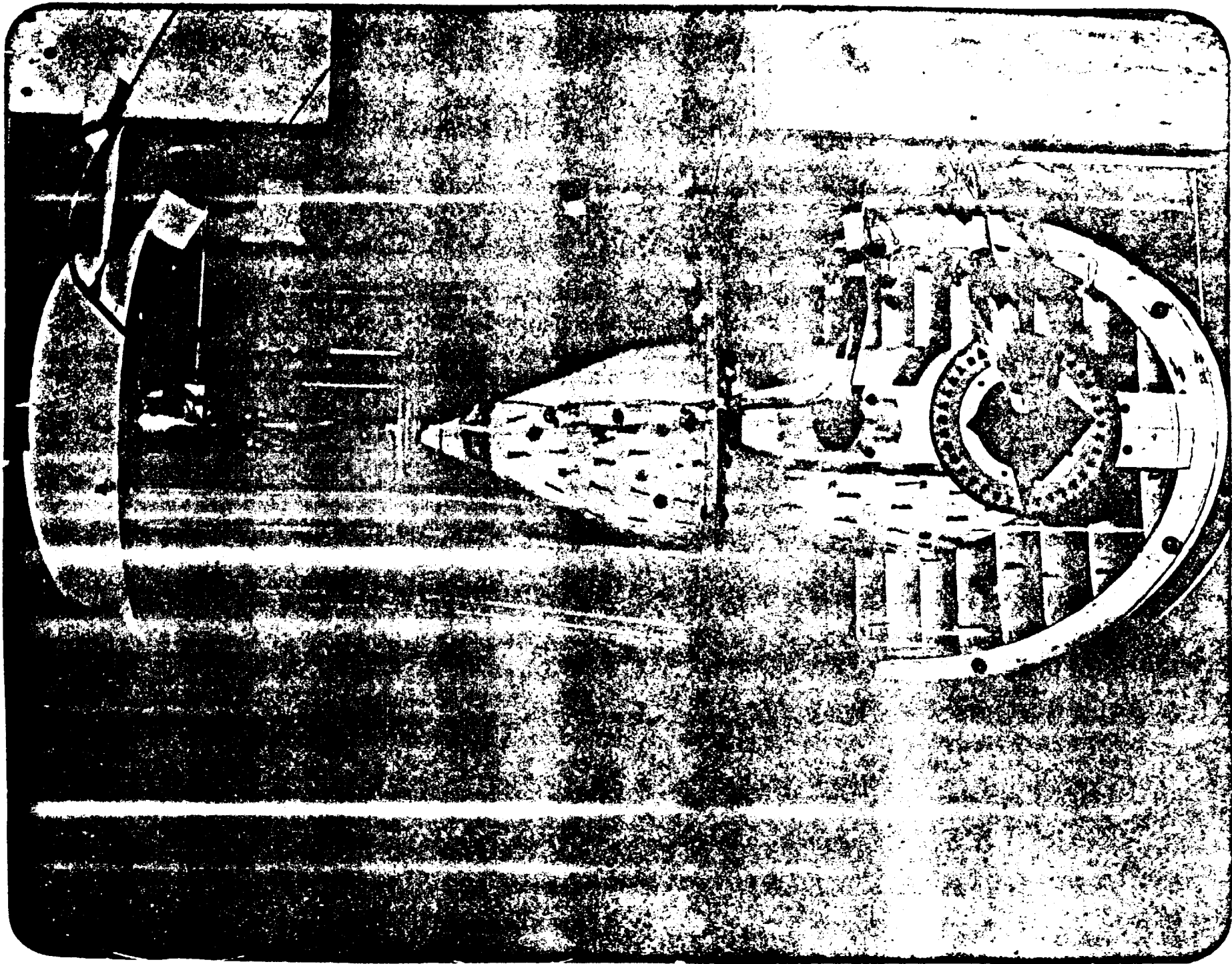

ORIGINAL PAGE IS
OF POOR QUALITY

NTF FAN ANNULUS TOTAL PRESSURE DISTORTION

$$\Delta P_T = (P_{T,MAX} - P_{T,MIN})_{FAN}$$

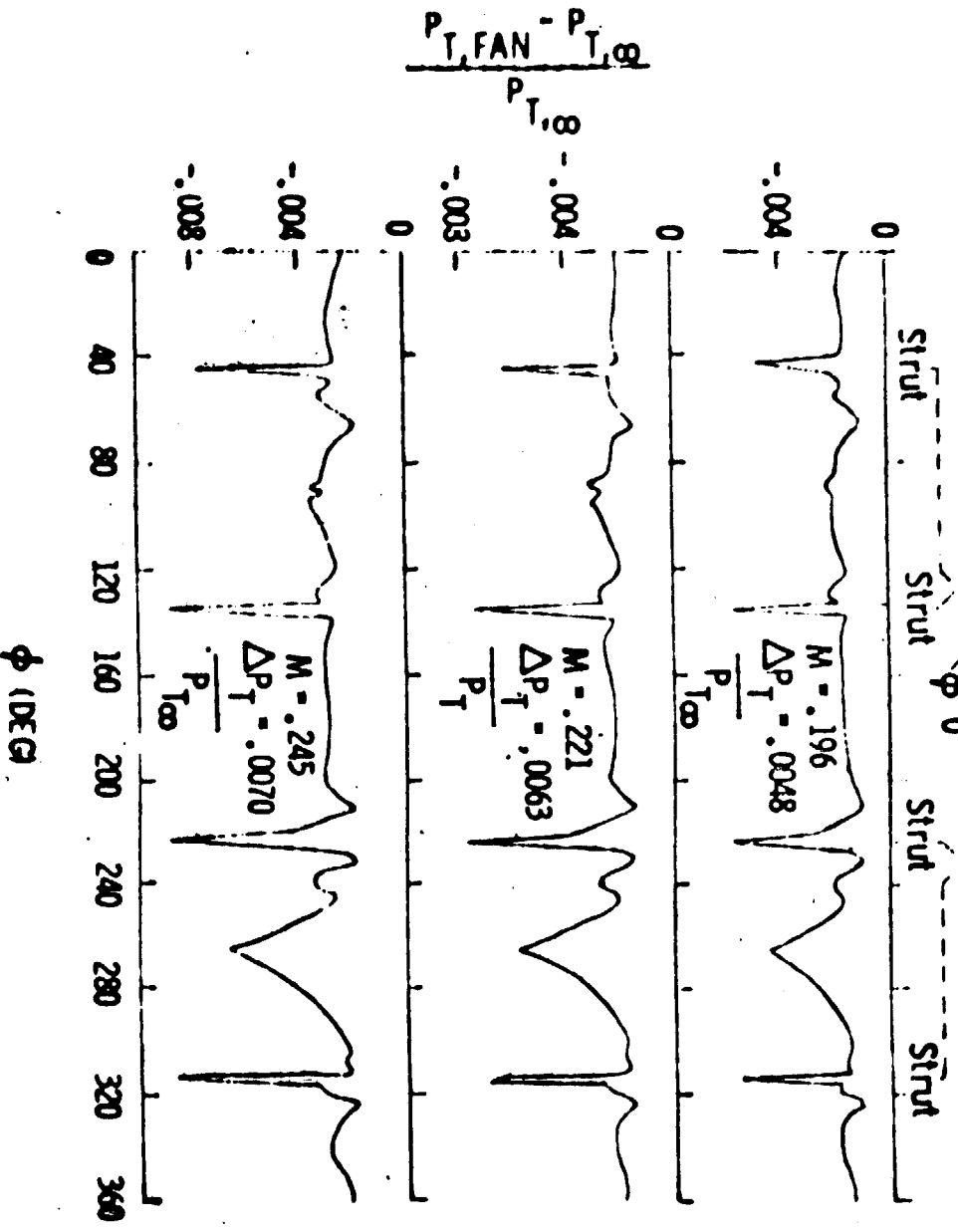
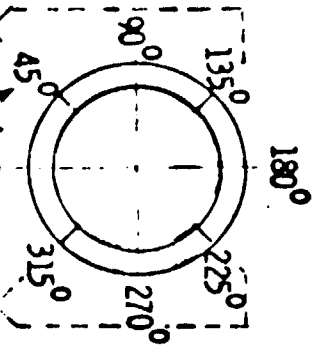

NATIONAL TRANSONIC FACILITY FAN SECTION ASSEMBLY

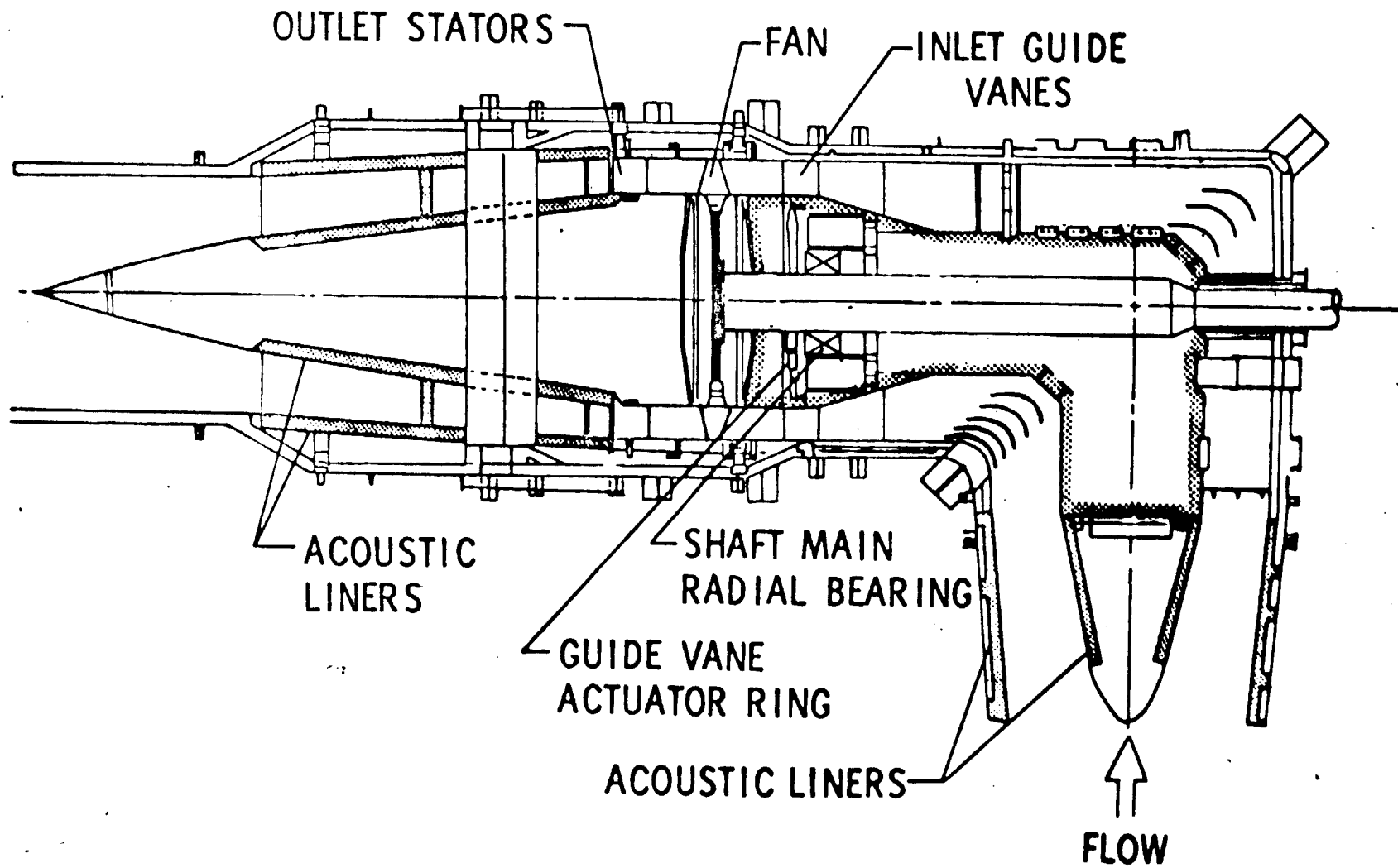

UNIT 1

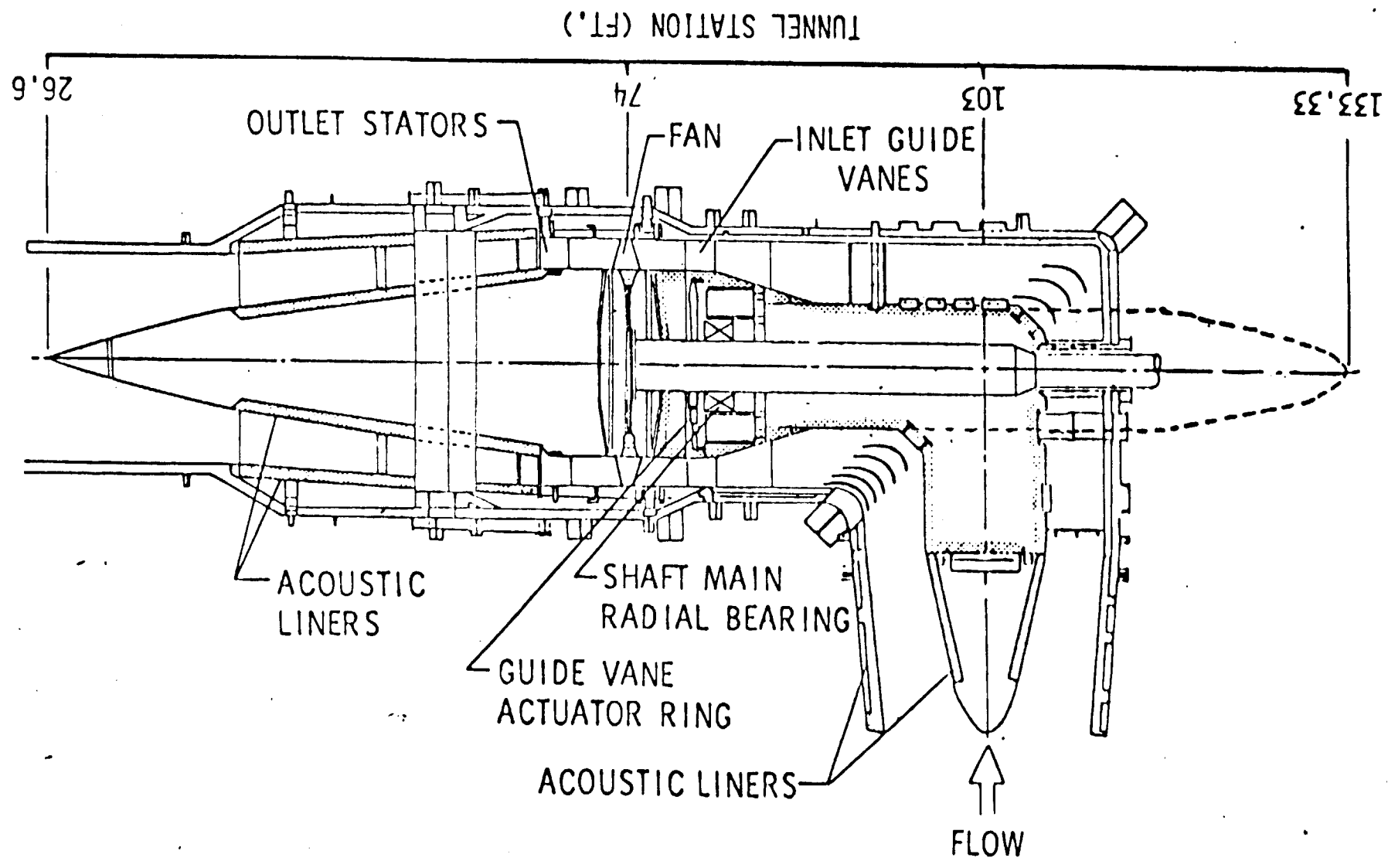

NTF FAN NACELLE

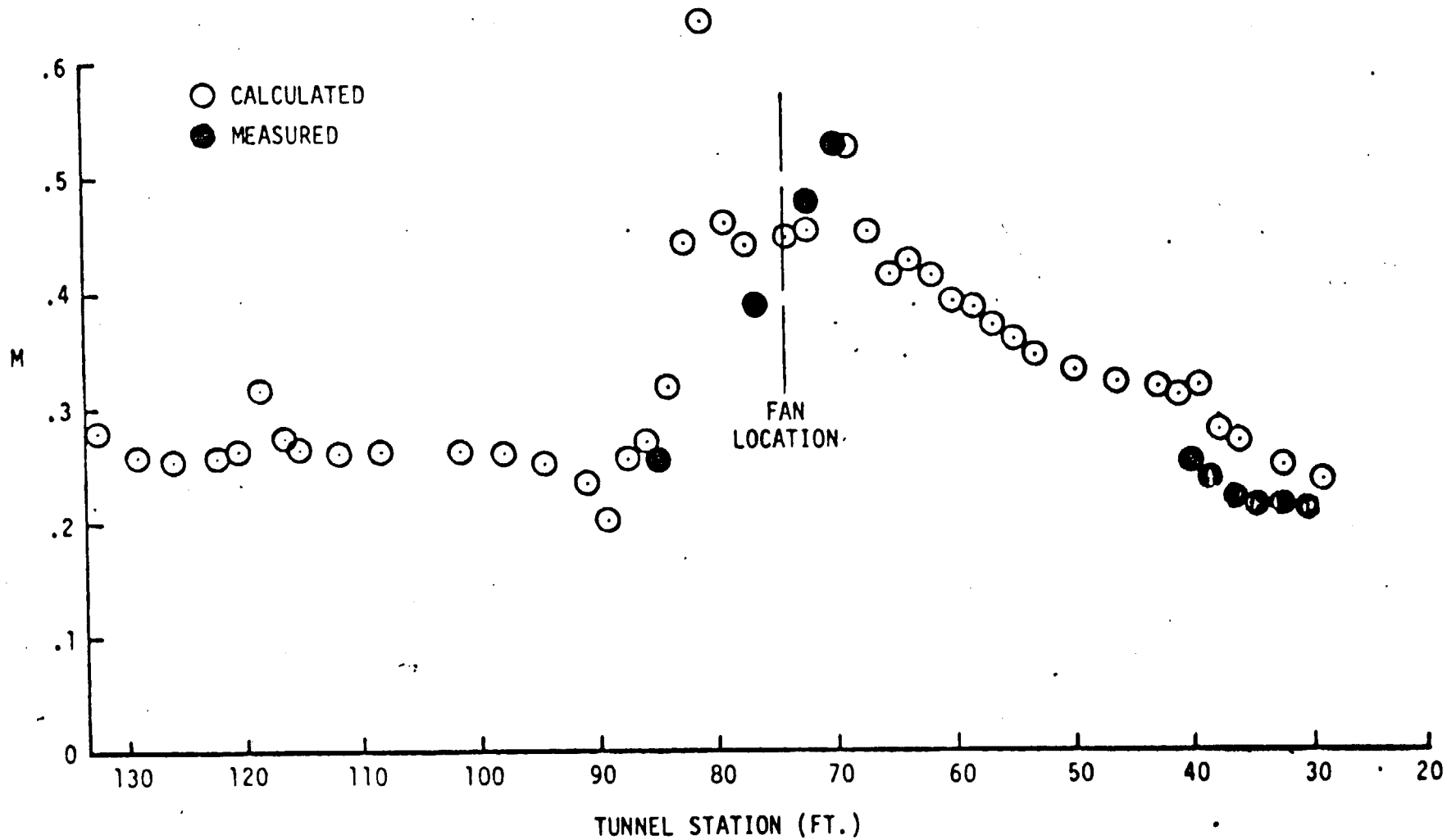

FAN - GUIDE VANE PERFORMANCE MAP

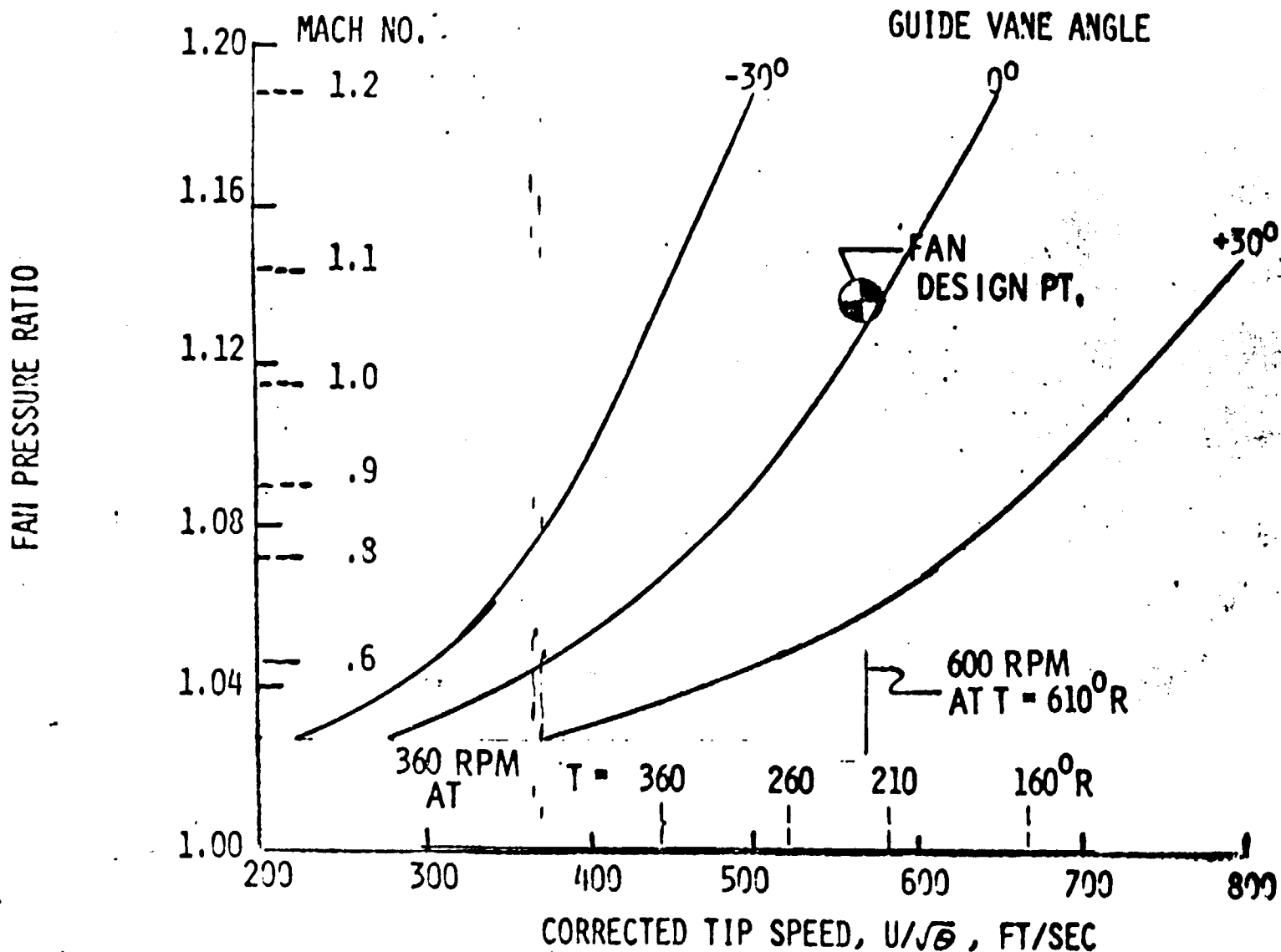

OFF-DESIGN PERFORMANCE VERIFICATION

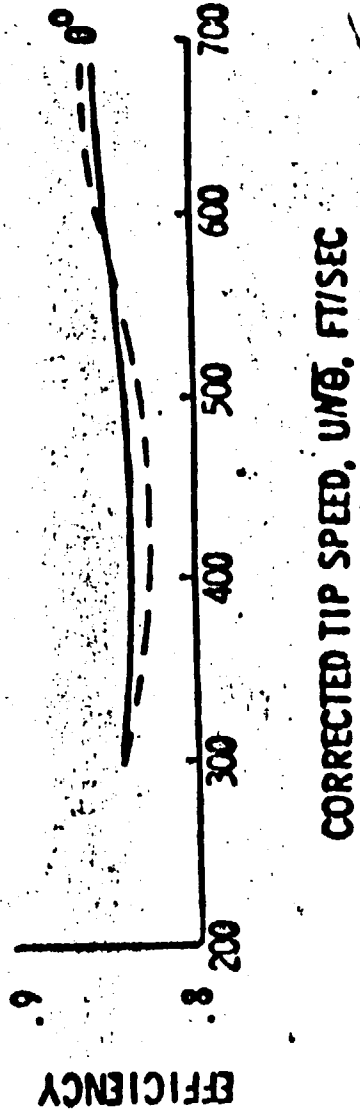
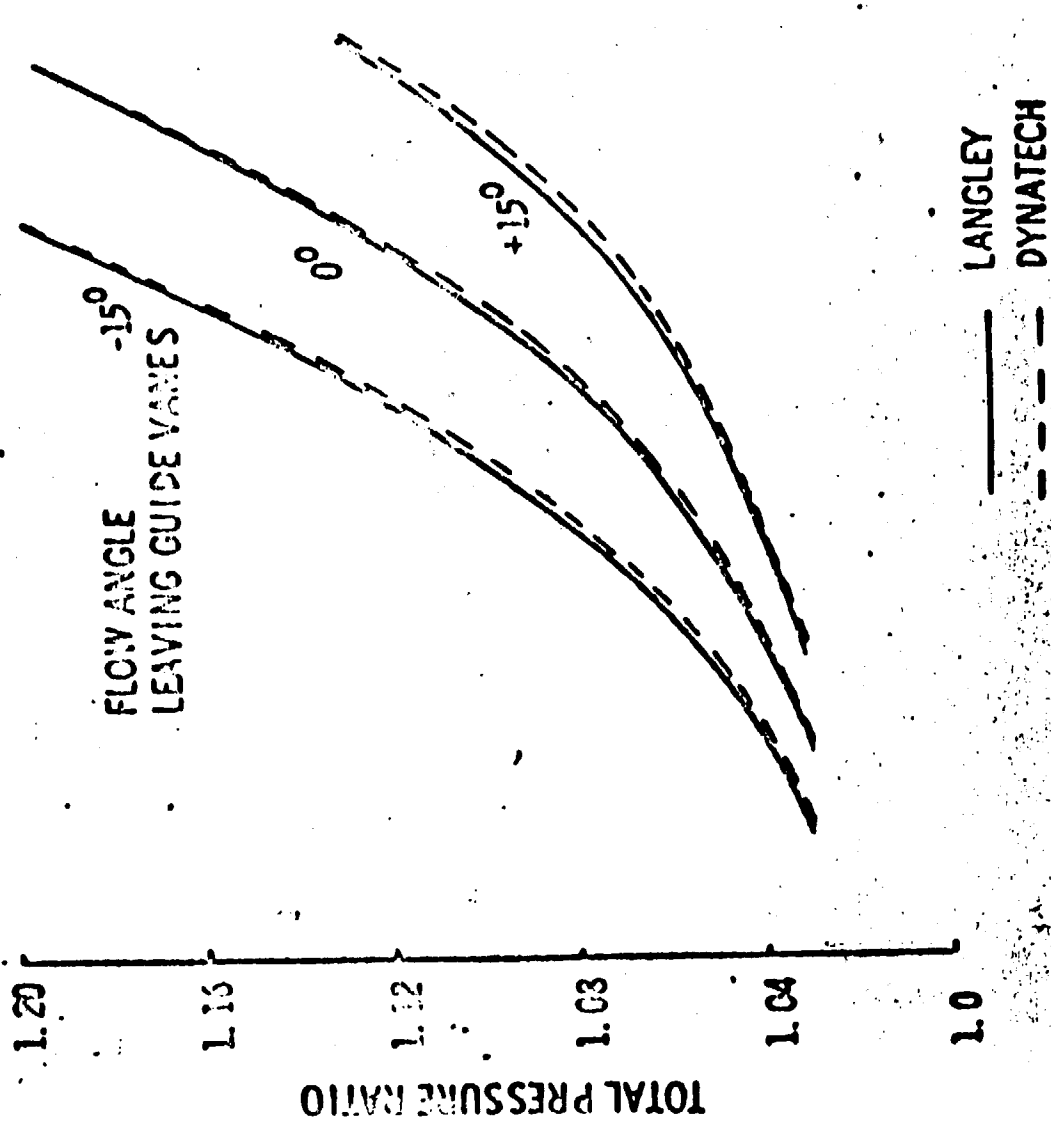

DESIGN CONDITION

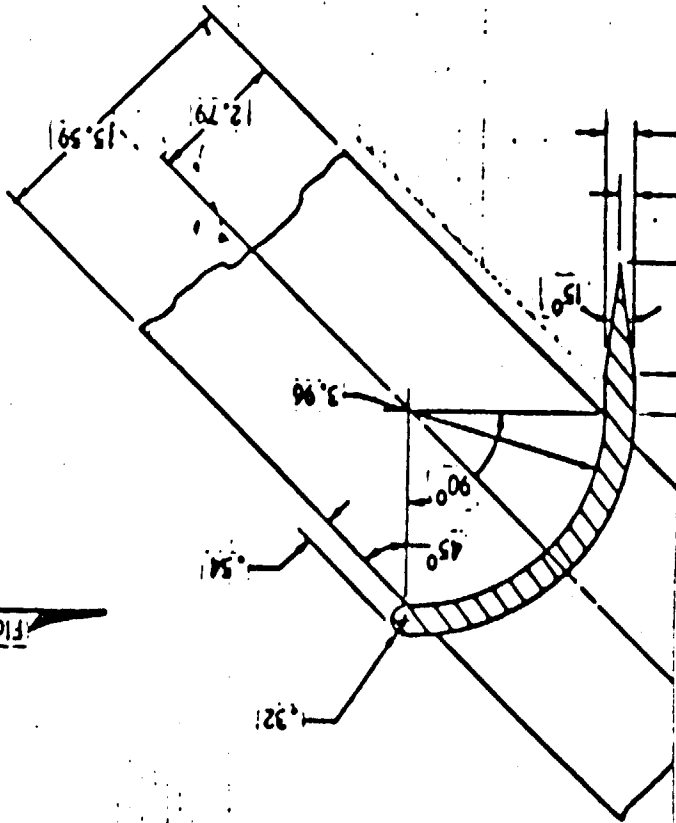

Vane number	Spacing	Vane number	Spacing
1	1.14	9	21.21
2	2.77	10	24.89
3	4.62	11	28.80
4	6.73	12	32.99
5	9.12	13	37.44
6	11.76	14	42.14
7	14.66	15	47.09
8	17.81	16	52.32

Vane spacing given to inside surface of vane on centerline.

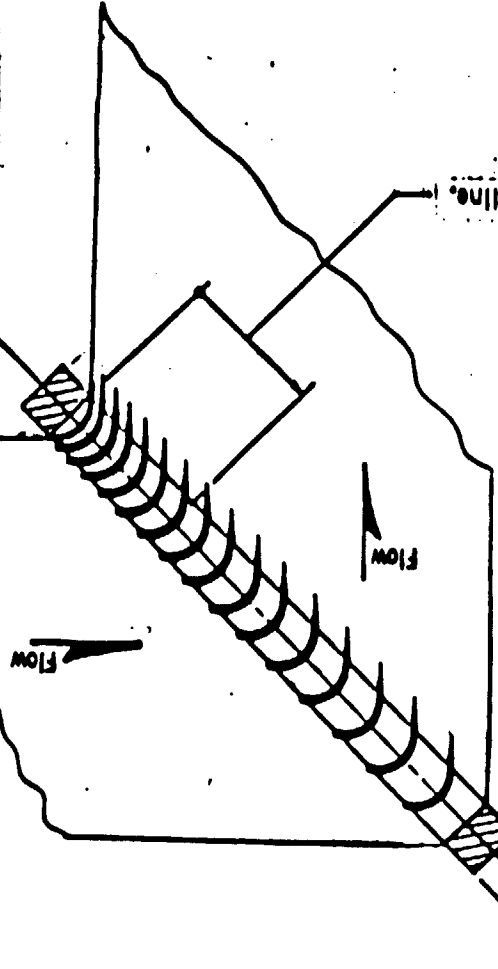

ORIGINAL PAGE IS
OF POOR QUALITY

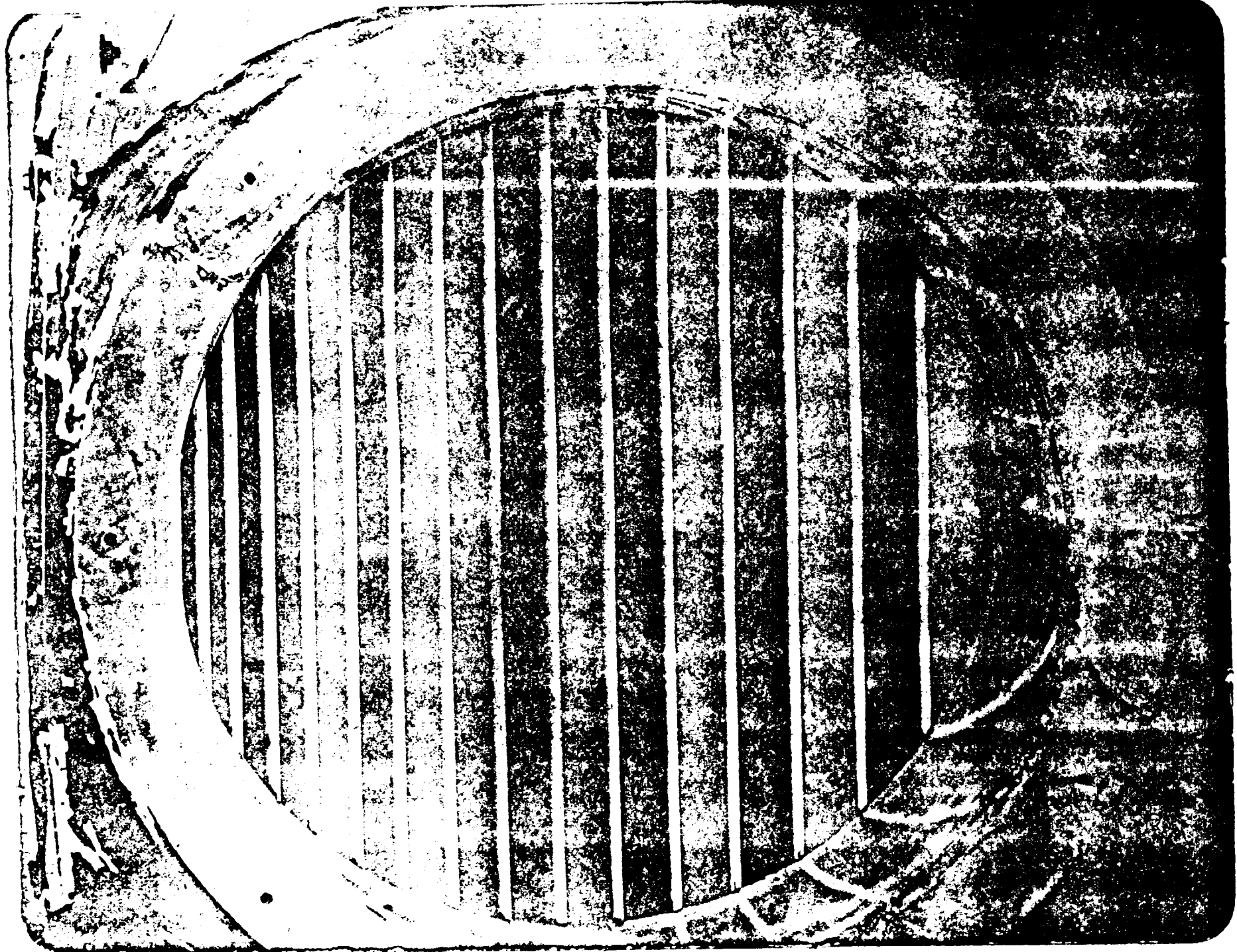

NASA LANGLEY RESEARCH CENTER

112

ORIGINAL PAGE IS
OF POOR QUALITY

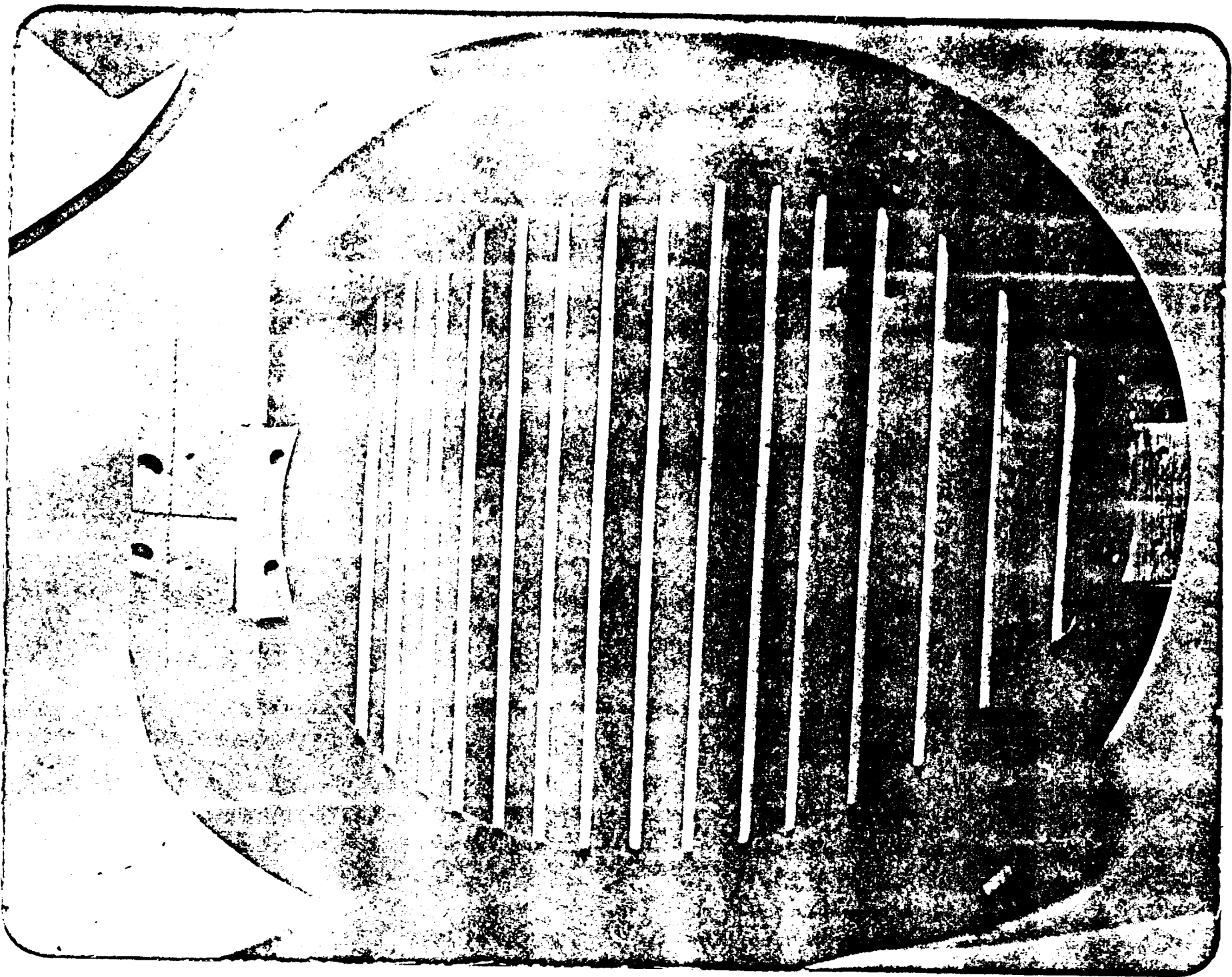

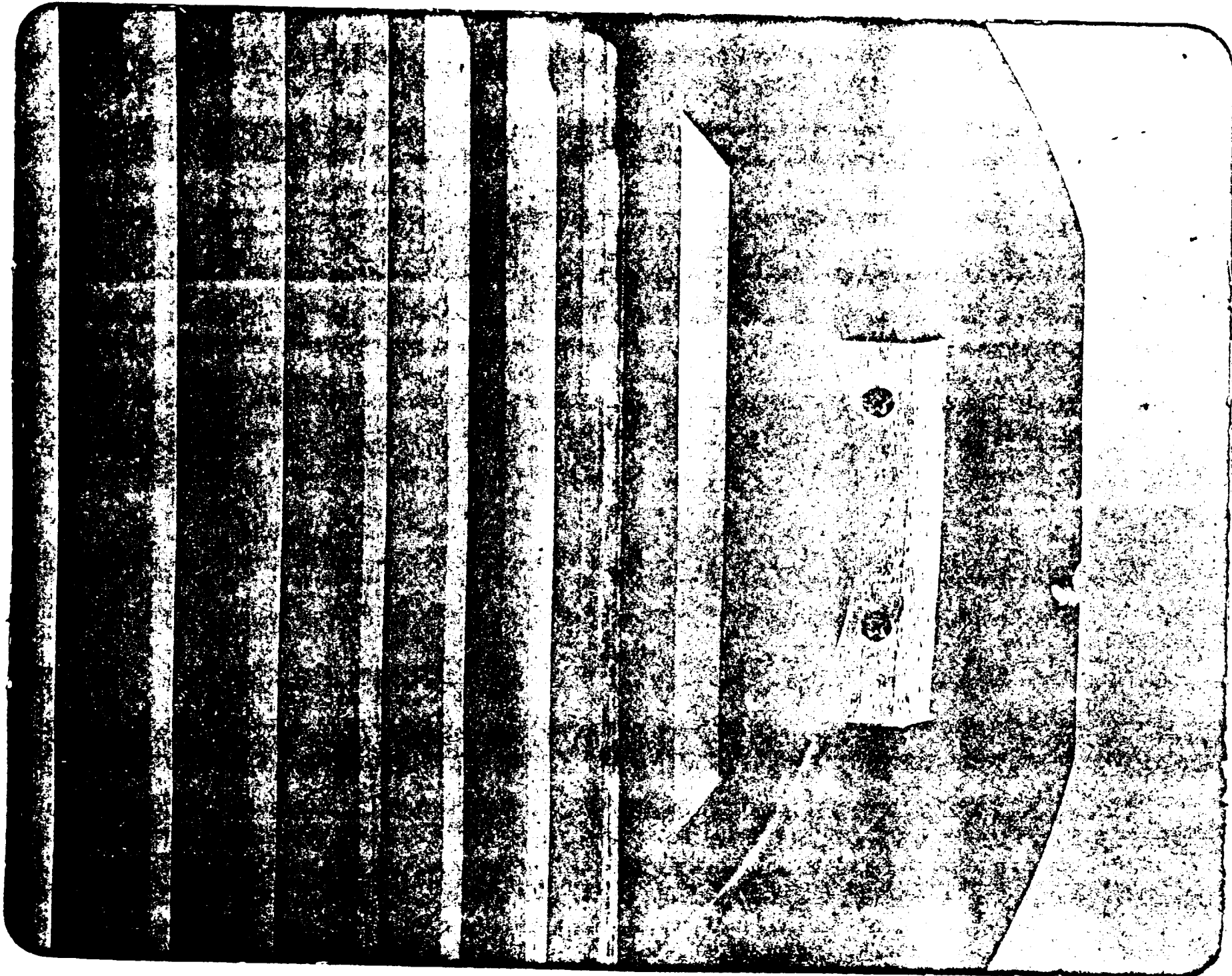

ORIGINAL PAGE IS
OF POOR QUALITY

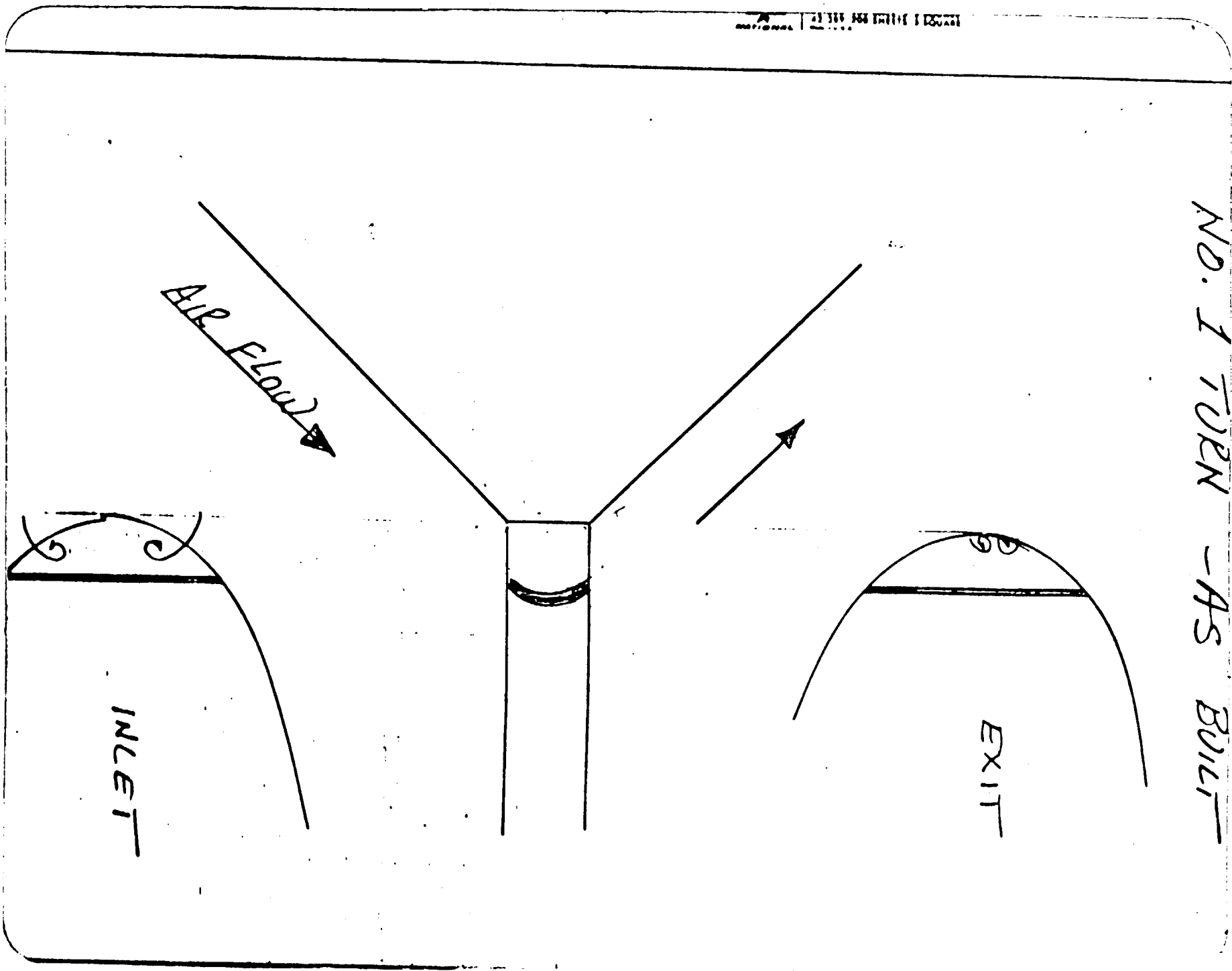

NO. 1 TURN - AS BUILT

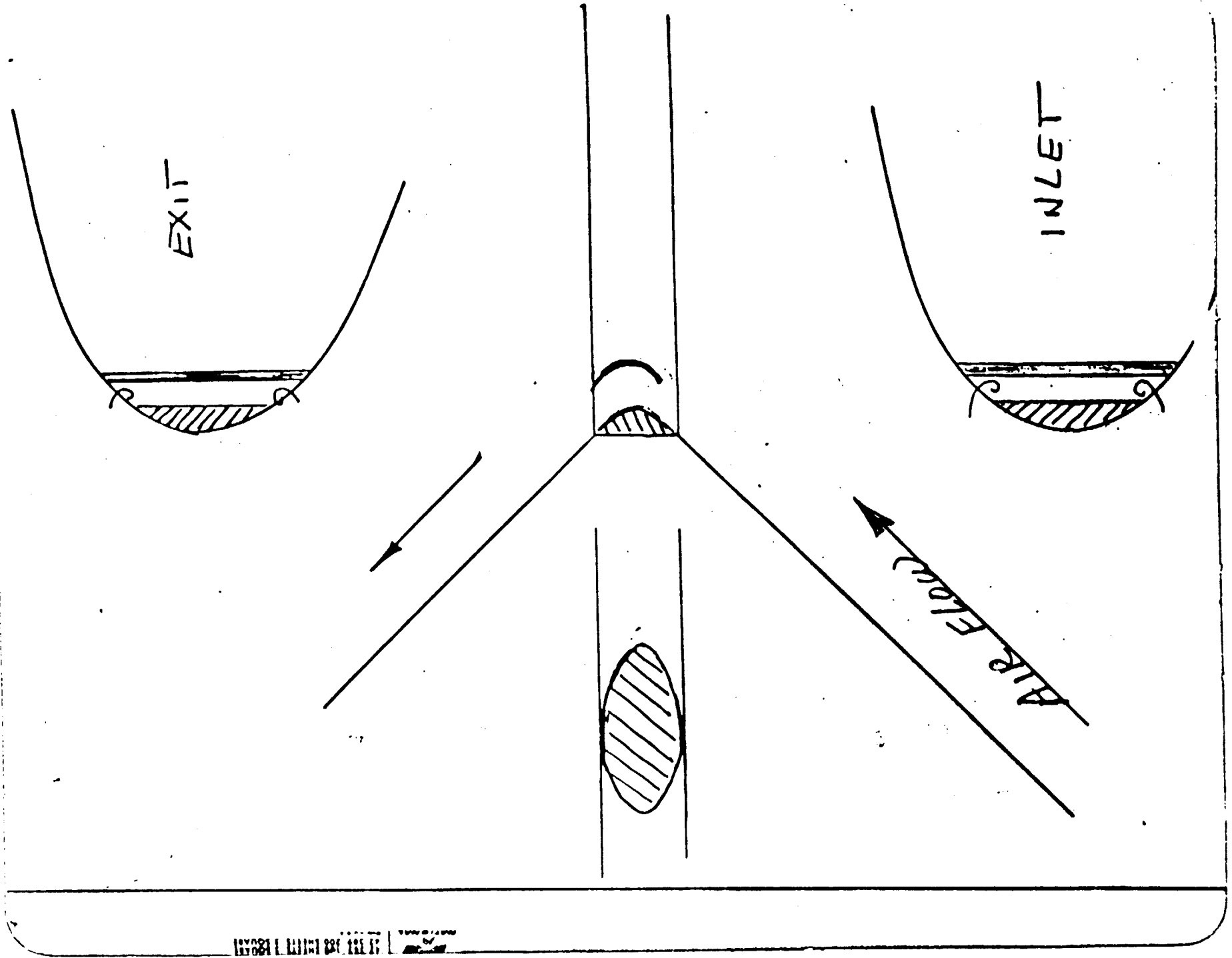

WITH SIMPLE CORNER FAIRING

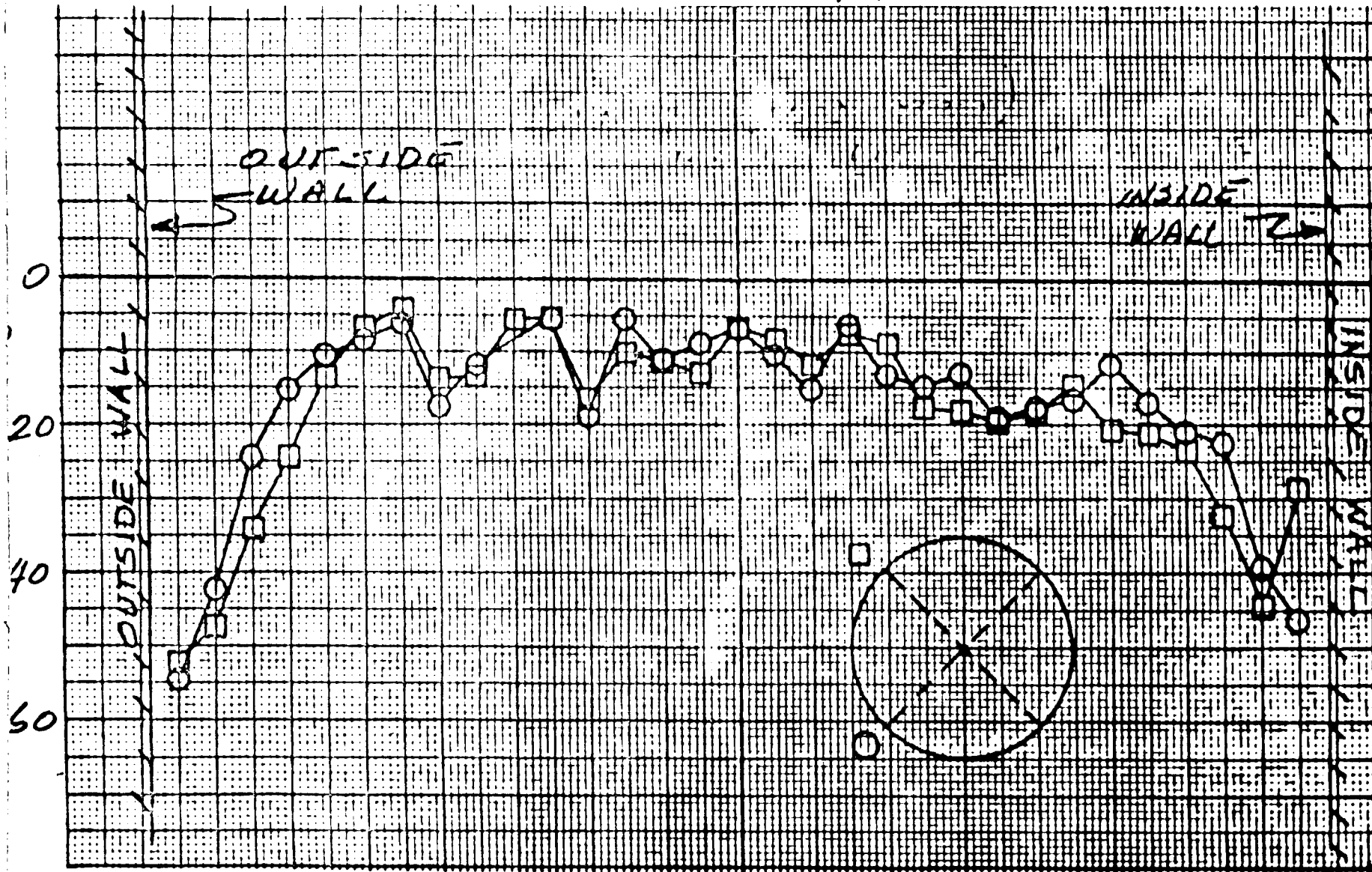

INLET DISTRIBUTION

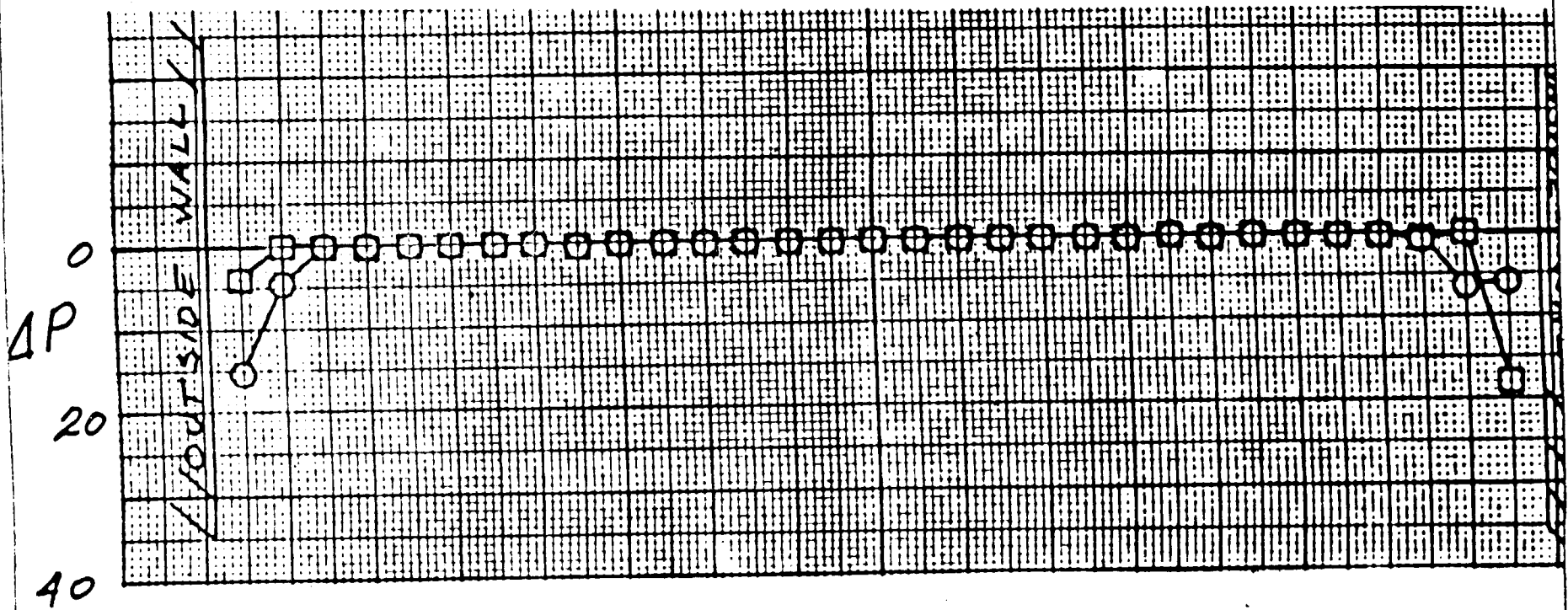

INTEGRATED LOSS COEFFICIENT

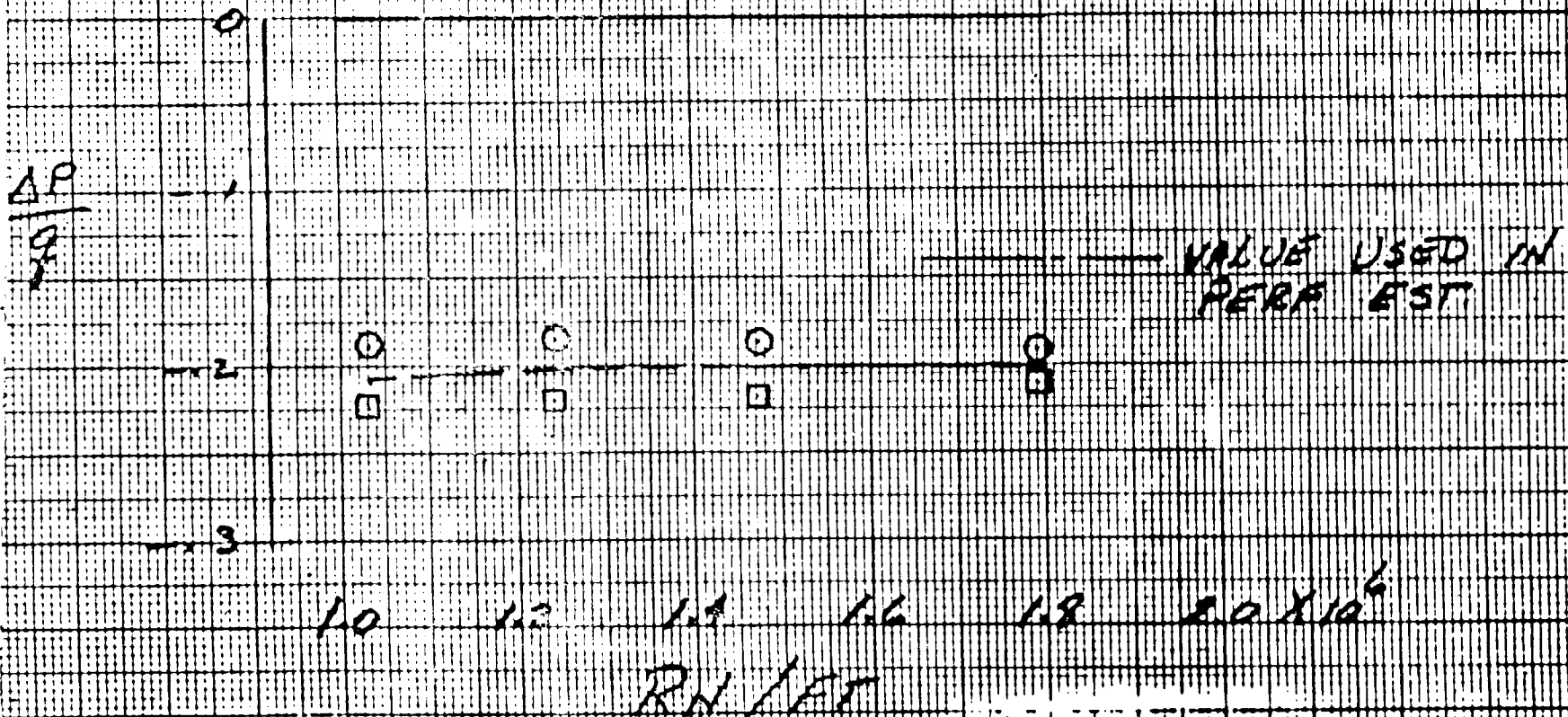

8'TPT HONEYCOMB AND SCREEN DEVELOPMENT

