

1991 NASA/ASEE SUMMER FACULTY FELLOWSHIP PROGRAM

**JOHN F. KENNEDY SPACE CENTER
UNIVERSITY OF CENTRAL FLORIDA**

REFLECTION EFFECTS IN MULTIMODE FIBER SYSTEMS UTILIZING LASER TRANSMITTERS

PREPARED BY:	Harry E. Bates
ACADEMIC RANK:	Professor
UNIVERSITY AND DEPARTMENT:	Towson State University Department of Physics
NASA/KSC	
DIVISION:	Electronic Systems
BRANCH:	Communications
NASA COLLEAGUE:	Po T. Huang
DATE:	August 20, 1991
CONTRACT NUMBER:	University of Central Florida NASA-NGT-60002 Supplement: 6

ACKNOWLEDGEMENTS

This research effort would not have been possible without the assistance, cooperation and careful planning of a number of people. Larry Hand and Po Huang suggested the program and provided valuable support along the way. Po Huang was always available to answer questions provide literature references. He also gave guidance and support in more ways than can be described here. All levels of Engineering management above Po and Larry beginning with Perry Rogers provided valuable assistance and showed genuine interest in the project. Everyone was willing to listen and suggest solutions to problems. Special thanks to Fred MacKenzie, Richard Hall and Otto Variossi for helping to provide computers and software to use at Headquarters Building and introductions to people who could help with other problems in the area of data analysis. Mark Nurge was also especially helpful in assisting with ideas and equipment needed to interface the Macintosh in the laboratory to the optical spectrum analyzer. Boeing personnel were also most helpful in the laboratory. Special thanks to Houston Galloway and Bob Swindel who worked closely in all phases of this project including, but not limited to, design and acquisition of necessary equipment, shop work, and data collection. Brent Yates a coop from Georgia Tech. provided excellent assistance in the laboratory and with computer work especially in creating a model of a low pass filter to use in testing the RF spectrum analyzer and in transferring data files to the VAX. Thanks to Dr. Bob Youngquest who was willing to provide optical parts, filters and most of all ideas and approaches to technical problems.

ABSTRACT

A number of optical communication lines are now in use at the Kennedy Space Center (KSC) for the transmission of voice, computer data and video signals. At the present time all of these channels utilize a single carrier wavelengths centered near 1300 nm or 1550 nm. Engineering tests in the past have given indications of the growth of systematic and random noise in the RF spectrum of a fiber network as the number of connector pairs is increased. This noise seems to occur when a laser transmitter is utilized instead of a LED. It has been suggested that the noise is caused by back reflections created at connector fiber interfaces. Experiments were performed to explore the effect of reflection on the transmitting laser under conditions of reflective feedback.. This effort included, computer integration of some of the instrumentation in the fiber optic laboratory utilizing the Lab View software recently acquired by the laboratory group. The main goal was to interface the Anritsu Optical and RF spectrum analyzers to the Macintosh II computer so that laser spectra and network RF spectra could be simultaneously and rapidly acquired in a form convenient for analysis. Both single and multimode fiber is installed at the Space Center. Since the great majority is multimode, this effort concentrated on multimode systems.

SUMMARY

A number of optical communication lines are now in use at the Kennedy Space Center (KSC) for the transmission of voice, computer data and video signals. At the present time all of these channels utilize a single carrier wavelengths centered near 1300 nm or 1550 nm. Engineering tests in the past have given indications of the growth of systematic and random noise in the RF spectrum of a fiber network as the number of connector pairs is increased. This noise seems to occur when a laser transmitter is utilized instead of a LED.

It has been suggested that the noise is caused by back reflections created at connector fiber interfaces. Experiments were performed to explore the effect of reflection on the transmitting laser under conditions of reflective feedback and on the modulation transmitted by the fiber optic link.

A major part of this effort included, computer integration of some of the instrumentation in the fiber optic laboratory utilizing the Lab View software recently acquired by the laboratory group. The main goal was to interface the Anritsu Optical and RF spectrum analyzers to the Macintosh IIX computer so that laser spectra and network RF spectra could be simultaneously and rapidly acquired in a form convenient for analysis. This goal was achieved. So much data was accumulated during these experiments that additional work will be required to do a complete detailed statistical analysis. At this point, only preliminary qualitative observations can be made through the use of 3D surface plots of data.

It was confirmed that connector reflections cause the RF spectrum to become perturbed. The more connectors in a network, the greater the perturbation. The optical spectrum also seems to be perturbed but this effect is not as easy to correlate to the connector number based on a quick look at the data. A more detailed analysis is required.

Some surprising results were also obtained. These include a chirp in the transmitter laser spectrum observed by utilizing a high speed spectral technique involving the use of a Fabry Perot interferometer. The success of this experiment suggests an experimental setup utilizing a boxcar signal averager for future work.

It was found that low frequency large amplitude motions and vibrations could adversely affect the optical spectrum and the RF spectrum. These results have significant implications when considering the design of any fiber optic system where fiber is likely to be subjected to such mechanical perturbations. For example in applications where a fiber data transmission link is located in a joint that can move while data is transmitted. Also in the case of large amplitude vibrations that might be encountered in the area of a launch beyond T + 0.

Both single and multimode fiber is installed at the Space Center. Since the great majority is multimode, this effort concentrated on multimode systems.

TABLE OF CONTENTS

LIST OF ILLUSTRATIONS

ABBREVIATIONS AND ACRONYMS LIST

- I. INTRODUCTION
- II. INTEGRATED LABORATORY SPECTRAL ANALYSIS SYSTEM
- III. EXPERIMENTS PERFORMED
- IV. CONCLUSIONS
- Appendix A. SELECTED DATA OUTPUT FROM TMODE EXPERIMENTS
- Appendix B. SELECTED DATA OUTPUT FROM RMODE EXPERIMENTS
- Appendix C. HIGH SPEED VARIATIONS IN CARRIER OBSERVED USING FABRY PEROT INTERFEROMETER
- Appendix D. OTDR OBSERVATIONS OF LINKS USED IN TESTS

LIST OF ILLUSTRATIONS

- Figure 2.4-1. Concept Drawing Fiber to Free Space to Fiber system
(not to scale and fiber V block detail not shown here.)
- Figure 2.5-1. Concept Drawing Fabry Perot Interferometer system
(not to scale and fiber V block detail not shown here.)
- Figure 2.5-2. Block Diagram Illustrating Method of Utilizing Fabry Perot Interferometer to Collect Spectrum.
- Figure 2.5-3. Fabry Perot Transmission Wavelength vs. Applied Voltage
- Figure 3.1.1-1. Transmission Mode Experimental Setup.
- Figure 3.1.2-2. Reflection Mode Experimental Setup
- Figure 3.2-1. Free Space Test Link.
- Figure 3.2-2. The effects of elements in Free Space Link on RF Spectrum

ABBREVIATIONS AND ACRONYMS LIST

CDSC	Communications Distribution and Switching Center
OSA	Optical Spectrum Analyzer
OTDR	Optical Time Domain Reflectometer
LED	Light Emitting Diode
KSC	Kennedy Space Center
TX	Transmitter
RMODE	Reflection Mode
TMODE	Transmission Mode
RX	Receiver
LID	Laser Diode

I. INTRODUCTION

A number of optical communication links are now in use at the Kennedy Space Center (KSC) for the transmission of voice, computer data and video signals. At the present time all of these channels utilize a single carrier wavelengths centered near 1300 nm or 1550 nm. Engineering tests in the past have given indications of the growth of systematic and random noise in the RF spectrum of a fiber network as the number of connector pairs is increased. This noise seems to occur when a laser transmitter is utilized instead of a LED. It has been suggested that the noise is caused by back reflections created at connector fiber interfaces. These perturbations may have both systematic and non systematic components. Therefore, repetitive observations must be made. Computer controlled experiments were performed to explore the effect of reflection on the transmitting laser under conditions of reflective feedback. The first step in this effort was to interface the Anritsu Optical and RF spectrum analyzers to the Macintosh IIX computer so that laser spectra and network RF spectra could be simultaneously and rapidly acquired in a form convenient for analysis. Experiments were conducted using this setup as well as several others. The experimental configurations and computer integration system is first presented. A brief description of experimental conditions is given, results and conclusions summarized, and finally data in the form of graphs are given in Appendices.

II. INTEGRATED LABORATORY SPECTRAL ANALYSIS SYSTEM

2.1 OPTICAL SPECTRUM ANALYZER

An Anritsu optical spectrum analyzer was available in the laboratory to be used to perform spectral analysis of coherent and incoherent sources. This piece of test equipment was equipped with an IEEE 488 computer interface which provides for bidirectional computer communication. A portion of the work done under this research effort was to interface the OSA with a Macintosh IIX computer to enable the efficient collection of spectral data in machine readable form. It was envisioned that the operator would manually set up the spectrum analyzer for any given experiment and when a spectrum was collected, activate the computer interface system and acquire a sequential data file containing the maximum wavelength, the minimum wavelength of the scan and 501 data points of optical spectral power density expressed in dBm or mW evenly distributed over the spectral interval.

2.2 RF NETWORK/SPECTRUM ANALYZER

An Anritsu radio frequency spectrum/ network analyzer was available in the laboratory to be used to perform analysis of the information channel of fiber optic networks. By using a computer to serve as an integrated data collection system, the RF spectra generated by this analyzer could be collected almost simultaneously with the optical spectrum allowing a correlation of data between the two instruments. The laboratory's Macintosh computer allowed this integration to be accomplished.

2.3 COMPUTER ANALYSIS AND DATA COLLECTION

2.3.1 THE MACINTOSH IIX COMPUTER

The Macintosh IIX Computer utilized a IEEE-488 National Instruments GPIB interface board which permitted the Macintosh computer to be coupled with the optical spectrum analyzer and the RF spectrum/network analyzer. Labview software system was chosen as a medium in which to develop an application program to integrate the collection of data by these two instruments.

The program created to connect the Macintosh with the spectrum analyzers displays one window. The window contains two graphic elements that permit the real time observation of collected spectra while an experiment is in progress. Parameter inputs are available to provide for specifying the number of runs, the time in seconds between runs, the data storage disk name, the file name and experimental parameter notes to be saved in a text file. When the program is run, the optical spectrum analyzer and RF network/spectrum analyzers are triggered. The computer pauses to wait for data to be collected and spectra are displayed and written to two data files. The program assumes that experimental parameters are setup on the front panel of each instrument. Also, no error checking is performed on the data file name, volume name, or time between run parameters. Further work would need to be performed to make a more user friendly interface. Optical power vs wavelength and RF network transmission in dB vs frequency are stored on the designated disk for each data run made. The files are suitable for direct input to spread sheet and graphics programs. A series of VAX IMSL-based fortran programs have been written to assist in the analysis of multiple data runs. It was found that 15 seconds between runs and 40 total experimental runs would create a ten minute total test time and almost fill one double density (not high density) floppy disk with data. A total of 81 files are created, one not file and 20 files of optical and RF spectra.

2.3.2 VAX COMPUTER DATA ANALYSIS

The VAX support group created a set of graphics programs that could be used to display the data generated using the laboratory computer in a 3D spectrum/parameter axis plot. This set of programs can directly access the data files generated by the Labview application. In this stage of the analysis of the fiber optic systems, this 3D technique is used as the primary means of getting a first look at the data. Most of the conclusions drawn to date are based on this type of analysis. Further efforts will permit a more detailed statistical analysis to be performed. Some difficulty in preparing the plots resulted in no axis labels being printed in some cases. A summary of the experimental parameters for each run presented is given at the bottom of the plot. This should allow a reasonable interpretation of the results.

2.4 DESIGN OF FIBER TO FREE SPACE TO FIBER SYSTEM

In order to provide a means of inserting optical components such as wave plates, polarizers and a Fabry Perot interferometer into the optical beam path of a communication system, a means of connecting fiber optics to free space optics was required. Such a system was constructed using fiber holders, SLS-2.0-0.25-1.3 GRIN lenses selected from a laboratory set, precision translation stages to hold optical fiber and lenses, and an optical table for the assembly of components. The optical design of one configuration of the system is shown in the diagram below.

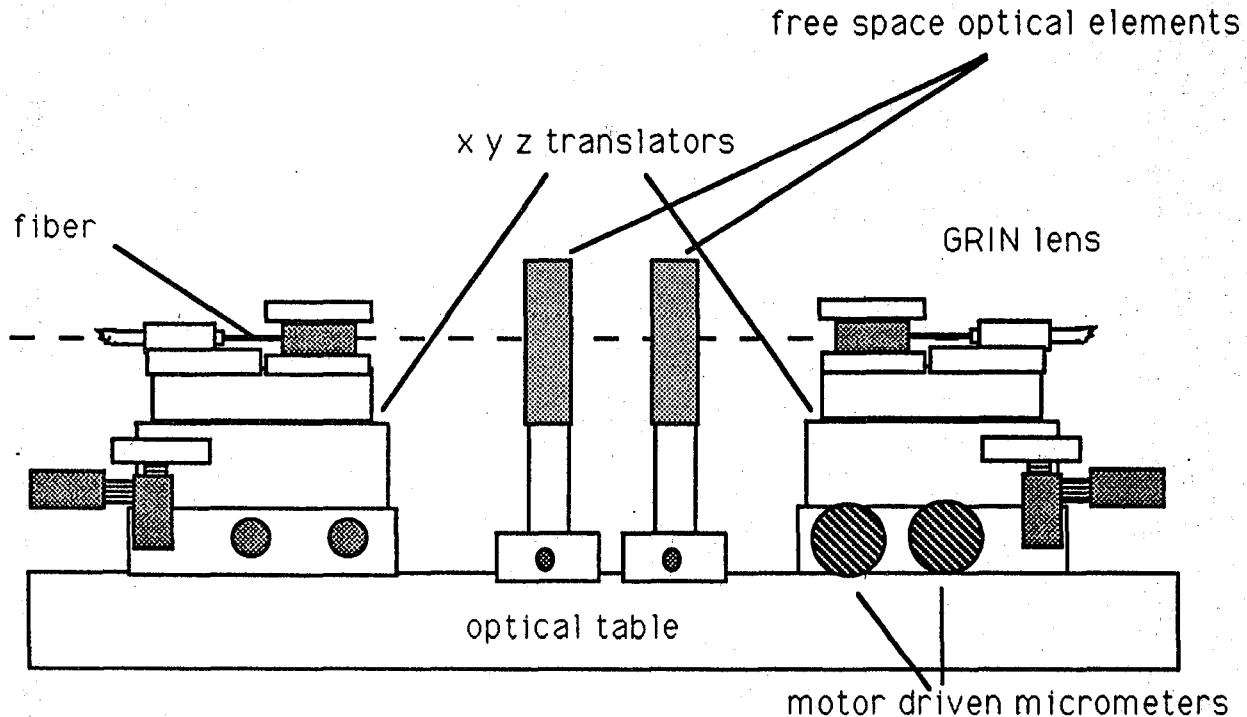

Figure 2.4-1. Concept Drawing Fiber to Free Space to Fiber system
(not to scale and fiber V block detail not shown here.)

Experiments were conducted to determine the attenuation of the system. It was found that with an air gap spacing of 6.5", sufficient to permit introduction of the Fabry Perot system. Under these conditions a 10 dB loss was sustained in going from fiber to air to fiber.

2.5 Fabry perot interferometer

A Fabry Perot interferometer was set up to be used to obtain high resolution spectra as well as allowing the study of transient spectral phenomena of the laser transmitters. This device consists of two high quality mirrors having very high reflectivity and held in stable mounting hardware that includes piezoelectric electromechanical translators. The mechanical system is shown in the figure below:

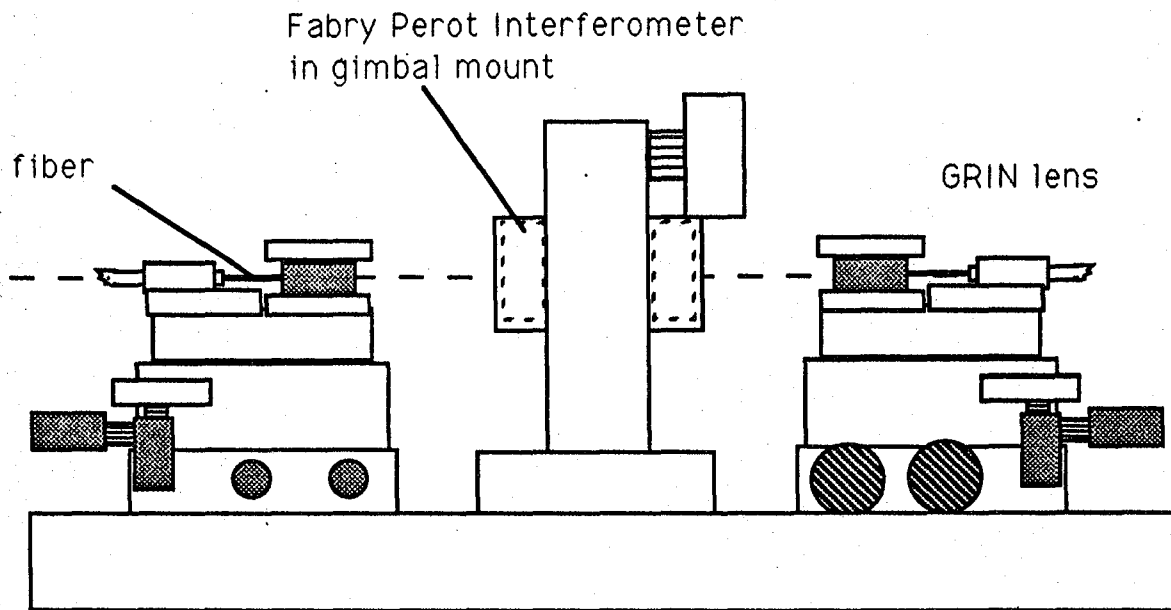

Figure 2.5-1. Concept Drawing Fabry Perot Interferometer system (not to scale and fiber V block detail not shown here.)

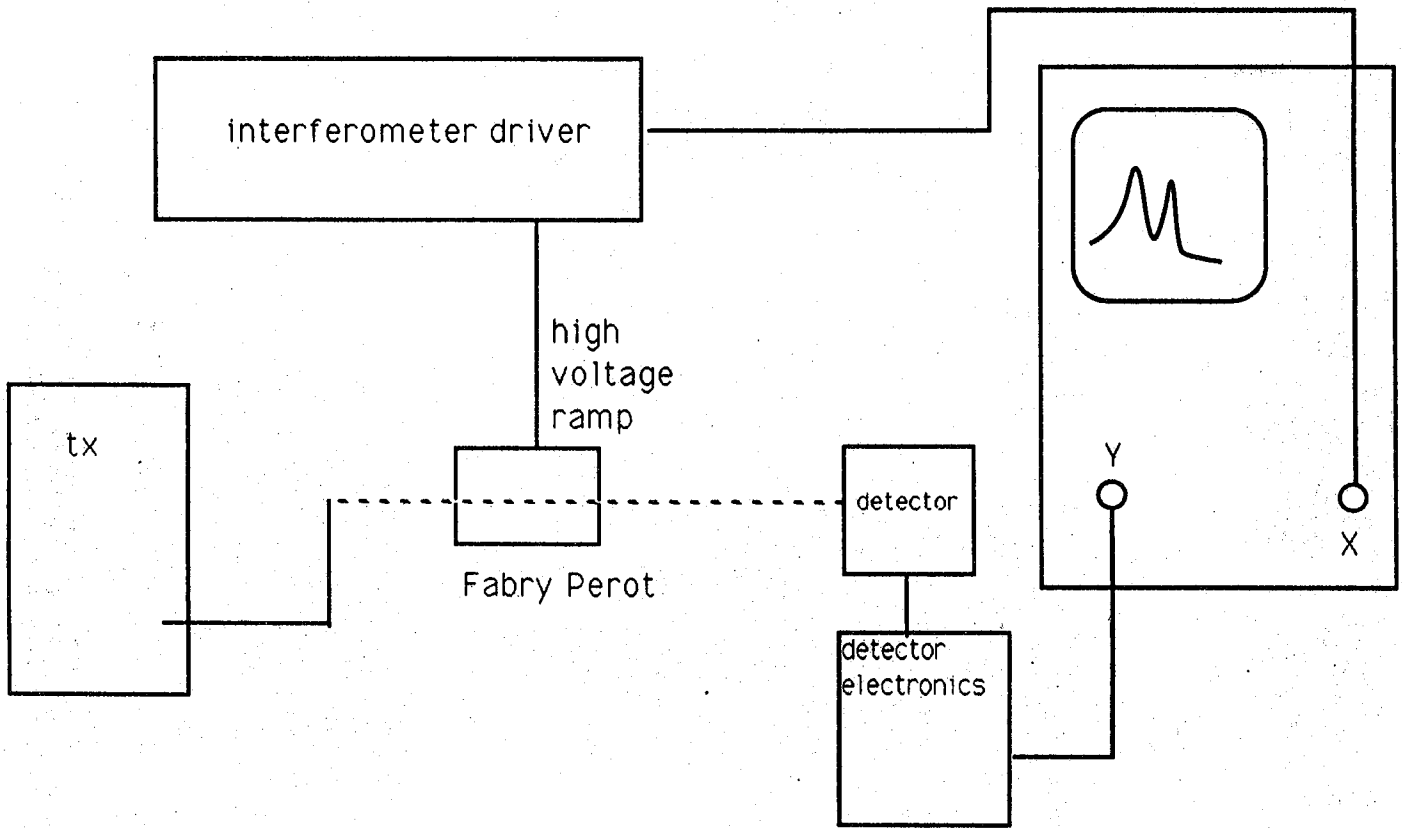

Figure 2.5-2. Block Diagram Illustrating Method of Utilizing Fabry Perot Interferometer to Collect Spectrum.

The Fabry Perot was calibrated by using the Anritsu optical spectrum analyzer as a standard. The results of this calibration are shown in the graph that follows.

Fabry Perot Interferometer Calibration

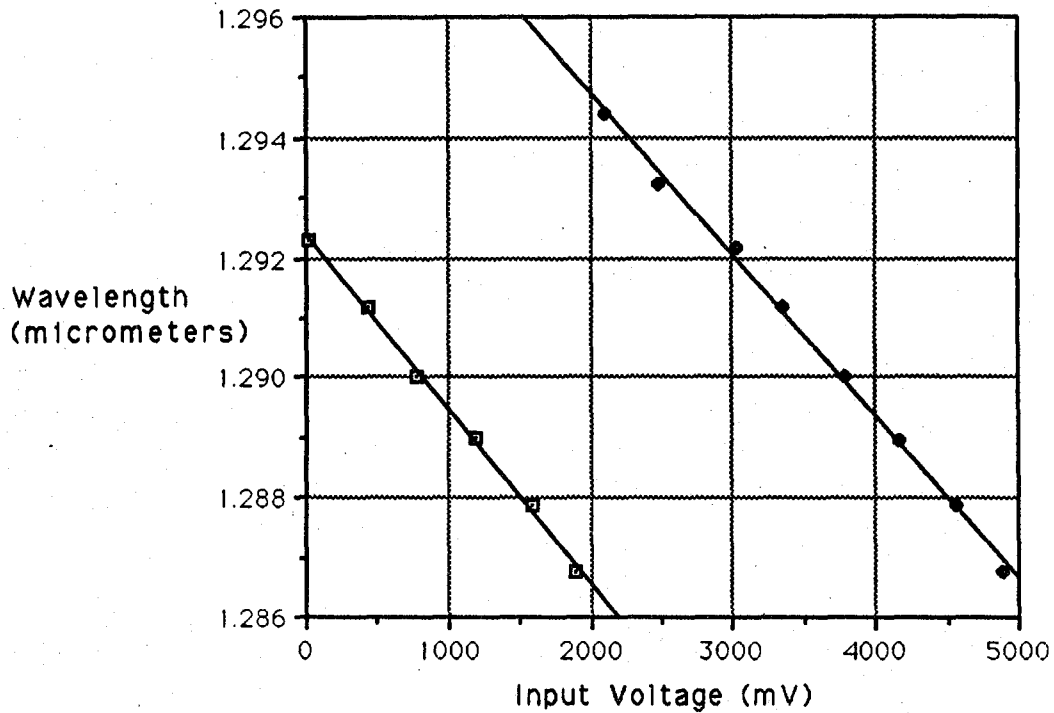

Figure 2.5-3. Fabry Perot Transmission Wavelength vs. Applied Voltage

A linear least squares fit to the above data in each of the two regions yielded the following equations:

$$L_a = 1.2924 - (2.92 \times 10^{-6}) v$$

$$L_b = 1.3001 - (2.70 \times 10^{-6}) v$$

Where the wavelength L for the two regions is given in micrometers and the voltage is given in mV.

The free spectral range can be obtained from the above by taking the difference between the y intercepts. This gives a measured free

spectral range of about 7.7 nm. Close to that calculated from the manufactures specifications of 8 nm.

The finesse of the system can be roughly estimated by observing that two adjacent modes can just be resolved. The laser modes are separated by 1.0 nm for the laser used in the tests. Thus the finesse is about $7.7\text{nm}/1.0\text{nm}$ or about 8. This is 1/5 that the expected value. This could be caused by modulation on the laser or poor alignment and filling of the aperture of the Fabry Perot. Additional time should be spent in resolving this issue.

Because of the limited time available to work with this instrument, the author was unable to use it to obtain high resolution spectra of the laser sources. However valuable experiments were undertaken to observe the temporal behavior of the transmitter sources at fixed wavelengths. The results of these experiments are discussed in a later section.

III EXPERIMENTS PERFORMED

3.1 BASIC NETWORK CONFIGURATIONS STUDIED

3.1.1 TRANSMISSION MODE

Transmission mode studies analyze the modulation and light spectra transmitted through the test loop. Experiments were conducted using a laboratory spool of test fiber, with various numbers of connector pairs on short jumpers added after the test spool and through one and two loop actual data links from the EDL to the CDSC. The experimental configuration is shown in the Fig. below. Each group of similar experiments included a base line configuration that only utilized the 1 km laboratory spool of fiber.

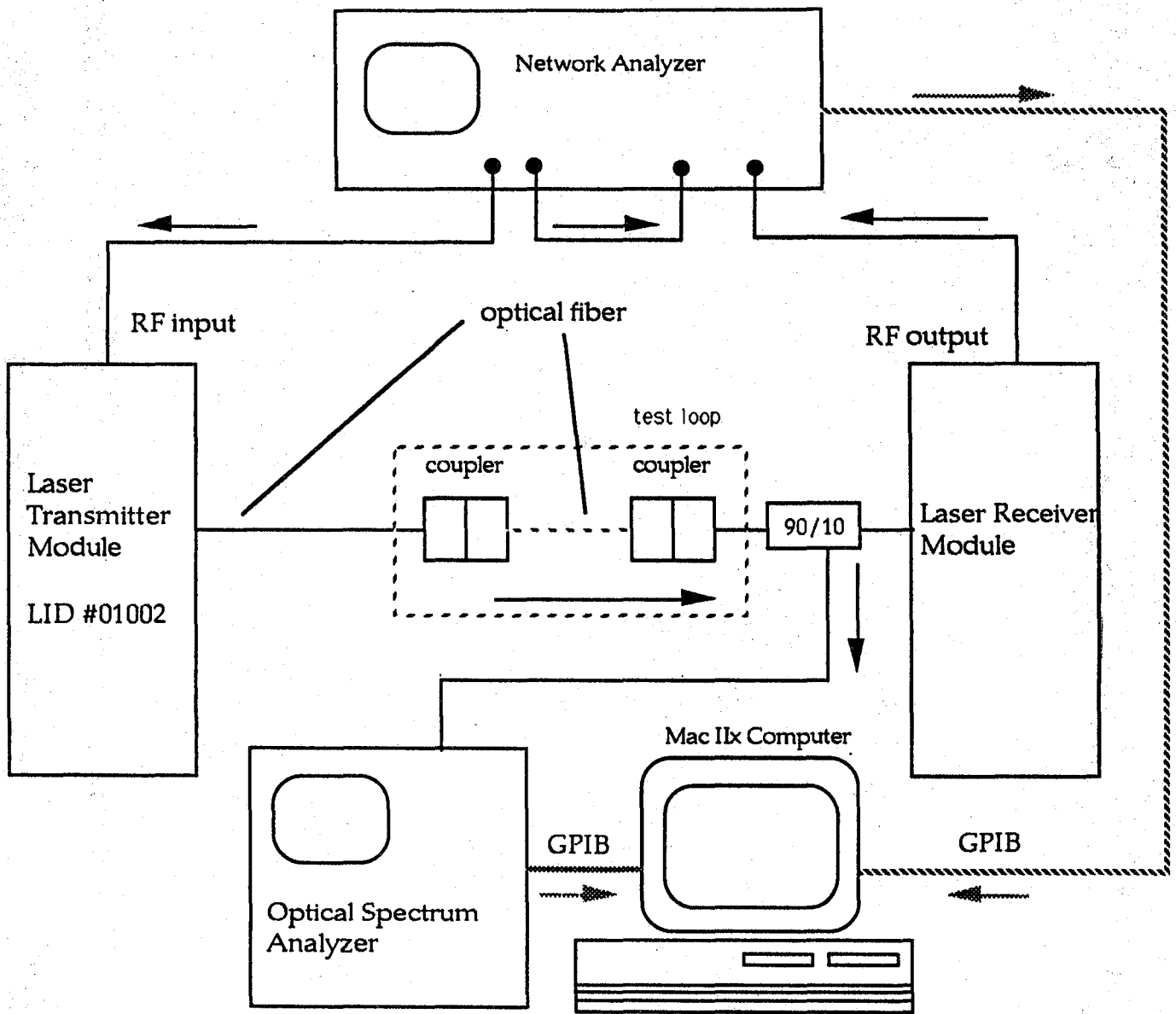

Figure 3.1.1-1 Transmission Mode Experimental Setup.

Appendix A shows selected output data from TMODE experiments.

3.1.2 REFLECTION MODE

Reflection mode studies analyze the modulation spectra transmitted through the test loop and light spectra collected directly at the laser source. Experiments were conducted using a laboratory spool of test fiber, with various numbers of connector pairs on short

jumpers added after the test spool and through one and two loops actual data links from the EDL to the CDSC. Each group of similar experiments included a base line configuration that only utilized the 1 km laboratory spool of fiber. The experimental setup is shown in the Fig. below.

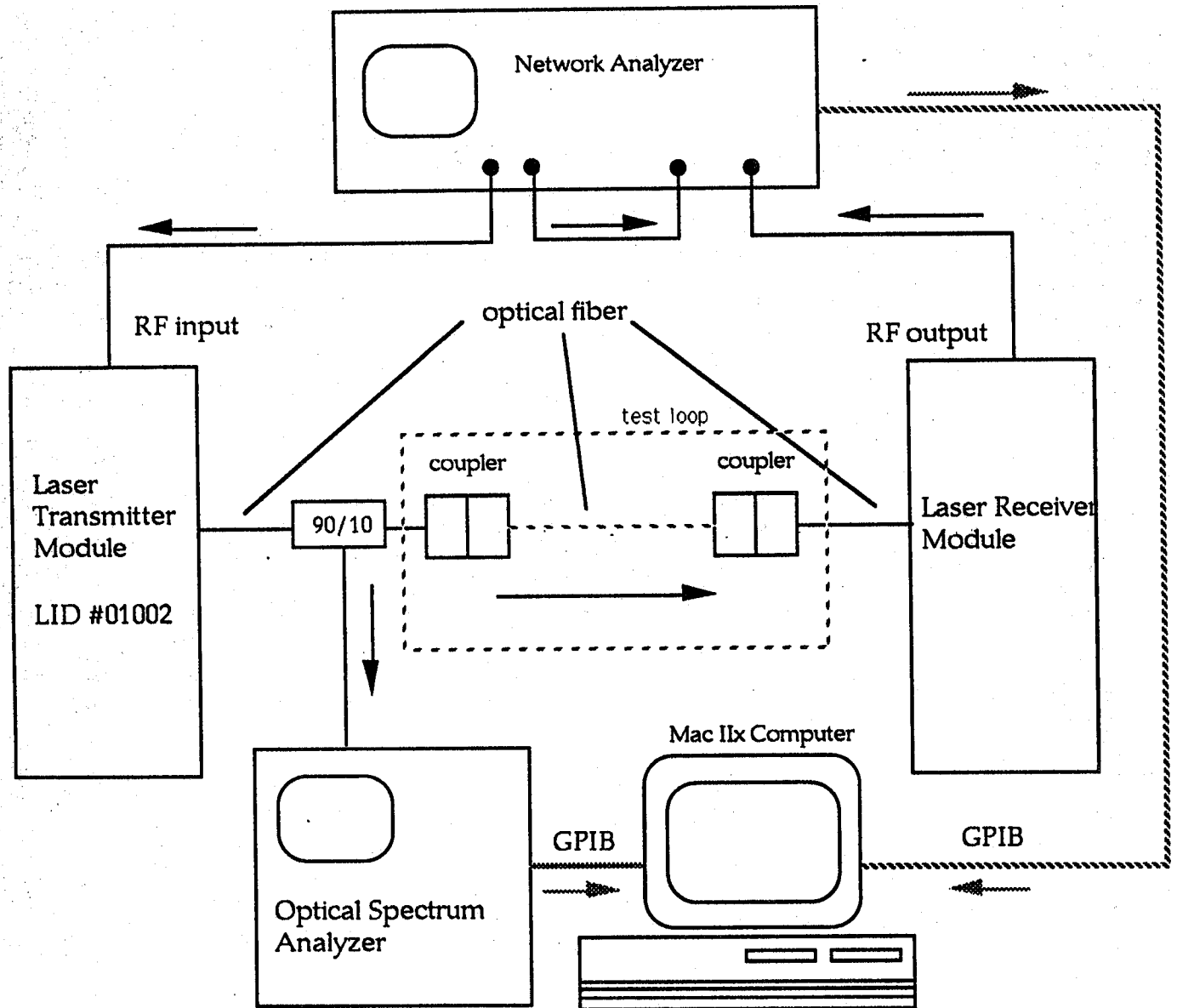

Figure 3.1.2-2 Reflection Mode Experimental Setup

Appendix B shows a selected collection of output data from these reflection mode experiments.

3.2 RESULTS OF STUDIES WITH FREE SPACE LINK IN NETWORK

A study was conducted to explore the effects of quarter wave plates and polarizers in the test link. A test section was constructed that consisted of a free space link with a polarizer and a quarter wave plate oriented at 45 degrees to the axis of the polarizer. The basic setup is shown below:

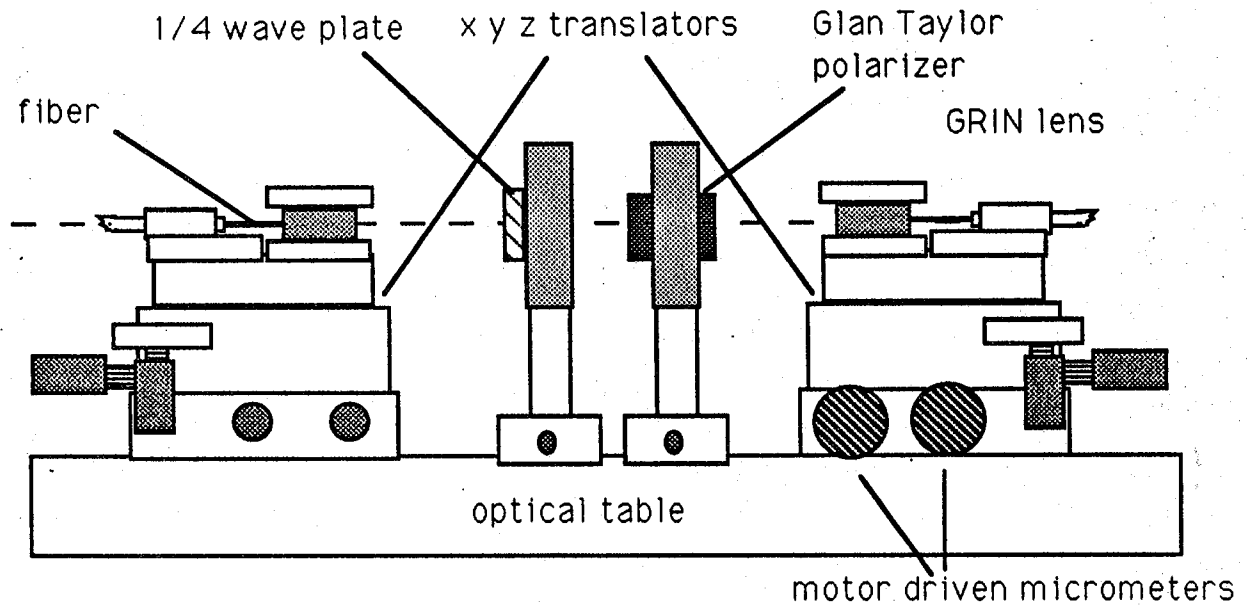

Figure 3.2-1. Free Space Test Link.

RF and optical spectra were collected with this free space section in the optical link and with out in order to compare. A sample of a spectrum taken with the polarizer and 1/4 wave plate is shown below. Eighteen connector pairs were utilized in both setups to create perturbations in the network transmission.

Comparison of RF Transmission Characteristics with Free Space Elements

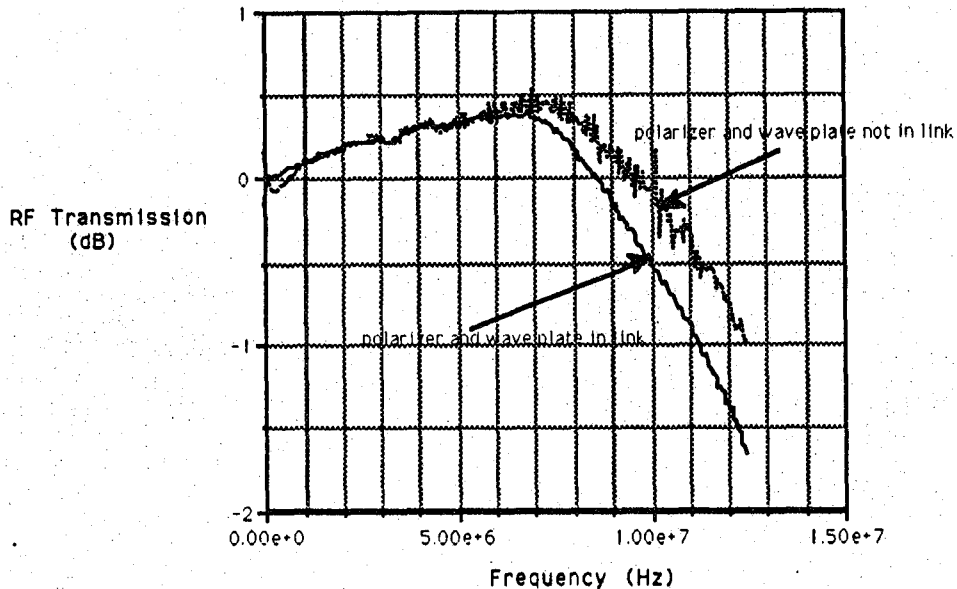

Figure 3.2-2. The effects of elements in Free Space Link on RF Spectrum

This interesting result is just a preliminary view of the kind of things that can be accomplished by studying the insertion of various combinations of free space optical elements into a fiber optic link. It suggests that many further experiments need to be done to try to optimize link performance and help minimize the adverse effects of reflections at connectors.

3.3 RESULTS OF STUDIES USING THE FABRY-PEROT INTERFEROMETER

A limited number of experiments were conducted with the Fabry Perot interferometer. One significant result was the observation of chirp in the modal frequency of the transmission laser with a repetition rate equal to the modulation frequency of the laser. This was observed by setting the Fabry Perot at a fixed transmission frequency thereby selecting one mode of the transmitter laser. Graphs taken from the sampling oscilloscope are shown in Appendix C. The shape of the peak of the modulated waveform could be set by

changing the bias on the piezoelectric element of the interferometer. This conclusively proves that a small chirp is present in the laser output frequency during the time the carrier pulse is on. an estimate of the magnitude of this chirp could be made given time for further experiments and analysis.

IV. CONCLUSIONS

4.0 CONCLUSIONS AND RECOMMENDATIONS FOR FURTHER WORK

This work has both answered questions and suggested new ones. The experiments performed show conclusively that connectors in a fiber optic network do effect the performance of the network if a laser source is utilized. The perturbations increase as more connector pairs are introduced. While a frequency chirp was observed with the Fabry Perot setup, the amount of the chirp is small compared to the spacing between the modes. This conclusion is supported by the many spectra collected over time. Laser modes remained locked in place and modal spacing did not change. Large shifts in energy distribution between modes was noticed. In some cases this was seen when a fiber in the test link was moved several centimeters. Small vibrations did not produce as noticeable an effect. More work needs to be done to quantify these effects especially if fibers are to be employed in systems subject to vibrations, thermal stress or large amplitude mechanical motion during normal operations.

The presence of optical elements such as polarizers, GRIN lenses and wave plates can effect both bandwidth and perturbations caused by connector reflections. Only preliminary experiments have been conducted in the limited time available. The author recommends that these experiments be continued and theories developed to account for such effects in multimode systems. The results of such research could have an impact on the design and implementation of fiber systems at KSC and for the Space Station Project where it is anticipated that large diameter optical fiber will be used.

A considerable effort was made during this project to link the Macintosh IIx computer to the optical spectrum analyzer and the RF spectrum analyzer. As a result of the success of this effort a large amount of data has been collected. More data in fact than can be completely analyzed in the short period of time available during a Summer Faculty Fellowship. It is therefore recommended that data analysis be continued so as to develop more quantitative statistical results of the experiments completed to date.

Appendix A SELECTED DATA OUTPUT FROM TMODE EXPERIMENTS

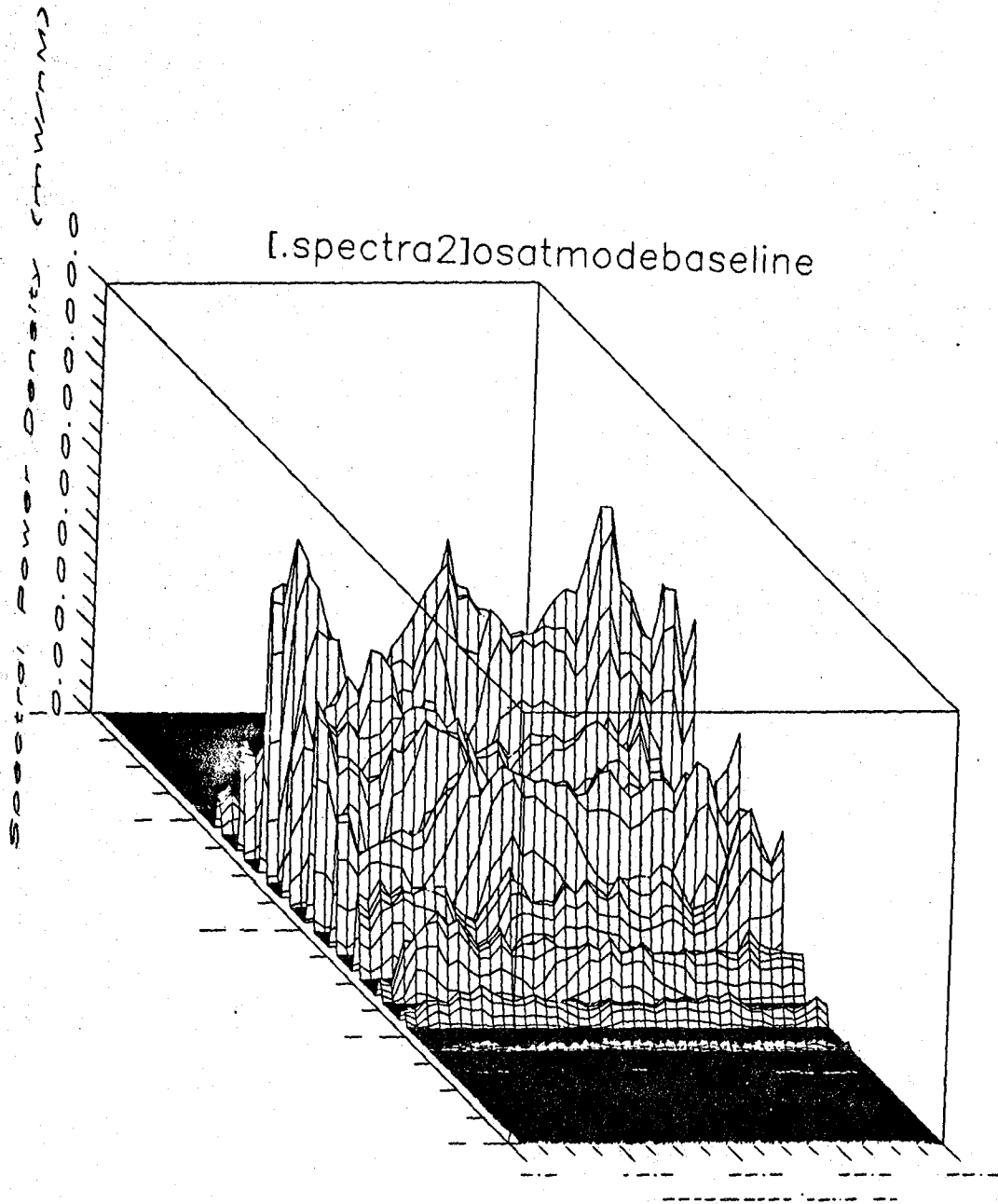

TMODEBASELINE

Tmode no connector pairs added to system. OSA 500 nW, 1.28-1.3 micrometers span. RF 10 Hz to 12.5 MHz .1 dB/div VBW 300 Hz RBW 100Hz. 35 dB variable ATTENUATOR IN LINE. 15 sec between runs.

[.SPECTRA2]RFATMODEBASELINE

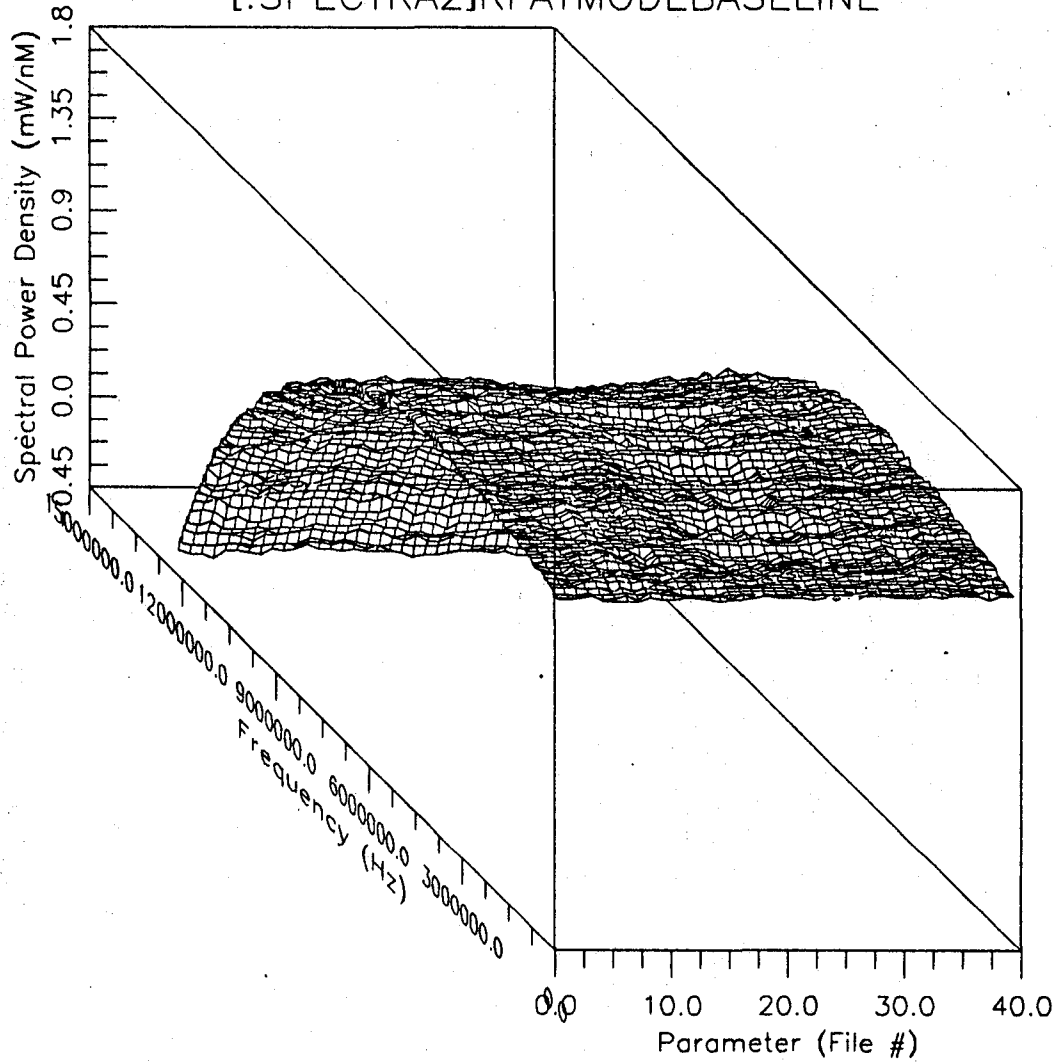

TMODEBASELINE

Tmode no connector pairs added to system. OSA 500 nW, 1.28-1.3 micrometers span. RF 10 Hz to 12.5 MHz .1 dB/div VBW 300 Hz RBW 100Hz. 35 dB variable ATTENUATOR IN LINE. 15 sec between runs.

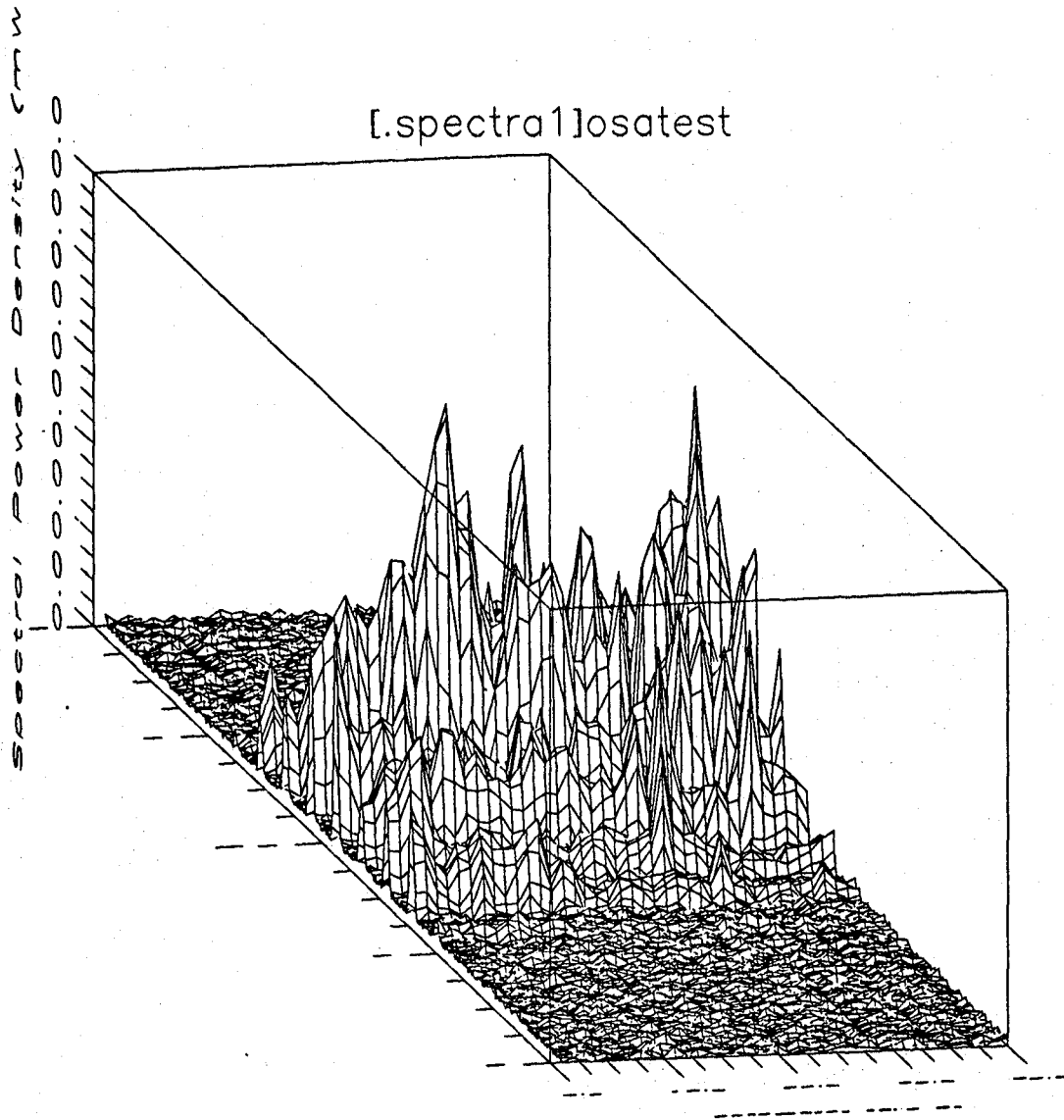

RFATEST

Tmode 20 connector pairs added to system. OSA 2.5 nW, 1.28-1.3 micrometers span. RF 10 Hz to 12.5 MHz .1 dB/div VBW 300 Hz RBW 100Hz. NO ATTENUATOR IN LINE.

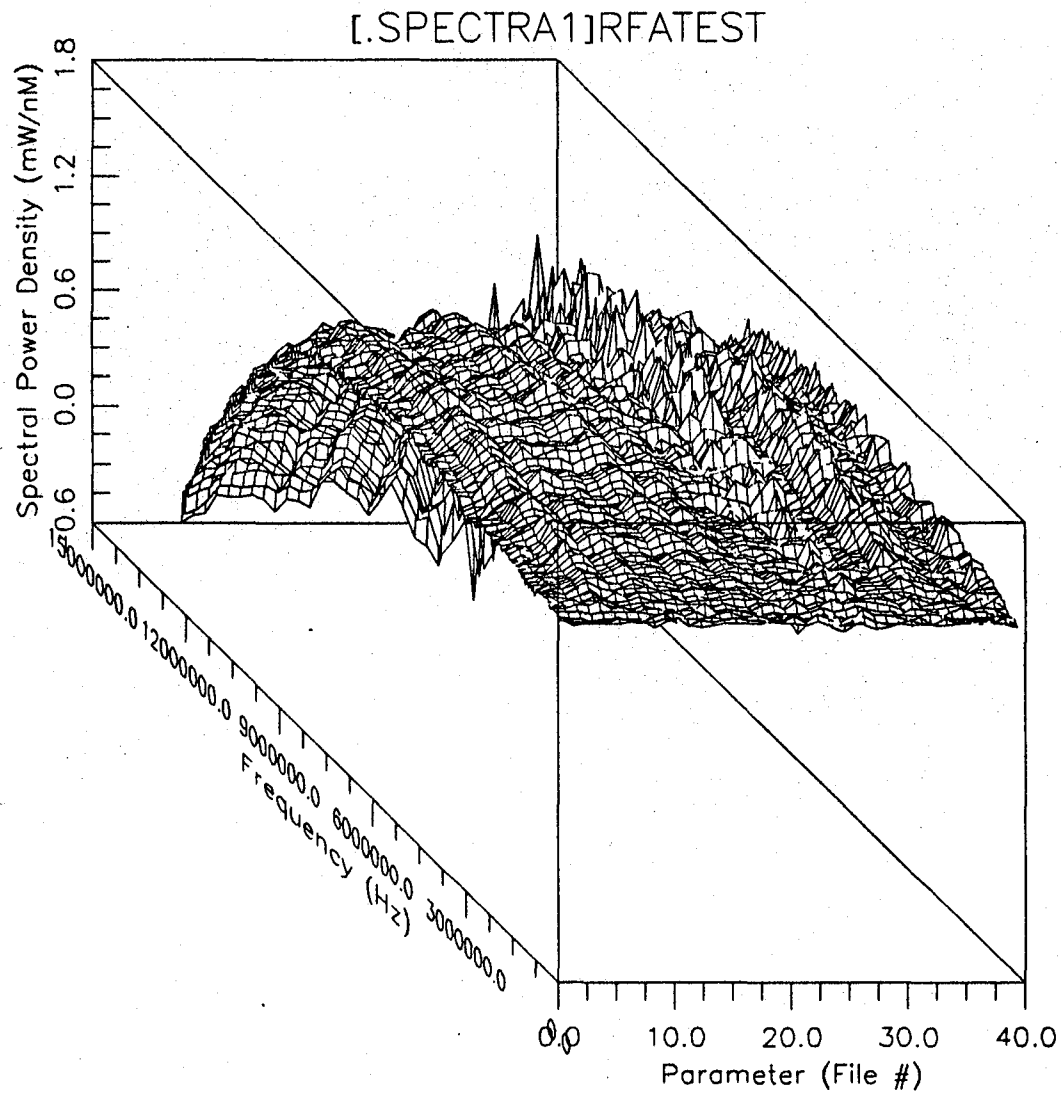

RFATEST

Tmode 20 connector pairs added to system. OSA 2.5 nW, 1.28-1.3 micrometers span. RF 10 Hz to 12.5 MHz .1 dB/div VBW 300 Hz RBW 100Hz. NO ATTENUATOR IN LINE.

Appendix B

SELECTED DATA OUTPUT FROM RMODE EXPERIMENTS

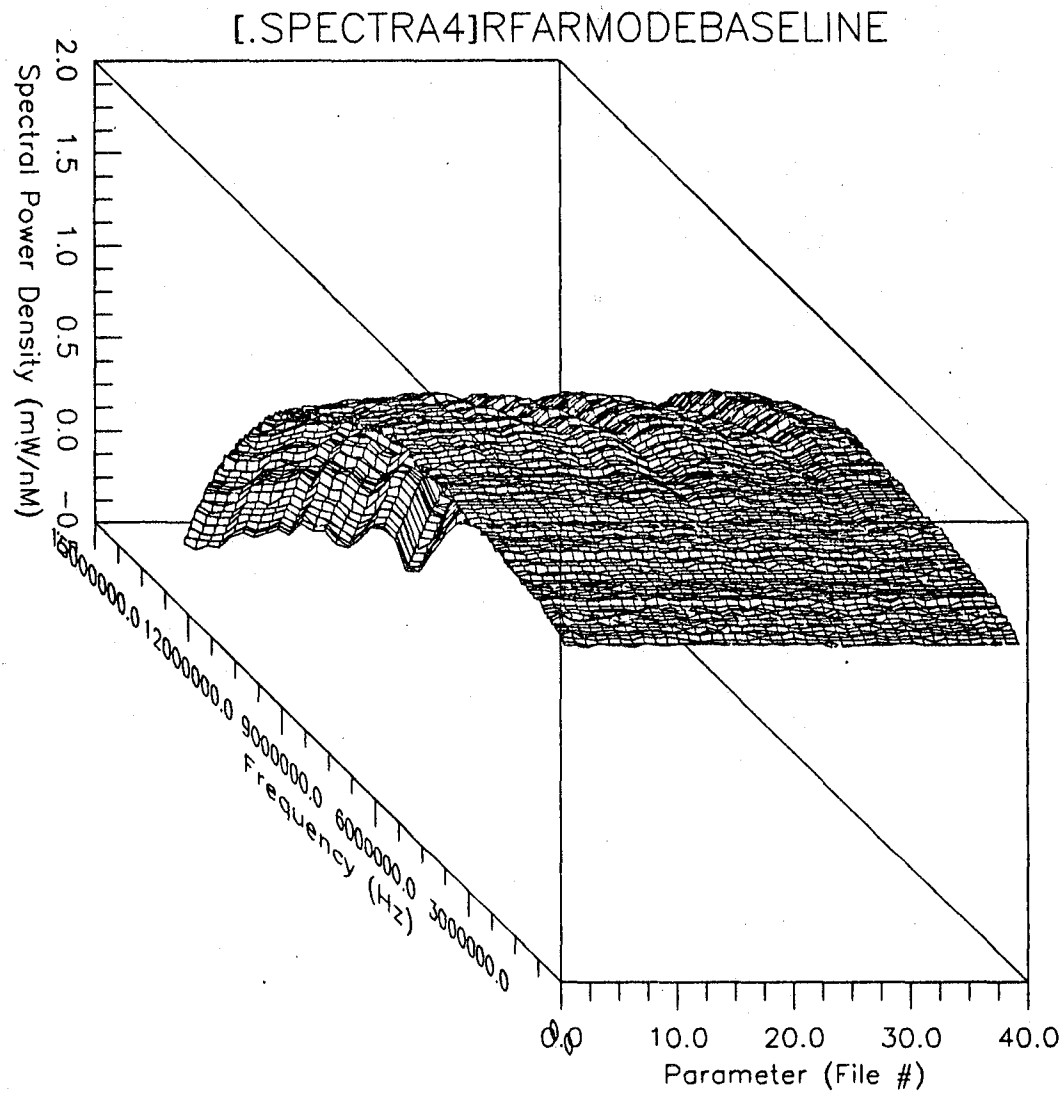

RMODE BASELINE

Rmodebaseline system no extra connectors AS WELL AS 20 dB variable ATTENUATOR IN LINE. OSA 500 nW, 1.28-1.3 micrometers span. RF 10 Hz to 12.5 MHz .1 dB/div VBW 300 Hz RBW 100Hz. 15 sec between runs.

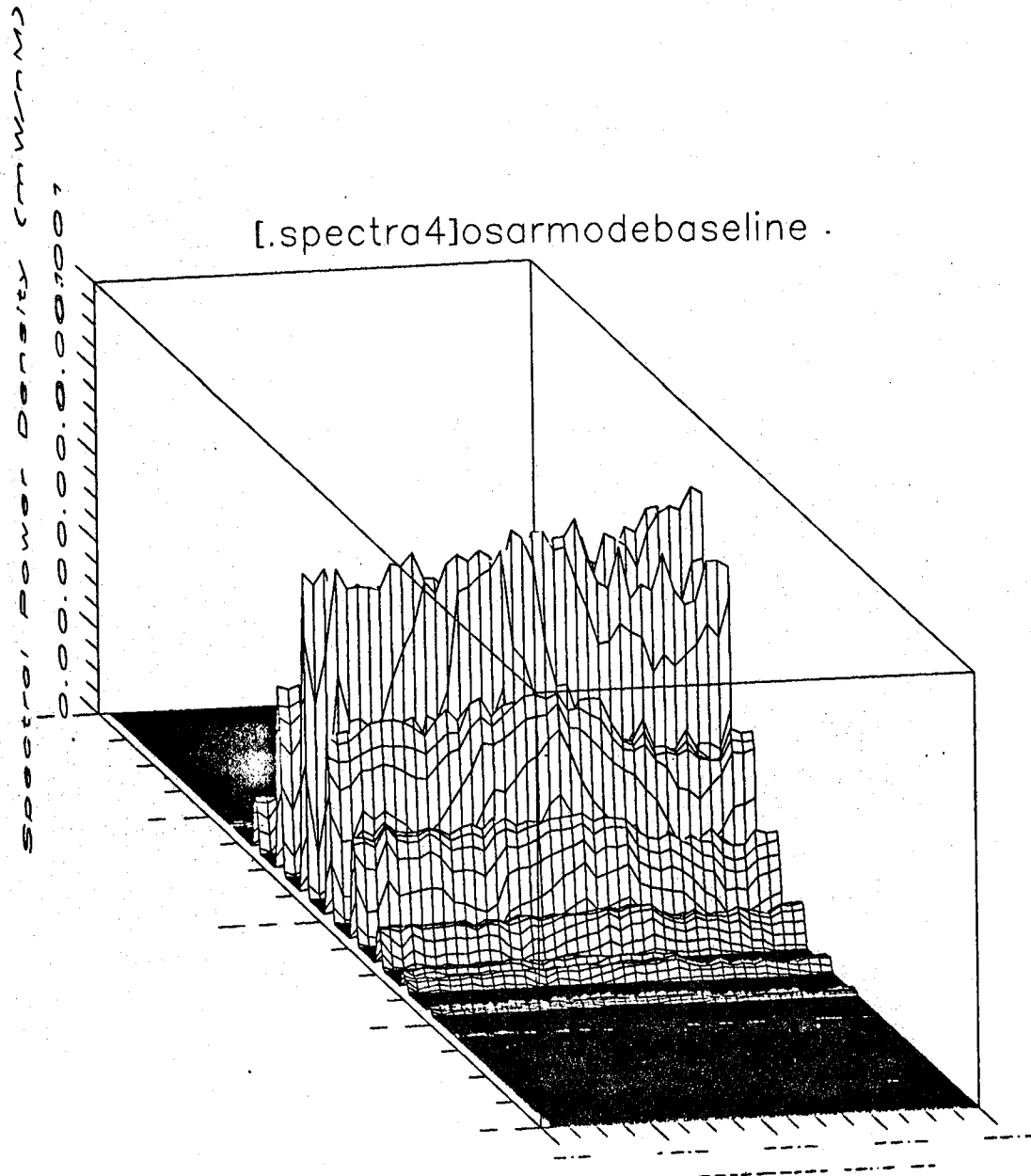

RMODE BASELINE

Rmodebaseline system no extra connectors AS WELL AS 20 dB variable ATTENUATOR IN LINE. OSA 500 nW, 1.28-1.3 micrometers span. RF 10 Hz to 12.5 MHz .1 dB/div VBW 300 Hz RBW 100Hz. 15 sec between runs.

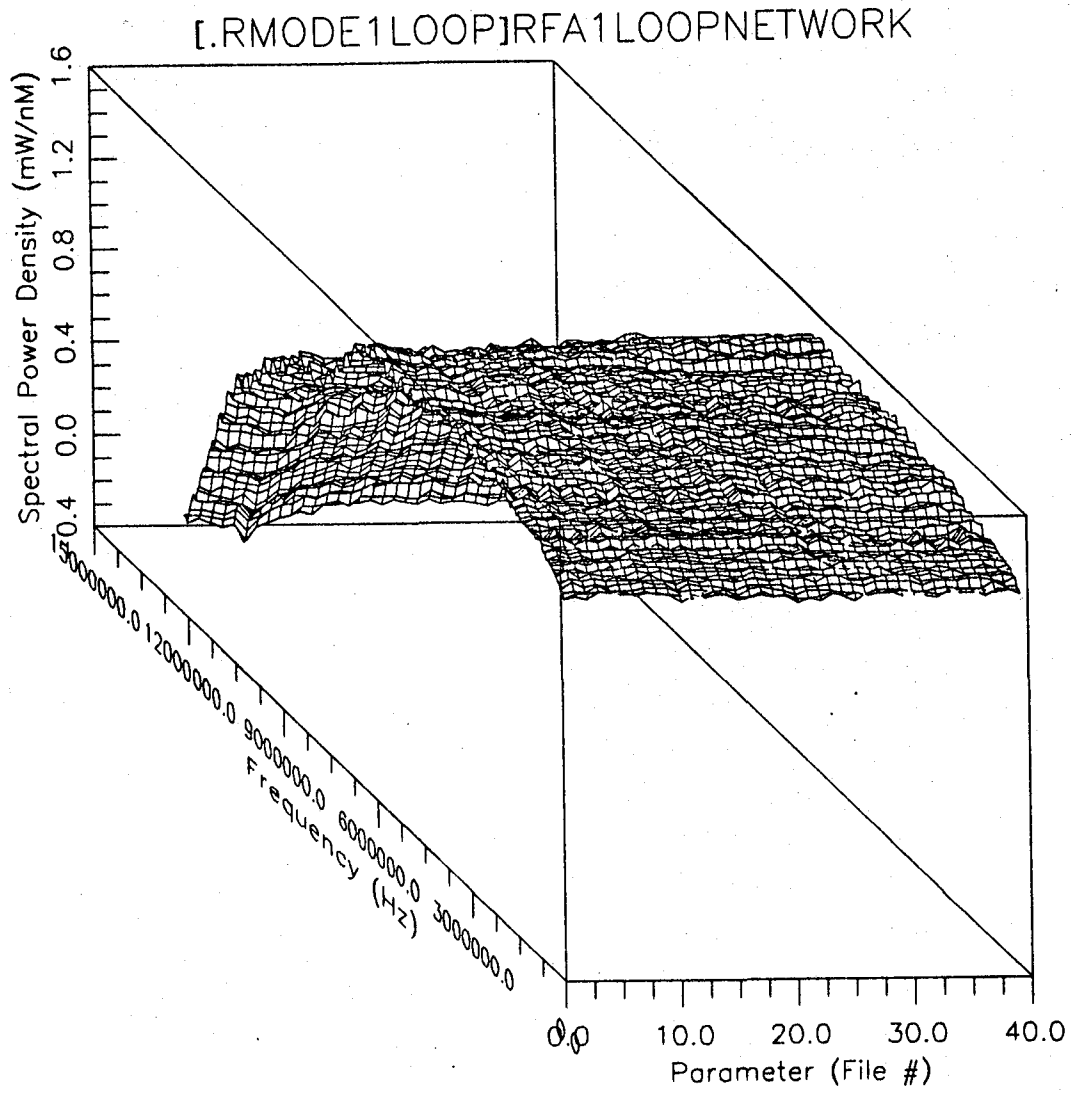

RMODE1LOOP

Rmode system 1 loop network CDSC and back. OSA 500 nW, 1.28-1.3 micrometers span. RF 10 Hz to 12.5 MHz .2 dB/div VBW 300 Hz RBW 100Hz. 15 sec between runs.

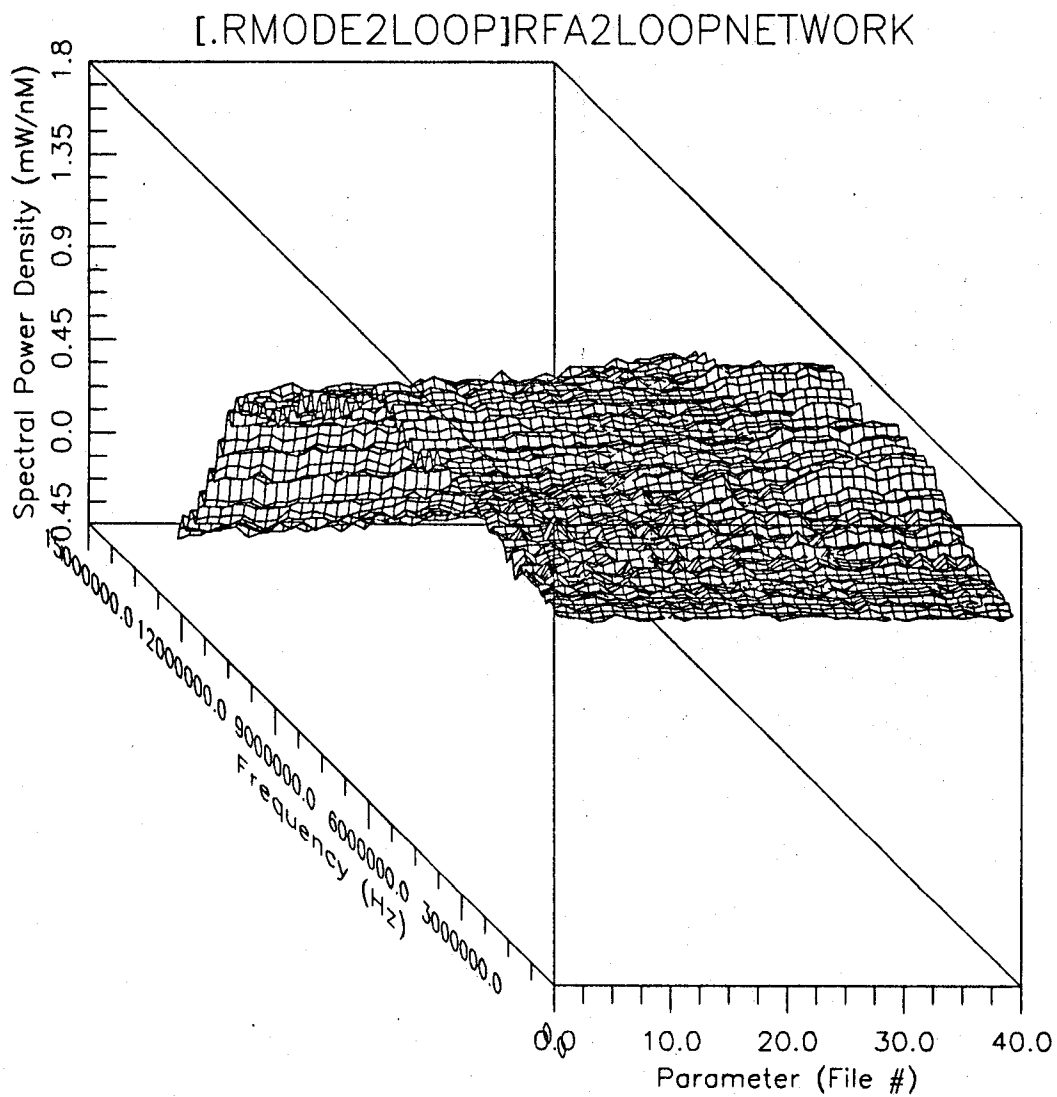

RMODE2LOOP

Rmode system 2 loop network CDSC and back. OSA 500 nW, 1.28-1.3 micrometers span. RF 10 Hz to 12.5 MHz .2 dB/div VBW 300 Hz RBW 100Hz. 15 sec between runs. 6-7 13.5 dB and 7-8 12.5 dB attenuation 1loop run was 6-7 only. RF referenced to short cable.

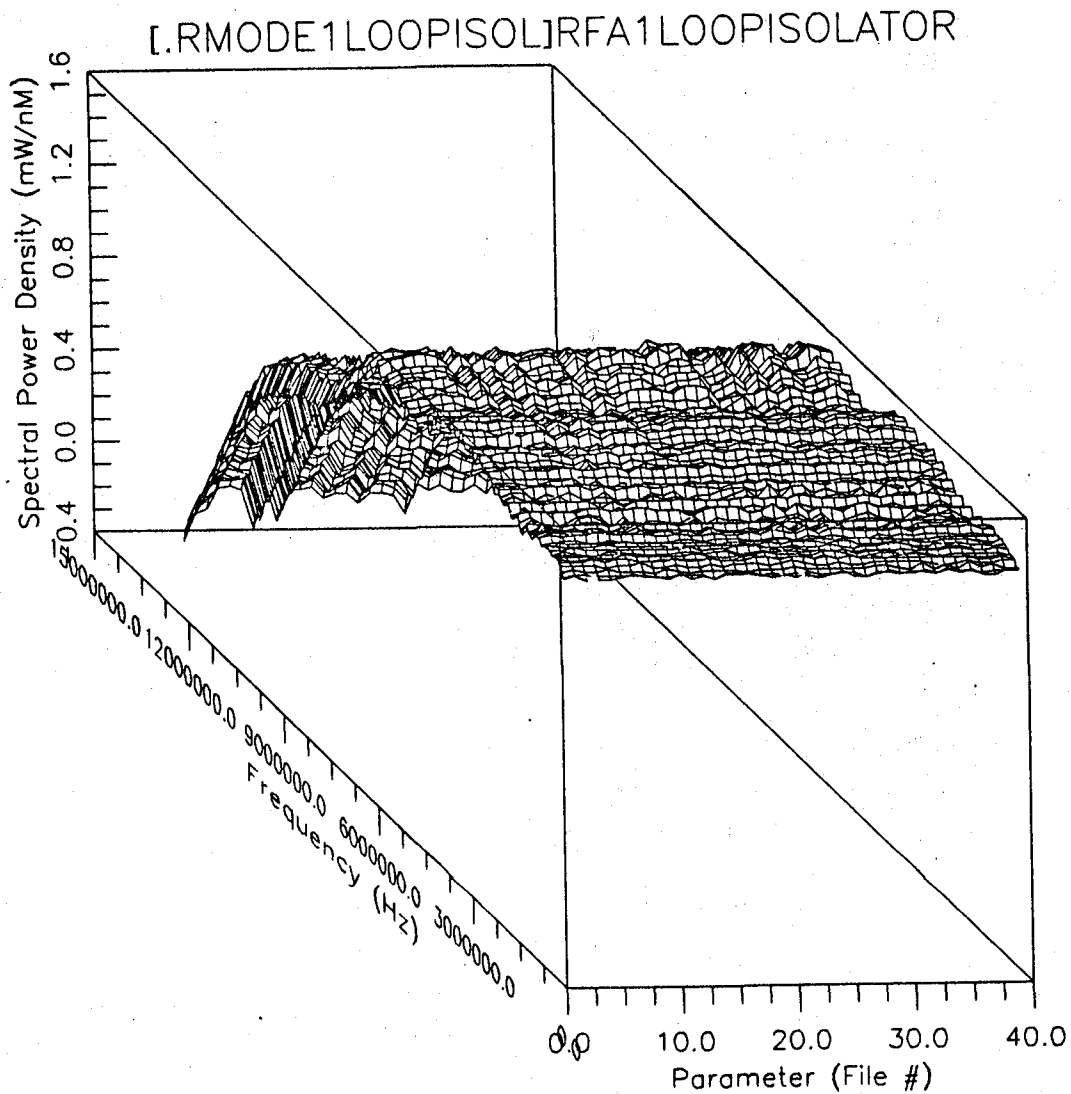

1LOOPISOLATOR

Rmode system 1 loop network CDSC and back WITH OPTICAL ISOLATOR ISOWAVE 113 POZ S/N 0391. AT TX SIDE. OSA 500 nW, 1.28-1.3 micrometers span. RF 10 Hz to 12.5 MHz .2 LOOP TOO MUCH ATTENUATION FOR RX dB/div VBW 300 Hz RBW 100Hz. 15 sec between runs. 6-7 13.5 dB and 7-8 12.5 dB .2attenuation 1loop run was 6-7 only. RF referenced to short cable.

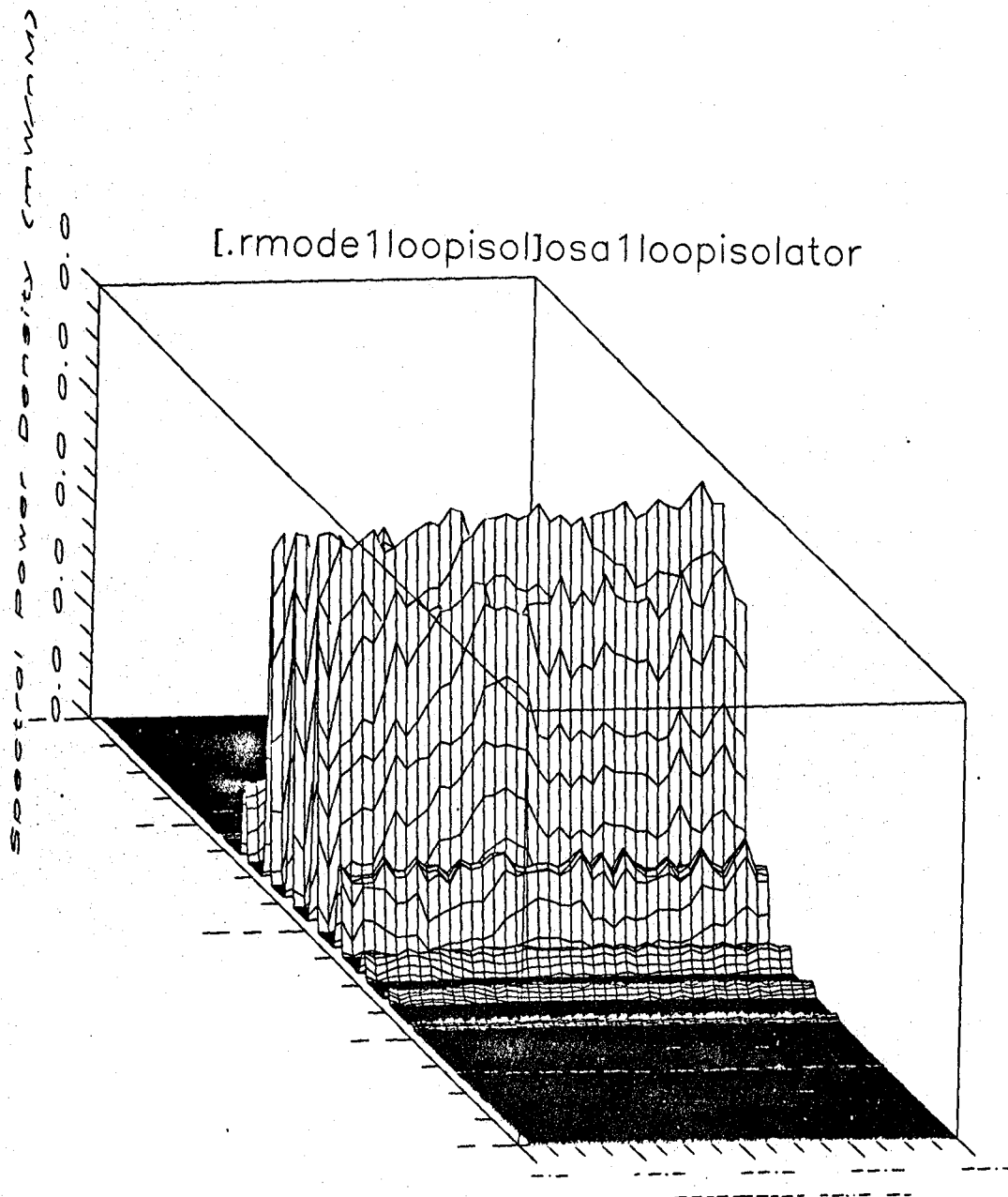

1 LOOPISOLATOR

Rmode system 1 loop network CDSC and back WITH OPTICAL ISOLATOR ISOWAVE 113 POZ S/N 0391. AT TX SIDE. OSA 500 nW, 1.28-1.3 micrometers span. RF 10 Hz to 12.5 MHz .2 LOOP TOO MUCH ATTENUATION FOR RX dB/div VBW 300 Hz RBW 100Hz. 15 sec between runs. 6-7 13.5 dB and 7-8 12.5 dB .2attenuation 1 loop run was 6-7 only. RF referenced to short cable.

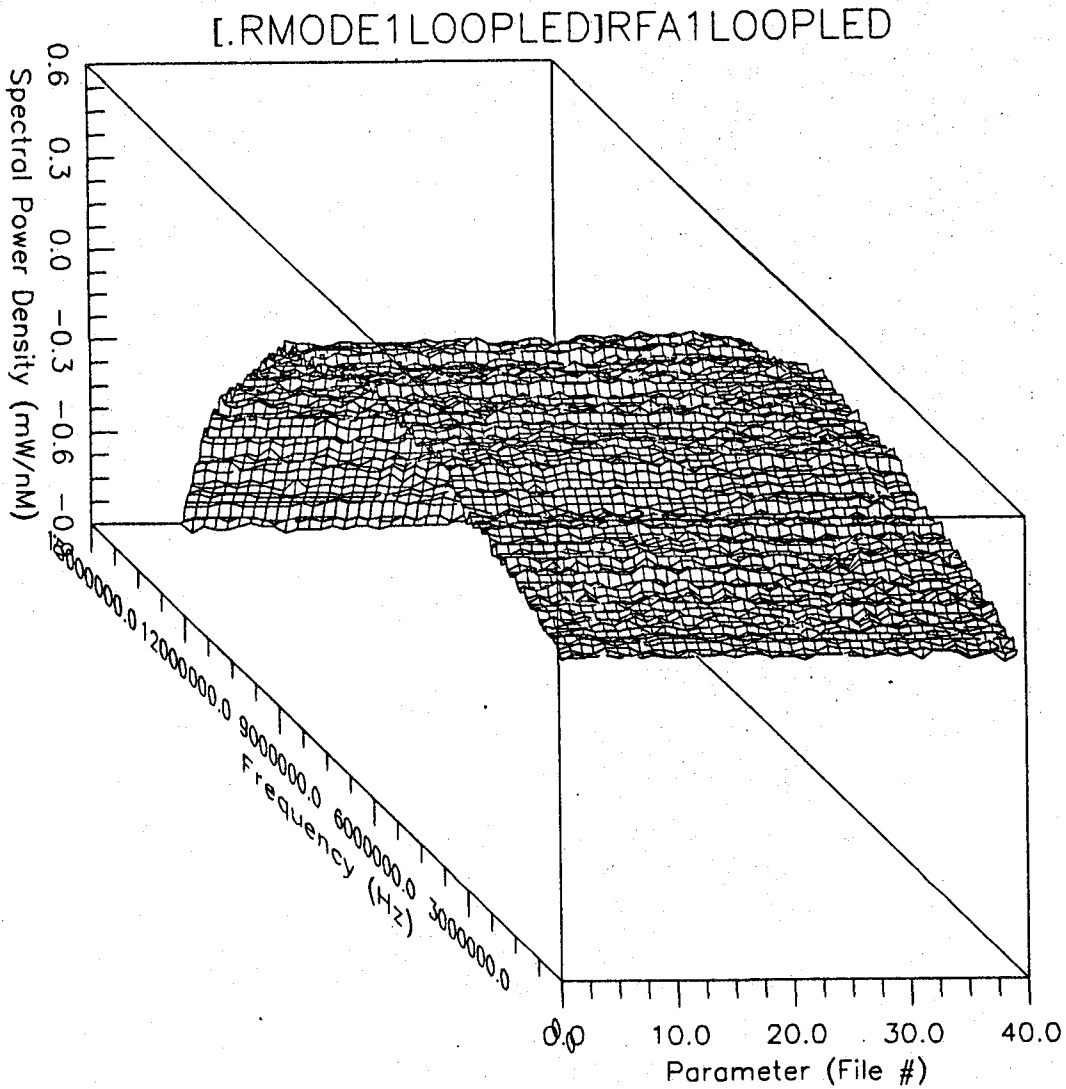

1 LOOPLED

LED 01400 . Rmode system 1 loop network CDSC and back one connector removed in frame room. OSA 1 nW, 1.0-1.5 micrometers span. RF 10 Hz to 12.5 MHz .2 LOOP TOO MUCH ATTENUATION FOR RX dB/div VBW 300 Hz RBW 100Hz. 15 sec between runs. 6-7 13.5 dB and 7-8 12.5 dB .2attenuation 1 loop run was 6-7 only. RF referenced to short cable.

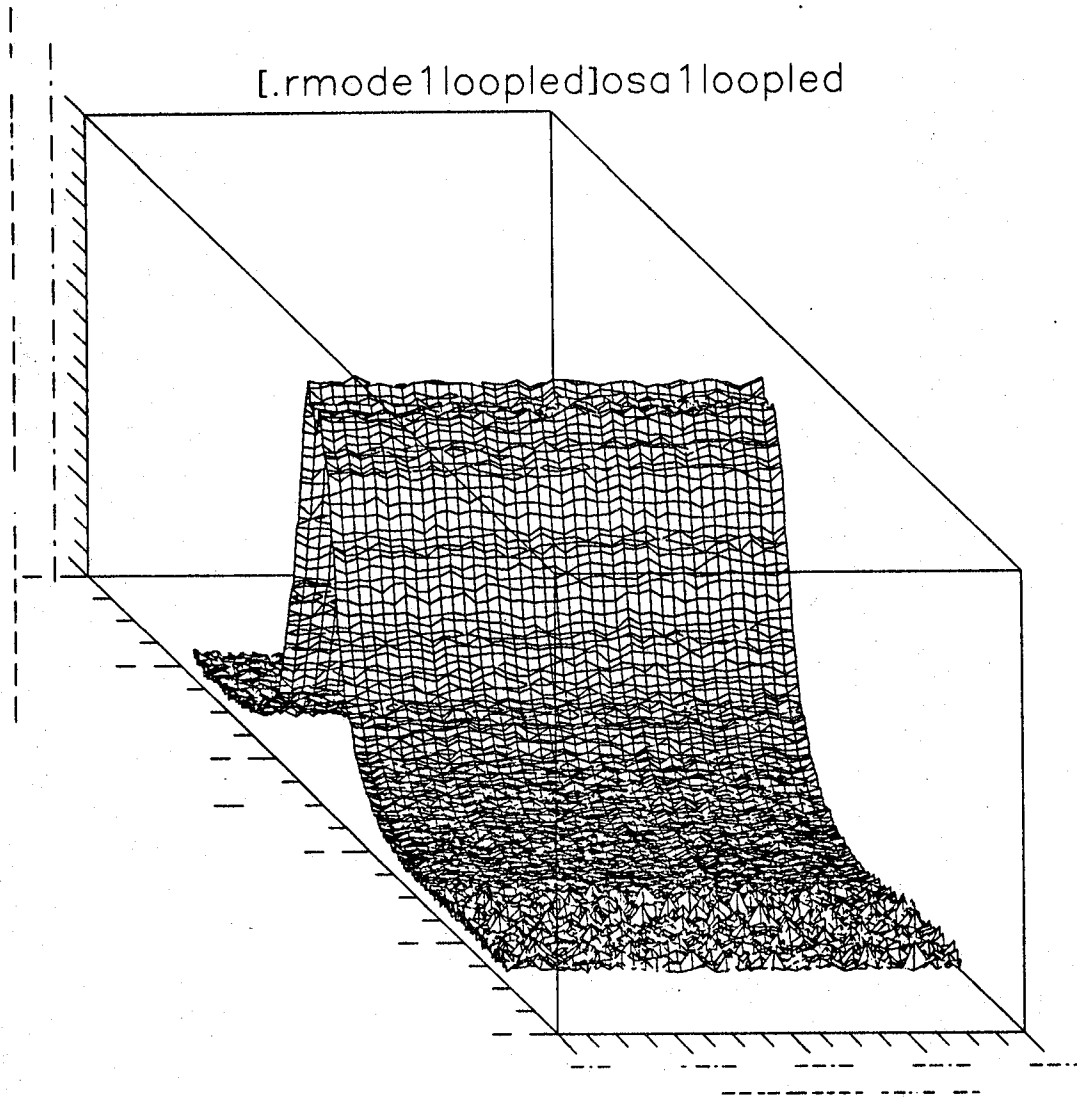

1LOOPLED

LED 01400 . Rmode system 1 loop network CDSC and back one connector removed in frame room. OSA 1 nW, 1.0-1.5 micrometers span. RF 10 Hz to 12.5 MHz .2 LOOP TOO MUCH ATTENUATION FOR RX dB/div VBW 300 Hz RBW 100Hz. 15 sec between runs. 6-7 13.5 dB and 7-8 12.5 dB .2attenuation 1loop run was 6-7 only. RF referenced to short cable.

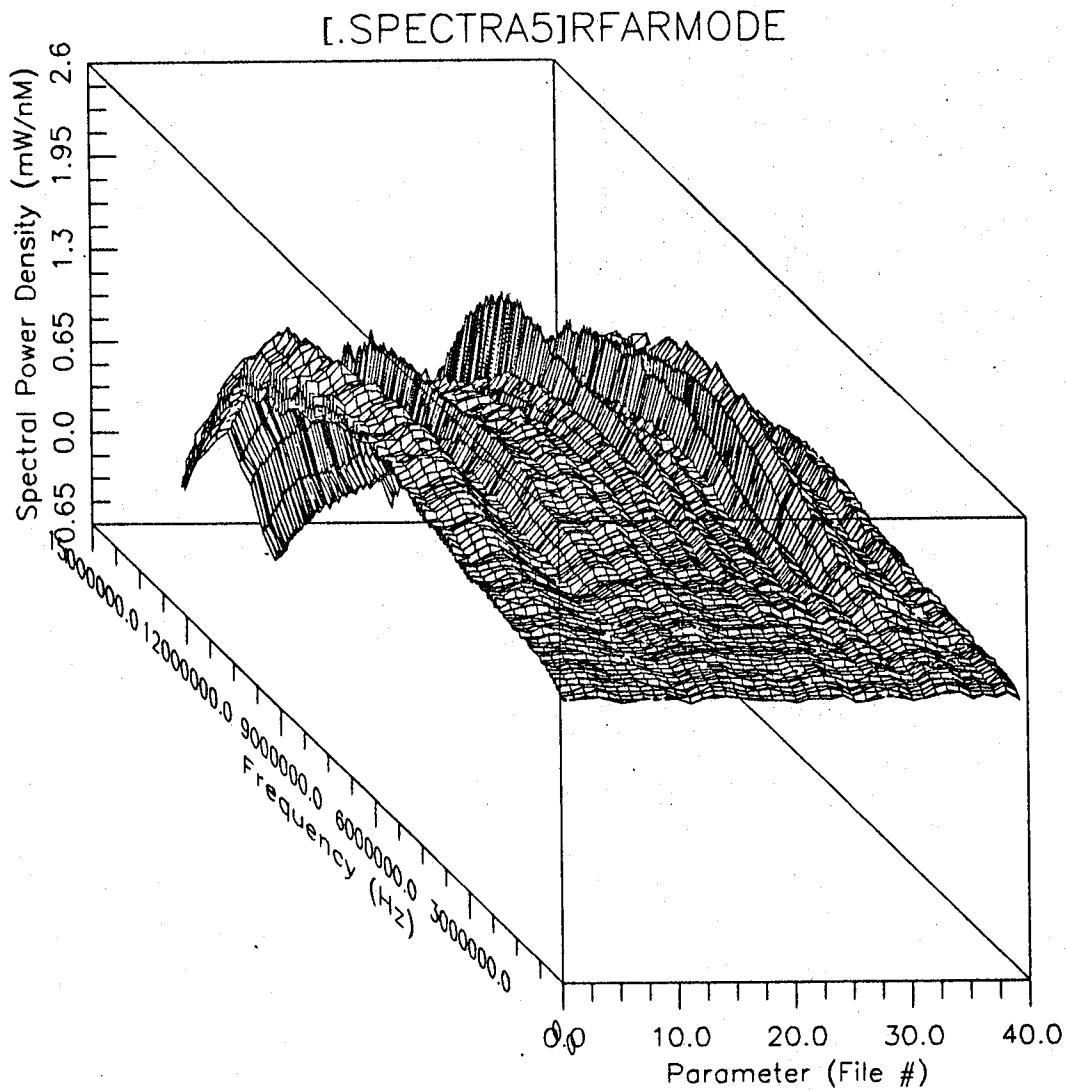

RMODE

Rmode system 20 extra connectors AS WELL AS 0 dB variable ATTENUATOR IN LINE. OSA 500 nW, 1.28-1.3 micrometers span. RF 10 Hz to 12.5 MHz .1 dB/div VBW 300 Hz RBW 100Hz. 15 sec between runs.

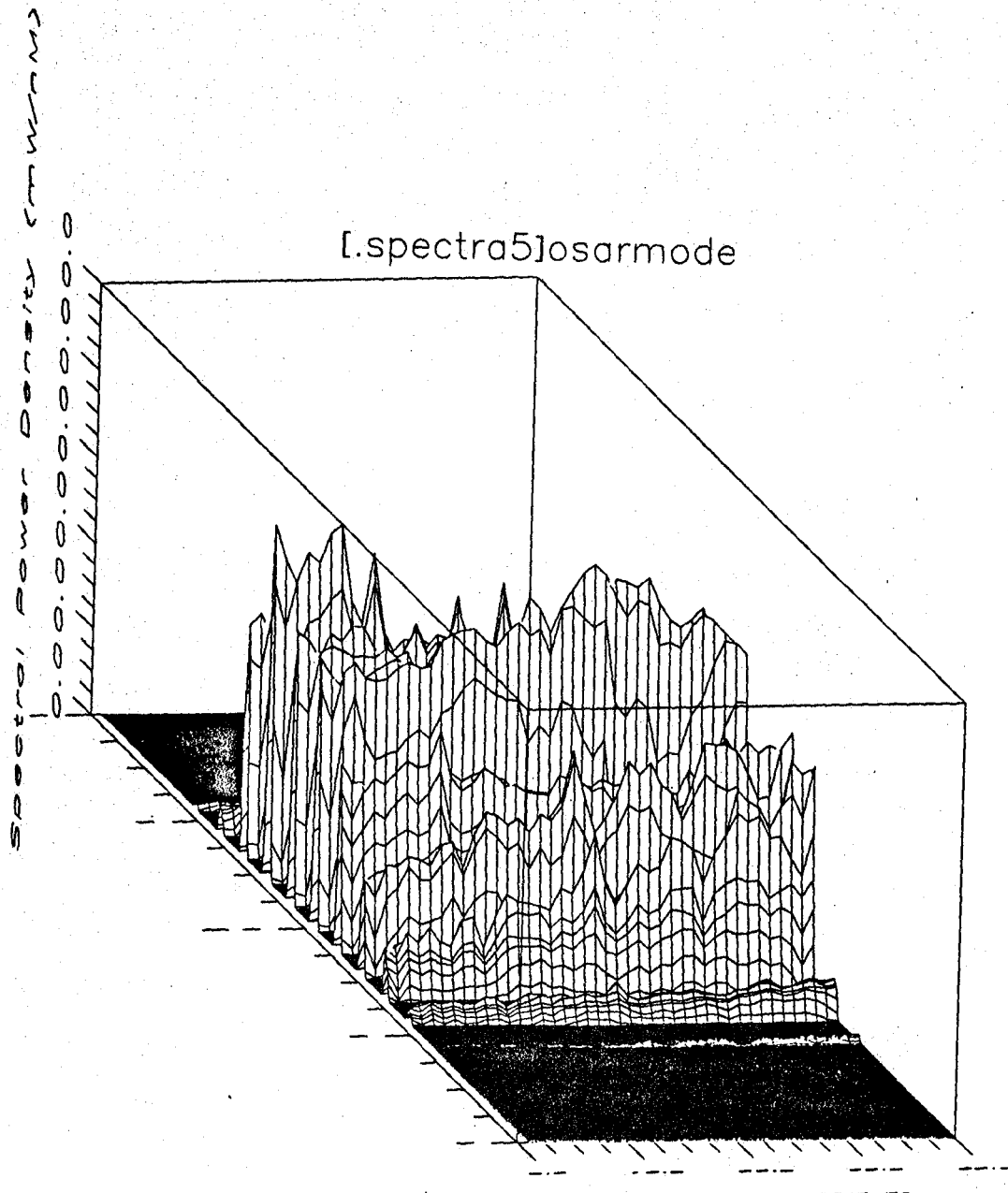

RMODE

Rmode system 20 extra connectors AS WELL AS 0 dB variable ATTENUATOR IN LINE. OSA 500 nW, 1.28-1.3 micrometers span. RF 10 Hz to 12.5 MHz .1 dB/div VBW 300 Hz RBW 100Hz. 15 sec between runs.

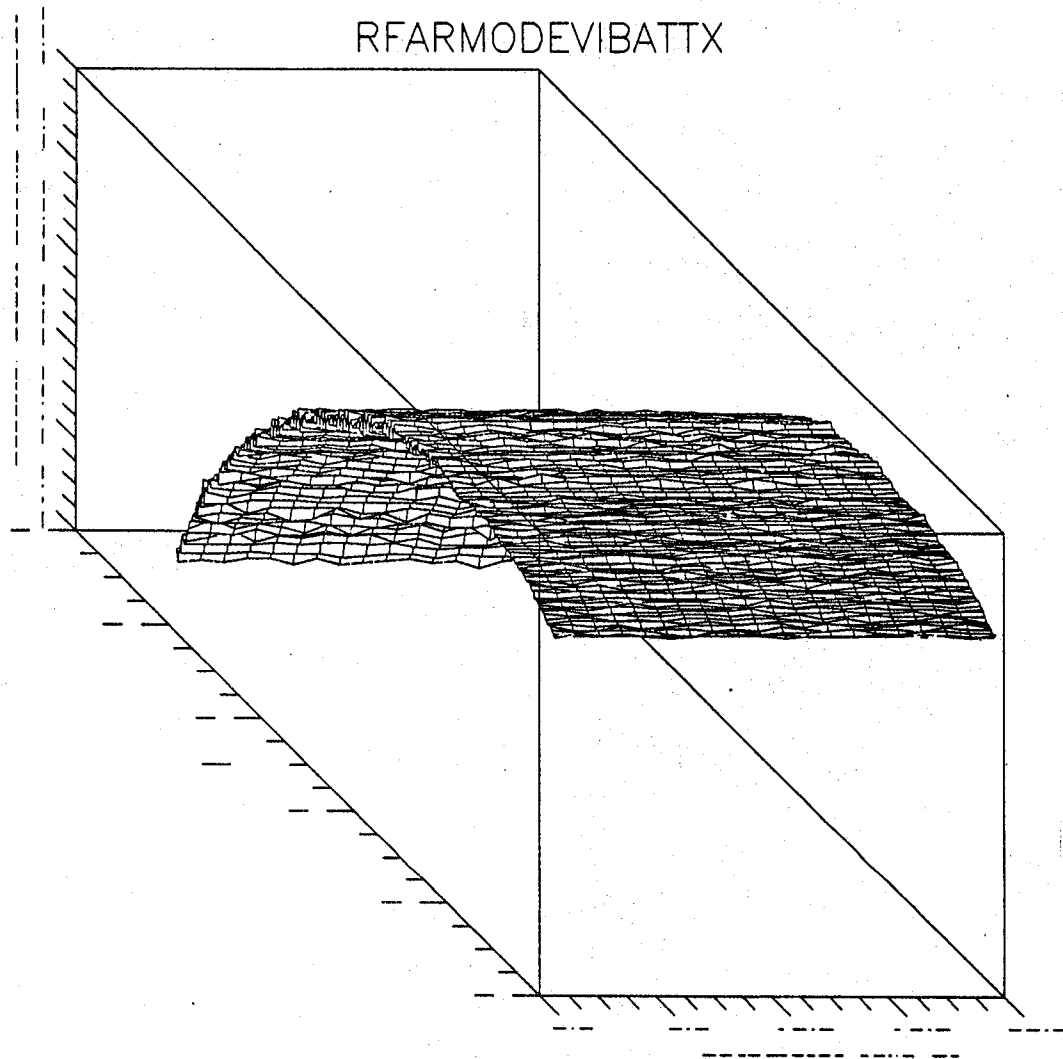

RMODEVIBATTX

Reflection mode. TX to fiber jumper connected to speaker to 90 10
 splitter to 15 dB atten to 1km spool to RX. OSA 1.28 micrometers to
 1.3 micrometers 500 nW. RFA 100 TO 12.5 MHz. .2dB /div RBW 100
 VBW 300. Speaker driven 100 Hz +12dBm.

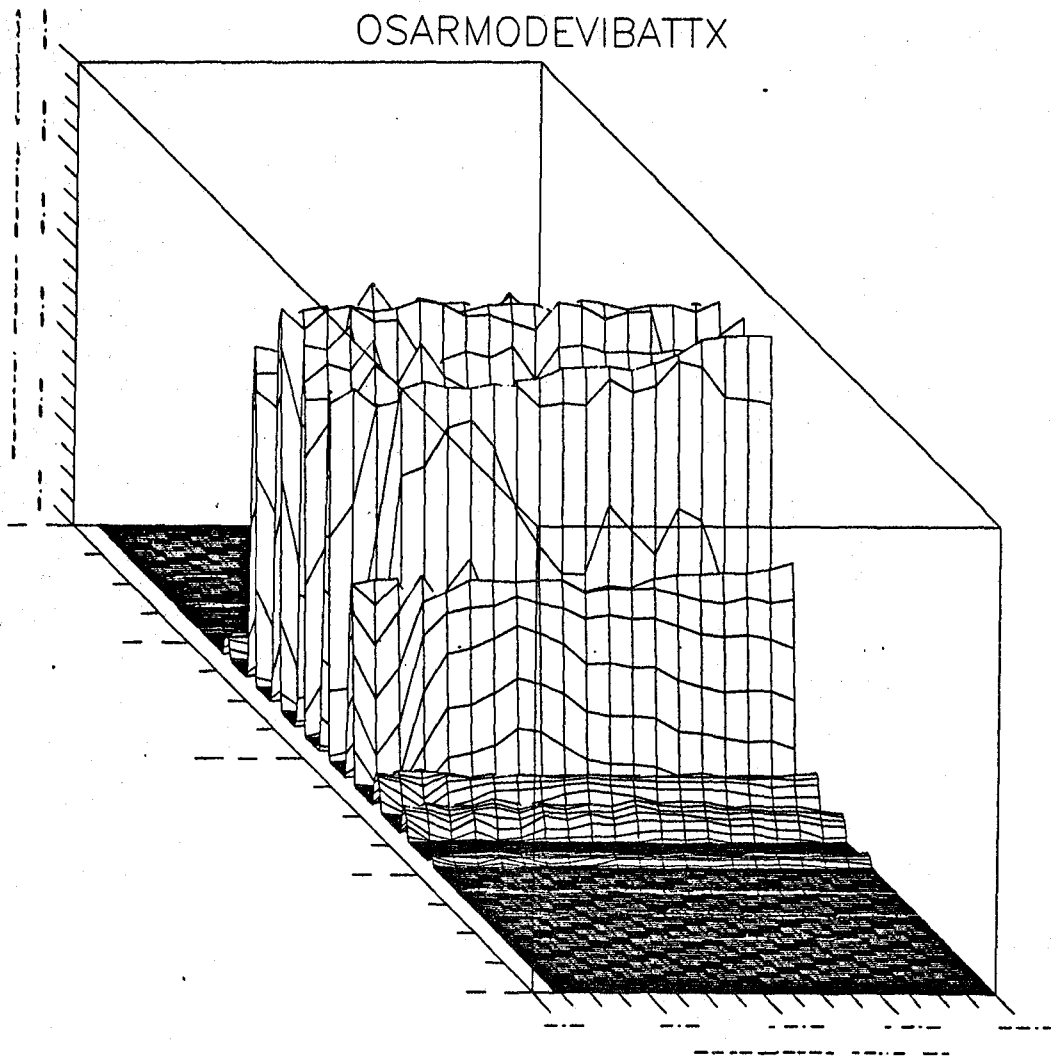

RMODEVIBATTX

Reflection mode. TX to fiber jumper connected to speaker to 90 10
 splitter to 15 dB atten to 1km spool to RX . OSA 1.28 micrometers to
 1.3 micrometers 500 nW. RFA 100 TO 12.5 MHz. .2dB /div RBW 100
 VBW 300. Speaker driven 100 Hz +12dBm.

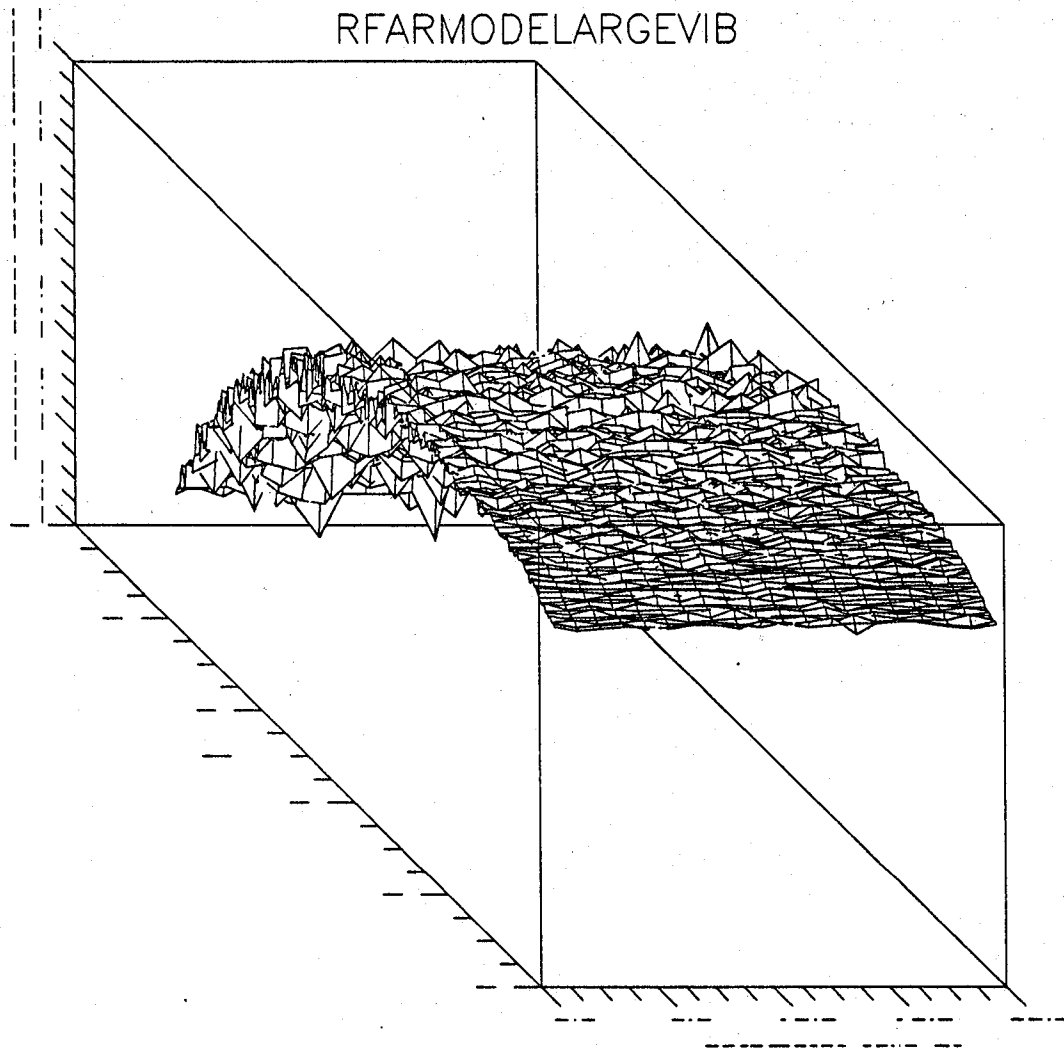

RMODELARGEVIB

Reflection mode. Manual vibration (10-20cm) of jumper connected to 90 10 splitter to 15 dB atten to 1km spool to RX . OSA 1.28 micrometers to 1.3 micrometers 500 nW. RFA 100 TO 12.5 MHz. 0.2dB /div RBW 100 VBW 300.

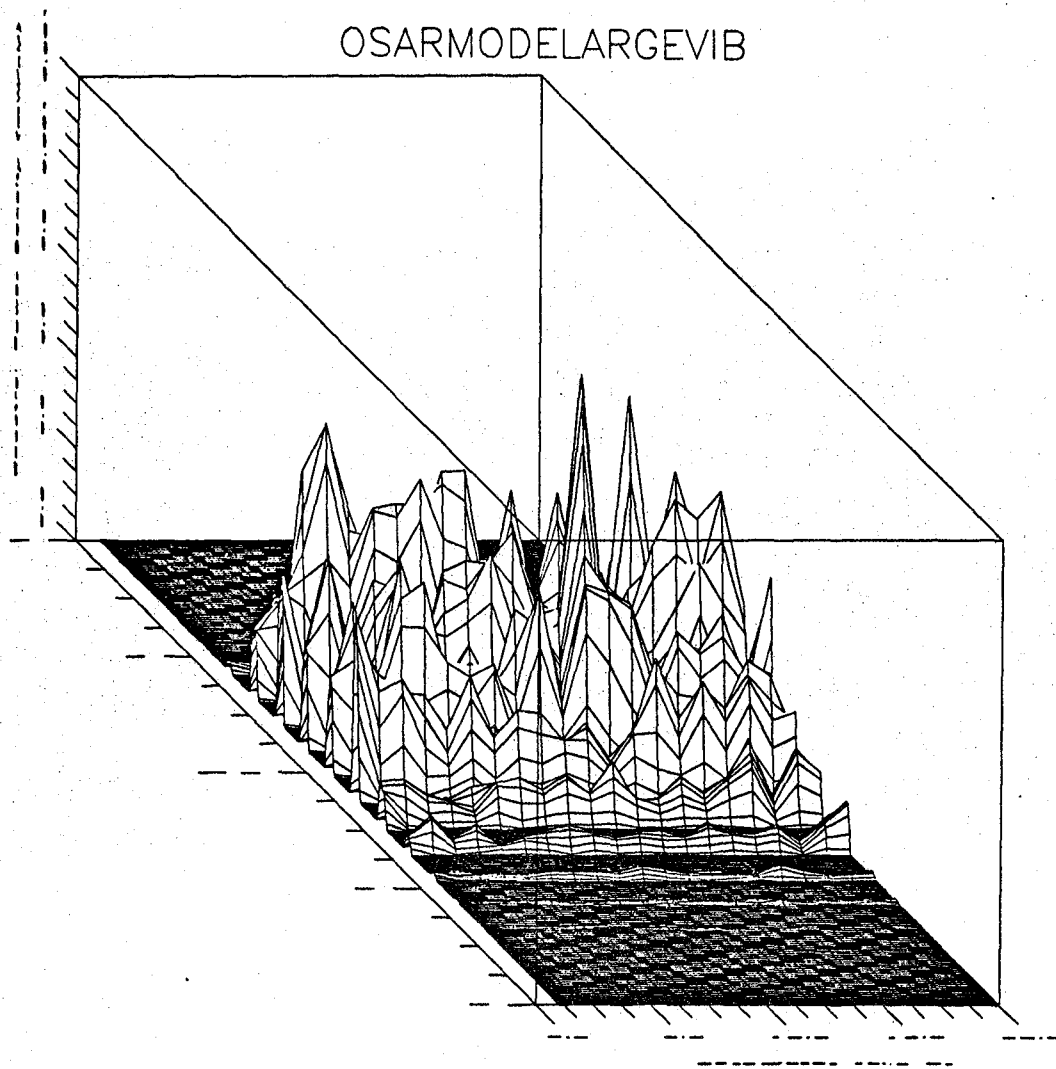

RMODELARGEVIB

Reflection mode. Manual vibration (10-20cm) of jumper connected to 90 10 splitter to 15 dB atten to 1km spool to RX. OSA 1.28 micrometers to 1.3 micrometers 500 nW. RFA 100 TO 12.5 MHz. 0.2dB /div RBW 100 VBW 300.

Appendix C

HIGH SPEED VARIATIONS IN CARRIER OBSERVED
USING FABRY PEROT INTERFEROMETER

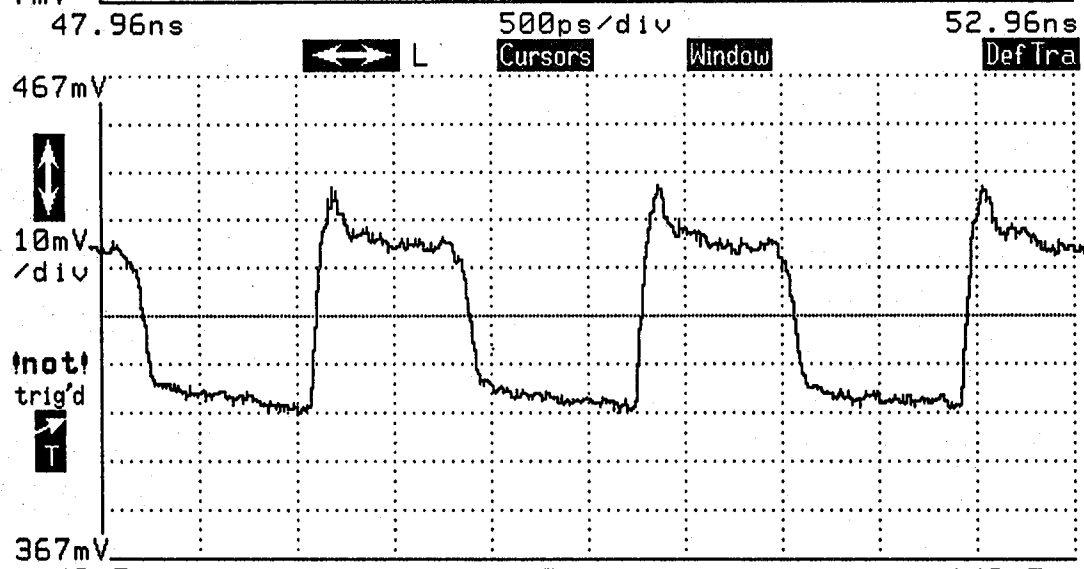
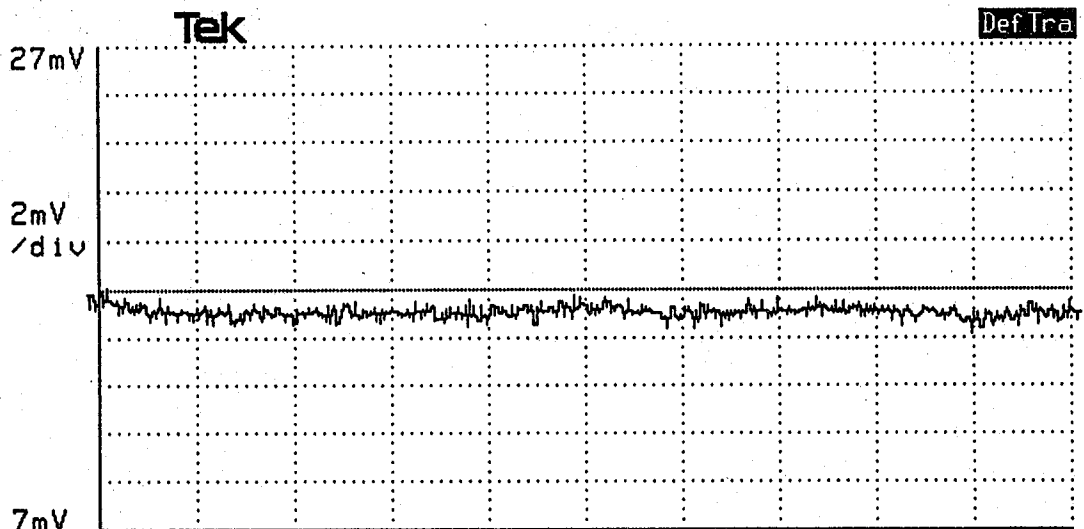

Vertical Desc	Horizontal Desc	Acquire Desc	Lower Graticule	Main Size
Avg(M3*25)	Main	Stopped	Dual	10ns/div
High Prec @	512 pts		s,V	Main Pos
Sampling	Window	Save Trace	More...	Remove/ClrPan/
Head Fnc's	Mode	Desc		Trace 2 Zoom
			Trace Status	Avg(M3*25) off
				Main

LASER MODULATION FABRY PEROT VOLTAGE 3.0201
 BASELINE NETWORK

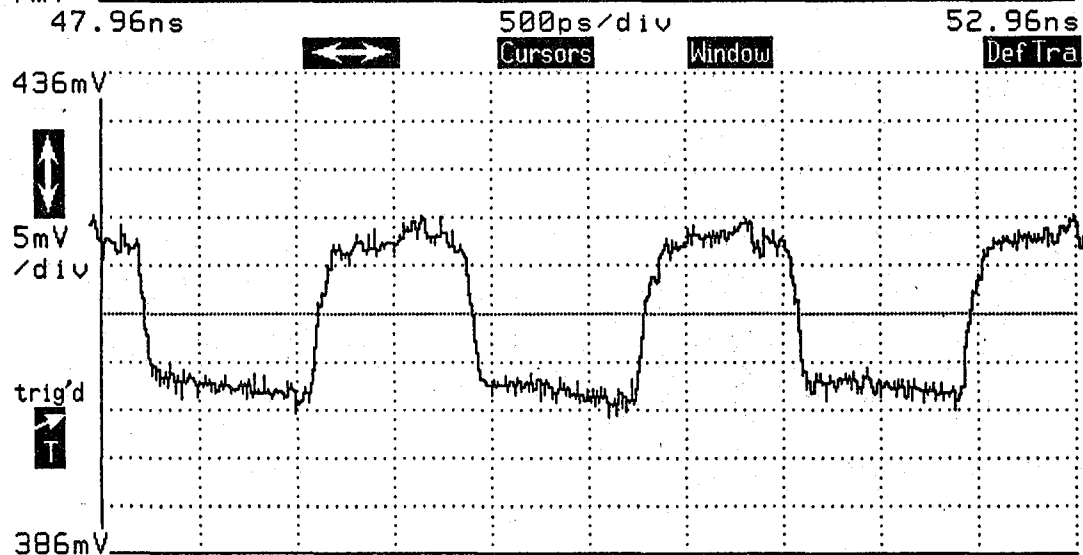
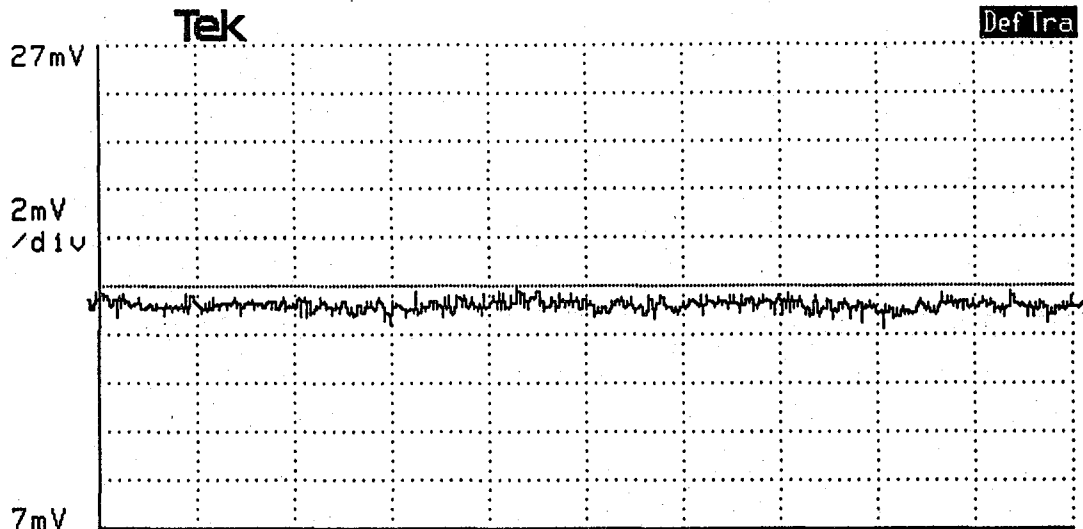

Vertical Desc	Horizontal Desc	Acquire Desc	Lower Graticule	Vert Mag: Tra
Avg (M3*25)	Main	Avg# >32	Dual	5mV/div
High Prec @	512 pts		s.V	Vert Pos: Tra
Sampling Head Fnc's	Window Mode	Save Trace Desc	More...	Remove/CirChan Trace 2 Sel
			Trace Status	Avg (M3*25) Calcd Main Tra

LASER MODULATION FABRY PEROT VOLTAGE 3.4389 V
 BASELINE NETWORK

Appendix D OTDR OBSERVATIONS OF LINKS USED IN TESTS

LINK 5-6

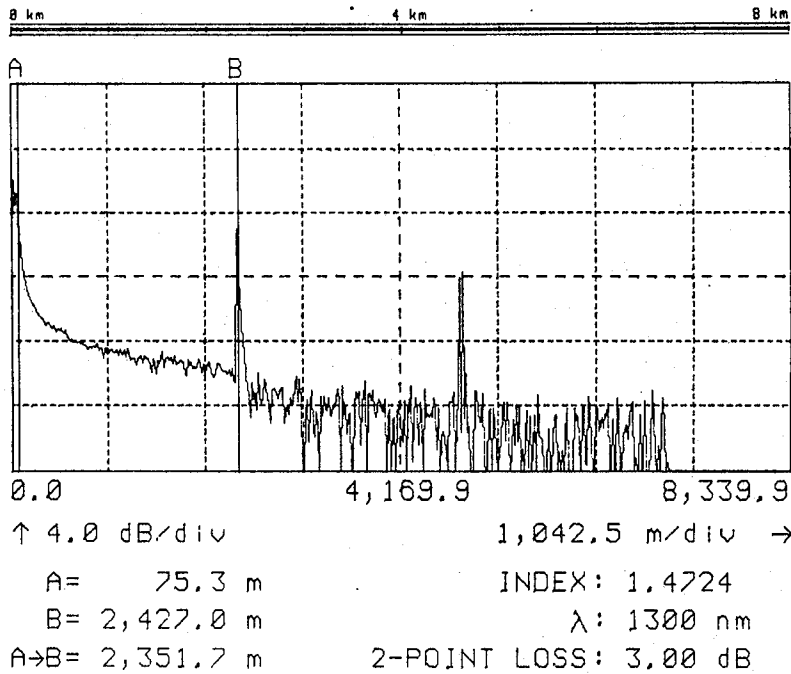

 laser precision corp. TD-9960 OTDR

Optics: TD-861 1300nm HR Multimode
 Scan Mode: INCOMPLETE
 Pulse Width: SHORT

LINK 7-8

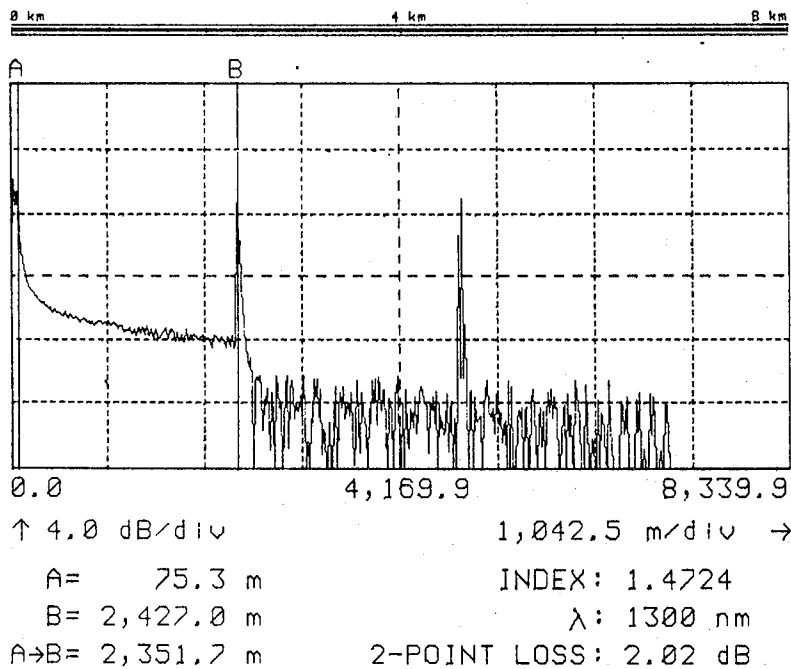

 laser precision corp. TD-9960 OTDR

Optics: TD-861 1300nm HR Multimode
 Scan Mode: INCOMPLETE
 Pulse Width: SHORT

OPTICAL TIME DOMAIN REFLECTOMETRY ON FIBER TEST LINKS USED

LAB FIBER SPOOL

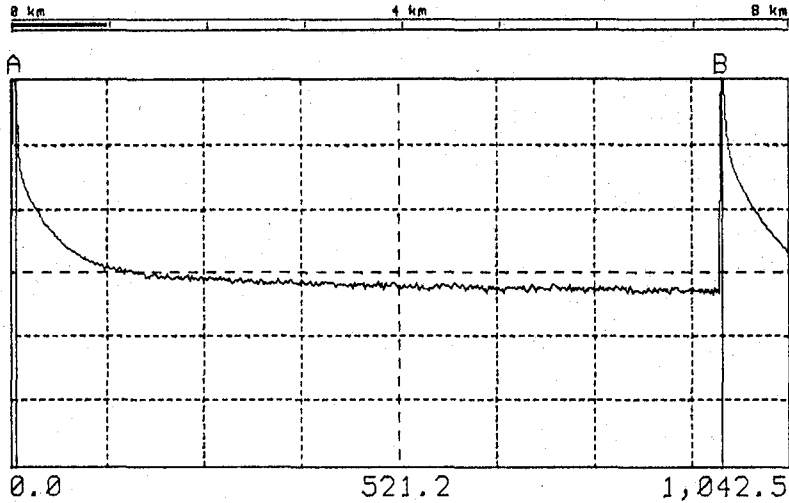

↑ 4.0 dB/div 130.3 m/div →
 A= 6.1 m INDEX: 1.4724
 B= 952.9 m λ: 1300 nm
 A→B= 946.8 m dB/km LOSS: 0.00 dB



laser precision corp.

TD-9960 OTDR

Optics: TD-861 1300nm HR Multimode
 Scan Mode: FAST
 Pulse Width: SHORT

OPTICAL TIME DOMAIN REFLECTOMETRY ON FIBER TEST LINKS USED