

# N92-15083

## INDUSTRIAL CODE DEVELOPMENT

W. Shapiro  
Mechanical Technology Inc.

The industrial codes will consist of modules of 2-D and simplified 3-D or 1-D codes, intended for expeditious parametric studies, analysis and design of a wide variety of seals. Integration into a unified system is accomplished by the industrial KBS, which will also provide User Friendly interaction, contact sensitive and hypertext help, design guidance and an expandable database.

Major seal types include Cylindrical Seals and Face Seals, and within each type are a wide variety of configurations. For example, cylindrical seals include uniform, step, taper, hydrostatic, segmented, damping, labyrinth, and spiral-groove configurations. More advanced types include brush seals, electro-fluids seals and smart seals.

The types of analyses to be included with the industrial codes are interfacial performance (leakage, load, stiffness, friction losses, etc.), thermoelastic distortions, and dynamic response to rotor excursions.

The first three codes to be completed and which are presently being incorporated into the KBS are the compressible spiral-groove codes, SPIRALG, the incompressible cylindrical code, ICYL, and the compressible cylindrical code, GCYL.

The spiral-groove codes analyzes both shaft seals and face seals with finite eccentricity and misalignment. Four degrees of freedom are included for cylindrical seals, and three for face seals. The code predicts load, flow, power loss, and cross-coupled dynamic spring and damping coefficients, shaft displacements and minimum film thickness.

The ICYL (Incompressible Cylindrical Code) is a 2-D isoviscous code that includes roughness, multiple geometries (steps, pockets, tapers, preloaded axes, and hydrostatic), turbulence, cavitation, and inertia at inlets to the film. Included are eccentricity and misalignment and variable grid specifications. Specified pressure and periodic boundary conditions can be applied. It produces pressures, flows, load, righting moments, film thickness, power loss and cross-coupled dynamic spring and damping coefficients.

GCYL is a gas cylindrical code that can treat varying geometries (steps, tapers, hydrostatic, lobed, segmented). Shaft eccentricity, misalignment, specified boundary pressures or periodic boundary conditions can be applied. The program produces the clearance distribution, pressure distribution, leakage, load, moments, power loss and cross-coupled dynamic spring and damping coefficients.

**Objectives:**

- **Compile and generate sets of verified 2D and simplified 3D or 1D codes**
  - **Codes are intended for expeditious parametric studies, analysis and design of a wide variety of seals**
  - **Integration is accomplished by the Industrial KBS.**
- Additional functions of the KBS are:**

- **User Friendly Interaction**
- **Contact Sensitive and Hypertext Help**
- **Design Guidance**
- **Expandable Database**

**SEAL TYPES - COMPRESSIBLE OR INCOMPRESSIBLE**

**Bushing and Ring Seals**

- **Uniform**
- **Axial Step**
- **Axial Taper**
- **Hydrodynamic Step**
- **Hydrodynamic Taper**
- **Self-Energized Hydrostatic**
- **Segmented**
- **Damping Seals**
- **Spiral Groove**

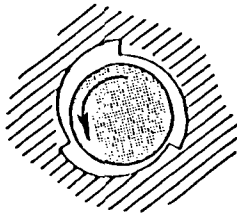

**Circumferential Multilobe**

(with or without grooves)

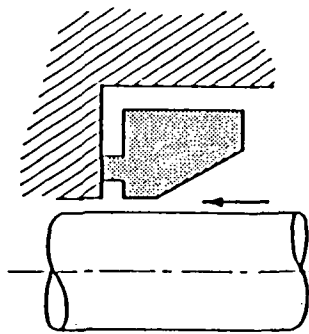

**Tapered In Flow Direction**

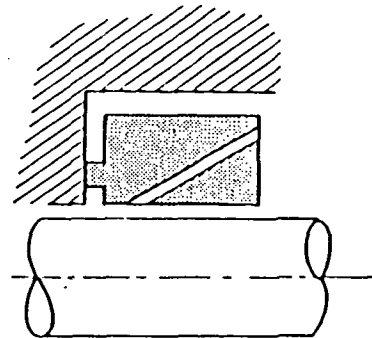

**Self-Energized — Hydrostatic**

(Inherent Compensation  
Orifice Compensation  
Spot Orifices  
Recesses)

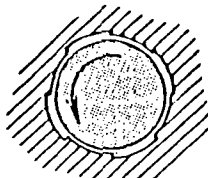

**Circumferential Rayleigh Step**

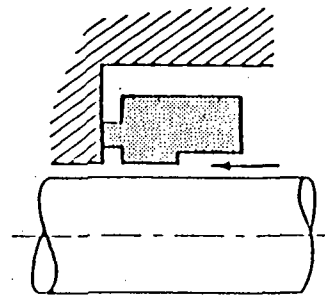

**Rayleigh Step In Direction of Flow**

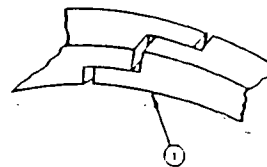
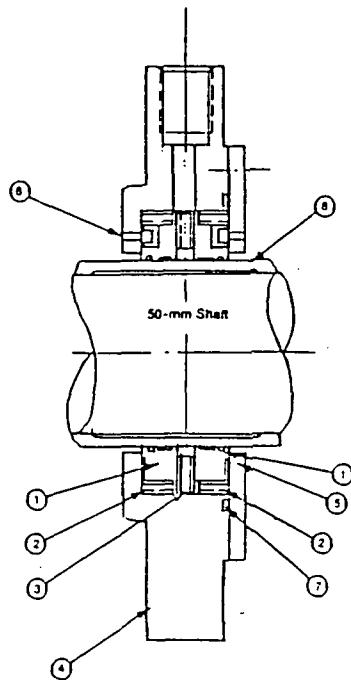

Item	Description	Material
1	Segmented Ring Rayleigh Step	Carbon
2	Spring-Radial	Inconel X-750
3	Spring-Axial	Inconel X-750
4	Housing	Stainless Steel 17-4 PH
5	Cover	Stainless Steel 17-4 PH
6	Stop Pin	Stainless Steel 17-4 PH
7	Seal	Teflon
8	Sleeve	Inconel 718 Hard Chromium Plated

SEGMENTED RING SEAL

ORIGINAL PAGE IS  
OF POOR QUALITY

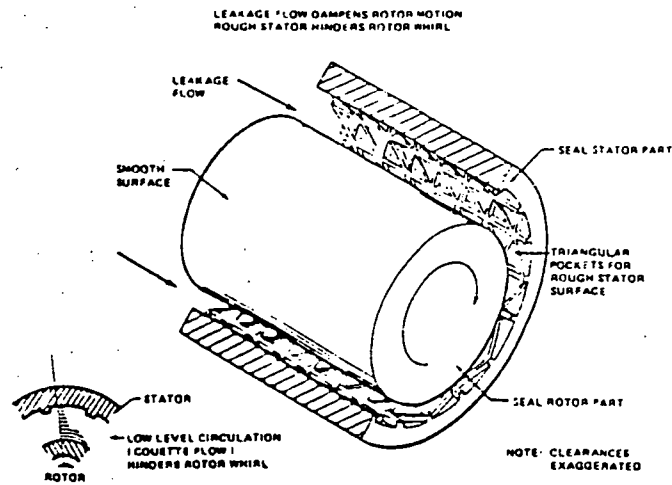

DAMPING SEAL-LEAKAGE FLOW DAMPENS ROTOR MOTION;  
ROUGH STATOR HINDERS ROTOR WHIRL

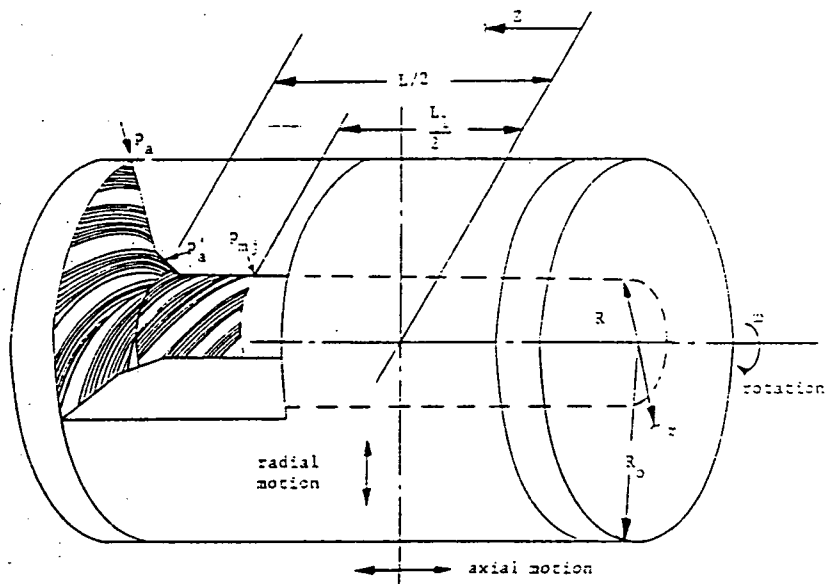

SPIRAL-GROOVE

SEAL TYPES - COMPRESSIBLE OR INCOMPRESSIBLE

Face Seals

- Contact Face Seals
- Radial Step
- Radial Taper
- Hydrodynamic Step
- Hydrodynamic Taper
- Hydrostatic
- Spiral Groove
- Multi-pad

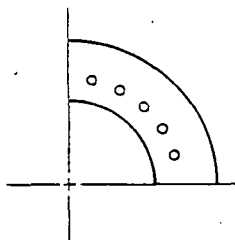

Hydrostatic

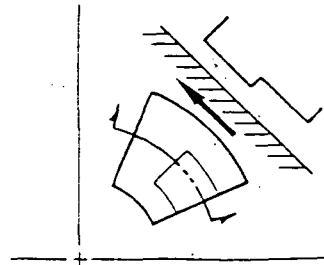

Circumferential Rayleigh Step

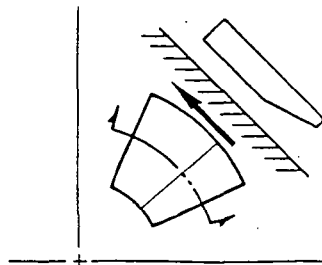

Circumferential Tapered Land

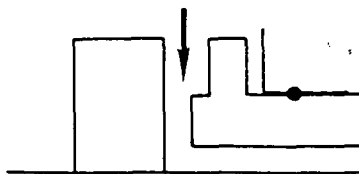

Radial Rayleigh Step

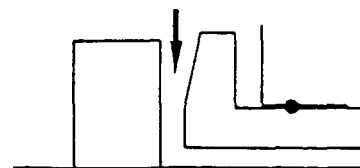

Radial Tapered Land

GFACE Configurations

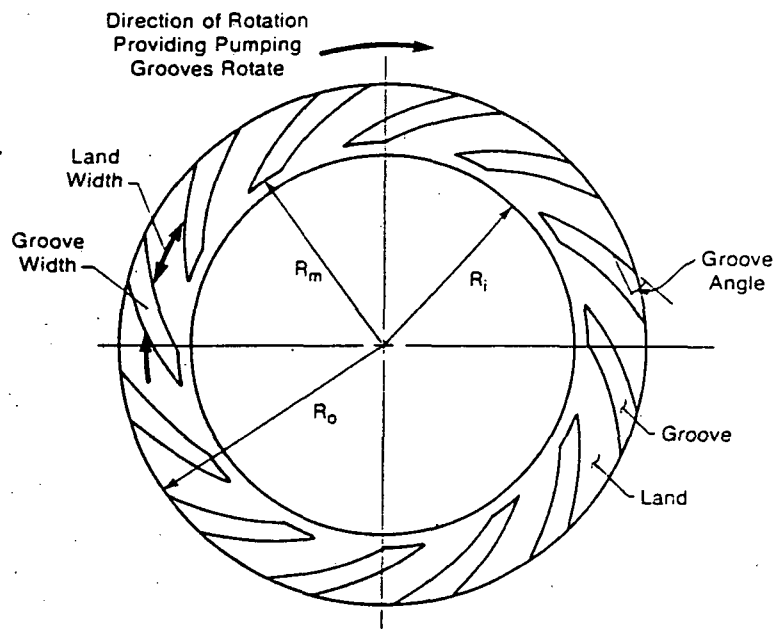

Groove Angle =  $\alpha$   
 Groove Depth = GD  
 Land Width/Groove Width =  $\gamma$

**SPIRAL GROOVE PARAMETERS**

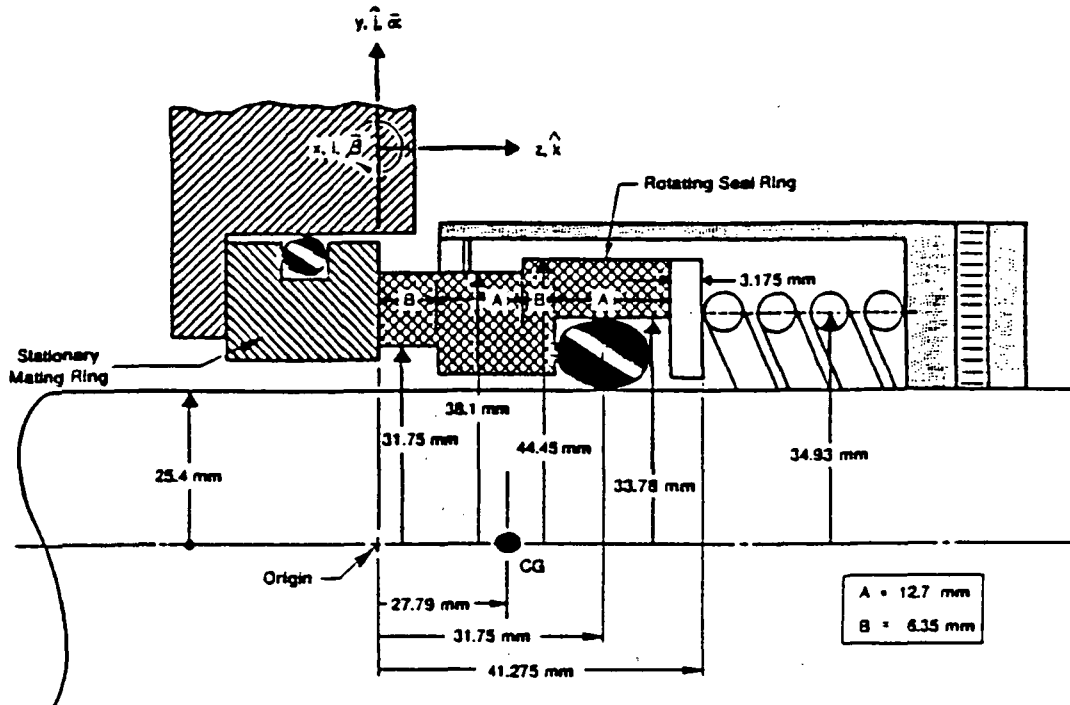

831853-1

CONTACT FACE SEAL WITH ROTATING SEAL RING

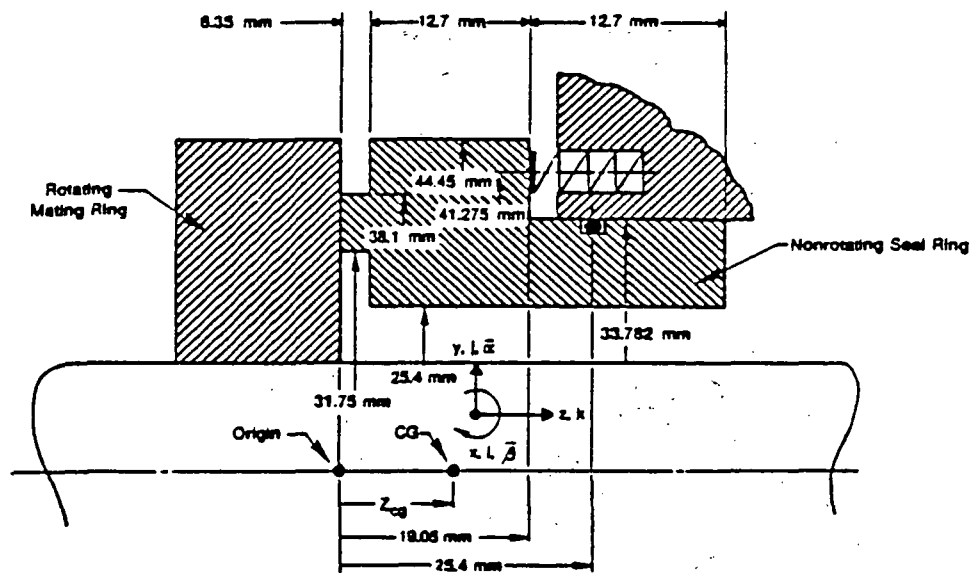

831834-1

CONTACT FACE SEAL WITH NON-ROTATING SEAL RING

(Dimensions in mm Unless Otherwise Noted)

### Brush Seals

### Labyrinth Seals

- Straight
- Stepped
- Abradable
- Angled

### Electro-Fluids Seals

### Smart Seals

### Effect of Bristle Overhang

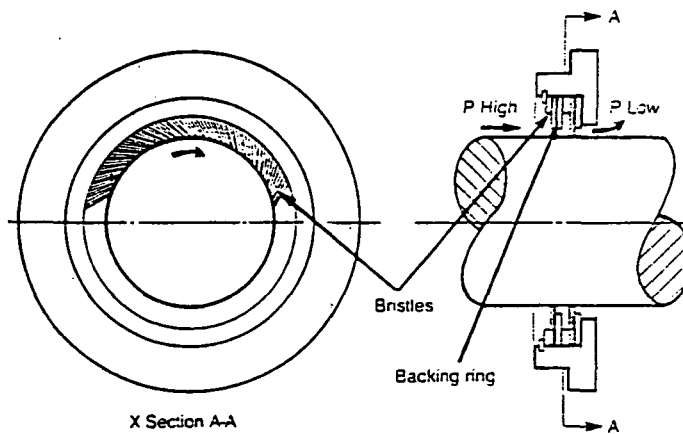
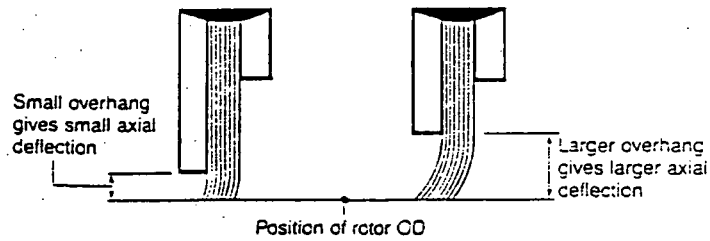
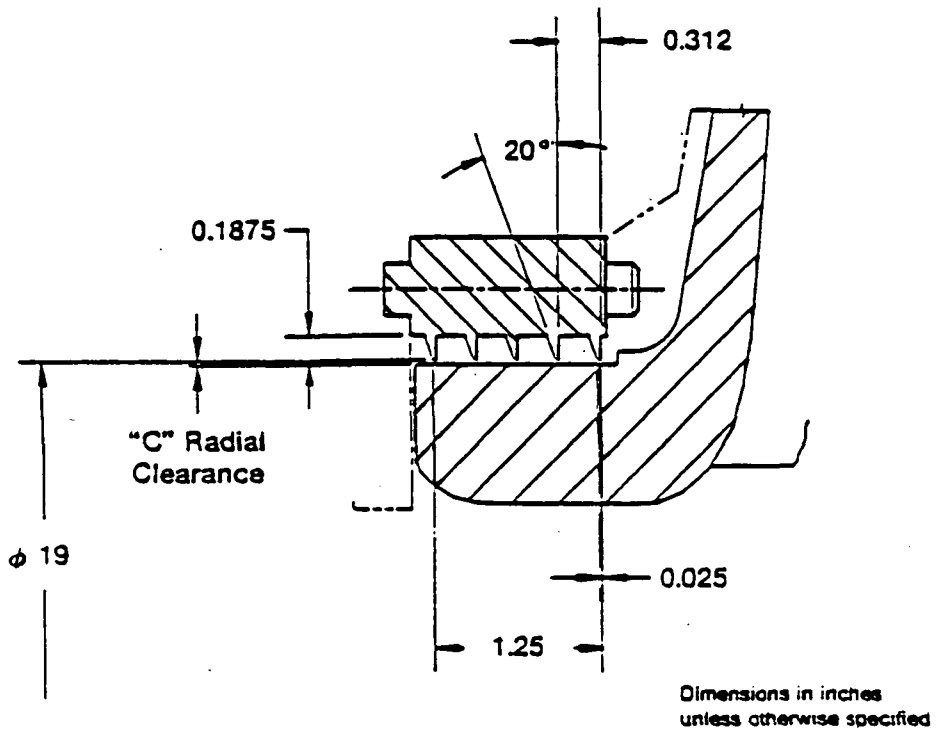

DIAGRAM SHOWING TYPICAL BRUSH SEAL ARRANGEMENT





881815

ORIGINAL INLET SEAL

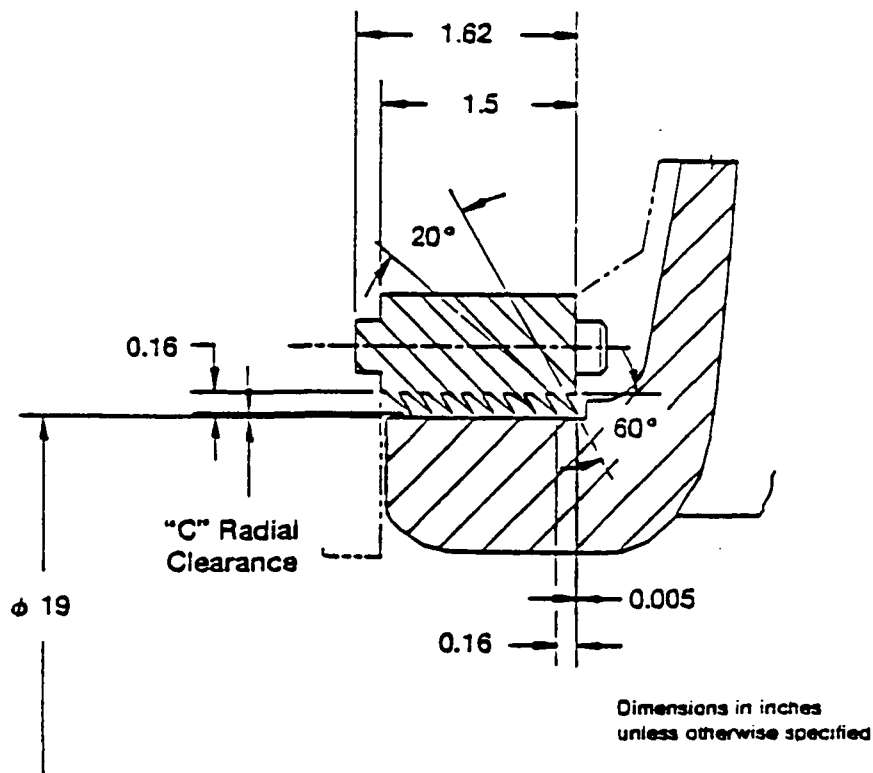

881816

OPTIMIZED STRAIGHT INLET SEAL

MAGNETIC FLUID SEAL

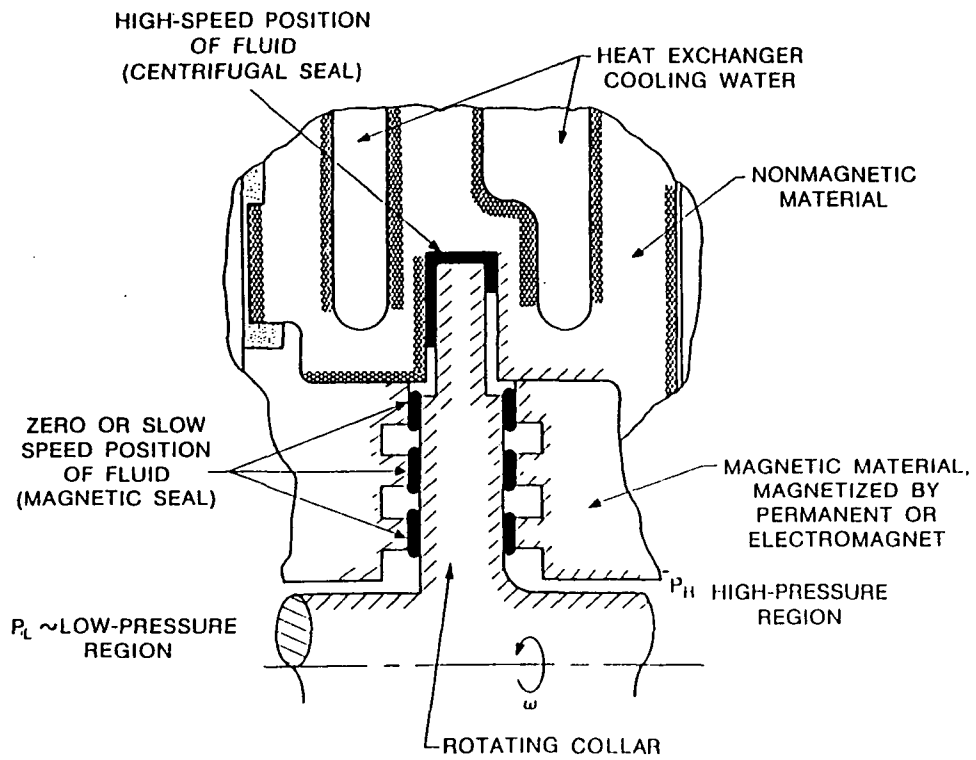

FUNDAMENTAL SEAL CONFIGURATION

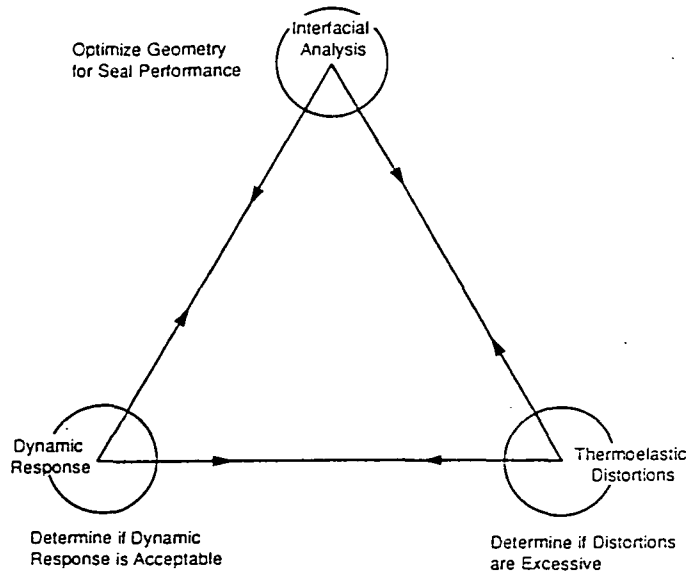

ANALYTICAL TRIAD

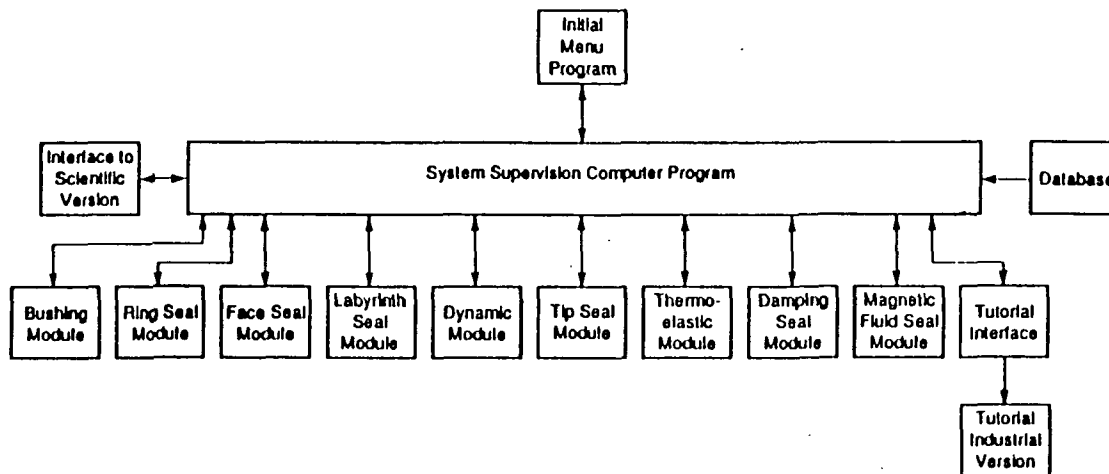

### Code Deliverables

<u>Code Module</u>	<u>Approximate Delivery Date</u>
GCYL (Gas Cylindrical)	02/01/91 ←
ICYL (Incompressible Cylindrical)	03/01/91 ←
SPIRALG (Gas Spiral Groove)	04/01/91 ←
CFD Cylindrical Code	02/01/92
IFACE (Incompressible Face)	02/01/92
GFACE (Gas Face)	03/01/92
SPIRALI (Incompressible-Spiral Groove)	04/01/92
FACEDY (Face-Dynamics)	02/01/93
RINGDY (Ring-Dynamics)	03/01/93
LABYRINTH (Gas)	04/01/93
Augmented CFD Cylindrical Module	02/01/94
FACECON (Face Contact)	02/01/94
DISTORTION (Thermo Elastic Distortion)	04/01/94
Additional Codes	04/01/95
• Brush	
• Damping Seal	
CFD Code, Face, Wave, Groove Module	09/01/95
Industrial KBS	04/01/96 ←
Scientific KBS	04/01/96
CFD, Tip, Contact, Non-Continuous Module	09/01/96

#### PLANNED ACTIVITY

- **Code unification and completion**
  - Unified Grid Generator
  - On-line Help
  
- **Code documentation**
  - Consistent with KBS usage
  
- **Additional problems and checkout**
  
- **Annual report**