

ENGINEERING DATA COMPENDIUM

Human Perception and Performance

VOLUME I

)

)

)

)

ENGINEERING DATA COMPENDIUM

Human Perception and Performance

VOLUME I

Edited by

Kenneth R. Boff

*Human Engineering Division
Armstrong Aerospace Medical Research Laboratory*

Janet E. Lincoln

University of Dayton Research Institute

Harry G. Armstrong Aerospace Medical Research Laboratory
Wright-Patterson Air Force Base, Ohio, 1988

Integrated Perceptual Information for Designers Program



NASA



AGARD

Further information on the Compendium may be obtained from:

Human Engineering Division
Harry G. Armstrong Aerospace Medical Research Laboratory
Wright-Patterson Air Force Base, OH 45433

Companion volume to the *Engineering Data Compendium*:

Handbook of Perception and Human Performance, edited by
K.R. Boff, L. Kaufman, and J.P. Thomas (New York: John
Wiley and Sons, 1986). Volumes I and II.

Library of Congress Cataloging in Publication Data:

Engineering data compendium.

Includes bibliographies and indexes.

1. Human engineering—Tables. 2. Perception—
Testing—Tables. 3. Performance—Testing—Tables.
I. Boff, Kenneth R. II. Lincoln, Janet E.

TA166.E54 1988 620.8'2 87-19560

“Engineers have been aware of the desirability of designing equipment to meet the requirements of the human operator, but in most cases have lacked the scientific data necessary for accomplishing this aim.”

In honored memory of
PAUL M. FITTS

We dedicate this work to the past and future achievements
of the organization he founded
The Human Engineering Division
Armstrong Aerospace Medical Research Laboratory

Technical Staff

Editorial

Anita Cochran
Senior Copy Editor
Director, Quality Control
Stevie Hardy
Copy Editor
University of Dayton
Research Institute

Barbara Palmer
Senior Technical Editor
Martha Gordon
Technical Editor
MacAulay-Brown, Inc.
Dayton, OH

Herschel Self
Visual Sciences Editor
User's Guide Development
Armstrong Aerospace Medical
Research Laboratory

Patrick Hess
Bill Harper
Kirsten Means
Assistant Copy Editors
University of Dayton
Research Institute

Special Projects

Edward A. Martin
Engineering Technical Advisor
Air Force Deputy for
Engineering

Jeffrey A. Landis
Senior Technical Auditor,
Glossary Development
User's Guide Development
Michele Gilkison
Permissions
University of Dayton
Research Institute

Mark Jones
Document Auditor
General Support
Maggie Hewitt
Peer Review Coordinator
Figure Drafting Auditor
MacAulay-Brown, Inc.
Dayton, OH

John Spravka
Technical Auditor
MacAulay-Brown, Inc.
Dayton, OH

Management

Karen Pettus
Anita Cochran
Project/Staff
University of Dayton
Research Institute

Gian Cacioppo
Project/Staff
MacAulay-Brown, Inc.
Dayton, OH

Judy Williams
Kathy Martin
Patricia Browne
Compendium Development
MacAulay-Brown, Inc.
Dayton, OH

Chuck Semple
Project/Staff
Essex Corp.
Los Angeles, CA

Design

Dale Fox
Director of Design
Systems Research Laboratories
Dayton, OH

Bethann Thompson
Project Designer
Systems Research Laboratories
Dayton, OH

Ken Miracle
Cover Art
Systems Research Laboratories
Dayton, OH

Dana Breidenbach
Entry Design
Graphic Design Works
Yellow Springs, OH

Drafting, Composition, and Production

Systems Research Laboratories
Dayton, OH
Composition Management & Typesetting
Bethann Thompson
Graphic Artist
Cynthia Poto
Photography
Clarence Randall, Jr.
O'Neil & Associates
Dayton, OH
Figures & Illustrations
Chuck Good
Steve Mikel
Henry Bowman

University of Dayton Research Institute
Figures & Illustrations
Fred Davis
Reinhold Strnat
Kanith Stone
Margaret Plattenburg
David Levitan
Joseph Deady
Essex Corp.
San Diego, CA
Figure Drafting
Dave Pigeon
McBee Binders
Cincinnati, OH
Binder Production Management
Robert Kellough

Harlan Typographic
Dayton, OH
Entry Composition & Typesetting
Ed Bratka
Harry Blacker
Suanne Lang
Scott Bratka
Jeff Murray
Lou Sena Aldridge
Larry Campbell
Dottie Moore
Bruce Brown
Ron Easterday
Paul Fugate
Jim Redick

Kramer Graphics, Inc.
Dayton, OH
Table Composition & Typesetting
Anthony Ashland
Monica Gorman
Sara Mitchell
Kim Perry
Andrea Snell
Ed Szymczak
Kelly Kramer
Specialised Printing Services, Limited
London, England
Printing
Derek Smith
Mike Richards

Administrative Support

MacAulay-Brown, Inc.
Dayton, OH
Word Processing
Pamela Coleman
Terry Hieber
Bernice Stewart
Sandra Suttles
Michelle Warren

Armstrong Aerospace Medical Research Laboratory
Secretarial Assistance
Tanya Ellifritt
Logistics Control
Al Chapin

University of Dayton Research Institute
Administrative Assistance
Jean Scheer

Pendragon Press
Stuyvesant, NY
Secretarial Assistance
Janine Vetter

Contributors

Section 1.0 Visual Acquisition of Information

Aries Ardit

New York Association for the
Blind and New York University

Richard S. Babb

Rockefeller University

Bernard C. Beins

Thomas More College

Randolph G. Bias

Bell Laboratories, NJ

Harry E. Blanchard

University of Illinois

Jeffrey Connell

New York University

Thomas R. Corwin

New England College of
Optometry

Steven R. Doehrman

Consultant

Claudia G. Farber

AT&T Communications, NJ

Jane Goodman

University of Washington, WA

Edward J. Hass

Franklin & Marshall College

S.M. Luria

Naval Submarine Medical

Research Laboratory, CT

William Maguire

St. John's University

Barbara Mates

American Diagnostic Learning
& Reading Center, NY

Barbara Moore

Consultant

David Post

Armstrong Aerospace Medical

Research Laboratory, Wright-

Patterson AFB, OH

Paul H. Schulman

State University of New York,

Utica

Robert Schumer

New York University

Herschel Self

Armstrong Aerospace Medical
Research Laboratory, Wright-

Patterson AFB, OH

Larry S. Solanch

Consultant

Terry J. Spencer

AT&T Information Systems,

NJ

Philip Tolin

Central Washington University

Angelo P. Verdi

Consultant

J. W. Whitlow

Rutgers University

Section 2.0 Auditory Acquisition of Information

Audrey Fullerton

Scripps College

William Maguire

St. John's University

James W. McDaniel

California State University

Vivien C. Tartter

Rutgers University

Philip Tolin

Central Washington University

Section 3.0 Acquisition of Information by Other Senses

Stuart Appelle

State University of New York,
Brockport

Richard S. Babb

Rockefeller University

Roger W. Cholewiak

Princeton University

Francis J. Clark

University of Nebraska College
of Medicine

Barbara Richardson

New York University

Carl E. Sherrick

Princeton University

Section 4.0 Information Storage and Retrieval

Steven J. Freimark

Polytechnic Institute of
New York

Edward J. Hass

Franklin & Marshall College

William Maguire

St. John's University

Vivien C. Tartter

Rutgers University

J. W. Whitlow

Rutgers University

Section 5.0 Spatial Awareness

Stuart Appelle

State University of New York,
Brockport

Aries Ardit

New York Association for the
Blind and New York University

Richard S. Babb

Rockefeller University

Randolph G. Bias

Bell Laboratories, NJ

Harry E. Blanchard

University of Illinois

Jeffrey Connell

New York University

Steven R. Doehrman

Consultant

Claudia G. Farber

AT&T Communications, NJ

Steven J. Freimark

Polytechnic Institute of
New York, NY

Audrey Fullerton

Scripps College

Edward J. Hass

Franklin & Marshall College

Robert S. Kennedy

Essex Corporation, FL

S.M. Luria

Naval Submarine Medical

Research Laboratory, CT

William Maguire

St. John's University

James W. Miller

Woodell Enterprises, Inc., FL

Barbara Moore

Consultant

Barbara Richardson

New York University

Robert Schumer

New York University

Herschel Self

Armstrong Aerospace Medical

Research Laboratory, Wright-

Patterson AFB, OH

Larry S. Solanch

Consultant

Vivien C. Tartter

Rutgers University

Robert B. Welch

University of Kansas

J. W. Whitlow

Rutgers University

Section 6.0 Perceptual Organization

Stuart Appelle

State University of New York,
Brockport

Aries Ardit

New York Association for the
Blind and New York University

Bernard C. Beins

Thomas More College

Steven J. Freimark

Polytechnic Institute of
New York

Edward J. Hass

Franklin & Marshall College

William Maguire

St. John's University

Barbara Richardson

New York University

J. W. Whitlow

Rutgers University

Section 7.0 Attention and Allocation of Resources

Andrew Ackerman
I-Math Associates, FL
Bernard C. Beins
Thomas More College
Kevin S. Berbaum
University of Iowa
Steven R. Doehrman
Consultant
William P. Dunlap
Tulane University

Edward J. Hass
Franklin & Marshall College
Robert S. Kennedy
Essex Corporation, FL
Moira LeMay
Montclair State College, NJ
Judith H. Lind
Naval Post Graduate School,
CA
S.M. Luria
Naval Submarine Medical
Research Laboratory, CT

James C. May
Louisiana State University
David Meister
U.S. Navy Personnel Research
and Development Center, CA
James W. Miller
Woodell Enterprises, Inc., FL
Barbara Moore
Consultant
Barbara Richardson
New York University

Vivien C. Tartter
Rutgers University
Angelo P. Verdi
Consultant
J. W. Whitlow
Rutgers University
Mary Williams
University of New Orleans

Section 8.0 Human Language Processing

Thomas H. Carr
Michigan State University
Daryle Jean Gardner
Kearney State College, NE

Phyllis Kossak
St. Vincent's Hospital, NY
William Maguire
St. John's University

Ethel Matin
Long Island University
Barbara Richardson
New York University

Terry J. Spencer
AT&T Information Systems,
NJ
Vivien C. Tartter
Rutgers University

Section 9.0 Operator Motor Control

Stuart Appelle
State University of New York,
Brockport
Steven Braddon
Sacred Heart University, CT

Steven R. Doehrman
Consultant
Moira LeMay
Montclair State College, NJ

Edward A. Martin
Air Force Deputy for
Engineering, Wright-Patterson
AFB, OH
Barbara Richardson
New York University

Larry S. Solanch
Consultant
J. W. Whitlow
Rutgers University

Section 10.0 Effects of Environmental Stressors

Colin Corbridge
Institute of Sound Vibration
Research, University of
Southampton, England
Thomas E. Fairley
Institute of Sound Vibration
Research, University of
Southampton, England
Jane Goodman
University of Washington

Michael J. Griffin
Institute of Sound Vibration
Research, University of
Southampton, England
Anthony Lawther
Institute of Sound Vibration
Research, University of
Southampton, England
Christopher H. Lewis
Institute of Sound Vibration
Research, University of
Southampton, England

S.M. Luria
Naval Submarine Medical
Research Laboratory, CT
William Maguire
St. John's University
Ronald McLeod
Institute of Sound Vibration
Research, University of
Southampton, England
Merrick J. Moseley
Institute of Sound Vibration
Research, University of
Southampton, England

Barbara Richardson
New York University
Herschel Self
Armstrong Aerospace Medical
Research Laboratory, Wright-
Patterson AFB, OH
Vivien C. Tartter
Rutgers University
Maxwell J. Wells
Institute of Sound Vibration
Research, University of
Southampton, England

Section 11.0 Display Interfaces

Kevin Bracken
Essex Corporation, PA
Stuart K. Card
Xerox Corporation, CA
Walter E. Carrel
Consultant
Michael M. Danchak
The Hartford Graduate Center,
CT
Steven R. Doehrman
Consultant
Claudia G. Farber
AT&T Communications, NJ

Oliver K. Hansen
HEDCON, Inc., CA
Robert Herrick
Consultant
Lloyd Hitchcock
Essex Corporation, VA
John Lazo
Essex Corporation, PA
S.M. Luria
Naval Submarine Medical
Research Laboratory, CT
Michael E. McCauley
Monterey Technologies, Inc.,
CA

Daniel E. McCrobie
General Dynamics Corporation,
CA
David Meister
Navy Personnel Research and
Development Center, CA
Thomas P. Moran
Xerox Corporation, FL
Barbara Richardson
New York University
Clarence A. Semple
Northrop Corporation, CA
Brian E. Shaw
Essex Corporation, CA

Louis D. Silverstein
Sperry Corporation, AZ
Carol Stuart-Buttle
Essex Corporation, PA
J. W. Whitlow
Rutgers University, NJ
Earl L. Wiener
University of Miami, FL
Beverly H. Williges
Virginia Polytechnic Institute
and State University, VA

Section 12.0 Control Interfaces (Real/Virtual)

Robert G. Kinkade
Essex Corporation, CA

Fredrick A. Muckler
Essex Corporation, CA

Mark Sanders
California State University,
Northridge

John A. Zich
McDonnell Douglas
Corporation, CA

Contents for Volume I

Foreword	<i>xi</i>
Preface and Acknowledgments	<i>xiii</i>
Credits for Volume I	<i>xix</i>
Introduction	<i>xxxi</i>

Section 1.0 Visual Acquisition of Information

1.1 Measurement of Light	<i>1</i>
1.2 Optics of the Eye	<i>33</i>
1.3 Sensitivity to Light	<i>117</i>
1.4 Adaptation: Changes in Sensitivity	<i>137</i>
1.5 Sensitivity to Temporal Variations	<i>165</i>
1.6 Spatial Sensitivity	<i>193</i>
1.7 Color Vision	<i>323</i>
1.8 Binocular Vision	<i>391</i>
1.9 Eye Movements	<i>421</i>

Section 2.0 Auditory Acquisition of Information

2.1 Measurement of Sound	<i>554</i>
2.2 Physiology of the Ear	<i>568</i>
2.3 Detection	<i>572</i>
2.4 Discrimination	<i>612</i>
2.5 Temporal Resolution	<i>614</i>
2.6 Loudness	<i>622</i>
2.7 Pitch	<i>650</i>
2.8 Localization	<i>672</i>

Section 3.0 Acquisition of Information by Other Senses

3.1 Cutaneous Sensitivity	<i>712</i>
3.2 Vestibular Sensitivity	<i>766</i>
3.3 Kinesthesia	<i>788</i>

)

)

)

)

Foreword

As a result of his experience in the United States Army Air Force during World War II, Dr. Paul M. Fitts fully comprehended the need for the translation of human engineering design criteria and data into a form readily accessible to the design team. He appreciated the complexity of the typical crew interface design problem, in terms of the multiple technologies involved, the interdisciplinary skills required of the design team, and the many compromises necessary to achieve a practical solution to a complex design issue. This belief in the value of concise, reliable human performance data for practical application by designers was reflected in his approach to applied problems throughout his professional career. This concern for enhancing the value of basic technology to aid the solution of practical problems has continued to influence the organization responsible for the development of this *Engineering Data Compendium* and thus it represents an extension of Paul Fitts' conviction that a well-designed crew interface significantly contributes to the safety and effectiveness of the system in which it is incorporated.

This *Engineering Data Compendium* is the second in a series of tools aimed at providing the data necessary for the human engineering design of crew systems. The first was the two-volume *Handbook of Perception and Human Performance*, edited by K. Boff, L. Kaufman, and J. Thomas and published by John Wiley and Sons, New York, in 1986. The Handbook contains an extensive treatment of the basic data on perception and performance designed for use by the human engineering specialist. It can be considered the primary reference for the Compendium.

Although necessarily limited in scope, e.g., physical anthropology is not treated, the Compendium provides in-depth treatment of human perception and performance in terms of the variables that influence the human operator's ability to acquire and process information, and make effective decisions. Both subject matter experts and potential users were consulted on an unprecedented scale in the course of preparation and review of these volumes and every effort was made to ensure the practical value of the data presented. To meet this objective, the guidance and support of a variety of US federal agencies concerned with fielding complex systems were obtained throughout the development and testing of the Compendium. Potential users

were consulted on all aspects of Compendium development, including content, readability and packaging. These consultations and extensive field testing are responsible for the usability of the volumes in typical design settings. For instance, the presentation anticipates a user who, while reasonably sophisticated in the application of technical and quantitative data, may have little prior training or experience with a specific technical area of immediate interest. For this reason, details regarding statistical and methodological reliability are included. In all entries, data are presented in an easy-to-use, standardized format and re-scaled to Système International (SI) units wherever appropriate. The packaging of the individual volumes, including the binders, volume size, internal organization, composition and type design, is based on field test results and agency guidance. Careful attention was paid to data accessibility in the design of the Compendium. Data may be accessed through a detailed table of contents, as well as key word indices, glossaries, checklists keyed to specific design topics, and knowledge maps logically organized to reflect the hierarchy of topics treated.

The *Engineering Data Compendium* is packaged in four volumes—three loose-leaf volumes containing design data and a bound *User's Guide*. It is anticipated that within a given organizational element, the three data volumes can be centrally maintained, with the *User's Guide* more generally available. The three data volumes in the loose-leaf format can thus be dynamic in the sense that multiple users can share the common data base they represent.

It was the intention of the editors and the Human Engineering Division of the Armstrong Aerospace Medical Research Laboratory to produce a practical compendium of human engineering guidance in the tradition of Dr. Paul M. Fitts. These volumes are offered to the design community at large for their evaluation of our success in meeting this objective.

CHARLES BATES, JR.
Director, Human Engineering Division

)

)

)

)

Preface and Acknowledgments

Attempting to use the research literature in perception and human performance as a means for guiding tradeoffs between equipment characteristics and human performance capabilities or limitations can be a formidable task. This is due, in part, to difficulties in retrieving and interpreting specialized data from the multitude of information sources distributed widely over a variety of report media. The intent of the *Engineering Data Compendium* is to provide an alternative basis for efficient access to the research literature. It is designed as a professional desk reference for the practitioner in search of pertinent and reliable information on human perception and performance.

The worth of any secondary reference is inextricably

tied to the user's trust in the author's objectivity and expertise in selecting and interpreting the subject matter. In the design and development of the Compendium, we have made a deliberate commitment to honor this trust.

The *Engineering Data Compendium* owes its existence to the efforts, commitment and faith of an extraordinary group of individuals—extraordinary in terms of their skills, dedication, professionalism, endurance, and sheer numbers. Below, we provide an outline of the development of the Compendium so that acknowledgments to contributors may be placed within the relevant context.

Development of the Compendium

The development of the *Engineering Data Compendium* involved many iterative stages, procedures, and processes requiring control and communications on an international scale among many participants and organizations in government, industry, and academia. In addition to the formidable challenges in accessing and dealing with technical data, many hundreds of hours were spent in planning the logistics of the contracting, management and production of the Compendium. The principal stages in the development of the *Engineering Data Compendium* are briefly outlined below.

Data Consolidation

The first step in the development of the *Engineering Data Compendium* was to identify, collect, and consolidate human perception and performance data relevant to design requirements into a primary reference—the *Handbook of Perception and Human Performance*. To accomplish this task, the domains of sensation, perception, human information processing, and human performance were reviewed. Forty-five technical subareas were selected for detailed treatment on the basis of their potential value to control and information display design. A team of more than sixty recognized experts in these technical subareas was assembled to achieve this data consolidation. The Handbook was completed in December 1984 and published in two volumes by John Wiley and Sons in Spring 1986. It has served as the principle data resource in the development of this Compendium and is frequently cross-referenced as a source of useful background information and more detailed treatment of selected empirical and theoretical topics.

Data Selection and Evaluation

The selection and evaluation of data appropriate for the *Engineering Data Compendium* were accomplished through a series of structured reviews of selected data sources and the candidate items extracted from them. Specialists familiar with a given topic area first reviewed information on that topic contained in the primary data source (the Handbook or applied literature) and selected candidate data items for the Compendium. A brief proposal was prepared for each data item that specified the anticipated treatment in the final entry, including data functions, illustrations, and citations of original reference sources (journal articles, technical re-

ports, etc.). This proposal was then evaluated by at least three reviewers with expert knowledge in the subject area. Candidate data items were assessed for applicability (generalizability and usefulness for system design), representativeness (soundness and currency of the data), and overall appropriateness for the Compendium. Reviewers were free to suggest alternative or supplementary data on the specific topic, recommend different organization or treatment, or reject the proposed data item altogether as inappropriate for the *Engineering Data Compendium*.

Entry Development

Candidate data items that passed this review were assigned to selected contributors who completed the necessary research and prepared draft entries in the required format. These drafts underwent an intensive editorial and technical audit that included recursive evaluations of each entry against the original candidate entry proposals as well as the data sources on which the entries were based. Special attention was given to ensuring that details of the methodology, data analysis, and experimental results were represented accurately in the entry (and that the errors occasionally found in the original reference sources were not reproduced in the Compendium). Many entries were rewritten, combined, or eliminated during this editing stage.

Edited entries were then sent for review to subject matter experts and, wherever possible, to system designers. The entries were evaluated along three dimensions:

- (1) Relevance: Will the information be useful to the target groups, or is it of purely academic interest?
- (2) Content: Is the basic information thoroughly represented? Is it accurate and usable as presented?
- (3) Form and style: Does the entry adhere to the prescribed format? Is it written in clear and concise language?

During the course of the successive outside reviews that occurred as each data item progressed from entry proposal to final written entry, the qualifications and background of the reviewers selected shifted from expertise in the specific subject matter under review to experience with the conditions under which the information could be applied. This procedure assured that the information in the Compendium would not only be accurate and up to date but also relevant to system design needs and comprehensible to non-specialists in the field.

Prototype

In 1984, a prototype version of the Compendium was produced, both to provide suitable materials for on-going field evaluations and to serve as an interim product in sustaining the enthusiasm of the project's patient sponsors at DoD and NASA.

The prototype Compendium was comprised of two technical sections dealing with stereoscopic vision and vibration and display perception. These topic areas were developed in full to demonstrate the flexibility of the format in covering various topics as well as different categories of information (e.g., data, models, tutorials). So that the prototype would fully embody the image and feel of the final product, we designed and incorporated front matter, keyword indices, glossaries, and other organizational and packaging elements. Compilation of the prototype served as a trial by fire for IPID project team members that allowed the refinement of managerial and editorial procedures to make production of the final volumes flow more smoothly.

Final Preparation

Final preparation of the entries for publication involved interactive audits, edits, reviews and much retyping across

Acknowledgment of the Cast

It is difficult, given a project of this scope, to acknowledge appropriately the contributions and dedication of the many individuals indispensable to its success. This task is further complicated by the many different roles assumed by contributors, including fiscal support, management, and administrative and secretarial support. All of these individuals deserve considerably greater recognition for their contributions than can possibly be achieved by this acknowledgment. Without doubt, we have inadvertently omitted some individuals who made contributions; for this, we sincerely apologize.

The program was accomplished under USAF project 7184, task 26, work units 02, 03 and 06. Crucial support was provided by Colonel Donald Carter in his role as Program Manager of the program element under which this Compendium was funded. It was managed through the offices of the Visual Display Systems Branch of the Fitts Human Engineering Division of the Armstrong Aerospace Medical Research Laboratory, Wright-Patterson Air Force Base, OH. Thomas A. Furness III, Branch Chief, and Charles Bates, Jr., Division Chief, provided encouragement and moral support during the many periods of frustration inevitable in a project of this size. Most importantly, they created an environment in which novel ideas, such as the one that inspired this project, could be nurtured and sustained through final delivery of products. As the Compendium took form, Charlie orchestrated the support and marshalled the resources needed for its production and widespread distribution throughout the international human engineering community.

In the branch and the Fitts Human Engineering Division, we are indebted to many individuals for support and constructive criticism that helped define the project's conceptual basis and immeasurably improved the quality of the product. Gloria Calhoun aided much of the early planning that enabled the project to flourish. Herschel Self contributed long hours and enormous intellectual effort in the review, editing and critiquing of Compendium entries. Herschel single-handedly drafted the thousands of design-re-

multiple drafts. Quality control concerns were central to our processing of the entry manuscripts. Quantitative formulations, authors' names, and reference citations were checked and rechecked. Several thousand figures, tables, and illustrations were drafted, converted to SI (Système International) units, reviewed, proofed and corrected. Permissions for the use of copyrighted materials were sought and paid for, and the multitude of individual credit lines specified by copyright holders were inserted.

Production

To maintain control over Compendium design, product quality, and costs to the final consumer, we assumed the traditional role of publisher in managing the production, manufacturing and distribution of the Compendium. This included the complete design of the document (artwork design, type style and layout of text, binder design), type composition, proofreading of galleys and page proofs, printing and photographic work, binder manufacture and packaging. In addition, we took primary responsibility for defining the logistics for the shipping, handling, warehousing and distribution of the Compendium.

lated questions that comprise the design checklists in the *User's Guide* (Vol. IV). Robert Eggleston contributed many thoughtful suggestions and much personal energy in aiding major aspects of the project. David Post, our resident color perception expert, gave generously of his time and expertise to ensure the technical accuracy of the treatment of color vision in the Compendium. Professional contributions and peer reviews were also provided by Mark Cannon, Bill Crawford, Thomas Furness, Fran Green, Michael Haas, Steve Heckart, Gilbert Kuperman, Grant McMillan, Wayne Martin, Gary Reid, Donald Topmiller, Sharon Ward, Richard Warren, and Melvin Warrick. Al Chapin, Division Custodian, made heroic efforts to ensure that the special binder requirements for the Compendium would be met. Last, but by no means least, Barbara Osman, Executive Secretary for the Fitts Human Engineering Division, carefully proofread volumes of project correspondence. Sandy Stevenson expedited contractual matters and expertly proofread all IPID product reports. Within the Visual Display Systems Branch, Tanya Ellifritt personally gave wide-ranging administrative assistance and attention to the project.

We are also very grateful for the advocacy and support provided by Henning Von Gierke (Division Chief) and members of the technical staff of the Biodynamics and Bioengineering Division of the Armstrong Aerospace Medical Research Laboratory. These include the invaluable contributions by Tim Anderson, Jim Brinkley, Urena Erasmo, Charles Harris, Richard McKinley, Thomas Moore, Charles Nixon, Daniel Repperger, Richard Shoenberger, Mark Stephenson, Bill Welde, and Robert Van Patten.

Ken Zimmerman and Patricia Lewandowski, of the AAMRL Scientific and Technical Information Office, worked with the appropriate agency officials to clear many limited-distribution government documents for public release so that useful data from these reports could be included in the Compendium.

The idea for the project evolved from a former Air Force effort for which much inspiration is owed our colleagues Patricia Knoop, Lawrence Reed, Rick Gill, Bert Cream, Don Gum, and Gordon Eckstrand. Belief in the idea of an

Engineering Data Compendium and its potential value to the design engineering community spurred Art Doty, former Chief Engineer for the Air Force Deputy for Simulators, to agree to provide major sponsorship of this project. There is little doubt that this initial support opened the doors to subsequent multi-agency funding that supported the project and, in fact, enabled its survival. We are also grateful for the steadfast support and trust throughout the project provided by the Office of the Air Force Deputy for Training Systems (formally the Deputy for Simulators), presently under the leadership of Colonel Wayne Lobbstaël. Many useful suggestions and valuable support were rendered by the technical and administrative staffs of the Training Systems SPO. In particular, we wish to acknowledge Jim Basinger, George Dickison, Jim O'Connell (current Chief Engineer), Bob Swab, Chris Hanson, and Nancy Droz.

Special acknowledgment is due to Edward A. Martin of the Training Systems Division of the Air Force Deputy for Equipment Engineering. Ed graciously gave of his time and made significant conceptual contributions during all phases of this project. More importantly, Ed's role as Engineering Technical Advisor has been invaluable in maintaining liaison and rapport with the engineering community, thereby ensuring the relevance of the project to engineering needs. Significant suggestions and support were provided by many others of the Wright Field community, in particular, Richard Heintzman, Richard O'Dell, Jim Brown, Royce Few, Tom Kelly, and Bill Curtice.

In addition to the Armstrong Aerospace Medical Research Laboratory and the Air Force Deputy for Training Systems, agencies within each of the Armed Services and the National Aeronautics and Space Administration (NASA) provided financial and technical support. The principal individuals involved in this vital support are: Walter Chambers and Dennis Wightman of the Naval Training Systems Center, Orlando, FL (NTSC); Stan Collyer, now with Naval Systems Command, who initiated Navy participation in the project; Charles Gainer, Chief of the Army Research Institute (ARI) Field Unit at Ft. Rucker, AL; Clarence Fry of the Army Human Engineering Laboratory, Aberdeen Proving Grounds, MD; Thomas Longridge, formerly with the Air Force Human Resources Laboratory, now with ARI, Ft. Rucker; Melvin Montemerlo, NASA Headquarters, Washington, D.C.; Walter Truskowski of NASA Goddard Space Flight Center, MD; and David Nagel of NASA Ames Research Center, CA.

Particularly worthy of acknowledgment is the outstanding demonstration of support and approval for our efforts by NATO's Advisory Group for Aerospace Research and Development (AGARD) and its Technical Director, Irving C. Statler. He readily supported the recommendation of Air Commodore G.K.M. Maat, Royal Netherlands Air Force, and Colonel K. Jessen, Royal Danish Air Force, Chairman and Vice Chairman, respectively, of the Aerospace Medical Panel of AGARD, to cost-share the manufacture of this Compendium to ensure its distribution throughout the NATO countries. For expediting NATO participation in the production of the Compendium, we are further indebted to George Hart, Technical Information Panel Executive, and Majors L.B. Crowell and John Winship, Canadian Forces, Aerospace Medical Panel Executives.

The project was principally supported and staffed by the University of Dayton Research Institute (UDRI), MacAulay-Brown, Inc., and Systems Research Labora-

tories, Dayton, OH, and by the Essex Corporation, Westlake Village, CA.

The University of Dayton Research Institute (UDRI) was the principal organization providing support to the Integrated Perceptual Information for Designers (IPID) Project and was integrally involved in the development of the *Handbook of Perception and Human Performance* and this *Engineering Data Compendium*. Throughout this effort, UDRI was indispensable in maintaining the high technical and scholarly standards we set ourselves. Indeed, the contributions of UDRI to achieving the goals of this project went far beyond their contractual obligations. In particular, we are grateful for the benevolent oversight of George Nolan, Director of the Research Institute, and the zealous and protective IPID project management by Karen Pettus. Not only was Karen an outstanding program manager, but she took unusual personal pride in and responsibility for the work at each and every step of the project.

UDRI also played the lead role in quality control, copyediting, copyright permissions and development of the *User's Guide*, among myriad other technical processing functions. Aided by student cadre, Anita Cochran managed and personally shouldered much of the responsibility for accomplishing these functions. Anita has been a very special person to all of us on this project. Her commitment to excellence and her everpresent sense of humor are appreciated beyond our ability to express in this acknowledgment. Stevie Hardy, Associate Copy Editor, made significant contributions to entry style and took primary responsibility for defining the binding and packaging options for the Compendium. Over the duration of this project, dozens of UD students supported this effort in part-time employment. Several, in particular, endured and contributed in significant ways. Jeff Landis assumed a great deal of personal responsibility for ensuring the accuracy and quality of many component elements of the Compendium. Michele Gilkison, among other tasks, personally directed the massive job of soliciting, recording, and auditing thousands of permissions for the use of copyrighted materials in the Compendium. Patrick Hess, Bill Harper, Kirsten Means, and Larry Sauer all had important influence on the quality of this work. Many of the figures in the Compendium were drafted with the help of UD student aides. These included Dennis Weatherby, Allen Baradora, Stephen Cook, Andrew Dejaco, Catherine Fuchs, Russell Velego, Jolene Boutin, Denise McCollum, and Julie Gerdeman. Much of the secretarial and administrative burden of the project at UDRI was efficiently shouldered in a good-natured manner by Jean Scheer.

After the bulk of the entries were written, MacAulay-Brown, Inc., assumed the lead role in managing technical editing, auditing, peer review, figure drafting, and clerical functions, as well as a range of other tasks critical to the technical credibility of the work. In addition, many informal contributions were made by members of the technical staff of MacAulay-Brown. A great deal is owed to the impressive personnel direction and program management of Gian Cacioppo. Gian single-handedly built the MacAulay-Brown team machine that got the job done. No less critical was the day-to-day detailed management of entry processing accomplished by Judy Williams, Kathy Martin, and Patricia Browne, in turn. Barbara Palmer, Senior Technical Editor, was the gatekeeper for standards of excellence and

technical accuracy at MacAulay-Brown. Martha Gordon, Associate Technical Editor, made many lasting contributions, including the detection of numerous errors in original published source materials that would otherwise have been perpetuated in the Compendium. Mark Jones, a graduate of the UD Handbook team, served loyally as a troubleshooter through much of the project. Among other tasks, he searched out the people and the means to get official public release of many DoD documents. As we began to push the time limits of the project, many members of the staff contributed to getting the job done. We are grateful for the efforts of Marie Palmer, Jan Cox, Debbie Warner, Joyce Jones, Laura Anderson, and Jeff Agnew. In addition, valuable management and administrative support was provided by John MacAulay, Aulay Carlson, Ron Loeliger, and Donna Stafford.

The Human Engineering Program Office of Systems Research Laboratories also played a major enabling role in the development and production of the Compendium. Many individuals made invaluable technical contributions to the content and design of entries, motivated by professional dedication to the quality of the product rather than mere contractual obligations. There is little doubt that the professionalism we so fortunately tapped with this effort owes much to the personal model and leadership style of Ken Bish, Manager of the HE Project Office. Diana Nelson, Human Factors Group Manager, committed much personal energy to the project both as an expert reviewer and as an administrator of the technical supporting staff. Sarah Osgood and Becky Donovan immersed themselves in the critical task of providing a quality control check of the galleys and final page proofs. We are particularly grateful for their willingness to jump into the fray and get the job done right. We are thankful for the efforts on behalf of the project by Pat Wabler (Office Manager); Sean Layne and Robert Linder (student aides); and Chuck Skinn and Joyce Sibley (Systems Research Laboratories, Biodynamics and Bio-Engineering Contract Office).

Major contributions to the final style and quality appearance of the Compendium were made by the Systems Research Laboratories Corporate Graphics/Photo Lab. Dale Fox served as Director of Design for the IPID Project, making many personal innovative contributions as well as directing the creative talents of an outstanding team of professionals. We were particularly impressed by the attention to detail, aesthetics, and excellence brought to the project by Bethann Thompson. Equally important to this project were the efforts of Cynthia Poto, Ken Miracle, and Clarence Randall, Jr.

Working under a subcontract to MacAulay-Brown, Inc., Essex Corporation (Westlake Village, CA) organized the preparation and initial technical editing of entries in a range of applied research areas (e.g., person-computer interaction) which are now distributed throughout the three volumes. Many members of the Essex technical staff contributed as writers, editors, and reviewers. In addition, the activities of a number of outside experts were orchestrated to the benefit of the Compendium. The single-minded commitment to excellence and personal integrity demonstrated by Chuck Semple, the Essex Project Manager, provided a model for all. Chuck often burned the midnight oil to meet his personal goals for this effort.

We would like to thank Professor Michael Griffin and his research team at the Institute for Sound and Vibration Research at the University of Southampton (England) for contributing the section on vibration and display perception in the Compendium prototype. This group showed an outstanding commitment to excellence and attention to detail both in meeting the stringent content and format demands and in assuring the accuracy of the presentation.

We are also indebted to Judith Lind (Naval Post-Graduate School, Monterey, CA) and Keith Shute (University of Vermont School of Medicine) for adjunct technical editing and technical support.

Janine Vetter, Susen Genc, Andrea Nevins, Rose Lee, and Francine Marranca cheerfully and efficiently handled the typing and paperwork required to maintain a smooth flow of materials to and from source reviewers and entry writers.

In addition, we are grateful for the insightful criticism, commentary, encouragement, and data review provided by the legion of interested professionals and formal reviewers who graciously gave of their time. Many individuals were solicited through intermediaries and cannot be singled out by name. Nonetheless, the goals toward which we aspired in developing the Compendium would not have been met without their contributions and support. We sincerely regret any omissions to the honor roll of contributors that follows:

Air Force Aeronautical Systems Division, Deputy for Equipment Engineering, Wright-Patterson AFB, OH.

Jack Ackerson, John Amell, Mark Adducchio, Sarkis Barsamian, Jim Blair, Capt. Rob Collins, Joel Cooper, Bill Curtice, Tony DalSasso, Gibbs Dickson, Herm Engel, Ron Ewart, Chuck Fabian, Royce Few, Art Gill, Igor Golovcsenko, Lt. Jay Horn, Richard Heintzman, Tom Hoog, Ed Hughes, Tom Hughes, Tom Kelly, Don Kittinger, Sue Kuramoto, Mary Ladd, Tim Lincourt, Ed Martin, Brian Melville, Alan Pinkus, Lt. Ed Rogers, Richard Schiffler, Lt. Greg Szafranski.

Naval Training Systems Center, Orlando, FL

Arthur Blaiwes, Denis Breglia, Steve Butrimas, Walt Chambers, Tom Galloway, Gil Ricard, Dennis Wightman.

Naval Air Development Center, Warminster, PA

William Breitmaier, David Gleisner, Thomas Hanna, Timothy Singer, Stan Winsko.

Other Agencies and Institutions

Andrew Ackerman (I-Math Associates, FL)
Christopher Arbak (McDonnell Douglas Corporation, MO)
Sara Asmussen (University of Toledo)
Greg Barbetto (Systems Research Laboratories, OH)
Jim Basinger (AF Deputy for Training Systems, WPAFB OH)
Herb Bell (AF Human Resources Lab, Williams AFB, AZ)
Richard Bernstein (Brooklyn College, CUNY)
Alvah Bittner (Naval Biodynamics Lab, LA)
Mark Brauer (Lockheed Corp., CA)

Stuart Card (Xerox Corp., Palo Alto, CA)
 Thomas Carr (Michigan State University)
 Gerald Chaiken (US Army Missile Command, Redstone Arsenal, AL)
 Paul Chatelier (Perceptronics, VA)
 Roger Cholewiak (Princeton University)
 Francis Clark (University of Nebraska Medical Center)
 Herbert Colle (Wright State University)
 J. David Cook (University of Western Ontario)
 Michael Danchak (The Hartford Graduate Center, CT)
 Frank Dapolito (University of Dayton)
 George Davidson (New York University)
 Diana Deutsch (University of California, San Diego)
 Ron Erickson (Naval Weapons Center, CA)
 Thomas Eggemeier (University of Dayton)
 Arye Ephrath (Bell Communications Research)
 Richard Farrell (Boeing Aerospace, WA)
 Lawrence Feth (University of Kansas)
 John Flach (University of Illinois, Champaign-Urbana)
 Marcia Finkelstein (University of South Florida)
 Beth Fischer (New York University)
 George Gescheider (Hamilton College)
 Peter Grigg (University of Massachusetts Medical Center)
 Genevieve Haddad (Office of the Air Force Surgeon General)
 Stephen Hall (NASA, Marshall Space Flight Center, AL)
 Peter Hallett (University of Toronto)
 Harold Hawkins (Office of Naval Research)
 Marcia Hayes (Consultant)
 Robert Hennessy (Monterey Technologies, Monterey, CA)
 Sala Horowitz (Consultant)
 Ian Howard (York University, Canada)
 Peter Jusczyk (University of Oregon)
 Lloyd Kaufman (New York University)
 John Keselica (Fairleigh Dickinson University)
 Robert Kinkade (Essex Corporation, CA)
 Gary Klein (Klein Associates, OH)
 Gerald Krueger (Walter Reed Army Institute of Research)
 John Lacey (Consultant)
 Norman Lane (Essex Corporation, FL)
 Peter Lennie (University of Rochester)
 Judith Lind (Naval Postgraduate School)
 Mike Loeb (University of Louisville)
 Tom Longridge (Army Research Institute, Ft. Rucker, AL)
 Jim McCracken (MacAulay-Brown, Inc., OH)
 Daniel McCrobie (General Dynamics Corp., CA)
 Dan McGuire (AF Human Resources Laboratory, Williams AFB, AZ)
 Elizabeth Martin (AF Human Resources Laboratory, Williams AFB, AZ)
 Ethel Matin (C. W. Post Center, Long Island University)
 Leonard Matin (Columbia University)
 David Meister (Navy Personnel Research and Development Center, CA)
 Steve Merriman (McDonnell Douglas Corp., MO)
 John Merritt (Interactive Technologies, VA)
 Margaret Mitchell (Pennsylvania State University)
 Kirt Moffitt (Anacapa Sciences)
 Thomas Moran (Xerox Corp, CA)
 Frederick Muckler (Essex Corporation, CA)
 Robert Mulligan (Rutgers University)
 Donna Neff (Boy's Town Institute for Communication Disorders)
 Diana Nelson (Systems Research Laboratories, OH)
 Mike Nelson (Nelson Associates, OH)
 Richard O'Dell (AF Deputy for Training Systems, WPAFB OH)
 John O'Hare (Office of Naval Research)
 Lynn Olzak (University of California; Los Angeles)
 Jesse Orlansky (Institute for Defense Analysis)
 Dan Parker (Miami University)
 Gena Pedroni (University of West Florida)
 Joel Pokorny (University of Chicago)
 Norman Potter (Systems Research Laboratories, OH)
 Robert Pulliam (Martin Marietta Corp., CO)
 Julian Puretz (University of Wisconsin, Parkside)
 David Quam (MacAulay-Brown, Inc., OH)
 Evan Rolek (Systems Research Laboratories, OH)
 Emilie Rappoport (Consultant)
 Thomas Sanquist (ADAC Laboratories)
 Hal Sedgwick (SUNY College of Optometry)
 Clarence Semple (Northrop Corp., CA)
 Wayne Shebilske (Texas A&M University)
 Carl Sherrick (Princeton University)
 Clark Shingledecker (NTI, Inc., OH)
 Lou Silverstein (Sperry Corp., AZ)
 Helen Sing (Walter Reed Army Institute of Research)
 Vivianne Smith (University of Chicago)
 George Sperling (New York University)
 James Staszewski (Carnegie Mellon University)
 Jim Thomas (University of California, Los Angeles)
 Andrea Thompson (Consultant)
 David Thorne (Walter Reed Army Institute of Research)
 Frank Ward (Wright State University)
 Joel Warm (University of Cincinnati)
 David Warren (University of California, Riverside)
 Dan Weber (Wright State University)
 Robert Welch (University of Kansas)
 Mary Vanderwart Wetzel (Consultant)
 Chris Wickens (University of Illinois Institute of Aviation)
 Pat Widder (AF Human Resources Laboratory, Williams AFB, AZ)
 Earl Wiener (University of Miami)
 Lowell Williams (MacAulay-Brown, Inc., OH)
 Beverly Williges (Virginia Polytechnic Institute)
 Steven Zecker (Colgate University)
 John Zich (McDonnell Douglas Corp., CA)

Our sincere thanks are also offered to the many publishers and authors who gave us permission to reprint the figures and illustrations in the Compendium.

Over the extended period of development of this Compendium, we received many helpful suggestions, insights, and encouragement when they were most needed. Conrad Kraft, Richard Farrell, John Booth, and Wolf Hebenstreit of the Boeing Aerospace Co. (Seattle, WA) were a source of early stimulation and ideas that had significant influence on the development of the Compendium. John Sinacori stimulated our creative spirits; Bill Rouse broadened our intellectual perspective on the problem; Gary Klein stimulated our thinking and helped sharpen our faculties for self-criticism; Harold Van Cott, Earl Alluisi and Julian Christensen each

provided timely reinforcement of our sense of the worth of what we were attempting to accomplish; Genevieve Haddad provided ardent support and many insightful suggestions; Bob Hennessy shared an intellectual camaraderie on the problem of applying basic research findings to system design.

Finally, this project incurred great sacrifice on the part of those closest to us. Two children—Cory Asher Boff and Kyra Melissa Boff—were born and have substantially grown in the course of the IPID project. Our spouses, Judy

Boff and Bob Kessler, have tolerated, beyond reasonable limits, our zealous preoccupation with completing this project without compromise to our standards and ideals.

KENNETH R. BOFF
*Armstrong Aerospace Medical Research Laboratory
Wright-Patterson Air Force Base, Ohio*

JANET E. LINCOLN
*University of Dayton Research Institute
Dayton, Ohio, and Stuyvesant, New York*

Credits for Volume I

- 1.102, Fig. 1: From S. T. Henderson, *Daylight and its spectrum* (2nd ed.). Copyright © 1977 by Adam Hilger Ltd. Reprinted with permission.
- 1.103, Fig. 2: From J. G. Beebe-Center, L. Carmichael, & L. C. Mead, Daylight training of pilots for night flying, *Aeronautical Engineering Review*, 1944, 3. Reprinted with permission.
- 1.103, Fig. 3: From J. G. Beebe-Center, L. Carmichael, & L. C. Mead, Daylight training of pilots for night flying, *Aeronautical Engineering Review*, 1944, 3. Reprinted with permission.
- 1.104, Fig. 1: From J. Pokorny, V. C. Smith, G. Verriest, & A. J. L. G. Pinckers, *Congenital and acquired color defects*, Grune & Stratton, 1979. Reprinted with permission.
- 1.104, Fig. 2: From J. Pokorny, V. C. Smith, G. Verriest, & A. J. L. G. Pinckers, *Congenital and acquired color defects*, Grune & Stratton, 1979. Reprinted with permission.
- 1.105, Fig. 1: From *Design handbook for imagery interpretation equipment* by R. J. Farrell & J. M. Booth, Document D180-19063-1, Boeing Aerospace Co., Seattle, WA, 1975.
- 1.106, Fig. 1: From *Design handbook for imagery interpretation equipment* by R. J. Farrell & J. M. Booth, Document D180-19063-1, Boeing Aerospace Co., Seattle, WA, 1975.
- 1.106, Fig. 2: From *Design handbook for imagery interpretation equipment* by R. J. Farrell & J. M. Booth, Document D180-19063-1, Boeing Aerospace Co., Seattle, WA, 1975.
- 1.106, Fig. 3: From *Design handbook for imagery interpretation equipment* by R. J. Farrell & J. M. Booth, Document D180-19063-1, Boeing Aerospace Co., Seattle, WA, 1975.
- 1.106, Fig. 4: From *Design handbook for imagery interpretation equipment* by R. J. Farrell & J. M. Booth, Document D180-19063-1, Boeing Aerospace Co., Seattle, WA, 1975.
- 1.107, Fig. 1: From J. Pokorny & V. C. Smith, Color vision, in A. M. Potts (Ed.), *The assessment of visual function*. Reproduced by permission of Albert M. Potts.
- 1.107, Fig. 2: From J. Pokorny & V. C. Smith, Colorimetry and color discrimination, in K. R. Boff, L. Kaufman, & J. P. Thomas (Eds.), *Handbook of perception and human performance: Volume I. Sensory processes and perception*. Copyright © 1986 by John Wiley & Sons, Inc. Reprinted with permission.
- 1.107, Tab. 1: From J. Pokorny & V. C. Smith, Colorimetry and color discrimination, in K. R. Boff, L. Kaufman, & J. P. Thomas (Eds.), *Handbook of perception and human performance: Volume I. Sensory processes and perception*. Copyright © 1986 by John Wiley & Sons, Inc. Reprinted with permission.
- 1.109, Fig. 1: From G. Wagner & R. M. Boynton, Comparison of four methods of heterochromatic photometry, *Journal of the Optical Society of America*, 1972, 62. Reprinted with permission.
- 1.109, Tab. 2: From J. Pokorny & V. C. Smith, Colorimetry and color discrimination, in K. R. Boff, L. Kaufman, & J. P. Thomas (Eds.), *Handbook of perception and human performance: Volume I. Sensory processes and perception*. Copyright © 1986 by John Wiley & Sons, Inc. Reprinted with permission.
- 1.110, Fig. 2: From J. Pokorny & V. C. Smith, Colorimetry and color discrimination, in K. R. Boff, L. Kaufman, & J. P. Thomas (Eds.), *Handbook of perception and human performance: Volume I. Sensory processes and perception*. Copyright © 1986 by John Wiley & Sons, Inc. Reprinted with permission.
- 1.111, Fig. 1: From W. S. Stiles & B. H. Crawford, The luminous efficiency of rays entering the eye pupil at different points, *Proceedings of the Royal Society of London*, 1933, B112. Reprinted with permission.
- 1.111, Fig. 2: From G. Westheimer, The eye as an optical instrument, in K. R. Boff, L. Kaufman, & J. P. Thomas (Eds.), *Handbook of perception and human performance: Volume I. Sensory processes and perception*. Copyright © 1986 by John Wiley & Sons, Inc. Reprinted with permission.
- 1.111, Fig. 3: From D. H. Jacobs, The Stiles-Crawford effect and the design of telescopes, *Journal of the Optical Society of America*, 1944, 34. Reprinted with permission.
- 1.201, Fig. 1: From J. L. Brown, The structure of the visual system, in C. H. Graham (Ed.), *Vision and visual perception*. Copyright © 1966 by John Wiley & Sons, Inc. Reprinted with permission.
- 1.202, Fig. 1: From W. T. Ham, H. A. Mueller, & J. J. Ruffolo, Retinal effects of blue light exposure, *Ocular effects of non-ionizing radiation*, 1980, SPIE 229. Reprinted with permission.
- 1.202, Fig. 2: From G. Wyszecki & W. S. Stiles, *Color science* (2nd ed.), Copyright © 1982 by John Wiley & Sons, Inc. Reprinted with permission.
- 1.202, Tab. 1: From S. S. Stevens, *Handbook of experimental psychology*. Copyright © 1966 by John Wiley & Sons, Inc. Reprinted with permission.
- 1.203, Fig. 1: From *Design handbook for imagery interpretation equipment*, R. J. Farrell & J. M. Booth, Document D180-19063-1, Seattle, WA, 1975.
- 1.204, Fig. 1: From G. M. Wyburn, R. W. Pickford, & R. J. Hirst, in G. M. Wyburn (Ed.), *Human senses and perception*, Oliver & Boyd, 1964. Reprinted with permission.
- 1.205, Fig. 1: From T. N. Cornsweet, *Visual perception*, Academic Press, 1970.
- 1.205, Fig. 2: From G. Westheimer, The eye as an optical instrument, in K. R. Boff, L. Kaufman, & J. P. Thomas (Eds.), *Handbook of perception and human performance: Volume I. Sensory processes and perception*. Copyright 1986 © by John Wiley & Sons, Inc. Reprinted with permission.
- 1.206, Fig. 1: From G. Westheimer, The eye as an optical instrument, in K. R. Boff, L. Kaufman, & J. P. Thomas (Eds.), *Handbook of perception and human performance: Volume I. Sensory processes and perception*. Copyright © 1986 by John Wiley & Sons, Inc. Reprinted with permission.
- 1.207, Fig. 1: From *Design handbook for imagery interpretation equipment*, by R. J. Farrell & J. M. Booth, Document D180-19063-1, Boeing Aerospace Co., Seattle, WA, 1975.
- 1.207, Fig. 2: From I. J. Spiro, Eye location for a wide-field large-exit-pupil optical system, *Journal of the Optical Society of America*, 1961, 51. Reprinted with permission.
- 1.208, Fig. 1: From *Design handbook for imagery interpretation equipment*, R. J. Farrell & J. M. Booth, Document D180-19063-1, Boeing Aerospace Co., Seattle, WA, 1975.
- 1.209, Fig. 1: From *Design handbook for imagery interpretation equipment*, R. J. Farrell & J. M. Booth, Document D180-19063-1, Boeing Aerospace Co., Seattle, WA, 1975.
- 1.209, Fig. 2: From *Design handbook for imagery interpretation equipment*, R. J. Farrell & J. M. Booth, Document D180-19063-1, Boeing Aerospace Co., Seattle, WA, 1975.
- 1.209, Fig. 3: From *Handbook for imagery interpretation equipment*, R. J. Farrell & J. M. Booth, Document D180-19063-1, Boeing Aerospace Co., Seattle, WA, 1975.
- 1.209, Fig. 4: From A. G. Bennett & J. L. Francis, The eye as an optical system, in H. Davson (Ed.), *The eye: Visual optics and optical space sense*. Copyright © 1962 by Academic Press. Reprinted with permission.
- 1.210, Tab. 1: From G. Westheimer, The eye, in V. B. Mountcastle (Ed.), *Medical physiology*, C. V. Mosby & Co., 1968.
- 1.212, Fig. 1: From C. H. Graham (Ed.), *Vision and visual perception*. Copyright © 1965 by John Wiley & Sons, Inc. Reprinted with permission.
- 1.213, Fig. 1: From T. N. Cornsweet, *Visual perception*. Copyright 1970. Reprinted by permission of Harcourt Brace Jovanovich.
- 1.213, Fig. 2: From G. Westheimer, The eye as an optical instrument, in K. R. Boff, L. Kaufman, & J. P. Thomas (Eds.), *Handbook of perception and human performance: Volume I. Sensory processes and perception*. Copyright © 1986 by John Wiley & Sons, Inc. Reprinted with permission.
- 1.213, Tab. 2: From G. Westheimer, The eye as an optical instrument, in K. R. Boff, L. Kaufman, & J. P. Thomas (Eds.), *Handbook of perception and human performance: Volume I. Sensory processes and perception*. Copyright © 1986 by John Wiley & Sons, Inc. Reprinted with permission.
- 1.214, Fig. 1: From G. Westheimer, The eye as an optical instrument, in K. R. Boff, L. Kaufman, & J. P. Thomas (Eds.), *Handbook of perception and human performance: Volume I. Sensory processes and perception*. Copyright © 1986 by John Wiley & Sons, Inc. Reprinted with permission.
- 1.214, Fig. 2: From G. Westheimer, The spatial sense of the eye, *Investigative Ophthalmology and Visual Science*, 1979, 18. Reprinted with permission.

- 1.214, Tab. 1: From G. Westheimer, The eye as an optical instrument, in K. R. Boff, L. Kaufman, & J. P. Thomas (Eds.), *Handbook of perception and human performance: Volume 1. Sensory processes and perception*. Copyright © 1986 by John Wiley & Sons, Inc. Reprinted with permission.
- 1.215, Fig. 1: From G. Westheimer, The eye as an optical instrument, in K. R. Boff, L. Kaufman, & J. P. Thomas (Eds.), *Handbook of perception and human performance: Volume 1. Sensory processes and perception*. Copyright © 1986 by John Wiley & Sons, Inc. Reprinted with permission.
- 1.215, Fig. 2: From G. Westheimer, The eye as an optical instrument, in K. R. Boff, L. Kaufman, & J. P. Thomas (Eds.), *Handbook of perception and human performance: Volume 1. Sensory processes and perception*. Copyright © 1986 by John Wiley & Sons, Inc. Reprinted with permission.
- 1.216, Fig. 1: Reprinted with permission from *Vision Research*, 21, J. A. M. Jennings & W. N. Charman, Off-axis quality in the human eye, copyright © 1981, Pergamon Press Ltd.
- 1.217, Tab. 1: From H. Hartridge, The visual perception of fine detail, *Philosophical Transactions*, 1947, B232. Reprinted with permission.
- 1.218, Fig. 1: From G. Westheimer, The eye as an optical instrument, in K. R. Boff, L. Kaufman, & J. P. Thomas (Eds.), *Handbook of perception and human performance: Volume 1. Sensory processes and perception*. Copyright © 1986 by John Wiley & Sons, Inc. Reprinted with permission.
- 1.219, Fig. 1: From G. Westheimer, The eye as an optical instrument, in K. R. Boff, L. Kaufman, & J. P. Thomas (Eds.), *Handbook of perception and human performance: Volume 1. Sensory processes and perception*. Copyright © 1986 by John Wiley & Sons, Inc. Reprinted with permission.
- 1.219, Tab. 1: From G. Westheimer, The eye as an optical instrument, in K. R. Boff, L. Kaufman, & J. P. Thomas (Eds.), *Handbook of perception and human performance: Volume 1. Sensory processes and perception*. Copyright © 1986 by John Wiley & Sons, Inc. Reprinted with permission.
- 1.220, Fig. 1: From G. Westheimer & S. P. McKee, Stereoscopic acuity with defocused and spatially filtered retinal images, *Journal of the Optical Society of America*, 1980, 70. Reprinted with permission.
- 1.221, Fig. 1: From G. Westheimer, The eye as an optical instrument, in K. R. Boff, L. Kaufman, & J. P. Thomas (Eds.), *Handbook of perception and human performance: Volume 1. Sensory processes and perception*. Copyright © 1986 by John Wiley & Sons, Inc. Reprinted with permission.
- 1.221, Fig. 2: From T. N. Cornsweet, *Visual perception*. Copyright © 1970 by Academic Press. Reprinted with permission.
- 1.222, Fig. 1: From *Design handbook for imagery interpretation equipment*, by R. J. Farrell & J. M. Booth, Document D180-19063-1, Seattle, WA, 1975.
- 1.222, Fig. 2: From G. Westheimer, The eye as an optical instrument, in K. R. Boff, L. Kaufman, & J. P. Thomas (Eds.), *Handbook of perception and human performance: Volume 1. Sensory processes and perception*. Copyright © 1986 by John Wiley & Sons, Inc. Reprinted with permission.
- 1.222, Fig. 3: From G. Westheimer, The eye as an optical instrument, in K. R. Boff, L. Kaufman, & J. P. Thomas (Eds.), *Handbook of perception and human performance: Volume 1. Sensory processes and perception*. Copyright © 1986 by John Wiley & Sons, Inc. Reprinted with permission.
- 1.223, Fig. 1: From H. W. Leibowitz & D. A. Owens, Anomalous myopias and the intermediate dark focus of accommodation, *Science*, 189. Copyright 1975 by the American Association for the Advancement of Science.
- 1.225, Fig. 1: From F. W. Campbell, Correlation of accommodation between the two eyes, *Journal of the Optical Society of America*, 1960, 50. Reprinted with permission.
- 1.226, Fig. 1: From G. Westheimer, The eye as an optical instrument, in K. R. Boff, L. Kaufman, & J. P. Thomas (Eds.), *Handbook of perception and human performance: Volume 1. Sensory processes and perception*. Copyright © 1986 by John Wiley & Sons, Inc. Reprinted with permission.
- 1.226, Fig. 2: Reprinted with permission from *Vision Research*, 20, D. A. Owens, A comparison of accommodative responsiveness and contrast sensitivity for sinusoidal gratings, copyright © 1980, Pergamon Press Ltd.
- 1.227, Fig. 1: From M. Koomen, R. Scolnik, & R. Tousey, A study of night myopia, *Journal of the Optical Society of America*, 1951, 41. Reprinted with permission.
- 1.228, Fig. 1: From C. A. Johnson, Effects of luminance and stimulus distance on accommodation and visual resolution, *Journal of the Optical Society of America*, 1976, 66(2). Reprinted with permission.
- 1.229, Fig. 1: From *Design handbook for imagery interpretation equipment* by R. J. Farrell & J. M. Booth, Document D180-19063-1, Boeing Aerospace Co., Seattle, WA, 1975.
- 1.229, Fig. 2: From *Design handbook for imagery interpretation equipment* by R. J. Farrell & J. M. Booth, Document D180-19063-1, Boeing Aerospace Co., Seattle, WA, 1975.
- 1.230, Fig. 1: (a) From G. J. van der Wildt & M. A. Bouman, An accommodationeter: An apparatus for measuring the total accommodation response to the human eye, *Applied Optics*, 1971, 10. (b) From H. Krueger, An apparatus for continuous, objective measurement of refraction of the human eye, *Optica Acta*, 1973, 20, as shown in Figure 3.8-14 of *Design handbook for imagery interpretation equipment* by R. J. Farrell & J. M. Booth, Document D180-19063-1, Boeing Aerospace, Seattle, WA, 1975.
- 1.231, Fig. 1: Reprinted by permission: D. D. Michaels, *Visual optics and refraction* (2nd ed.), St. Louis, 1975, The C. V. Mosby Co., Latest ed. 1985.
- 1.233, Fig. 1: Reprinted with permission from *Vision Research*, 6, J. Mellerio, Ocular refraction at low illuminations, copyright © 1966, Pergamon Press Ltd.
- 1.233, Fig. 2: From J. Hornung, Pupillenbewegungen nach einem Sprung der Reizlichtintensitat (Pupillary movements after a jump in the intensity of the stimulus light), *Pflugers Archiv*, 1967, 296. Reprinted with permission.
- 1.233, Fig. 3: (a) From G. Westheimer, The eye as an optical instrument, in K. R. Boff, L. Kaufman, & J. P. Thomas (Eds.), *Handbook of perception and human performance: Volume 1. Sensory processes and perception*. Copyright © 1986 by John Wiley & Sons, Inc. Reprinted with permission. (b) From P. Reeves, Rate of pupillary dilation and contraction, *Psychological Review*, 1918, 25. Reprinted with permission.
- 1.234, Fig. 1: From *Design handbook for imagery interpretation equipment*, R. J. Farrell & J. M. Booth, Document D180-19063-1, Boeing Aerospace Co., Seattle, WA, 1984.
- 1.235, Fig. 2: From data in I. M. Borish, *Clinical refraction*, as shown in Figure 3.5-7 of *Design handbook for imagery interpretation equipment*, R. J. Farrell & J. M. Booth, Boeing Aerospace Co., Seattle, WA, 1975.
- 1.236, Fig. 1: From A. Burg, Lateral visual field as related to age and sex, *Journal of Applied Psychology*, 52. Copyright © 1968 by the American Psychological Association. Reprinted with permission of the author.
- 1.238, Fig. 1: From G. Westheimer, The eye as an optical instrument, in K. R. Boff, L. Kaufman, & J. P. Thomas (Eds.), *Handbook of perception and human performance: Volume 1. Sensory processes and perception*. Copyright © 1986 by John Wiley & Sons, Inc. Reprinted with permission.
- 1.240, Tab. 1: From G. Westheimer, The eye as an optical instrument, in K. R. Boff, L. Kaufman, & J. P. Thomas (Eds.), *Handbook of perception and human performance: Volume 1. Sensory processes and perception*. Copyright © 1986 by John Wiley & Sons, Inc. Reprinted with permission.
- 1.301, Tab. 1: From *Experimental psychology*, 3rd ed., by J. W. Kling & L. A. Riggs. Copyright © 1938, 1954, 1971 by Holt, Rinehart & Winston, Inc. Reprinted with permission.
- 1.301, Fig. 1: From J. W. Kling & L. A. Riggs (Eds.), *Woodworth and Schlosberg's experimental psychology* (3rd ed.). Copyright © 1972 by Holt, Rinehart & Winston.
- 1.301, Fig. 2: From J. W. Kling & L. A. Riggs (Eds.), *Woodworth and Schlosberg's experimental psychology* (3rd ed.). Copyright © 1972 by Holt, Rinehart & Winston.
- 1.302, Fig. 1: From D. B. Judd, Basic correlates of the visual stimulus, in S. S. Stevens (Ed.), *Handbook of experimental psychology*. Copyright © 1951 by John Wiley & Sons, Inc. Reprinted with permission.
- 1.302, Fig. 2: From D. C. Hood & M. A. Finkelstein, Sensitivity to light, in K. R. Boff, L. Kaufman, & J. P. Thomas (Eds.), *Handbook of perception and human performance: Volume 1. Sensory processes and perception*. Copyright © 1986 by John Wiley & Sons, Inc. Reprinted with permission.
- 1.303, Fig. 1: From G. Wyszecki & W. S. Stiles, *Color science* (2nd ed.). Copyright © 1982 by John Wiley & Sons, Inc. Reprinted with permission.
- 1.303, Fig. 2: From G. Wyszecki, Correlated for brightness in terms of CIE chromaticity coordinates and luminous reflectance, *Journal of the Optical Society of America*, 1967, 57. Reprinted with permission.
- 1.304, Fig. 1: From D. B. Judd, Basic correlates of the visual stimulus, in S. S. Stevens (Ed.), *Handbook of experimental psychology*. Copyright © 1951 by John Wiley & Sons, Inc. Reprinted with permission.
- 1.306, Fig. 1: From D. C. Hood & M. A. Finkelstein, Sensitivity to light, in K. R. Boff, L. Kaufman, & J. P. Thomas (Eds.), *Handbook of perception and human performance: Volume 1. Sensory processes and perception*. Copyright © 1986 by John Wiley & Sons, Inc. Reprinted with permission.
- 1.307, Fig. 1: From D. C. Hood & M. A. Finkelstein, Sensitivity to light, in K. R. Boff, L. Kaufman, & J. P. Thomas (Eds.), *Handbook of perception and human performance: Volume 1. Sensory processes and perception*. Copyright © 1986 by John Wiley & Sons, Inc. Reprinted with permission.

- 1.307, Fig. 3: Reprinted with permission from *Vision Research*, 17, A. M. W. Scholtes & M. A. Bouman, Psychophysical experiments on spatial summation at threshold level of the human peripheral retina, copyright © 1977, Pergamon Press Ltd.
- 1.308, Fig. 1: From D. C. Hood & M. A. Finkelstein, Sensitivity to light, in K. R. Boff, L. Kaufman, & J. P. Thomas (Eds.), *Handbook of perception and human performance: Volume I. Sensory processes and perception*. Copyright © 1986 by John Wiley & Sons, Inc. Reprinted with permission.
- 1.309, Fig. 3: From G. Wyszecki, Color appearance, in K. R. Boff, L. Kaufman, & J. P. Thomas (Eds.), *Handbook of perception and human performance: Volume I. Sensory processes and perception*. Copyright © 1986 by John Wiley & Sons, Inc. Reprinted with permission.
- 1.401, Fig. 1: From D. C. Hood & M. A. Finkelstein, Sensitivity to light, in K. R. Boff, L. Kaufman, & J. P. Thomas (Eds.), *Handbook of perception and human performance: Volume I. Sensory processes and perception*. Copyright © 1986 by John Wiley & Sons, Inc. Reprinted with permission.
- 1.402, Fig. 1: From *Journal of General Physiology*, 21, 635-650, 1938. Reprinted with permission of the Helen Dwight Reid Educational Foundation. Published by Heldref Publications. Copyright © 1938.
- 1.402, Fig. 2: From *Journal of General Physiology*, 21, 635-650. Reprinted with permission of the Helen Dwight Reid Educational Foundation. Published by Heldref Publications. Copyright © 1938.
- 1.403, Fig. 1: From D. C. Hood & M. A. Finkelstein, Sensitivity to light, in K. R. Boff, L. Kaufman, & J. P. Thomas (Eds.), *Handbook of perception and human performance: Volume I. Sensory processes and perception*. Copyright © 1986 by John Wiley & Sons, Inc. Reprinted with permission.
- 1.404, Fig. 1: From A. S. Patel & R. W. Jones, Incremental and decremental visual thresholds, *Journal of the Optical Society of America*, 1968, 58. Reprinted with permission.
- 1.405, Fig. 1: Reprinted with permission from *Vision Research*, 22, E. H. Adelson, Saturation and adaptation in the rod system, copyright © 1982, Pergamon Press Ltd.
- 1.405, Fig. 2: From D. C. Hood & M. A. Finkelstein, Sensitivity to light, in K. R. Boff, L. Kaufman, & J. P. Thomas (Eds.), *Handbook of perception and human performance: Volume I. Sensory processes and perception*. Copyright © 1986 by John Wiley & Sons, Inc. Reprinted with permission.
- 1.407, Fig. 1: From E. Auerbach & G. Wald, Identification of a violet receptor in human color vision, *Science*, 120. Copyright 1954 by the American Association for the Advancement of Science. Reprinted with permission.
- 1.408, Fig. 1: From *Journal of General Physiology*, 19, 321-337. Reprinted with permission from the Helen Dwight Reid Educational Foundation. Published by Heldref Publications. Copyright © 1935.
- 1.409, Fig. 1: From D. C. Hood & M. A. Finkelstein, Sensitivity to light, in K. R. Boff, L. Kaufman, & J. P. Thomas (Eds.), *Handbook of perception and human performance: Volume I. Sensory processes and perception*. Copyright © 1986 by John Wiley & Sons, Inc. Reprinted with permission.
- 1.410, Fig. 1: From J. L. Brown, C. H. Graham, H. Leibowitz, & H. B. Ranken, Luminance thresholds for the resolution of visual detail during dark adaptation, *Journal of the Optical Society of America*, 1953, 43. Reprinted with permission.
- 1.411, Fig. 1: From D. C. Hood & M. A. Finkelstein, Sensitivity to light, in K. R. Boff, L. Kaufman, & J. P. Thomas (Eds.), *Handbook of perception and human performance: Volume I. Sensory processes and perception*. Copyright © 1986 by John Wiley & Sons, Inc. Reprinted with permission.
- 1.412, Fig. 1: From M. M. Hayhoe, Lateral interactions in human cone dark adaptation, *Journal of Physiology*, 1979, 296.
- 1.413, Fig. 1: From H. D. Baker, Some direct comparisons between light and dark adaptation, *Journal of the Optical Society of America*, 1955, 45(10). Reprinted with permission.
- 1.502, Fig. 1: From A. B. Watson, Temporal sensitivity, in K. R. Boff, L. Kaufman, & J. P. Thomas (Eds.), *Handbook of perception and human performance: Volume I. Sensory processes and perception*. Copyright © 1986 by John Wiley & Sons, Inc. Reprinted with permission.
- 1.503, Fig. 1: From D. H. Kelly, Visual responses to time-dependent stimuli: I. Amplitude sensitivity measurements, *Journal of the Optical Society of America*, 1961, 51. Reprinted with permission.
- 1.504, Fig. 1: From R. J. Lythgoe & K. Tansley, The relation of the critical frequency of flicker to the adaptation of the eye, *Proceedings of the Royal Society (London)*, 1929, B105. Reprinted with permission.
- 1.505, Fig. 1: From D. H. Kelly, Theory of flicker and transient responses: II. Counterphase gratings, *Journal of the Optical Society of America*, 1971, 61(5). Reprinted with permission.
- 1.506, Fig. 1: From D. H. Kelly, Effects of sharp edges in a flickering field, *Journal of the Optical Society of America*, 1959, 49. Reprinted with permission.
- 1.507, Fig. 1: From W. C. Roehrig, The influence of area on the critical flicker-fusion threshold, *Journal of Psychology*, 1959, 47. A publication of the Helen Dwight Reid Educational Foundation. Reprinted with permission.
- 1.508, Fig. 1: From J. G. Robson, Spatial and temporal contrast sensitivity functions of the visual system, *Journal of the Optical Society of America*, 1966, 56. Reprinted with permission.
- 1.508, Fig. 2: From J. J. Koenderinck & A. J. van Doorn, Spatiotemporal contrast detection threshold surface is bimodal, *Optics Letters*, 1979, 4. Reprinted with permission.
- 1.509, Fig. 1: From J. J. Kulikowski & D. J. Tolhurst, Psychophysical evidence for sustained and transient detectors in human vision, *Journal of Physiology*, 1973, 232. Reprinted with permission.
- 1.510, Fig. 1: Reprinted with permission from *Vision Research*, 21, A. B. Watson & J. G. Robson, Discrimination at threshold: Labelled detectors in human vision, copyright © 1981, Pergamon Press Ltd.
- 1.512, Fig. 1: From H. B. Barlow, Temporal and spatial summation in human vision at different background intensities, *Journal of Physiology*, 1958, 141. Reprinted with permission.
- 1.512, Fig. 2: Reprinted with permission from *Vision Research*, 12, J. A. Roufs, Dynamic properties of vision - I. Experimental relationships between flicker and flash thresholds, copyright © 1972, Pergamon Press Ltd.
- 1.513, Fig. 1: From A. B. Watson, Temporal sensitivity, in K. R. Boff, L. Kaufman, & J. P. Thomas (Eds.), *Handbook of perception and human performance: Volume I. Sensory processes and perception*. Copyright © 1986 by John Wiley & Sons, Inc. Reprinted with permission.
- 1.513, Fig. 2: From A. B. Watson, Temporal sensitivity, in K. R. Boff, L. Kaufman, & J. P. Thomas (Eds.), *Handbook of perception and human performance: Volume I. Sensory processes and perception*. Copyright © 1986 by John Wiley & Sons, Inc. Reprinted with permission.
- 1.601, Fig. 1: From L. Olzak & J. P. Thomas, Seeing spatial patterns, in K. R. Boff, L. Kaufman, & J. P. Thomas (Eds.), *Handbook of perception and human performance: Volume I. Sensory processes and perception*. Copyright © 1986 by John Wiley & Sons, Inc. Reprinted with permission.
- 1.602, Fig. 1: From *Design handbook for imagery interpretation equipment*, by R. J. Farrell & J. M. Booth, Document D180-19063-1, Boeing Aerospace Co., 1975.
- 1.604, Fig. 1: From S. Shlaer, The relation between visual acuity and illumination, *Journal of General Physiology*, 1937, 21. A publication of the Helen Dwight Reid Educational Foundation. Reprinted with permission.
- 1.604, Fig. 2: From L. Olzak & J. P. Thomas, Seeing spatial patterns, in K. R. Boff, L. Kaufman, & J. P. Thomas (Eds.), *Handbook of perception and human performance: Volume I. Sensory processes and perception*. Copyright © 1986 by John Wiley & Sons, Inc. Reprinted with permission.
- 1.605, Fig. 1: From S. H. Bartley, *Vision: A study of its basis*, Van Nostrand Reinhold, 1941.
- 1.606, Fig. 1: From S. Shlaer, E. L. Smith, & A. M. Chase, Visual acuity and illumination in different spectral regions, *Journal of General Physiology*, 25, 553-569, as shown in figure 3.2-40 of *Design handbook for imagery interpretation equipment*, R. J. Farrell & J. M. Booth, Document D180-19063-1, Boeing Aerospace, Seattle, WA, 1975.
- 1.607, Fig. 1: (a) From G. Westheimer, K. Shimamura, & S. P. McKee, Interference with line-orientation sensitivity, *Journal of the Optical Society of America*, 1976, 66. Reprinted with permission. (b) Reprinted with permission from *Vision Research*, 15, G. Westheimer & G. Hauske, Temporal and spatial interference with vernier acuity, copyright © 1975, Pergamon Journals Ltd.
- 1.608, Fig. 1: From L. Olzak & J. P. Thomas, Seeing spatial patterns, in K. R. Boff, L. Kaufman, & J. P. Thomas (Eds.), *Handbook of perception and human performance: Volume I. Sensory processes and perception*. Copyright © 1986 by John Wiley & Sons, Inc. Reprinted with permission.
- 1.609, Fig. 1: From G. Westheimer, The spatial sense of the eye, *Investigative Ophthalmology and Visual Science*, 1979, 18. Reprinted with permission.

- 1.610, Fig. 1: Reprinted with permission from *Vision Research*, 21, L. Martin, J. Pola, E. Martin, & E. Picoult, Vernier discrimination with sequentially-flashed lines: Roles of eye movements, retinal off sets and short-term memory, copyright © 1981, Pergamon Press Ltd.
- 1.611, Fig. 1: Reprinted with permission from *Vision Research*, 22, G. Westheimer, The spatial grain of the perifoveal visual field, copyright © 1982, Pergamon Press Ltd.
- 1.611, Fig. 2: From L. Olzak & J. P. Thomas, Seeing spatial patterns, in K. R. Boff, L. Kaufman, & J. P. Thomas (Eds.), *Handbook of perception and human performance: Volume 1. Sensory processes and perception*. Copyright © 1986 by John Wiley & Sons, Inc. Reprinted with permission.
- 1.613, Fig. 1: From *Design handbook for imagery interpretation equipment*, R. J. Farrell & J. M. Booth, Boeing Aerospace Co., Seattle, WA, 1975.
- 1.614, Fig. 1: From L. A. Riggs, Visual acuity, in C. H. Graham (Ed.), *Vision and visual perception*. Copyright © 1966 by John Wiley & Sons, Inc. Reprinted with permission.
- 1.615, Fig. 1: (b) From M. Luckiesh & F. K. Moss, The variation in visual acuity with fixation distance, *Journal of the Optical Society of America*, 1941, 31. Reprinted with permission. (c) From R. J. Farrell, C. D. Anderson, C. L. Kraft, & G. P. Boucek, *Effects of convergence and accommodation on stereopsis* (Document No. D180-19051-1), Boeing Aerospace, 1970. Reprinted with permission. (d) From J. P. Brown, K. N. Ogle, & L. Rieher, Stereoscopic acuity and observation distance, *Investigative Ophthalmology*, 1965, 4. Reprinted with permission. (e) From G. Amigo, Variation of stereoscopic acuity with observation distance, *Journal of the Optical Society of America*, 1963, 53. Reprinted with permission.
- 1.617, Fig. 1: From E. Ludvigh & J. W. Miller, Study of visual acuity during the ocular pursuit of moving test objects. I. Introduction. *Journal of the Optical Society of America*, 1958, 48. Reprinted with permission.
- 1.617, Fig. 2: From J. W. Miller & E. Ludvigh, The effects of relative motion on visual acuity, *Survey of Ophthalmology*, 7(2), 83-116. © by Williams & Wilkins, 1962. Reprinted with permission.
- 1.619, Fig. 1: From J. W. Miller, Study of visual acuity during the ocular pursuit of moving test objects. II. Effects of direction of movement, relative movement and illumination, *Journal of the Optical Society of America*, 1958, 48. Reprinted with permission.
- 1.619, Fig. 2: From J. W. Miller, Study of visual acuity during the ocular pursuit of moving test objects. II. Effects of direction of movement, relative movement and illumination, *Journal of the Optical Society of America*, 1958, 48. Reprinted with permission.
- 1.622, Fig. 1: From J. W. Miller & E. Ludvigh, The effects of relative motion on visual acuity, *Survey of Ophthalmology*, 7, 83-116. © by Williams & Wilkins, 1962. Reprinted with permission.
- 1.623, Fig. 1: From D. Pitts, The effects of aging on selected visual functions: Dark adaptation, visual acuity, stereopsis and brightness contrast, in R. Sekuler, D. Kline, & K. Dismukes (Eds.), *Aging in human visual function*. Liss, 1982. Reprinted by permission.
- 1.623, Fig. 2: Reprinted with permission from *Vision Research*, 23, C. Owsley, R. Sekuler, & P. Siemsen, Contrast sensitivity throughout adulthood, copyright © 1983, Pergamon Press Ltd.
- 1.625, Fig. 1: From L. Olzak & J. P. Thomas, Seeing spatial patterns, in K. R. Boff, L. Kaufman, & J. P. Thomas (Eds.), *Handbook of perception and human performance: Volume 1. Sensory processes and perception*. Copyright © 1986 by John Wiley & Sons, Inc. Reprinted with permission.
- 1.626, Fig. 1: Reprinted with permission from *Vision Research*, 13, F. M. Bagrash, Size-selection adaptation: Psychophysical evidence for size-tuning and the effects of stimulus contour and adapting flux, copyright © 1973, Pergamon Press Ltd.
- 1.626, Fig. 2: Reprinted with permission from *Vision Research*, 13, F. M. Bagrash, Size-selection adaptation: Psychophysical evidence for size-tuning and the effects of stimulus contour and adapting flux, copyright © 1973, Pergamon Press Ltd.
- 1.627, Fig. 1: From L. Olzak & J. P. Thomas, Seeing spatial patterns, in K. R. Boff, L. Kaufman, & J. P. Thomas (Eds.), *Handbook of perception and human performance: Volume 1. Sensory processes and perception*. Copyright © 1986 by John Wiley & Sons, Inc. Reprinted with permission.
- 1.629, Fig. 1: From F. W. Campbell & J. G. Robson, Application of Fourier analysis to the visibility of gratings, *Journal of Physiology*, 1968, 197. Reprinted with permission.
- 1.630, Fig. 1: Reprinted with permission from *Vision Research*, 11, N. Graham & J. Nachmias, Detection of grating patterns containing two spatial frequencies: A comparison of single channel and multiple channel models, copyright © 1971, Pergamon Press Ltd.
- 1.630, Fig. 2: Reprinted with permission from *Vision Research*, 11, N. Graham & J. Nachmias, Detection of grating patterns containing two spatial frequencies: A comparison of single channel and multiple channel models, copyright © 1971, Pergamon Press Ltd.
- 1.631, Fig. 1: Reprinted with permission from *Vision Research*, 14, J. Hoekstra, D. P. J. van der Goot, G. van den Brink, & F. A. Bilsen, The influence of the number of cycles upon the visual contrast threshold, copyright © 1974, Pergamon Press Ltd.
- 1.631, Fig. 2: Reprinted with permission from *Vision Research*, 14, J. Hoekstra, D. P. J. van der Goot, G. van den Brink, & F. A. Bilsen, The influence of the number of cycles upon the visual contrast threshold, copyright © 1974, Pergamon Press Ltd.
- 1.632, Fig. 1: From F. L. Van Nes & M. A. Bouman, Spatial modulation transfer in the human eye, *Journal of the Optical Society of America*, 1967, 57. Reprinted with permission.
- 1.632, Fig. 2: From F. L. Van Nes & M. A. Bouman, Spatial modulation transfer in the human eye, *Journal of the Optical Society of America*, 1967, 57. Reprinted with permission.
- 1.632, Fig. 3: From F. L. Van Nes & M. A. Bouman, Spatial modulation transfer in the human eye, *Journal of the Optical Society of America*, 1967, 57. Reprinted with permission.
- 1.632, Fig. 4: From D. Hood & M. Finkelstein, Sensitivity to light, in K. R. Boff, L. Kaufman, & J. P. Thomas (Eds.), *Handbook of perception and human performance: Volume 1. Sensory processes and perception*. Copyright © 1986 by John Wiley & Sons, Inc. Reprinted with permission.
- 1.633, Fig. 1: From M. Aguilar & W. S. Stiles, Saturation of the rod mechanism of the retina at high levels of stimulation, *Optica Acta*, 1954, 1. Reprinted with permission.
- 1.634, Fig. 1: From D. E. Mitchell & F. Wilkinson, The effect of early astigmatism on the visual resolution of gratings, *Journal of Physiology*, 1974, 243. Reprinted with permission.
- 1.635, Fig. 1: Reprinted with permission from *Vision Research*, 21, J. G. Robson & N. Graham, Probability summation of regional variation in contrast sensitivity across the visual field, copyright © 1981, Pergamon Press Ltd.
- 1.636, Fig. 1: From H. R. Blackwell & A. B. Moldauer, *Detection thresholds for point sources in the near periphery* (DTIC AD 759739), as shown in figure 3.5-12 of *Design handbook for imagery interpretation equipment* by R. J. Farrell & J. M. Booth, Document D180-19063-1, Boeing Aerospace Co., Seattle, WA, 1975.
- 1.637, Fig. 1: From *Human Factors*, 1972, 14(3), 199-205. Copyright © 1972 by the Human Factors Society, Inc. and reproduced by permission.
- 1.637, Fig. 2: From *Human Factors*, 1972, 14(3), 204. Copyright © 1972 by the Human Factors Society, Inc. and reproduced by permission.
- 1.638, Fig. 1: From F. W. Campbell & D. G. Green, Optical and retinal factors affecting visual resolution, *Journal of Physiology*, 1965, 181. Reprinted with permission.
- 1.640, Fig. 1: From H. Pollehn & H. Roehrig, Effect of noise on the modulation transfer function of the visual channel, *Journal of the Optical Society of America*, 1970, 60. Reprinted with permission.
- 1.640, Fig. 2: From H. Pollehn & H. Roehrig, Effect of noise on the modulation transfer function of the visual channel, *Journal of the Optical Society of America*, 1970, 60. Reprinted with permission.
- 1.641, Fig. 1: Reprinted with permission from *Vision Research*, 4, R. Shapley, Gaussian bars and rectangular bars: The influence of width and gradient on visibility, copyright © 1974, Pergamon Press Ltd.
- 1.642, Fig. 1: From G. A. Fry, Visibility of sine-wave gratings, *Journal of the Optical Society of America*, 1969, 59. Reprinted with permission.
- 1.643, Fig. 1: From S. K. Guth & J. F. McNelis, Threshold contrast as a function of target complexity, *Archives of the American Academy of Optometry*, 1969, 46. Copyright © 1969 by the American Academy of Optometry.
- 1.643, Fig. 2: From S. K. Guth & J. F. McNelis, Threshold contrast as a function of target complexity, *Archives of the American Academy of Optometry*, 1969, 46. Copyright © 1969 by the American Academy of Optometry, as shown in figure 3.1-14 of *Design handbook for imagery interpretation equipment*, R. J. Farrell & J. M. Booth, Boeing Aerospace Co., Seattle, WA, 1975.
- 1.643, Fig. 3: From S. K. Guth & J. F. McNelis, Threshold contrast as a function of target complexity, *Archives of the American Academy of Optometry*, 1969, 46. Copyright © 1969 by the American Academy of Optometry. Reprinted with permission.

- 1.644, Fig. 1: From A. P. Ginsburg, *Visual information processing based on spatial filters constrained by biological data*, unpublished doctoral dissertation, University of Cambridge, England, 1978; and A. P. Ginsburg, Spatial filtering and vision: Implications for normal and abnormal vision, in L. M. Proenza, J. M. Enoch, & G. A. Jampolski (Eds.), *Clinical applications of visual psychophysics*, Cambridge University Press, 1981; and A. P. Ginsburg, Specifying relevant spatial information for image evaluation and display design: An explanation of how we see certain objects, *Society for Information Display*, 1980, 21.
- 1.645, Fig. 1: From A. P. Ginsburg, D. W. Evans, M. W. Cannon, C. Owsley, & P. Mulvanny, Large sample norms for contrast sensitivity, *American Journal of Optometry and Physiological Optics*, 1984, 61. Reprinted with permission.
- 1.646, Fig. 1: From G. E. Legge & J. M. Foley, Contrast masking in human vision, *Journal of the Optical Society of America*, 1980, 70. Reprinted with permission.
- 1.647, Fig. 1: From M. A. Georgeson & G. O. Sullivan, Contrast constancy: Deblurring in human vision by spatial frequency channels, *Journal of Physiology*, 1975, 252. Reprinted with permission.
- 1.648, Fig. 1: From J. Hirsch & R. Hylton, Limits of spatial frequency discrimination as evidence of neural interpolation, *Journal of the Optical Society of America*, 1982, 72. Reprinted with permission.
- 1.649, Fig. 1: From L. Olzak & J. P. Thomas, Seeing spatial patterns, in K. R. Boff, L. Kaufman, & J. P. Thomas (Eds.), *Handbook of perception and human performance: Volume 1. Sensory processes and perception*. Copyright © 1986 by John Wiley & Sons, Inc. Reprinted with permission.
- 1.650, Fig. 1: Reprinted with permission from *Vision Research*, 18, D. J. Tolhurst & L. P. Barfield, Interaction between spatial frequency channels, copyright © 1978, Pergamon Press Ltd.
- 1.651, Fig. 1: From C. Blakemore & F. W. Campbell, On the existence of neurones in the human visual system selectively sensitive to the orientation and size of retinal images, *Journal of Physiology*, 1969, 203. Reprinted with permission.
- 1.652, Fig. 1: Reprinted with permission from *Vision Research*, 13, J. J. Kulikowski, R. Abadi, & P. E. King-Smith, Orientational selectivity of grating and line detectors in human vision, copyright © 1973, Pergamon Press Ltd.
- 1.653, Fig. 1: From L. Olzak & J. P. Thomas, Seeing spatial patterns, in K. R. Boff, L. Kaufman, & J. P. Thomas (Eds.), *Handbook of perception and human performance: Volume 1. Sensory processes and perception*. Copyright © 1986 by John Wiley & Sons, Inc. Reprinted with permission.
- 1.654, Fig. 1: From L. Olzak & J. P. Thomas, Seeing spatial patterns, in K. R. Boff, L. Kaufman, & J. P. Thomas (Eds.), *Handbook of perception and human performance: Volume 1. Sensory processes and perception*. Copyright © 1986 by John Wiley & Sons, Inc. Reprinted with permission.
- 1.655, Fig. 1: From L. Olzak & J. P. Thomas, Seeing spatial patterns, in K. R. Boff, L. Kaufman, & J. P. Thomas (Eds.), *Handbook of perception and human performance: Volume 1. Sensory processes and perception*. Copyright © 1986 by John Wiley & Sons, Inc. Reprinted with permission.
- 1.655, Fig. 2: From J. P. Thomas, J. Gille, & R. A. Barker, Simultaneous visual detection and identification: Theory and data, *Journal of the Optical Society of America*, 1982, 72. Reprinted with permission.
- 1.655, Fig. 3: From J. P. Thomas, Underlying psychometric function for detecting gratings and identifying spatial frequency, *Journal of the Optical Society of America*, 1983, 73. Reprinted with permission.
- 1.657, Fig. 1: From H. R. Blackwell, Evaluation of the neural quantum theory in vision, *American Journal of Psychology*, 1953, 66. Copyright by the University of Illinois Press.
- 1.657, Fig. 2: From J. P. Guilford, *Psychometric methods*. Copyright © 1936 by McGraw-Hill. Reprinted with permission.
- 1.657, Fig. 3: From W. J. Crozier, *Journal of General Physiology*, 1950, 34, 87-136. Reprinted with permission of the Helen Dwight Reid Educational Foundation. Published by Heldref Publications.
- 1.657, Fig. 4: From L. Olzak & J. P. Thomas, Seeing spatial patterns, in K. R. Boff, L. Kaufman, & J. P. Thomas (Eds.), *Handbook of perception and human performance: Volume 1. Sensory processes and perception*. Copyright © 1986 by John Wiley & Sons, Inc. Reprinted with permission.
- 1.701, Fig. 1: From G. Wyszecki, Color appearance, in K. R. Boff, L. Kaufman, & J. P. Thomas (Eds.), *Handbook of perception and human performance: Volume 1. Sensory processes and perception*. Copyright © 1986 by John Wiley & Sons, Inc. Reprinted with permission.
- 1.701, Fig. 2: From G. Wyszecki, Color appearance, in K. R. Boff, L. Kaufman, & J. P. Thomas (Eds.), *Handbook of perception and human performance: Volume 1. Sensory processes and perception*. Copyright © 1986 by John Wiley & Sons, Inc. Reprinted with permission.
- 1.702, Fig. 1: From W. D. Wright, *Research on normal and defective colour vision*, Kimpton Medical Publishers, 1946.
- 1.702, Fig. 2: From J. Pokorny & V. C. Smith, Colorimetry and color discrimination, in K. R. Boff, L. Kaufman, & J. P. Thomas (Eds.), *Handbook of perception and human performance: Volume 1. Sensory processes and perception*. Copyright © 1986 by John Wiley & Sons, Inc. Reprinted with permission.
- 1.702, Fig. 3: From J. Pokorny & V. C. Smith, Colorimetry and color discrimination, in K. R. Boff, L. Kaufman, & J. P. Thomas (Eds.), *Handbook of perception and human performance: Volume 1. Sensory processes and perception*. Copyright © 1986 by John Wiley & Sons, Inc. Reprinted with permission.
- 1.702, Fig. 4: From W. D. Wright, *Research on normal and defective colour vision*, Kimpton Medical Publishers, 1946.
- 1.702, Fig. 5: From W. D. Wright, *Research on normal and defective colour vision*, Kimpton Medical Publishers, 1946.
- 1.703, Fig. 1: From L. A. Jones & E. M. Lowry, Retinal sensibility to saturation differences, *Journal of the Optical Society of America*, 1926, 16. Reprinted with permission.
- 1.704, Fig. 1: From J. Pokorny & V. C. Smith, Colorimetry and color discrimination, in K. R. Boff, L. Kaufman, & J. P. Thomas (Eds.), *Handbook of perception and human performance: Volume 1. Sensory processes and perception*. Copyright © 1986 by John Wiley & Sons, Inc. Reprinted with permission.
- 1.704, Fig. 2: From W. D. Wright, *Research on normal and defective colour vision*, Kimpton Medical Publishers, 1946.
- 1.704, Fig. 3: From D. L. MacAdam, Visual sensitivities to color differences in daylight, *Journal of the Optical Society of America*, 1942, 32. Reprinted with permission.
- 1.704, Fig. 4: From G. Wyszecki & G. H. Fielder, New color-matching ellipses, *Journal of the Optical Society of America*, 1971, 61. Reprinted with permission.
- 1.706, Tab. 1: From D. B. Judd, Basic correlates of the visual system, in S. S. Stevens (Ed.), *Handbook of experimental psychology*, John Wiley & Sons, 1951.
- 1.708, Fig. 1: From G. Wyszecki, Color appearance, in K. R. Boff, L. Kaufman, & J. P. Thomas (Eds.), *Handbook of perception and human performance: Volume 1. Sensory processes and perception*. Copyright © 1986 by John Wiley & Sons, Inc. Reprinted with permission.
- 1.709, Fig. 2: From R. M. Boynton & J. Gordon, Bezold-Brücke hue shift measured by color-naming technique, *Journal of the Optical Society of America*, 1965, 55. Reprinted with permission.
- 1.709, Fig. 3: From R. M. Boynton & J. Gordon, Bezold-Brücke hue shift measured by color-naming technique, *Journal of the Optical Society of America*, 1965, 55. Reprinted with permission.
- 1.710, Fig. 1: From D. B. Judd & G. Wyszecki, *Color in business, science, and industry* (3rd ed.). Copyright © 1975 by John Wiley & Sons, Inc. Reprinted with permission.
- 1.710, Fig. 2: From C. J. Bartleson, *Factors affecting color appearance and measurement by psychophysical methods*, Unpublished doctoral dissertation, City University of London, England, 1977. Reprinted with permission.
- 1.710, Fig. 3: From C. J. Bartleson, *Factors affecting color appearance and measurement by psychophysical methods*, Unpublished doctoral dissertation, City University of London, England, 1977. Reprinted with permission.
- 1.711, Fig. 1: From G. Wyszecki, Color appearance, in K. R. Boff, L. Kaufman, & J. P. Thomas (Eds.), *Handbook of perception and human performance: Volume 1. Sensory processes and perception*. Copyright © 1986 by John Wiley & Sons, Inc. Reprinted with permission.
- 1.711, Fig. 2: From L. M. Hurvich & D. Jameson, Some quantitative aspects of an opponent-colors theory: II. Brightness, saturation, and hue in normal and dichromatic vision, *Journal of the Optical Society of America*, 1955, 45. Reprinted with permission.
- 1.711, Fig. 3: From L. M. Hurvich & D. Jameson, Some quantitative aspects of an opponent-colors theory: II. Brightness, saturation, and hue in normal and dichromatic vision, *Journal of the Optical Society of America*, 1955, 45. Reprinted with permission.
- 1.713, Fig. 2: From G. Wyszecki, Color appearance, in K. R. Boff, L. Kaufman, & J. P. Thomas (Eds.), *Handbook of perception and human performance: Volume 1. Sensory processes and perception*. Copyright © 1986 by John Wiley & Sons, Inc. Reprinted with permission.

- 1.714, Fig. 1: From W. Benary, Beobachtung zu einer Experiment über Helligkeitskontrast, *Psychologische Forschung*, 1924, 4. Reprinted with permission.
- 1.714, Fig. 2: From I. Rock, The description and analysis of object and event perception, in K. R. Boff, L. Kaufman, & J. P. Thomas (Eds.), *Handbook of perception and human performance: Volume II. Cognitive processes and performance*. Copyright © 1986 by John Wiley & Sons, Inc. Reprinted with permission.
- 1.714, Fig. 3: From W. Metzger, *Gesetze des Sehens*, Waldemar Kramer, 1953.
- 1.715, Fig. 1: Reprinted with permission from *Vision Research*, 4, D. Jameson & L. M. Hurvich, Theory of brightness and color contrast in human vision, copyright © 1964, Pergamon Press Ltd.
- 1.716, Fig. 1: From A. Fiorentini, Mach band phenomena, in D. Jameson & L. M. Hurvich (Eds.), *Visual psychophysics*, Springer-Verlag, 1972. Reprinted with permission.
- 1.716, Fig. 2: From A. Fiorentini, Mach band phenomena, in D. Jameson & L. M. Hurvich (Eds.), *Visual psychophysics*, Springer-Verlag, 1972. Reprinted with permission.
- 1.717, Fig. 1: From G. Wyszecki, Color appearance, in K. R. Boff, L. Kaufman, & J. P. Thomas (Eds.), *Handbook of perception and human performance: Volume I. Sensory processes and perception*. Copyright © 1986 by John Wiley & Sons, Inc. Reprinted with permission.
- 1.717, Fig. 2: Reprinted with permission from *Vision Research*, 22, C. Ware & W. Cowan, Changes in perceived color due to chromatic aberrations, copyright © 1982, Pergamon Journals Ltd.
- 1.719, Fig. 1: From G. Wyszecki, Color appearance, in K. R. Boff, L. Kaufman, & J. P. Thomas (Eds.), *Handbook of perception and human performance: Volume I. Sensory processes and perception*. Copyright © 1986 by John Wiley & Sons, Inc. Reprinted with permission.
- 1.719, Fig. 2: From *Color vision* by L. M. Hurvich, 1981. Reprinted by permission.
- 1.719, Fig. 3: From G. Wyszecki, Color appearance, in K. R. Boff, L. Kaufman, & J. P. Thomas (Eds.), *Handbook of perception and human performance: Volume I. Sensory processes and perception*. Copyright © 1986 by John Wiley & Sons, Inc. Reprinted with permission.
- 1.720, Fig. 1: From G. Wyszecki, Color appearance, in K. R. Boff, L. Kaufman, & J. P. Thomas (Eds.), *Handbook of perception and human performance: Volume I. Sensory processes and perception*. Copyright © 1986 by John Wiley & Sons, Inc. Reprinted with permission.
- 1.721, Fig. 1: From G. Wyszecki & W. S. Stiles, *Color science* (2nd ed.), John Wiley & Sons, Inc., © 1982. Reprinted with permission.
- 1.722, Fig. 1: From G. Wyszecki & W. S. Stiles, *Color science* (2nd ed.), John Wiley & Sons, © 1982.
- 1.722, Fig. 2: From G. Wyszecki & W. S. Stiles, *Color science* (2nd ed.), John Wiley & Sons, © 1982.
- 1.722, Fig. 3: From G. Wyszecki & W. S. Stiles, *Color science* (2nd ed.), John Wiley & Sons, © 1982.
- 1.722, Fig. 4: From G. Wyszecki & W. S. Stiles, *Color science* (2nd ed.), John Wiley & Sons, © 1982.
- 1.722, Fig. 5: From G. Wyszecki & W. S. Stiles, *Color science* (2nd ed.), John Wiley & Sons, © 1982.
- 1.724, Fig. 1: From D. B. Judd & G. Wyszecki, *Color in business, science, and industry*, John Wiley & Sons, Inc., copyright © 1975. Reprinted with permission.
- 1.724, Fig. 2: From D. B. Judd & G. Wyszecki, *Color in business, science, and industry*, John Wiley & Sons, Inc., copyright © 1975. Reprinted with permission.
- 1.724, Fig. 3: From D. B. Judd & G. Wyszecki, *Color in business, science, and industry*, John Wiley & Sons, Inc., copyright © 1975. Reprinted with permission.
- 1.725, Fig. 1: From G. Wyszecki, Color appearance, in K. R. Boff, L. Kaufman, & J. P. Thomas (Eds.), *Handbook of perception and human performance: Volume I. Sensory processes and perception*. Copyright © 1986 by John Wiley & Sons, Inc. Reprinted with permission.
- 1.725, Fig. 2: From G. Wyszecki & W. S. Stiles, *Color science* (2nd ed.), John Wiley & Sons, Inc., © 1982. Reprinted with permission.
- 1.726, Tab. 1: D. B. Judd & G. Wyszecki, *Color in business, science, and industry*, as shown in figure 5.2-19 of *Design handbook for imagery interpretation equipment* by R. J. Farrell & J. M. Booth, Document D180-19063-1, Boeing Aerospace Co., Seattle, WA, 1975.
- 1.802, Fig. 1: From F. W. Campbell & D. G. Green, Monocular versus binocular visual acuity. Reprinted by permission from *Nature*, 208, 191-192. Copyright © 1965 Macmillan Journals Limited.
- 1.803, Fig. 1: From W. J. M. Levelt, *On binocular rivalry*, Mouton Publishers, 1968. Reprinted with permission.
- 1.803, Fig. 2: From G. E. Legge & G. S. Rubin, Binocular interactions in suprathreshold contrast perception, *Perception and Psychophysics*, 1981, 28. Reprinted with permission.
- 1.804, Fig. 1: From A. Arditi, Binocular vision, in K. R. Boff, L. Kaufman, & J. P. Thomas (Eds.), *Handbook of perception and human performance: Volume I. Sensory processes and perception*. Copyright © 1986 by John Wiley & Sons, Inc. Reprinted with permission.
- 1.805, Fig. 1: From L. Kaufman, On the spread of suppression and binocular rivalry, *Vision Research*, 3, copyright © 1963 by Pergamon Press Ltd. Reprinted with permission.
- 1.805, Fig. 2: From L. Kaufman, On the spread of suppression and binocular rivalry, *Vision Research*, 3, copyright © 1963 by Pergamon Press Ltd. Reprinted with permission.
- 1.809, Fig. 2: From R. J. Farrell & J. M. Booth, *Design handbook for imagery interpretation equipment*, Document D180-19063-1, Boeing Aerospace Co., Seattle, WA, 1975.
- 1.810, Fig. 1: From *Design handbook for imagery interpretation equipment*, R. J. Farrell & J. M. Booth, Document D180-19063-1, Boeing Aerospace Co., Seattle, WA, 1975.
- 1.810, Fig. 2: From *Design handbook for imagery interpretation equipment*, R. J. Farrell & J. M. Booth, Document D180-19063-1, Boeing Aerospace Co., Seattle, WA, 1975.
- 1.811, Fig. 1: From R. Blake & R. Cormack, On utricular discrimination, *Perception and Psychophysics*, 1979, 26. Reprinted with permission.
- 1.812, Fig. 1: From *Design handbook for imagery interpretation equipment*, R. J. Farrell & J. M. Booth, Document D180-19063-1, Boeing Aerospace Co., Seattle, WA, 1975.
- 1.901, Fig. 1: From H. B. Barlow & J. D. Mollon (Eds.), *The senses*. Copyright 1982 by Cambridge University Press. Reprinted by permission.
- 1.901, Fig. 2: Reproduced by permission from R. A. Moses (Ed.), *Adler's physiology of the eye: Clinical application* (7th ed.), St. Louis, 1981, The C. V. Mosby Co.
- 1.901, Fig. 3: Reproduced by permission from R. A. Moses (Ed.), *Adler's physiology of the eye: Clinical application* (7th ed.), St. Louis, 1981, The C. V. Mosby Co.
- 1.901, Fig. 4: From P. Hallett, Human eye movements, in K. R. Boff, L. Kaufman, & J. P. Thomas (Eds.), *Handbook of perception and human performance: Volume I. Sensory processes and perception*. Copyright © 1986 by John Wiley & Sons, Inc. Reprinted by permission.
- 1.903, Fig. 1: From P. Hallett, Human eye movements, in K. R. Boff, L. Kaufman, & J. P. Thomas (Eds.), *Handbook of perception and human performance: Volume I. Sensory processes and perception*. Copyright © 1986 by John Wiley & Sons, Inc. Reprinted with permission.
- 1.903, Fig. 2: From P. Hallett, Human eye movements, in K. R. Boff, L. Kaufman, & J. P. Thomas (Eds.), *Handbook of perception and human performance: Volume I. Sensory processes and perception*. Copyright © 1986 by John Wiley & Sons, Inc. Reprinted with permission.
- 1.903, Fig. 3: From P. Hallett, Human eye movements, in K. R. Boff, L. Kaufman, & J. P. Thomas (Eds.), *Handbook of perception and human performance: Volume I. Sensory processes and perception*. Copyright © 1986 by John Wiley & Sons, Inc. Reprinted with permission.
- 1.905, Fig. 1: Reproduced by permission from R. A. Moses (Ed.), *Adler's physiology of the eye: Clinical application* (7th ed.), St. Louis, 1981, The C. V. Mosby Co.
- 1.906, Tab. 1: From R. N. Haber & M. Hershenson, *The psychology of visual perception*. Copyright © 1980 by Holt, Rinehart & Winston. Reprinted by permission of CBS College Publishing.
- 1.908, Fig. 1: From A. T. Bahill & L. Stark, Overlapping saccades and glissades are produced by fatigue in the saccadic eye movements system, *Experimental Neurology*, 48. Copyright © 1975 by Academic Press, Inc. Reprinted by permission.
- 1.910, Fig. 2: From V. Henn, B. Cohen, & L. R. Young, Visual-vestibular interactions in motion perception and the generation of nystagmus, *Neurosciences Research Program Bulletin*, 1980, 18(4).
- 1.910, Fig. 3: From V. Henn, B. Cohen, & L. R. Young, Visual-vestibular interactions in motion perception and the generation of nystagmus, *Neurosciences Research Program Bulletin*, 1980, 18(4).
- 1.911, Fig. 1: Reprinted with permission from *Vision Research*, 10, A. A. Skavenski & R. M. Steinman, Control of eye position in the dark, copyright © 1970, Pergamon Press Ltd.

- 1.912, Fig. 1: From L. A. Riggs, J. C. Armington, & F. Ratliff, Motions of the retinal image during fixation, *Journal of the Optical Society of America*, 1954, 44. Reprinted with permission.
- 1.913, Fig. 1: Reprinted with permission from *Vision Research*, 20, R. M. Steinman & H. Collewijn, Binocular retinal image motion during active head rotation, copyright © 1980, Pergamon Press Ltd.
- 1.916, Fig. 1: Reprinted with permission from *Vision Research*, 8, R. M. Steinman & R. J. Cunitz, Fixation of targets near the absolute foveal threshold, copyright © 1968, Pergamon Press Ltd.
- 1.917, Fig. 1: From C. C. Varr, L. W. Schultheis, & D. A. Robinson, Voluntary non-visual control of the human vestibulo-ocular reflex, *Acta Otolaryngologica*, 1976, 81. Reprinted with permission.
- 1.917, Fig. 2: From P. D. Pulaski, D. S. Zee, & D. A. Robinson, The behavior of the vestibulo-ocular reflex at high velocities of head rotation, *Brain Research*, 1981, 222. Reprinted with permission.
- 1.919, Fig. 1: From A. J. Benson & F. E. Guedry, Comparison of tracking-task performance and nystagmus during sinusoidal oscillation in yaw and pitch, *Aerospace Medicine*, 1971, 42. Reprinted with permission.
- 1.919, Fig. 2: From A. J. Benson & F. E. Guedry, Comparison of tracking-task performance and nystagmus during sinusoidal oscillation in yaw and pitch, *Aerospace Medicine*, 1971, 42. Reprinted with permission.
- 1.920, Fig. 1: From G. R. Barnes, A. J. Benson, & A. R. J. Prior, Visual-vestibular interaction in the control of eye movement, *Aviation, Space, and Environmental Medicine*, 1978, 49. Reprinted with permission.
- 1.920, Fig. 2: From G. R. Barnes, A. J. Benson, & A. R. J. Prior, Visual-vestibular interaction in the control of eye movement, *Aviation, Space, and Environmental Medicine*, 1978, 49. Reprinted with permission.
- 1.921, Fig. 1: From G. Melvill Jones, Vestibulo-ocular disorganization in the aerodynamic spin, *Aerospace Medicine*, 1965, 36. Reprinted with permission.
- 1.921, Fig. 2: From G. Melvill Jones, Vestibulo-ocular disorganization in the aerodynamic spin, *Aerospace Medicine*, 1965, 36. Reprinted with permission.
- 1.922, Fig. 2: From P. D. Pulaski, D. S. Zee, & D. A. Robinson, The behavior of the vestibulo-ocular reflex at high velocities of head rotation, *Brain Research*, 1981, 222. Reprinted with permission.
- 1.925, Fig. 1: From V. Honrubia, W. L. Downey, D. P. Mitchell, B. A. Ward, & P. H. Ward, Experimental studies on optokinetic nystagmus. II. Normal humans, *Acta Otolaryngologica*, 1968, 65. Reprinted with permission.
- 1.927, Fig. 1: From A. Gonshor & G. Melvill Jones, Extreme vestibulo-ocular adaptation induced by prolonged optical reversal of vision, *Journal of Physiology*, 1976, 256. Reprinted with permission.
- 1.929, Tab. 1: From A. Sokolovski, The influence of mental activity and visual fixation upon caloric-induced nystagmus in normal subjects, *Acta Otolaryngologica*, 1966, 61. Reprinted with permission.
- 1.930, Fig. 1: From R. Malcolm & G. Melvill Jones, A quantitative study of vestibular adaptation in humans, *Acta Otolaryngologica*, 1970, 70. Reprinted with permission.
- 1.930, Fig. 2: From R. Malcolm, & G. Melvill Jones, A quantitative study of vestibular adaptation in humans, *Acta Otolaryngologica*, 1970, 70. Reprinted with permission.
- 1.931, Fig. 1: Reprinted with permission from *Vision Research*, 9, W. Becker & A. F. Fuchs, Further properties of the human saccadic system: Eye movements and correction saccades with and without visual fixation points, copyright © 1969, Pergamon Journals Ltd.
- 1.931, Fig. 2: Reprinted with permission from *Vision Research*, 9, W. Becker & A. F. Fuchs, Further properties of the human saccadic system: Eye movements and correction saccades with and without visual fixation points, copyright © 1969, Pergamon Journals Ltd.
- 1.931, Fig. 3: Reprinted with permission from *Vision Research*, 13, W. Becker & H. M. Klein, Accuracy of saccadic eye movements and maintenance of eccentric eye positions in the dark, copyright © 1973, Pergamon Journals Ltd.
- 1.934, Fig. 1: From J. M. Findlay, The visual stimulus for saccadic eye movements in human observers, *Perception*, 1980, 9. Reprinted with permission.
- 1.935, Fig. 1: Reprinted with permission from *Vision Research*, 18, P. E. Hallett, Primary and secondary saccades to goals defined by instructions, copyright © 1978, Pergamon Press Ltd.
- 1.935, Fig. 2: Reprinted with permission from *Vision Research*, 18, P. E. Hallett, Primary and secondary saccades to goals defined by instructions, copyright © 1978, Pergamon Press Ltd.
- 1.936, Fig. 1: From P. E. Hallett, Saccades to flashes, in R. A. Monty & J. W. Sendes (Eds.), *Eye movements and psychological processes*, Lawrence Erlbaum, 1976.
- 1.936, Fig. 2: From *Vision Research*, 16, P. E. Hallett & A. D. Lightstone, Saccadic eye movements toward stimuli, copyright © 1976, Pergamon Press Ltd.
- 1.936, Fig. 3: From *Vision Research*, 16, P. E. Hallett & A. D. Lightstone, Saccadic eye movements toward stimuli, copyright © 1976, Pergamon Press Ltd.
- 1.937, Fig. 1: Reprinted with permission from *Vision Research*, 20, P. E. Hallett & B. D. Adams, Predictability of saccadic latency in a novel voluntary oculomotor task, copyright © 1980, Pergamon Press Ltd.
- 1.937, Fig. 2: Reprinted with permission from *Vision Research*, 20, P. E. Hallett & B. D. Adams, Predictability of saccadic latency in a novel voluntary oculomotor task, copyright © 1980, Pergamon Press Ltd.
- 1.938, Fig. 1: From L. Matin, Visual localization and eye movements, in K. R. Boff, L. Kaufman, & J. P. Thomas (Eds.), *Handbook of perception and human performance: Volume I. Sensory processes and perception*. Copyright © 1986 by John Wiley & Sons, Inc. Reprinted with permission.
- 1.940, Fig. 1: Reprinted with permission from *Vision Research*, 9, G. J. St.-Cyr & D. H. Fender, Nonlinearity of the human oculomotor system: Gain, copyright © 1969, Pergamon Press Ltd.
- 1.941, Fig. 1: Reprinted with permission from *Vision Research*, 18, B. J. Winterson & R. M. Steinman, The effect of luminance on human smooth pursuit of perifoveal and foveal targets, copyright © 1978, Pergamon Press Ltd.
- 1.942, Fig. 1: From D. A. Robinson, The mechanics of human smooth pursuit eye movement, *Journal of Physiology*, 1965, 180. Reprinted with permission.
- 1.943, Fig. 1: Reprinted with permission from *Vision Research*, 6, J. A. Michael & G. Melvill Jones, Dependence of visual tracking capability upon stimulus predictability, copyright © 1966, Pergamon Press Ltd.
- 1.944, Fig. 1: Reprinted with permission from *Vision Research*, 9, G. J. St.-Cyr & D. H. Fender, Nonlinearities of the human oculomotor system: Gain, copyright © 1969, Pergamon Press Ltd.
- 1.945, Fig. 1: Reprinted with permission from *Vision Research*, 9, R. M. Steinman, A. A. Skavenski, & R. V. Sansbury, Voluntary control of smooth pursuit velocity, copyright © 1969, Pergamon Press Ltd.
- 1.946, Fig. 1: From M. J. Steinbach, Eye tracking of self-moved targets: The role of efference, *Journal of Experimental Psychology*, 82. Copyright 1969 by the American Psychological Association. Reprinted by permission of the author.
- 1.946, Fig. 2: From M. J. Steinbach, Eye tracking of self-moved targets: The role of efference, *Journal of Experimental Psychology*, 82. Copyright 1969 by the American Psychological Association. Reprinted by permission of the author.
- 1.947, Fig. 1: From A. Mack, R. Fenrich, & J. Pleune, Smooth pursuit of eye movements: Is perceived motion necessary?, *Science*, 203. Copyright 1979 by the American Association for the Advancement of Science. Reprinted by permission.
- 1.947, Fig. 2: Reprinted with permission from *Vision Research*, 18, J. D. Holtzman, H. A. Sedgwick, & L. Festinger, Interaction of perceptually monitored and unmonitored efferent commands for smooth pursuit eye movements, copyright © 1978, Pergamon Press Ltd.
- 1.947, Tab. 2: From A. Mack, R. Fenrich, & J. Pleune, Smooth pursuit of eye movements: Is perceived motion necessary?, *Science*, 203. Copyright © 1979 by the American Association for the Advancement of Science. Reprinted by permission.
- 1.948, Fig. 1: Reprinted with permission from *Vision Research*, 19, E. Kowler & R. Steinman, The effect of expectations on slow oculomotor control - I. Periodic target steps, copyright © 1979, Pergamon Journals Ltd.
- 1.951, Fig. 1: Reprinted with permission from *Vision Research*, 19, C. M. Schor, The relationship between fusional vergence eye movements and fixation disparity, copyright © 1979, Pergamon Press Ltd.
- 1.952, Fig. 1: Reprinted with permission from *Vision Research*, 9, G. Westheimer & D. E. Mitchell, The sensory stimulus for disjunctive eye movements, copyright © 1969, Pergamon Press Ltd.
- 1.953, Fig. 1: Reprinted with permission from *Vision Research*, 16, J. Semmlow & N. Venkiteswaran, Dynamic accommodative vergence components in binocular vision, copyright © 1976, Pergamon Press Ltd.
- 1.954, Fig. 1: From A. E. Kertesz & D. R. Hampton, Fusional response to extrafoveal stimulation, *Investigative Ophthalmology and Visual Science*, 1981, 21. Reprinted with permission.

- 1.954, Fig. 2: From A. E. Kertesz & D. R. Hampton, Fusional response to extrafoveal stimulation, *Investigative Ophthalmology and Visual Science*, 1981, 21. Reprinted with permission.
- 1.955, Fig. 1: Reprinted with permission from *Vision Research*, 18, A. L. Perlmutter & A. E. Kertesz, Measurement of human vertical fusional response, copyright © 1978, Pergamon Press Ltd.
- 1.955, Fig. 2: Reprinted with permission from *Vision Research*, 10, D. E. Mitchell, Properties of stimuli eliciting vergence eye movements and stereopsis, copyright © 1970, Pergamon Press Ltd.
- 1.956, Fig. 1: Reprinted with permission from *Vision Research*, 18, M. J. Sullivan & A. E. Kertesz, Binocular coordination of torsional eye movements in cyclofusional response, copyright © 1978, Pergamon Press Ltd.
- 1.959, Fig. 1: From P. Hallett, Human eye movements, in K. R. Boff, L. Kaufman, & J. P. Thomas (Eds.), *Handbook of perception and human performance: Volume I. Sensory processes and perception*. Copyright © 1986 by John Wiley & Sons, Inc. Reprinted by permission.
- 1.959, Fig. 2: Reprinted with permission from *Vision Research*, 13, A. P. Petrov & G. M. Zenkin, Torsional eye movements and constancy of the visual field, copyright © 1973, Pergamon Press Ltd.
- 2.101, Tab. 1: From *Safety engineering*, G. Marshall, Brooks/Cole Publishing, copyright © 1982. Reprinted with permission.
- 2.102, Fig. 1: From B. Scharf & S. Buus, Audition I: Stimulus, physiology, thresholds, in K. R. Boff, L. Kaufman, & J. P. Thomas (Eds.), *Handbook of perception and human performance: Volume I. Sensory processes and perception*. Copyright © 1986 by John Wiley & Sons, Inc. Reprinted with permission.
- 2.102, Fig. 2: From S. Coren, C. Porac, & L. M. Ward, *Sensation and perception*. Copyright © 1984 by Academic Press.
- 2.102, Fig. 3: From V. P. Knudsen & C. M. Harris, *Acoustical designing in architecture*. Copyright © 1950 by the American Institute of Physics. Reprinted with permission.
- 2.102, Fig. 6: From B. Scharf & S. Buus, Audition I: Stimulus, physiology, thresholds, in K. R. Boff, L. Kaufman, & J. P. Thomas (Eds.), *Handbook of perception and human performance: Volume I. Sensory processes and perception*. Copyright © 1986 by John Wiley & Sons, Inc. Reprinted with permission.
- 2.103, Tab. 1: From B. Scharf & S. Buus, Audition I: Stimulus, physiology, thresholds, in K. R. Boff, L. Kaufman, & J. P. Thomas (Eds.), *Handbook of perception and human performance: Volume I. Sensory processes and perception*. Copyright © 1986 by John Wiley & Sons, Inc. Reprinted with permission.
- 2.104, Fig. 1: From *Instrumentation and applications: Precision sound level meter type 2203/1613* (Instruction Manual), Denmark: Bruel & Kjaer Instruments, 1970. Reprinted with permission.
- 2.104, Fig. 2: From *Instruction and applications: Artificial ear type 4151* (Instruction Manual), Denmark: Bruel & Kjaer Instruments, 1961. Reprinted with permission.
- 2.201, Fig. 1: From H. W. Ades & H. Engstrom, Anatomy of the inner ear, in W. D. Keidel & W. D. Neff (Eds.), *Handbook of sensory physiology: Vol. VII. Auditory system: Anatomy, physiology (ear)*, Springer-Verlag, 1974. Reprinted with permission.
- 2.202, Fig. 1: From J. L. Fletcher & A. J. Riopelle, Protective effect of the acoustical reflex for impulsive noises, *Journal of the Acoustical Society of America*, 1960, 32. Reprinted with permission.
- 2.302, Fig. 1: From E. H. Berger, Re-examination of the low-frequency (50-1000 Hz) normal threshold of hearing in free and diffuse sound fields, *Journal of the Acoustical Society of America*, 1981, 70. Reprinted with permission.
- 2.302, Fig. 2: From B. Scharf & S. Buus, Audition I: Stimulus, physiology, thresholds, in K. R. Boff, L. Kaufman, & J. P. Thomas (Eds.), *Handbook of perception and human performance: Volume I. Sensory processes and perception*. Copyright © 1986 by John Wiley & Sons, Inc. Reprinted with permission.
- 2.302, Fig. 3: From B. Scharf & S. Buus, Audition I: Stimulus, physiology, thresholds, in K. R. Boff, L. Kaufman, & J. P. Thomas (Eds.), *Handbook of perception and human performance: Volume I. Sensory processes and perception*. Copyright © 1986 by John Wiley & Sons, Inc. Reprinted with permission.
- 2.303, Fig. 1: From R. Hinchcliffe, The threshold of hearing as a function of age, *Acustica*, 1959, 9. Reprinted with permission.
- 2.303, Tab. 1: From R. Hinchcliffe, The threshold of hearing as a function of age, *Acustica*, 1959, 9. Reprinted with permission.
- 2.304, Fig. 1: From J. F. Brandt & H. Hollien, Underwater hearing thresh-
- olds in man, *Journal of the Acoustical Society of America*, 1967, 42(5). Reprinted with permission.
- 2.305, Fig. 1: From I. J. Hirsch, Binaural summation—a century of investigation, *Psychological Bulletin*, 1948, 45.
- 2.305, Fig. 2: From B. Scharf & S. Buus, Audition I: Stimulus, physiology, thresholds, in K. R. Boff, L. Kaufman, & J. P. Thomas (Eds.), *Handbook of perception and human performance: Volume I. Sensory processes and perception*. Copyright © 1986 by John Wiley & Sons, Inc. Reprinted with permission.
- 2.305, Fig. 3: From I. J. Hirsh, The influence of interaural phase on interaural summation and inhibition, *Journal of the Acoustical Society of America*, 1948, 20. Reprinted with permission.
- 2.307, Fig. 1: From J. E. Hawkins, Jr., & S. S. Stevens, The masking of pure tones and speech by white noise, *Journal of the Acoustical Society of America*, 1950, 22. Reprinted with permission.
- 2.308, Fig. 1: From J. P. Egan & H. W. Hake, On the masking pattern of a simple auditory stimulus, *Journal of the Acoustical Society of America*, 1950, 22. Reprinted with permission.
- 2.308, Fig. 2: From J. P. Egan & H. W. Hake, On the masking pattern of a simple auditory stimulus, *Journal of the Acoustical Society of America*, 1950, 22. Reprinted with permission.
- 2.309, Fig. 2: From D. M. Green, Masking with two tones, *Journal of the Acoustical Society of America*, 1965, 37. Reprinted with permission.
- 2.309, Fig. 3: From D. A. Nelson, Two-tone masking and auditory critical bandwidths, *Audiology*, 1979, 18. Reprinted with permission.
- 2.310, Fig. 1: From B. Scharf, Critical bands, in J. V. Tobias (Ed.), *Foundations of modern auditory theory*. Copyright © 1970 by Academic Press. Reprinted with permission.
- 2.312, Fig. 1: From H. Fastl, Temporal masking effects: II. Critical band noise maker, *Acustica*, 1976/77, 36. Reprinted with permission.
- 2.312, Fig. 2: From H. N. Wright, Temporal summation and backward masking, *Journal of the Acoustical Society of America*, 1964, 36. Reprinted with permission.
- 2.313, Fig. 1: From J. J. Zwillocki, E. N. Damianopoulos, E. Buining, & J. Giantz, Central masking: Some steady-state and transient effects, *Perception and Psychophysics*, 1967, 2. Reprinted with permission.
- 2.314, Fig. 1: From I. J. Hirsh & M. Burgeat, Binaural effects in remote masking, *Journal of the Acoustical Society of America*, 1958, 30. Reprinted with permission.
- 2.314, Fig. 2: From I. J. Hirsh & M. Burgeat, Binaural effects in remote masking, *Journal of the Acoustical Society of America*, 1958, 30. Reprinted with permission.
- 2.315, Fig. 1: From L. A. Jeffress, H. C. Blodgett, & B. H. Deatherage, Masking and interaural phase. II. 167 cycles, *Journal of the Acoustical Society of America*, 1962, 34. Reprinted with permission. and From L. A. Jeffress, H. C. Blodgett, & B. H. Deatherage, Masking of tones by white noise as a function of the interaural phases of both components. I. 500 cycles, *Journal of the Acoustical Society of America*, 1952, 24. Reprinted with permission.
- 2.401, Fig. 1: From G. A. Miller, Sensitivity to changes in the intensity of white noise and its relation to masking and loudness, *Journal of the Acoustical Society of America*, 1947, 19(6). Reprinted with permission.
- 2.501, Fig. 1: From N. F. Viemeister, Temporal modulation transfer functions based upon modulation thresholds, *Journal of the Acoustical Society of America*, 1979, 66(5). Reprinted with permission.
- 2.502, Fig. 1: From M. Florentine & S. Buus, Temporal acuity as a function of level and frequency, *Proceedings of the 11th International Congress on Acoustics*, 1983, 3. Reprinted with permission.
- 2.503, Fig. 1: From S. M. Abel, Discrimination of temporal gaps, *Journal of the Acoustical Society of America*, 1972, 52. Reprinted with permission.
- 2.503, Fig. 2: From S. M. Abel, Duration discrimination of noise and tone bursts, *Journal of the Acoustical Society of America*, 1972, 51. Reprinted with permission.
- 2.602, Fig. 1: From B. Scharf & A. J. M. Houtsma, Audition II: Loudness, pitch, localization, aural distortion, pathology, in K. R. Boff, L. Kaufman, & J. P. Thomas (Eds.), *Handbook of perception and human performance: Volume I. Sensory processes and perception*. Copyright © 1986 by John Wiley & Sons, Inc. Reprinted with permission.
- 2.602, Fig. 2: From B. Scharf & D. Fishken, Binaural summation of loudness: Reconsidered, *Journal of Experimental Psychology*, 86. Copyright © 1970 by the American Psychological Association. Reprinted by permission of the publisher and author.

- 2.603, Fig. 1: From B. Scharf & A. J. M. Houtsma, Audition II: Loudness, pitch, localization, aural distortion, pathology, in K. R. Boff, L. Kaufman, & J. P. Thomas (Eds.), *Handbook of perception and human performance: Volume I. Sensory processes and perception*. Copyright © 1986 by John Wiley & Sons, Inc. Reprinted with permission.
- 2.603, Fig. 2: From D. W. Robinson & R. S. Dadson, A re-determination of the equal-loudness relations for pure tones, *British Journal of Applied Physics*, 1956, 7. Reprinted with permission.
- 2.603, Fig. 3: From B. Scharf, Loudness, in E. C. Carterette & M. P. Friedman (Eds.), *Handbook of perception, Vol. 4: Hearing*. Copyright © 1978 by Academic Press, Inc. Reprinted with permission.
- 2.604, Fig. 1: From B. Scharf, Critical bands, in J. V. Tobias (Ed.), *Foundations of modern auditory theory (Vol. 1)*. Copyright © 1970 by Academic Press, Inc. Reprinted with permission.
- 2.605, Fig. 1: From J. C. R. Licklider, Basic correlates of the auditory stimulus, in S. S. Stevens (Ed.), *Handbook of experimental psychology*. Copyright © 1951 by John Wiley & Sons, Inc. Reprinted by permission.
- 2.606, Fig. 1: From E. Zwicker & R. Feldtkeller, Über die Lautstärke von gleichförmigen Geräuschen, *Acustica*, 1955, 5. Reprinted with permission.
- 2.607, Fig. 1: From E. Port, Über die Lautstärke einzelner kurzer Schallimpulse, *Acustica*, 1963, 13. Reprinted with permission.
- 2.607, Tab. 1: From B. Scharf, Loudness, in E. C. Carterette & M. P. Friedman (Eds.), *Handbook of perception Vol. 4: Hearing*. Copyright © 1978 by Academic Press, Inc. Reprinted with permission.
- 2.608, Fig. 1: From B. Scharf & D. Fishken, Binaural summation of loudness: Reconsidered, *Journal of Experimental Psychology*, 86(3). Copyright © 1970 by the American Psychological Association. Reprinted by permission of the publisher and author.
- 2.609, Fig. 1: From I. J. Hirsh & I. Pollack, The role of interaural phase in loudness, *Journal of the Acoustical Society of America*, 1948, 20. Reprinted with permission.
- 2.609, Fig. 2: From I. J. Hirsh & I. Pollack, The role of interaural phase in loudness, *Journal of the Acoustical Society of America*, 1948, 20. Reprinted with permission.
- 2.611, Fig. 1: From B. Scharf, Patterns of partial masking, *Proceedings of the 7th International Congress on Acoustics*, 1971, 3. Reprinted with permission.
- 2.611, Fig. 2: From B. Scharf, Loudness, in E. C. Carterette & M. P. Friedman (Eds.), *Handbook of perception Vol. 4: Hearing*. Copyright © 1978 by Academic Press, Inc. Reprinted with permission.
- 2.612, Fig. 1: From B. Scharf, Loudness adaptation, in J. V. Tobias & E. D. Schubert (Eds.), *Hearing research and theory*. Copyright © 1983 by Academic Press, Inc. Reprinted with permission.
- 2.612, Fig. 2: From B. Scharf & A. J. M. Houtsma, Audition II: Loudness, pitch, localization, aural distortion, pathology, in K. R. Boff, L. Kaufman, & J. P. Thomas (Eds.), *Handbook of perception and human performance: Volume I. Sensory processes and perception*. Copyright © 1986 by John Wiley & Sons, Inc. Reprinted with permission.
- 2.613, Fig. 1: From D. E. Morgan, R. H. Wilson, & D. D. Dirks, Loudness discomfort level: Selected methods and stimuli, *Journal of the Acoustical Society of America*, 1974, 56. Reprinted with permission.
- 2.702, Fig. 1: From S. S. Stevens & J. Volkman, The relation of pitch to frequency: A revised scale, *American Journal of Psychology*, 53. Copyright © 1940 by the University of Illinois Press. Reprinted with permission.
- 2.703, Fig. 1: From E. Terhardt & H. Fastl, Zum Einfluss von Störtonen und Störgeräuschen auf die Tonhöhe von Sinustönen, *Acustica*, 1971, 25. Reprinted with permission.
- 2.703, Fig. 2: From E. Terhardt & H. Fastl, Zum Einfluss von Störtonen und Störgeräuschen auf die Tonhöhe von Sinustönen, *Acustica*, 1971, 25. Reprinted with permission.
- 2.704, Fig. 1: From D. Deutsch & J. Feroe, Disinhibition in pitch memory, *Perception and Psychophysics*, 1975, 17. Reprinted with permission.
- 2.705, Fig. 1: From B. Scharf & A. Houtsma, Audition II: Loudness, pitch, localization, aural distortion, pathology, in K. R. Boff, L. Kaufman, & J. P. Thomas (Eds.), *Handbook of perception and human performance: Volume I. Sensory processes and perception*. Copyright © 1986 by John Wiley & Sons, Inc. Reprinted with permission.
- 2.706, Fig. 1: From C. T. Morgan, *Physiological psychology*. Copyright © 1943 by McGraw-Hill Book Co. Reprinted with permission.
- 2.707, Fig. 1: From W. D. Larkin, Pitch shifts following tone adaptation, *Acustica*, 1978, 41. Reprinted with permission.
- 2.708, Fig. 1: From R. A. Rasch, The perception of simultaneous notes such as in polyphonic music, *Acustica*, 1978, 40. Reprinted with permission.
- 2.708, Fig. 2: From D. Deutsch, Auditory pattern recognition, in K. R. Boff, L. Kaufman, & J. P. Thomas (Eds.), *Handbook of perception and human performance: Volume II. Cognitive processes and performance*. Copyright © 1986 by John Wiley & Sons, Inc. Reprinted with permission.
- 2.709, Fig. 1: From R. A. Rasch, The perception of simultaneous notes such as in polyphonic music, *Acustica*, 1978, 40. Reprinted with permission.
- 2.709, Fig. 2: From R. A. Rasch, The perception of simultaneous notes such as in polyphonic music, *Acustica*, 1978, 40. Reprinted with permission.
- 2.709, Fig. 3: From R. A. Rasch, The perception of simultaneous notes such as in polyphonic music, *Acustica*, 1978, 40. Reprinted with permission.
- 2.709, Fig. 4: From R. A. Rasch, The perception of simultaneous notes such as in polyphonic music, *Acustica*, 1978, 40. Reprinted with permission.
- 2.711, Fig. 1: From G. A. Miller & W. G. Taylor, The perception of repeated bursts of noise, *Journal of the Acoustical Society of America*, 1948, 20. Reprinted with permission.
- 2.711, Fig. 2: From G. A. Miller & W. G. Taylor, The perception of repeated bursts of noise, *Journal of the Acoustical Society of America*, 1948, 20. Reprinted with permission.
- 2.802, Fig. 1: From E. A. G. Shaw, Transformation of sound pressure level from the free field to the eardrum in the horizontal plane, *Journal of the Acoustical Society of America*, 1974, 56. Reprinted with permission.
- 2.802, Fig. 2: From E. A. G. Shaw, Transformation of sound pressure level from the free field to the eardrum in the horizontal plane, *Journal of the Acoustical Society of America*, 1974, 56. Reprinted with permission.
- 2.803, Fig. 1: From W. E. Feddersen, T. T. Sandel, D. C. Teas, & L. A. Jeffress, Localization of high-frequency tones, *Journal of the Acoustical Society of America*, 1957, 29. Reprinted with permission.
- 2.804, Fig. 1: From A. W. Mills, Lateralization of high-frequency tones, *Journal of the Acoustical Society of America*, 1960, 32. Reprinted with permission.
- 2.804, Tab. 1: From B. Scharf & A. J. M. Houtsma, Audition II: Loudness, pitch, localization, aural distortion, pathology, in K. R. Boff, L. Kaufman, & J. P. Thomas (Eds.), *Handbook of perception and human performance: Volume I. Sensory processes and perception*. Copyright © 1986 by John Wiley & Sons, Inc. Reprinted with permission.
- 2.805, Fig. 1: From N. I. Durlach & H. S. Colburn, Binaural phenomena, in E. C. Carterette & M. P. Friedman (Eds.), *Handbook of perception Vol. IV: Hearing*. Copyright © 1978 by Academic Press. Reprinted with permission.
- 2.805, Fig. 2: From J. Blauert, *Spatial hearing: The psychophysics of human sound localization*. Copyright © 1983 by MIT Press. Reprinted with permission.
- 2.806, Fig. 1: From A. W. Mills, Lateralization of high-frequency tones, *Journal of the Acoustical Society of America*, 1960, 32. Reprinted with permission.
- 2.807, Fig. 1: From J. Blauert, *Spatial hearing: The psychophysics of human sound localization*. Copyright © 1983 by MIT Press. Reprinted with permission.
- 2.808, Fig. 1: From G. B. Henning, Detectability of interaural delay in high-frequency complex waveform, *Journal of the Acoustical Society of America*, 1974, 55(1). Reprinted with permission.
- 2.809, Fig. 1: From E. E. David, N. Guttman, & W. A. van Bergeijk, Binaural interaction of high-frequency complex stimuli, *Journal of the Acoustical Society of America*, 1959, 31. Reprinted with permission.
- 2.810, Fig. 1: From J. Blauert, *Spatial hearing: The psychophysics of human sound localization*. Copyright © 1983 by MIT Press. Reprinted with permission.
- 2.810, Fig. 2: From S. K. Roffler & R. A. Butler, Factors that influence the localization of sound in the vertical plane, *Journal of the Acoustical Society of America*, 1968, 43(6). Reprinted with permission.
- 2.811, Fig. 1: From E. R. Hafter, R. H. Dye, & R. H. Gilkey, Lateralization of tonal signals which have neither onsets nor offsets, *Journal of the Acoustical Society of America*, 1979, 65(2). Reprinted with permission.
- 2.812, Fig. 1: From A. W. Mills, Auditory perception of spatial relations, *Proceedings of the International Congress on Technology and Blindness: Vol. II*, 1963. Reprinted with permission from the American Foundation for the Blind.

- 2.814, Fig. 1: From J. R. Lackner, The role of posture in sound localization, *Quarterly Journal of Experimental Psychology*, 1973, 26. Experimental Psychology Society. Reprinted with permission.
- 2.814, Fig. 2: From J. R. Lackner, The role of posture in sound localization, *Quarterly Journal of Experimental Psychology*, 1973, 26. Experimental Psychology Society. Reprinted with permission.
- 2.815, Fig. 1: From D. H. Warren, Intermodality interactions in spatial localization, *Cognitive Psychology*, 1. Copyright © 1970 by Academic Press, Inc. Reprinted with permission.
- 2.815, Fig. 2: From D. H. Warren, Intermodality interactions in spatial localization, *Cognitive Psychology*, 1. Copyright © 1970 by Academic Press, Inc. Reprinted with permission.
- 2.817, Fig. 1: From H. Wallach, E. B. Newman, & M. R. Rosenweig, The precedence effect in sound localization, *American Journal of Psychology*, 1949, 62. Reprinted with permission.
- 2.817, Fig. 2: From H. Wallach, E. B. Newman, & M. R. Rosenweig, The precedence effect in sound localization, *American Journal of Psychology*, 1949, 62. Reprinted with permission.
- 2.817, Fig. 3: From H. Wallach, E. B. Newman, & M. R. Rosenweig, The precedence effect in sound localization, *American Journal of Psychology*, 1949, 62. Reprinted with permission.
- 3.102, Fig. 1: From C. E. Sherrick & R. W. Cholewiak, Cutaneous sensitivity, in K. R. Boff, L. Kaufman, & J. P. Thomas (Eds.), *Handbook of perception and human performance: Volume 1. Sensory processes and perception*. Copyright © 1986 by John Wiley & Sons, Inc. Reprinted with permission.
- 3.102, Fig. 2: From C. E. Sherrick & R. W. Cholewiak, Cutaneous sensitivity, in K. R. Boff, L. Kaufman, & J. P. Thomas (Eds.), *Handbook of perception and human performance: Volume 1. Sensory processes and perception*. Copyright © 1986 by John Wiley & Sons, Inc. Reprinted with permission.
- 3.103, Fig. 1: From C. E. Sherrick & R. W. Cholewiak, Cutaneous sensitivity, in K. R. Boff, L. Kaufman, & J. P. Thomas (Eds.), *Handbook of perception and human performance: Volume 1. Sensory processes and perception*. Copyright © 1986 by John Wiley & Sons, Inc. Reprinted with permission.
- 3.103, Fig. 2: From C. E. Sherrick & R. W. Cholewiak, Cutaneous sensitivity, in K. R. Boff, L. Kaufman, & J. P. Thomas (Eds.), *Handbook of perception and human performance: Volume 1. Sensory processes and perception*. Copyright © 1986 by John Wiley & Sons, Inc. Reprinted with permission.
- 3.104, Tab. 1: From K. W. Horch, R. P. Tuckett, & P. R. Burgess, A key to the classification of cutaneous mechanoreceptors, *Journal of Investigative Dermatology*, 1979, 69.
- 3.107, Fig. 1: From J. W. Hill, *The perception of multiple tactile stimuli*, Tech. Rep. 4823-1, Stanford Electronics Laboratories, Stanford University, 1967. Reprinted with permission.
- 3.108, Fig. 1: From C. E. Sherrick & R. W. Cholewiak, Cutaneous sensitivity, in K. R. Boff, L. Kaufman, & J. P. Thomas (Eds.), *Handbook of perception and human performance: Volume 1. Sensory processes and perception*. Copyright © 1986 by John Wiley & Sons, Inc. Reprinted with permission.
- 3.109, Fig. 1: From C. E. Sherrick & R. W. Cholewiak, Cutaneous sensitivity, in K. R. Boff, L. Kaufman, & J. P. Thomas (Eds.), *Handbook of perception and human performance: Volume 1. Sensory processes and perception*. Copyright © 1986 by John Wiley & Sons, Inc. Reprinted with permission.
- 3.110, Fig. 1: From J. C. Craig, Vibrotactile difference thresholds for intensity and the effect of a masking stimulus, *Perception and Psychophysics*, 15. Copyright © 1974 by the Psychonomic Society. Reprinted with permission.
- 3.111, Fig. 1: From R. T. Verrillo & S. C. Chamberlain, Effect of neural density and contractor surround on vibrotactile sensation magnitude, *Perception and Psychophysics*, 11. Copyright © 1972 by the Psychonomic Society. Reprinted with permission.
- 3.112, Fig. 1: From R. W. Cholewiak, Spatial factors in the perceived intensity of vibrotactile patterns, *Sensory Processes*, 3. Copyright © 1979 by Academic Press. Reprinted with permission.
- 3.113, Fig. 1: From R. T. Verrillo & G. A. Gescheider, Enhancement and summation in two successive vibrotactile stimuli, *Perception and Psychophysics*, 18(2). Copyright 1975 by the Psychonomic Society. Reprinted with permission.
- 3.114, Fig. 1: (a) From R. T. Verrillo & G. A. Gescheider, Enhancement and summation in two successive vibrotactile stimuli, *Perception and Psychophysics*, 18(2). Copyright © 1975 by the Psychonomic Society. Reprinted with permission. (b) From R. T. Verrillo & G. A. Gescheider, Enhancement and summation in two successive vibrotactile stimuli, *Perception and Psychophysics*, 18(2). Copyright © 1975 by the Psychonomic Society. Reprinted with permission.
- 3.116, Fig. 1: From J. F. Hahn, Vibrotactile adaptation and recovery measured by two methods, *Journal of Experimental Psychology*, 71. Copyright © 1966 by the American Psychological Association. Reprinted with permission.
- 3.117, Fig. 1: From C. E. Sherrick, Effects of double simultaneous stimulation of the skin, *American Journal of Psychology*, 77. Copyright © 1964 by the University of Illinois Press. Reprinted with permission.
- 3.118, Fig. 1: From G. von Békésy, *Experiments in hearing*. Copyright © 1960 by McGraw-Hill. Reprinted with permission.
- 3.119, Fig. 1: From C. E. Sherrick & R. W. Cholewiak, Cutaneous sensitivity, in K. R. Boff, L. Kaufman, & J. P. Thomas (Eds.), *Handbook of perception and human performance: Volume 1. Sensory processes and perception*. Copyright © 1986 by John Wiley & Sons, Inc. Reprinted with permission.
- 3.120, Fig. 1: From C. E. Sherrick & R. W. Cholewiak, Cutaneous sensitivity, in K. R. Boff, L. Kaufman, & J. P. Thomas (Eds.), *Handbook of perception and human performance: Volume 1. Sensory processes and perception*. Copyright © 1986 by John Wiley & Sons, Inc. Reprinted with permission.
- 3.121, Fig. 1: From D. R. Kenshalo, T. Deckér, & A. Hamilton, Spatial summation on the forehead, forearm, and back produced by radiant and conducted heat, *Journal of Comparative and Physiological Psychology*, 63. Copyright © 1967 by the American Psychological Association. Reprinted by permission of the publisher.
- 3.122, Fig. 1: From D. R. Kenshalo, C. E. Holmes, & P. B. Wood, Warm and cool thresholds as a function of rate of stimulus temperature change, *Perception and Psychophysics*, 3(2A). Copyright © 1968 by the Psychonomic Society. Reprinted with permission.
- 3.123, Fig. 1: From D. R. Kenshalo, Psychophysical studies of temperature sensitivity, in W. D. Neff (Ed.), *Contributions to sensory physiology*. Copyright © 1970 by Academic Press. Reprinted with permission.
- 3.124, Fig. 1: From L. E. Marks & J. C. Stevens, Perceived cold and skin temperature as a function of stimulation level and duration, *American Journal of Psychology*, 85. Copyright © 1972 by the University of Illinois Press. Reprinted with permission.
- 3.125, Fig. 1: From C. E. Sherrick & R. W. Cholewiak, Cutaneous sensitivity, in K. R. Boff, L. Kaufman, & J. P. Thomas (Eds.), *Handbook of perception and human performance: Volume 1. Sensory processes and perception*. Copyright © 1986 by John Wiley & Sons, Inc. Reprinted with permission.
- 3.201, Fig. 1: From I. P. Howard, The vestibular system, in K. R. Boff, L. Kaufman, & J. P. Thomas (Eds.), *Handbook of perception and human performance: Volume 1. Sensory processes and perception*. Copyright © 1986 by John Wiley & Sons, Inc. Reprinted with permission.
- 3.201, Fig. 2: From H. H. Lindeman, Studies on the morphology of the sensory regions of the vestibular apparatus, *Ergebnisse der Anatomie*, 1969, 42.
- 3.201, Fig. 3: From A. J. Benson, The vestibular sensory system, in H. B. Barlow & J. D. Mollon (Eds.), *The senses*. Cambridge University Press, 1982. Reprinted with permission.
- 3.201, Fig. 4: From H. Engstrom, B. Bergstrom, & H. W. Ades, Macula utriculi and macula sacculi in the squirrel monkey, *Acta Otolaryngologica*, 1972, 301 (Suppl.). Reprinted with permission.
- 3.202, Fig. 1: From R. Malcolm & G. Melvill Jones, A quantitative study of vestibular adaptation in humans, *Acta Otolaryngologica*, 1970, 70. Reprinted with permission.
- 3.202, Fig. 2: From S. Iurato, Light microscope features, in S. Iurato (Ed.), *Submicroscopic structure of the inner ear*. Copyright © 1967 by Pergamon Press, Ltd. Reprinted with permission.
- 3.202, Fig. 3: From A. J. Benson, The vestibular system, in H. B. Barlow & J. D. Mollon (Eds.), *The senses*. Copyright © 1982 by Cambridge University Press. Reprinted with permission.
- 3.204, Fig. 1: From J. J. Groen, The problems of the spinning top applied to the semi-circular canals, *Confinia Neurologica*, 21. Copyright © 1961 by S. Karger AG, Basel. Reprinted with permission.
- 3.204, Tab. 1: From J. J. Groen, The problems of the spinning top applied to the semi-circular canals, *Confinia Neurologica*, 21. Copyright 1961 by S. Karger AG, Basel. Reprinted with permission.

- 3.205, Fig. 1: From L. B. W. Jongkees, On the physiology and examination of the vestibular labyrinths, in R. F. Naunton (Ed.), *The vestibular system*. Copyright © 1975 by Academic Press, Inc. Reprinted with permission.
- 3.205, Fig. 2: From I. P. Howard, The vestibular system, in K. R. Boff, L. Kaufman, & J. P. Thomas (Eds.), *Handbook of perception and human performance: Volume 1. Sensory processes and perception*. Copyright © 1986 by John Wiley & Sons, Inc. Reprinted with permission.
- 3.206, Fig. 1: From L. B. W. Jongkees, On the physiology and examination of the vestibular labyrinths, in R. F. Naunton (Ed.), *The vestibular system*. Copyright © 1975 by Academic Press, Inc. Reprinted with permission.
- 3.207, Fig. 1: From G. Melvill Jones & L. R. Young, Subjective detection of vertical acceleration: A velocity-dependent response, *Acta Otolaryngologica*, 1978, 85. Reprinted with permission.
- 3.207, Tab. 1: From I. P. Howard, The vestibular system, in K. R. Boff, L. Kaufman, & J. P. Thomas (Eds.), *Handbook of perception and human performance: Volume 1. Sensory processes and perception*. Copyright © 1986 by John Wiley & Sons, Inc. Reprinted with permission.
- 3.208, Fig. 1: From F. E. Guedry, Psychophysics of vestibular sensation, in H. H. Kornhuber (Ed.), *Handbook of sensory physiology (Vol. VII2)*, Springer-Verlag, 1974. Reprinted with permission.
- 3.208, Tab. 1: From I. P. Howard, The vestibular system, in K. R. Boff, L. Kaufman, & J. P. Thomas (Eds.), *Handbook of perception and human performance: Volume 1. Sensory processes and perception*. Copyright © 1986 by John Wiley & Sons, Inc. Reprinted with permission.
- 3.210, Tab. 1: From I. P. Howard, The perception of posture, self-motion, and the visual vertical, in K. R. Boff, L. Kaufman, & J. P. Thomas (Eds.), *Handbook of perception and human performance: Volume 1. Sensory processes and perception*. Copyright © 1986 by John Wiley & Sons, Inc. Reprinted with permission.
- 3.304, Tab. 1: From F. J. Clark & K. W. Horch, Kinesthesia, in K. R. Boff, L. Kaufman, & J. P. Thomas (Eds.), *Handbook of perception and human performance: Volume 1. Sensory processes and perception*. Copyright © 1986 by John Wiley & Sons, Inc. Reprinted with permission.
- 3.304, Tab. 2: From F. J. Clark & K. W. Horch, Kinesthesia, in K. R. Boff, L. Kaufman, & J. P. Thomas (Eds.), *Handbook of perception and human performance: Volume 1. Sensory processes and perception*. Copyright © 1986 by John Wiley & Sons, Inc. Reprinted with permission.
- 3.304, Tab. 3: From F. J. Clark & K. W. Horch, Kinesthesia, in K. R. Boff, L. Kaufman, & J. P. Thomas (Eds.), *Handbook of perception and human performance: Volume 1. Sensory processes and perception*. Copyright © 1986 by John Wiley & Sons, Inc. Reprinted with permission.
- 3.305, Fig. 1: From L. A. Hall & D. I. McCloskey, Detection of movements imposed on finger, elbow, and shoulder joints, *Journal of Physiology*, 335. Copyright © 1983 by Cambridge University Press. Reprinted with permission.
- 3.305, Fig. 2: From L. A. Hall & D. I. McCloskey, Detection of movements imposed on finger, elbow, and shoulder joints, *Journal of Physiology*, 335. Copyright © 1983 by Cambridge University Press. Reprinted with permission.
- 3.305, Fig. 3: From L. A. Hall & D. I. McCloskey, Detection of movements imposed on finger, elbow, and shoulder joints, *Journal of Physiology*, 335. Copyright © 1983 by Cambridge University Press. Reprinted with permission.
- 3.306, Fig. 1: From J. Grigg, G. A. Finerman, & L. H. Riley, Joint-position sense after total hip replacement, *Journal of Bone and Joint Surgery*, 1973, 55-A. Reprinted with permission.
- 3.307, Fig. 1: From S. C. Gandevia & D. I. McCloskey, Joint sense, muscle sense, and their combination as position sense, measured at the distal interphalangeal joint at the middle finger, *Journal of Physiology*, 260. Copyright © 1976 by Cambridge University Press. Reprinted with permission.
- 3.308, Tab. 1: From F. J. Clark & K. W. Horch, Kinesthesia, in K. R. Boff, L. Kaufman, & J. P. Thomas (Eds.), *Handbook of perception and human performance: Volume 1. Sensory processes and perception*. Copyright © 1986 by John Wiley & Sons, Inc. Reprinted with permission.
- 3.309, Fig. 1: From F. J. Clark & K. W. Horch, Kinesthesia, in K. R. Boff, L. Kaufman, & J. P. Thomas (Eds.), *Handbook of perception and human performance: Volume 1. Sensory processes and perception*. Copyright © 1986 by John Wiley & Sons, Inc. Reprinted with permission.
- 3.310, Fig. 1: From B. Kraske & M. Crawshaw, Differential errors of kinesthesia produced by previous limb position, *Journal of Motor Behavior*, 6, 1974. Reprinted with permission of the Helen Dwight Reid Educational Foundation. Published by Heldref Publications. Copyright © 1974.
- 3.311, Fig. 1: From J. Paillard & M. Brouchon, Active and passive movements in the calibration of position sense, in S. J. Freedman (Ed.), *The neuropsychology of spatially oriented behavior*, Dorsey Press, 1968. Reprinted with permission.
- 3.311, Fig. 2: From J. Paillard & M. Brouchon, Active and passive movements in the calibration of position sense, in S. J. Freedman (Ed.), *The neuropsychology of spatially oriented behavior*, Dorsey Press, 1968. Reprinted with permission.
- 3.312, Fig. 1: From J. Paillard & M. Brouchon, Active and passive movements in the calibration of position sense, in S. J. Freedman (Ed.), *The neuropsychology of spatially oriented behavior*, Dorsey Press, 1968. Reprinted with permission.
- 3.312, Fig. 2: From J. Paillard & M. Brouchon, A proprioceptive contribution to the spatial encoding of position cues for ballistic movements, *Brain Research*, 1974, 71. Reprinted with permission.
- 3.313, Fig. 1: From J. F. Soechting, Does position sense at the elbow reflect a sense of elbow joint angle or one of limb orientation? *Brain Research*, 248. Copyright © 1982 by Elsevier Science Publishers B. V. Reprinted with permission.
- 3.313, Fig. 2: From J. F. Soechting, Does position sense at the elbow reflect a sense of elbow joint angle or one of limb orientation? *Brain Research*, 248. Copyright © 1982 by Elsevier Science Publishers B. V. Reprinted with permission.
- 3.314, Fig. 1: From D. I. McCloskey, Kinesthetic sensations and motor commands in man, in J. E. Desmedt (Ed.), *Progress in clinical neurophysiology (Vol. 8)*, S. Karger, 1980. Reprinted with permission.
- 3.314, Fig. 2: From R. P. Erickson, Parallel population neural coding feature extraction, in F. O. Schmitt & F. G. Worden (Eds.), *The neurosciences third study program*. Copyright © 1974, MIT Press.
- 3.314, Tab. 1: From F. J. Clark & K. W. Horch, Kinesthesia, in K. R. Boff, L. Kaufman, & J. P. Thomas (Eds.), *Handbook of perception and human performance: Volume 1. Sensory processes and perception*. Copyright © 1986 by John Wiley & Sons, Inc. Reprinted with permission.
- 3.315, Fig. 1: From D. I. McCloskey, Differences between the senses of movement and position shown by the effects of loading and vibration of muscles in man, *Brain Research*, 1973, 63. Reprinted with permission.
- 3.316, Fig. 1: From L. A. Cohen, Analysis of position sense in human shoulder, *Journal of Neurophysiology*, 1958, 21. Reprinted with permission.
- 3.317, Fig. 1: From F. J. Clark & K. W. Horch, Kinesthesia, in K. R. Boff, L. Kaufman, & J. P. Thomas (Eds.), *Handbook of perception and human performance: Volume 1. Sensory processes and perception*. Copyright © 1986 by John Wiley & Sons, Inc. Reprinted with permission.
- 3.318, Fig. 1: From W. Z. Rymer & A. D'Almeida, Joint position sense: The effects of muscle contraction, *Brain*, 103. Copyright © 1980 by Oxford University Press. Reprinted with permission.
- 3.318, Fig. 2: From W. Z. Rymer & A. D'Almeida, Joint position sense: The effects of muscle contraction, *Brain*, 103. Copyright © 1980 by Oxford University Press. Reprinted with permission.
- 3.318, Fig. 3: From W. Z. Rymer & A. D'Almeida, Joint position sense: The effects of muscle contraction, *Brain*, 103. Copyright © 1980 by Oxford University Press. Reprinted with permission.
- 3.319, Fig. 1: From A. J. Lloyd & L. S. Caldwell, Accuracy of active and passive positioning of the leg on the basis of kinesthetic cues, *Journal of Comparative and Physiological Psychology*, 60. Copyright © 1965 by the American Psychological Association. Reprinted by permission of the publisher and author.
- 3.319, Fig. 2: From F. J. Clark, K. W. Horch, S. M. Bach, & G. F. Larson, Contribution of cutaneous and joint receptors to static knee-position sense in man, *Journal of Neurophysiology*, 1979, 42. Reprinted with permission.
- 3.320, Fig. 1: From A. W. Monster, R. Herman, & N. R. Altland, Effect of the peripheral and central sensory component in the calibration of position, *New developments in electromyography and clinical neurophysiology*. Copyright © 1973 by S. Karger AG, Basel. Reprinted with permission.
- 3.320, Fig. 2: From A. W. Monster, R. Herman, & N. R. Altland, Effect of the peripheral and central sensory component in the calibration of position, *New developments in electromyography and clinical neurophysiology*. Copyright © 1973 by S. Karger AG, Basel. Reprinted with permission.
- 3.322, Fig. 1: From S. Skoglund, Anatomical and physiological studies of knee joint innervation in the cat, *Acta Physiologica Scandinavica*, 1956, 36. Reprinted with permission.

3.322, Fig. 2: From V. B. Mountcastle, G. F. Poggio, & G. Werner, The relation of thalamic cell response to peripheral stimuli varied over an intensive continuum, *Journal of Neurophysiology*, 1963, 26. Reprinted with permission.

3.323, Fig. 1: From D. I. McCloskey, P. Ebeling, & G. M. Goodwin, Estimation of weights and tensions and apparent involvement of a sense of effort, *Experimental Neurology*, 42. Copyright © 1974 by Academic Press. Reprinted with permission.

3.324, Fig. 1: From S. C. Gandevia & D. I. McCloskey, Effects of related sensory inputs on motor performances in man studied through changes in perceived heaviness, *Journal of Physiology*, 1977, 272. Reprinted with permission.

3.324, Fig. 2: From S. C. Gandevia & D. I. McCloskey, Effects of related sensory inputs on motor performances in man studied through changes in perceived heaviness. *Journal of Physiology*, 1977, 272. Reprinted with permission.

3.324, Fig. 3: From S. C. Gandevia & D. I. McCloskey, Effects of related sensory inputs on motor performances in man studied through changes in perceived heaviness, *Journal of Physiology*, 1977, 272. Reprinted with permission.

3.325, Fig. 1: From D. I. McCloskey, P. Ebeling, & G. M. Goodwin, Estimation of weights and tensions and apparent involvement of a "sense of effort," *Experimental Neurology*, 42. Copyright © 1974 by Academic Press. Reprinted with permission.

3.325, Fig. 2: From P. E. Roland & H. Ladegaard-Pedersen, A quantitative analysis of sensations of tension and of kinesthesia in man: Evidence for a peripherally originating muscular sense and for a sense of effort, *Brain*, 100. Copyright © 1977 by Oxford University Press. Reprinted with permission.

3.325, Fig. 3: From P. E. Roland & H. Ladegaard-Pedersen, A quantitative analysis of sensations of tension and of kinesthesia in man: Evidence for a peripherally originating muscular sense and for a sense of effort, *Brain*, 100. Copyright © 1977 by Oxford University Press. Reprinted with permission.

3.326, Fig. 1: From F. A. Hellebrandt, S. P. Houtz, M. J. Partridge, & C. E. Walters, Tonic neck reflexes in exercise of stress in man, *American Journal of Physical Medicine*, 35. Copyright © 1956 by Williams & Wilkins. Reprinted with permission.

Introduction

In science, by a fiction as remarkable as any to be found in law, what has once been published, even though it be in the Russian language, is spoken of as known, and it is too often forgotten that the rediscovery in the library may be a more difficult and uncertain process than the first discovery in the laboratory.

Lord Rayleigh (1884)

Despite spectacular advances in display systems and data handling technologies, modern crew systems confront their operators with a staggering volume of codified information that competes for scarce attentional and control resources. Unabated, these increasing psychological and physiological demands have the potential to undermine critical technology gains in system performance. While it is generally accepted that the ability of the human operator to acquire and process task-critical information is a key contributor to system effectiveness, significant difficulties arise in translating this realization into meaningful action in system design and acquisition. Recognition of the problem has spurred concerted efforts across the Department of Defense to influence early design tradeoffs in favor of an improved match between system specifications and operator characteristics.

Whether or not an optimal fit will be achieved between system capabilities and the perceptual and performance capabilities of the operator depends, among other things, on the nature of the design process, the inclinations and biases of designers, and the availability of usable data resources. In particular, human performance data are needed in a form and at a level of precision that will allow operator characteristics to be traded off against other design variables (Ref. 1).

While a good deal of potentially useful human performance data exist, these data have had very little direct impact on the design of system interfaces. In large measure, this failure to translate relevant research findings into practice is due to the perceived high costs and risks associated with their *accessibility*, *interpretability*, and *applicability* for system design problems.

Accessibility. Much of the research data of potential value to system designers is embedded in the huge volume of psychological and technical literature distributed among countless journals, periodicals, and government and industrial reports. Furthermore, the contextual and theoretical framework within which researchers typically generate and disseminate technical information does not necessarily coincide with the logical framework or needs of the practitioner. Designers may not readily locate the information they need in the places they expect to find it (Ref. 2).

Interpretability. The difficulty of the nonspecialist in understanding and evaluating the technical data found in traditional sources of ergonomics information is also a major problem. Researchers typically feel little responsibility to the applied world beyond reporting their findings in the scientific literature. Hence, interpreting scientific communications generally adds considerable overhead and in fact may be a barrier for the practitioner who lacks the ability to evaluate the relevance of ergonomics information to the problem at hand (Ref. 3). The human factors profession is particularly guilty of failing to tailor the presentation of human perception and performance data to the needs of practitioners (Ref. 4).

Applicability. A major problem influencing the use of ergonomics data is the obvious difficulty and continuing controversy regarding the relevance and translatability of research data to practice (Refs. 5, 6). Not only are data collected under highly controlled circumstances, but the experimental conditions set by researchers are often so synthetic that a major stretch of the imagination is required to find analogous circumstances in the real world to which these conditions might relate. The concern is that data collected under such highly limiting conditions cannot be reasonably extrapolated to multivariate environments where it is difficult to take account of the many interacting factors that may contribute to performance variability. Unfortunately, this criticism is also true of most applied multivariate studies in which the problems of comparing and extrapolating between experimental and dynamic "real world" contributors to variance are severely compounded. Therefore, if the utility of ergonomics is gauged solely in terms of the extent to which it can supply "cookbook" answers to designers, then the ergonomics discipline itself will be judged a failure. Neither the time nor the resources are ever likely to exist, particularly in the midst of design problem solving, to evaluate parametrically all the conditions pertaining in an interactive real-world system problem. Ergonomics data are useful not because they are directly translatable to multifactor conditions (though some "cookbook" answers exist for some "cookbook" questions), but rather because they offer cues, clues, and confirmations to support the designer's reasoning processes (Refs. 3, 7).

The *Engineering Data Compendium: Human Perception and Performance* produced under the Integrated Perceptual Information for Designers (IPID) project is intended to provide ergonomics data as a technical resource for system design. To help ensure that the *Engineering Data Compendium* finds its way to the designer's workbench, rather than simply to the designer's bookshelf, the presentation of information has been tailored to the needs of the user. In particular, during development of the Compendium, systematic attention has been given to: (a) defining and validating approaches to effectively communicating ergonomics data to system designers in terms of presentation format, style, terminology, and level of technical content; and (b) enhancing the accessibility of specific technical information relevant to design problems by providing the user with reliable means of locating specific data.

In the development of the *Engineering Data Compendium*, we have learned from previous efforts in this area (Refs. 8-12) and have freely borrowed and integrated their successful elements into our approach. Nevertheless, the Compendium does have several unique features: one is the range and depth of the perception and performance data treated; another is the approach devised for communicating this information so that it is both comprehensible and accessible to the intended user.

What the Compendium Contains

The available body of psychological research contains a staggering volume of human perceptual and performance data and principles that are of potential value to system design. This includes data regarding basic sensory capacities and limitations (contrast sensitivity, spatial/temporal eye movement dynamics, aural and vestibular thresholds, etc.), as well as perception and human information processing (visual, aural, and proprioceptive pattern recognition, information portrayal, etc.). In the *Engineering Data Compendium*, basic data and principles from these areas are treated in depth and combined with applied human factors data into a single comprehensive reference source.

Eight classes of information are included in the *Engineering Data Compendium*:

1. Basic and parametric data (e.g., dynamic range of the visual system, spatial and temporal contrast sensitivity functions, physical response constants of the vestibular system, receiver operating characteristic curves).

2. Models and quantitative laws (e.g., CIE spaces, probability summation, operator control models). A model or law had to meet two criteria in order to be included: (a) it had to provide a way of interpolating or extrapolating existing data and relating them to a specific application, either to answer a design question directly or to specify the research needed to answer the question; and (b) it had to have a well defined and documented domain of reliable application.

3. Principles and nonquantitative or nonprecise formulations that express important characteristics of or trends in perception and performance (e.g., Gestalt grouping principles, interrelationship between size and distance judgments, depth and distance cues).

4. Phenomena that are inherently qualitative or that are general and pervasive, although quantitatively described in

specific instances (e.g., simultaneous brightness contrast, visual illusions, motion aftereffects).

5. Summary tables consolidating data derived from a body of studies related to a certain aspect of sensation, perception, or performance (e.g., table showing different acuity limits as measured with Landolt rings, grating patterns, etc.; table summarizing the effects of various factors known to affect stereoacuity).

6. Background information necessary for understanding and interpreting data entries and models (such as rudimentary anatomy and physiology of sensory systems, specialized units of measurement or measurement techniques; specific examples are anatomy of the ear, geometry of retinal image disparity, colorimetry techniques).

7. Section introductions to topical areas that describe the topic and set out its scope, explain general methods used in the given area of study, note general constraints regarding the application of data in the area, and provide references for further general information.

8. Tutorials containing expository material on general topics such as psychophysical methods, linear systems analysis, signal detection theory, etc., included both to help the user fully understand and evaluate the material in the Compendium, and to support research and evaluation studies in engineering development.

To make pertinent information more accessible to the user, graphic modes of presentation are used wherever possible. The Compendium contains over 2000 figures and tables, including data graphs, models, schematics, demonstrations of perceptual phenomena, and descriptions of methods and techniques. Other features of the Compendium include indicators of data reliability, caveats to data application, and the use of standardized units of measurement (Système International).

Data Presentation

To help the user locate and interpret pertinent information, a standardized presentation format has been developed for entries in the *Engineering Data Compendium* that is tailored to the needs of the design engineer. This format has evolved over several years through an iterative process of review and discussion with the user community, sponsors, and consultants. In its present form, it represents our best attempt at "human factoring" the presentation of relevant perceptual and performance data.

The basic unit of information in the Compendium is the individual *entry* addressing a narrow, well-defined topic. Each entry is centered around a graphic presentation such as a data function, model, schematic, etc. Supporting text is compartmentalized into a set of text modules or elements.

Data Access

The *Engineering Data Compendium* provides system designers with a wealth of relevant human performance and perceptual data heretofore unavailable to them in a useful form. However, access to the data in the Compendium is complicated by the fact that the perceptual concepts that underlie the data typically fall outside the scope of the training or experience of most practitioners. If these concepts are to be recognized as relevant to specific design problems,

Each of these elements provides a concise subunit of information designed in content and style to support understanding and application of the data. The entry format is described in detail in the *User's Guide* (Vol. IV).

The prescribed entry format has the advantages of both formal structure and adaptive modularity. The appearance of entries is generally uniform. In most cases, entries are presented on two facing pages. The type of information contained in each entry subsection is consistent across entries. Hence, the user can confidently access those elements needed to interpret or apply the data without being distracted by information irrelevant to the problem at hand. The format is also adaptable; only those elements appropriate to a given class or type of entry are presented.

they must be linked to information or issues familiar to the designer.

Several different means of accessing material are provided so that users with different interests and technical background can readily locate the information pertinent to their needs.

1. Tables of contents. Two levels of contents listings are provided: A brief, global table of contents enabling the

user to quickly determine the overall scope and organization of the Compendium may be found at the front of each volume. An expanded table of contents listing all subsections and entries by title is provided in the *User's Guide* (Vol. IV). An expanded contents for each major section of the Compendium is also located at the beginning of the corresponding section.

2. Sectional dividers. Each major section listed in the table of contents can be located rapidly by means of marginal tab dividers imprinted with the corresponding subject area title. Three of the topical sections (Sections 1.0, 5.0 and 7.0) are further subdivided by marginal tabs using size and color codings appropriate to the hierarchical scheme.

3. Glossary of technical terms. A brief glossary of definitions is provided at the beginning of each major topical section. A consolidated glossary is contained in the *User's Guide*.

4. Indices. A sectional keyword index is provided at the beginning of each major topical section. This index is designed to help both naive and experienced users formulate

their search questions in terms of relevant perceptual issues that may then be directly accessed within the Compendium.

5. Logic diagrams. At the beginning of each major topical section is a diagram showing the taxonomic hierarchy of subtopics and supporting entries for that section.

6. Cross references. Each Compendium entry includes extensive cross references to other Compendium entries and to sections of the *Handbook of Perception and Human Performance* (Refs. 11, 12) that provide more detailed treatment of a topic or subtopic, discussion of related topics, or explanatory material to aid in understanding or interpreting the data.

7. Design checklists. Found in the *User's Guide* are checklists of design-oriented questions suggesting human performance variables that should be considered in the specification of equipment.

In addition, the *User's Guide* comprising Volume IV of the Compendium provides instructions for accessing data and a description of the format and organization of information in the Compendium.

References

- Boff, K.R. (1987). Designing for Design Effectiveness of Complex Avionics Systems. *The Design, Development and Testing of Complex Avionics Systems*. Las Vegas, NV: NATO Advisory Group for Aerospace Research and Development.
- Boff, K.R. (1987). The Tower of Babel Revisited: On Cross-disciplinary Chokepoints in System Design. In W.B. Rouse & K.R. Boff (Eds.), *System Design: Behavioral Perspectives on Designers, Tools and Organizations*. New York: Elsevier.
- Meister, D., & Farr, D. (1966). *The Utilization of Human Factors Information by Designers*. Arlington, VA: Office of Naval Research, NONR Contract #4974-00.
- Boff, K.R., Calhoun, G. L., & Lincoln, J. (1984). *Making Perceptual and Human Performance Data an Effective Resource for Designers*. Proceedings of the NATO DRG Workshop (Panel 4). Shri-venham, England: Royal College of Science.
- Mackie, R. R. (1984). Research Relevance and the Information Glut. In F.A. Muckler (Ed.), *Human Factors Review*. Santa Monica, CA: Human Factors Society.
- Meister, D. (1987). A Cognitive Theory of Design and Requirements for a Behavioral Design Aid. In W.B. Rouse and K.R. Boff, (Eds.), *System Design: Behavioral Perspectives on Designers, Tools and Organizations*. New York: Elsevier.
- Boff, K.R. (1987). Matching Crew System Specifications to Human Performance Capabilities. Stuttgart, Germany: NATO Advisory Group for Aerospace Research and Development.
- Tufts College. (1952). *Handbook of Human Engineering Data*. Medford, MA: Tufts College.
- Farrell, R.J., & Booth, J.M. (1984). Design Handbook for Imagery Interpretation Equipment (2nd. ed.). Seattle WA: Boeing Aerospace Company. (Report D180-19063-1).
- Van Cott, H.P., & Kinkade, R.G. (Eds.). (1972). *Human Engineering Guide to Equipment Design* (2nd. Ed.). Washington D.C.: American Institutes for Research.
- Boff, K.R., Kaufman, L., & Thomas J. (Eds.). (1986). *Handbook of Perception and Human Performance. Vol. I: Sensory Processes and Perception*. New York: John Wiley and Sons.
- Boff, K.R., Kaufman, L., & Thomas, J. (Eds.). (1986). *Handbook of Perception and Human Performance. Vol. II: Cognitive Processes and Performance*. New York: John Wiley and Sons.
- Rouse, W.B., & Boff, K.R. (1987). *System Design: Behavioral Perspectives on Designers, Tools and Organizations*. New York: Elsevier.

Contents for Volume I

Foreword	<i>xi</i>
Preface and Acknowledgments	<i>xiii</i>
Credits for Volume I	<i>xix</i>
Introduction	<i>xxxi</i>

Section 1.0 Visual Acquisition of Information

1.1 Measurement of Light	<i>1</i>
1.2 Optics of the Eye	<i>33</i>
1.3 Sensitivity to Light	<i>117</i>
1.4 Adaptation: Changes in Sensitivity	<i>137</i>
1.5 Sensitivity to Temporal Variations	<i>165</i>
1.6 Spatial Sensitivity	<i>193</i>
1.7 Color Vision	<i>323</i>
1.8 Binocular Vision	<i>391</i>
1.9 Eye Movements	<i>421</i>

Section 2.0 Auditory Acquisition of Information

2.1 Measurement of Sound	<i>554</i>
2.2 Physiology of the Ear	<i>568</i>
2.3 Detection	<i>572</i>
2.4 Discrimination	<i>612</i>
2.5 Temporal Resolution	<i>614</i>
2.6 Loudness	<i>622</i>
2.7 Pitch	<i>650</i>
2.8 Localization	<i>672</i>

Section 3.0 Acquisition of Information by Other Senses

3.1 Cutaneous Sensitivity	<i>712</i>
3.2 Vestibular Sensitivity	<i>766</i>
3.3 Kinesthesia	<i>788</i>

Organization of Entries

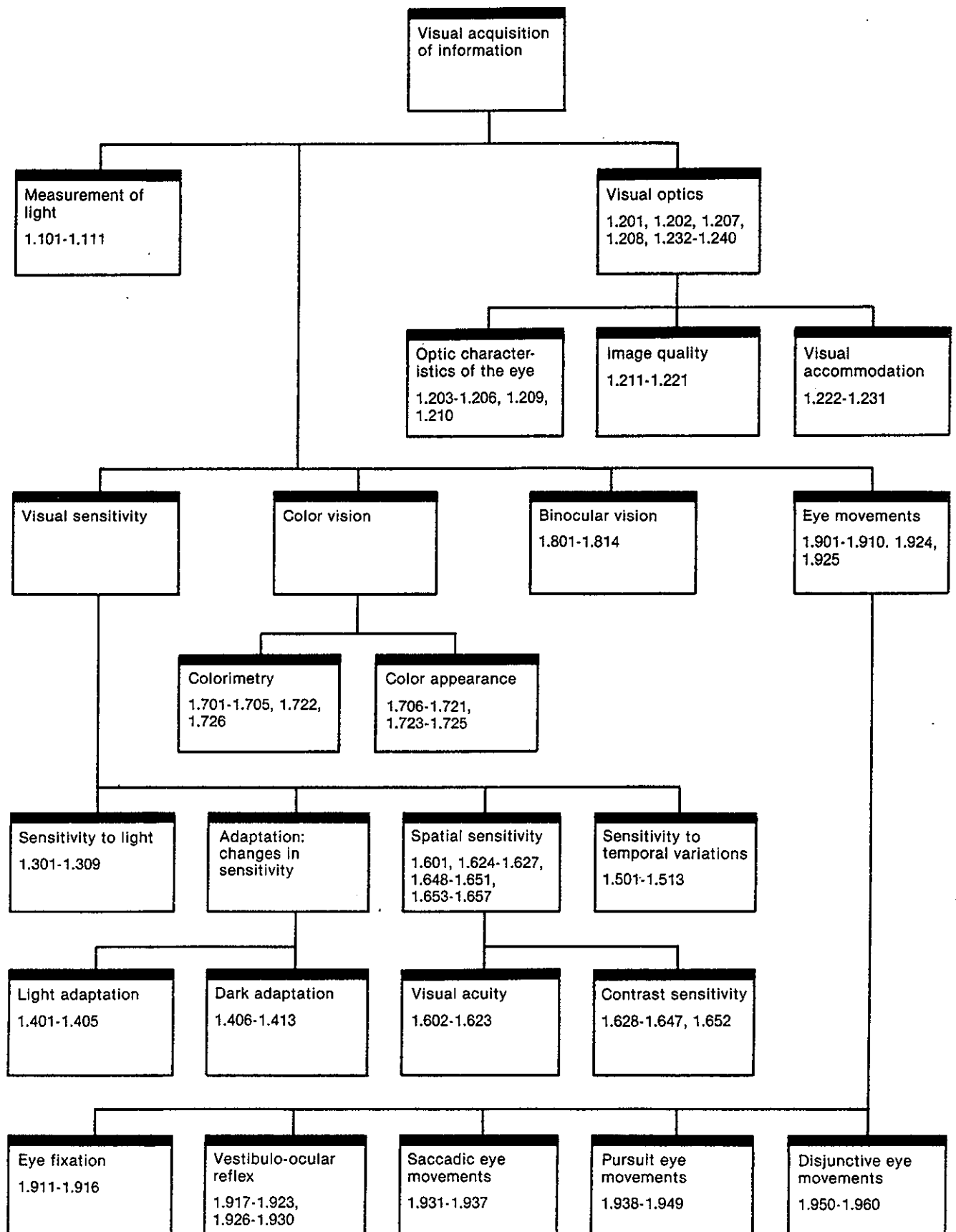

Contents

Section 1.1 Measurement of Light

- | | |
|--|--|
| 1.101 Range of Visible Energy in the Electromagnetic Radiation Spectrum | 1.107 Color Temperature |
| 1.102 Spectral Distribution of Radiant Energy | 1.108 Spectral Transmittance and Reflectance |
| 1.103 Range of Light Intensities Confronting the Eye | 1.109 Photometric Techniques for Measuring Spectral Sensitivity |
| 1.104 Measurement of Radiant and Luminous Energy | 1.110 Luminous Efficiency (Spectral Sensitivity) |
| 1.105 Image Luminance with Optical Viewers | 1.111 Luminous Efficiency: Effect of Pupil Entry Angle |
| 1.106 Conversion of Scene Luminance to Retinal Illuminance | |

Section 1.2 Optics of the Eye

- | | |
|---|--|
| 1.201 Anatomy of the Human Eye | 1.223 Resting Position of Accommodation |
| 1.202 Transmissivity of the Ocular Media | 1.224 Normal Variation in Accommodation |
| 1.203 The Eye as an Optical Instrument | 1.225 Normal Variation in Accommodation: Similarity in the Two Eyes |
| 1.204 Spherical Refractive Errors | 1.226 Visual Accommodation: Effect of Luminance Level and Target Structure |
| 1.205 Astigmatism | 1.227 Eye Focus in Dim Illumination (Night Myopia) |
| 1.206 Effect of Lenses on the Visual Image | 1.228 Accommodation: Effect of Dark Focus, Luminance Level, and Target Distance |
| 1.207 Eye Center of Rotation and Rotation Limits | 1.229 Accommodation: Effect of Oscillatory Changes in Target Distance |
| 1.208 Interpupillary Distance | 1.230 Accommodation: Effect of Abrupt Changes in Target Distance |
| 1.209 Visual Optics | 1.231 Relation Between Accommodation and Convergence |
| 1.210 Optical Constants of the Eye | 1.232 Monocular Versus Binocular Pupil Size |
| 1.211 Spherical Aberration | 1.233 Pupil Size: Effect of Luminance Level |
| 1.212 Axial Chromatic Aberration | 1.234 Pupil Size: Effect of Target Distance |
| 1.213 Diffraction of Light in Optical Systems | 1.235 The Normal Achromatic Visual Field |
| 1.214 The Point-Spread Function of the Eye | 1.236 The Lateral Achromatic Visual Field: Age and Sex Differences |
| 1.215 The Line-Spread Function of the Eye | 1.237 Normal Visual Fields for Color |
| 1.216 Width of the Line-Spread Function: Effect of Visual Field Location and Eye Focus | 1.238 Visual Field Coordinate Systems |
| 1.217 Retinal Light Distribution for an Extended Source | 1.239 Visual Effects of Empty-Field (Ganzfeld) Viewing |
| 1.218 Fourier Description of the Eye's Imaging Property | 1.240 Visual Angle and Retinal Size |
| 1.219 Modulation Transfer Function of Optical Systems | |
| 1.220 Modulation Transfer Function of the Eye for Defocused Imagery | |
| 1.221 Image Quality and Depth of Focus | |
| 1.222 Visual Accommodation | |

Section 1.3 Sensitivity to Light

- | | |
|---|---|
| 1.301 Scotopic and Photopic (Rod and Cone) Vision | 1.305 Factors Affecting Sensitivity to Light |
| 1.302 Spectral Sensitivity | 1.306 Absolute Sensitivity to Light: Effect of Visual Field Location |
| 1.303 Equal-Brightness and Equal-Lightness Contours for Targets of Different Colors (Spectral Content) | 1.307 Absolute Sensitivity to Light: Effect of Target Area and Visual Field Location |
| 1.304 Equal-Brightness Contours for Lights of Different Colors (Wavelengths) at Different Levels of Adapting Luminance | 1.308 Spatial Summation of Light Energy |
| | 1.309 Afterimages |

Section 1.4 Adaptation: Changes in Sensitivity

- 1.401** Brightness Difference Threshold: Effect of Background Luminance
- 1.402** Brightness Difference Threshold: Effect of Background Luminance and Duration of Luminance Increment
- 1.403** Brightness Difference Threshold: Effect of Background Luminance and Target Size
- 1.404** Intensity Difference Threshold: Effect of Luminance Increment Versus Decrement
- 1.405** Time Course of Light Adaptation
- 1.406** Factors Affecting Dark Adaptation
- 1.407** Dark Adaptation: Effect of Wavelength
- 1.408** Dark Adaptation: Effect of Target Size
- 1.409** Dark Adaptation: Effect of Spatial and Temporal Summation
- 1.410** Visual Resolution During Dark Adaptation
- 1.411** Dark Adaptation Following Exposure to Light of Varying Intensity
- 1.412** Dark Adaptation Following Exposure to Light Fields of Varying Size
- 1.413** Dark Adaptation Following Exposure to Light of Varying Duration

Section 1.5 Sensitivity to Temporal Variations

- 1.501** Factors Affecting Sensitivity to Flicker
- 1.502** Flicker Sensitivity: Effect of Background Luminance
- 1.503** Flicker Sensitivity: Effect of Flicker Frequency and Luminance Level
- 1.504** Flicker Sensitivity: Effect of Dark Adaptation for Targets at Different Visual Field Locations
- 1.505** Flicker Sensitivity: Effect of Type of Target and Luminance Level
- 1.506** Flicker Sensitivity: Effect of Target Size and Surround
- 1.507** Flicker Sensitivity: Effect of Target Size
- 1.508** Flicker Sensitivity: Effect of Target Spatial Frequency
- 1.509** Flicker Perception Versus Pattern Perception in Temporally Modulated Targets
- 1.510** Detection and Discrimination of Flicker Rate
- 1.511** Factors Affecting Sensitivity to Brief (Pulsed) Targets
- 1.512** Time-Intensity Trade-Offs in Detection of Brief Targets: Effect of Duration, Target Intensity, and Background Luminance
- 1.513** Model of Temporal Sensitivity

Section 1.6 Spatial Sensitivity

- 1.601** Luminance Description of Visual Patterns
- 1.602** Measurement of Visual Acuity
- 1.603** Factors Affecting Visual Acuity
- 1.604** Visual Acuity: Effect of Luminance Level
- 1.605** Visual Acuity: Effect of Target and Background Luminance and Contrast
- 1.606** Visual Acuity: Effect of Illuminant Wavelength
- 1.607** Vernier Acuity and Orientation Sensitivity: Effect of Adjacent Contours
- 1.608** Two-Dot Vernier Acuity: Effect of Dot Separation
- 1.609** Visual Acuity: Difference Thresholds for Spatial Separation
- 1.610** Vernier Acuity: Offset Discrimination Between Sequentially Presented Target Segments
- 1.611** Visual Acuity: Effect of Target Location in the Visual Field at Photopic Illumination Levels
- 1.612** Visual Acuity: Effect of Target Location in the Visual Field at Scotopic Illumination Levels
- 1.613** Visual Acuity: Effect of Exposure Time
- 1.614** Visual Acuity: Effect of Pupil Size
- 1.615** Visual Acuity: Effect of Viewing Distance
- 1.616** Visual Acuity: Effect of Viewing Distance and Luminance Level
- 1.617** Visual Acuity with Target Motion: Effect of Target Velocity and Target Versus Observer Movement
- 1.618** Visual Acuity with Target Motion: Effect of Target Velocity and Orientation
- 1.619** Visual Acuity with Target Motion: Effect of Direction of Movement and Luminance Level
- 1.620** Visual Acuity with Target Motion: Effect of Direction of Movement and Target Orientation
- 1.621** Visual Acuity with Target Motion: Effect of Anticipation Time and Exposure Time
- 1.622** Visual Acuity with Target Motion: Effect of Practice
- 1.623** Visual Acuity and Contrast Sensitivity: Effect of Age
- 1.624** Factors Affecting Detection of Spatial Targets
- 1.625** Target Detection: Effect of Target Spatial Dimensions
- 1.626** Target Detection: Effect of Prior Exposure (Adaptation) to a Target of the Same or Different Size
- 1.627** Target Detection: Effect of Spatial Uncertainty
- 1.628** Factors Affecting Contrast Sensitivity for Spatial Patterns
- 1.629** Contrast Sensitivity: Effect of Field Size
- 1.630** Contrast Sensitivity: Effect of Spatial Frequency Composition
- 1.631** Contrast Sensitivity: Effect of Number of Luminance Modulation Cycles and Luminance Level

- | | |
|--|--|
| 1.632 Contrast Sensitivity: Effect of Luminance Level (Foveal Vision) | 1.644 Contrast Sensitivity for Snellen Letters |
| 1.633 Contrast Sensitivity: Effect of Luminance Level (Peripheral Vision) | 1.645 Contrast Sensitivity for a Large Population Sample |
| 1.634 Contrast Sensitivity: Effect of Target Orientation | 1.646 Contrast Discrimination |
| 1.635 Contrast Sensitivity: Effect of Target Visual Field Location for Bar Patterns of Varying Size | 1.647 Contrast Matching |
| 1.636 Contrast Sensitivity: Effect of Visual Field Location for Circular Targets of Varying Size | 1.648 Spatial Frequency (Size) Discrimination |
| 1.637 Contrast Sensitivity: Effect of Target Motion | 1.649 Spatial Frequency (Size) Discrimination: Effect of Contrast |
| 1.638 Contrast Sensitivity: Effect of Pupil Size | 1.650 Spatial Frequency (Size) Masking |
| 1.639 Contrast Sensitivity: Effect of Focus Errors | 1.651 Spatial Frequency (Size) Adaptation |
| 1.640 Contrast Sensitivity: Effect of Viewing Distance and Noise Masking | 1.652 Orientation-Selective Effects on Contrast Sensitivity |
| 1.641 Contrast Sensitivity: Effect of Edge Sharpness | 1.653 Threshold Models of Visual Target Detection |
| 1.642 Contrast Sensitivity: Effect of Border Gradient | 1.654 Continuous-Function Models of Visual Target Detection |
| 1.643 Contrast Sensitivity: Effect of Target Shape and Illumination Level | 1.655 Vector Models of Visual Identification |
| | 1.656 Psychophysical Methods |
| | 1.657 Psychometric Functions |

Section 1.7 Color Vision

- | | |
|---|---|
| 1.701 Targets and Procedures Used to Study Color Perception | 1.714 Simultaneous Lightness Contrast: Effect of Perceptual Organization |
| 1.702 Color Mixture and Color Matching | 1.715 Model of Brightness Contrast |
| 1.703 Colorimetric Purity and Excitation Purity | 1.716 Mach Bands |
| 1.704 Chromaticity Discrimination | 1.717 Simultaneous Color Contrast |
| 1.705 Factors Affecting Color Discrimination and Color Matching | 1.718 Color Assimilation |
| 1.706 Descriptive Attributes of Color Appearance | 1.719 Phantom Colors |
| 1.707 Factors Influencing Color Appearance | 1.720 Brightness Scales |
| 1.708 Hue: Effect of Saturation Changes (Abney Effect) | 1.721 Lightness Scales |
| 1.709 Hue: Effect of Luminance Level (Bezold-Brücke Effect) | 1.722 Color Specification and the CIE System of Colorimetry |
| 1.710 Hue and Chroma: Shifts Under Daylight and Incandescent Light | 1.723 Color-Order Systems |
| 1.711 Fluorescence or Color Glow | 1.724 Color-Order Systems: Munsell System |
| 1.712 Brightness Constancy | 1.725 Color-Order Systems: Optical Society of America System |
| 1.713 Brightness Induction | 1.726 Congenital Color Defects |

Section 1.8 Binocular Vision

- | | |
|--|--|
| 1.801 Advantage of Binocular over Monocular Vision | 1.808 Convergence Angle |
| 1.802 Monocular Versus Binocular Contrast Sensitivity | 1.809 Phoria |
| 1.803 Binocular Combination of Brightness and Contrast | 1.810 Incidence of Lateral and Vertical Phorias |
| 1.804 Binocular Suppression and Rivalry | 1.811 Eye Signature: Discrimination of Which Eye Is Stimulated |
| 1.805 Spatial Extent of Binocular Suppression | 1.812 Binocular Displays |
| 1.806 Time Course of Binocular Suppression and Rivalry | 1.813 Alignment and Adjustment Tolerances for Binocular Instruments |
| 1.807 Visual Sensitivity and Performance During Binocular Suppression | 1.814 Probability Summation |

Section 1.9 Eye Movements

- 1.901** Anatomy and Mechanics of Eye Movements
- 1.902** Muscular Control of the Eyes
- 1.903** Coordinate Systems for Describing Eye Movements
- 1.904** Methods of Measuring Eye Movements
- 1.905** Summary of Eye Movements According to Direction and Axis of Rotation
- 1.906** Classification of Eye Movements
- 1.907** Adaptability of Eye Movements
- 1.908** Effect of Fatigue on Eye Movements
- 1.909** Maladaptive Eye Movements: Eliciting Conditions
- 1.910** Control-Systems-Analysis Model of Visual and Oculomotor Functions in Retinal Image Stabilization
- 1.911** Visual Fixation Stability in the Dark
- 1.912** Fixation Stability: Magnitude of Horizontal Drift
- 1.913** Visual Fixation: Relationship Between Head and Eye Movements
- 1.914** Monocular Fixation on Stationary Targets
- 1.915** Effects of Target Characteristics on Eye Movements and Fixation
- 1.916** Visual Fixation on Dimly Illuminated Targets
- 1.917** Factors Affecting the Vestibulo-Ocular Reflex
- 1.918** Factors Influencing Visual Suppression of Vestibular Nystagmus
- 1.919** Visual Suppression of Vestibular Nystagmus: Effect of Direction of Head Inclination
- 1.920** Visual Suppression of Vestibular Nystagmus: Effect of Fixation
- 1.921** Vestibulo-Ocular Nystagmus During and After Aircraft Spin
- 1.922** Vestibular-Ocular Nystagmus: Interaction of Quick Phase Nystagmus and Saccades with Eye/Head Tracking
- 1.923** Factors Influencing Duration of Postrotary Nystagmus
- 1.924** Optokinetic Nystagmus and Circularvection (Illusory Self-Motion)
- 1.925** Optokinetic Nystagmus: Effect of Instructions
- 1.926** Factors Affecting Gain of Vestibulo-Ocular Reflex
- 1.927** Vestibulo-Ocular Reflex in the Presence of Visual Distortion
- 1.928** Gain of Vestibular Nystagmus: Effect of Object Distance
- 1.929** Vestibular Nystagmus: Effect of Attention
- 1.930** Vestibular Nystagmus: Effect of Angular Acceleration and Deceleration
- 1.931** Duration and Amplitude of Saccades in the Absence of Targets
- 1.932** Factors Influencing the Latency of Saccades
- 1.933** Saccadic Velocity: Effect of Saccade Distance
- 1.934** Elicitation of Saccades: Effects of Target Size and Proximity to Fovea
- 1.935** Patterns and Errors in Saccadic Eye Movements: Effect of Visual Task
- 1.936** Timing and Accuracy of Saccades to Briefly Lit Targets
- 1.937** Voluntary Control of Saccadic Eye Movements
- 1.938** Model of Pursuit Eye Movements
- 1.939** Factors Affecting Smooth Pursuit Eye Movements
- 1.940** Gain and Phase of Smooth Pursuit Eye Movements: Effect of Target Motion
- 1.941** Gain of Tracking Eye Movements: Effects of Target Luminance and Visual Field Location
- 1.942** Latency and Velocity of Smooth Pursuit Eye Movements: Effect of Target Velocity
- 1.943** Visual Tracking of Random One-Dimensional Motion
- 1.944** Visual Tracking of Complex Sinusoidal Motion
- 1.945** Accuracy of Tracking Eye Movements: Effect of Target Velocity
- 1.946** Accuracy of Tracking Eye Movements: Effects of Target Motion
- 1.947** Visual Tracking: Effects of Perceived Versus Real Target Motion
- 1.948** Involuntary Anticipatory Eye Movements
- 1.949** Tracking of Targets Oscillating in Depth
- 1.950** Factors Affecting Vergence Eye Movements
- 1.951** Prolonged Convergence of the Eyes
- 1.952** Vergence Eye Movements: Eliciting Target Characteristics
- 1.953** Disjunctive Eye Movements in Response to Accommodative Stimuli
- 1.954** Disjunctive Eye Movements in Response to Peripheral Image Disparity
- 1.955** Fusional Eye Movements in Response to Vertical Disparity
- 1.956** Eye Torsion: Effects of Angular Disparity in Binocular Display Patterns
- 1.957** Factors Affecting Countertorsion of the Eyes
- 1.958** Eye Movements Induced by Head and Body Movements
- 1.959** Eye Torsion in Response to Lateral Head Tilt
- 1.960** Factors Affecting Coordination of Head Rotation and Eye Movements

Key Terms

- Aberration (optical), 1.211, 1.212
 Abney effect, 1.708
 Absolute threshold, 1.656
 Absorption defect, 1.726
 AC/A ratio, 1.231
 Acceleration, angular, 1.930
 Acceleration, rotary, 1.958
 Accommodation, 1.222-1.231, 1.603, 1.639, 1.640, 1.953
 Accommodation, resting, 1.223, 1.228
 Achromatic contrast, 1.601
 Achromatic induction, 1.707, 1.713, 1.715, 1.716
 Achromatic lightness scale, 1.721
 Acuity. *See* Vernier acuity; visual acuity
 Adaptability, 1.907
 Adaptation, 1.401-1.413, 1.652.
See also Chromatic adaptation, dark adaptation, light adaptation, perceptual adaptation, selective adaptation
 Adduction, 1.902
 Aftereffects, contingent, 1.309
 Afterimages, 1.309
 Age, 1.603, 1.623, 1.707
 Aircraft spin, 1.921
 Airy's disk, 1.213
 Alteration defect, 1.726
 Amblyopia, 1.932
 Ametropia, 1.204
 Anisometropia, 1.205
 Aqueous humor, 1.210
 Astigmatism, 1.205
 Attention, 1.929, 1.934, 1.939
 Autostereoscope, 1.812
 Axial chromatic aberration, 1.212
- Beamsplitter, 1.108
 Benham's disk, 1.719
 Bezold-Brücke effect, 1.709
 Bezold spreading effect, 1.718
 Binocular averaging, 1.803
 Binocular display, 1.812, 1.813
 Binocular enhancement, 1.801
 Binocular eye movements, 1.903
 Binocular fixation, 1.808
 Binocular interaction, 1.801
 Binocular misalignment, 1.813
 Binocular rivalry, 1.804-1.807
 Binoculars, 1.105
 Binocular summation, 1.801-1.803, 1.814
 Binocular suppression, 1.804-1.807
 Binocular viewing, 1.208, 1.801, 1.802, 1.913, 1.949-1.956
 Binocular vision, 1.801-1.814
 Blackbody radiator, 1.107
 Bloch's law, 1.402, 1.512
 Blur patch, 1.211, 1.221
 Border effects, 1.707, 1.716
 Brightness, 1.109-1.111, 1.303, 1.304, 1.706, 1.707, 1.710-1.713, 1.715, 1.720, 1.803
 Brightness constancy, 1.712, 1.715
 Brightness contrast, 1.713-1.715
 Brightness discrimination, 1.401-1.403, 1.413
 Brightness induction, 1.713, 1.715
- Brightness matching, 1.109, 1.303, 1.701, 1.715
 Brightness scale, 1.720
 Brunswik ratio, 1.712
- Cancellation theory, 1.938
 Cervico-ocular nystagmus, 1.958
 Chroma, 1.706-1.708, 1.710
 Chroma, Munsell, 1.724
 Chromatic aberration, 1.212
 Chromatic adaptation, 1.705, 1.710
 Chromatic induction, 1.701, 1.707, 1.717, 1.718
 Chromaticity, 1.107, 1.303, 1.702, 1.704, 1.710, 1.722
 Chromaticity coordinates, 1.722
 Chromaticity diagram, 1.722
 Chromatism, 1.212
 CIE standard colorimetric observer, 1.722
 Circularvection, 1.924
 Color, 1.606, 1.701-1.726
 Color, illusory, 1.719
 Color, phantom, 1.719
 Color, subjective, 1.719
 Color appearance, 1.301, 1.303, 1.701, 1.706-1.710, 1.712, 1.713, 1.715-1.721, 1.723-1.725
 Color assimilation, 1.718
 Color blindness, 1.726
 Color contrast, 1.716, 1.717
 Color defect, 1.726
 Color description, 1.706
 Color discrimination, 1.704, 1.705
 Color glow, 1.711
 Color matching, 1.702, 1.705
 Color matching function, 1.722
 Color mixture, 1.702, 1.708, 1.723
 Color mixture, additive, 1.723
 Color mixture, subtractive, 1.723
 Color-order system, 1.723-1.725
 Color-order system, Munsell, 1.724
 Color specification, 1.722
 Color spreading, 1.718
 Color temperature, 1.102, 1.107
 Colorant mixture, 1.723
 Colorimetric observer, standard, 1.722
 Colorimetric purity, 1.703, 1.704, 1.706, 1.707, 1.710, 1.722
 Colorimetry, 1.102, 1.107, 1.701-1.704, 1.722
 Compensatory eye movements, 1.905, 1.917, 1.921, 1.926-1.928, 1.959
 Complementary wavelength, 1.722
 Complexity, target, 1.643
 Cones, 1.301, 1.302
 Cone vision. *See* Photopic vision
 Contingent aftereffects, 1.309
 Contour effects, 1.707
 Contrast, 1.404, 1.601, 1.603-1.605, 1.633, 1.649, 1.707, 1.712, 1.715, 1.803. *See also* Brightness contrast, color contrast, lightness contrast, spatial contrast
 Contrast discrimination, 1.646
 Contrast matching, 1.647
 Contrast modulation, 1.219, 1.220
 Contrast ratio, 1.601
- Contrast sensitivity, 1.602, 1.603, 1.623, 1.628-1.647, 1.650-1.652, 1.802
 Contrast sensitivity, temporal, 1.503, 1.505, 1.506, 1.509
 Contrast summation, 1.802
 Control, active, 1.946
 Control, passive, 1.946
 Convergence, 1.208, 1.231, 1.808-1.810, 1.902, 1.905, 1.928, 1.951, 1.952
 Coordinate systems, 1.238, 1.903
 Cornea, 1.201, 1.203, 1.210
 Corneal reflection, 1.904, 1.906
 Corollary discharge, 1.910
 Countertorsion, 1.957-1.959
 Critical duration, 1.402, 1.512
 Critical flicker frequency, 1.504, 1.507
 Critical size, 1.307, 1.308
 Cumulative normal function, 1.657
 Cupulometry, 1.923
 Cycloduction, 1.901
 Cyclorotation, 1.956, 1.959
- Dark adaptation, 1.232, 1.233, 1.305, 1.306, 1.406-1.413, 1.504
 Dark focus, 1.223, 1.228
 Daytime vision. *See* Photopic vision
 Deceleration, angular, 1.930
 Declination error, 1.205
 Depth of field, 1.221
 Depth of focus, 1.221
 Depth perception, 1.239, 1.615, 1.951-1.953
- Detection. *See* Gap detection; light sensitivity; pattern detection; target detection; visual detection
 Detection models, continuous, 1.654
 Detection models, threshold, 1.653
 Deutan, 1.726
 Deuteranomaly, 1.726
 Deuteranopia, 1.726
 De Vries-Rose law, 1.502
 Dichromacy, 1.726
 Difference threshold, 1.656.
See also Intensity difference threshold, light increment threshold, spatial frequency difference threshold
 Diffraction, 1.213-1.217, 1.219, 1.220, 1.614
 Digital displays, 1.920
 Dim targets, 1.936
 Diplopia. *See* Double vision
 Discrimination, 1.655. *See also* Brightness discrimination, color discrimination, contrast discrimination, purity discrimination, size discrimination, spatial frequency discrimination, spatial orientation discrimination, utrocular discrimination
 Disjunctive eye movements, 1.906, 1.949, 1.953-1.955
 Disorientation, 1.921, 1.927
 Disparity. *See* Retinal image disparity
 Display brightness, 1.105
 Distortion, visual, 1.927
 Divergence, 1.808
- Dominant wavelength, 1.722
 Double vision, 1.813, 1.955
 Duplicity model, 1.302
 Duration. *See* Exposure duration
 Dynamic visual acuity, 1.617-1.622
- Eccentricity. *See* Retinal location, visual field location
 Edge sharpness, 1.641, 1.642
 Effectivity ratio, 1.106
 Electro-oculography, 1.904, 1.917, 1.920, 1.922, 1.927, 1.930
 Emmetropia, 1.204
 End-primary error, 1.946
 Entrance pupil, 1.209
 Esophoria, 1.902
 Excitation purity, 1.703, 1.708, 1.722
 Exit pupil, 1.105, 1.209
 Exophoria, 1.902
 Expectation, 1.621, 1.939
 Exposure duration, 1.402, 1.501, 1.511, 1.512, 1.603, 1.613, 1.624, 1.705, 1.707
 Eye, model or schematic, 1.209, 1.210
 Eye, optics, 1.201-1.240
 Eyeball, 1.201
 Eye drifts, 1.911, 1.914, 1.916
 Eye focus, 1.201, 1.203-1.205, 1.209, 1.211-1.231, 1.639
 Eye-head coordination, 1.910, 1.917, 1.919-1.922, 1.926, 1.927, 1.958, 1.960
 Eye movements, 1.610, 1.808, 1.901-1.947. *See also* subentries below and Compensatory eye movements; disjunctive eye movements; involuntary eye movements; nystagmus; pursuit eye movements; saccadic eye movements; torsional eye movements; tracking eye movements; vergence eye movements
 Eye movements, abrupt, 1.906
 Eye movements, anticipatory, 1.948
 Eye movements, conjugate, 1.906
 Eye movements, control of, 1.910, 1.911
 Eye movements, cyclofusional, 1.956
 Eye movements, degraded, 1.929
 Eye movements, horizontal, 1.903, 1.931
 Eye movements, maladaptive, 1.909, 1.915
 Eye movements, measurement of, 1.904
 Eye movements, vertical, 1.903
 Eyepiece, 1.105
 Eye rotation, 1.207
 Eye signature, 1.811
 Eye tremor, 1.912
- Facilitation, visual, 1.650
 Farbenglut, 1.711
 Farsightedness, 1.204
 Fatigue, 1.908
 Fechner's colors, 1.719
 Fechner's paradox, 1.803
 Fick coordinate system, 1.903

1.0 Visual Acquisition of Information

- Field of view, 1.235-1.237, 1.406, 1.412, 1.925
Filtering defect, 1.726
Filters, 1.108
Fixation, visual, 1.905, 1.907-1.909, 1.911, 1.912, 1.914-1.918, 1.920-1.924, 1.926-1.930, 1.934-1.938, 1.941, 1.945-1.947, 1.956, 1.958, 1.960
Fixation disparity, 1.951
Fixation stability, 1.911
Flash bleaching, 1.412
Flicker, 1.501-1.513, 1.628
Flicker detection, 1.501-1.509, 1.510, 1.513
Flicker discrimination, 1.510
Flicker frequency, 1.501-1.503, 1.505, 1.508
Fluorence, 1.711
Fluorescence, 1.711
Focus, 1.201. *See* Eye focus
Focus defect, 1.204, 1.221
Forced-choice procedure, 1.657
Fourier analysis, 1.630
Fovea, 1.201
Foveal vision, 1.301, 1.307, 1.405, 1.408
Fraunhofer diffraction pattern, 1.213
Frequency. *See* Spatial frequency; temporal frequency
Frequency-of-seeing curve, 1.657
Fusional vergence, 1.950, 1.955, 1.956
Gain, 1.939
Ganzfeld, 1.239
Gap detection, 1.613-1.615, 1.617-1.619, 1.621, 1.622
Gap discrimination, 1.609
Glissades, 1.908
Gravitational effects, 1.957
Gray scale, 1.721
Head roll, 1.921
Head rotation, 1.917, 1.919, 1.920, 1.922, 1.923, 1.927, 1.928, 1.960
Head tilt, 1.957-1.959
Helmet-mounted displays, 1.918, 1.920, 1.928
Helmholtz coordinate system, 1.903
Hering's law of equal innervation, 1.956
Heterochromatic brightness matching, 1.109, 1.303, 1.701
Heterochromatic flicker photometry, 1.109, 1.701
Heterochromatic lightness matching, 1.303
Heterophoria, 1.809, 1.810
Hue, 1.706-1.710, 1.722
Hue, Munsell, 1.724
Hyperacuity, 1.607-1.609
Hyperopia, 1.204
Ideal radiator, 1.107
Identification, 1.655. *See also* Discrimination
Illumination level, 1.103, 1.104, 1.710
Illusions, turning, 1.923
Illusions, vestibular, 1.923, 1.930
Illusions, visual, 1.239
Image alignment, 1.607, 1.608, 1.610, 1.813
Image intensity distribution, 1.214, 1.215, 1.217-1.219, 1.220
Image motion, 1.618. *See also* Target motion
Image prevalence, 1.804-1.806
Independence, statistical, 1.814
Induction, brightness, 1.713, 1.715
Induction, chromatic, 1.701, 1.707, 1.717, 1.718
Induction, lightness, 1.713-1.715
Inferior oblique muscle, 1.902
Instructions, 1.917, 1.925
Intensity difference threshold, 1.305, 1.404
Intermittent illumination, 1.918
Interpupillary distance, 1.208
Interstimulus interval, 1.511
Inverse square law, 1.104
Involuntary eye movements, 1.905, 1.912, 1.922, 1.926, 1.958
Irradiance, 1.104
Labeled channel, 1.655
Latency, 1.909
Lens, 1.206, 1.212
Lens, of the eye, 1.201, 1.203, 1.209, 1.210, 1.222-1.226, 1.228-1.231
Letter recognition, 1.807
Light adaptation, 1.232, 1.233, 1.305, 1.401-1.403, 1.405, 1.501, 1.503, 1.505, 1.511-1.513, 1.624
Light increment threshold, 1.401-1.403, 1.405, 1.406, 1.413
Lightness, 1.303, 1.706, 1.707, 1.710, 1.712-1.715, 1.721
Lightness constancy, 1.712, 1.715
Lightness contrast, 1.715
Lightness induction, 1.713-1.715. *See also* Achromatic induction
Lightness matching, 1.303, 1.701, 1.715
Lightness scale, 1.721
Light measurement, 1.101-1.111
Light scatter, 1.213-1.215, 1.217
Light sensitivity, 1.102, 1.301-1.309, 1.401-1.413
Line of sight, primary, 1.939
Line-spread function, 1.214-1.216
Localization, visual, 1.912, 1.938
Listing coordinate system, 1.903
Logistic function, 1.657
Log-normal function, 1.657
Luminance, 1.103, 1.104, 1.228, 1.305, 1.502, 1.503, 1.505, 1.511, 1.512, 1.601, 1.603-1.605, 1.616, 1.619, 1.624, 1.628, 1.631-1.633, 1.641, 1.705-1.707, 1.709, 1.712, 1.713, 1.715, 1.720, 1.721, 1.932
Luminosity, 1.104, 1.109, 1.110, 1.111
Luminosity function, 1.109, 1.110
Luminous efficiency, 1.104, 1.109-1.111, 1.302, 1.304, 1.701
Luminous flux, 1.104
Mach bands, 1.716
Macula lutea, 1.201, 1.202
Magnitude estimation, 1.656
Masking, visual, 1.603, 1.607, 1.650, 1.652
McCullough effect, 1.309
Mesopic vision, 1.103, 1.110
Metamerism, 1.702
Method of adjustment, 1.656
Method of constant stimuli, 1.656
Method of limits, 1.656
Method of paired comparisons, 1.656
Michelson contrast, 1.601
Microsaccades, 1.914, 1.933
Microscope, 1.105
Microtremors, 1.914
Minimally distinct border technique, 1.109
Minimum angle of resolution, 1.611-1.613
Misalignment, image, 1.607, 1.608, 1.610, 1.813
Modulation transfer function, 1.218-1.220, 1.503, 1.505, 1.506, 1.508, 1.601, 1.629, 1.631, 1.632, 1.638-1.640, 1.645
Monitoring, 1.911, 1.936
Monochromacy, 1.726
Monocular viewing, 1.224, 1.230, 1.232, 1.801, 1.802, 1.913
Motion. *See* Self-motion; target motion
Motion detection, 1.807
Motion in depth, 1.229
Motor fusion, 1.809, 1.810
Moving surround, 1.924
Munsell color system, 1.724
Myopia, 1.204
Myopia, empty field, 1.223, 1.239
Myopia, instrument, 1.223
Myopia, night, 1.223, 1.227, 1.228
Nearsightedness, 1.204, 1.223, 1.227
Neural quantum theory, 1.657
Neural summation, 1.801
Night myopia, 1.223, 1.227, 1.228
Night vision, 1.227, 1.612
Nystagmatic gain, 1.910
Nystagmus, 1.901, 1.909, 1.919-1.922, 1.924, 1.926, 1.929, 1.930, 1.957, 1.958. *See also* Optokinetic nystagmus, postrotary nystagmus, quick phase nystagmus, slow phase nystagmus, vestibular nystagmus
Objective, 1.105
Oblique effect, 1.634
Oblique muscles, 1.901, 1.902
Ocular, 1.105
Ocular media, 1.201, 1.202
Ocular transmissivity, 1.202
Oculogyral illusion, 1.921
Oculomotor control, 1.910
Oculomotor disturbances, 1.923
Onset asynchrony, 1.608
Optical constants, 1.210
Optical reference system, 1.238
Optical transfer function, 1.218-1.220
Optics, of the eye, 1.201-1.240
Optokinetic nystagmus, 1.910, 1.918, 1.921, 1.924, 1.925, 1.928, 1.958
Optokinetic reflex, 1.926, 1.959
Orientation. *See* Spatial Orientation; visual orientation
OSA color system, 1.725
Otoliths, 1.957
Parallel visual processing, 1.653, 1.654
Pattern detection, 1.509, 1.628, 1.629, 1.630-1.632, 1.634-1.645, 1.647, 1.650, 1.651
Pattern perception, 1.602, 1.648, 1.649
Pattern resolution, 1.609, 1.644
Perceptual adaptation, 1.927
Perceptual organization, 1.714
Perifovea, 1.939
Perimetry, 1.235-1.237
Peripheral vision, 1.235-1.237, 1.301, 1.307, 1.308, 1.405, 1.408, 1.411, 1.633, 1.635-1.637, 1.956
Phantom color, 1.719
Phase lag, 1.939
Phoria, 1.809, 1.810, 1.902
Photometric units, 1.104
Photometry, 1.102, 1.108-1.110
Photopic vision, 1.103, 1.301, 1.302, 1.405, 1.611, 1.939
Point-spread function, 1.213-1.215, 1.218
Polar coordinate system, 1.238
Position constancy, visual, 1.907, 1.928
Position uncertainty, 1.627
Postrotary nystagmus, 1.923, 1.958
Practice, 1.603, 1.622
Probability summation, 1.814
Probit analysis, 1.657
Protan, 1.726
Protanomaly, 1.726
Protanopia, 1.726
Pseudoscopic display, 1.812
Psychometric function, 1.657
Psychophysical method, 1.656
Pulse target, 1.511, 1.512
Pupil, 1.105, 1.203, 1.209
Pupil-aperture function, 1.218
Pupillary reflex, 1.232-1.234
Pupil size, 1.106, 1.224, 1.232-1.234, 1.603, 1.614, 1.638
Pupil size, effective, 1.111
Purity discrimination, 1.726
Purkinje image, 1.904
Purkinje shift, 1.304
Purple line, 1.722
Pursuit eye movements, 1.905, 1.906, 1.915, 1.918, 1.924, 1.932, 1.938, 1.940-1.942, 1.945, 1.947. *See also* Smooth pursuit eye movements; tracking eye movements
Quick function, 1.657
Quick-phase nystagmus, 1.922
Radiance, 1.104
Radiant flux, 1.104
Radiometric units, 1.104
Ranking method, 1.656
Rating scales, 1.656
Rectangular coordinate system, 1.238
Rectus muscles, 1.901, 1.902
Reduction defect, 1.726
Reflectance, 1.721
Refraction, 1.201, 1.204-1.206, 1.209-1.211, 1.222-1.231
Retina, 1.201, 1.301
Retinal eccentricity. *See* Retinal location, visual field location
Retinal feedback, 1.937
Retinal illuminance, 1.105, 1.106
Retinal image, 1.203-1.206, 1.209, 1.211, 1.212, 1.214-1.221, 1.240, 1.904
Retinal image disparity, 1.949-1.956, 1.959
Retinal image stabilization, 1.910, 1.917, 1.919-1.921, 1.928
Retinal location, 1.216, 1.305-1.307, 1.504, 1.611, 1.612, 1.635-1.637, 1.705, 1.934, 1.939, 1.941. *See also* Visual field location
Retinal rivalry, 1.804-1.807
Retinal size, 1.240
Riccio's law, 1.308
Rods, 1.301, 1.302
Rod vision, 1.633. *See also* Scotopic vision
Rotation, body, 1.958
Rotation, eye, 1.207
Rotation, head, 1.917, 1.919, 1.920, 1.922, 1.923, 1.927, 1.928, 1.960
Saccadic eye movements, 1.905-1.909, 1.915, 1.916, 1.922, 1.931-1.937, 1.939, 1.942, 1.946, 1.959

- Saccadic eye movements, corrective, 1.935, 1.936, 1.946
- Saccadic latency, 1.915, 1.935, 1.937
- Saccadic drift, 1.916
- Saccadic velocity, 1.933
- Saturation, 1.703, 1.706-1.708, 1.710, 1.722
- Scotopic vision, 1.103, 1.227, 1.301, 1.302, 1.306, 1.308, 1.405, 1.612, 1.633
- Selective adaptation, 1.626, 1.651
- Self-motion, 1.617, 1.619
- Self-rotation, 1.924, 1.958
- Semi-circular canals, 1.910, 1.921
- Sensitivity. *See* Visual sensitivity
- Shape, 1.643
- Signal detection theory, 1.656, 1.657
- Simulation, 1.927
- Simultaneous brightness contrast, 1.713, 1.714
- Simultaneous color contrast, 1.716, 1.717
- Single vision, 1.231, 1.804-1.806
- Size, 1.240, 1.305, 1.307, 1.308, 1.403, 1.406, 1.408-1.410, 1.501, 1.506, 1.507, 1.509, 1.511, 1.625, 1.626, 1.628-1.632, 1.634-1.636, 1.638-1.640, 1.642, 1.645, 1.647, 1.650, 1.707
- Size discrimination, 1.648, 1.649
- Slow-phase nystagmus, 1.922
- Smooth pursuit eye movements, 1.939-1.947. *See also* Pursuit eye movements
- Snellen acuity, 1.602
- Spatial contrast, 1.713, 1.715
- Spatial disorientation, 1.921, 1.927
- Spatial filtering, 1.626, 1.644, 1.650-1.654
- Spatial frequency analysis, 1.601
- Spatial frequency difference threshold, 1.649
- Spatial frequency discrimination, 1.648, 1.649, 1.807
- Spatial interactions, 1.651
- Spatial orientation, 1.620, 1.628, 1.634, 1.652, 1.923, 1.929
- Spatial orientation discrimination, 1.807
- Spatial orientation selectivity, 1.652
- Spatial orientation sensitivity, 1.607
- Spatial resolution, 1.410, 1.602-1.608, 1.610-1.623, 1.643. *See also* Visual acuity
- Spatial sensitivity, 1.601-1.657
- Spatial separation, 1.609
- Spatial summation, 1.305, 1.307, 1.308, 1.403, 1.408, 1.409, 1.624, 1.625
- Spatial uncertainty, 1.627
- Spectral distribution, 1.102
- Spectral radiance, 1.707
- Spectral radiance distribution, 1.722
- Spectral reflectance, 1.108
- Spectral sensitivity, 1.109, 1.110, 1.302, 1.304, 1.701
- Spectral transmittance, 1.108, 1.202
- Spectrum, visible, 1.101
- Spectrum locus, 1.722
- Spherical aberration, 1.211
- Spherical refractive error, 1.204
- Square-wave jerks, 1.914
- Stabilization, 1.926, 1.958
- Stabilization, of visual image. *See* Retinal image stabilization
- Staircase method, 1.656
- Step-by-step brightness matching, 1.109
- Stereoacuity, 1.615, 1.952
- Stereopsis, 1.950, 1.951
- Stereoscope, 1.812
- Stevens' power law, 1.720
- Stiles-Crawford effect, 1.106, 1.111
- Subjective color, 1.719
- Subthreshold summation, 1.652
- Superior oblique muscle, 1.902
- Surround configuration, 1.506
- Target acquisition, 1.603-1.606, 1.611-1.613, 1.615, 1.616, 1.618, 1.620, 1.621, 1.918, 1.922, 1.925, 1.931, 1.936, 1.939, 1.941, 1.945, 1.946, 1.949. *See also* Target detection
- Target detection, 1.404, 1.509, 1.511, 1.512, 1.624-1.627, 1.657, 1.807, 1.814. *See also* Target acquisition
- Target motion, 1.603, 1.617-1.622, 1.624, 1.637, 1.638, 1.943, 1.947, 1.948
- Telescope, 1.105
- Telestereoscope, 1.812
- Temporal sensitivity, 1.501-1.513
- Temporal frequency, 1.510, 1.628
- Temporal modulation, 1.502-1.510, 1.513
- Temporal summation, 1.305, 1.402, 1.409, 1.512, 1.624
- Test patterns, visual, 1.602
- Texture, 1.707
- Three-dimensional displays, 1.615, 1.950-1.956
- Tint, 1.706, 1.708
- Torsion, ocular, 1.901, 1.903, 1.959
- Torsional eye movements, 1.905, 1.956, 1.957, 1.959
- Tracking eye movements, 1.925, 1.939-1.944, 1.946, 1.947. *See also* Pursuit eye movements
- Tracking in depth, 1.949
- Training, 1.925
- Transfer function. *See* Modulation transfer function
- Tremor, ocular, 1.912
- Trichromacy, 1.702, 1.722, 1.726
- Tristimulus values, 1.702, 1.722
- Tritan, 1.726
- Tritanomaly, 1.705
- Tritanopia, 1.726
- Troland, 1.106
- Uncertainty, 1.627
- Uniform lightness scale, 1.721
- Utricles, 1.957
- Utricular discrimination, 1.811
- Vector model of identification, 1.655
- Velocity, image, 1.913
- Vergence eye movements, 1.231, 1.808-1.810, 1.905, 1.913, 1.950-1.956
- Vernier acuity, 1.607, 1.608, 1.610, 1.611. *See also* Visual acuity
- Vernier offset discrimination. *See* Vernier acuity
- Vertical misalignment, 1.607, 1.608, 1.610
- Vertical rectus muscle, 1.902
- Vertigo, 1.917, 1.921, 1.923, 1.924, 1.927, 1.929
- Vestibular function, 1.918, 1.957, 1.958
- Vestibular gain, 1.928
- Vestibular illusions, 1.923, 1.930
- Vestibular nystagmus, 1.918-1.920, 1.922, 1.926, 1.928-1.930. *See also* Nystagmus
- Vestibulo-ocular interaction, 1.923, 1.938, 1.960
- Vestibulo-ocular reflex, 1.910, 1.913, 1.917, 1.919, 1.920, 1.922, 1.926, 1.927, 1.929
- Video displays, 1.618, 1.620
- Viewing comfort, 1.207
- Viewing distance, 1.224, 1.228-1.231, 1.234, 1.603, 1.615, 1.616
- Vignetting, 1.207
- Visible spectrum, 1.101
- Visual acuity, 1.213-1.215, 1.227, 1.410, 1.602-1.623, 1.643, 1.644
- Visual angle, 1.240
- Visual detection, 1.653, 1.654. *See also* Pattern detection; target detection
- Visual direction, 1.912, 1.933, 1.938
- Visual distortion, 1.927
- Visual field, 1.235-1.237
- Visual field location, 1.216, 1.305-1.307, 1.504, 1.603, 1.611, 1.612, 1.624, 1.628, 1.635-1.637, 1.705. *See also* Retinal location
- Visual image, 1.203-1.206, 1.209, 1.211, 1.212, 1.214-1.221, 1.240
- Visually coupled systems, 1.918, 1.960
- Visual noise, 1.640
- Visual orientation, 1.959
- Visual pathology, 1.102
- Visual processing, parallel, 1.653, 1.654
- Visual search, 1.935, 1.936
- Visual sensitivity, 1.305-1.308, 1.406-1.409, 1.411, 1.412. *See also* subentries below and Spatial sensitivity; temporal sensitivity
- Visual sensitivity, changes in, 1.401-1.413
- Visual sensitivity, to light, 1.301-1.309
- Visual tracking, 1.229, 1.617-1.622
- Visual tracking, anticipatory, 1.621
- Visual-vestibular interaction, 1.920, 1.921, 1.925, 1.927, 1.930
- Vitreous humor, 1.210
- Volumetric display, 1.812
- Von Kries coefficients, 1.710
- Wavelength, 1.101, 1.102, 1.109, 1.302, 1.305, 1.406, 1.407, 1.603, 1.606, 1.706, 1.707, 1.722
- Wavelength discrimination, 1.704
- WDW normalization, 1.702
- Weber-Fechner law, 1.401
- Weber's law, 1.502
- Yes/no procedure, 1.657

Glossary

- Abduction.** The outward rotation of an eye away from the midline.
- Absolute threshold.** The amount of stimulus energy necessary to just detect the stimulus. For luminance, it is the minimum perceptible luminance (photometric brightness) when the eye is completely dark-adapted. Usually taken as the value associated with some specified probability of stimulus detection (typically 0.50 or 0.75).
- Accommodation.** A change in the thickness of the lens of the eye (which changes the eye's focal length) to bring the image of an object into proper focus on the retina. (CRef. 1.222)
- Achromatic.** (1) Characterized by an absence of chroma or color. (2) In optics, corrected to have the same focal length for two selected wavelengths.
- Adaptation.** (1) A change in the sensitivity of a sensory organ to adjust to the intensity or quality of stimulation prevailing at a given time (also called **sensory adaptation**); adaptation may occur as an increase in sensitivity (as in dark adaptation of the retina) or as a decrease in sensitivity with continued exposure to a constant stimulus. (2) A semi-permanent change in perception or perceptual-motor coordination that serves to reduce or eliminate a registered discrepancy between or within sensory modalities or the errors induced by this discrepancy (also called **perceptual adaptation**). (CRef. 5.1101)
- Adaptometer.** An instrument for determining the amount of retinal adaptation or the time course of adaptation by measuring changes in the observer's threshold for light. Adaptometers are most frequently designed to measure dark adaptation.
- Alpha wave.** Oscillations in the electrical potential of the cortex of the brain that have a frequency of 6-14 Hz and characteristically occur when the individual is awake and relaxed. The waves are generally measured between one electrode taped to the scalp on the back of the head and another, more distant electrode attached, e.g., to the mastoid.
- Amblyopia.** Low or reduced visual acuity not correctable by refractive means and not attributable to detectable structural or pathological defects. Clinically judged present if Snellen acuity is 20/30 or worse after refractive correction, or if acuity is significantly less in one eye than in the other.
- Aqueous humor.** The clear, watery fluid that fills the front chamber of the eye (the space between the cornea and the crystalline lens) and supplies oxygen and nutrients to the cornea and lens. (CRef. 1.201)
- Artificial pupil.** An aperture (smaller than the eye pupil in diameter) in a disc or diaphragm mounted in front of the eye and used to control the amount of light entering the eye. A small artificial pupil (<2 mm) provides the eye with a virtually infinite depth of field.
- Astigmatism.** In the eye, refractive error due to unequal refraction of light in different meridians, caused by nonuniform curvature of the optical surfaces of the eye, especially the cornea. (CRef. 1.201)
- Binocular.** (1) Pertaining to, affecting, or impinging upon both eyes; sometimes used to imply the identity of both eyes' views (see also **dichoptic**). (2) Employing both eyes at once, with each eye's view contributing to the final percept.
- Binocular suppression.** Decrease or loss of visibility of a portion or all of one eye's view due to stimulation of the same portion of the other eye. Binocular suppression is most clearly demonstrated when the two eyes are presented with conflicting information (such as different colors or different orientation of contours) on corresponding parts of the retinas. (CRef. 1.804)
- Blackbody source.** See **blackbody radiator**.
- Blackbody radiator.** An ideal surface that completely absorbs all radiant energy of any wavelength incident upon it (and therefore appears black) and emits radiant energy of a spectral distribution that varies with absolute temperature according to Planck's radiation formula; also known as a **Planckian radiator** or an **ideal radiator**. (CRef. 1.107)
- Blind spot.** The region of the retina where the optic nerve exits the eye; this region contains no visual receptors and is therefore insensitive to light; also known as the **optic disc**.
- Bloch's law.** A law stating that, for brief targets (less than ~100 msec), the threshold intensity for detecting a target varies inversely with exposure duration; i.e., $I = k/T$, where I is the light intensity of the target, T is exposure duration, and k is a constant. In other words, target lights with equal energy (or equal numbers of quanta) are equally detectable ($I \times T = k$).
- Brightness.** The subjective attribute of light sensation by which a stimulus appears to be more or less intense or to emit more or less light. Brightness can range from very bright (brilliant) to very dim (dark). In popular usage, brightness implies higher light intensities, dimness the lower intensities.
- Brightness induction.** See **induction**.
- Candela.** A unit of luminous intensity equal to the luminous intensity in a direction perpendicular to the surface of 1/60 of 1 square centimeter of a blackbody radiator at the solidification temperature of platinum. Sometimes also called **candle** or **new candle**.
- Chroma.** (1) The attribute of color perception representing the degree to which a chromatic color differs from an achromatic (gray) color of the same lightness. (2) The dimension of the Munsell color system corresponding most closely to saturation.
- Chromatic.** Having hue; colored; i.e., appearing different in quality from a neutral gray of the same lightness value.
- Chromatic aberration.** Image degradation in an optical system, resulting from unequal refraction of light of different wavelengths; commonly manifested in simple optical systems as colored fringes on the border of an image. (CRef. 1.212)
- Chromatic induction.** See **induction**.
- Chromaticity.** The quality of a color characterized by dominant or complementary wavelength (hue) and purity (saturation) but not brightness or lightness.
- Chromaticity coordinates.** The proportions of each of the three standard primaries required to match a given color, expressed as the ratio of the amount of one primary to the total amount of all three. The chromaticity coordinates are designated as x , y , and z in the colorimetric system of the CIE (Commission Internationale de l'Éclairage).
- Chromaticity diagram.** The two-dimensional diagram produced by plotting two of the three chromaticity coordinates (x , y , z) against one another. The most widely used is the (x , y) diagram of the CIE (Commission Internationale de l'Éclairage), plotted in rectangular coordinates. (CRef. 1.722)
- CIE.** Commission Internationale de l'Éclairage (International Commission on Illumination), an international organization devoted to the study and advancement of the science of illumination that has developed a number of international standards in photometry and colorimetry.
- CIE observer.** A hypothetical observer with standard color vision defined by the color-matching behavior embodied in the **RGB** and **XYZ** systems of the CIE (Commission Internationale de l'Éclairage).

1.0 Visual Acquisition of Information

- Circularvection.** Illusory self-rotation induced by rotating scenes.
- Color assimilation.** A form of chromatic induction in which the difference between adjacent colors diminishes and it appears as though the color of one field spreads into and combines with the color of another field. Also known as **Bezold spreading effect**. (CRef. 1.718)
- Colorimetric purity.** The ratio of the luminance of the spectrally pure component of a mixture to the luminance of the mixture itself. (CRef. 1.703)
- Color temperature.** The temperature of a blackbody radiator (in degrees Kelvin) that has the same chromaticity as a given color sample or source. (CRef. 1.107)
- Color wheel.** A colored disk consisting of two or more disks of different colors cut along a single radius, then interleaved and overlapped to provide any desired ratio of exposure; the composite disk is rotated rapidly to produce a perceptual mixture of the colors.
- Complementary wavelength.** The wavelength designated by the point on the spectrum locus of a chromaticity diagram that lies on the opposite side of the achromatic point, in a straight line with the wavelength in question; i.e., the wavelength that, when mixed with the wavelength in question, yields white.
- Complex conjugate.** A quantity that has the same real part as a second quantity but an imaginary part with the opposite sign; e.g., $a - ib$ is the complex conjugate of $a + ib$, where $i = \sqrt{-1}$.
- Cone.** A cone-shaped photoreceptor in the retina of the eye; cones are the only receptors in the fovea and their density falls off rapidly with distance from the fovea. Cones function only at photopic (daylight) levels of illumination; they are responsible for color vision and fine visual resolution. (CRefs. 1.201, 1.301)
- Contrast.** The difference in luminance between two areas. In the research literature, contrast is expressed mathematically in several nonequivalent ways (CRef. 1.601). (See also **contrast ratio**, **Michelson contrast**.)
- Contrast ratio.** A mathematical expression for contrast (luminance difference between two areas); defined in this way, the contrast of one area with respect to a second is given as L_1/L_2 , or as $(L_2 + L_1)/L_2$, where L_1 is the luminance of the first area and L_2 is the luminance of the second area. (CRef. 1.601)
- Contrast sensitivity.** The ability to perceive a lightness or brightness difference between two areas; generally measured as the reciprocal of the contrast threshold. Contrast sensitivity is frequently measured for a range of target patterns differing in value along some dimension such as pattern element size and portrayed graphically in a **contrast sensitivity function** in which the reciprocal of contrast threshold is plotted against pattern spatial frequency or against visual angle subtended at the eye by pattern elements (such as bars).
- Contrast threshold.** The contrast associated with the minimum perceptible difference in luminance between two areas, often measured in terms of the luminance difference detectable on some specified proportion of trials (generally 0.50).
- Convergence.** Inward rotation of the eyes so that the lines of sight intersect at the distance of the object being viewed and the images of the object in the two eyes fall on corresponding portions of the two retinas. (CRef. 1.808)
- Convergence angle.** The angle formed between the lines of sight of the two eyes when the eyes are fixated on a point in space. (CRef. 1.808)
- Cornea.** The transparent structure forming the front part of the fibrous coat of the eyeball and covering the iris and pupil. (CRef. 1.201)
- Corollary discharge.** That component of an internally generated command (outflow) signal (such as a signal to move the eyes) that is theoretically used for comparison with the inflowing sensory signal in determining perception.
- Dark adaptation.** Adjustment of the eye to low levels of illumination which results in increased sensitivity to light.
- Dark focus.** The distance to which the eye is focused in the dark.
- Decibel.** A standard unit for expressing the ratio between the power levels of two acoustic or electrical signals. The decibel is sometimes used in vision to denote the ratio between two stimulus magnitudes, such as the threshold contrast for a given target under two different experimental conditions. One decibel is taken to be $10 \log p_1/p_2$ (where p_1 and p_2 are the magnitudes of the two stimuli).
- Dependent variable.** The response to a stimulus presentation measured by the investigator to assess the effect of an experimental treatment or independent variable in an experiment; for example, the investigator might measure the absolute visual threshold (dependent variable) for light targets of different diameters to assess the effects of target size (independent variable). (Compare **independent variable**.)
- Detection threshold.** See **absolute threshold**; **threshold**.
- Dichoptic.** Referring to viewing conditions in which the visual displays to the right and left eyes are not identical but differ with respect to some property (such as luminance or placement of contours).
- Difference threshold.** The least amount by which two stimuli must differ along some dimension (such as luminance or wavelength) to be judged as nonidentical. Usually taken as the difference value associated with some specified probability of detecting a difference (typically 0.50 or 0.75).
- Diopter.** (1) A measurement unit expressing the refractive power of a lens and equal to the reciprocal of the focal length in meters. (2) A measurement unit expressing the vergence of a bundle of light rays equal to the reciprocal of the distance to the point of intersection of the rays in meters (taking a positive value for diverging rays and a negative value for the converging rays); the unit is often used to express the distance to an object being viewed, since it indicates the amount of eye accommodation necessary to bring the object into proper focus on the retina. (3) A measurement unit expressing the strength of a prism and equal to 100 times the tangent of the angle through which light rays are bent (generally called **prism diopter**).
- Diplopia.** See **double vision**.
- Dominant wavelength.** The spectral wavelength that will match a given sample of color when mixed with a suitable proportion of white and adjusted appropriately in intensity.
- Double vision.** A condition in which a single object appears as two objects because the images of it in the left and right eyes do not fall on corresponding portions of the retinas; also called **diplopia**.
- Electroencephalogram.** A graphical recording of changing electrical potentials due to the activity of the cerebral cortex, measured from electrodes located on the scalp.
- Emmetropia.** Optically normal vision; i.e., the refractive condition of the normal eye in which an object at infinity is brought accurately to a focus on the retina when accommodation is relaxed. (Compare **farsightedness**; **nearsightedness**.)
- Entrance pupil.** The image of the aperture stop formed by the portion of an optical system on the object side of the stop. The dark aperture seen when looking into a person's eye is the entrance pupil of the eye, which is larger and closer to the cornea than the real pupil.
- Esophoria.** A tendency for one or both eyes to turn inward in the absence of adequate fusion contours. (CRef. 1.809)
- Exophoria.** A tendency for one or both eyes to turn outward in the absence of adequate fusion contours. (CRef. 1.809)
- Extended source.** A light source that, unlike a point source, subtends a non-zero angle at the observer's eye. In practice, considered to be any source whose size is larger than one-tenth the distance from the observer to the source.
- Factorial design.** An experimental design in which every level or state of each independent variable is presented in combination with every level or state of every other independent variable.

Farsightedness. An error of refraction in which parallel rays of light from an object at infinity are brought to a focus behind the retina when accommodation is relaxed. In some individuals with this condition, accommodative power may be sufficient to achieve good focus of objects at all distances; others may require corrective lenses to achieve proper focus of very near objects. Also known as **hyperopia** or **hypermetropia**. (CRef. 1.204)

Fixation disparity. Convergence of the eyes to a plane in front of or behind the intended plane of fixation.

Fixation distance. The distance to which the eyes are converged.

Fixation point. The point in space toward which one or both eyes are aimed. In normal vision, the image of the fixation point falls on the fovea.

Fourier analysis. The representation of a complex periodic waveform as the superposition of a series of single sinusoidal components according to Fourier's theory.

Fovea. A pit in the center of the retina (approximately 1-2 deg of visual angle in diameter) where the density of cones is highest and visual acuity is greatest.

Gaussian distribution. A probability density function that approximates the frequency distribution of many random variables in biological or other data (such as the proportion of outcomes taking a particular value in a large number of independent repetitions of an experiment where the probabilities remain constant from trial to trial). The distribution is symmetrical, with the greatest probability densities for values near the mean and decreasing densities at both larger and smaller values, and has the form

$$f(x) = \frac{1}{\sigma\sqrt{2\pi}} e^{-\frac{1}{2}\left(\frac{x-\mu}{\sigma}\right)^2}$$

where $f(x)$ is the probability density for the value x in the distribution, μ is the mean value, and σ is the standard deviation. Also called **normal distribution** or **normal probability distribution**.

Heterochromatic brightness matching. A procedure in which a fixed-radiance reference light of known luminance is presented adjacent to a comparison field with a different wavelength composition. The observer adjusts the radiance of the comparison field until both appear of equivalent brightness. The procedure is used to measure relative sensitivity to light of different wavelengths. (CRef. 1.109)

Heterochromatic flicker photometry. A procedure in which a reference light of fixed luminance is alternated in time with a coextensive comparison light with a different wavelength composition. The observer adjusts the radiance of the comparison light to eliminate or minimize the sensation of flicker. The procedure is used to measure relative sensitivity to light of different wavelengths. (CRef. 1.109)

Homatropine. An alkaloid (oxytoluy-tropeine) applied topically to the eye to dilate the pupil and paralyze eye accommodation.

Horizontal axis of Helmholtz. In representing eye position, the horizontal axis connecting the centers of rotation of the two eyes; eye elevation is specified in terms of rotation about this axis.

Ideal radiator. See **blackbody radiator**.

Illuminance. The luminous flux incident per unit area of a surface at any given point on the surface. The most commonly used units of measurement are lux (lumens per m²) and foot candles (fc, or lumens/ft²). (CRef. 1.104)

Increment threshold. See **difference threshold**.

Independent variable. The aspect of a stimulus or experimental environment that is varied systematically by the investigator to determine its effect on some other variable (i.e., the subject's response). For example, the investigator might systematically alter the diameter of a target light to assess the effect of target size (independent variable) on the observer's absolute visual threshold (dependent variable). (*Compare dependent variable.*)

Inducing field. The portion of the visual field acting on and modifying the perception of another portion of the visual field (the induced field or test field).

Induction. Alteration of perception by indirect stimulation.

Lightness or brightness induction is the alteration of the perceived lightness or brightness of a given area due to the presence of a nearby area of different lightness or brightness. **Chromatic or color induction** is the alteration of the perceived hue of a colored area due to the presence of a nearby area with differing chromaticity.

Inferior oblique muscle. One of the six voluntary muscles that move the eyeball. (CRef. 1.901)

Interpupillary distance. The distance between the centers of the pupils of the eyes when the eyes are parallel (converged to optical infinity); also known as **interocular distance**. (CRef. 1.208)

Inverse power function. An exponential function with a negative exponent, e.g., x^{-2} or $1/x^2$.

Inverse square law. A law stating that the illuminance or irradiance from a point source varies as the inverse square of the distance from the source to the observer.

Iris. The circular, pigmented membrane that surrounds the pupil of the eye, located between the cornea and the crystalline lens. (CRef. 1.201)

Just-noticeable difference. The least amount by which two stimuli must differ along a given dimension to be perceived as nonidentical.

Landolt C. An incomplete ring, similar to the letter C in appearance, used as a test object for visual acuity. The thickness of the ring and the break in its continuity are each one-fifth of its overall diameter. The ring is rotated so that the gap appears in different positions and the observer is required to identify the location of the gap. Also called a **Landolt ring** or **Landolt C-ring**. (CRef. 1.602)

Landolt ring. See **Landolt C**.

Lateral rectus muscle. One of the six voluntary muscles that move the eyeball. (CRef. 1.901)

Lateral retinal image disparity. The difference in the relative horizontal position of the visual images of an object on the left and right retinas due to the lateral separation of the eyes. (CRef. 5.905)

Least-squares method. A mathematical method of fitting a curve to a set of quantitative data points in which the sum of the squares of the distances from the points to the curve is minimized.

Lens. A transparent, biconvex, lens-shaped body located immediately behind the iris of the eye; through the action of the ciliary muscle, the shape of the semi-elastic lens can be changed to alter its refractive power and bring the images of objects at different distances to a sharp focus on the retina. (CRefs. 1.201, 1.222)

Light adaptation. The adjustment of the visual system to an increase in illumination in which sensitivity to light is reduced (threshold for light is increased) as illumination is increased.

Lightness. The attribute of visual perception according to which a visual stimulus appears to emit more or less light in proportion to a stimulus perceived as "white." Lightness can range from very light (white) to very dark (black). The physical correlate of lightness is reflectance.

Lightness induction. See **induction**.

Line-spread function. A mathematical description of the relative intensity of light in the optical image of an infinitesimally narrow bright line as a function of distance from the center of the image in a direction perpendicular to the line's length. (CRef. 1.215)

Lumen. A unit of luminous flux equal to the light emitted within a solid angle of unit size by a point source of light with a luminous intensity of 1 candela; i.e., 1 candela per steradian.

1.0 Visual Acquisition of Information

Luminance. Luminous flux reflected or transmitted by a surface per unit solid angle per unit of projected area in a given direction. The most commonly used units of measurement are candelas per meter² (cd/m²), footlamberts (fL), and millilamberts (mL). (CRef. 1.104)

Luminosity. The luminous efficiency (brightness-producing capacity) of radiant energy.

Luminous efficiency. The ratio of the total luminous flux radiated by a source (i.e., radiant flux weighted by the standard spectral luminous efficiency function of the eye) to the radiant flux from the source; usually expressed in terms of lumens/watt. (CRefs. 1.104, 1.110)

Luminous efficiency function. The function describing the relative sensitivity of the eye to light of different wavelengths. (CRef. 1.110)

Luminous flux. The radiant flux from a source weighted by the luminous efficiency function of the eye (i.e., the response of the eye to each wavelength present); usually expressed in terms of lumens. (CRefs. 1.104, 1.110)

Luminous intensity. The light-giving power of a source, measured as the luminous flux per unit solid angle in a given direction and usually expressed in terms of candelas (cd, or lumens/steradian). (CRef. 1.104)

Lux. A unit of illuminance equal to the illumination on a surface 1 meter from a point source of light with a luminous intensity of 1 candela, or 1 lumen per square meter (1 candela per steradian per square meter).

Macula lutea. The central region of the retina, approximately 6-10 deg of visual angle (2-3 mm) in diameter. Marked by yellow pigmentation, it is the region of greatest visual acuity; the fovea is at its center.

Macular. Of or pertaining to the macula lutea.

Masking. A decrease in the detectability of one stimulus due to the presence of a second stimulus (the **mask**) which occurs simultaneously with or close in time to the first stimulus.

Maxwellian view. A uniformly luminous field obtained when a light source is focused on the pupil of the eye. Very high luminances are achievable and the amount of light entering the eye is not affected by pupil size.

Medial rectus muscle. One of the six voluntary muscles that move the eyeball. (CRef. 1.901)

Mesopic. Pertaining to a luminance range intermediate between photopic and scotopic levels at which both the rods and cones function.

Metameric pair. Two lights or targets of different spectral composition that nevertheless appear identical in color.

Method of adjustment. A psychophysical method for determining a threshold in which the subject (or the experimenter) adjusts the value of the stimulus until it just meets some preset criterion (e.g., just appears visible or just appears flickering) or until it is apparently equal to a standard stimulus.

Method of constant stimuli. A psychophysical method of determining a threshold in which the subject is presented with several fixed, discrete values of the stimulus and makes a judgment about the presence or absence of the stimulus or indicates its relation to a standard stimulus (e.g., brighter, dimmer).

Method of limits. A psychophysical method of determining a threshold in which the experimenter varies a stimulus in an ascending or descending series of small steps and the observer reports whether the stimulus is visible or not or indicates its relation to a standard stimulus.

Michelson contrast. A mathematical expression for specifying the contrast of periodic patterns; defined as $(L_{\max} - L_{\min}) / (L_{\max} + L_{\min})$, where L_{\max} and L_{\min} are the maximum and minimum luminances in the pattern. Michelson contrast ranges between 0 and 1. (CRef. 1.601)

Microsaccade. Very small movements or tremors of the eye (2-28 min arc of visual angle) occurring at a variable rate and most typically seen when observers attempt to fixate very accurately.

Minimum angle of resolution. The minimum distance (measured in minutes of arc of visual angle) by which two targets (such as lines or points) must be separated in order to be distinguished as two targets rather than one. (CRef. 1.602)

Minimum visibility. The smallest perceivable target size, typically measured as the width of the narrowest dark line that can be detected at a given distance and luminance level. (CRef. 1.602)

Mirror stereoscope. A device using a system of mirrors to present separate images of an object or scene to the left and right eyes; for appropriately constructed stereograms, the result is a single, fused image appearing to have depth or three-dimensionality. Sometimes called a **Wheatstone stereoscope**.

Monochromatic. Pertaining to or consisting of light of a single wavelength or a very narrow band of wavelengths.

Monocular. Pertaining to, affecting, or impinging upon only one eye.

Munsell value. The dimension of the Munsell color system corresponding to lightness; it ranges from 1 (black) to 10 (white) and is approximately equal to the square root of the reflectance expressed in percent. (CRef. 1.724)

Myopia. See **nearsightedness**.

Nearsightedness. An error of refraction in which parallel rays of light from an object at infinity are brought to a focus in front of the retina when accommodation is relaxed. An individual with this condition will see close objects clearly, but distant objects will not be in sharp focus unless corrective lenses are worn. Also known as **myopia**. (CRef. 1.204)

Neutral density. See **neutral density filter**.

Neutral density filter. A light filter that decreases the intensity of the light without altering the relative spectral distribution of the energy; also known as a **gray filter**.

Nodal points. The points in a lens system, such as the eye, toward which and from which are directed corresponding incident and transmitted rays that make equal angles with the optical axis.

Nystagmus. Involuntary rhythmic movements of the eyes, which generally take the form of a slow drift alternating with a quick movement in the opposite direction.

Optic node. The optical center of the compound lens system of the eye (center of curvature of the cornea in the simple lens equivalent).

Optokinetic nystagmus. Nystagmus induced by viewing a moving object.

Optometer. An instrument for measuring the refractive power and range of vision.

Parafovea. A region of the retina covering approximately 4 deg of visual angle (0.5 mm), immediately surrounding the fovea.

Peripheral vision. Vision in the peripheral (non-foveal) region of the visual field.

Photometric unit. A unit for measuring radiant energy in terms of its effect on vision, as contrasted with radiometric units, which measure energy and power without regard to biological effect.

Photometry. The measurement of light in terms of its effects on vision.

Photopic. Pertaining to relatively high (daytime) levels of illumination at which the eye is light adapted and vision is mediated by the cone receptors. (CRef. 1.103)

Photoreceptor. A receptor such as a rod or cone cell of the eye that is sensitive to light.

Plane of fixation. The plane parallel to the front of the observer's body that contains the point of convergence (or fixation) of the eyes.

Point source. A light source (such as a star) that subtends an extremely small angle at the observer's eye. In practice, considered to be any source whose diameter is less than one-tenth the distance of the observer from the source.

- Postrotary nystagmus.** Nystagmus caused by decelerative stimulation of the vestibular system after the cessation of head rotation; the eye movements are opposite in direction to the nystagmus induced by the head rotation itself.
- Primary line of sight.** The line connecting the point of fixation in the visual field with the center of the entrance pupil (and center of the fovea) of the fixating eye.
- Probability summation.** The increase in the probability of detecting a stimulus due to an increase in the number of independent opportunities for detection on a given trial (as by viewing with two eyes or processing by multiple independent sensory mechanisms). (CRef. 1.814)
- Probit analysis.** A regression-like maximum-likelihood procedure for finding the best-fitting ogive function for a set of binomially distributed data. Originally developed in connection with pharmacological and toxicological assays to compute the lethal or effective dose (dosage affecting 50% of treated organisms); the procedure has also been applied in psychophysical studies in analyzing all-or-nothing (yes/no) responses to compute the 50% threshold (stimulus level eliciting a given response on 50% of trials) and its confidence limits.
- Psychometric function.** A mathematical or graphical function expressing the relation between a series of stimuli that vary quantitatively along a given dimension, and the relative frequency with which a subject answers with a certain category of response in judging a particular property of the stimulus (e.g., "yes" and "no" in judging whether a given stimulus is detected, or "less than," "equal to," and "greater than" in comparing the stimulus with a standard stimulus). (CRef. 1.657)
- Randomized design.** An experimental design in which the various levels of the independent variable are presented in random order within a given block of trials or experimental session.
- Reaction time.** The time from the onset of a stimulus to the beginning of the subject's response to the stimulus by a simple motor act (such as a button press).
- Reflectance.** The ratio of reflected radiant flux to incident flux; the portion of incident light reflected.
- Resolution threshold.** A measure of the ability to resolve fine detail; determined in a variety of ways, e.g., as the minimum separation between two lines required for them to be seen as double rather than single, or as the smallest width of bars in a bar pattern that allows the patterns to be distinguished from a uniform field.
- Retina.** The membranous structure lining the inside of the eyeball which contains the photoreceptors (rods and cones) that mediate vision.
- Retinal eccentricity.** Distance from the center of the fovea to an image on or to an area of the retina, generally expressed in angular terms; corresponds to the distance in the visual field from the fixation point to a given object or point in the field.
- Retinal image disparity.** See lateral retinal image disparity.
- Ricco's law.** A law stating that, for small targets, the threshold intensity for detecting a target varies inversely with the size of the target; i.e., $I = k/A$, where I is the light intensity of the target, A is the target area, and k is a constant. In other words, target lights with equal energy (or equal numbers of quanta) are equally detectable ($I \times A = k$). (CRef. 1.308)
- Rod.** A rod-shaped photoreceptor in the retina of the eye; rods are distributed only outside the fovea and are responsive at low levels of illumination. (CRefs. 1.201, 1.301)
- Saccade.** A short, abrupt movement ("jump") of the eyes, as in shifting fixation from one point to another (such as occurs in reading).
- Saturation.** The attribute of color perception representing the degree to which a chromatic color differs from an achromatic color regardless of their lightnesses. For example, a red with low saturation is pink.
- Scotopic.** Pertaining to relatively low (nighttime) levels of illumination at which the eye is dark adapted and vision is mediated by the rod receptors. (CRef. 1.103)
- Sensitivity.** In a general sense, the ability to detect stimulation; in psychophysical studies, refers in particular to the ability to be affected by and respond to low-intensity stimuli or to slight stimulus differences; commonly expressed as the reciprocal of measured threshold.
- Signal detection theory.** A theory which holds that performance on a detection task is a function of both the detectability of the signal (or the sensitivity of the observer) and the observer's criterion or response bias in reporting the signal. (CRef. 7.420)
- Simultaneous contrast.** Alteration in the appearance of one stimulus due to the simultaneous presence of another nearby stimulus that differs from it along some dimension (such as lightness or color), in such a way that the difference between the two stimuli is accentuated. **Simultaneous lightness contrast:** alteration in the lightness of one stimulus due to the presence of a nearby stimulus of different lightness. (CRef. 3.114) **Simultaneous color contrast:** alteration in the perceived hue of one stimulus due to the presence of an adjacent stimulus of different hue. (CRef. 1.717)
- Sine-wave.** A periodic waveform in which the amplitude at each point across time or space varies according to a sine function.
- Sine-wave grating.** A bar pattern in which some property (generally luminance) varies with spatial position according to a sine function in a direction perpendicular to the bar. (CRef. 1.601)
- Sinusoidal.** Varying according to a sine function.
- Sloan letter chart.** (1) A chart for measuring visual acuity that contains ten capital letters graded in size in equal logarithmic steps and chosen to be equal in difficulty to each other and to the Landolt ring. There is one chart for testing vision at 20 feet and another for testing at 16 inches. (2) A set of nine cards containing samples of discursive text that is used to test individuals with subnormal vision to determine the magnification required to read newsprint.
- Snellen acuity.** Visual acuity measured using a standard chart containing rows of letters of graduated sizes and expressed as the distance at which a given row of letters is correctly read by a specific individual compared to the distance at which the letters can be read by a person with clinically normal eyesight. For example, an acuity score of 20/50 indicates that the tested individual can read only at a nearer distance of 20 ft the letters read by a normally sighted person at 50 ft. (CRef. 1.602)
- Snellen letter chart.** A chart for measuring visual acuity consisting of a standard set of letters in rows of graduated size. (CRef. 1.602)
- Spatial frequency.** For a periodic target such as a pattern of equally spaced bars, the reciprocal of the spacing between bars (i.e., the width of one cycle, or one light bar plus one dark bar), generally expressed in cycles per millimeter or cycles per degree of visual angle.
- Spatial summation.** The combining of the visual response to light impinging simultaneously on different regions of the retina. (See also Ricco's law.)
- Spectral radiant power distribution.** The radiant power at each wavelength along a given portion of the electromagnetic radiation spectrum.
- Spectral sensitivity.** The relative sensitivity of the eye to light of different wavelengths.
- Spectrum locus.** The line on a chromaticity diagram on which fall the chromaticities of all wavelengths of the visible spectrum.
- Split-half reliability method.** A method of measuring test-retest reliability in which, for speed and convenience, the coefficient of correlation is calculated between performance on the first half of a test and performance on the second half of the test for a group of subjects, rather than between performance on two separate repetitions of the test. (See test-retest reliability.)

1.0 Visual Acquisition of Information

Square wave. A rectangular waveform whose amplitude periodically shifts instantaneously between two discrete values.

Staircase procedure. A variant of the method of limits for determining a psychophysical threshold in which the value of the stimulus on a given trial is increased or decreased, depending on the observer's response on the previous trial or group of trials.

Standard deviation. The square root of the average squared deviation from the mean of the observations in a given sample. It is a measure of the dispersion or scatter of scores or observations in a sample.

Standard error of the mean. The standard deviation of the sampling distribution of the mean; mathematically, the standard deviation of the given data sample divided by the square root of one less than the number of observations. It describes the variability of the mean over repeated sampling.

Standard luminous efficiency. Luminous efficiency as defined by the CIE (Commission Internationale de l'Éclairage).

Standard normal deviate. A test score or experimental measurement or datum point expressed in terms of the number and direction of standard deviation units from the mean of the sample distribution. Also called **standard score** or **z-score**.

Stereoacuity. The ability to discriminate depth or distance on the basis of lateral retinal image disparity; usually expressed as the smallest detectable difference in depth of two targets.

Stereopsis. Visual perception of depth or three dimensionality; commonly used to refer specifically to depth arising from lateral retinal image disparity.

Stereoscope. An instrument used to present a separate visual display to each eye. Typically utilizes a system of mirrors, prisms, or lenses to present two specially constructed flat pictures (one to each eye) that, when combined by the visual system, give the impression of solidity or three-dimensionality.

Stereoscopic. Of or pertaining to stereopsis.

Stiles-Crawford effect. The decrease in the apparent brightness (luminous efficiency) of a narrow beam of light entering the eye near the edge of the pupil relative to the brightness of an identical beam entering in the center of the pupil. (CRef. 1.111)

Superior oblique muscle. One of the six voluntary muscles that move the eyeball. (CRef. 1.901)

Suppression. See **binocular suppression**.

Temporal summation. The integration over time of the visual response to a stimulus falling on a given retinal region or the combining of the responses to two or more stimuli impinging consecutively on the same retinal region. (See also **Bloch's law**.)

Test-retest reliability. Consistency in yielding the same or similar scores on repeated administrations of a given test, measured by computing the coefficient of correlation between performance on two successive presentations of the same test for a group of subjects.

Threshold. A statistically determined boundary value along a given stimulus dimension that separates the stimuli eliciting one response from the stimuli eliciting a different response or no response (e.g., the point associated with a transition from "not visible" to "visible" or from "greater than" to "equal to" or "less than"). (CRef. 1.657) (See also **absolute threshold**; **difference threshold**; **resolution threshold**.)

Tristimulus colorimeter. An instrument for measuring color which allows a given test color to be specified in terms of the relative proportions of three primary colors (e.g., red, green, and blue) which, when additively mixed, give the same hue sensation as the test color.

Troland. A unit expressing light intensity at the retina equal to the illumination produced per square millimeter of pupil area

by viewing a surface with a luminance of 1 candela per square meter. Originally called **photon**. (CRef. 1.106)

T-test. A statistical test used to compare the mean of a given sample with the mean of the population from which the sample is drawn or with the mean of a second sample in order to determine the significance of an experimental effect (i.e., the probability that the results observed were due to the experimental treatment rather than to chance). Also known as **Student's t-test**.

Two-alternative forced-choice paradigm. An experimental procedure in which the subject is presented on each trial with one of two alternative stimuli and must indicate which stimulus occurred; a response must be made on each trial even if the subject must guess. Commonly referred to as a "criterion-free" method of determining sensitivity.

Uniform chromaticity scale. A chromaticity diagram on which all pairs of just-noticeable different colors of equal luminance are represented by pairs of points separated by approximately equal distances.

Vernier acuity. The ability to discern the colinearity or lack of alignment of two parallel lines placed one above the other, as in reading a vernier scale; frequently expressed in terms of the smallest detectable misalignment in seconds of arc of visual angle. (CRef. 1.602)

Vernier adjustment. Adjustment of the lateral position of one of two vertical lines placed one above the other until the two appear vertically aligned. The procedure is used to measure vernier acuity.

Vestibular nystagmus. Nystagmus produced by stimulation of the vestibular system (as by head rotation) or by disease of or damage to the vestibular apparatus.

Vestibular system. The system comprised of the otolith organs and the semi-circular canals that mediates the perception of head position and motion. (CRef. 3.210)

Vestibulo-ocular reflex. Reflexive eye movements initiated by stimulation of the vestibular system during head movements, in order to stabilize the eyes with respect to the object being viewed so that the image of the object on the retina will be stationary and not blurred by motion.

Visual acuity. The ability of an observer to resolve fine pattern detail. Acuity is usually specified in terms of **decimal acuity**, defined as the reciprocal of the smallest resolvable pattern detail in minutes of arc of visual angle. "Normal" or average acuity is considered to be 1.0 (a resolution of 1 min arc), although many young adults have a decimal acuity slightly better than this. (CRef. 1.602) (See also **Resolution threshold**; **Snellen acuity**.)

Visual angle. The angle subtended at the eye by the linear extent of an object in the visual field. It determines linear retinal image size. (CRef. 1.240)

Vitreous humor. The transparent, jelly-like substance that fills the back chamber of the eye (the space between the crystalline lens and the retina). (CRef. 1.201)

Weber ratio. See **Weber's law**.

Weber's law. A law which holds that the smallest detectable change in the magnitude of a stimulus along some dimension is always a constant proportion of the stimulus magnitude from which the difference is noted. The law is expressed mathematically as $\Delta I/I = k$, where I is the magnitude of the stimulus, ΔI is the smallest detectable change in magnitude, and k is a constant that is often called the **Weber fraction** or **Weber ratio**.

White noise. Random noise whose noise spectral level (noise-power density) is uniform over a wide frequency range; termed "white noise" by analogy to white light.

Section 1.1 Measurement of Light

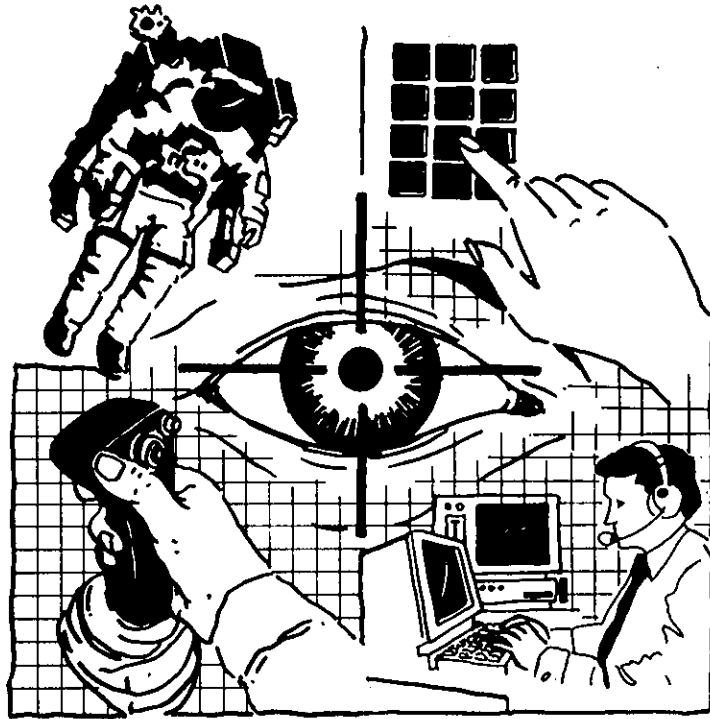

1.101 Range of Visible Energy in the Electromagnetic Radiation Spectrum

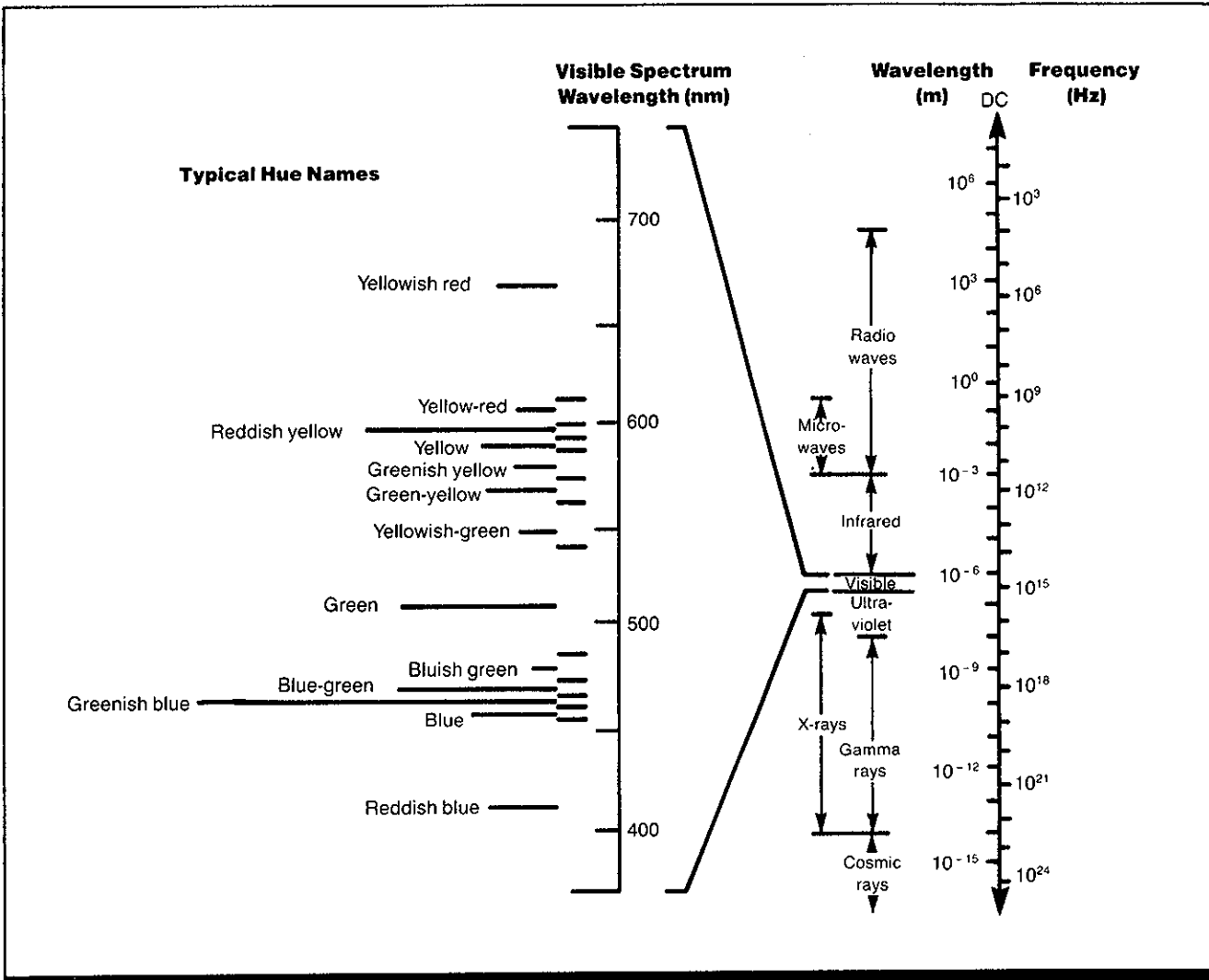

Figure 1. The position of the visible spectrum within the electromagnetic spectrum. The visible spectrum is expanded to show the colors associated with various wavelengths. Note that visible light is plotted on a linear scale, while the larger portion of the spectrum is plotted on a log scale. (From R. W. Burnham, R. M. Hanes, & C. J. Bartleson, *Color: A basic guide to basic facts and concepts*. Copyright © 1963 by John Wiley & Sons, Inc. Reprinted with permission.)

Key Terms

Visible spectrum; wavelength

General Description

The electromagnetic radiation spectrum ranges from wavelengths of 10-15 meters (cosmic rays) to wavelengths of many kilometers (radio waves). Only a very small portion of the total range is seen by humans as visible light. The eye is sensitive to wavelengths from ~400 to ~700 nm (1 nm = 10^{-9} m). (Wavelength limits are difficult to specify pre-

cisely; the visible spectrum is longer with high intensities of light.)

The lens of the eye absorbs wavelengths below ~400 nm, making the visual system insensitive to such radiation (and lessening the effect of ultraviolet radiation on the retina). Because radiative energy per quantum of light is inversely proportional to wavelength, wavelengths >700 nm,

although impinging upon the retina/are not energetic enough to produce a chemical reaction in the photoreceptors. Thus, humans feel infrared radiation as heat but do not see these or longer wavelengths.

Visible lights of various wavelengths are perceived as different colors. Wavelengths at ~470 nm are seen as blue,

~535 nm as green, and ~650 nm as red. During daylight viewing, the eye is maximally sensitive to wavelengths of about 550 nm (yellowish-green). White light is a mixture of all wavelengths. Passing white light through a prism will separate the wavelengths. Humans can discriminate ~150-200 variations of hue in the visible spectrum.

Constraints

- The perceived color of light depends not simply upon wavelength, but also upon intensity, the part of the eye to which light is delivered, ambient illumination, size of stimulus, and duration of stimulus presentation (CRefs. 1.704, 1.705).

Key References

- | | | |
|---|--|--|
| 1. Coren, S., Porac, C., & Ward, L. M. (1984). <i>Sensation and perception</i> . Orlando, FL: Academic Press. | 2. Farrell, R. J., & Booth, J.M. (1984). <i>Design handbook for imagery interpretation equipment</i> . Seattle, WA: Boeing Aerospace Co. | 3. Haber, R. N., & Hershenson, M. (1973). <i>The psychology of visual perception</i> . New York: Holt, Rinehart & Winston. |
|---|--|--|

Cross References

- | | |
|---|---|
| 1.102 Spectral distribution of radiant energy; | 1.110 Luminous efficiency (spectral sensitivity); |
| 1.103 Range of light intensities confronting the eye; | 1.704 Chromaticity discrimination; |
| | 1.705 Factors affecting color discrimination and color matching |

1.102 Spectral Distribution of Radiant Energy

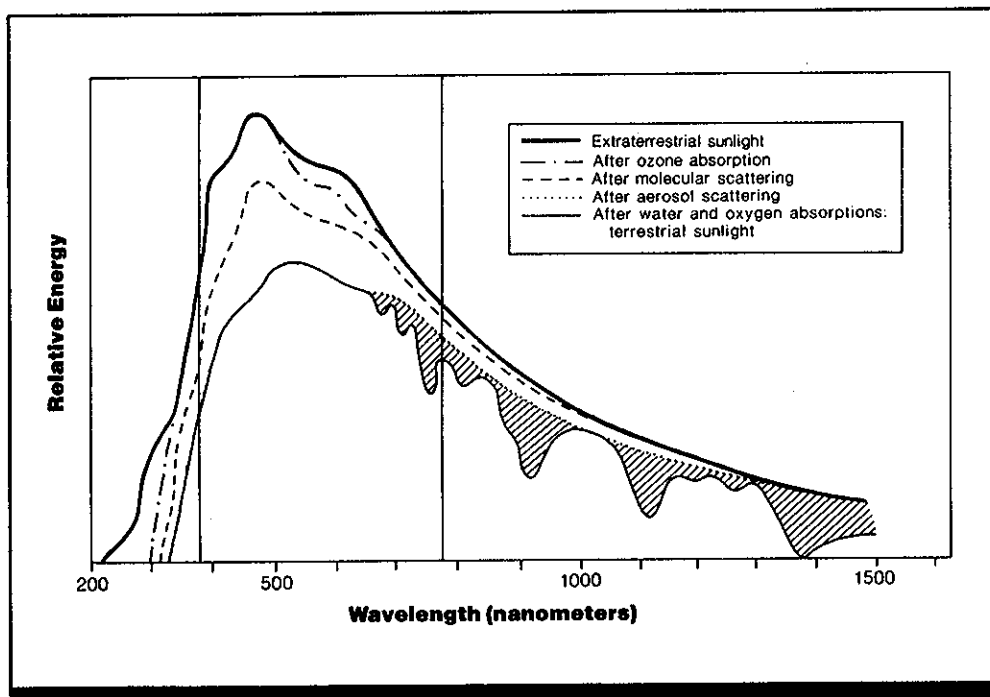

Figure 1. The spectral distribution of sunlight as it approaches the earth's surface. As the light passes through the different strata of the atmosphere, the spectral content changes. The vertical lines indicate the region of greatest sensitivity of the visual system, which is near the peak wavelength of sunlight. The most dominant spectral components of sunlight at the earth's surface fall between the regions of greatest visual sensitivity for foveal and peripheral vision. (From Ref. 2)

Key Terms

Color temperature; colorimetry; light sensitivity; photometry; spectral distribution; visual pathology; wavelength

General Description

A light source, natural or artificial, emits radiation at a single wavelength (line spectrum), across a narrow set of wavelengths, or across a wide wavelength band. Light emitting diodes generate narrow wavelengths of light; emissions from gas discharge lamps and lasers are line spectra. The spectral emission of any radiation source can be measured by a spectroradiometer. Figure 1 illustrates the spectral distribution of sunlight as it advances toward the earth's surface. Figure 2 shows the spectral emissions of three common artificial sources of illumination.

Another means of characterizing the nature of an incandescent light is through its color temperature (CRef. 1.107). The spectra of such sources vary with their temperatures. At low temperatures, the rate of radiation is low and most of it is concentrated at long wavelengths; as temperature increases the rate of radiation becomes higher and the bandwidth broader, with more light emitted at shorter wavelengths.

The human eye responds to light in the electromagnetic spectrum in the range of approximately 360-830 nm. Greatest sensitivity for foveal (cone) vision occurs at about

555 nm and for peripheral (rod) vision at about 505 nm. The limiting factor in an observer's perception of short wavelength light is the absorption of such light by the ocular media and the lens of the eye (CRef. 1.202). The eye's sensitivity to light of different wavelengths is characterized by **luminous efficiency functions** (CRef. 1.110), which show the relative effectiveness of light of a given wavelength in stimulating vision. Most observers (i.e., those with normal color vision) will, over a wide range of viewing conditions, require no more than three fixed primary spectral lights added together to match any other color mixture (CRef. 1.702). Color matches vary across individuals with the age of the observer; differences between individuals are also caused by color anomalies that are either acquired or congenital (CRef. 1.726).

Acquired anomalies of color vision may be associated with prolonged or intense exposure to radiation in or near the visible spectrum. Specifically, the cornea and conjunctiva of the eyes (CRef. 1.201) tend to absorb ultraviolet radiation below about 295 nm. Excessive exposure to ultraviolet radiation can induce pathological processes in these two structures. The lens absorbs radiation in the range

of about 295-380 nm; the formation of cataracts can result from such radiation exposure. The conjunctiva, cornea, and lens seem to protect the vitreous humor from damage (shrinkage of the vitreous gel and other types of photodegradation) from ultraviolet light. Pathological changes in the retina of the eye appear sometimes to be caused by extended exposure to short wavelength light from the sun. Retinal lesions are unlikely to result from exposure to longer wavelength light, unless one were to stare at the sun for at least ~15 min with a very large (8 mm) pupil. In fact, if wavelengths below 700 nm in solar radiation are removed by a filter, one can gaze at sunlight for considerable periods of time (Ref. 1).

Another increasingly common source of radiation exposure is the laser, which can induce considerable damage at the level of the retina. Laser wavelengths below 500 nm tend to damage the inner layers of the retina; those at about 500 nm affect the pigment epithelium. Such damage can occur even at such an apparently low power output as 10 w/m² due to the focusing of the light and ocular processes.

Finally, some research has indicated that, at least for the amphibian eye, prolonged periods of darkness will induce retinal damage (Ref. 3).

Applications

The various artificial and natural light sources used as illuminants for displays and for visual scenes will affect an observer's perceptions differently; in some cases, the observer will ignore differences in illumination (i.e., discount the illuminant).

Key References

1. Ham, W. T., Jr., Mueller, H. A., Ruffolo, J. J., Jr., & DuPont, G., III. (1980). Solar retinopathy as a function of wavelength: Its significance for protective eyewear. In T. P. Williams & B. N. Baker (Eds.), *The effects of constant light on visual processes*. New York: Plenum.
2. Henderson, S. T. (1977). *Daylight and its spectrum* (2nd Ed.). New York: Wiley.
3. Hollyfield, J. G., Rayborn, M. E., & Medford, D. (1980). Damaging effects of constant light and darkness on the retina of the frog. In T. P. Williams & B. N. Baker (Eds.), *The effects of constant light on visual processes*. New York: Plenum.
4. Lerman, S. (1980). *Radiant energy and the eye*. New York: MacMillan.
5. Wyszecki, G., & Stiles, W. S. (1967). *Color science: Concepts and methods, quantitative data and formulae*. New York: Wiley.

Cross References

- 1.107 Color temperature;
- 1.110 Luminous efficiency (spectral sensitivity);
- 1.201 Anatomy of the human eye;
- 1.202 Transmissivity of the ocular media;
- 1.303 Equal-brightness and equal-luminance contours for targets of different colors (spectral content);
- 1.304 Equal-brightness contours for lights of different colors (wavelength) at different levels of adapting luminance;
- 1.702 Color mixture and color matching;
- 1.704 Chromaticity discrimination;
- 1.705 Factors affecting color discrimination and color matching;
- 1.726 Congenital color defects

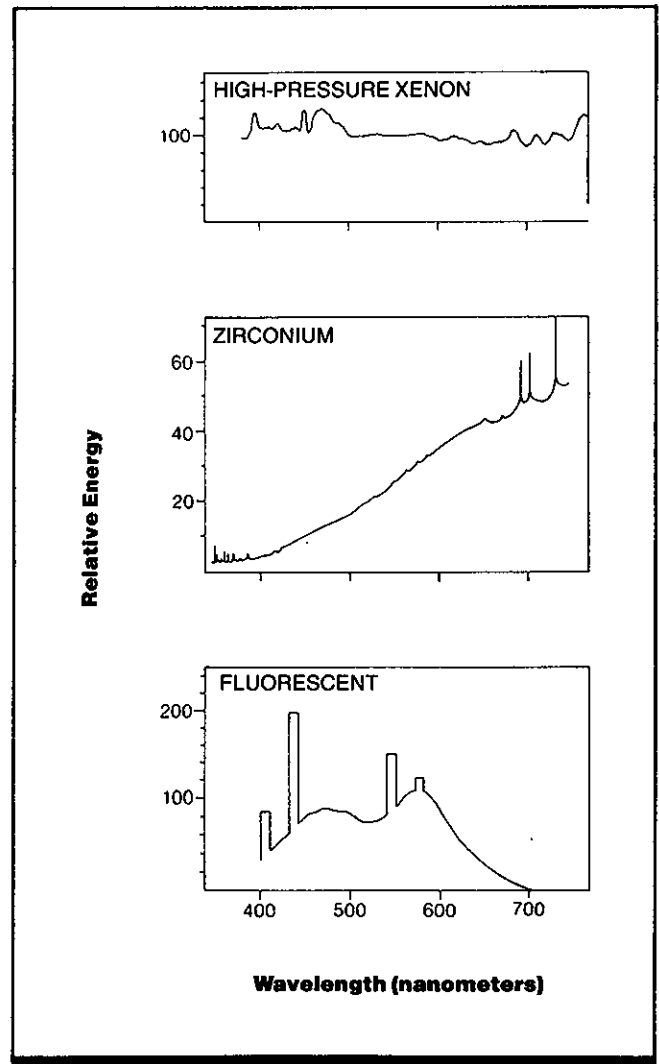

Figure 2. The spectral energy output from three commonly used artificial sources of illumination. The high-pressure xenon lamp (a) produces a relatively even distribution across the range of greatest visual sensitivity, while the zirconium lamp (b) is weighted at long wavelengths. Conventional fluorescent lamps (c) have narrow band spectra superimposed on a broadband spectrum. (From G. Wyszecki & W. S. Stiles, *Color science: Concepts and methods, quantitative data and formulae*. Copyright © 1967 by John Wiley & Sons. Reprinted by permission.

1.103 Range of Light Intensities Confronting the Eye

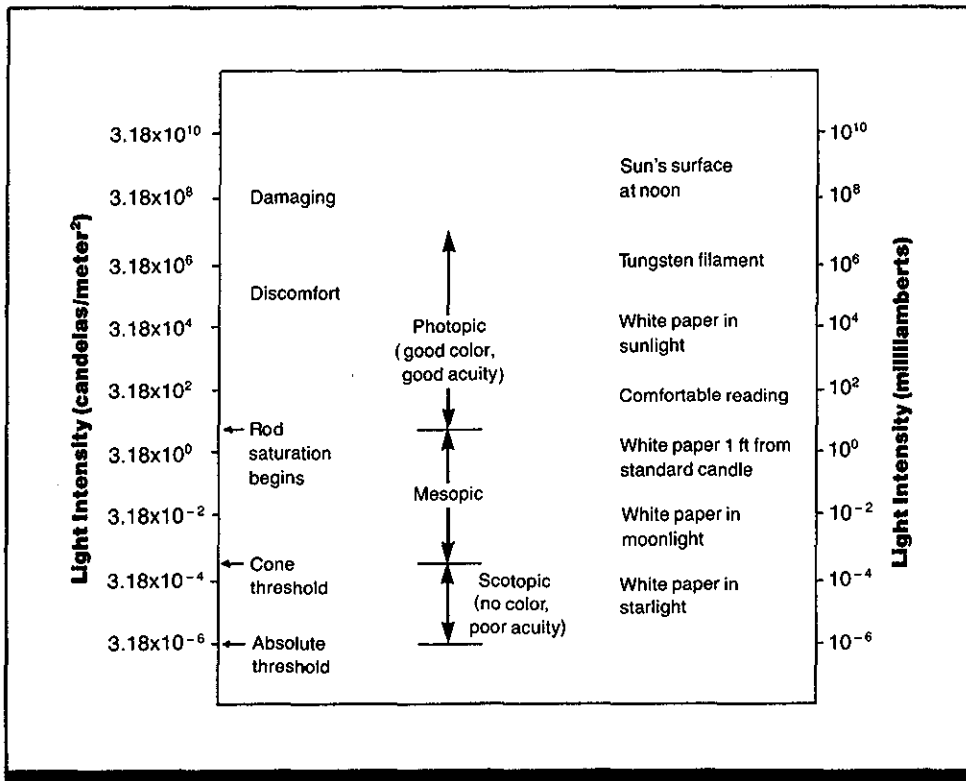

Figure 1. The range of light intensities that confront the human eye. (Adapted from C. H. Graham [Ed.], *Vision and visual perception*. Copyright © 1965 by John Wiley & Sons, Inc. Reprinted with permission.)

Key Terms

Illumination level; luminance; mesopic vision; photopic vision; scotopic vision

General Description

The human eye is sensitive to a wide range of light intensities, from a minimum visible level of $\sim 0.000003 \text{ cd/m}^2$ to an upper tolerance limit of over $300,000 \text{ cd/m}^2$. Vision at very low levels of illumination (e.g., starlight) is termed **scotopic** vision and is mediated by the **rods**; visual acuity is poor with scotopic vision and no sensation of color (hue) occurs. Vision at high intensity levels (e.g., daylight) is known as **photopic** vision and is mediated by the **cones**; photopic vision is characterized by high visual acuity and

the perception of color. **Mesopic** (mixed) vision (mediated by both rods and cones) occurs with intermediate light intensities (e.g., moonlight).

Figure 2 shows how outdoor brightness decreases during twilight. **Dark adaptation** of the eye with declining illumination is at least as rapid as this normal decline in ambient illumination at evening. Figure 3 shows how the luminance of a test patch changes with the angular elevation of the sun above the horizon.

Constraints

- Sensitivity to light depends on the eye's state of **adaptation**. Maximum scotopic sensitivity requires ~ 1 hr of dark adaptation even after as little as a few minutes' exposure to photopic light levels. The time course of **light adaptation** is similar for rods and cones and is much faster than dark adaptation, requiring only a few minutes' exposure at a high luminance level.

Key References

1. Beebe-Center, J. G., Carmichael, L., & Mead, L. C. (1944). Daylight training of pilots for night flying. *Aeronautical Engineering Review*, 3, 9-29.
2. Graham, C. H. (Ed.) (1965). *Vision and visual perception*. New York: Wiley.

Cross References

- 1.101 Range of visible energy in the electromagnetic radiation spectrum

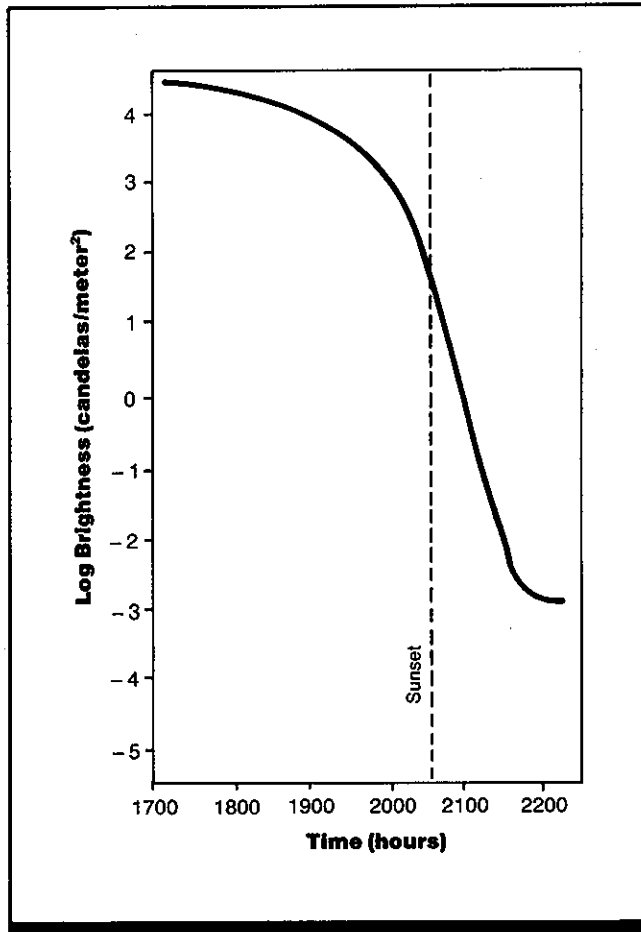

Figure 2. The decrease in brightness from daylight (5:00 pm) to darkness (sunset ~9:30 pm) on July 14, 1942 (adapted from Ref. 2). Angle of test patch in relation to sun not given.

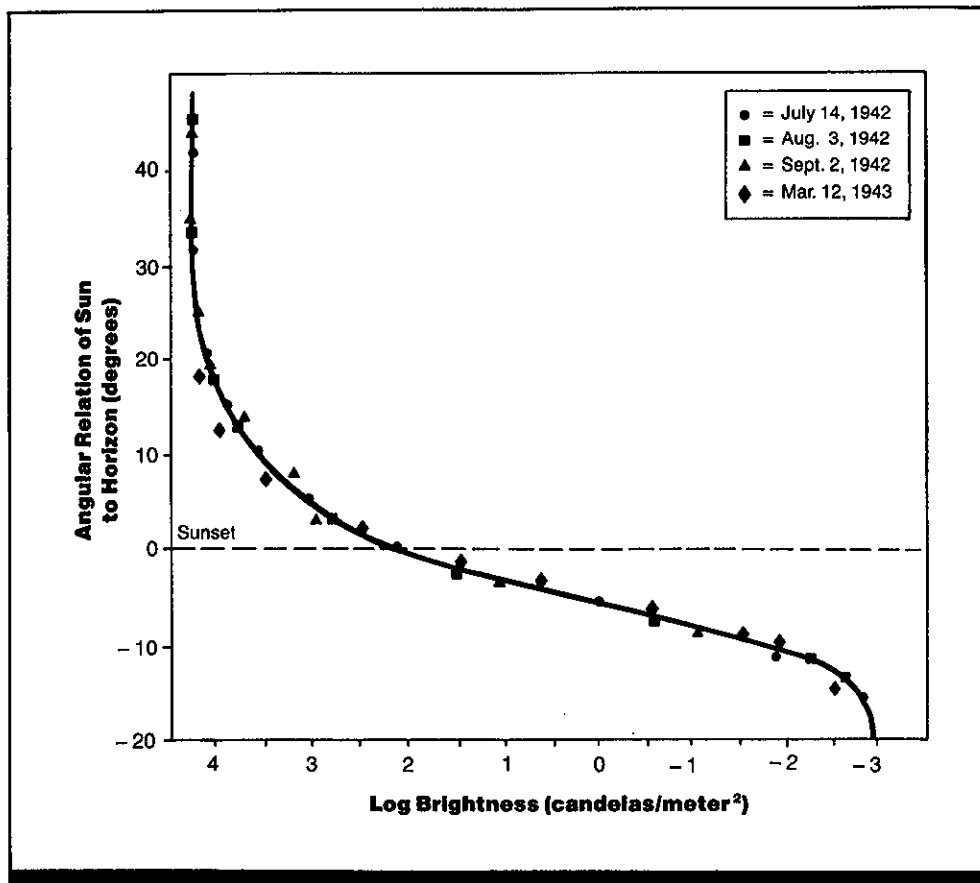

Figure 3. The relationship between the brightness of a stimulus patch in a constant position and the angular elevation of the sun relative to the horizon on four days during different seasons of the year. (From Ref. 1)

1.104 Measurement of Radiant and Luminous Energy

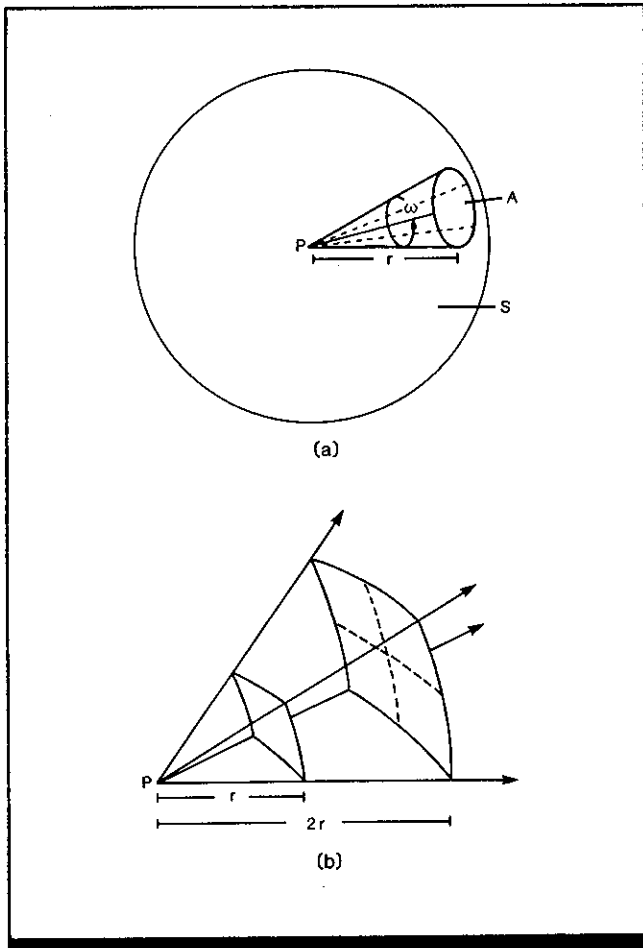

Figure 1. Representation of solid angle ω and the inverse-square law. (a) Point P lies at the center of sphere S with radius r . A set of lines of radius r emanating from P defines an area A on the surface of S . The steradian measure of solid angle ω is the ratio $\omega A/r^2$. (b) The radiant flux emitted by point source P irradiates a larger area as the distance r from the source increases. The irradiance varies inversely with the square of the distance r . Thus at distance $2r$ the irradiance is $1/4$ that at distance r . (From Ref. 1)

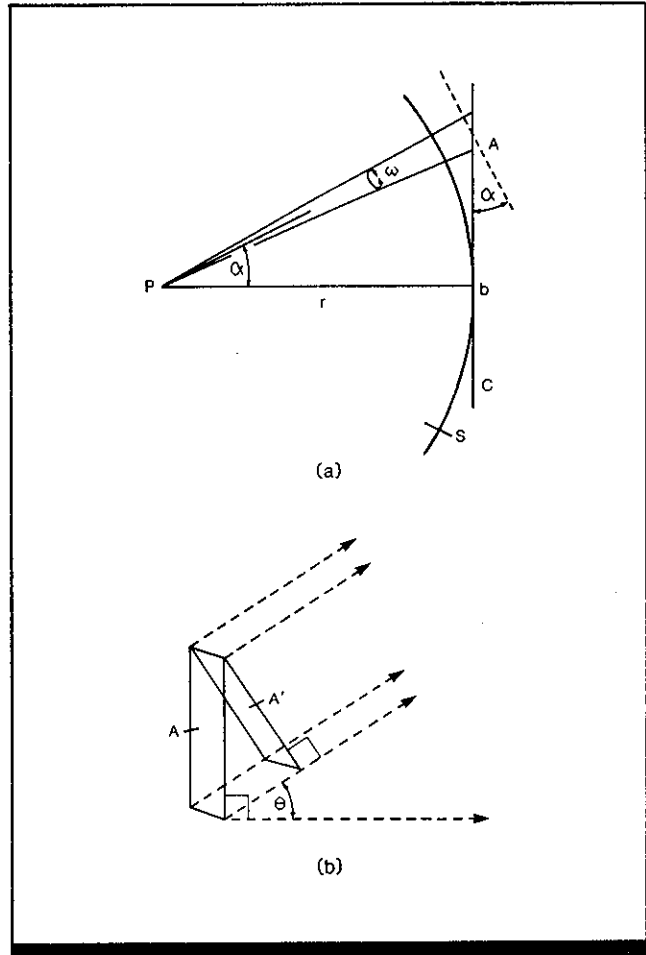

Figure 2. Definition of irradiance and radiance at an angle. (a) The irradiated surface C is a flat screen tangent to sphere S only at point b . As α , the angle from the normal to C , increases, the distance from source P to the surface of C increases by the factor $1/\cos \alpha$. In addition, since the irradiating beam striking C deviates from the perpendicular by angle α , the radiant flux contained in a narrow solid angle incident perpendicularly on surface A will cover a larger area on surface C (by a factor of $1/\cos \alpha$). (b) The horizontal dashed line shows the perpendicular measurement of the radiance of surface element A of an extended source. If the direction of measurement varies from the perpendicular by angle θ , only the projected area A' is sampled, and the area of A' is less than that of A by a factor of $\cos \theta$. (From Ref. 1)

Key Terms

Illumination level; inverse square law; irradiance; luminance; luminosity; luminous efficiency; luminous flux; photometric units; radiance; radiant flux; radiometric units

Table 1. Measures of radiant energy.

Measure	Formula	Units
Radiant Intensity (I_e)	$I_e = P_e/\omega$, where P_e = radiant flux or energy in watts (joules/sec); $\omega = 4\pi$ steradians (sr)	watts/sr
Irradiance (E_e)	$E_e = I_e/r^2$ (spherical surface) $E_e = I_e \cos^3 \alpha/r^2$ (surface at angle α), where I_e = radiant intensity; r = distance from source; α = angle of incidence (see Fig. 2a)	watts/m ²
Radiance	$L_e = I_e/A$ (normal surface) $L_e = I_e/A \cos \theta$ (inclined surface) where I_e = radiant intensity; A = area of source's surface element; θ = angle of incidence (see Fig. 2b)	watts/sr/m ²

General Description

Measurement of Radiant Energy

There are three fundamental types of radiant energy measurement: the total energy emitted from a point in a given direction (radiant intensity), the energy incident on a surface at some distance from a source (irradiance), and the energy emitted from a unit area of a surface (radiance).

Radiant Intensity. When electric power is supplied to a lamp, radiation is emitted. The radiant energy P_e , emitted per unit of time, is measured in watts. A set of lines radiating from a point defines a solid angle at that point (Fig. 1). The radiant intensity I_e of a point source with radiant flux P_e is the radiant flux per solid angle ω ,

$$I_e = P_e/\omega, \quad (1)$$

expressed in units of W/sr (see Table 1). Artificial sources typically do not radiate uniformly in all directions. In this case radiant energy intensity is specified with respect to specific direction.

Irradiance. When radiant flux is incident on a surface, the surface is said to be irradiated. Let P_e be that radiant flux incident on the interior surface of a sphere of radius r . The irradiance E_e is the radiant flux from a point source falling on a unit area of this surface,

$$E_e = \frac{P_e}{\omega r^2}, \quad (2)$$

expressed in W/m².

The irradiance E_e is usually expressed in terms of the radiant intensity I_e by substituting the terms $P_e = \omega I_e$ into Eq. 2. Irradiance is related to radiant intensity I_e by the expression

$$E_e = \frac{I_e}{r^2}. \quad (3)$$

The radiant flux emitted by a point source falls on a successively greater area as the distance from the source increases (Fig. 1b). As noted in Eq. 3, the irradiance E_e varies inversely with the square of the distance r from the source P_e . This relation is called the *inverse square law*.

Suppose the surface is a flat screen, rather than a spherical surface (Fig. 2a). Two important changes occur as α , the angle from the normal, increases. First, the distance to the surface C is greater than r by the factor $1/\cos \alpha$, and in accord with the inverse square law, the irradiance will be re-

duced by a factor of $\cos^2 \alpha$. Second, since the area of the surface is irradiated at angle α , rather than perpendicularly, the radiant flux contained in a narrow solid angle ω will be spread over a larger area. The total irradiance on C at angle α is given by

$$E_e = I_e \cos^3 \frac{\alpha}{r^2} \quad (4)$$

Thus on a flat surface, irradiance from a point source decreases with the \cos^3 of the angle from the normal.

The definition of irradiance and the operation of the inverse square law are valid only for a point source of light. Few physical light sources approximate a point source. Examples of natural point sources are stars. For practical purposes of measurement, the inverse square law will operate with an error less than 1% provided the maximal dimension of the source is smaller than or equal to 1/10 the distance at which irradiance is measured.

Radiance. The majority of light sources do have finite dimensions and are called *extended sources*. Radiance L_e is used to describe the radiant flux per unit of solid angle of an extended source measured in a given direction per unit area of the source when projected in that direction. Radiance refers to the areal density of radiant intensity either leaving a source or arriving at the surface of an object. In the measurement of radiance (Fig. 2b) of an extended source in a direction normal to the surface, L_e is given by I_e/A where A is the area of an infinitesimal surface element of the source. With measurement at angle θ to the normal, only the projected surface, A' is given by $A \cos \theta$. Radiance is expressed as

$$L_e = \frac{I_e}{A} \cos \theta = \frac{P_e}{\omega A} \cos \theta \quad (5)$$

in W/sr/m², where A is the area of the surface of the source and θ is the angle between the normal from the surface and the direction of measurement.

Photometric Units

Radiometric units have a purely physical specification. However, the definition of light includes reference to the human observer. *Luminous flux* is the radiant flux weighted by the spectral luminous efficiency function of the eye (CRef. 1.110). This function describes the relative sensitivity of the eye to different wavelengths. Standard luminous efficiency functions are defined for both **photopic** (bright,

Table 2. Measures of luminous energy (and related radiant energy measures).

Luminous Energy Measures	Units	Related Radiant Energy Measurement
Luminous Intensity (I_v)	candela (cd) [lumen/sr]	Radiant Intensity
Illuminance (E_v)	lux [lumen/m ²]	Irradiance
Luminance (F_v)	candela/m ² [lumen/m ² /sr]	Radiance

light-adapted, or cone-dominated) and scotopic (dim, dark-adapted, or rod-dominated) adaptation levels.

Sets of units parallel to those for radiant energy are used to specify luminous energy and are called *photometric units*. Photometric energy is radiant energy modified by the luminous efficiency function of the standard observer. Corresponding to the quantities of radiant intensity, irradiance and radiance are the photometric quantities *luminous intensity*, *illuminance*, and *luminance* (Table 2). Luminous energy F_v (lumen) is related to radiant energy P_e by two equations:

$$F_v = K_m \int P_e(\lambda) V(\lambda) d\lambda, \quad (6)$$

$$F_v' = K'_m \int P_e(\lambda) V'(\lambda) d\lambda, \quad (7)$$

where $V(\lambda)$ and $V'(\lambda)$ are standard luminous efficiency functions for photopic and scotopic conditions, respectively, defined by the Commission Internationale de l'Eclairage; K_m and K'_m are constants that relate (photopic and scotopic) lumens to watts. Equation 5 is applicable for photopic conditions of vision, Eq. 6 for scotopic levels of vision.

The unit of luminous intensity I_v (lumens/sr) is called the candela (cd); that of illuminance E_v (lm/m²) is called the lux; and that of luminance L_v (lm/m²/sr) is called the candela per square meter (cd/m²). Table 2 summarizes the relations between the radiometric and photometric quantities.

—Adapted from Ref. 2

Constraints

The amount of radiant energy perceived by an observer will depend not only on the absolute amount of energy in a signal, but also on the observer's relative spectral sensitivity and location in relation to the light source.

Key References

<p>1. Pokorny, J., Smith, V. C., Verriest, G., & Pinckers, A. J. L. G. (1979). <i>Congenital and acquired color defects</i>. New York: Grune & Stratton.</p>	<p>2. Pokorny, J., & Smith, V. C. (1986). Colorimetry and color discrimination. In K. Boff, L. Kaufman, & J. P. Thomas (Eds.), <i>Handbook of perception and human performance: Vol. 1. Sensory processes and perception</i>. New York: Wiley.</p>	<p>3. Teele, R. P. (1965). Photometry. In R. Kingslake (Ed.), <i>Applied optics and optical engineering</i> (Vol. 1). New York: Academic Press.</p>
--	--	---

Cross References

I.110 Luminous efficiency (spectral sensitivity)

Notes

✓

✓

✓

✓

1.105 Image Luminance with Optical Viewers

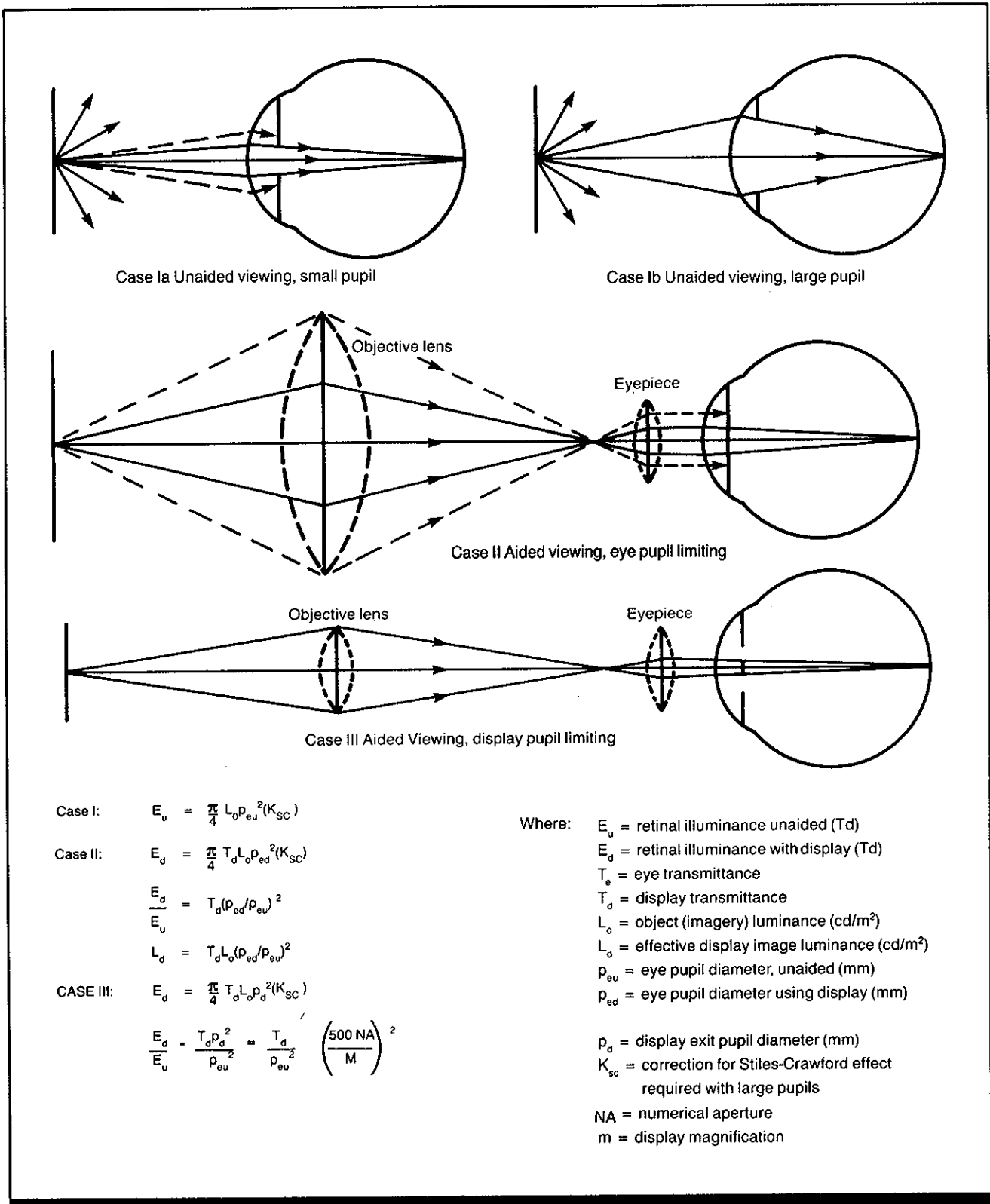

Figure 1. Viewing geometry and equations for determining display image luminance. (From Ref. 1)

Key Terms

Binoculars; display brightness; exit pupil; eyepiece; microscope; objective; ocular; retinal illuminance; telescope

General Description

A microscope, a telescope, or one side of a pair of binoculars consists of two basic parts: an objective lens (or objective) that forms a primary image of an object or scene, and an eyepiece (or ocular) that magnifies the primary image and forms a virtual image that the eye focuses upon the retina. A lens system or prism assembly may be inserted between the objective and the eyepiece to yield an upright, unreversed (erected) image or an image that is changed in magnification or is more conveniently located. The transmittance and magnification of erecting lenses must be considered in image luminance calculations, as must the transmittance of any prisms and the reflectivity of any mirrors used.

For a round objective, the image of the objective lens formed by the eyepiece is a circular disc of light, known as the Ramsden Disc or exit pupil of the instrument. The exit pupil contains all the light collected by the objective that is within the field of view of the eyepiece minus a small amount due to absorption and that part of surface reflections and scattering that is lost. When the observer's eye is properly positioned with respect to the instrument, the eye entrance pupil (the image of the real pupil formed by refraction at the cornea) and the instrument exit pupil coincide in position. When the eye entrance pupil is as large or larger than the instrument exit pupil, the eye receives all the light in the exit pupil minus a miniscule amount reflected by the cornea. In this case, except for the small light losses mentioned, retinal illuminance is almost the same with or without the instrument: the instrument view and the direct view appear equally bright. However, if the exit pupil is smaller than the eye pupil, the instrument view will appear dimmer than the direct view: the display luminance is *exit-pupil limited* and the retinal illuminance is less. When the exit pupil is larger than the eye pupil, only light from a cen-

tral disc of the objective lens can get into the eye: the viewing is *eye-pupil limited*. However, direct and instrument views appear equally bright in this case, except for loss due to transmittance of the optics.

Figure 1 shows the optical situation for unaided and aided viewing and gives equations for calculating display image luminance. The rays traced are for a point on the optical axis of the instrument, and calculations are for on-axis luminance. Case I is for unaided (no instrument) viewing. Equations defining retinal illuminance, E , must be corrected for eye transmittance, T_e , unless E is in units (e.g., trolands) that include T_e . If, as in Case II, the exit pupil is larger than the eye pupil and/or if instrument transmittance is quite low, the eye pupil may open to a larger diameter with instrument viewing than when the display is viewed directly (no instrument). In this case, the light reaching the retina is increased by the ratio of the two pupil areas, P_{ed}^2/P_{eu}^2 . In Case III, where the eye pupil is larger than the exit pupil, the amount of light reaching the retina is determined in terms of retinal illuminance; then this quantity is used to find the luminance that would produce the same retinal illuminance when the eye pupil is the limiting aperture. Note that in Case III, retinal illuminance is reduced by both display (or instrument) transmittance, I_d , and by an exit pupil smaller than the eye pupil. In this case, display pupil diameter, P_d , can be replaced by $500 \times (\text{numerical aperture})/(\text{display magnification})$. When numerical aperture (NA) is not changed with increased magnification, image luminance decreases by the square of magnification. Numerical aperture is $NA = N \sin \theta_o$, where N is the index of refraction of the medium between the objective and the object, and θ_o is the angular aperture (i.e., the angle of obliquity of the marginal rays collected by the objective). For air, the index of refraction is essentially unity.

Key References

1. Farrell, R. J., & Booth, J. M. (1984). *Design handbook for imagery interpretation equipment*. Seattle, WA: Boeing Aerospace Co.

Cross References

- 1.104 Measurement of radiant and luminous energy;
- 1.106 Conversion of scene luminance to retinal illuminance

1.106 Conversion of Scene Luminance to Retinal Illuminance

Key Terms

Effectivity ratio; pupil size; retinal illuminance; Stiles-Crawford effect; troland

General Description

Retinal illuminance is the product of scene luminance and effective eye pupil area. Larger pupils admit more light. When scene luminance is very low, pupil diameter may be as large as 7 mm, while at very high luminances it may be as small as 2 mm. A summary curve of pupil diameter, plotted against scene luminance, is shown in Fig. 1. (This curve is the average for the six studies described in CRef. 1.233.)

Effective pupil area for estimating retinal illuminance is less than actual pupil area because the relative contribution of light to the sensation of brightness decreases as the light enters the pupil an increasing distance from the pupil center. This is termed the *Stiles-Crawford effect* (CRef. 1.111). It is a phenomenon of *cone* (or *photopic*) vision (daylight illumination levels) and does not occur for *rod* (or *scotopic*) vision (nighttime illumination). It is thought to be due to cone geometry. The ratio between effective and actual pupil area is called the *effectivity ratio*, a quantity that varies with pupil diameter and takes into account the Stiles-Crawford effect. The effective pupil area is thus the actual pupil area times this ratio (R), expressed as Eq. 1:

$$R = 1 - 0.0106d^2 + 0.0000416d^4 \quad (1)$$

where d is pupil diameter in mm. For example, for $d = 6$ mm, $R = 0.67$. Estimated retinal illuminance, I , taking R into account, is

$$I(\text{trolands}) = R \times \text{pupil area (mm}^2) \times \text{luminance (cd/m}^2) \quad (2)$$

Three common units of scene luminance are footlamberts

Applications

The scene luminance-retinal illuminance data are useful in comparing results of different researchers and in the design of optical instruments and eye protection devices.

Constraints

• Appreciably different pupil diameters at the same scene luminance are reported in the literature. Pupil size also varies considerably from one person to the next at the same scene luminance.

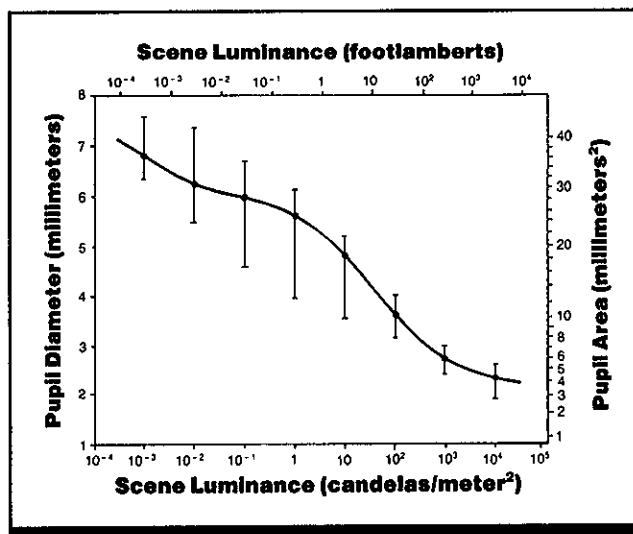

Figure 1. Eye pupil size as a function of scene luminance. Curve shown here is the mean curve from Entry 1.233, Fig. 1. Points on the curve represent the weighted averages from six studies and 125 subjects. The bars show the range of averages from the six studies. (From Ref. 2)

(fL), millilamberts (mL), and candelas/meter² (cd/m²). Units can be converted by equation: 1 cd/m² = 0.292 fL = 0.314 mL, or by graphs, such as those of Figs. 2 and 3, which are for scenes viewed with a natural pupil. By comparing the two curves on each graph, one based on actual pupil size and one with pupil size corrected for the Stiles-Crawford effect, the magnitude of the effect over a range of scene luminances is apparent. A nomogram such as that of Fig. 4, which has scales for three common luminance units, can also be used to convert units.

- Pupil size is affected by a number of factors, such as target distance, time since change in scene luminance, and whether one or both eyes are open (CRefs. 1.232, 1.233, 1.234).
- Scene luminance to retinal illuminance conversions do not take into account differences in spectral transmissivity of the eyes.

Key References

1. Bartleson, C. J. (1943). Pupil diameters and retinal illuminances in interocular brightness matching. *Journal of the Optical Society of America*, 58, 853-855.

2. Farrell, R. J., & Booth, J. M. (1984, February). *Design Handbook for Imagery Interpretation Equipment*. Seattle, WA: Boeing Aerospace Co.
 3. Jacobs, D. H. (1944). The Stiles-Crawford effect and the de-

sign of telescopes. *Journal of the Optical Society of America*, 34, 694.

4. Reeves, P. (1918). Rate of pupillary dilation and contraction. *Psychology Review*, 25, 330-340.

Cross References

1.111 Luminous efficiency: effect of pupil entry angle;
 1.232 Monocular versus binocular pupil size;

1.233 Pupil size: effect of luminance level;
 1.234 Pupil size: effect of target distance

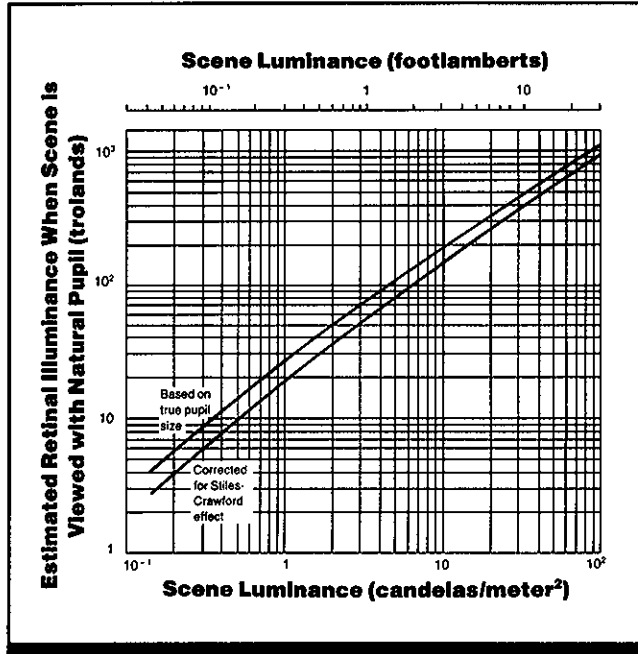

Figure 2. Conversion of scene luminance (10^{-1} - 10^2 cd/m²) to retinal illuminance. (From Ref. 2)

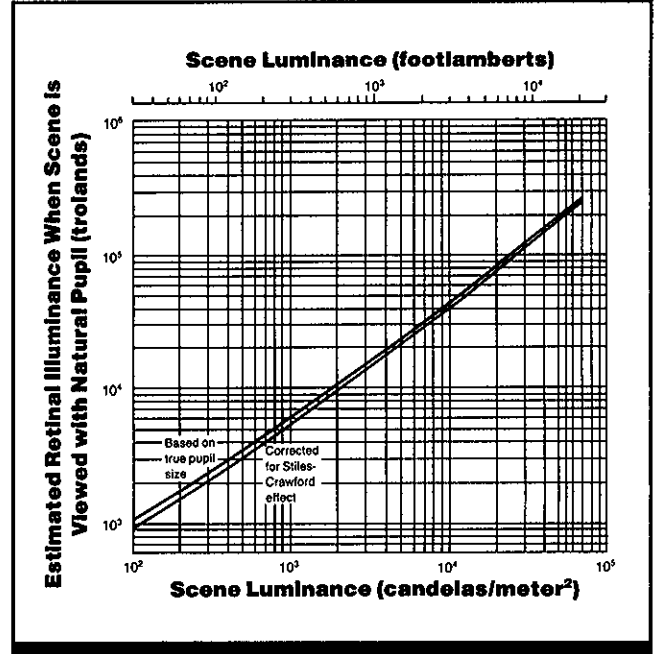

Figure 3. Conversion of scene luminance (10^2 - 10^5 cd/m²) to retinal illuminance. (From Ref. 2)

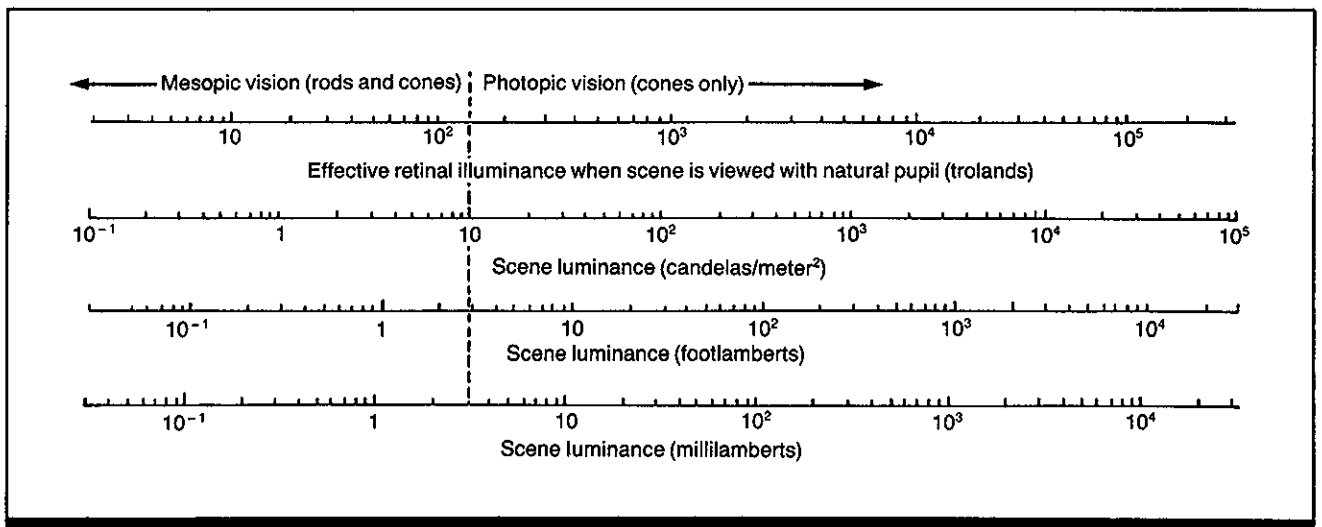

Figure 4. Conversion of three scene luminance units to effective retinal illumination. (From Ref. 3) The relationship among the three luminance units is: 1 cd/m² = 0.292 fL = 0.314 mL; 1 fL = 3.426 cd/m² = 1.076 mL; 1 mL = 0.929 fL = 3.183 cd/m². (From Ref. 2)

1.107 Color Temperature

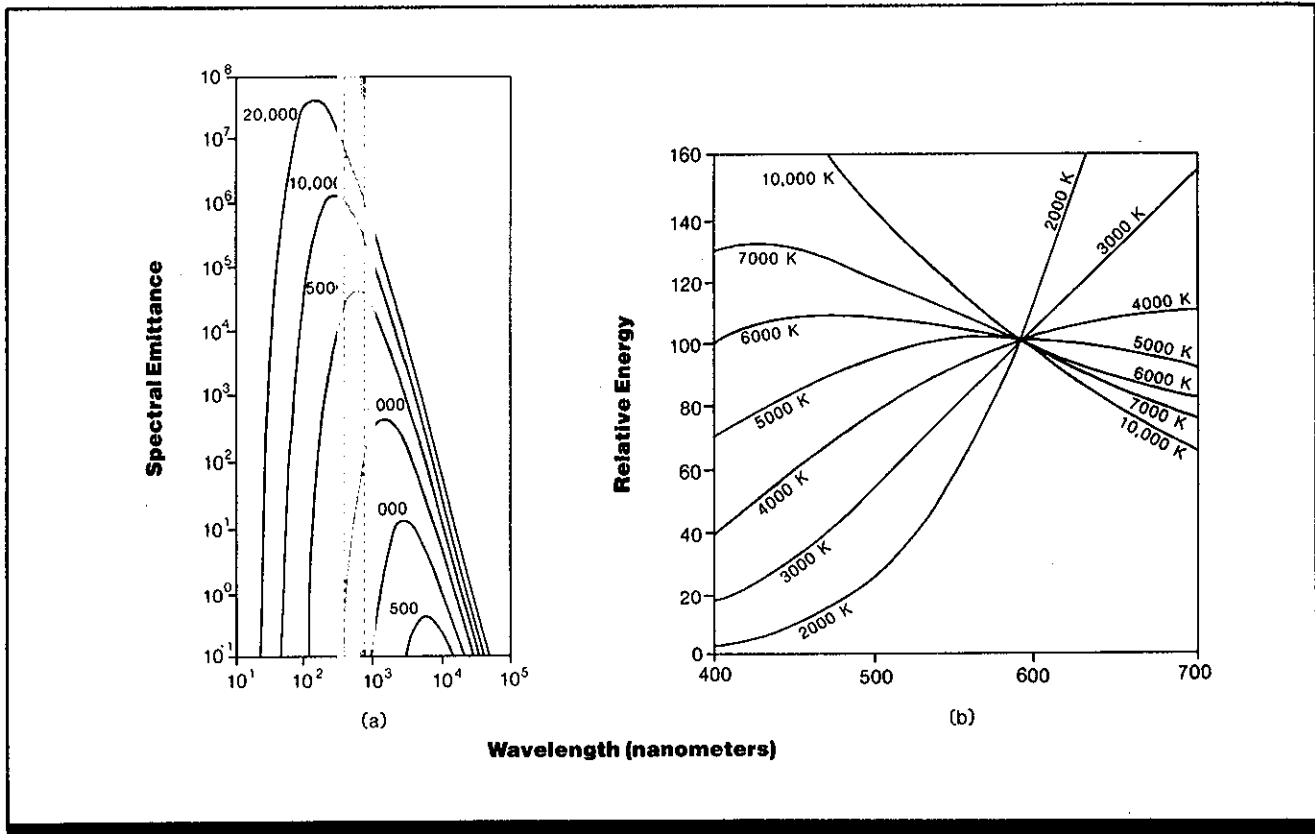

Figure 1. (a) Spectral emission of a blackbody radiator as a function of temperature and wavelength. The gray band indicates the visible spectrum. (b) Relative energy in the visible spectrum as a function of color temperature. The relative energy levels have been normalized so that the value for each temperature equals 100 at 590 nm. (From Ref. 4)

Key Terms

Blackbody radiator; chromaticity; color temperature; colorimetry; correlated color temperature; ideal radiator; reciprocal color temperature

General Description

Incandescent light sources are usually specified by their color temperature. Color temperature is based on the emission of an **ideal radiator** whose spectral output differs very little from that of the light source. The output of the ideal radiator is dependent on only one parameter, T , its temperature. Figure 1a illustrates the emittance of an ideal radiator by wavelength as a function of temperature. The relative output (J_λ) of the ideal radiator at a given wavelength (J_λ) can be calculated by Eq. 1:

$$J_\lambda = \{C_1/(\lambda/1000)^5\} \{1/[C_2/(\lambda)T - 1]\}, \quad (1)$$

where $C_1 = 36,970$, $C_2 = 17,320$, $\lambda =$ wavelength (in nm), and T is temperature (in Kelvins). Figure 1b shows the relative energy in the visible spectrum as a function of wavelength; in this graph, the output is normalized so that for each value of T , when $\lambda = 590$ nm, the relative energy equals 100.

It is useful to specify standard illuminants because, with

both natural and artificial light, there is considerable variation in the spectral emission of radiation. With sunlight, for example, depending on such factors as elevation of the sun and direction of incident light, the nature of the illumination varies considerably. Inconsistencies can be reduced by using idealized "northern" light with moderate overcast, although, for extended series of observations, unvarying artificial lights are preferred over natural (i.e., inconsistent) sources. In most studies, one can be confident of reproducible results when the type of illuminant is well specified. Working standards for "white lights" have been specified by the Commission Internationale de l'Eclairage (CIE) and are called standard illuminants. They provide standards for calibrating colored filters and papers as well as nonspectral references for colorimetry. The four CIE standard illuminants are illustrated in Fig. 2 (relative spectral radiant power distributions are tabulated in Table 2). Standard illuminant A represents light at 2856°K; Standard D_{65} involves one particular phase of natural sunlight with a correlated color

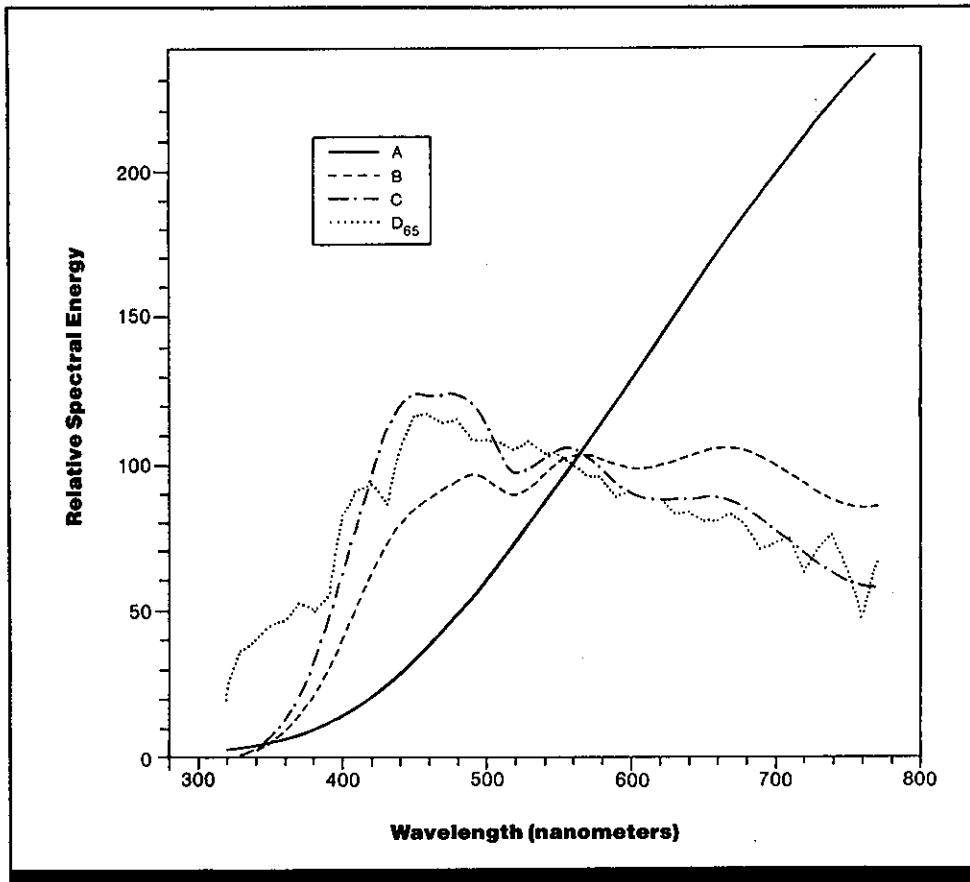

Figure 2. Spectral energy distribution of the four standard CIE illuminants A, B, C, and D_{65} . Illuminant A is that for an incandescent lamp light at color temperature of 2854°K; illuminants B, C, and D represent the correlated color temperatures of direct sunlight (4874°K), the light from an overcast sky (6774°K), and another phase of daylight (6504°K), respectively. (From *Handbook of perception and human performance*)

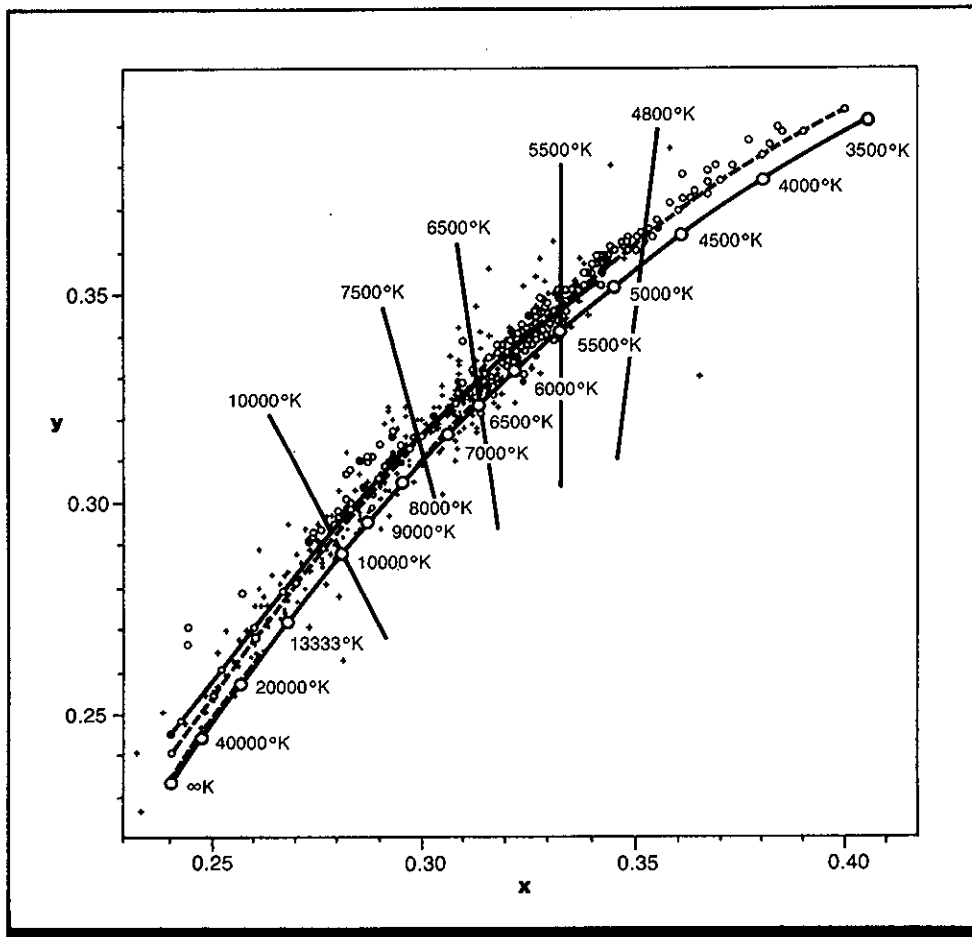

Figure 3. Part of the CIE 1931 (x,y) -chromaticity diagram showing chromaticity points of daylight as compared to chromaticity points implied by Planck's radiation law. The large open circles on the solid line depict the color temperature of a blackbody radiator. The straight lines intersecting the blackbody curve indicate isotherm lines for 4800°K, 5500°K, 6500°K, 7500°K, and 10000°K. Data points present observations from 622 measured relative spectral power distributions of daylight. Dashed curve is a plot of Eq. 2 representing a "daylight locus." (From G. Wyszecki & W. S. Stiles, *Color science: Concepts and methods, quantitative data and formulae* [2nd ed.]. Copyright 1982 by John Wiley & Sons, Inc. Reprinted with permission.)

1.1 Measurement of Light

temperature of $\sim 6504^\circ\text{K}$. Standard *B* represents sunlight with correlated color temperature of 4874°K , Standard *C* represents "average daylight" with correlated color temperature of 6774°K . An alternative specification of color temperature is reciprocal color temperature, R . Color temperature conversion filters alter the color temperature of a hypothetical blackbody radiator while maintaining its conformation to a blackbody source.

Some selective radiators, such as fluorescent lights, show emissions that do not match those of a blackbody radiator at any temperature. For these situations, a new value, correlated color temperature, is used. It is defined as the temperature of the blackbody radiator that most closely approximates the selective radiator in appearance at the same brightness and under specified viewing conditions. Given the (x, y) chromaticity coordinates, one can evaluate the correlated color temperature. The lines are based on the CIE 1931 (x, y) -chromaticity diagram. Figure 3 shows a portion of the CIE 1931 (x, y) -chromaticity diagram that includes chromaticity points of daylight compared to the chromaticity points implied by Planck's radiation law. The "daylight locus" in the figure is described by Eq. 2.

$$y_D = -3.000x_D^2 + 2.870x_D - 0.275. \quad (2)$$

A plot of these values is slightly above, but parallel to, the chromaticity points based on Planck's law. Selected isotherm-temperature lines are also given.

In some cases, the reciprocal color temperature, R (expressed in reciprocal megakelvins), provides a useful, alternative specification of color temperature for two reasons. First, a given change in the value of R (over small intervals) will produce equal perceptual changes for many color temperatures. Second, a given color temperature conversion filter will produce the same change in R over a wide range of color temperatures. This means that an observer's perceptions will undergo similar, predictable types of shifts with the application of color temperature conversion filters to different illuminants. Such conversion filters alter the color temperature of a hypothetical blackbody source while maintaining its conformation to a blackbody source. The color temperature of an illuminant using such a filter is given by Eq. (3).

$$K_{(\text{source} + \text{filter})} = 10^6 / (R_{\text{source}} + R_{\text{filter}}) \quad (3)$$

Table 1 shows the filters one may use to approximate one of the four CIE standard illuminants given in Table 2. The energy distributions in the visible spectrum for four CIE standard illuminants appear in Fig. 2.

Applications

When extended observations require constant, well specified illumination, the CIE standards will provide bases for establishing those conditions; filters can be used to bring nonstandard lights into conformity with required conditions.

Key References

1. Commission Internationale de l'Eclairage. (1931). *CIE Proceedings*. Cambridge, England: Cambridge University Press.
2. Judd, D. B. (1933). Sensibility to color-temperature change as a function of temperature. *Journal of the Optical Society of America*, 23, 7-14.
3. Moon, P. (1961). *The scientific basis of illuminating engineering*. New York: Dover.
4. Pokorny, J., & Smith, V. C. (1972). Color vision. In A. M. Potts (Eds.), *The assessment of visual function*. St. Louis: Mosby.
5. Pokorny, J., Smith, V. C., Verriest, G., & Pinckers, A. J. L. G. (1979). *Congenital and acquired color defects*. New York: Grune & Stratton.
- *6. Wyszecki, G., & Stiles, W. S. (1982). *Color science: Concepts and methods, quantitative data and formulae* (2nd ed.). New York: Wiley.

Cross References

- 1.108 Spectral transmittance and reflectance;
Handbook of perception and human performance,
 Ch. 8, Sect. 2.0

Table 1. Color temperature of CIE standard illuminants and the Kodak color compensating filters which can be used to reproduce (approximately) the standard when illuminating sources of different color temperatures are used. (From Handbook of perception and human performance)

		A	B	D₆₅	C
Color Temperature		2854	4874	6504	6774
Reciprocal MegaKelvins		350	205	154	148
2400	417	-67 82C + 82A	-210 80A + 80C	-263 80A + 80A	-269 80A + 80A
2600	385	-35 82B	-180 80A + 82C	-231 80A + 80B	-237 80A + 80B
2800	357	-7 82	-152 80A + 82A	-203 80A + 80C	-209 80A + 80C
3000	333	+17 80A	-128 80A	-179 80A + 82C	-185 80A + 80D
3200	312	+38 81C	-107 80B	-158 80B + 82C	-164 80A + 82B

The reciprocal color temperatures, R , (in reciprocal megakelvins) are displayed for each color temperature and the required value of R needed to convert the original source to match a standard illuminant. (If one were to use an illuminant with color temperature of 2800°K [357 reciprocal megakelvins], the source could be made to approximate a Standard illuminant C through the use of Kodak color compensating filters 80A + 80C. This would produce the requisite R value of -209).

Table 2. Relative spectral radiant power distributions of CIE standard illuminants A, B, C, and D_{65} .

Wavelength (nm)	A ($S(\lambda)$)	B ($S(\lambda)$)	C ($S(\lambda)$)	D_{65} ($S(\lambda)$)
300	0.93			0.03
310	1.36			3.30
320	1.93	0.02	0.01	20.20
330	2.66	0.50	0.40	37.10
340	3.59	2.40	2.70	39.90
350	4.74	5.60	7.00	44.90
360	6.14	9.60	12.90	46.60
370	7.82	15.20	21.40	52.10
380	9.80	22.40	33.00	50.00
390	12.09	31.30	47.40	54.60
400	14.71	41.30	63.30	82.80
410	17.68	52.10	80.60	91.50
420	20.99	63.20	98.10	93.40
430	24.67	73.10	112.40	86.70
440	28.70	80.80	121.50	104.90
450	33.09	85.40	124.00	117.00
460	37.81	88.30	123.10	117.80
470	42.87	92.00	123.80	114.90
480	48.24	95.20	123.90	115.90
490	53.91	96.50	120.70	108.80
500	59.86	94.20	112.10	109.40
510	66.06	90.70	102.30	107.80
520	72.50	89.50	96.90	104.80
530	79.13	92.20	98.00	107.70
540	85.95	96.90	102.10	104.40
550	92.91	101.00	105.20	104.00
560	100.00	102.80	105.30	100.00
570	107.18	102.60	102.30	96.30
580	114.44	101.00	97.80	95.80
590	121.73	99.20	93.20	88.70
600	120.04	98.00	89.70	90.00
610	136.35	98.50	88.40	89.60
620	143.62	99.70	88.10	87.70
630	150.84	101.00	88.00	83.30
640	157.98	102.20	87.80	83.70
650	165.03	103.90	88.20	80.00
660	171.96	105.00	87.90	80.20
670	178.77	104.90	86.30	82.30
680	185.43	103.90	84.00	78.30
690	191.93	101.60	80.20	69.70

The relative spectral radiant power $S(\lambda)$ in the table is computed for wavelengths of light in the near ultraviolet, visible spectrum, and near infrared regions.

From G. Wyszecki & W. S. Stiles, *Color science: Concept and methods, quantitative data and formulae* [2nd ed.]. Copyright 1982 by John Wiley & Sons, Inc. Reprinted with permission.

1.108 Spectral Transmittance and Reflectance

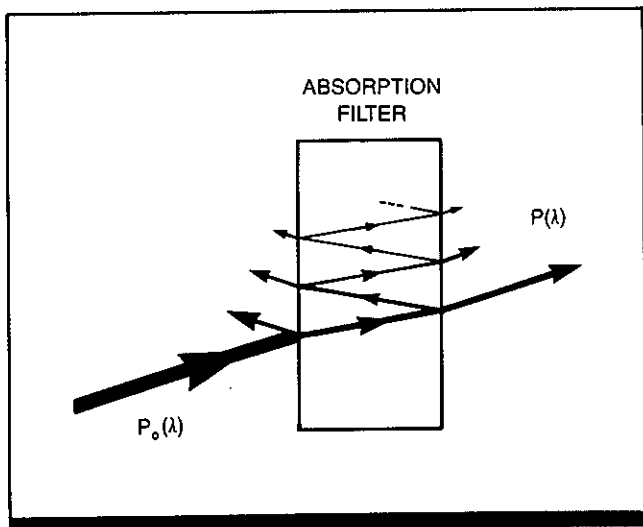

Figure 1. Schematic diagram showing the path of light through an incident to a transparent or translucent surface (absorption filter). Because no surface is completely transparent, there will always be some absorption by the filter, as well as reflection from the front and rear surfaces. $P_o(\lambda)$ indicates radiant flux arriving at the filter; $P(\lambda)$ depicts the emerging flux. (From G. Wyszecki & W. S. Stiles, *Color science: Concepts and methods, quantitative data and formulae* [2nd Ed.]. Copyright 1982 by John Wiley & Sons, Inc. Reprinted with permission.)

Key Terms

Absorption filter; beamsplitter; conversion filter; cut-off filter; cut-on filter; Fabry-Pérot filter; gelatin filter; glass filter; interference filter; liquid filter; passband filter; photometry; spectral reflectance; spectral transmittance; square-top multicavity filter

General Description

Color vision depends on the wavelengths of light emitted by a source or reflected from a surface. A transparent surface or object can be characterized by the wavelengths of the light that it absorbs and transmits because, in reality, all surfaces and objects will fail to transmit light at some wavelengths. This property is called spectral transmittance (τ). Figure 1 depicts what happens to light as it passes through an absorption filter (see Table 1). Some light is lost through reflection losses on the two surfaces of the filter, while other energy is lost by absorption in the filter. The human eye is a filtering system, with the cornea, lens, and ocular media absorbing radiation at selective wavelengths and transmitting at others (CRef. 1.202). When a color filter is used, the flux it transmits is its relative spectral emittance (S_e). Transmittance at a given wavelength λ , or $S_{e\lambda}$, is described by Eq. 1.

$$S_{e\lambda} = H_\lambda \tau_\lambda \tag{1}$$

where H_λ is the spectral emittance of the source at wavelength λ and τ_λ is filter transmittance at λ .

A solid object is typically characterized by its spectral

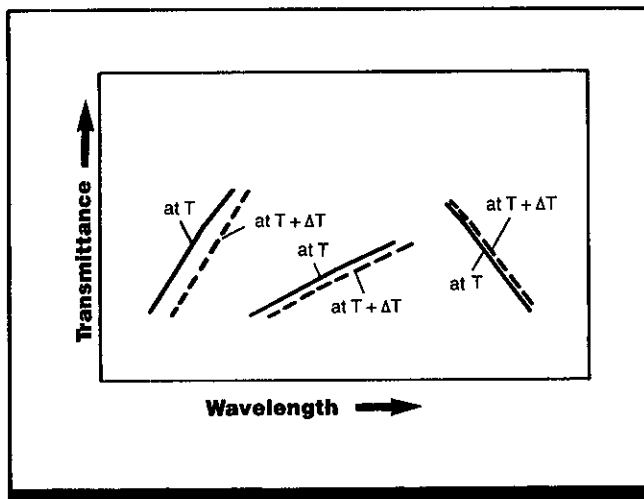

Figure 2. The effects of changes in temperature (ΔT) on the spectral transmittance curve of 3 glass filters. The change is temporary and the characteristics of the filter will return to their specified levels with a return to a given temperature. (From G. Wyszecki & W. S. Stiles, *Color science: Concepts and methods, quantitative data and formulae* [2nd Ed.]. Copyright 1982 by John Wiley & Sons, Inc. Reprinted with permission.)

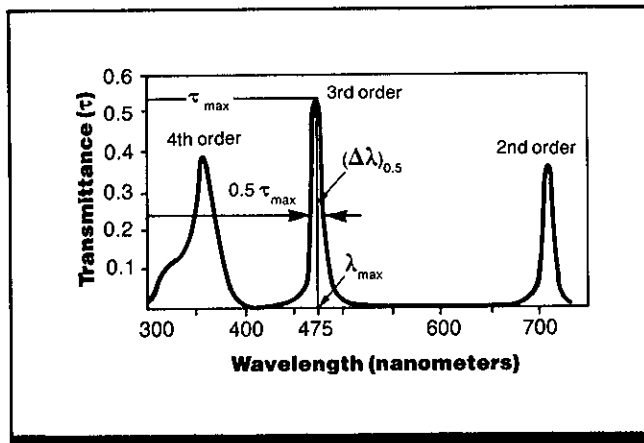

Figure 3. Spectral transmittance curve of a Fabry-Pérot-type (narrow-band) interference filter in the ultraviolet and visible spectrum. In this case, the third-order passband at 475 nm is at the desired wavelength; the second and fourth order passbands are undesirable and can be eliminated through the use of additional filters, either absorption or interference, although the transmittance at the desired wavelength is diminished. The half-width at 475 nm equals 10 nm here. (From G. Wyszecki & W. S. Stiles, *Color science: Concepts and methods, quantitative data and formulae* [2nd Ed.]. Copyright 1982 by John Wiley & Sons, Inc. Reprinted with permission.)

Table 1. Classes of filters useful in photometry, colorimetry, and vision research.

Type	Comments
Absorption Filters (General Applications)	
Glass	<ul style="list-style-type: none"> • If filters come from different batches or melts, slightly different spectral transmittance curves are not unusual. • Transmittance of glasses containing selenium oxide as a coloring agent are very sensitive to temperature changes. • Many glass filters emit visible light (fluoresce) with irradiation by ultraviolet energy. Filter combinations can help offset this problem. • Surfaces of some glass filters tarnish with exposure to atmosphere, high humidity, or high temperature for long durations. Hardening by manufacturers or protection by enclosing between two stable glasses can protect sensitive filters.
Gelatin	<ul style="list-style-type: none"> • Spectral transmittance of gelatin filters is often similar to that of colored glass filters. • Gelatin filters are less expensive than glass filters and can easily be cut to desired size and shape. • Gelatin filters are less stable than glass filters. • Gelatin filters are very delicate and, unlike glass filters, cannot be cleaned. They should not be touched by human skin. They are sometimes cemented between sheets of glass for protection. • Gelatin filters are seldom used in precision radiometry, photometry, or colorimetry.
Liquid	<ul style="list-style-type: none"> • These filters are available for a wide range of spectral transmittance curves. • Liquid filters are inconvenient to use compared to glass filters.
Absorption Filters (Special Applications)	
Heat-Absorbing Glasses	<ul style="list-style-type: none"> • These transmit near ultraviolet and visible spectral wavelengths, while absorbing heat-causing infrared wavelengths. • Optical quality of these glasses is typically not as high as for most other glass filters. For image transmission, rather than to filter a light source, high optical quality is required.
Color Temperature Conversion Filters	<ul style="list-style-type: none"> • These filters change the color temperature (Ref. 1.107), the spectral radiant power of light, either raising or lowering it. • These filters always deviate, to some extent, from the ideal filter; they can sometimes be improved by combining them with appropriate wide-band interference filters. • Color-temperature filters are used to alter the color temperature of a blackbody source while maintaining its conformation to a blackbody.
Filters for Calibration of Spectrophotometers	<ul style="list-style-type: none"> • These filters, with specified minima and maxima for certain wavelengths, can be used in initial calibration of spectrophotometers.
Interference Filters	
Fabry-Perot Filters	<ul style="list-style-type: none"> • These consist of two reflective thin films separated by a dielectric spacer layer; white light incident on these filters is transmitted in a highly selective manner.
All-Dielectric Multilayer Filters	<ul style="list-style-type: none"> • More modern than Fabry-Perot filters, these use all-dielectric multilayer stacks, silver films, which absorb and scatter very little. • High peak transmittances and narrow passbands are attainable.
Filter Wedges	<ul style="list-style-type: none"> • With these filters, the thickness of all the layers varies across the surface of the substrate, affecting transmittance in desired ways.

1.1 Measurement of Light

reflectance, although even "transparent" surfaces show reflectance. Reflectance (ρ) is the ratio of incident to reflected light at a surface. Measurements of reflectance are often compared to that of a uniformly reflecting surface, such as magnesium oxide.

The spectral transmittance properties of filters are highly useful in colorimetry and vision research. There are many types of filters. Those of most interest in colorimetry, and their limitations, are given in Table 1. Two particular parameters are useful in characterizing filters. The first is the wavelength at peak transmission at a single output. The peak value gives no information about the range of wavelengths transmitted, so a second parameter is needed, the half-width (or half-height bandwidth), which is one-half the difference between the wavelength values at either side of the point of peak transmittance at which transmittance falls to half the peak value (example shown in Fig. 3). In some cases, the half-width may not be a meaningful index of transmittance, as when a filter transmits only at one end of the spectrum (so-called pass, cut-on, cut-off filters).

Many manufacturers' catalogs specify their filters' transmittance characteristics, although there may be discrepancies between stated and actual properties, especially for glass filters. Empirical establishment of the spectral transmittance is desirable for each individual filter; such specifications are frequently available from the filter supplier when ordering. The temperature of a glass filter will alter its transmittance, as shown in Fig. 2. The effect is reversible, and the filter will return to its original transmittance at a specified temperature.

Absorption filters are one class of filters; the most commonly used kinds are glass, gelatin, or liquids containing coloring agents (for selective absorption). Such filters transmit light selectively and can be used in multfilter combinations, if desired. Direct photometric measurements of transmittance characteristics of a series of filters are to be preferred to mathematical calculations, due to the computational complexity in accounting for interreflections between filters. If interreflections can be ignored, calculations of transmittance are simple for filters in direct optical contact. Transmittance of the filter array at a given wavelength, $\tau_c(\lambda)$, is shown in Eq. 2:

$$\tau_c(\lambda) = [1 - (\rho\lambda)]^2 v_1(\lambda) v_2(\lambda) \dots v_k(\lambda) \quad (2)$$

where ρ is the reflectance at the j th surface, $v_i(\lambda)$ is the internal spectral transmittance of the i th component filter, λ is the wavelength of light in nanometers, and k is the total number of filters. For this equation to be valid, the cement between filters must have the same refractive index as that of the individual filters and must have negligible thickness and absorption. The transmittance of multiple filters separated by air can be calculated for filters with the same refractive index by:

$$\tau_c(\lambda) = [1 - \rho(\lambda)]^{2k} v_1(\lambda) v_2(\lambda) \dots v_k(\lambda) \quad (3)$$

where ρ is the reflectance at the j th surface, $v_i(\lambda)$ is the internal spectral transmittance of the i th component filter, λ is the wavelength of light in nanometers, and k is the number of filters. This equation reveals that the reflection loss in such a combination can be considerable.

Another type of filter is the interference filter, which consists of multiple layers of different materials deposited on an optical surface to control or modify the surface's reflection and transmission characteristics. If the reflecting

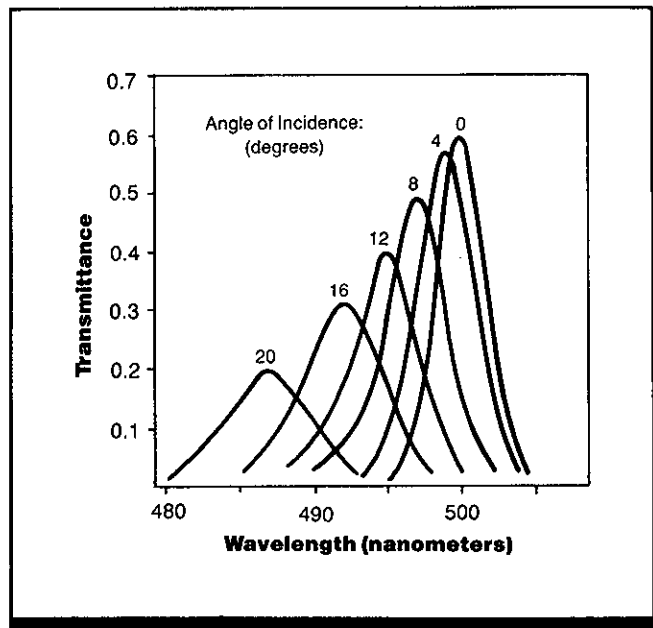

Figure 4. Effect of angle of incidence of light on transmittance of a typical passband filter. Greater eccentricity is associated with lower transmittance levels as well as lower wavelength peak transmittances. (From G. Wyszecki & W. S. Stiles, *Color science: Concepts and methods, quantitative data and formulae* [2nd Ed.]. Copyright 1982 by John Wiley & Sons, Inc. Reprinted with permission.)

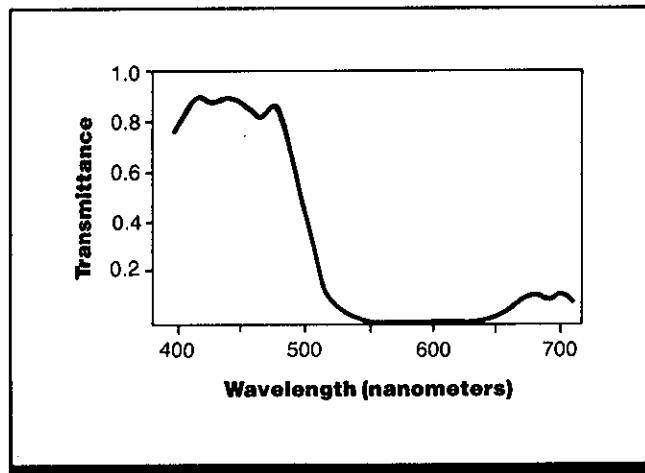

Figure 5. Spectral transmittance of a dichroic (color-selective) beamsplitter. (From G. Wyszecki & W. S. Stiles, *Color science: Concepts and methods, quantitative data and formulae* [2nd Ed.]. Copyright 1982 by John Wiley & Sons, Inc. Reprinted with permission.)

boundaries of these layers are sufficiently close, the reflected light becomes coherent and interference occurs, eliminating certain wavelengths of light. These filters are called Fabry-Pérot interference filters. The spectral transmittance function of such filters shows a series of clearly separate passbands across the spectrum corresponding to the orders of interference produced by the filter. An example of such a filter is shown in Fig. 3. The second- and fourth-order passbands are undesirable and can be eliminated by adding blocking filters. Unfortunately, these blocking filters also attenuate transmittance at the desired wavelength. Interference filters are susceptible to changes in transmittance

as a function of wavelength when the angle of incident light increases, as shown in Fig. 4. They also change in peak wavelength with temperature change.

A third means for filtering light is the beamsplitter, which separates incident light into two beams that diverge. These filters are dependent on the state of polarization of incident light. Figure 5 shows the transmittance of a dichroic or color-selective beamsplitter.

Reflectance is primarily used to characterize opaque surfaces. There has been considerable documentation of the reflectance of many natural and artificial surfaces. The reflection from these objects can be classified in several ways. Regular reflection (specular or mirror reflection) follows the law of optical reflection without irregular scattering of light; diffuse reflection follows no regular reflective pattern; mixed reflection is partly regular (specular) and partly diffuse. Figure 6 shows the reflectance properties of a magnesium oxide surface, the traditional basis of comparison for other surfaces. Figure 7 illustrates the reflective patterns of different artificial surfaces.

There are two main kinds of devices for measuring radiant energy: thermal detectors and photon detectors. Thermal detectors are, in theory, independent of wavelength of the radiant energy, although in practice, there are limitations to this independence. The limitations are inherent in the composition of the window materials placed in front of the actual detector. One of the notable disadvantages to most thermal detectors is their relatively long latency of response. Three widely used classes of thermal detectors include bolometers, thermocouples or thermopiles, and pyroelectric detectors. There is considerable variability of response across and within types. The pyroelectric detector responds faster than the others but is susceptible to vibrations, which increase noise in the response.

The operation of photon detectors is based on either an

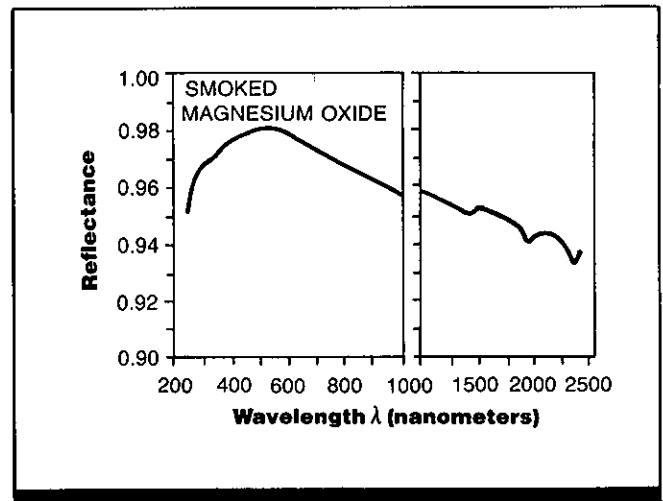

Figure 6. Absolute spectral reflectance curve for a uniformly reflecting surface of smoke-deposited magnesium oxide. (From G. Wyszecki & W. S. Stiles, *Color science: Concepts and methods, quantitative data and formulae* [2nd Ed.]. Copyright 1982 by John Wiley & Sons, Inc. Reprinted with permission.)

external or an internal photoelectric effect. In the external effect, the photon's energy is sufficient to free an electron from the surface of the photosensitive material, triggering a detection response. In the internal effect, the photon energy entering the system is too small to free an electron, but it is sufficient to alter semiconductor states in the measuring device. Because the photon energy is inversely proportional to its wavelength, photon detectors are most useful in the ultraviolet and visible radiometric spectrum.

Constraints

- Any measurement of transmitted or reflected light energy will be dependent on the nature of the points or surfaces from which light will radiate. Consistency of observation will depend on unvarying viewing conditions, which can be created when one knows the properties of the objects in question, and which can be verified with appropriate photometric measurement devices.

Key References

1. Scharf, P. T. (1965). Filters. In R. Kingslake (Ed.) *Applied Optics and Optical Engineering*, (Vol. 1). New York: Academic Press.
2. Wyszecki, G., & Stiles, W. S. (1982). *Color science: Concepts and methods, quantitative data and formulae* (2nd Ed.) New York: Wiley.

Cross References

- 1.104 Measurement of radiant and luminous energy;
- 1.107 Color temperature;
- 1.202 Transmissivity of the ocular media

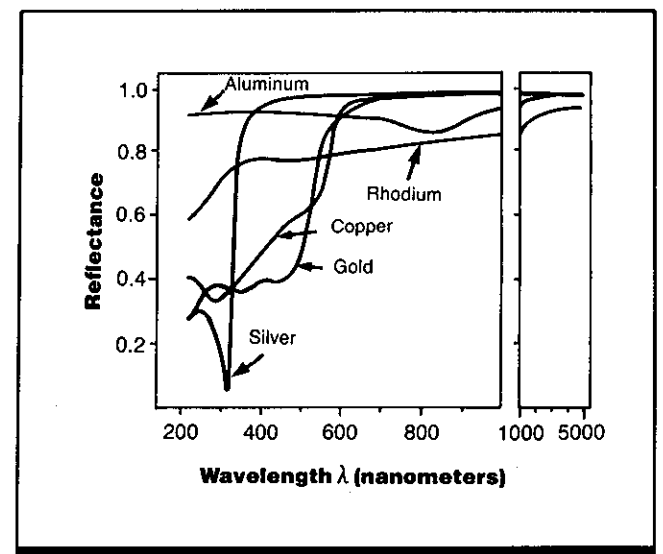

Figure 7. Spectral reflectance curves for surfaces coated with aluminum (Al), silver (Ag), gold (Au), copper (Cu) and rhodium (Rh) for use as front-surface mirrors. (From G. Wyszecki & W. S. Stiles, *Color science: Concepts and methods, quantitative data and formulae* [2nd Ed.]. Copyright 1982 by John Wiley & Sons, Inc. Reprinted with permission.)

1.109 Photometric Techniques for Measuring Spectral Sensitivity

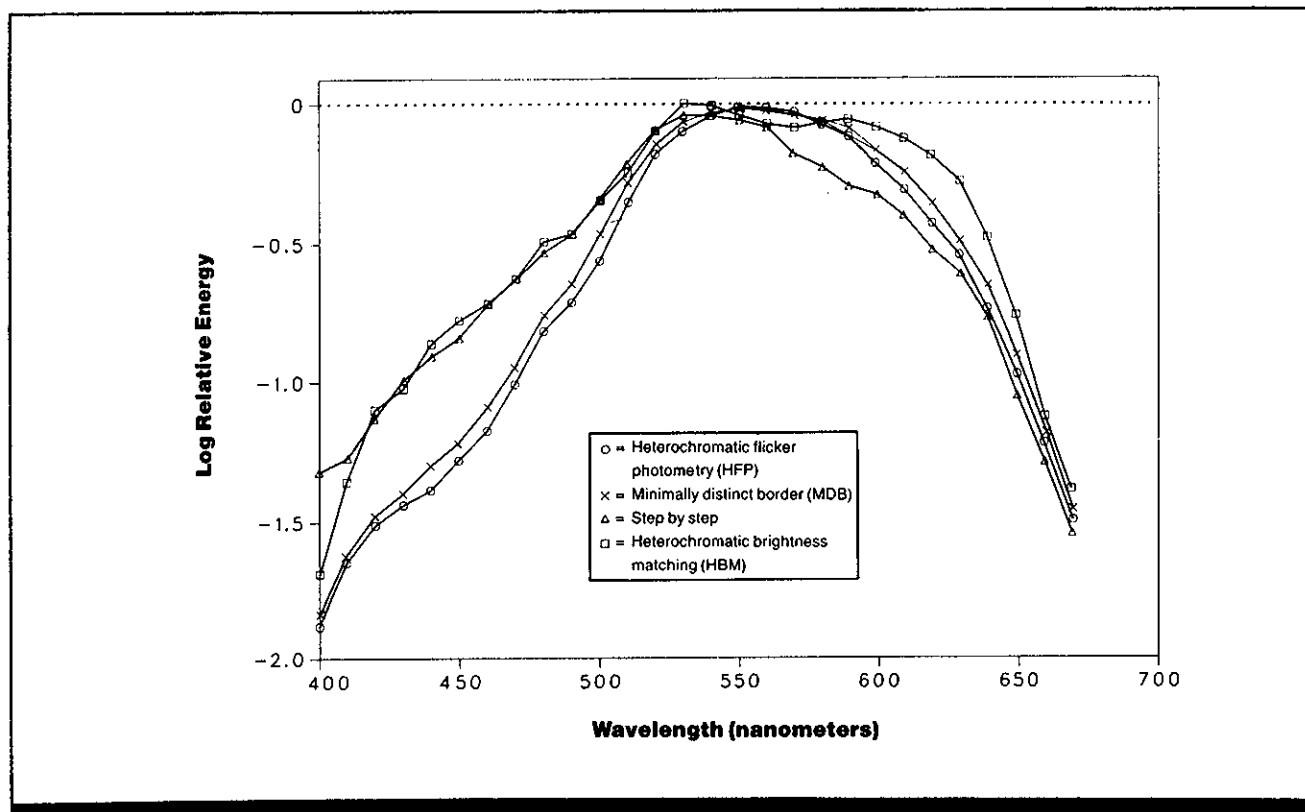

Figure 1. Relative foveal spectral sensitivity as measured by four different methods. Data are averages for four observers with normal color vision for a 1-deg 40-min visual field. Values plotted are logarithms of values listed in Table 2. (From Ref. 10)

Key Terms

Brightness; heterochromatic brightness matching; heterochromatic flicker photometry; luminosity; luminosity function; luminous efficiency; minimally distinct border technique; photometry; spectral sensitivity; step-by-step brightness matching; wavelength

General Description

The human eye is differentially sensitive to various wavelengths in the visible spectrum. The relative sensitivity of the eye at each wavelength is described by a **luminous efficiency function** (CRef. 1.110). Luminous efficiency functions have been measured for the daylight-adapted eye (**cone** or **photopic** vision), the dark-adapted eye (**rod** or **scotopic** vision), and mixed (rod and cone, or **mesopic**) vision.

Luminous efficiency (spectral sensitivity) has been measured by several different methods, which are summarized in Table 1. The photopic luminous efficiency function varies depending on measurement technique. In general, direct visual photometry, in which adjacent patches of different chromaticity are adjusted until they appear equally bright (heterochromatic brightness matching), is difficult and pro-

duces variable responses. Indirect visual methods (such as heterochromatic flicker photometry) are easier to use and generate more precise results.

Heterochromatic flicker photometry and the method of minimally distinct border yield very similar results, while step-by-step and heterochromatic brightness matching yield results that differ from the first two techniques as well as from each other. Figure 1 and Table 2 show the relationship among techniques and the results they generate. Substantial inter-subject variability has been found due primarily to variations in retinal pigmentation and variation in the ratio of photoreceptor types in the eye. Also, the data for visual fields with angular subtense <4 deg differ from the results for larger fields.

Abney's law states that the total luminance of a complex light (light of mixed wavelengths) is equal to the sum of the

luminances of the monochromatic components of the light. This principle of additivity holds for heterochromatic flicker photometry and minimally distinct border techniques, but breaks down with brightness matching techniques. For example, with two bipartite fields, each having a white reference patch on one half and a chromatic patch on the other, an observer can match the brightness of the white patches to their corresponding chromatic patches. If the two white fields are then added together and the two chromatic patches are added, the chromatic and the white areas may no longer appear equally bright.

Such variations with measurement technique do not appear at scotopic levels of illumination, at least for absolute

threshold and brightness matching techniques. Scotopic heterochromatic sensitivity functions depend on field size and radiance levels.

In practical photometry, heterochromatic flicker photometry is the most relevant technique when the brightness of different colored lights is to be compared and specified in terms related to actual visual experience. The Commission Internationale de l'Eclairage has adopted a standard photopic luminous efficiency function based on data collected using heterochromatic flicker photometry and step-by-step brightness matching, and a standard scotopic luminous efficiency function based on data from brightness-matching and absolute threshold studies (CRef. 1.110).

Table 1. Methods of measuring spectral sensitivity.

Technique/Viewing Conditions	Comments
<p>Absolute Foveal Threshold</p> <p>Monochromatic light of specified dimensions and retinal locus is presented in brief, repeated flashes. Minimum radiance required by the observer for detection defines the absolute threshold. Foveal presentation involves test light of 1 deg visual angle or less.</p>	<p>Different wavelengths of test light may be tapping separate cone (photopic) systems. Level of adaptation may be crucial.</p>
<p>Heterochromatic Brightness Matching (HBM)</p> <p>Centrally viewed (foveal) bipartite (split) field is used. Reference field is usually white or fixed monochromatic light. The observer fixates on the dividing line and adjusts the test field to match the reference field in brightness. The observer is to concentrate on brightness and ignore hue and saturation. The task is difficult.</p> <p>With larger fields, color differences may necessitate supplementary conditions to ensure unambiguous judgment by the observer. Such adjustments include providing a surround of appropriate color as well as relaxing the stricture that the observer fixate continuously on the line dividing the two halves of the field and instead having the observer alternate glances between the two fields and the surround.</p>	<p>Considerable variability both within and across observers.</p>
<p>Step-by-Step Technique</p> <p>Special case of heterochromatic brightness matching. Many reference lights are used. Both reference and test lights are monochromatic, with wavelengths only a few nanometers apart. This keeps hue and saturation differences from distorting brightness matches.</p>	<p>Easier than heterochromatic brightness matching for some observers.</p>
<p>Heterochromatic Flicker Photometry (HFP)</p> <p>Two light patches of the same size and shape alternate on same retinal location. One light has known luminance and serves as a reference; its radiance remains fixed. The radiance of the second light is varied until the sensation of flicker is eliminated or minimized. The adjusted light is usually monochromatic; the reference light may not be.</p>	<p>Alternation rate at which flicker is minimized depends on the wavelength of the adjusted light, the radiance of the reference light, and field size.</p>
<p>Minimally Distinct Border (MDB)</p> <p>Two contiguous lights are presented with their borders precisely juxtaposed. The radiance of one light is adjusted until the border between the two lights is minimal. The reference (fixed) field is usually of a white appearance; the adjusted (test) field is usually monochromatic.</p>	<p>This procedure is as reliable as heterochromatic flicker photometry. Targets with different chromaticities may show minimally distinct borders with higher levels of contrast between test and reference fields.</p>

Constraints

- Spectral sensitivity varies with the level of illumination to which the observer is adapted.
- Spectral sensitivity varies with field size; in addition, for large (>2 deg) visual fields, there may be inhomogeneities in the appearance of the test light.
- There are large individual differences in spectral sensitivity.

Key References

1. Burns, S. A., Smith, V. C., Pokorny, J., & Elsner, A. E. (1982). Brightness of equal-luminance lights. *Journal of the Optical Society of America*, 72, 1225-1231.

2. Dresler, A. (1953). The non-additivity of heterochromatic brightness. *Transactions of the Illuminating Engineering Society (London)* 18, 141-165.

3. Eisner, A., & MacLeod, D. I. A. (1981). Flicker photometric study of chromatic adaptation: Selective suppression of cone inputs by colored backgrounds. *Journal of the Optical Society of America*, 71, 705-717.

4. Gibson, K. S., & Tyndall, E. P. T. (1923). Visibility of radiant energy. *Bulletin Bureau of Standards*, 19, 131.

5. Guth, S. L., Donley, N. J., & Marrocco, R. T. (1969). On luminance additivity and related topics. *Vision Research*, 9, 537-575.

6. Ikeda, M., & Shimozono, H. (1981). Mesopic luminous-efficiency functions. *Journal of the Optical Society of America*, 71, 280-284.

7. Kaiser, P. K., & Wyszecki, G. (1978). Additivity failures in heterochromatic brightness matching. *Color Research and Applications*, 3, 177-182.

8. Richards, W., & Luria, S. M. (1964). Color-mixture functions at low luminance levels. *Vision Research*, 4, 281-313.

9. Sperling, H. G. (1961). An experimental investigation of the relationship between colour mixture and luminous efficiency. In *National Physical Laboratory Symposium on the Visual Problems of Colour* (Vol. 1). New York: Chemical Publishing.

10. Wagner, G., & Boynton, R. M. (1972). Comparison of four methods of heterochromatic photometry. *Journal of the Optical Society of America*, 62, 1508-1515.

11. Walters, H. V., & Wright, W. D. (1943). The spectral sensitivity of the fovea and extrafovea in the Purkinje range. *Proceedings of the Royal Society of London*, 131B, 340-361.

12. Wyszecki, G., & Stiles, W. S. (1982). *Color science— Concepts and methods, quantitative data and formulae* (2nd ed.). New York: Wiley.

Cross References

1.102 Spectral distribution of radiant energy;

1.110 Luminous efficiency (spectral sensitivity);

1.303 Equal-brightness and equal-lightness contours for targets of different colors (spectral content); *Handbook of perception and human performance*, Ch. 8, Sect. 2.2.5

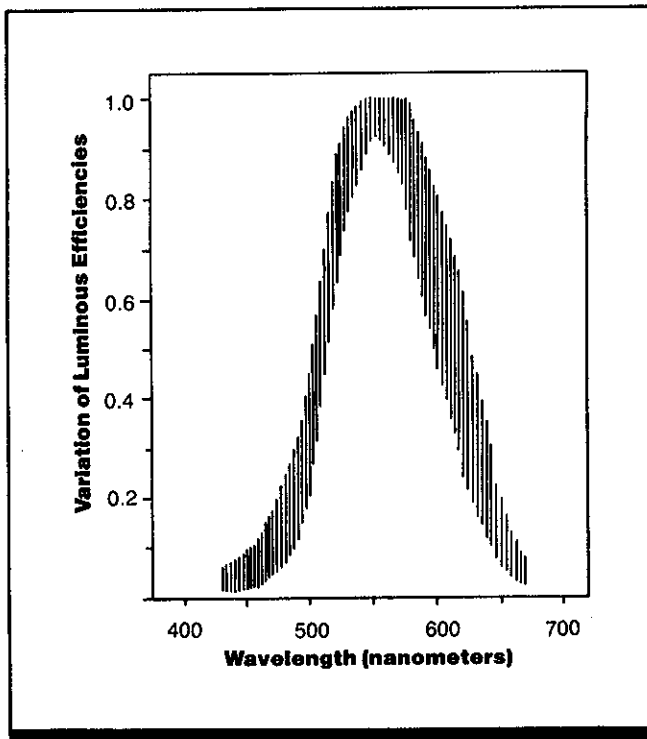

Figure 2. Range of luminous efficiency values for 52 observers, obtained by the step-by-step method. Each individual function was normalized to unity at its maximum value. (From G. Wyszecki & W. S. Stiles, *Color science: Concepts and methods, quantitative data and formulae* [2nd ed.]. Copyright 1982 by John Wiley & Sons, Inc. Reprinted with permission.)

**Table 2. Luminous efficiency function obtained by four different techniques.
(From Handbook of perception and human performance)**

Wavelength (nm)	HFP	MDB	Step-by-Step	HBM
400	0.0128	0.0144	0.0470	0.0202
410	0.0222	0.0236	0.0538	0.0436
420	0.0301	0.0329	0.0748	0.0800
430	0.0361	0.0402	0.1010	0.0941
440	0.0410	0.0505	0.1250	0.1555
450	0.0525	0.0616	0.1445	0.1650
460	0.0681	0.0817	0.1920	0.1870
470	0.0985	0.1145	0.2400	0.2370
480	0.1518	0.1715	0.3010	0.3285
490	0.1950	0.2280	0.3420	0.3530
500	0.2782	0.3470	0.4630	0.4500
510	0.4550	0.5330	0.6320	0.5870
520	0.6790	0.7500	0.8450	0.8080
530	0.8315	0.8880	0.9540	1.0000
540	0.9410	0.9750	1.0000	1.0000
550	0.9891	0.9970	0.9200	0.9420
560	1.0100	0.9880	0.8360	0.8530
570	0.9670	0.9390	0.6980	0.8310
580	0.8935	0.9060	0.6200	0.8710
590	0.8035	0.8560	0.5360	0.9130
600	0.6450	0.6930	0.4970	0.8600
610	0.5200	0.5950	0.4170	0.7920
620	0.3880	0.4640	0.3200	0.6880
630	0.2945	0.3340	0.2570	0.5550
640	0.1890	0.2340	0.1760	0.3490
650	0.1082	0.1295	0.0925	0.1825
660	0.0615	0.0678	0.0550	0.0765
670	0.0321	0.0358	0.0299	0.0431

Relative sensitivity of the eye to lights of various wavelengths, as measured by heterochromatic flicker photometry (HFP), minimally distinct border (MDB), heterochromatic brightness matching (HBM), and step-by-step brightness matching. Data are averages for four observers (based on data from Ref. 10). Data are normalized to an equal energy spectrum.

1.110 Luminous Efficiency (Spectral Sensitivity)

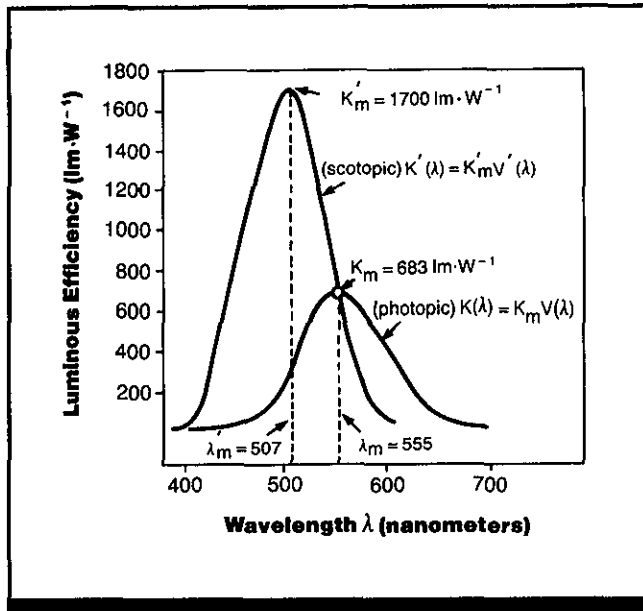

Figure 1. Spectral luminous efficiency functions for photopic $K(\lambda)$ and scotopic $K'(\lambda)$ vision. Note that photopic efficiency is lower at its peak than is scotopic efficiency at its peak. These functions derived from 1924 (photopic) and 1951 (scotopic) CIE establishment of photopic and scotopic standard observers. K_m and K'_m are the maximum photopic and scotopic luminous efficiencies, respectively. (From G. Wyszecki & W. S. Stiles, *Color science: Concepts and methods, quantitative data and formulae* 2nd ed.]. Copyright © 1982 by John Wiley & Sons, Inc. Reprinted with permission.)

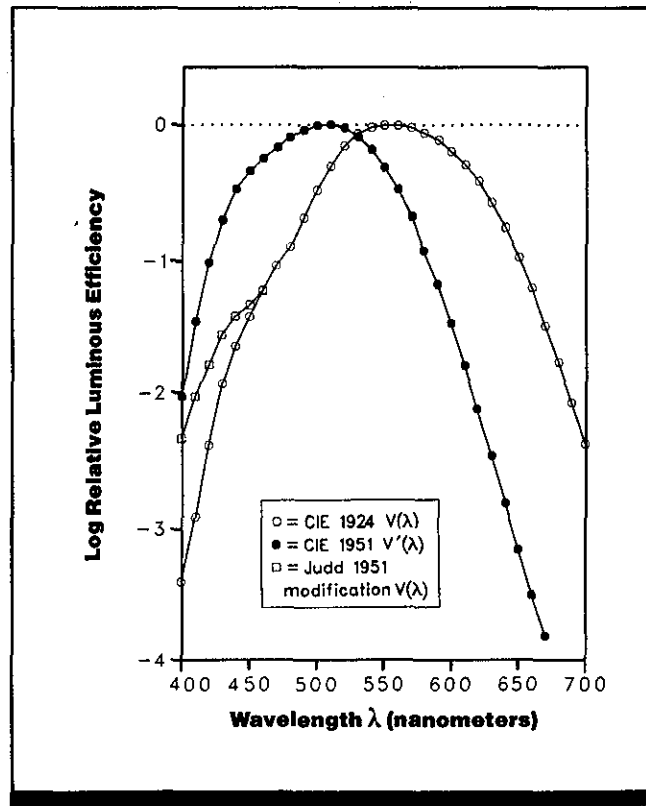

Figure 2. Luminous efficiency functions of CIE 1924 standard observer $V(\lambda)$ for photopic vision and CIE 1951 standard observer $V'(\lambda)$ for scotopic vision. Also shown is Judd's (Ref. 7) modification of CIE 1924 $V(\lambda)$ function in the blue end of the spectrum. The CIE 1924 $V(\lambda)$ and Judd modified $V(\lambda)$ are for a 2° foveally fixated field. The CIE 1951 $V'(\lambda)$ is for a completely dark adapted observer under age 30. Functions are derived from 1924 and 1951 CIE functions. (From *Handbook of perception and human performance*)

Key Terms

Brightness; luminosity; luminosity function; luminous efficiency; mesopic vision; photometry; spectral sensitivity

General Description

The human eye is differentially sensitive to wavelengths in the visible spectrum ($\sim 400\text{-}700\text{ nm}$). The wavelength region of maximal sensitivity differs for daylight-adapted (**photopic**) vision, dark-adapted (**scotopic**) vision, and mixed (**mesopic**) vision. The spectral *luminous efficiency function* describes the relative response of the eye as a function of wavelength. Figure 1 shows such functions for photopic and scotopic vision. The wavelengths of maximal sensitivity differ for the two systems, with the scotopic system showing greater sensitivity for short wavelengths, and the photopic for longer wavelengths. As the figure shows, the scotopic system is much more sensitive than the photopic system.

The Commission Internationale de l'Éclairage (CIE) has adopted a standard photopic luminous efficiency function, $V(\lambda)$, as well as scotopic function $V'(\lambda)$, for a standard observer. These functions are shown in Fig. 2. Values for each curve are normalized on the wavelength of greatest sensitivity, which is assigned a value of 1.0 (shown as zero on the logarithmic scale used in the figure). It has been shown that the CIE $V(\lambda)$ function underestimates the true luminous efficiency at short wavelengths. A subsequent modification to the function has been suggested (Ref. 7), which is also shown in the figure. The functions in Fig. 2 are applicable only for visual fields subtending $<4^\circ$. Figure 3 shows the photopic function for larger visual fields. Mesopic luminous efficiency functions for several different levels of illumination are given in Fig. 4.

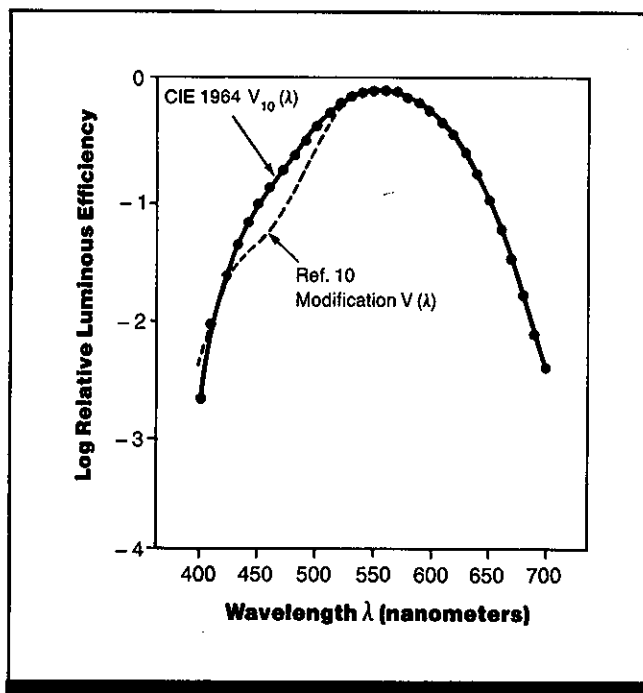

Figure 3. CIE 1964 luminous efficiency function $V_{10}(\lambda)$ for large (10 deg), centrally foveated field at photopic levels; the curves are based on color-matching data. For comparison purposes, the modification to the CIE 1924 luminous efficiency function for small fields is shown. $V_{10}(\lambda)$ is the same as the CIE 1964 $y_{10}(\lambda)$ color-matching function. (From G. Wyszecki & W. S. Stiles, *Color science: Concepts and methods, quantitative data and formulae* [2nd ed.]. Copyright © 1982 by John Wiley & Sons, Inc. Reprinted with permission.)

Constraints

- Luminous efficiency functions vary depending on measurement method used (CRef. 1.109).
- There are large individual differences in spectral sensitivity (CRef. 1.109).

Key References

1. Commission Internationale de l'Eclairage (1926). *CIE Proceedings 1924*. Cambridge, England: Cambridge University Press.
2. Commission Internationale de l'Eclairage (1932). *CIE Proceedings 1931*. Cambridge, England: Cambridge University Press.
3. Commission Internationale de l'Eclairage (1951). *CIE Proceedings 1951*. Cambridge, England: Cambridge University Press.
4. Commission Internationale de l'Eclairage (1978). *CIE Proceedings 1978*. Cambridge, England: Cambridge University Press.
5. Guth, S. L., Donly, N. J., & Marrocco, R. T. (1969). On luminance additivity and related topics. *Vision Research*, 9, 537-575.
6. Ikeda, M., & Shimozono, H. (1981). Mesopic luminous-efficiency functions. *Journal of the Optical Society of America*, 71, 280-284.
7. Judd, D. B. (1951). Colorimetry and artificial daylight. In *Technical Committee No. 7, International Commission on Illumination* (12th Session, pp. 1-60). Stockholm, Sweden: International Commission on Illumination.
8. Kaiser, P. K., & Wyszecki, G. (1978). Additivity failures in heterochromatic brightness matching. *Color Research and Applications*, 3, 177-182.
9. Kokoschka, S. (1972). Untersuchungen zur mesopischen Strahlensbewertung. *Die Farbe*, 21, 39-112.
10. Sperling, H. G. (1961). An experimental investigation of the relationship between colour mixture and luminous efficiency. In *National Physical Laboratory Symposium on the Visual Problems of Colour* (Vol. 1). New York: Chemical Publishing.
11. Wagner, G., & Boynton, R. M. (1972). Comparison of four methods of heterochromatic photometry. *Journal of the Optical Society of America*, 62, 1508-1515.
12. Walters, H. V., & Wright, W. D. (1943). The spectral sensitivity of the fovea and extrafovea in the Purkinje range. *Proceedings of the Royal Society of London*, 131B, 340-361.
13. Wyszecki, G., & Stiles, W. S. (1982). *Color science: Concepts and methods, quantitative data and formulae* (2nd ed.). New York: Wiley.

Cross References

- 1.102 Spectral distribution of radiant energy;
- 1.109 Photometric techniques for measuring spectral sensitivity;

1.302 Spectral sensitivity;
Handbook of perception and human performance, Ch. 8, Sect. 2.3

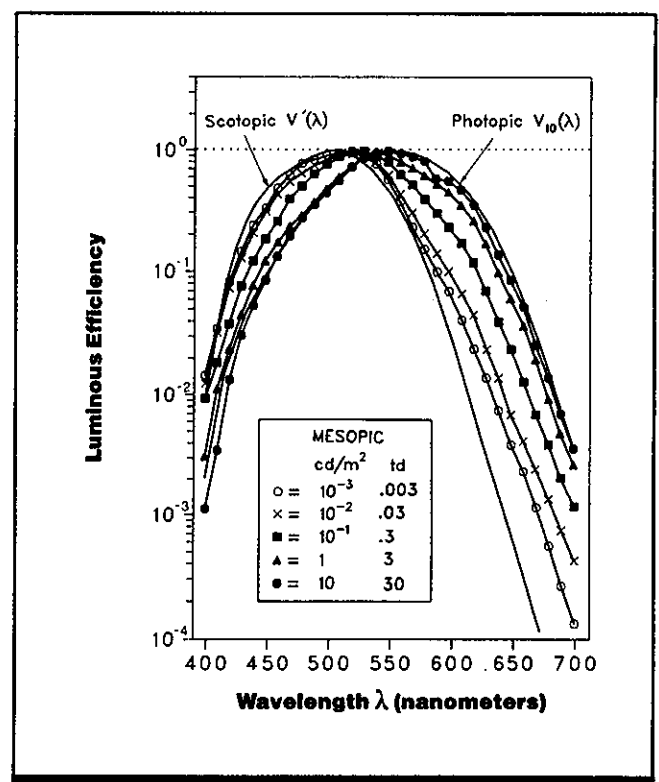

Figure 4. Mean mesopic luminous efficiency functions for three observers (aged 27 to 32) with central viewing of a large (9.5 deg) field. The observers made direct heterochromatic brightness matches between quasi-monochromatic test stimuli and a 530-nm reference stimulus of the luminance indicated in the key, seen through a 3-mm artificial pupil. The heavy lines represent the standard scotopic luminous efficiency function $V'(\lambda)$ and the photopic $V_{10}(\lambda)$ function. With decreases in luminance, the spectral sensitivity function gradually shifts from the photopic to the scotopic function. (From G. Wyszecki & W. S. Stiles, *Color science: Concepts and methods, quantitative data and formulae* [2nd ed.]. Copyright © 1982 by John Wiley & Sons, Inc. Reprinted with permission.)

1.111 Luminous Efficiency: Effect of Pupil Entry Angle

Key Terms

Brightness; effective pupil area; luminosity; luminous efficiency; Stiles-Crawford effect

General Description

In photopic (cone) vision, the apparent brightness (**luminous efficiency**) of a narrow beam of light entering near the edge of an observer's pupil is less than when it passes through the center of the pupil (Fig. 1). This phenomenon is known as the Stiles-Crawford effect. Figure 2 shows how relative luminous efficiency decreases as rays of light enter the eye increasingly further from the center of the pupil.

Because of this effect, the apparent brightness of an object is not simply proportional to the area of the pupil through which the light has passed. Figure 3 shows the relationship between the *effective pupil area* (i.e., pupil area corrected for the Stiles-Crawford effect) and the true pupil area. The effective pupil-true pupil area relationship is expressed as the *effectivity ratio*, which decreases as pupil diameter increases. To correct for the Stiles-Crawford phenomenon, effective, rather than true, pupil area is used to calculate retinal illuminance. To determine effective pupil area, calculate the effectivity ratio:

$$\text{Effectivity Ratio} = 1 - 0.0106d^2 + 0.0000419d^4, \quad (1)$$

where d is the true pupil diameter in millimeters.

Applications

Prevention of measurement error or loss of precision in optical devices, such as telescopes and photometric instruments, and in other situations where direct view (**Maxwellian view**) is used. Correction of visual brightness measurements for pupil diameter should include the Stiles-Crawford calculation, when relevant.

Methods

Test Conditions

- Circular, uniformly illuminated fixation field with angular diameter of 1 deg; image centered on viewer's chemically dilated pupil; monocular viewing; unused eye occluded; head constrained by biteplate; room darkened
- Fixed beam image with 0.75-mm diameter, variable beam image with 0.5-mm diameter; beams set to enter eye in parallel through a system of prisms, lenses, and a plain glass mirror; variable light beam presented in ~1-mm steps along horizontal and vertical axes through center of pupil
- Fixed and adjustable-brightness light beam images presented to one eye; retinal illuminance

(45 trolands) equivalent to external brightness of 0.56 cd/m² viewed through a 3-mm diameter aperture (artificial pupil); color temperature ~2300 deg (absolute)

Experimental Procedure

- Equality-of-brightness matches of fixed and variable beams using method of adjustment of flicker fusion
- Independent variable: point of pupil entry of variable light beam
- Dependent variable: luminance at which variable light beam appeared equal in brightness to fixed beam
- Observer's task: adjust rate of flicker until fixed and variable beam images appeared fused into single, evenly bright image

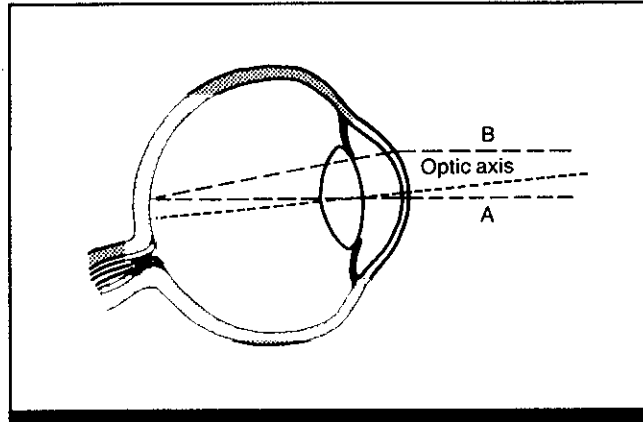

Figure 1. Identical light rays, A and B, enter the eye at the same angle and fall on the same retinal point. A, entering at the center of the pupil, is perceived as being brighter than B, which enters at the periphery of the pupil. (From Ref. 5)

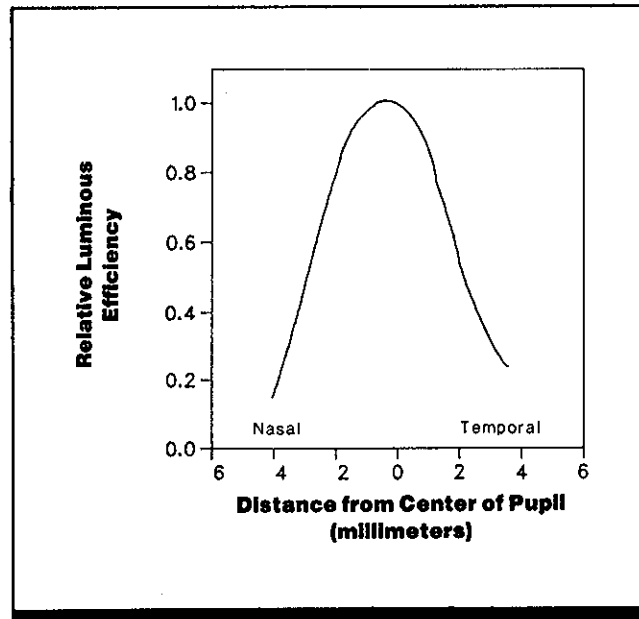

Figure 2. Typical Stiles-Crawford effect for light reception in the fovea of the eye. Shown is the relative luminous efficiency of a narrow bundle of light rays entering the eye away from the center of the pupil along the horizontal meridian at the distance shown. (Actual values may differ from observer to observer.) (From Ref. 6)

Experimental Results

- Apparent brightness (luminous efficiency) of a beam of light decreases as point of entry of the beam moves away from the pupil center either vertically or horizontally. Brightness near the periphery of the pupil falls to ~21-33% of the brightness at the center, depending upon subject, meridian orientation, and meridian extreme (Fig. 2).
- Point of greatest apparent brightness (efficiency) does not necessarily coincide exactly with center of pupil but varies with subject and meridian orientation (Fig. 2).

Variability

Measurements repeated after 6 weeks show significant curve shape difference for one observer but no significant change for another. Retinal location of curve peak differs for horizontal and vertical meridians of one subject. Minimum of nasal and temporal extremes differ by ~20% for one observer with eccentric pupil opening relative to outer edge of iris; nasal-temporal extreme values differ by ~10% for another observer, upper-lower extremes differ by ~15%.

Shapes of vertical and horizontal meridian curves are similar across observers. Location of point of maximum value along axis varies among observers. Minimum values vary among observers, ranging from ~20% to one-third or more of maximum values.

Repeatability/Comparison with Other Studies

Results were confirmed in a second experiment using direct equality-of-brightness matches of a divided circular target field for one set of measurements for 1 observer. Computed relative luminous efficiencies for overall pupil areas, using data from above studies, were checked by a third experi-

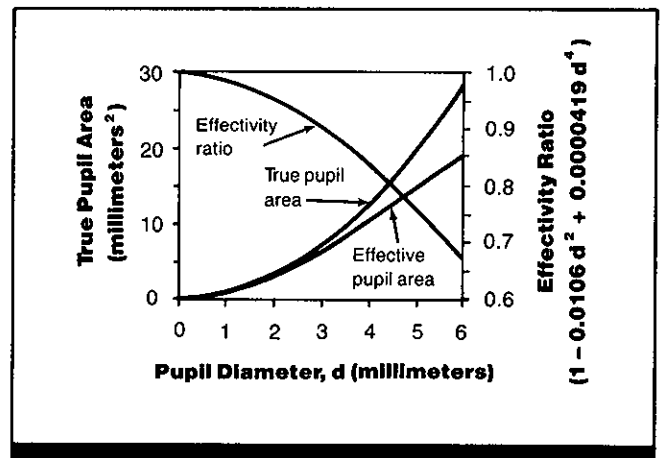

Figure 3. Relationship between actual pupil area (left ordinate scale) and effective pupil area for increasing pupil diameter. Effectivity ratio (of true to effective pupil area) calculated according to Eq. 1 is also shown (right ordinate scale). (From Ref. 4)

ment obtaining equality-of-brightness matches for two concentric rings of light at 12 apertures, from 0.75-6.25 mm. Data (adapted in Fig. 3) confirm calculated predicted changes of effective pupil area with change in true pupil area, indicating that changes are due to varying contributions of light rays entering the pupil at different points.

Constraints

- Because the Stiles-Crawford decrease in sensitivity occurs only for the cones and not for the rods, correction for it is necessary only when cone (color) vision is involved.

- To minimize error, for measurements using direct (Maxwellian) view, the viewing aperture (artificial pupil) of instrumentation must be carefully centered with the observer's natural pupil.
- Similar functions apply to other meridians.

Key References

1. Enoch, J.M., & Bedell, H.E. (1981). The Stiles-Crawford effects. In J.M. Enoch, & F.L. Tobey (Eds.), *Vertebrate photoreceptor optics*. Berlin: Springer-Verlag.
2. Farrell, R.J., & Booth, J.M. (February, 1984). *Design hand-*

book for imagery interpretation. Seattle, WA: Boeing Aerospace Co.

3. Graham, C.H. (1965). *Vision and visual perception*. New York: Wiley.
4. Jacobs, D.H. (1944). The Stiles-

Crawford effect and the design of telescopes. *Journal of the Optical Society of America*, 34, 694.

- *5. Stiles, W.S., & Crawford, B.H. (1933). The luminous efficiency of rays entering the eye pupil at different points. *Proceedings of the Royal Society of London*, B112, 428-450.

6. Westheimer, G. (1986). The eye as an optical instrument. In K.R. Boff, L. Kaufman, & J.P. Thomas (Eds.), *Handbook of perception and human performance: Vol. 1. Sensory processes and perception*. New York: Wiley.

Cross References

- 1.213 Diffraction of light in optical systems

Notes



Section 1.2 Optics of the Eye

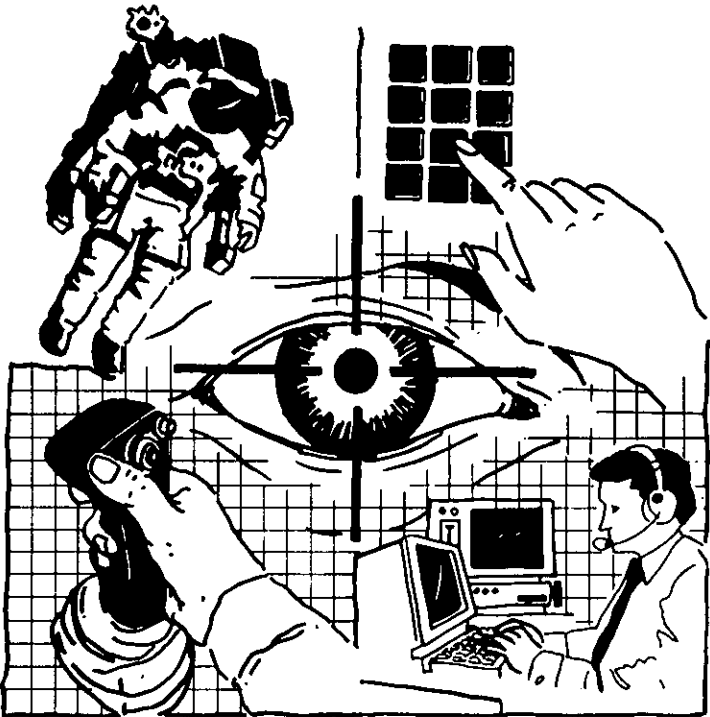

1.201 Anatomy of the Human Eye

Key Terms

Cornea; eye focus; eyeball; fovea; lens; macula lutea; ocular media; refraction; retina

General Description

The anatomical structure of the eye is roughly analogous to the optical imaging apparatus of a camera. The eye focuses rays of light from objects in the visual field so that a reasonably accurate, integrated image forms at the back of the eye, on the retina. The eyes of young adults with normal vision differ little from one another.

The eye is nearly spherical, with a diameter of 20-25 mm. It is surrounded by two membranes: the *cornea*, which covers the front surface of the eye; and the *sclera*, which joins the cornea and completely encloses the rest of the eye. The *retina* lines the back wall of the eye and contains photoreceptors, an elaborate network of nervous tissue, and blood vessels.

The cornea covering the front of the eyeball is strongly curved and clear. Behind it is the *anterior chamber*, which contains a nutrient- and oxygen-carrying liquid called the *aqueous humor*. The cornea and the aqueous humor constitute a strong, fixed-focus lens system that provides about two-thirds of the total refractive or focusing power of the eye.

Behind the anterior chamber is an elastic *lens* whose thickness (and hence focusing power) is under nervous and muscular control. After the cornea, the much-weaker lens contributes most of the focusing power of the eye. Because of the variable refractive power of the lens (accomplished through changes in its shape and thickness referred to as *accommodation*), the lens permits the eye to remain in good focus for objects at different distances (CRef. 1.222). The lens contains a slightly yellowish pigmentation which reduces transmission of light at the short-wavelength (ultraviolet) end of the visible spectrum. This pigmentation increases slightly with age.

Light enters the eye at the cornea and passes through the pupil, an aperture formed by the iris. The light then passes through the lens and is brought to a focus on the retina. After the light from the imaged object has passed through the network of nerve fibers and blood vessels that form the front layers of the retina, it reaches the **photoreceptors**, the **rods** and **cones**, and the optical image formed on the retina is transduced into nervous impulses. Rods are responsible for night vision and cones for vision in daylight. The 120 million rods contain the pigment rhodopsin; cones, which mediate color vision, contain one of three different pigments, each of which shows maximum light absorption at a slightly different wavelength. There are approximately seven million cones.

Behind the retinal receptors are the *pigment epithelium* and the *choroid coat*. The choroid coat contains a network of blood vessels and is the first layer inside the sclera. The

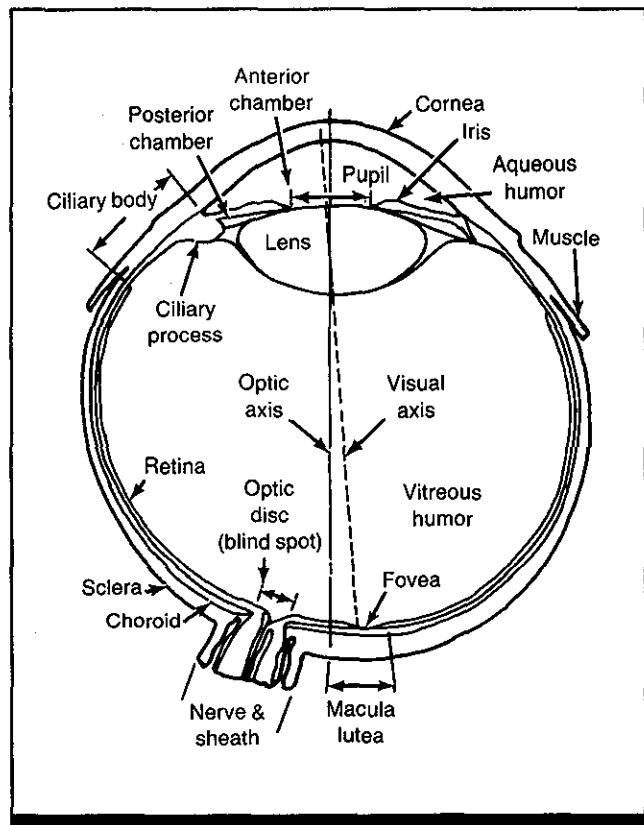

Figure 1. Horizontal section of the right human eye. (From Ref. 1)

epithelium and the blood vessels of the choroid coat reflect light of predominantly long wavelengths back to the receptors, reducing the amount of backscatter within the eye. All of the photoreceptors are ultimately connected to the *optic nerve*, which carries information about the image to the brain. The optic nerve joins the retina at the *optic disc*. There are no photoreceptors at this location, so it is known as the *blind spot*. The observer is aware of this blind spot only under special conditions, however.

For most purposes, it may be assumed that the retina is circularly organized around the *macula lutea*, a circular area covering 2-3 mm in diameter (equivalent to 5-10 deg of visual angle) and marked by yellow pigment. The macula includes the fovea, a central depression in which visual acuity is greatest. Covering only 1-2 deg arc, the fovea contains the eye's greatest concentration of cones, but no rods. Nerves and blood vessels skirt the fovea, allowing direct access of light to its receptors. Outside the fovea, rods are mixed with cones; the density of cones decreases rapidly with distance from the fovea, while the density of rods first increases, then decreases again at the extreme periphery of the retina.

Key References

1. Brown, J. L. (1966). The structure of the visual system. In C. H. Graham (Ed.), *Vision and visual perception* (pp. 39-59). New York: Wiley.
2. Riggs, L. A. (1971). Vision. In J. W. Kling & L. A. Riggs (Eds.), *Woodworth & Schlosberg's experimental psychology* (pp. 273-314). New York: Holt, Rinehart & Winston.
3. Salzmann, J. (1912). *The anatomy and physiology of the human eyeball in the normal state*. Chicago: University of Chicago Press.
4. Walls, G. L. (1942). *The vertebrate eye*. Bloomfield Hills, MI: Cranbrook Institute of Science.

Cross References

- 1.203 The eye as an optical instrument;
- 1.209 Visual optics;
- 1.210 Optical constants of the eye;
- 1.222 Visual accommodation;
- 1.301 Scotopic and photopic (rod and cone) vision

1.202 Transmissivity of the Ocular Media

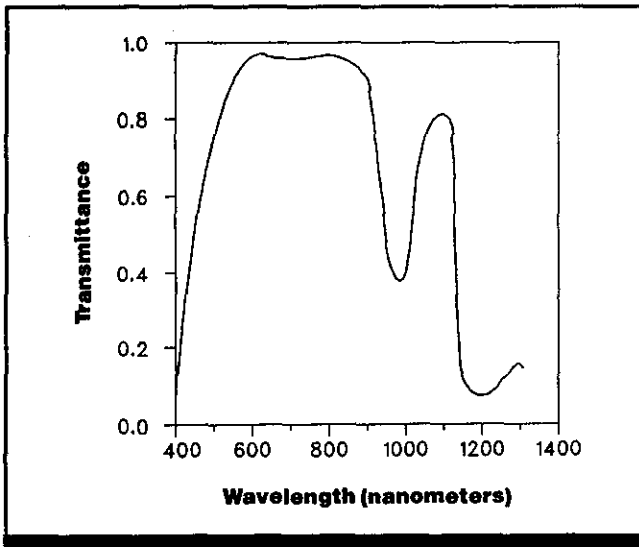

Figure 1. Best current estimates of the amount of light transmitted by the ocular media as a function of wavelength. (From Ref. 2)

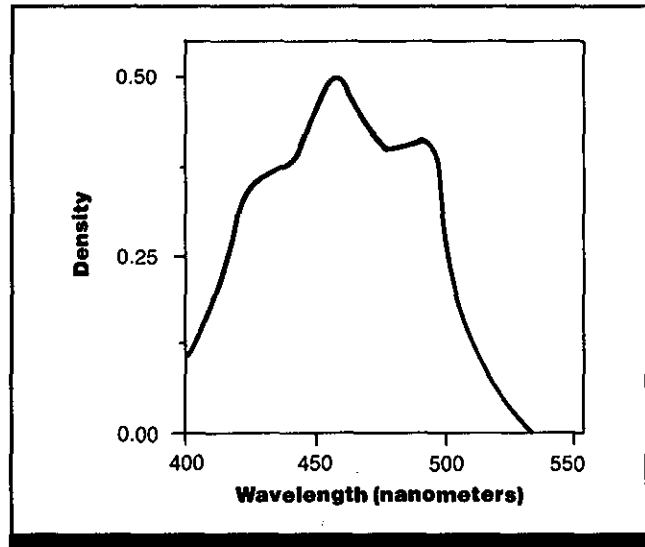

Figure 2. Density of the macular pigment as a function of wavelength. Light reaching the retina in the vicinity of the fovea is absorbed according to this curve. (From Ref. 6)

Key Terms

Macula lutea; ocular media; ocular transmissivity; spectral transmittance

General Description

In the eye, light must pass through several structures before reaching the layer of **photoreceptors**; consequently, light does not impinge on the photoreceptors in exactly the same state as it entered the eye. A large amount of light is scattered as it enters the eye and therefore does not reach the retina. Some light is absorbed by the **cornea**, **lens**, and **aqueous** and **vitreous humors**. More light is absorbed by the outer layers of the retina; light must pass through several layers of retina containing light-absorbing pigments before it reaches the layer containing the photoreceptors. Both the scattering and absorption of light vary with wavelength.

An observer's eye moves to center the image of interest on the **fovea**. The fovea itself is centered within the macula lutea, which covers an area approximately 5 deg in diameter. The macula contains a yellowish pigment that removes some of the light passing through to the photoreceptors. It absorbs different wavelengths at different rates, and thus

affects the sensitivity of the eye to different wavelengths. Energy losses within the eye must be considered when determining the amount of light actually stimulating the photoreceptors. Figure 1 shows the best current estimate of the transmissivity of the ocular media as a function of wavelength; this is an estimate of the total transmission of light to all of the retina. Because scattering is a function of wavelength, the light in the focal image will not have the same spectral composition as the light reaching the retina. Figure 2 shows the density of the macular pigment as a function of wavelength. Light reaching the retina in the macular region is absorbed according to this curve.

Table 1 provides estimates of the proportion of light that is transmitted to the photoreceptors in the fovea as a function of wavelength. Column 2 shows transmissivity of the ocular media, not including the macular absorption of light. Column 3 shows macular transmission. Column 4 gives the product of the first two columns as an estimate of total transmissivity to the photoreceptors.

Applications

It is necessary to know ocular light transmissivity to measure the distribution of light at the photoreceptors. Specification of how much light of a given wavelength is required

for a particular visual response also requires a measure of ocular transmissivity as a function of wavelength. Light absorption by the macula lutea causes differences in color matching between the fovea and the periphery of the retina.

Key References

- Boettner, E. A., & Wolter, J. R. (1962). Transmission of the ocular media. *Investigative Ophthalmology*, 1, 776-783.
- Ham, W. T., Mueller, H. A., & Ruffolo, J. J. (1980). Retinal effects of blue light exposure. *Society of Photo-optical Instrumentation and Engineering*, 229, 46-50.
- Ludvig, E., & McCarthy, E. F. (1938). Absorption of visible light by the refractive media of the human eye. *Archives of Ophthalmology*, 20, 37.
- Stevens, S. S. (1966). *Handbook of experimental psychology*. New York: Wiley.
- Wald, G. (1945). Human vision and the spectrum. *Science*, 101, 653.
- Wyszecki, G., & Stiles, W. S. (1982). *Color science* (2nd ed.). New York: Wiley.

Table 1. Spectral transmittance of ocular media. (From Ref. 4)

Wavelength (mm)	Spectral Transmittance of Cornea, Lens, and Aqueous and Vitreous Humors (Ref. 2)	Spectral Internal Transmittance of Macula Lutea (Ref. 4)	Spectral Transmittance of Ocular Media Including the Macula Lutea
360	0.052*	0.859	0.045
370	0.056*	0.826	0.046
380	0.062*	0.762	0.047
390	0.069*	0.695	0.048
400	0.086	0.577	0.050
410	0.106	0.506	0.054
420	0.160	0.396	0.063
430	0.248	0.316	0.078
440	0.318	0.305	0.097
450	0.388	0.212	0.082
460	0.426	0.206	0.088
470	0.438	0.299	0.131
480	0.458	0.250	0.115
490	0.481	0.263	0.126
500	0.495	0.516	0.256
510	0.510	0.798	0.407
520	0.525	0.935	0.491
530	0.543	0.968	0.526
540	0.559	0.977	0.546
550	0.566	0.985	0.557
560	0.572	0.989	0.566
570	0.583	0.989	0.577
580	0.594	0.989	0.587
590	0.602	0.989	0.595
600	0.610	1.000	0.603
610	0.619	1.000	0.619
620	0.631	1.000	0.631
630	0.641	1.000	0.641
640	0.649	1.000	0.649
650	0.657	1.000	0.657
660	0.664	1.000	0.664
670	0.676	1.000	0.676
680	0.690	1.000	0.690
690	0.698	1.000	0.698
700	0.705	1.000	0.705
710	0.707	1.000	0.707
720	0.708	1.000	0.708
730	0.710	1.000	0.710
740	0.711	1.000	0.711
750	0.713	1.000	0.713

Note: Column 4 is the product of Columns 2 and 3. The data in the table were obtained from direct measurement on the eyes of deceased persons.

* Extrapolated

Cross References

1.201 Anatomy of the human eye

1.203 The Eye as an Optical Instrument

Key Terms

Cornea; eye focus; lens; pupil; retinal image; visual image

General Description

The eye is a light-sensing device that supplies the observer with information about the external world. The optical system of the eye bends or refracts light rays from objects in space and forms real images of the objects on the **retina** at the back of the eyeball. The images formed by the eye are inverted and left-right reversed, as well as curved in conformity with the curvature of the retina. Figure 1 shows in simplified form the eye forming an image of a distant point object. The eye is sometimes compared with a camera in its ability to focus light on a photosensitive surface (see Table 1); however, it should be kept in mind that, while photographic film is a passive chemical system, the retina is an active and interactive system containing a complex network of interconnected neural structures.

The optical system of the eye is quite complex. Incoming light first strikes the *cornea*, the highly curved front surface of the eyeball. Behind the cornea is the *iris* of the eye (not shown in figure), at the center of which is the pupil opening.

Behind the pupil is the *crystalline lens*. The crystalline lens is an elastic, double-convex lens whose rear surface curves more sharply than its front surface. The crystalline lens is composed of layers of fibrous material and is harder in the center than toward the edges. The refractive index of the lens is greatest in the center and decreases toward the edges. The lens is surrounded by the *ciliary muscle*. Contraction of this muscle changes the curvature and thickness of the lens, thereby altering the total refractive power (focal length) of the eye.

Unlike the lens systems in most man-made optical instruments, the eye contains no air spaces. The front chamber between the cornea and the lens is filled with the *aqueous humor*, a weak salt solution. The larger chamber behind the lens is filled with *vitreous humor*, a thin, jelly-like substance. Both the aqueous and vitreous humors have an index of refraction of ~ 1.336 , close to that of water.

The cornea and the crystalline lens together provide the refractive or focusing power of the eye. The average human eye has a focal length of ~ 60 diopters (16.7 mm) when focused for distant objects and 69.4 diopters (14.4 mm) when focused for extremely close objects. Thus, eye focal length changes by ~ 17 percent in changing focus from distant to very close objects. At all distances, the cornea contributes 43.08 diopters (roughly two-thirds) of the eye's total refractive power. The focal length of the crystalline lens is shortest and its refractive power greatest for objects at very close

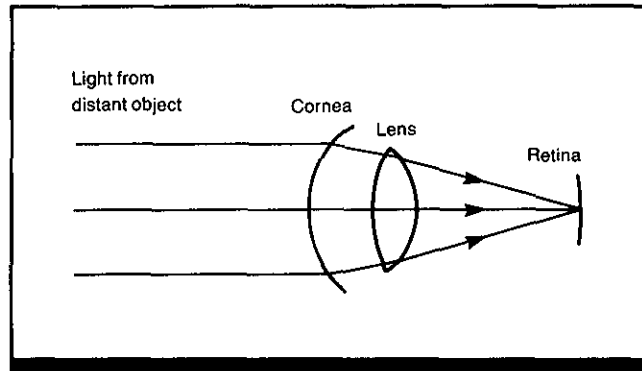

Figure 1. Schematic illustration of the formation on the retina of the image of a distant point source of light. (From Ref. 1)

distances. At near distances, the lens contributes ~ 38 percent of the total refractive power of the eye. The contribution of the lens is progressively less at longer distances.

The pupil of the eye varies in diameter from ~ 2 -8 mm and is largest at very low light levels. This size adjustment yields a range of variation in retinal illuminance of $\sim 16:1$. For far distances, where eye focal length is ~ 17 mm, this range of pupil diameters yields an optical system with an *f*/*v* value of *f*/2 to *f*/8 (where *f*/*v* value is the ratio of clear aperture to focal length).

The image formed on the retina by the optical system of the eye is not perfect. Because of the diffraction of light, as well as other physical and geometric optical factors, the image of a point of light formed on the retina by the optics of the eye is not in completely sharp focus, but is blurred somewhat (CRef. 1.214).

As with most lens systems, the eye shows substantial aberrations. The refractive power of the eye differs for different wavelengths. Thus, not all wavelengths of light can be in focus on the retina simultaneously; if the eye is in proper focus for one wavelength, other wavelengths will be blurred slightly. This is known as *chromatic aberration* (CRef. 1.212). With spherical lenses, light passing through the edges of the lens is brought to a shorter focus than light passing through the center of the lens, leading to degradation of the image (*spherical aberration*) (CRef. 1.211). As with most optical systems, spherical aberration in the eye is reduced by decreasing the pupil (aperture) size. When pupils are small (3-4 mm), spherical aberration has little effect upon visual acuity; however, when the pupil opens wider, as in dim light, spherical aberration can reduce visual resolution. For reasons that are not well understood, the eye's appreciable chromatic aberration does not reduce visual acuity.

Table 1. Comparison between camera and eye.

Parts and Functions	Camera	Eye
Image forming device	Lens	System of optical structures (primarily cornea and crystalline lens)
Focal length	Fixed*	Variable
Method of focus	Movement of lens	Alteration of focal length
Means of focus change	Operator or automatic	Automatic, unconscious control
Image surface	Flat	Highly curved
Image illuminance control	Diaphragm	Iris
Photosensitive element	Photographic film	Retinal receptors
Response control	Diaphragm, shutter	Iris, retinal adaptation
Sensitivity of photosensitive element	Fixed	Variable
Dynamic range of photosensitive element		
Instantaneous	Small	Large
Long-Term	Small	Extremely Large
Optical Aberrations	Small	Large
Space behind lens	Air	Fluid

*Not including zoom lenses

Constraints

- Comparison between eye and camera are simplifications for tutorial purposes.

Key References

1. Farrell, R. J., & Booth, J. M. (1984). *Design handbook for imagery interpretation equipment*. Seattle, WA: Boeing Aerospace Co.

2. Westheimer, G. (1972). Optical Properties of Vertebrate Eyes. In M. G. F. Fuortes, (Ed.), *Handbook of sensory physiology*. Vol. VII/2. *Physiology of photoreceptor organs*. Berlin: Springer-Verlag.

Cross References

1.201 Anatomy of the human eye;
1.206 Effect of lenses on the visual image;
1.209 Visual optics;

1.210 Optical constants of the eye;
1.211 Spherical aberration;
1.212 Axial chromatic aberration;
1.214 The point-spread function of the eye

1.204 Spherical Refractive Errors

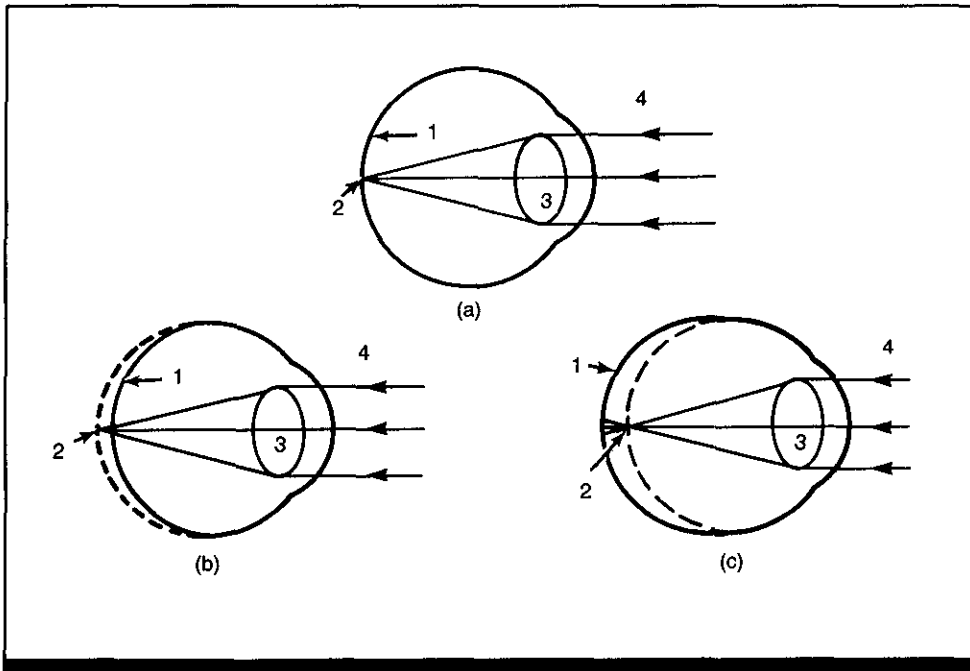

Figure 1. Refraction of light by the eye. (a) normal (emmetropic) eye; (b) farsighted (hyperopic) eye; (c) nearsighted (myopic) eye; (1 = retina; 2 = focal point; 3 = lens; 4 = incoming light). (From Ref. 3)

Key Terms

Ametropia; emmetropia; eye focus; farsightedness; focus defect; hyperopia; myopia; nearsightedness; refraction; retinal image; spherical refractive error; visual image

General Description

The curvature of the lens of the eye changes automatically in response to objects viewed at different distances, increasing or reducing the total refractive power of the eye so that the image of the object comes to a sharp focus on the retina.

In a person with normal refraction (known as an *emmetrope*), focus is adequate for all normal viewing distances. In some individuals, however, the shape of the eyeball prevents the lens from bringing the image into proper focus on the retina. In *nearsightedness* (myopia), the eyeball is elongated so that the image of a distant object comes into focus in front of the retina, and the image that falls on the retina itself is blurred (Fig. 1c). As the object is moved closer to the eye, the plane of focus moves nearer to the retina until, at some close distance, the image is in sharp focus on the retina. Thus, nearsighted persons can see only nearby objects sharply.

When the eyeball is too short for its refracting power (Fig. 1b), the image of a far object is brought into focus at a distance that would put it behind the retina, a condition known as farsightedness (hyperopia). Most young people who are farsighted are able to overcome this focus error by bulging the lenses to increase the eye's refractive power and bring the image into proper focus. As the lens stiffens with age, curvature cannot be changed enough to completely accommodate; farsighted people cannot see distant objects clearly as they get older. Stiffening of the lens also prevents appropriate adjustments of curvature when an object is moved closer, resulting in blurred images. For this reason, both farsighted people and those of normal vision need glasses for reading and viewing nearby objects when they grow older.

Both types of refractive error can be corrected with relatively simple (spherical) lenses.

Applications

Refractive error should be considered in the design of optical equipment; a range of focus adjustment and an eye clearance distance should be provided to accommodate operators who wear glasses.

Key References

1. Cornsweet, T. N. (1970). *Visual perception*. New York: Academic Press.

2. Davson, H. (in press). *The eye: Visual optics & optical space sense*. (Vol. 4, 2nd ed.). New York: Academic Press.

3. Wyburn, G. M., Pickford, R. W., & Hirst, R. J. (1964). In G. M. Wyburn (Ed.), *Human senses and perception*. London: Oliver & Boyd.

1.205 Astigmatism

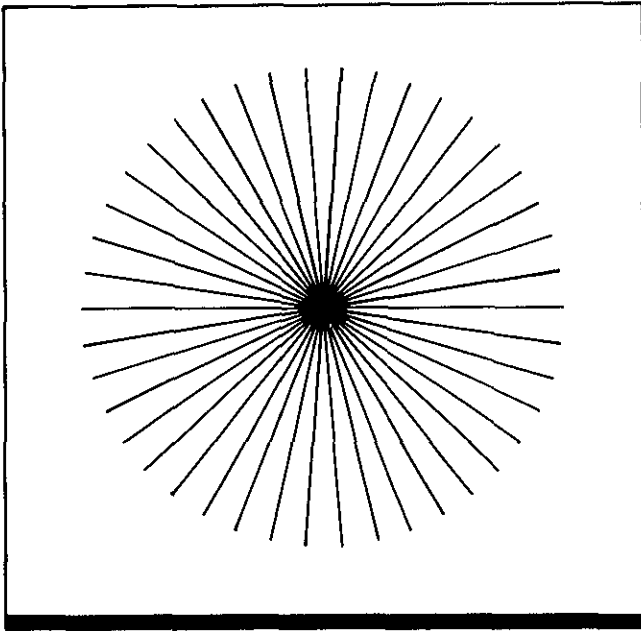

Figure 1. A ray pattern in which the variable appearance of rays demonstrates the effects of astigmatism. (From Ref. 1)

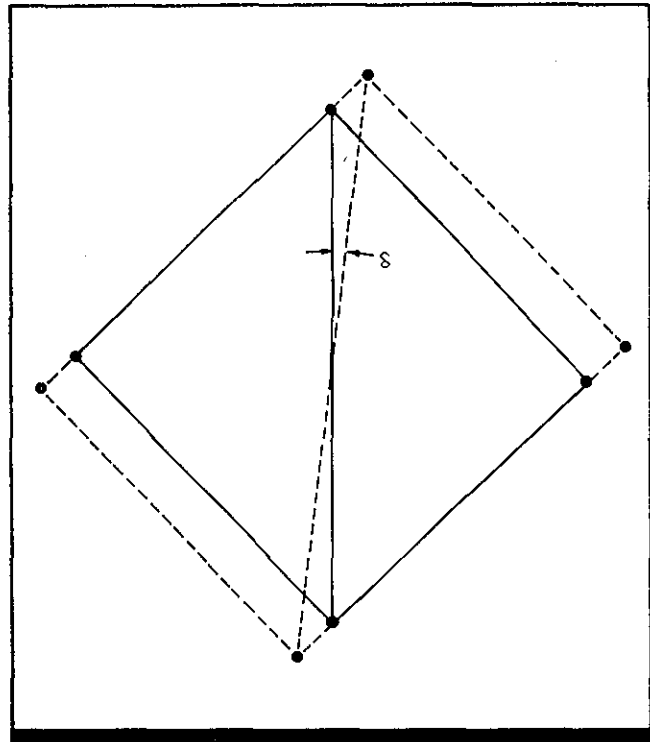

Figure 2. Inclination of the objective vertical by an oblique astigmatic lens. If an observer wearing a compound astigmatic lens views a square aligned with the principal axes of astigmatism, it will appear as a rectangle. A line in the frontoparallel plane that is not in one of the principal meridians will appear rotated through an angle δ , called the declination error. (From *Handbook of perception and human performance*)

Key Terms

Anisotopia; astigmatism; declination error; eye focus; refraction; retinal image; visual image

General Description

The optics of the typical human eye are *anisotropic*, that is, the optical power differs depending on orientation. A barrel-shaped distortion of the surface of the cornea (i.e., a cylindrical distortion of the normally spherical surface) produces the refractive error known as *astigmatism*. In astigmatism, a bar of light in, for example, a horizontal orientation would be brought to a different focus than a bar in a vertical orientation. Most human eyes have some degree of astigmatism.

Figure 1 contains a ray pattern that can demonstrate the effect of astigmatism. If one eye is fixated on the center of the pattern, some lines will probably appear darker and sharper than others. The dimmer lines are brought to a focus either in front of or behind the retina, due to greater or lesser optical power in that orientation.

In the normal eye, the image of a point source of light is not a point but a blur patch (CRef. 1.211). This blur patch is an ellipsoid in the astigmatic eye. If the point of light is brought to focus in front of the retina, the ellipsoid will have

a horizontal orientation and horizontal lines will be most sharply imaged. If the point of light would be brought to focus behind the retina (if the retina did not block the light), the ellipsoid would have a vertical orientation and vertical lines would be most sharply imaged.

Regular astigmatism can be characterized by the refractive state of two meridians at right angles. As shown in Fig. 2, a square aligned with these two meridians will be imaged as a rectangle. The length of the sides of the rectangle depends on the magnification of the eye in each of these meridians. When the magnification is m in one of the meridians and m' in the other, one side of the rectangle will be $(m' - m)$ times longer than the other. A diagonal drawn through the original square will still connect opposite corners of the rectangle but it will no longer make a 45 deg angle with the principal meridians. Instead, it will appear rotated through an angle with a tangent equal to m'/m . This is termed the declination error. Thus astigmatism changes the apparent orientation of lines that are not one of the principal meridians.

Applications

Astigmatism in an uncorrected, regular astigmat is generally measured by determining the refractive strength of the eye with a combination of an ordinary, spherical lens, and a cylindrical lens whose cylinder axis is oriented at an angle to the spherical lens (usually at a right angle). To specify the astigmatism, one usually states the spherical refractive error in one of the meridians, plus the difference in

refractive errors between the two meridians, specifying the orientation of the second meridian. The effects of an astigmatic lens can be specified similarly. This allows description of images on the retina and construction of corrective lenses whose cylindrical distortion counteracts that of the eye's optical system. Unlike spherical aberrations, for which the eye is equipped to correct, astigmatism can only be corrected with lenses.

Constraints

- Because of the declination error, when astigmatic spectacle corrections are unequal for the two eyes, serious distortions of binocular depth perception can result (CRef. 5.908).
- Astigmatism may vary with the amplitude of accommodation (eye focus).

Key References

1. Cornsweet, T. N. (1970). *Visual perception*. New York: Academic Press.
2. Kaufman, L. (1974). *Sight and mind*. New York: Oxford University Press.

Cross References

- 1.204 Spherical refractive errors;
- 1.211 Spherical aberration;
- 1.221 Image quality and depth of focus;

5.908 Retinal image disparity due to image rotation in one eye;
Handbook of perception and human performance, Ch. 4, Sect. 1.8

1.206 Effect of Lenses on the Visual Image

Key Terms

Lens; refraction; retinal image; visual image

General Description

Corrective lenses bring a blurred image into focus on the observer's retina by counteracting errors in the eye's optical system. A corrective lens, however, has an additional effect: to change the angle subtended by the object at the eye's entrance pupil, causing an observer to err in judgments of a target's location or size. For example, bifocal lenses cause difficulty when one walks on stairs, because a positive lens (i.e., the type used to correct hyperopia, or farsightedness) increases the apparent size (thus decreasing apparent distance) of an object by increasing the size of its retinal image. Similarly, a negative lens (used to correct myopia, or nearsightedness) decreases an object's apparent size and increases apparent distance. These effects occur only when the line of sight is not along the optical axis of the lens.

Figure 1 shows how an object at optical infinity, subtending a given angle θ , will, when viewed through a lens, actually subtend a different angle θ' , which would normally be associated with a larger object. Equations 1 and 2 specify the relative magnification of the image for targets at optical infinity and at some finite distance (in meters), respectively:

$$m = 1/(1 - hF) \quad (1)$$

$$m = L/[L(1 - hF) + h^2F] \quad (2)$$

where m (equal to θ'/θ , with the angles depicted in Fig. 1) is the change in the target's angular subtense, L is the distance of the target in front of the eye, h is the distance between the lens and the center of the entrance pupil of the eye (usually taken as 0.017 m), and F is the power of the lens in diopters (all distances are represented in meters). Thus, at optical infinity, a 6-diopter lens will cause a ~11% size change. For nearby targets, the distance to the object becomes critical. In addition, for close targets, the eye's natural lens adjusts to the distance to the target. At optical infinity, Eqs. 1 and 2 are equivalent.

These equations specify the size of the retinal image of an object seen through a lens compared to the size of the image when the object is not viewed through the lens. They are valid even in the presence of image blur because they are derived for chief rays (i.e., the center of the eye's entrance pupil is used as the reference point).

A target point situated on the optical axis of the lens will be seen in the original direction when viewed through the lens (provided the axis of the lens is aligned with the line of

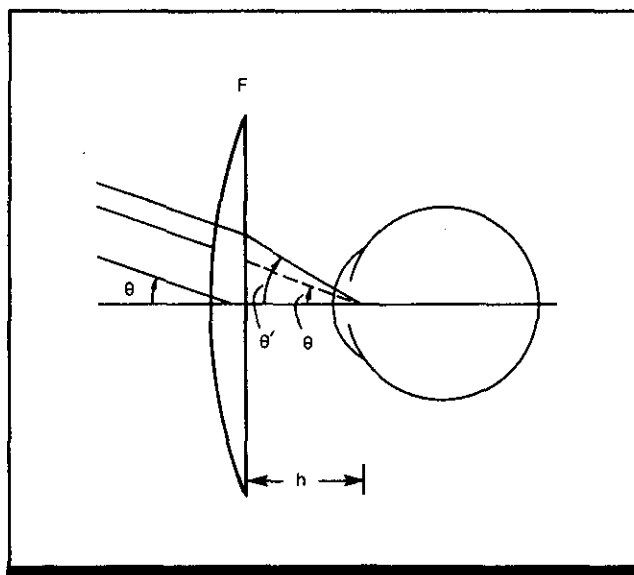

Figure 1. Path of light rays of a target at optical infinity. Without the lens, the image subtends angle θ . When viewed through a positive lens, the image subtends a larger angle θ' . This could lead to the interpretation that the target is larger than it actually is. The relationship between spectacle magnification ($m = \theta'/\theta$), lens power (F), and the distance between the lens and the eye (h) is given in Eq. 1. (From Ref. 1)

sight). Equations 1 and 2 can also be used to specify in angular units the location of object point that is not on the optical axis of the lens. Assume that a target point is located so that the line joining it to the center of the entrance pupil makes an angle θ with the optical axis of the lens. Then, when seen through the lens, the object will be at the angle $m\theta$.

The same equations can also be used to specify the angle through which the eye must be rotated in order to bring an object in the periphery of the visual field to the fovea of the eye. In this case, however, the center of rotation of the eye must be substituted for the eye entrance pupil to determine the value of h in the equations. The center of rotation of the eye is usually about 10 mm behind the entrance pupil. Because of this increase in h , the value of m is changed substantially. Thus, the effects of a lens are more prominent with respect to the change in the eye movements that must be made to fixate on an eccentric target.

Applications

When an observer wears corrective lenses, there may be some distortion of a target's apparent size or location. The problem can be acute when the observer needs to respond to a target that initially appears in the retinal periphery.

Constraints

- Other characteristics of lenses, such as spherical aberration (CRef. 1.211) and chromatic aberration (CRef. 1.212), must also be considered.
-

Key References

1. Westheimer, G. (1986). The eye as an optical instrument. In K. R. Boff, L. Kaufman, & J. P. Thomas

(Eds.), *Handbook of perception and human performance: Vol. 1. Sensory processes and perception*. New York: Wiley.

Cross References

1.201 Anatomy of the human eye;
1.203 The eye as an optical instrument;

1.211 Spherical aberration;
1.212 Axial chromatic aberration;
1.222 Visual accommodation

1.207 Eye Center of Rotation and Rotation Limits

Key Terms

Eye rotation; viewing comfort; vignetting

General Description

The center of rotation of the eye is located ~13 mm behind the front surface of the cornea (Ref. 2). For normal, unaided viewing, the comfort limit for eye rotation from straight ahead is ~40 deg; however, observers may avoid approaching this limit by rotating the head. When an optical aid such as a monocular telescope is used, head rotation is virtually eliminated, and consequently the size of the useful visual field may be at least partially determined by the comfort limit of rotation. The comfort limit for rotation for a monocular telescope with an apparent field of view of 85 deg is 30 deg. Before this limit is reached, light rays at certain angles of incidence will be prevented from entering the pupil (unless the exit pupil of the instrument is appreciably larger than the eye pupil); this condition is known as vignetting. Vignetting reduces retinal illuminance. Up to 55% vignetting generally goes unnoticed by observers.

Applications

Development of optical aids, especially when head movement of an observer using such a device is not possible.

Methods

- 13.5-mm exit pupil
- Telecentric scaling device to measure eye distances

Test Conditions

- Target was a color transparency, content not specified
- Monocular telescope, 85-deg apparent field of view, with

Experimental Procedure

- Independent variables: eye rotation (in degrees), incident ray angle

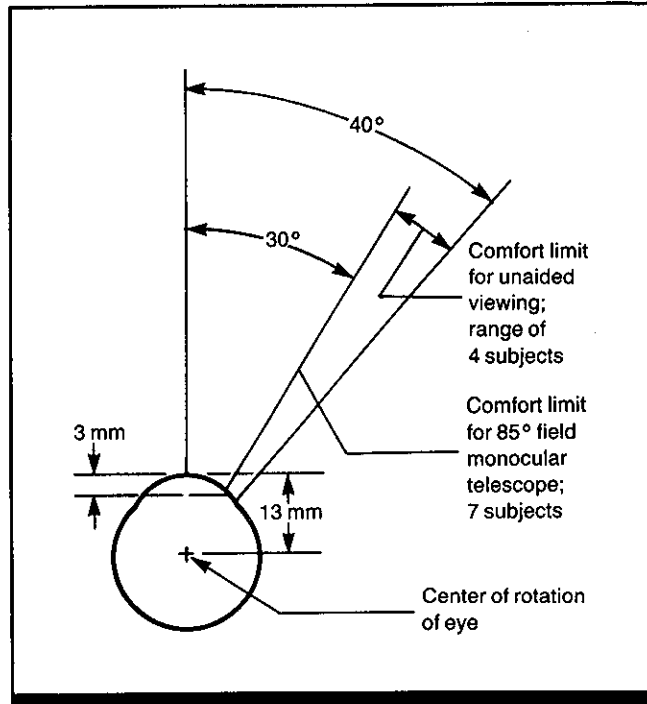

Figure 1. Comfort limits of eye rotation for unaided and aided viewing. (From Ref. 1)

- (in degrees), distance from corneal vertex to instrument pupil (in inches)
- Dependent variables: amount of vignetting, comfort of observer at various eye rotations
- Observer's task: not specified,

- but probably included verbal reports of amount of discomfort and perceived dimming of the image at various eye rotations
- 7 observers

Experimental Results

- With viewing through a monocular telescope, eye rotation >30 deg is uncomfortable but physically possible.
- The amount of vignetting is determined by both the incident angle of light ray and eye rotation. For example, for a ray originating at +30 deg, vignetting begins when the eye is rotated -11 deg and +25 deg; total extinction for the same ray occurs with eye rotations of -25 deg and +40 deg. The space between the two "beginning of vignetting" curves in Fig. 2 indicates an area of no vignetting. Total extinction indicates no light rays are entering the observer's pupil from that angle.

- Up to 55% vignetting on the outside of the field is unnoticed by observers; that is, such amounts of vignetting do not produce noticeable dimming of the image.
- In a related experiment with unaided viewing, the comfort limit of eye rotation is ~40 deg; beyond this, observers compensate with head rotation. Most observers make these movements automatically and without awareness of them.

Variability

No information on variability was given.

Constraints

Results described should be interpreted cautiously because of the limited amount of work in this area.

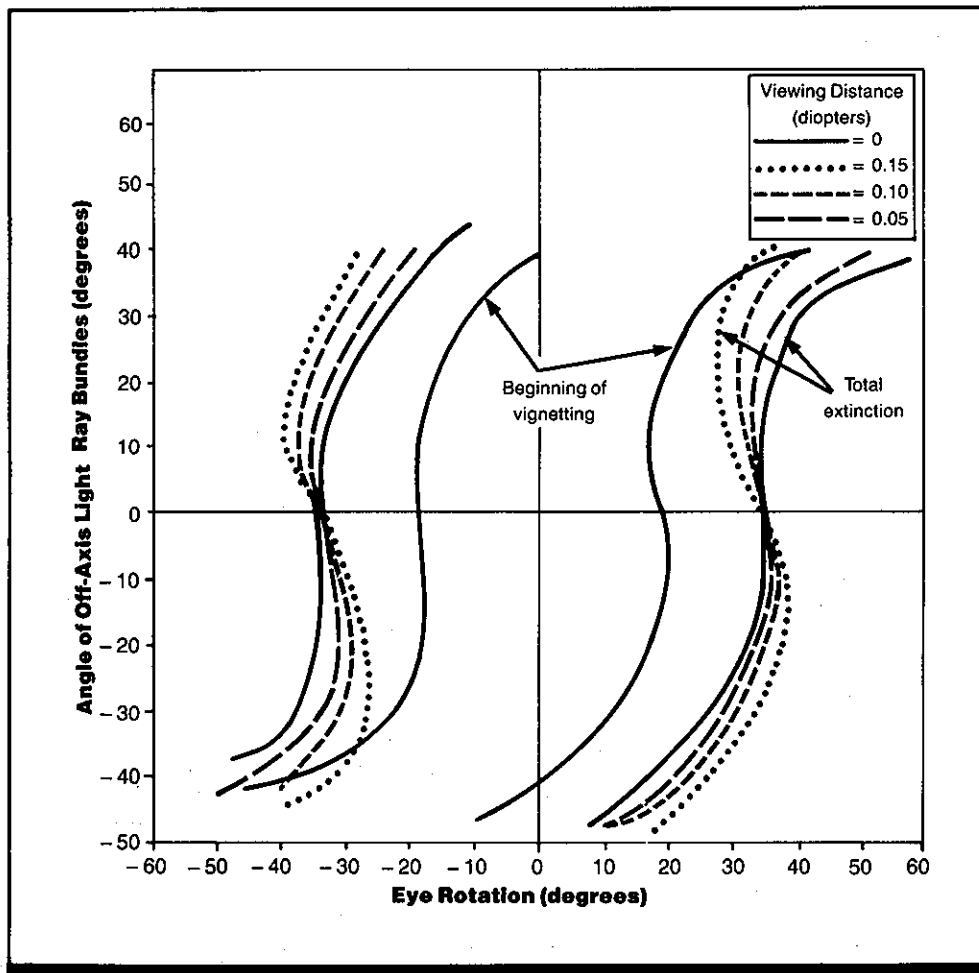

Figure 2. Vignetting as a function of eye rotation for varying angles of incidence of light rays and viewing distance. (Distance in diopters corresponds to the reciprocal of distance in meters.) (From Ref. 4)

Key References

*1. Farrell, R. J., & Booth, J. M. (1984). *Design handbook for imagery interpretation equipment*. Seattle, WA: Boeing Aerospace Co.

2. Fry, G. A. (1965). The eye and vision. In R. Kingslake (Ed.), *Applied optics and optical engineering, Vol. II*. New York: Academic Press.

3. Sanders, A. (1963). *The selective process in the functional visual field*. Soesterberg, The Netherlands: Institute for Perception, Dutch Institute for Applied Scientific Research.

4. Spiro, I. J. (1961). Eye location for a wide-field large-exit-pupil optical system. *Journal of the Optical Society of America*, *51*, 103-104.

Cross References

1.960 Factors affecting coordination of head rotation and eye movements

1.208 Interpupillary Distance

Key Terms

Binocular viewing; convergence; interpupillary distance

General Description

The structure of the human eye has been well documented; however, an individual's eyes may differ considerably from the "standard eye." One of the variable factors is interpupillary distance (IPD), the distance between the centers of the eyes' pupils. IPD ranges from 6-76 mm across individuals. This variability should be considered in the design and use of binocular viewing devices such as stereoscopes, microscopes, etc. Median IPD values measured differ considerably from one subject group to another (see Table 1). However, a range of 50-76 mm should be adequate for most applications.

When the eyes converge rather than look ahead in parallel (as an object approaches, for example), IPD decreases as the eye rotates about its center (see Fig. 1). The reduction (R) of IPD with convergence can be computed by the equation:

$$R = 20 \sin \theta/2,$$

where θ is the convergence angle. For small convergence angles, $R = 0.1745 \theta$ mm (where θ is in degrees). This formula applies to ocular convergence and also to instruments in which the eyepiece axes converge. This reduction in IPD has important implications. A precisely set IPD for an individual observer is essential to minimize erroneous depth effects (CRef. 5.934) when measuring color imagery with a stereo comparator, for example. The reduction in IPD with an eye convergence angle of 8 deg is ~ 1.4 mm. This means that eyes with a typical (median) IPD of 63.2 mm will have the IPD reduced to ~ 61.8 mm, about the 35th percentile for

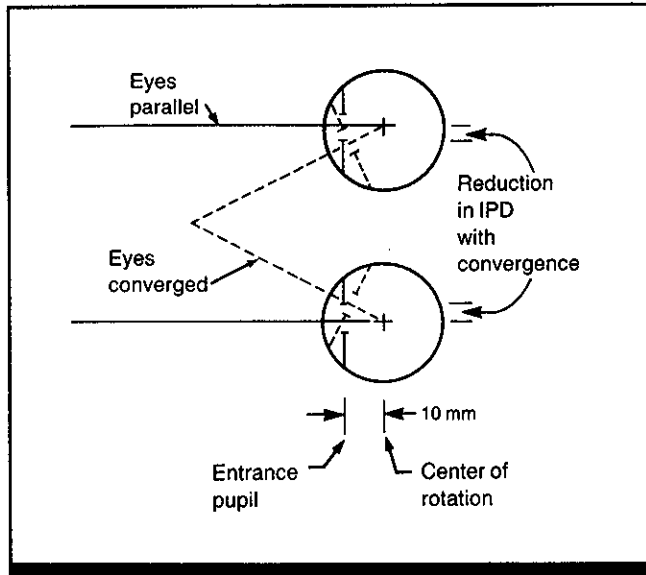

Figure 1. Reduction in interpupillary distance with convergence of the eyes. As the eyes converge, the pupils move toward the middle of the head, decreasing the distance between the pupils. (From Ref. 4)

Air Force flying personnel (Ref. 5).

In instrument design, a large eyepiece diameter may be desirable to obtain a large apparent field of view and appreciable eye relief. The distance between the eyepieces may have to be compromised between the need to accommodate small IPDs and the desire for large fields and eye relief. Instructions for adjusting the eyepiece should be clear and conspicuous, so that users will not damage equipment.

Key References

1. Damon, A., Stoudt, H. W., & McFarland, R. A. (1966). *The human body in equipment design*. Cambridge, MA: Harvard University Press.
2. Damon, A., Bleibtreu, H. K., Elliot, O., & Giles, E. (1962). Predicting somatotype from body

measurements. *American Journal of Physical Anthropology*, 20, 461-473.

3. Dreyfuss, H. (1967). *Human factors in design*. New York: Whitney Library of Design.
4. Farrell, R. J., & Booth, J. M. (1984). *Design handbook for imagery interpretation equipment*

(D180-19063-1). Seattle, WA: Boeing Aerospace Co.

5. Hertzberg, H. T. E., Daniels, G. S., & Churchill, E. (1954). *Anthropometry of flying personnel—1950* (WADC-TR-52-321). WPAFB, Ohio: Wright Air De-

velopment Center. (DTIC No. AD047953)

6. US Army. (1962). *Military standardization handbook. Optical design* (MIL-HDBK-141). (Army Contract No. DA-36-038-ORD-20690). Washington, DC: Department of Defense.

Cross References

- 1.808 Convergence angle;
5.934 Color stereopsis

Table 1. Interpupillary distance (in millimeters) for different groups, based on observations taken from military personnel in the Air Force, Army, and Marines.

Group	Number in Sample	Percentile Rank			SD	Ref.
		5	50	95		
Aviators	4057	57.7	53.2	69.6	3.6	5
Army drivers (white)	431	54.1	58.9	64.0	3.0	2
Army drivers (black)	79	57.9	62.0	71.1	3.8	2
Females*	NA	—	63.5	—	—	3
Army & Air Force (females)	3205	51.0	—	65.0	—	6
Image interpreters**	61	—	64.9	—	—	***

SD = standard deviation of measurement within the group

* The 2.5 and 97.5 percentiles were 53.3 and 71.1, respectively.

** The 2.5 and 97.5 percentiles were 58.4 and 71.4, respectively.

*** Data collected by military technicians on image interpreters in 1975; reported in Ref. 4.

1.209 Visual Optics

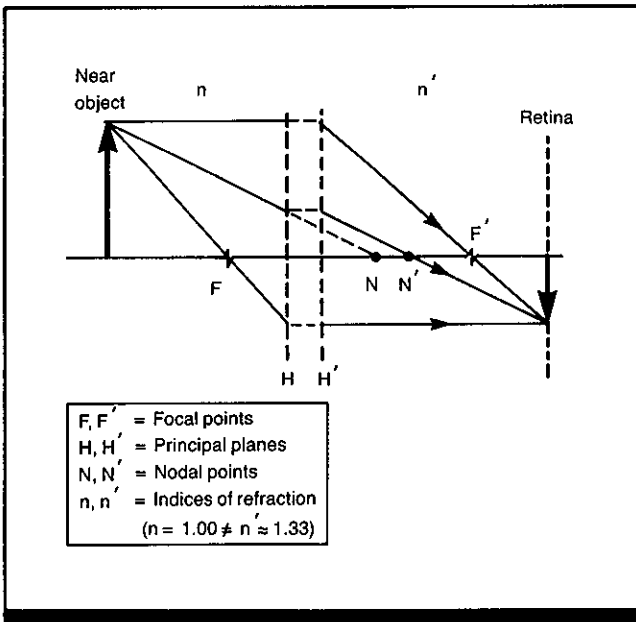

Figure 1. Schematic representation of the formation of an image of a nearby object by the eye. (From Ref. 3)

Key Terms

Entrance pupil; exit pupil; eye focus; lens; model eye; pupil; refraction; retinal image; schematic eye; visual image

General Description

The optical system of the eye is a positive lens system that forms real images (which are inverted and left-right reversed) on the retina at the back of the eye. The primary optical components of the eye are the cornea, which constitutes the highly curved front surface of the eye, and the crystalline lens immediately behind the pupil. Focusing to form sharp images on the retina is accomplished by automatic changes in the focal length of the lens, under involuntary muscular control (CRef. 1.222).

Since the optical elements of the eye have appreciable thickness, the optics constitute a thick lens with two principal points. Any ray of light entering through the first (front) principal point exits at the second (rear) principal point in a direction parallel to the entering direction and aiming toward the retina. Figure 1 shows in a schematic way the formation of an image on the retina. The optical system of the eye is bounded by two different media with different refractive indices: air in the front, and the jellylike vitreous humor, with a refractive index of 1.336, in the back. This causes the principal points to be displaced toward the cornea from the nodal points. It also causes the eye to have two unequal focal lengths, making it an unequifocal system. The principal points, not the nodal points, are used in measuring equivalent focal length and conjugate object-image distances in unequifocal systems.

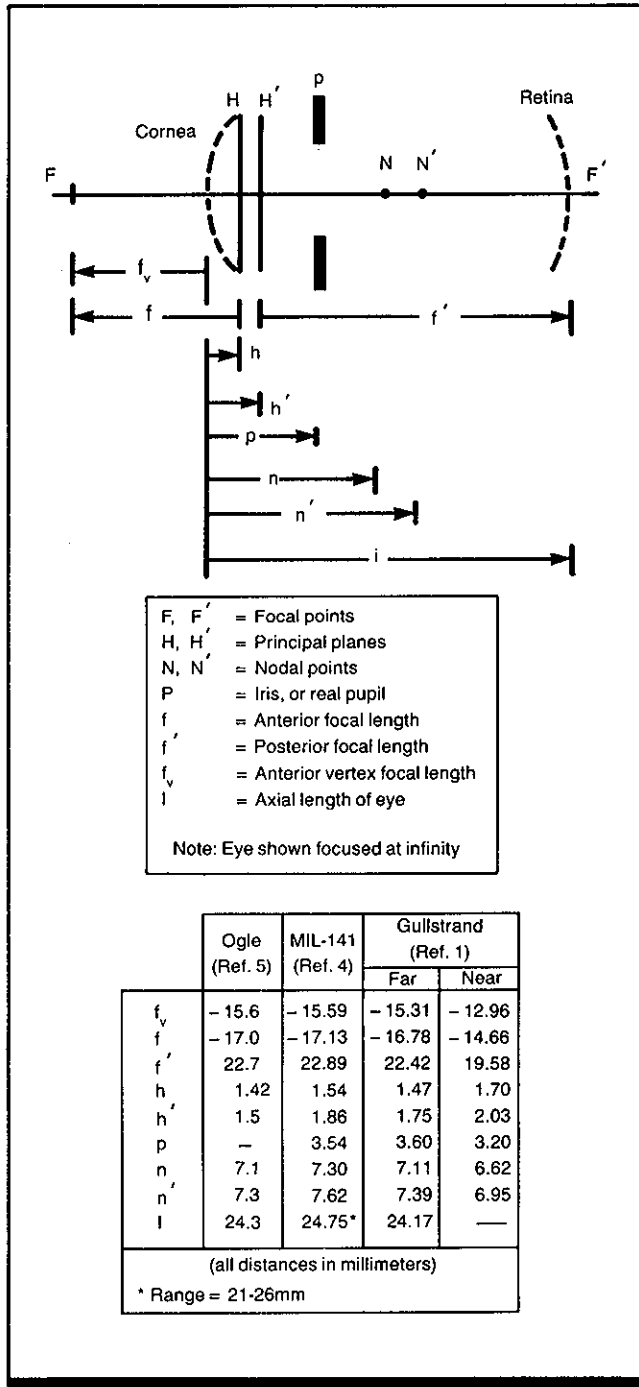

Figure 2. Parameters for three different schematic eyes: the Gullstrand No. 2 eye, the Ogle schematic eye, and the MIL-141 schematic eye. The Ogle and MIL-141 models are for unaccommodated or far vision (infinity); the Gullstrand eye provides values for two focus distances, infinity and a near distance of 8.6 diopters (11.6 cm). (From Ref. 3)

The Model or Schematic Eye

Due to the inhomogeneities of the eye and the asphericity of some surfaces, no system of spherical refracting surfaces can exactly represent the optics of the eye. However, to a first approximation, the optical system of the eye can be regarded as a series of spherical refracting surfaces whose centers of curvature lie on a straight line. The refractive indices, radii of curvature, thicknesses, and distances of these refractive surfaces determine retinal image formation.

While these parameters differ for individual eyes, sets of average values have been worked out that closely simulate the optical system of the human eye and are adequate for most purposes. Such a system constitutes a representational, schematic, or theoretical (model) eye. Three such models used frequently are those devised by Gullstrand (Ref. 1) and by Ogle (Ref. 4), and the schematic eye appearing in the Military Standardization Handbook (MIL-HDBK-141) (Ref. 4). The parameters for these schematic eyes are given in Fig. 2. (For more detailed version of the MIL-141 eye incorporating complete optical and anatomical specifications, CRef. 1.210.) The Gullstrand eye is one of the earlier versions and is the most commonly used. The model devised by Ogle was an attempt to update the schematic eye using more current data. Note that overall refractive power is different for the three model eyes, but all values are close to 17 mm (58.82 diopters) for the unaccommodated eye (far vision). Some common values in the literature are 58.95, 59.93, and 58.37 diopters, corresponding to focal lengths of 16.97, 17.05 and 17.13 mm, respectively.

Reduced Eye

For computational purposes, it is frequently convenient to use as a model a simplified or reduced eye in which a single hypothetical refracting surface is substituted for the several real refractive surfaces of the eye. This substitution is possible because the principal planes of the eye (H and H') are very close together (0.28 mm in the Gullstrand model eye accommodated for infinity). In the reduced eye, the single refracting surface is midway between the two principal planes, the center of curvature is midway between the two nodal points (N and N'), and the appropriate refractive index for the fluid behind the refracting surface is calculated. Two versions of reduced eyes are shown in Fig. 3. In the Emsley version (Ref. 2), the imaginary refracting surface is 1.67 mm behind the front surface of the cornea, and has a radius of 5.55 mm and a refracting power of +60 diopters (D). In the Ogle reduced model, the refracting surface is coincident with the cornea, the radius is 5.6 mm, and the refracting power is 58.8.

Entrance and Exit Pupils

Light is admitted into the eye through the *pupil*, a round aperture in the center of the *iris*. It is the *entrance pupil* of the eye, not the real (physical) pupil, however, which limits the bundle of rays that enters the eye. The entrance pupil of the eye is the image of the real pupil formed by the cornea. The entrance pupil is the pupil we see when looking into another person's eye. The entrance pupil is larger and closer to the cornea than the real pupil. The real pupil is 3.6 mm behind the front surface of the cornea, while the entrance pupil formed by corneal refraction is 3.05 mm from the cornea and 0.55 mm in front of the iris or real pupil for an eye focused to infinity. Because of corneal magnification, the en-

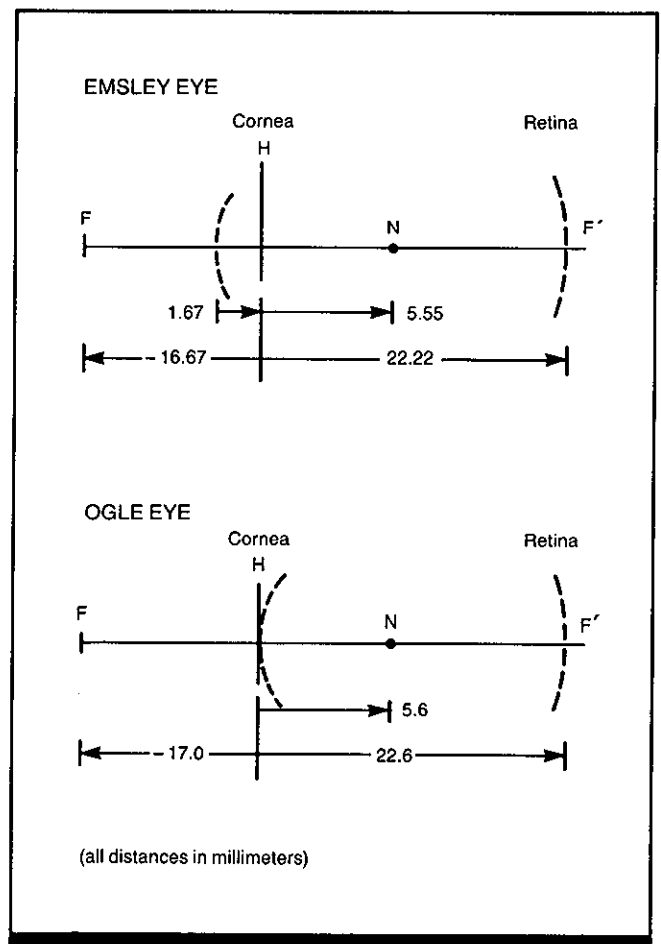

Figure 3. Parameters for two different reduced eyes; the Emsley 60-diopter eye (Ref. 8) and the Ogle 17-mm eye. F, F' focal points; $H =$ principal plane; $N =$ nodal point (Ref. 9). (From Ref. 3)

trance pupil is larger than the real pupil by a factor of 1.15. Knowing the location and size of the entrance pupil makes it unnecessary to trace light rays through the cornea and **aqueous humor** to see if the pupil admits them. To avoid light loss in instrument viewing, the entrance pupil of the eye should be placed at the exit pupil of instruments that have them.

The eye also has an *exit pupil*, which is the image of the real pupil formed by the crystalline lens when light is reflected back toward the outside of the **retina**. In the average eye, the exit pupil is 1.03 times as large as the real pupil and 0.08 mm behind it. The exit pupil is 3.68 mm behind the front surface of the cornea and 20.3 mm in front of the retina. The relative positions and sizes of the entrance and exit pupils are shown in Fig. 4.

Optical, Visual, and Pupillary Axes of the Eye

The *visual axis* of the eye is the line of regard or line of fixation connecting the midpoint of the visual field (or point being fixated) to the center of the **fovea**, the retinal region where acuity is highest. The *optical axis* of an optical system is the axis drawn through the centers of curvature of the optical surfaces of the elements comprising the system. In the eye, these are the front and back surfaces of the cornea and the front and back surfaces of the crystalline lens.

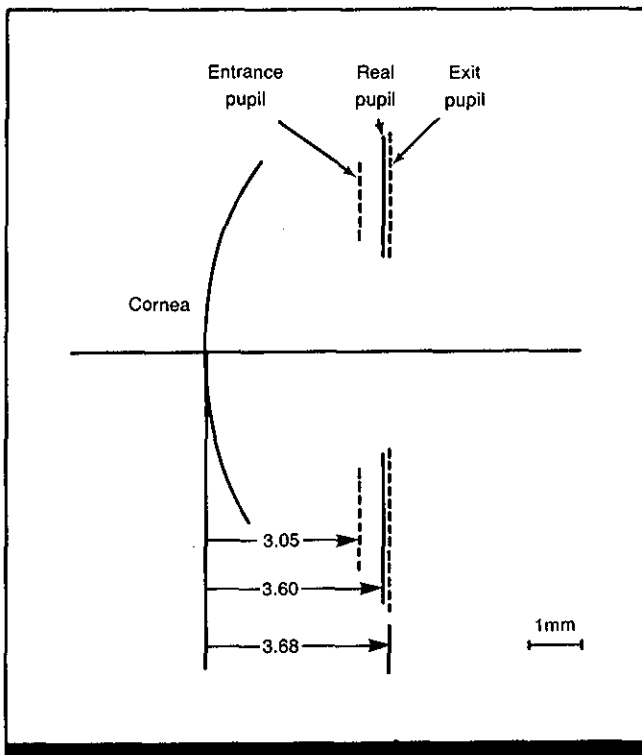

Figure 4. Relative positions and sizes of the real pupil, entrance pupil, and exit pupil of the eye. (From Ref. 1)

In real eyes, however, the centers of curvature of these surfaces do not fall on a common line; thus, the optical axis can only be estimated. In the typical eye, the optical and visual axes are separated by ~5 deg and cross within the crystalline lens. The eye is thus unique among optical instruments containing lenses in that maximum system resolution is not on the optical axis.

One estimate of the optical axis is the line perpendicular to the cornea and centered in the entrance pupil of the eye. The optical axis can also be found using a point source of light. One sights along the beam, while moving it around, until the reflections from all optical surfaces coincide. The *pupillary axis* is found by placing a point source in front of the eye and moving it around until the image of the light formed by reflection in the front surface of the cornea appears to lie in the center of the pupil.

The optical axis or the pupillary axis can be used to determine if an observer is accurately fixating a target, provided account is taken of the fact that the primary line of sight is about 5 deg away from the pupillary axis.

Because of the angle between the optical axis and the visual axis, objects of different colors appear to be at different distances. Thus, when red and green lights lie in the same plane, most observers see the red light as nearer.

This phenomenon is known as color stereopsis (CRef. 5.934). It is due to the fact that all light rays that do not enter the eye along the optic axis are deviated (bent) and different wavelengths of light are refracted or bent by differing amounts.

Applications

The optical parameters of the eye can be used to determine the size and location of the retinal image of an object. For example, the linear size, *i*, on the retina of the image of an object of length *L* viewed at a distance *U* from the first principal point of the eye can be determined using the universal lens equation

$$1/U + 1/V = 1/f, \tag{1}$$

where *V* is image distance from the second principal point and *f* is overall eye focal length. Image and object sizes are proportional to image and object distances, i.e., $i/L = V/U$, from which $V = U(i/L)$. Substituting for *V* in Eq. (1) and solving for *i* yields

$$i = Lf(U - f). \tag{2}$$

As an example, Eq. (2) can be used to find the retinal image size *i* of a meter stick ($L = 10^3$ mm) at a distance of 10 m ($U = 10^4$ mm). At 10 m, the eye is nearly unaccommodated, so that $f \approx 16.78$ mm. The equation yields $i = (10^3 \times 16.78)/(10^4 - 16.78) = 1.68$ mm. Thus, a meter stick viewed perpendicularly from 10 m has a retinal image length of ~1.7 mm. If the meter stick is inclined from perpendicular by angle *A*, image length is $i \cos A$.

Calculations can be made in **diopters (D)** using the standard conjugate equation

$$V = U + f$$

with all quantities measured in diopters and distances in front of the eye taken as negative by convention. Then, for the above example, $U = -10 \text{ m} = -0.1\text{D}$, and $f = 59.59\text{D}$, so that $V = -0.1\text{D} + 59.59\text{D} = 59.49\text{D}$. Transverse magnification, *m*, is

$$m = V/U,$$

thus $i = (V/U) = (-0.1/59.49)(10^3) = i = -1.68$ mm. (The minus sign indicates that the image is inverted relative to the object.)

Retinal image size may also be calculated from the angular subtense of the viewed object by assuming a value of 16.67 mm as the distance of the nodal point from the retina in the typical or normal eye. Thus, if *A* is the angular subtense of an object at the eye, its retinal image length is $16.67 \tan A$. In the example above, $\tan A = 1,000/10,000 = 0.1$, so that image length is $i = 16.67 \times 0.1 = 1.67$ mm. In making retinal image calculations, it must be kept in mind that *f* varies with viewing distance from a maximum of ~17 mm for focus to infinity to a minimum of ~14.4 mm for very near distances (~11 cm).

Constraints

- These models are for typical healthy **emmetropic** eyes (i.e., eyes with normal refraction). Any individual eye is likely to differ somewhat from these values.

Key References

*1. Bennett, A. G., & Francis, J. L. (1962). The eye as an optical system. In H. Davson (Ed.), *The eye, visual optics and the optical space sense* (pp. 101-108). New York: Academic Press.

2. Emsley, H. H. (1939). *Visual optics* (2nd ed.). London: Hatton Press.

*3. Farrell, R. J. & Booth, J. M. (1984). *Design handbook for imagery interpretation equipment*. Seattle, WA: Boeing Aerospace Co.

4. Hopkins, R. E. (1962). Visual optics. In *Optical Design* (MIL-HDBK-141). Washington, DC: Standardization Division, U. S. Defense Supply Agency.

5. Ogle, K. N. (1979). *Optics: An introduction for ophthalmologists*. Springfield, IL: C. C. Thomas.

6. Southall, J. P. C. (1937). *Intro-*

duction to physiological optics. New York: Dover.

7. Westheimer, G. (1972). Optical properties of vertebrate eyes. In M. G. F. Fuortes, (Ed.), *Handbook of sensory physiology: Vol. VIII/2. Physiology of photoreceptor organs*. Berlin: Springer.

Cross References

1.201 Anatomy of the human eye;
1.203 The eye as an optical instrument;

1.210 Optical constants of the eye;

1.222 Visual accommodation;

5.934 Color stereopsis

1.210 Optical Constants of the Eye

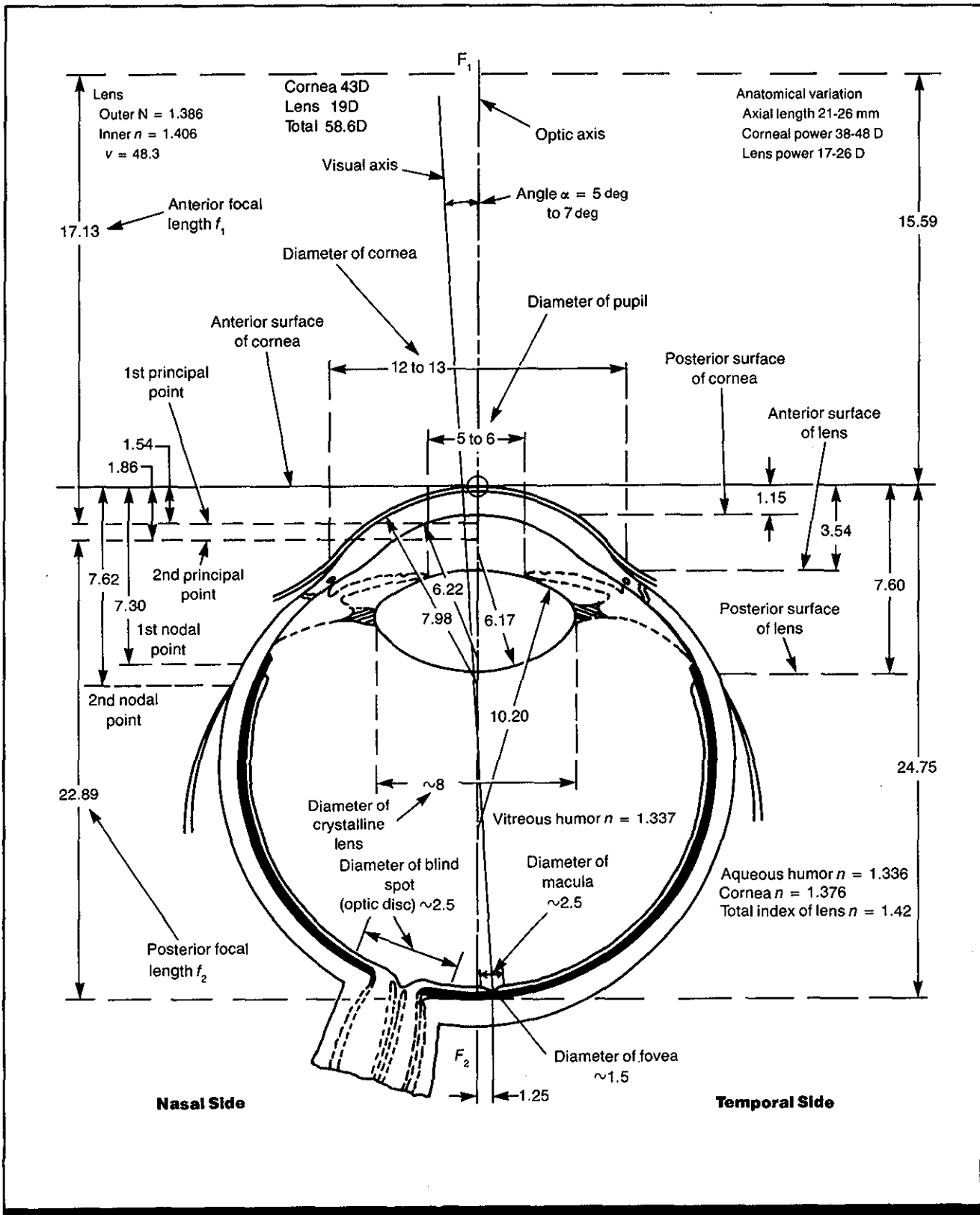

Figure 1. Optical constants for a standard eye. All dimensions are in millimeters unless otherwise noted. n = refractive index; D = diopter; V = vee number or Abbe constant; F_1, F_2 = first and second focal points. (From Ref. 2)

Key Terms

Aqueous humor; cornea; lens; model eye; optical constants; refraction; schematic eye; vitreous humor

General Description

The eye is a complex organic structure that, unlike most man-made optical devices, contains optical elements that are neither homogeneous nor spherical. For example, the crystalline lens is comprised of layers of organic material with varying indices of refraction, and its center is denser and more refractive than its periphery. The surfaces of the optical elements of the eye are not perfectly spherical but are somewhat flatter at the edges than at the center. The cornea and lens have optical axes that do not quite coincide, and the optical axis of the eye does not coincide with the visual axis (the line connecting the fovea to the point of fixation).

Despite this complexity, for practical purposes the eye can be regarded as having four major refracting surfaces: the front (anterior) and back (posterior) surfaces of the cornea, and the front and back surfaces of the lens. These surfaces may be regarded as spherical, with a common axis, and indices of refraction may be taken as constant within

any given optical element. The positions, radii of curvature, thicknesses, and indices of refraction of the optical elements are the optical constants of the eye. Their values determine the positions of the entrance and exit pupils of the eye, the principal points and nodal points of the eye's optics, and the retinal location and size of the *focused* images of objects. The values derived for these constants are approximations that yield an overall system similar in function to a real eye. Different investigators have obtained values that are slightly different, but no one set of values is clearly more valid than the others. Figure 1 shows the optical constants of a standard eye that is sometimes used in optical design. Table 1 provides a set of optical parameters or constants that is also used for computations and ray tracing. The values in Fig. 1 and Table 1 are not the same, but will yield similar results. (For an abbreviated version of the standard eye schematizing the most important optical properties for practical uses, as well as similar model eyes developed by other sources, CRef. 1.209.)

Constraints

- The optical constants of the eye are approximations based on simplifying assumptions, but are adequate for most purposes. They are for an average or typical **emmetropic** eye (i.e., eye with normal refraction).

Key References

1. Bennett, A. G., & Frances, J. L. (1962). The eye as an optical system. In H. Davson (Ed.), *The eye: Vol. 4. Visual optics and the optical space sense* (pp. 101-131). New York: Academic Press.

*2. Hopkins, R. E. (1962). Visual optics. In *Optical design* (MIL-HDBK-141). Washington DC: Standardization Division, U.S. Defense Supply Agency.

3. Westheimer, G. (1968). The eye. In Vernon B. Mountcastle (Ed.), *Medical physiology* (12th ed., pp. 1532-1553). St. Louis: C. V. Mosby.

4. Westheimer, G. (1972). Optical properties of vertebrate eyes. In M. G. F. Fuortes (Ed.), *Handbook of sensory physiology: Vol VIII/2. Physiology of photoreceptor organs*. Berlin: Springer-Verlag.

Cross References

- 1.201 Anatomy of the human eye;
1.203 The eye as an optical instrument;
1.209 Visual optics

Table 1. Optical parameters of a normal human eye (From Ref. 3)

Surface	Radius of curvature (mm)	Refractive Index	Distance from anterior surface of cornea (mm)	Refractive power (Diopters)
Cornea		1.376		
Anterior	7.8		—	+48.2
Posterior	6.8		0.5	-5.9
Aqueous humor		1.336		
Lens		1.386**		
Anterior	10.0*		3.6*	+5.0
Posterior	-6.0		7.2	+8.3
Vitreous humor		1.336		
Retina			24.0	

*During maximum **accommodation** the anterior surface of the lens has a radius of curvature of 5 mm and its anterior surface is moved forward to be nearly 3 mm behind the anterior surface of the cornea. Partial accommodation will produce values between these values and those given in the table.

**The index of refraction of the lens varies from 1.386 near each surface to 1.406 in the center. The indicated refractive power is for the lens surfaces only. The gradient of refractive index within the lens produces additional refractive power.

Note: The refractive index of air is 1.00.

1.211 Spherical Aberration

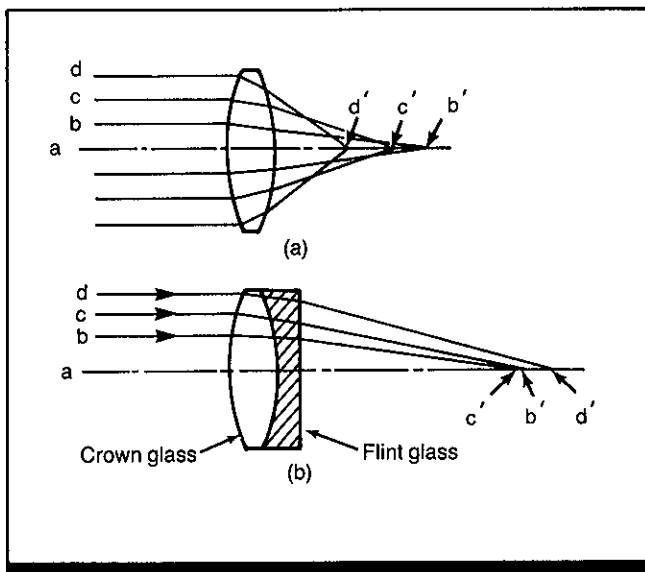

Figure 1. (a) Spherical aberration in a simple lens; light rays entering the edge of the lens are brought to a shorter focus than those entering the center of the lens. Because rays are not refracted to fall on a single point, the image will be blurred. (b) Two-element achromatic lens that partially corrects for spherical aberration. (From C. H. Graham [Ed.], *Vision and visual perception*. Copyright © 1966 by John Wiley & Sons. Reprinted with permission.)

Key Terms

Blur patch; eye focus; refraction; retinal image; spherical aberration; visual image

General Description

An ideal lens would refract light rays so that they converge to a single focal point on the other side of the lens. For a lens of a given material, an ideal shape can be found so that light of a given wavelength from a point source at a given distance will be refracted in this way. If the wavelength, distance, or lens material changes, a different shape is required for the ideal lens.

Spherical structures are reasonably close to ideal lenses. However, as they are not perfect, not all light rays from a point source will converge on precisely the same point; the rays striking the outer part of the lens are brought to a shorter focus than the inner rays (Fig. 1). The image thus formed will be a blur patch rather than a sharp point. This degradation of the image caused by spherical surfaces is known as *spherical aberration*. Spherical aberration can be overcome somewhat by using lenses comprised of elements with different indices of refraction.

In the human eye, none of the optical surfaces is perfectly spherical, and refractive power at the edges of these surfaces differs from refractive power at the center. In addition, the refractive power of the lens is greater at the center of the lens than at its edges. Because of this, for most people the light rays from a point source do not meet at a perfect point, rather the image is somewhat blurred. This degradation of the image is also called, somewhat imprecisely, spherical aberration. The amount of image blur is directly related to the size of the pupil. A small pupil minimizes the effects of spherical aberration by limiting light to the central portion of the cornea and lens where refractive power is more uniform. For the normal eye, spherical aberration probably does not have an important influence on visual acuity at moderate to high light intensity levels, since pupil size is small. When luminance is low and the pupil is large, spherical aberration may produce significant blurring.

Applications

Discrimination of relatively sharp images from blurred images may serve as a distance cue. Reference 1 found that reducing the spherical aberration of the eye reduces the accuracy of subject's accommodation (eye focus) in **monochromatic** light. Using an annular pupil that blocked out

rays through the center of the pupil, allowing only rays through the peripheral part of the lens to impinge on the retina, subjects adjusted a test target, viewed through a lens, from an out-of-focus position to the position of sharpest focus. Subjects' errors suggest that spherical aberration is used to determine the direction of focus errors.

Key References

1. Campbell, F. W., & Westheimer, G. (1959). Factors involving accommodation response of the human eye. *Journal of the Optical Society of America*, 49, 568-571.

2. Cornsweet, T. N. (1970). *Visual perception*. New York: Academic Press.

*3. Graham, C. H. (Ed.), (1966). *Vision and visual perception*. New York: Wiley.

Cross References

1.204 Spherical refractive errors;

1.205 Astigmatism;

1.209 Visual optics;

1.210 Optical constants of the eye;

1.214 The point-spread function of the eye;

1.221 Image quality and depth of focus

1.212 Axial Chromatic Aberration

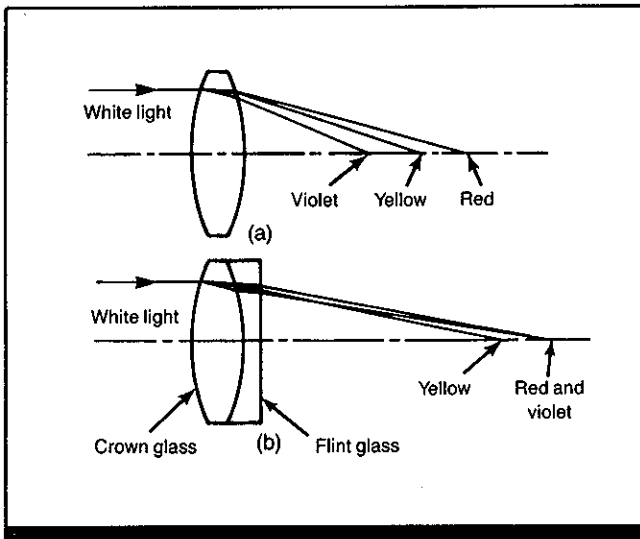

Figure 1. (a) Chromatic aberration in a simple lens; light of different wavelengths is brought to a focus at different distances from the lens; (b) achromatic lens partially correcting chromatic aberration. (From Ref. 4)

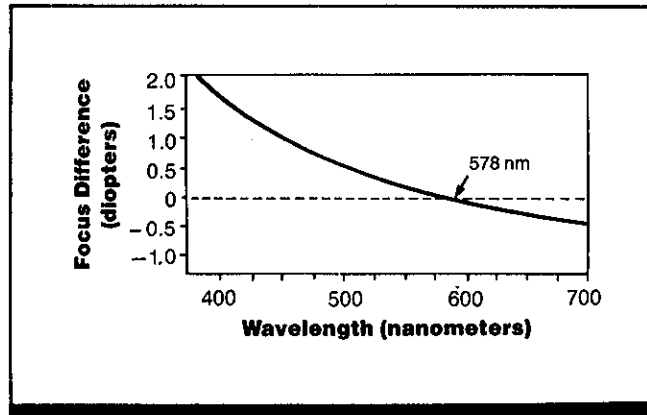

Figure 2. Axial chromatic aberration of the human eye. The graph shows the expected focus shift in going from a monochromatic 578-nm reference target to a monochromatic target of the indicated wavelength. (Plotted from data in Ref. 1)

Key Terms

Axial chromatic aberration; axial chromatism; eye focus; lens; longitudinal chromatism; retinal image; visual image

General Description

Variation in the focal length of an optical device with differences in the wavelength of light is called axial chromatic aberration (also known as axial chromatism or longitudinal chromatism). All optical devices that form images by refracting (bending) light have some degree of axial chromatic aberration because all such devices are made of materials whose light-bending properties vary with wavelength.

Understanding the cause of this type of aberration in optical systems requires examination of the refraction of light. Light of all wavelengths travels at the same speed in a vacuum. In any other transmitting medium (e.g., water), light at each wavelength travels at a different speed. Because of the difference in speed through different materials, light striking the surface of an optical material at any angle other than 90 deg (head-on) to the surface is bent or refracted at the surface or interface. The ratio of speed in a vacuum to speed in an optical medium (for a given wavelength) is the index of refraction of the medium for that wavelength. The index of refraction for optical materials increases as wavelength decreases. That is, as wavelength becomes shorter, the speed in the material decreases and the light is bent more upon entering or leaving; consequently, the index of refraction is higher.

An example of differential refraction with wavelength is provided by raindrops illuminated by sunlight. In this case, reflections and the differential refraction (bending) produce

a spread of colors that form the familiar rainbow. Prisms produce a spread or spectrum of colors in a similar way.

In optical instruments, chromatic aberration can be minimized by constructing lenses of two or more optical elements with different indices of refraction to compensate for differential bending with wavelength. However, even the most highly color-corrected lenses have focal lengths that are the same for only a few selected wavelengths. Some lenses, called achromats, are corrected so that their focal length is the same for two selected wavelengths; apochromat lenses have matched focal lengths for three selected wavelengths.

The optics of the eye contain curved transparent elements that refract light; like all refractive systems, the eye shows axial achromatic aberration. As illustrated in Fig. 2, the focal length of the eye increases with wavelength, so that no two wavelengths are brought to a focus at the same distance from the **cornea** (the primary refractive structure of the eye). The eye's optics behave as if they were composed of water; for example, the focal length of blue light is less than the focal length of red light. It is clear from the figure that the eye has pronounced axial chromatic aberration. An object that reflects only blue light can be focused when closer to the eye than can an object that reflects only red light. Using the wavelength of maximum **photopic luminosity** as a reference (which is a yellow-green near the middle of the visible spectrum), the figure shows that the eye is **myopic (nearsighted)** for shorter wavelengths and hyper-

opic (**farsighted**) for longer wavelengths. Because images of all wavelengths but one are out of focus for any one **accommodation** (focus) distance, one may hypothesize that visual resolution of the fine details of objects would be affected. Special multi-element lenses have been made to correct the axial chromatic aberration of the eye (Ref. 5). Somewhat surprisingly, visual acuity tests using such lenses have found that visual acuity is hardly changed (Ref. 1). Clearly, the eye's appreciable axial chromatic aberration has little influence on visual acuity. Why the loss in acuity from the color aberration is so low is unknown.

The axial chromatic aberration of the eye is easily demonstrated by viewing a point white light source through a filter that transmits only the red and violet extremes of the visual spectrum (e.g., a cobalt glass filter). When accommodation is correct for red light, a red point is seen in the center of a violet disc (the violet disc is the out-of-focus violet image of the point source). Conversely, when focus is correct for violet, a violet point is seen on a red disc. It is impossible to focus both wavelengths at the same time. The size of the out-of-focus disc is larger for larger pupil diameters.

Applications

Designing optical devices to correct for the eye's axial chromatic aberration is not worthwhile. When the eye is accommodated (focused) for a certain distance, a point object nearer or further than that distance will be brought to a focus behind or in front of the **retina**, respectively, and the image of the point on the retina will be a blur circle rather than a true point. Because the eye has a shorter focal length for

blue than for red light, objects further than **fixation** (focus) **distance** will give rise to a blur circle with a blue fringe and a red center, while objects nearer than fixation will produce a blur circle with a red fringe and a blue center. There is some evidence that this ordering of colors in the blur circle may be used as a depth cue in signaling whether an object is nearer or further than the **plane of fixation** (Ref. 2).

Constraints

- The magnitude of axial chromatic aberration decreases as pupil size decreases.

Key References

*1. Bedford, R. E., & Wyszecki, G. (1957). Axial chromatic aberration of the human eye. *Journal of the Optical Society of America*, 47, 564.

2. Campbell, F. W., & Westheimer, G. (1959). Factors influenc-

ing accommodation responses in the human eye. *Journal of the Optical Society of America*, 45, 579-594.

3. Cornsweet, T. N. (1970). *Visual perception*. New York: Academic Press.

*4. Graham, C. H. (Ed.) (1965). *Vision and visual perception*. New York: Wiley.

5. Luria, S. M., & Schwartz, I. (1960). *Visual acuity under red vs white illumination*. (V-19-1326). New London, CT: U.S. Naval Medical Research Laboratory. (DTIC #AD-234101)

6. Wyburn, G. M., Pickford, G. W., & Hirst, R. J. (1964). *Human senses and perception*. London: Oliver & Boyd, Ltd.

1.213 Diffraction of Light in Optical Systems

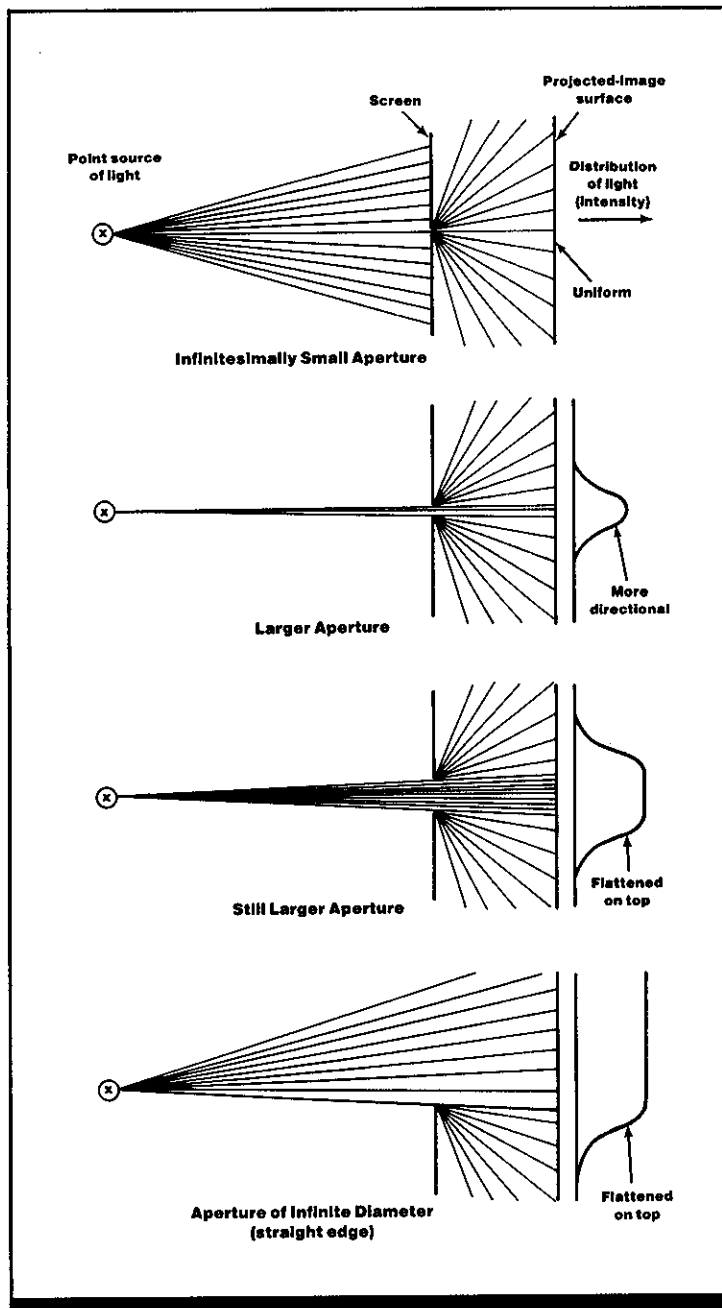

Figure 1. Diffraction of light by an aperture. (Not drawn to scale; light actually spreads over a much smaller angle.) (From Ref. 1)

Key Terms

Airy's disk; diffraction; eye focus; Fraunhofer diffraction pattern; light scatter; point-spread function; visual acuity

General Description

When light from a point source passes through an aperture, it is spread or diffracted so that the image of the point source on a surface behind the aperture is not a point but rather a distribution of light which varies with aperture size and shape as well as with wavelength, as shown in Fig. 1. The

point-spread function (Table 1) describes the distribution of light in the image of a diffracted point source. The intensity (I) of light at a given location in the image of the point source is a function of distance from the geometrical point image (ρ for circular apertures or α for rectangular openings), the diameter of the entrance pupil (a) in the meridian

under consideration, and the wavelength of the light (λ). Figure 2 is a graphic portrayal of Eq. 1, the light distribution of the image of a point source for an optical system with a round aperture.

Airy's Disk is the name given to the area bounded by the first zero cross points in the light distribution. The size of Airy's Disk varies with aperture size. The eye acts as a diffraction-limited device when the diameter of the entrance pupil of the eye is less than 2-2.5 mm. Table 2 shows how the diameter of Airy's Disk decreases as pupil diameter increases up to this value.

Applications

Under certain limiting conditions, the radius of Airy's Disk may serve as an indication of the smallest angle of resolution of the eye as an optical system (i.e., the distance by which two points of light must be separated to be seen as two points rather than a single point).

Constraints

- In the human eye, other factors in addition to diffraction, are responsible for the spread of light in the retinal image of a point source. Actual light spread is usually wider than the distribution described by Eqs. 1 and 2, especially with larger pupil openings (CRefs. 1.214, 1.215).

Key References

- *1. Cornsweet, T. N. (1970). *Visual perception*. New York: Academic Press.
- *2. Westheimer, G. (1986). The eye as an optical instrument. In

K. R. Boff, L. Kaufman, & J. P. Thomas (Eds.), *Handbook of perception and human performance: Vol. 1. Sensory processes and perception*. New York: Wiley.

Cross References

- 1.214 The point-spread function of the eye;
- 1.215 The line-spread function of the eye;
- 1.217 Retinal light distribution for an extended source

Table 2. Relationship between the diameter of the entrance pupil of the eye and the radius of Airy's disk for light of wavelength 555 nm. (From Ref. 2)

Diameter of Entrance Pupil (mm)	Radius of Airy's Disk (min arc)
0.5	4.66
1	2.33
1.5	1.56
2	1.16
2.5	0.94

Note: Airy's disk is the central path of the Fraunhofer diffraction pattern for a circular pupil (see Fig. 2). Beyond 2-2.5-mm pupil diameter, the eye no longer acts as a diffraction-limited device, and the actual retinal point-spread function does not become proportionally smaller as would be the case if only diffraction were involved.

Table 1. Equations for calculating light diffraction patterns for circular and rectangular apertures.

$$\text{For circular aperture: } I(\rho) = \left[\frac{J_1(\pi a \rho / \lambda)}{\pi a \rho / \lambda} \right]^2 \quad (1)$$

$$\text{For rectangular aperture: } I(\alpha) = \left[\frac{\sin(2\pi a \alpha / \lambda)}{2\pi a \alpha / \lambda} \right]^2 \quad (2)$$

I = intensity of light in the image
 ρ = radial distance from the geometrical point image, in radians of visual angle
 α = distance from the geometrical point image in radians of visual angle
 a = entrance pupil diameter, measured in linear units such as meters
 λ = wavelength of light, expressed in the same units as entrance pupil diameter
 J_1 = first-order Bessel function
 Note: Both α and a must be measured in the same meridian, which must be a principal meridian of the rectangular opening. Fig. 2 shows the pattern of light distribution corresponding to Eq. 1.

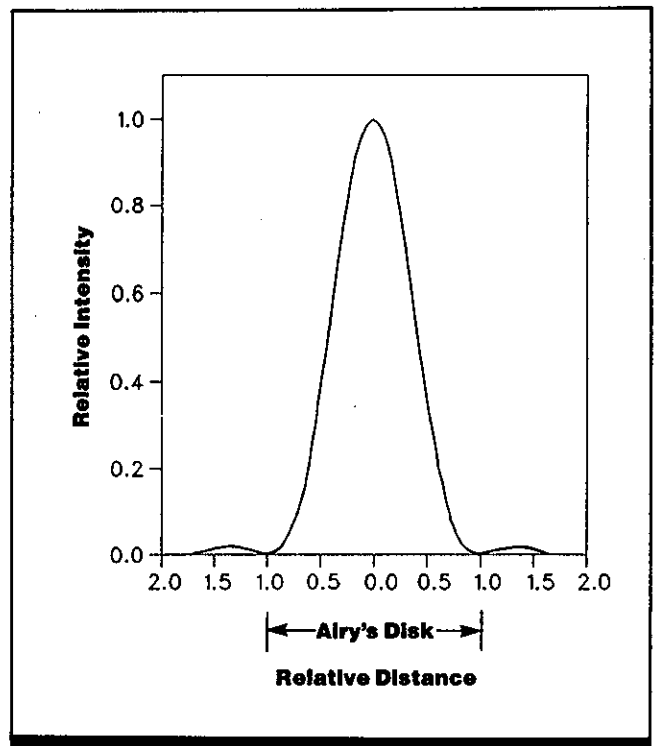

Figure 2. Distribution of light in the image of a point source for an optical system with a round pupil. The figure plots the light distribution given by Eq. 1, known as the Fraunhofer diffraction pattern. (From Ref. 2)

1.214 The Point-Spread Function of the Eye

Key Terms

Diffraction; eye focus; image intensity distribution; light scatter; line-spread function; point-spread function; retinal image; visual acuity; visual image

General Description

Several physical and geometric optical factors prevent a point source of light from being imaged as a point on the retina of the eye; rather, the image of a point source on the retina is a bell-shaped distribution of light with a series of colored fringes. The *point-spread function* describes this distribution (Fig. 1; Table 1). The spread of light can be calculated for an eye in good focus by Eq. 1, which is an empirical expression for the curve shown in Fig. 1:

$$Q(\rho) = 0.952 \exp(-2.59|\rho|^{1.36}) + 0.048 \exp(-2.43|\rho|^{1.74}) \quad (1)$$

where ρ is the distance from the center of the geometric image in minutes of arc of visual angle and $Q(\rho)$ is the intensity of the light in the image at distance ρ in relation to the maximum intensity.

Several factors contribute to the spread in the image of a point source, but the major one is diffraction of light waves (CRef. 1.213). When the **entrance pupil** of the eye is smaller than ~ 2 - 2.5 mm in diameter, the eye acts as a diffraction-limited device, and the point-spread function of the eye is roughly identical to the function derived from diffraction theory (CRef. 1.213). At these small pupil sizes, the width of the point-spread function decreases as pupil size increases. As the entrance pupil enlarges beyond ~ 2.5 mm, however, the point-spread function does not become proportionally narrower as it would if the eye were diffraction limited. When the entrance pupil is larger than ~ 5 mm, the point-spread function widens due to aberrations of the eye.

A line may be considered to be comprised of a string of finely spaced points. The retinal distribution of light in the image of the line can then be determined by convoluting the line pattern with the point-spread function of the eye given in Fig. 1. The light distribution resulting from such a convolution is illustrated in Fig. 2.

Applications

In theory, the retinal distribution of light produced by any target pattern can be determined from the point-spread function of the eye by decomposing the pattern into a series of points which are then convoluted with the point-spread function.

Constraints

- The degree of spread of the optical image is influenced by pupil size, the wavelength of the light, chromatic aberration of the eye, and the angle of light entry into the pupil.

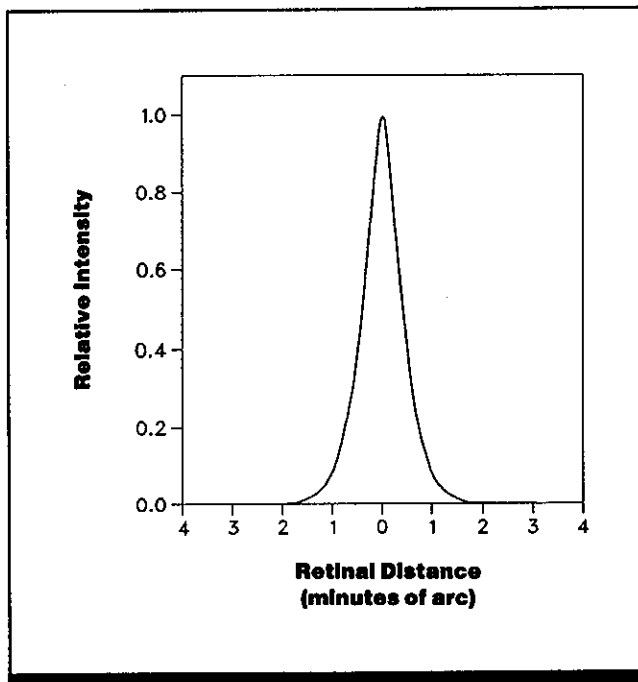

Figure 1. Point-spread function of the human eye with good focus, medium pupil diameter (~ 3 mm), and white light. (From Ref. 6)

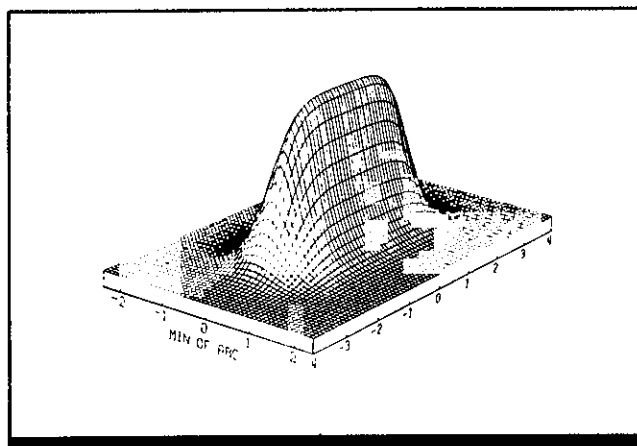

Figure 2. Retinal light distribution of line segment 4 min long created by a row of 25 points 10 sec arc apart. The image light distribution was calculated by convoluting the object pattern with the point-spread function of the eye shown in Fig. 1. (From Ref. 5)

- While the width of the point-spread function increases somewhat in the peripheral visual field, the degradation of the optical image is not sufficient to account for the observed deterioration of acuity in this portion of the visual field.

Table 1. Retinal light distribution for a point source of light. (Adapted from Ref. 6)

Distance from Center of Image (min arc)	Relative Height of Point-spread Function	Color
0.0	1.000	yellow
0.2	0.754	yellow
0.4	0.481	yellow
0.6	0.279	yellow
0.8	0.150	yellow
1.0	0.076	yellow
1.2	0.036	yellow
1.4	0.017	yellow
1.6	0.007	yellow
1.8	0.003	yellowish-white
2.0	0.001	yellowish-white
2.2	0.000	greenish-white

Note: Table gives the intensity (relative to the maximum) and color of the retinal image as a function of distance from the center of the image. Image intensity corresponds to the values of Fig. 1 and Eq. 1 for a pupil diameter of ~3 mm. Image color is for a white source and 4 mm pupil as calculated in Ref. 2 from the diameters and luminosities of the aberration disks for different wavelengths (spread in the image of a point source on the retina due to differences in the focal length of the eye for light of different wavelengths) and verified by direct observation using imagery formed by telescope and microscope.

Key References

1. Born, M., & Wolf, E. (1965). *Principles of optics* (Rev. 3rd ed.). New York: Pergamon.

*2. Hartridge, H. (1947). The visual perception of fine detail. *Philosophical Transactions*, B232, 519-668.

3. Jennings, J. A. M., & Charman, W. N. (1981). Off-axis image quality in the human eye. *Vision Research*, 21, 445-455.

4. Leibowitz, H. (1952). The effect of pupil size on visual acuity for photometrically equated test fields at various levels of luminance.

Journal of the Optical Society of America, 42, 416-422.

*5. Westheimer, G. (1979). The spatial sense of the eye. Proctor Lecture. *Investigative Ophthalmology and Visual Science*, 18, 893-912.

*6. Westheimer, G. (1986). The eye as an optical instrument. In K. R. Boff, L. Kaufman, & J. P. Thomas (Eds.), *Handbook of perception and human performance: Vol. 1. Sensory processes and perception*. New York: Wiley.

Cross References

1.203 The eye as an optical instrument;

1.211 Spherical aberration;

1.213 Diffraction of light in optical systems;

1.215 The line-spread function of the eye;

1.217 Retinal light distribution for an extended source

1.215 The Line-Spread Function of the Eye

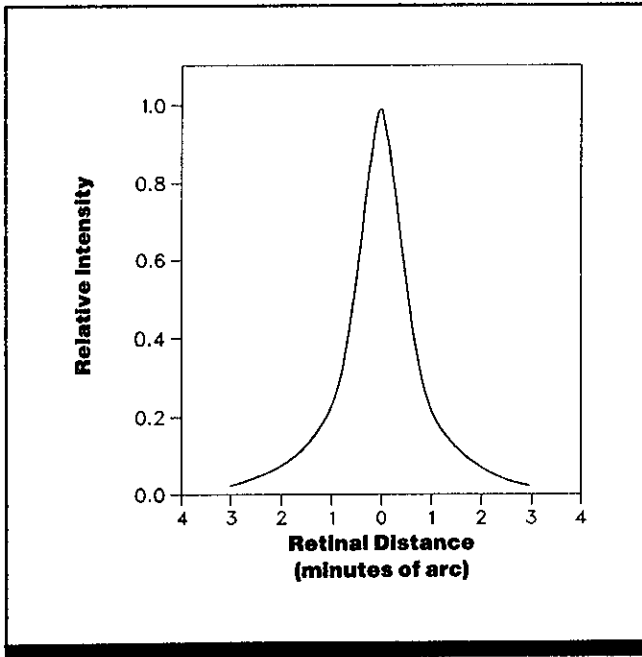

Figure 1. Line-spread function of the human eye in good focus. An empirical expression for this light distribution is given in Eq. 1. (From Ref. 5)

Key Terms

Diffraction; eye focus; image intensity distribution; light scatter; line-spread function; point-spread function; retinal image; visual acuity; visual image

General Description

Because of physical and geometric optical factors, a sharp, narrow line is not imaged as a sharp line on the retina of the eye; rather, the image is blurred somewhat. The resulting distribution of light in the retinal image of the line is bell-shaped in cross section with a series of color fringes. This light distribution is described by the *line-spread function* of the eye. Many factors contribute to the spread of light in the image of a line, but one of the most important is the diffraction of light waves (CRef. 1.213).

The line-spread function of the eye can be derived by relatively simple calculation from the *point-spread function*, i.e., the distribution of light in the retinal image of a point source of light (CRefs. 1.213, 1.214), in the following way. A line can be considered as comprised of a string of points spaced very closely together. Then the image of the line is simply the superimposed images of the points that comprise it, and the distribution of light in the image of the line can be determined by convolution of the point-spread function with the line pattern. For a radially symmetrical point-spread function $s(\rho)$, the corresponding line-spread function $A(\alpha)$ is given by

$$A(\alpha) = 2 \int_{\alpha}^{\infty} s(\rho) (\rho^2 - \alpha^2)^{-1/2} \rho d\rho \quad (1)$$

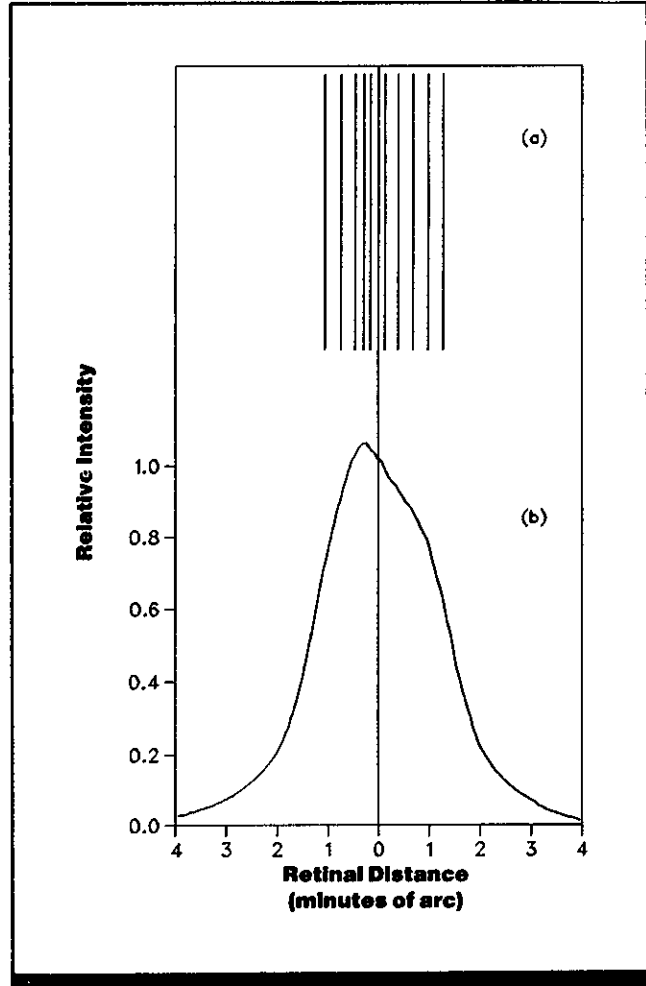

Figure 2. The retinal light distribution for a complex object pattern obtained by convolution. (a) Object pattern of ten lines. (b) Retinal light distribution in a slice through the middle of the image, calculated by convoluting the object pattern with the line-spread function of the eye shown in Fig. 1. (From Ref. 5)

where α is the distance from the geometrical image of the line in a direction normal to the line, and ρ is the radial distance from the center of the geometrical point image, both in minutes of arc of visual angle.

The line-spread function of the eye has been determined empirically by forming the image of a narrow, luminous line on the retina, measuring the distribution of light when the retinal image is reflected back through an ophthalmoscope, and then correcting the data for the fact that the light passes twice through the media of the eye (Refs. 4, 6).

Figure 1 shows the line-spread function for the eye, and Table 1 provides a tabulation of the function for different distances along the image. The intensity of light, $A(\alpha)$, at a

given point in the image of a line can be calculated using Eq. 2, which is an empirical expression of the function in Fig. 1:

$$A(\alpha) = 0.47 \exp(-3.3\alpha^2) + 0.53 \exp(-0.93|\alpha|) \quad (2)$$

where α is the distance from the geometrical image of the

line in a direction normal to the line in minutes of arc of visual angle.

Complex objects can be convoluted with the eye's line-spread function to yield the light distribution on the retina. Figure 2 shows a cross section of the light distribution of a set of lines.

Applications

Complex targets can be convoluted with the line-spread function of the eye to determine the light distribution of the target image on the retina.

Constraints

• The degree of spread of the optical image is influenced by pupil size, the wavelength of the light, chromatic aberration of the eye, and the direction of light entry into the pupil.

- The width of the line-spread function increases as focus is degraded (CRef. 1.216).
- The width of the line-spread function increases as distance from the fovea increases (i.e., in peripheral vision).

Key References

1. Gubisch, R. W. (1967). Optical performance of the human eye. *Journal of the Optical Society of America*, 57, 407-415.
 *2. Hartridge, H. (1947). The visual perception of fine detail. *Philosophical Transactions, B232*, 519-668.

3. Jennings, J. A. M., & Charman, W. N. (1981). Off-axis image quality in the human eye. *Vision Research*, 21, 445-455.
 4. Krauskopf, J. (1962). Light distribution in human retinal images. *Journal of the Optical Society of America*, 52, 1046-1050.

*5. Westheimer, G. (1986). The eye as an optical instrument. In K. R. Boff, L. Kaufman, & J. P. Thomas (Eds.), *Handbook of perception and human performance*.

Vol. 1. Sensory processes and perception. New York: Wiley.
 6. Westheimer, G., & Campbell, F. W. (1962). Light distribution in the image formed by the living human eye. *Journal of the Optical Society of America*, 52, 1040-1045.

Cross References

1.203 The eye as an optical instrument;
 1.211 Spherical aberration;

1.213 Diffraction of light in optical systems;
 1.214 The point-spread function of the eye;

1.216 Width of the line-spread function: effect of visual field location and eye focus;
 1.217 Retinal light distribution for an extended source

Table 1. Retinal light distribution for a line target. (Adapted from Ref. 5)

Distance from Center of Image (min arc)	Relative Height of Line-Spread Function	Color
0.0	1.000	yellow
0.2	0.852	yellowish-white
0.4	0.643	yellowish-white
0.6	0.447	yellowish-white
0.8	0.309	cream
1.0	0.226	cream
1.2	0.178	cream
1.4	0.145	cream
1.6	0.120	cream
1.8	0.099	white
2.0	0.083	white
2.2	0.069	white
2.4	0.570	white
2.6	0.047	white
2.8	0.039	white
3.0	0.033	greenish-white
3.2	0.027	bluish-white
3.4	0.022	bluish-white
3.6	0.019	bluish-white
3.8	0.015	purple
4.0	0.013	purple
4.2	0.011	purple
4.4	0.009	blue
4.6	0.007	blue
4.8	0.006	blue
5.0	0.005	blue

Note: Table gives the intensity (relative to the maximum) and color of the retinal image as a function of distance from the center of the image in a direction normal to the line. Image intensity corresponds to the values of Fig. 1 and Eq. 2. Image color is for a white line and 4 mm pupil as calculated in Ref. 2 from the diameters and luminosities of the aberration disks for different wavelengths (spread in the image of a point source on the retina due to differences in the focal length of the eye for light of different wavelengths).

1.216 Width of the Line-Spread Function: Effect of Visual Field Location and Eye Focus

Key Terms

Diffraction; eye focus; line-spread function; retinal image; retinal location; visual field location; visual image

General Description

The quality of the retinal image of a small, narrow target line decreases moderately with an increase in peripheral angle, (i.e., the distance of the image from the optical axis of the eye ~ 5 deg nasal to the **primary line of sight**). Figure 1 shows that the line-spread function (intensity distribution of the retinal image of the target line; CRef. 1.215) remains constant throughout a central region of ~ 25 deg, then gradually becomes wider as peripheral angle increases. The line-spread function becomes narrower with better focus at a given peripheral angle.

Methods

Test Conditions

- Viewing slit 100 μm wide, vertical or horizontal presentation; viewing distance 34.5 cm (2.9 diopters); fixation on dimly illuminated flashlight bulb seen through mirror; accommodation (eye focus) prevented by drugs; focus of retinal image varied by use of ophthalmic trial lenses near eye, 3.0-diopter range
- Reflected retinal image scanned by double-pass photoelectric instrument across fixed slit in front of photomultiplier; spectral sensitivity of apparatus similar to that of standard color-vision observer
- Measurements taken in white light, at 5-deg intervals across central 80 deg of horizontal retinal meridian in both eyes; head position

maintained by biteplate and head-rest; 7.5-mm pupil dilation maintained chemically

Experimental Procedure

- Computer-averaged external line-spread functions measured by photoelectric instrument from reflected retinal image
- Independent variables: orientation of target slit, angular displacement of target slit image on retina, focus of target slit image
- Dependent variable: external line-spread function halfwidth (full width at half-height of line-spread reflected from retina)
- Observer's task: maintain fixation and stationary eye position
- 1 subject

Experimental Results

- The quality of the retinal image (as measured by the width of the line-spread function) is relatively constant over a central region of ~ 25 deg (measured from the optical axis of the eye) and then deteriorates mildly toward the periphery across the central 80 deg of the eye's horizontal meridian. As the peripheral angle increases, line-spread function halfwidths gradually widen from ~ 11.5 to ~ 30 min arc of visual angle.
- Line-spread functions become narrower with better spectacle lens focus at a given peripheral angle; the narrowest line-spread halfwidth indicates optimal focus.

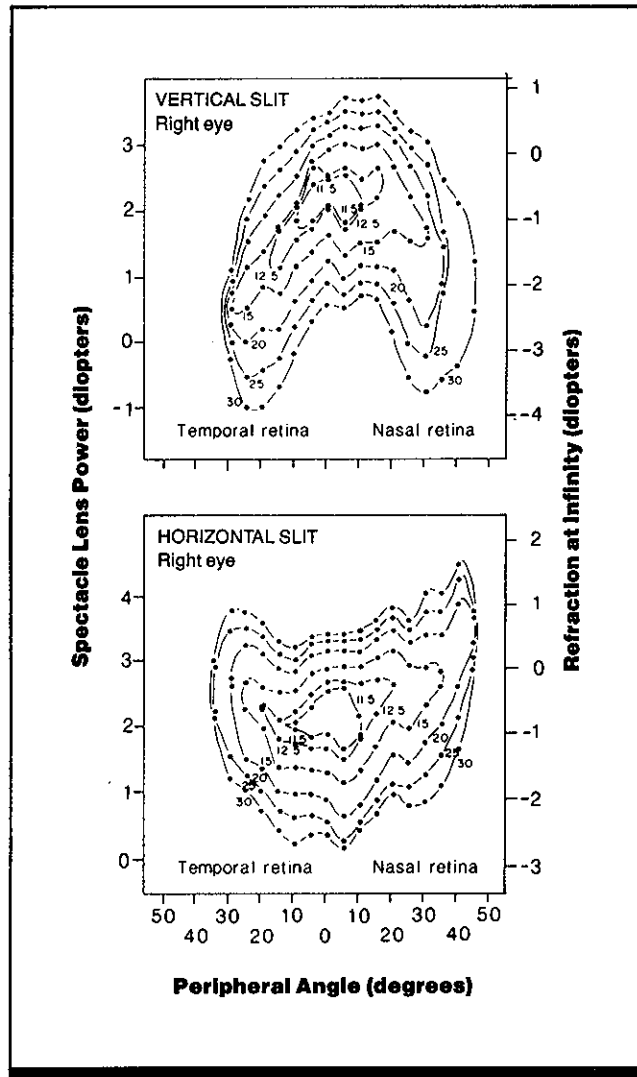

Figure 1. Image quality (external line-spread function halfwidth) as a function of peripheral angle (distance from optical axis) and focus setting. Contours join points of equal external line-spread function halfwidth for targets presented along the horizontal meridian of the retina; numbers on the contours refer to halfwidth in min arc of visual angle. Left ordinate indicates focus setting of lens placed over eye. Right ordinate indicates refraction at infinity after correction at lens power for target distance. Best state of focus for each peripheral angle is shown by the lens ordinate point on the contour with the narrowest line spread. Data are for the observer's right eye, measured with vertical and horizontal slits. (From Ref. 1)

- Refraction at infinity (right ordinate of Fig. 1) is determined by correcting for the fixation distance of the target slit.
- Mathematical analysis of external (reflected) line-spread data indicates that they realistically represent relative line spreads at the retina (unreflected) under normal conditions (i.e., focus by accommodation and peripheral refraction determined by the pattern of oblique astigmatism). This is

shown by a constant ratio (mean = 2.8 min arc, standard deviation = 0.7) between external line-spread halfwidths and computed halfwidths for the retina.

Variability

Variability is not reported, but Ref. 3 notes that considerable inter-observer variability can be expected.

Constraints

- Data were obtained from the dilated pupil. With normal accommodation, smaller pupils may prevent optimal focus and quality of the peripheral retinal image, due to diffraction and peripheral refraction of the eye (CRefs. 1.111, 1.204).

Key References

<p>*1. Jennings, J. A. M., & Charman, W. N. (1981). Off-axis image quality in the human eye. <i>Vision Research</i>, 21, 445-455.</p>	<p>2. Leibowitz, H. (1952). The effect of pupil size on visual acuity for photometrically equated test fields at various levels of luminance. <i>Journal of the Optical Society of America</i>, 42, 416-422.</p>	<p>3. Westheimer, G. (1986). The eye as an optical instrument. In K. R. Boff, L. Kaufman, & J. P. Thomas (Eds.), <i>Handbook of perception and human performance: Vol. 1. Sensory processes and perception</i>. New York: Wiley.</p>
---	--	--

Cross References

<p>1.111 Luminous efficiency: effect of pupil entry angle;</p> <p>1.201 Anatomy of the human eye;</p>	<p>1.204 Spherical refractive errors;</p> <p>1.213 Diffraction of light in optical systems;</p> <p>1.214 The point-spread function of the eye;</p>	<p>1.215 The line-spread function of the eye;</p> <p>1.221 Image quality and depth of focus</p>
---	--	---

1.217 Retinal Light Distribution for an Extended Source

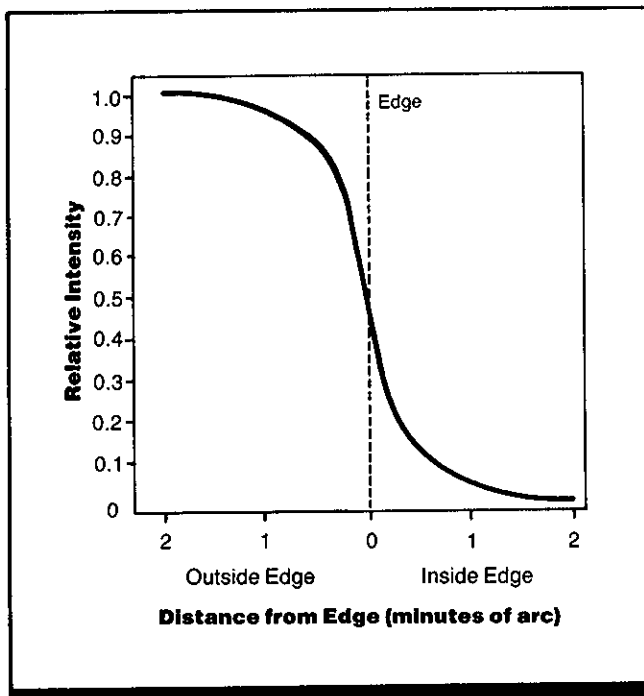

Figure 1. Relative light distribution on the retina of a bright (white) area (extended source) against a dark background for the human eye in good focus with a 4-mm pupil. Curve is derived from the values in Table 1.

Key Terms

Diffraction; eye focus; image intensity distribution; light scatter; retinal image; visual image

General Description

A sharp edge is not imaged by the eye as a sharp change in the distribution of light. There is, rather, a gradual change in the light distribution, and the retinal image of the edge is somewhat dispersed and fuzzy, with a series of colored fringes. The major cause of this dispersion is the diffraction

of light waves (CRef. 1.213). Figure 1 and Table 1 show the relative intensity of light in the retinal image of a white area viewed against a dark background as a function of distance from the edge separating the bright and dark areas.

Constraints

- These values are the result of calculations based on assumed dimensions of the observer's eye.
- The degree of spread of the optical image is also influenced by the size of the pupil, the wavelength of the light, location in the field of view, and the angle of light entry into the pupil.

Table 1. Light distribution in the retinal image of a bright (white) area (extended source) against a dark background. (Adapted from Ref. 2)

Distance from Edge (min arc)	Relative intensity	Color
2.0	1.000	white
1.8	0.998	cream
1.6	0.996	cream
1.4	0.989	cream
1.2	0.977	pale yellow
1.0	0.961	pale yellow
0.8	0.938	pale yellow
0.6	0.904	yellow
0.4	0.861	yellow
0.2 Inside Edge	0.720	yellow
0.0 Edge	0.500	yellow
0.2 Outside Edge	0.280	white
0.4	0.139	blue
0.6	0.096	blue
0.8	0.062	blue
1.0	0.039	dark blue
1.2	0.023	dark blue
1.4	0.011	dark blue
1.6	0.004	deep violet
1.8	0.002	deep violet
2.0	0.000	black

Note: Table gives the intensity (relative to the maximum) and color of the retinal image as a function of distance from the edge separating the white area from the dark background. Values represent calculations for a 4-mm pupil derived from the diameters and luminosities of the aberration disks for different wavelengths (i.e., spread in the image of a point source on the retina due to differences in the focal length of the eye for light of different wavelengths).

Key References

1. Bartley, S. H. (1951). The psychophysiology of vision. In S. S. Stevens (Ed.), *Handbook of experimental psychology* (pp. 921-984). New York: Wiley.

*2. Hartridge, H. (1947). The visual perception of fine detail. *Philosophical Transactions*, B232, 519-668.

Cross References

1.203 The eye as an optical instrument;

1.211 Spherical aberration;

1.213 Diffraction of light in optical systems;

1.214 The point-spread function of the eye;

1.215 The line-spread function of the eye

1.218 Fourier Description of the Eye's Imaging Property

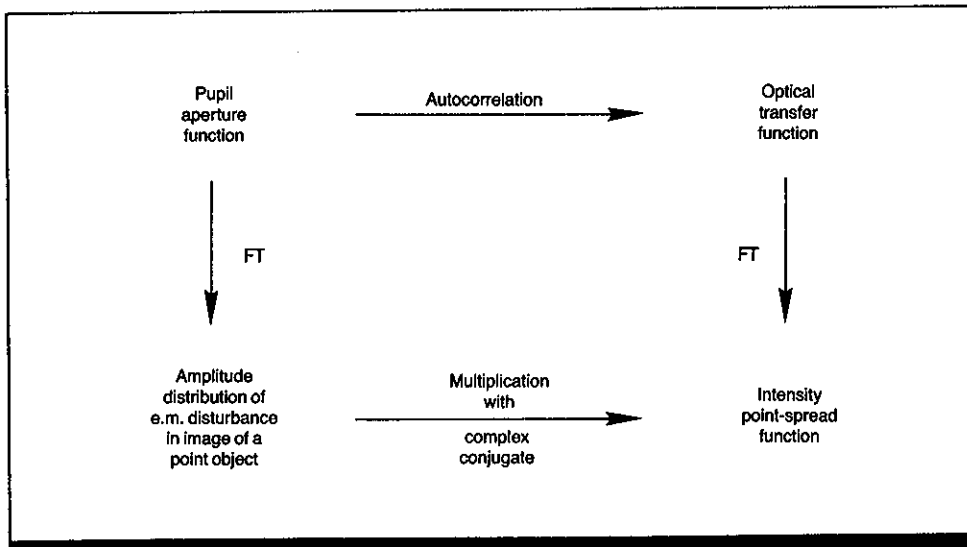

Figure 1. The relationship between the pupil aperture function of an optical system, the optical transfer function, the amplitude distribution of electromagnetic disturbance in the image of a point object, and the intensity point-spread function. FT = Fourier transformation; e.m. = electro-magnetic. (Adapted from Ref. 2)

Key Terms

Eye focus; image intensity distribution; modulation transfer function; optical transfer function; point-spread function; pupil-aperture function; retinal image; visual image

General Description

The image of an object produced by any optical imaging device, including the eye, exhibits a certain amount of fuzziness or spread; the amount of spread depends on the quality of the device. The limiting factor on the sharpness of the image is the diffraction of the light waves. The amount of image spread due to diffraction can be calculated with diffraction equations, but a simpler and equivalent way of examining the properties of imaging systems is to use Fourier transforms.

Figure 1 schematizes the relationships between four descriptors of the image-forming properties of an optical device. The light distribution of an object is invariably degraded by the optical system, and the image will not be a perfect reproduction of the object's light distribution. The human eye, like any optical imaging device, has a set of properties that determines how good an image it can produce. The most basic property is the size of the aperture through which the light must pass. Every visible object produces a certain spatial distribution of light intensities that is a collection of **spatial frequencies**. The size of the aperture determines the range of frequencies transmitted and thus sets the limits of resolution; this is called the pupil aperture function.

Any distribution of light intensities, no matter how complex, can be regarded as composed of **sinewaves** of various frequencies, amplitudes, and phases. Fourier analysis is a method of breaking down a complex intensity distribution into its constituent sinewaves. In doing so, spatial information is transformed into frequency information, or vice versa. The Fourier transformation of the aperture function takes the spatial frequencies transmitted by the aperture and yields the spatial image of the object with its amplitude distortions. This result, when multiplied with the complex conjugate (which represents "fuzziness" of an image), yields the intensity point-spread function—the amount of spread of the image. If the original object was a point of light, the result is a description of how the image of that point is spread out on the retina.

The point-spread function can also be obtained another way. Performing an autocorrelation on the pupil aperture function yields the optical transfer function. This specifies the accuracy with which each spatial frequency transmitted through the aperture is imaged by the optical system—that is, the accuracy with which the various spatial frequencies are transferred to the image. For the eye, this is called the modulation transfer function. When this function is subjected to a Fourier transformation, the frequency information is transformed to spatial information, yielding the intensity point-spread function.

Applications

Fourier analysis is a powerful and widely used method of analyzing the response of optical systems to stimuli.

Constraints

- The method is restricted to the relationship between the light distribution of the object and its coordinated retinal image.
- The method assumes that the system is linear, homogeneous, and isotropic.

Key References

1. Cornsweet, T. N. (1970). *Visual perception*. New York: Academic Press.

*2. Westheimer, G. (1986). The eye as an optical instrument. In

K. R. Boff, L. Kaufman, & J. P. Thomas (Eds.), *Handbook of perception and human performance: Vol. 1. Sensory processes and perception*. New York: Wiley.

Cross References

1.203 The eye as an optical instrument;

1.213 Diffraction of light in optical systems;

1.214 The point-spread function of the eye;

1.215 The line-spread function of the eye;

1.219 Modulation transfer function of optical systems

1.219 Modulation Transfer Function of Optical Systems

Key Terms

Contrast modulation; diffraction; eye focus; image intensity distribution; modulation transfer function; optical transfer function; retinal image; visual image

General Description

The image of an object produced by any optical imaging device is always degraded to some extent; the amount of degradation depends on the quality of the device and can be calculated by convolution. In the convolution calculations, the light distribution of an object is dissected into its individual points of light; the contributions from all these points are weighted for distance and then summed using Eq. 1 (Table 2) to give the spatial intensity distribution of the image (expressed in rectangular coordinates). Without a computer, this is a very time-consuming calculation. Another method is to measure the fidelity with which the device produces images of various **sine waves** that have the same amplitude but different **spatial frequencies**. Typically, low spatial frequencies (sine-wave patterns with wide bars) are imaged with good fidelity, but the image begins to deteriorate as the frequency increases (i.e., as the size of the bars of the sine-wave pattern decreases). When the sine waves become small enough, the device cannot resolve them and blurs the bars of the pattern together; this is the (upper) spatial frequency cut-off.

A basic property of an optical device that determines the upper frequency cut-off (and thus the quality of the image) is the size of the aperture through which the light must pass. Table 1 gives the relationship between the pupil diameter of the eye and the spatial frequency cut-off. The size of sine waves that *cannot* be imaged by the eye increases as the pupil size decreases (i.e., larger and larger sine waves cannot be resolved).

Contrast modulation (or modulation) is $(I_{max} - I_{min}) / (I_{max} + I_{min})$, where I is intensity. A graph of how well the optical device reproduces or "transfers" the spatial intensity modulations of each of the various sine waves to the image is called a *modulation transfer function (MTF)*. An MTF graph plots the ratio of image contrast to object contrast against spatial intensity. Figure 1 shows such a curve for an optical system such as the eye for a given aperture size and wavelength of light. This optical device cannot image spatial frequencies >1 cycle/deg.

The modulation transfer function is extremely useful because it is mathematically equivalent to the much less convenient convolution process. The degradation in the image can be calculated by multiplying the MTF by the Fourier transform of the light distribution of the object. These calculations, which use Eq. 2, involve spatial frequencies in cycles/degree of visual angle rather than the actual spatial distribution of the image; they yield the Fourier transform of the light distribution of the image. It is then necessary to convert these results into the light distribution of the image. When the light distribution is circular and symmetrical, like a disk or an annulus, a special form of the equation, Eq. 3, is used.

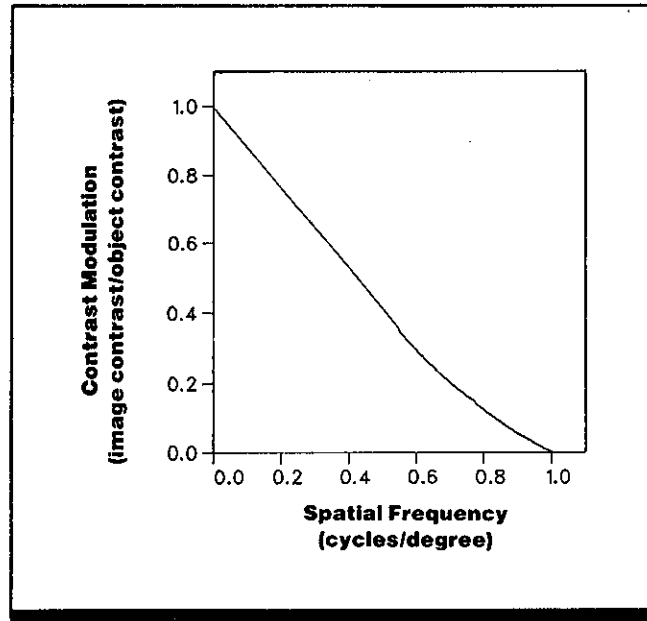

Figure 1. Modulation transfer function of an optical system such as the eye without aberrations, for monochromatic light and a round pupil. Abscissa is scaled in spatial frequency referred to cutoff spatial frequency (spatial frequency at and beyond which no components are represented in the image). (From Ref. 2)

Table 1. Relationship between (upper) spatial frequency cut-off of the eye's optical transfer function and pupil diameter for light of wavelength 555 nm. (From Ref. 2)

Pupil Diameter (mm)	Cutoff Spatial Frequency (cycles/degree)
0.5	15.6
1	31.3
1.5	48.0
2	62.6*
3	**
4	**
5	**
6	**

Note: The cutoff spatial frequencies shown are calculated from the diffraction limit of an optical system of the given pupil diameter. For pupil diameter larger than 2-2.5 mm, the theoretical cutoff spatial frequency increases in direct proportion to the pupil diameter, but actually the eye cannot perform at the theoretical limit due to aberrations.

*0.96 min arc/cycle

**No longer diffraction-limited.

Constraints

- The selection of one procedure (convolution or Fourier technique) over the other is a matter of convenience.
- These methods assume that the optical system under consideration is linear, homogeneous, and isotropic.

Key References

1. Cornsweet, T. N. (1970). *Visual perception*. New York: Academic Press.
- *2. Westheimer, G. (1986). The eye as an optical instrument. In K. R. Boff, L. Kaufman, & J. P. Thomas (Eds.), *Handbook of perception and human performance: Vol. 1. Sensory processes and perception* New York: Wiley.

Cross References

- 1.214 The point-spread function of the eye;
- 1.215 The line-spread function of the eye;
- 1.218 Fourier description of the eye's imaging property;
- 1.220 Modulation transfer function of the eye for defocused imagery

Table 2. Equations for determining the light distribution in the optical image of an object.

Equation 1. Convolution equation in rectangular image coordinates, α, β . $I(\alpha, \beta)$ is the total image spread; $S(\alpha_0, \beta_0)$ is the spread function in rectangular coordinates; and $O(\alpha_0, \beta_0)$ is the image without any spreading. The total image spread is obtained by calculating the point-spread function (CRef. 1.214) of each object point α_0, β_0 and summing all points.

$$I(\alpha, \beta) = \int \int_{\text{object}} O(\alpha - \alpha_0, \beta - \beta_0) S(\alpha_0, \beta_0) d\alpha_0 d\beta_0 \quad (1)$$

Equation 2. Equation for the Fourier transform of the light distribution of an image. $I(\alpha, \beta)$ is light distribution in the image plane; $O(\omega_\alpha, \omega_\beta)$ is the Fourier transform of the object; $t(\omega_\alpha, \omega_\beta)$ is the modulation transfer function; α and β are rectangular coordinates in the image plane expressed in visual angle; and ω_α and ω_β are spatial frequency coordinates in the same two directions.

$$I(\alpha, \beta) = \int \int_{-\infty}^{\infty} O(\omega_\alpha, \omega_\beta) e^{-2\pi i(\alpha\omega_\alpha + \beta\omega_\beta)} t(\omega_\alpha, \omega_\beta) d\omega_\alpha d\omega_\beta \quad (2)$$

Equation 3. Special form of Eq. 2 used when the object is circular and symmetrical. $I(\rho)$ is the light distribution of the image; ρ is the radial distance from the center of the geometrical image; $O(\omega)$ is the Fourier transform of the object pattern; $t(\omega)$ is the optical transform function; and J_0 is zero-order Bessel function.

$$I(\rho) = 2\pi \int_0^{\infty} O(\omega) \cdot J_0(2\pi\rho\omega) t(\omega) \rho d\omega \quad (3)$$

1.220 Modulation Transfer Function of the Eye for Defocused Imagery

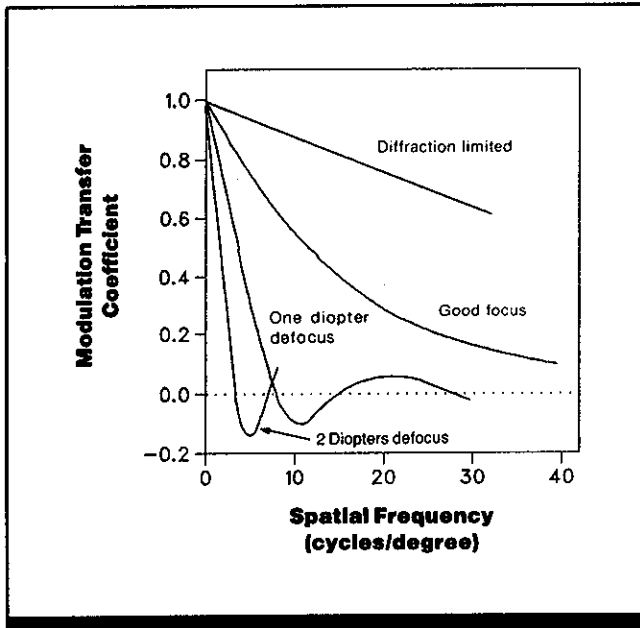

Figure 1. Modulation transfer function for defocused imagery. **Diffraction limited:** theoretical modulation transfer function of an eye in perfect focus without aberrations for a pupil diameter of 3 mm and monochromatic light of a median photopic wavelength. **Good focus:** best current estimate of the actual modulation transfer function of a good normal eye under similar conditions. **1 and 2 diopter defocus:** theoretical transfer functions of a normal eye with a 3-mm pupil defocused, respectively, by 1 and 2 diopters. A negative transfer coefficient means that a sinusoidal target is imaged with reversed contrast. (From Ref. 1)

Key Terms

Contrast modulation; diffraction; eye focus; image intensity distribution; modulation transfer function; optical transfer function; retinal image; visual image

General Description

The ability of an optical imaging device to transfer to an image the various **spatial frequencies** that make up the light distribution of an object is specified by the modulation transfer function (MTF). The MTF shows how well the image modulation reproduces the object modulation at each spatial frequency. This ability decreases as spatial frequency increases. When the object is not in perfect focus, the rate of deterioration with increasing spatial frequency is greater (Fig. 1). With defocusing, the modulation transfer

coefficients are negative in some frequency regions. These negative values mean that at these frequencies the object is imaged in reversed contrast (that is, the light distribution of the image is at a minimum when the light distribution of the object is at maximum). The MTFs for defocused imagery undergo oscillatory changes and may cross the zero point more than once before remaining strictly at zero beyond the cutoff spatial frequency (spatial frequency at and beyond which no components are represented in the image).

Constraints

- Curves are only approximate.
- The modulation transfer function depends critically on pupil diameter and wavelength of light.

Key References

*1. Westheimer, G., & McKee, S. P. (1980). Stereoscopic acuity with defocused and spatially filtered retinal images. *Journal of the Optical Society of America*, 70, 772-778.

Cross References

1.213 Diffraction of light in optical systems;

1.214 The point-spread function of the eye;

1.215 The line-spread function of the eye;

1.218 Fourier description of the eye's imaging property;

1.219 Modulation transfer function of optical systems

1.221 Image Quality and Depth of Focus

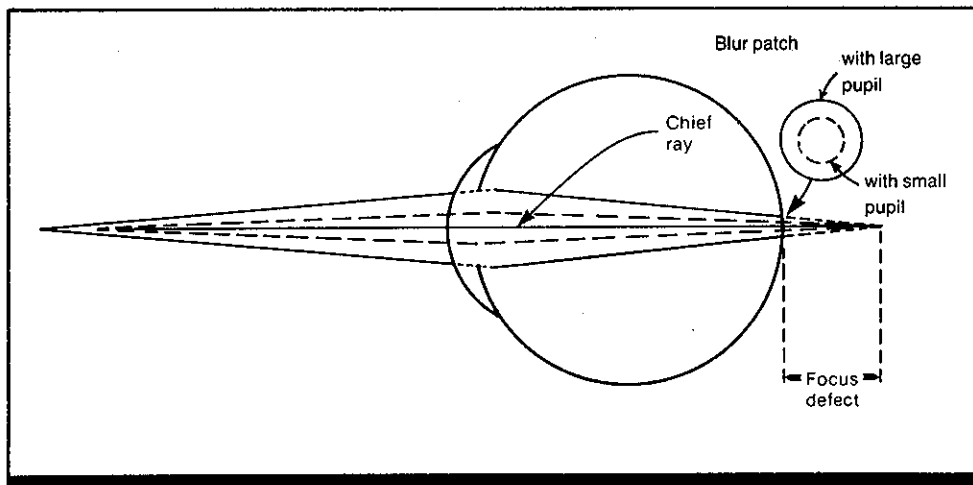

Figure 1. Passage of rays from a point object closer than infinity when the eye remains focused at infinity. Image-side bundle of rays intersects the retina in a blur patch (shown enlarged in the inset), which is centered on the chief ray and whose diameter is proportional to the pupil diameter and the focus defect. (Adapted from *Handbook of perception and human performance*)

Key Terms

Blur patch; depth of field; depth of focus; eye focus; focus defect; retinal image; visual image

General Description

When the eye is focused at infinity, light rays from an object not at infinity will converge in such a way that the point of focus would be behind the retina. Two sources at different distances from the eye will produce images that would be in focus at different distances behind the retina. When the point of focus of the image is behind the retina, the image formed on the retina itself is a blur patch (also called a blur disc or circle of confusion). The distance from the retina to the point of true focus for the object is called the focus defect. The size of the focus defect that can be tolerated without affecting performance is known as the depth of focus. The depth or range in object space corresponding to the depth of focus in image space (i.e., range for which objects will be sharply imaged on the retina) is called the depth of field.

For a given size of focus defect, the size of the blur patch is directly related to the size of the pupil. When the pupil contracts to half its diameter, the diameter of the blur patch is also reduced by half. The depth of focus increases as pupil size decreases; if the pupil contracts to half its diameter, the focus defect can be doubled and still yield the same size of blur patch.

Figure 1 illustrates the effect of pupil size on focus defect and the size of the blur patch. It can be seen how a smaller pupil would produce a sharper image (smaller blur patch) on the retina. The two photographs in Fig. 2 demonstrate the effect of aperture size on depth of field. Focus dis-

tance for both pictures is identical; however, the top photograph, taken through a larger iris opening, shows greater blurring of objects closer to and farther from the plane of best focus than the bottom photograph.

The depth of focus also depends on the distance to which the eye is fixated. If this distance is large (e.g., 100 m), an object may be moved several meters closer to the eye than the fixation point before the image becomes unacceptably blurred. If this distance is small (e.g., 25 cm), a displacement of 1 or 2 cm is enough to noticeably blur the image.

Reference 1 studied the depth of field of the human eye, using an apparatus with three transparent plates, each with a dot on it. The middle plate was fixed at a given distance, and subjects fixated on the dot on this plate, bringing it into sharp focus. The first and third plates, which were moveable, were initially placed in a position where they, also, were in sharp focus. To measure the depth of field, these plates were moved away from the middle plate until the subject could detect blur. A typical depth of focus for a 3-mm pupil is 0.25 diopters, so depth of focus for a 1.5-mm pupil would be expected to be 0.50 diopters and for a 6-mm pupil, 0.125 diopters. This result was obtained for a 1.5-mm pupil. Observed depth of focus deviated from the expectation for the larger pupil size; this deviation can be explained by the Stiles-Crawford effect (see Constraints).

Applications

Optical imaging devices (including the eye) can produce sharp images over a greater range of space by reducing the size of the aperture.

Constraints

- With a large pupil, the relation between pupil size and depth of focus is complicated by the Stiles-Crawford effect (a narrow beam of light entering the eye in isolation is less effective in eliciting a visual response if it enters at the edge of the pupil rather than at the center; CRef. 1.111).
- Values for depth of focus depend on the criterion of image sharpness used.
- Depending on the magnification of the optical device used, reducing aperture size to increase depth of focus may also produce dimmer images.
- For optical systems that are diffraction limited (i.e. nearly perfect), reducing aperture size reduces resolution in object space.

Key References

1. Campbell, F. W. (1957). The depth of field of the human eye. *Optica Acta*, 4, 157-164.
2. Cornsweet, T. N. (1970). *Visual perception*. New York: Academic Press.

Cross References

- 1.111 Luminous efficiency: effect of pupil entry angle;
- 1.203 The eye as an optical instrument;
- 1.214 The point-spread function of the eye;

- 1.215 The line-spread function of the eye;
- 1.222 Visual accommodation; *Handbook of perception and human performance*, Ch. 4, Sect. 1.5

...the subject's eye was 226 cm from the small end of the cone behind the background screen on the opposite compartment. The ring target was centered on this circular background and appeared as a uniform surround which extended from the center to beyond the subject's field of view. During the experiment, the background and surround lighting system were adjusted so that the inside cone surface and the background screen appeared as a homogeneous viewing field of approximated equal brightness.

The subject pushed one of eight pushbuttons to report the target gap orientation. To confirm his choice and permit correct feedback was provided to him by illuminating one of eight lamps behind the background screen in a 6-cm-diameter circle with the target. Activation of a switch, held in the subject's hand, automatically scored and recorded each response. The subject received audible right/wrong information by a buzzer for an incorrect response. This procedure has been found to yield a high performance (Blackwell, 1953).

The experimenter's console provided capability for adjusting target gap brightness levels, target gap orientation and independent control for initiating stimulus exposures. Meters and switches were used to individually monitor and regulate the intensity of the incandescent illuminators for the surround, background and target. Voltage transformers were used to supply the

illumination measurements were taken with a Spectra Spotmeter Model 1/2° and a Macbeth illuminometer. These meters were placed at the optical bench and filters. For surround and target brightness measurements were taken at several points along the lamp currents to achieve the desired brightness level while directing the brightness meter along an axis in the same position. All measurements were reported to the experimenter.

The subject was in this position with respect to the cone by a headrest behind the surround assembly. The subject's eye was 226 cm from the small end of the cone behind the background screen. Looking through the small end of the cone behind the background screen on the opposite compartment, the ring target was centered on this circular background and appeared as a uniform surround which extended from the center to beyond the subject's field of view. During the experiment, the background and surround lighting system were adjusted so that the inside cone surface and the background screen appeared as a homogeneous viewing field of approximated equal brightness.

The subject pushed one of eight pushbuttons to report the target gap orientation. To confirm his choice and permit correct feedback was provided to him by illuminating one of eight lamps behind the background screen in a 6-cm-diameter circle with the target. Activation of a switch, held in the subject's hand, automatically scored and recorded each response. The subject received audible right/wrong information by a buzzer for an incorrect response. This procedure has been found to yield a high performance (Blackwell, 1953).

The experimenter's console provided capability for adjusting target gap brightness levels, target gap orientation and independent control for initiating stimulus exposures. Meters and switches were used to individually monitor and regulate the intensity of the incandescent illuminators for the surround, background and target. Voltage transformers were used to supply the

illumination measurements were taken with a Spectra Spotmeter Model 1/2° and a Macbeth illuminometer. These meters were placed at the optical bench and filters. For surround and target brightness measurements were taken at several points along the lamp currents to achieve the desired brightness level while directing the brightness meter along an axis in the same position. All measurements were reported to the experimenter.

Figure 2. The effect of aperture size on depth of field. Focus distance is the same in both photographs, but the top photograph was taken through a larger iris opening. (Photo by H. Self)

1.222 Visual Accommodation

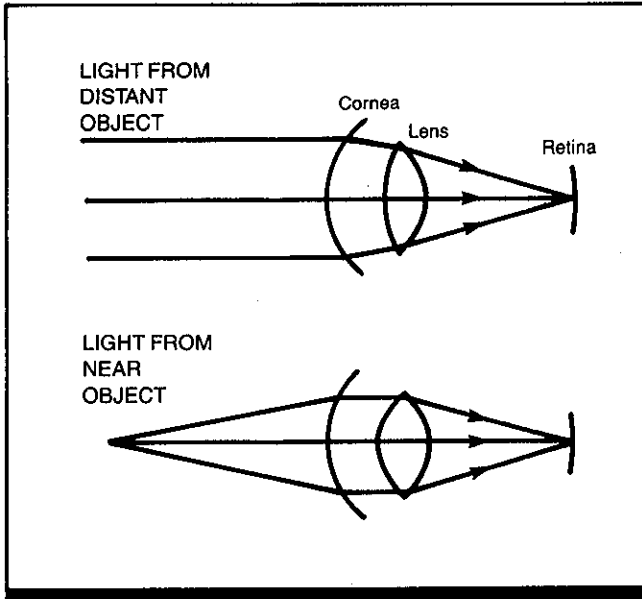

Figure 1. Accommodation. To bring objects at different distances into proper focus on the retina, the lens of the eye changes shape, altering the refractive power of the eye. (From Ref. 3)

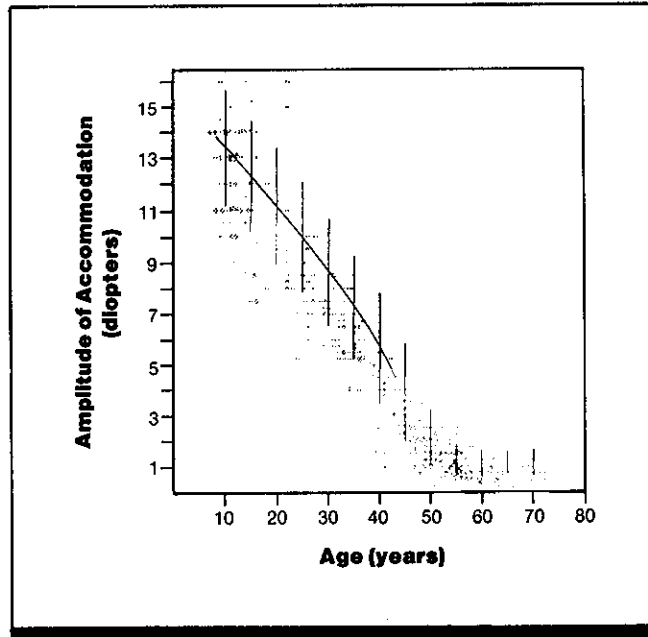

Figure 2. Amplitude of accommodation as a function of age, measured in 1000 eyes. Solid line and vertical brackets indicate accepted clinical norms. (From *Handbook of perception and human performance*, based on Ref. 4)

Key Terms

Accommodation; eye focus; lens; refraction

General Description

As with a camera, the eye can sharply focus at only one distance at any given moment; objects at other distances will be blurred, with the degree of blur increasing, the further objects are from the focused distance. The focus of a camera is changed by moving the lens so that images of objects at different distances will become sharp. In the eye, however, major optical structures are fixed in position with respect to the **retina**. Changes in focus are achieved by altering the total refractive power (or focal length) of the eye. This focusing is accomplished by changing the curvature and center thickness of the lens, particularly of its anterior surface—a process known as *accommodation*.

To focus on a distant object, the lens flattens, causing the refractive power of the eye to decrease. To focus on a nearby object, the curvature of the lens increases, raising total refractive power and maintaining image sharpness (Fig. 1). These changes are accomplished through the action of the ciliary muscle which surrounds the lens (CRef. 1.201). The lens is held in place by suspensory ligaments which exert a radial pull upon the lens, making it flatter. In a normal (**emmetropic**) eye, when no ciliary muscle effort opposes the tension exerted by the suspensory ligament, the lens is at its thinnest, its focal length is at a minimum, and

the eye is in focus for distant objects. When the ciliary muscle contracts, the tension of the ligaments is opposed, and the elasticity of the lens causes it to thicken or bulge, reducing its focal length and bringing near objects into focus. When the lens changes thickness to focus for a given object distance, the eye is said to accommodate. When the ciliary muscle is relaxed and the lens is at its flattest, i.e., focused for a very distant object (optical infinity), the eye is said to be unaccommodated.

The amount, or amplitude, of accommodation is generally expressed in diopters, which is the inverse of object distance from the eye in meters ($1/m$). For instance, an eye focused on an object at 0.25 m is accommodated 4 diopters ($1/0.25 = 4$). An eye focused on an object at infinity is said to be exerting zero accommodation. When the eye views a blank field, or in total darkness, the lens does not accommodate for infinite distance (0 diopters), but rather for a distance of ~ 59 cm (~ 1.7 diopters) (CRef. 1.223). This distance is the resting state of accommodation (Ref. 2).

The lens becomes harder and less elastic with age, so that the maximum amplitude of accommodation that can be exerted by the eye decreases; thus, close objects cannot be brought into sharp focus. Using a standard clinical proce-

ture which involves moving a card along a near-point rule toward the observer until the print becomes blurred and then moving it away until the print becomes clear again, Ref. 4 measured the amplitude of accommodation in both eyes of 500 people with normal acuity who ranged in age from under 13 to over 67. The recovery point was considered the maximum amplitude of accommodation. Maximum accommodation declines from a high of ~16 diopters (6 cm) in the young to <1 diopter (over 1 m) in the aged (Fig. 2).

The time course of the accommodative response was measured in Ref. 1 for six emmetropic adults (ages 20-40).

Measurements were made on the subjects' left eye with the pupil dilated; the right eye was covered. The stimulus for the accommodative response was a change in illumination from one neon lamp to another at a different distance. The lamps were 10 min arc in diameter and were adjusted to appear in alignment as viewed by the subjects. Under these conditions, the latency of response (the time from the onset of the stimulus until the beginning of the accommodative response) is ~0.3 sec and the response is essentially complete after ~0.8 sec (Fig. 3).

Constraints

- Most observers can comfortably maintain no more than about one-third the maximum amplitude of accommodation over any length of time.
- Accommodation is influenced by characteristics of the target stimulating accommodation, including luminance level, oscillatory and abrupt changes in target distance, and

the structure of the stimulus field (CRefs. 1.226, 1.228, 1.229, 1.230).

- Even when an observer is maintaining fixation on a target at a given distance, accommodation is not steady but fluctuates by as much as 0.5 diopters (CRef. 1.224).

Key References

<p>1. Campbell, F. W., & Westheimer, G. (1960). Dynamics of accommodative responses of the human eye. <i>Journal of Physiology</i>, 151, 285-295.</p>	<p>2. Emsley, H. H. (1939). <i>Visual optics</i> (2nd ed.). London: Hatton Press.</p> <p>3. Farrell, R.J., & Booth, J.M. (1984). <i>Design handbook for imagery interpretation equipment</i>. Seattle, WA: Boeing Aerospace Co.</p>	<p>4. Turner, M. J. (1958). Observations on the normal subjective amplitude of accommodation. <i>British Journal of Physiological Optics</i>, 15, 70-100.</p>
---	---	---

Cross References

<p>1.201 Anatomy of the human eye;</p> <p>1.223 Resting position of accommodation;</p> <p>1.224 Normal variation in accommodation;</p> <p>1.225 Normal variation in accommodation: similarity in the two eyes;</p>	<p>1.226 Visual accommodation: effect of luminance level and target structure;</p> <p>1.228 Accommodation: effect of dark focus, luminance level, and target distance;</p> <p>1.229 Accommodation: effect of oscillatory changes in target distance;</p>	<p>1.230 Accommodation: effect of abrupt changes in target distance;</p> <p>1.231 Relation between accommodation and convergence;</p> <p><i>Handbook of perception and human performance</i>, Ch. 4, Sect. 1.5</p>
--	--	--

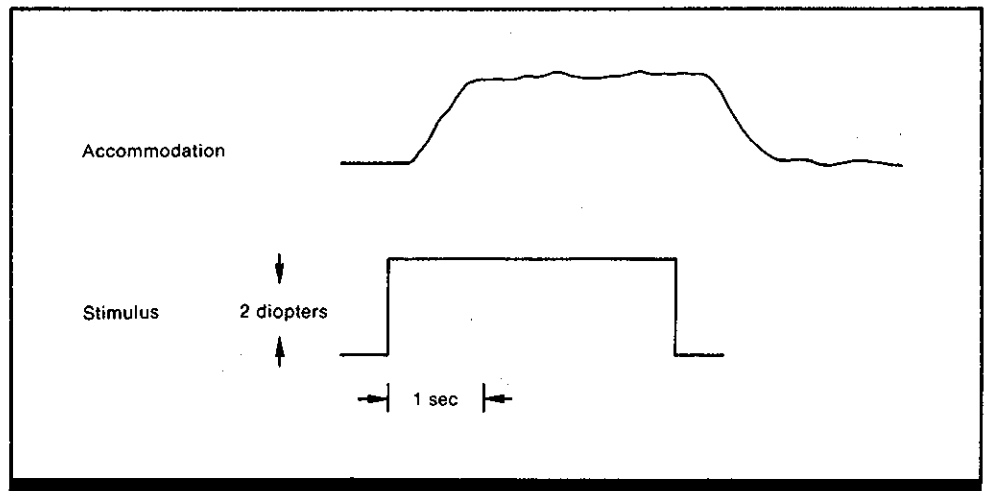

Figure 3. Time course of accommodation response to a 2-diopter step stimulus for one young subject. Latency is ~0.3 sec and total time elapsed between stimulus onset and final response level is nearly 1 sec. (From *Handbook of perception and human performance*, after Ref. 1)

1.223 Resting Position of Accommodation

Key Terms

Accommodation; dark focus; empty field myopia; eye focus; instrument myopia; lens; nearsightedness; night myopia; refraction; resting accommodation

General Description

When there is no visual stimulus to accommodation present in the visual field (e.g., in the dark), the eye is not focused to optical infinity, but rather adopts an intermediate, resting level of accommodation. On average, the resting position of accommodation in the dark is ~ 1.7 diopters (i.e., the eye is focused to a distance of ~ 59 cm), but varies from individual to individual (Fig. 1).

Under conditions where the visual target is degraded or the need for accommodation is absent, such as viewing in dim light, viewing a featureless scene, or viewing through optical instruments (especially microscopes), the eye becomes nearsighted; that is, the eye is accommodated for near distances, even though the objects of interest are located at far distances or at optical infinity. Nearsightedness under these conditions is known as night myopia, empty-field myopia, and instrument myopia, respectively. The accommodative state of the eye under these conditions correlates highly with the resting state of accommodation in the dark; this suggests that the nearsightedness commonly observed in such cases is due to a return of accommodation to the resting state (i.e., relatively near focus) because of the absence of an adequate stimulus to accommodation.

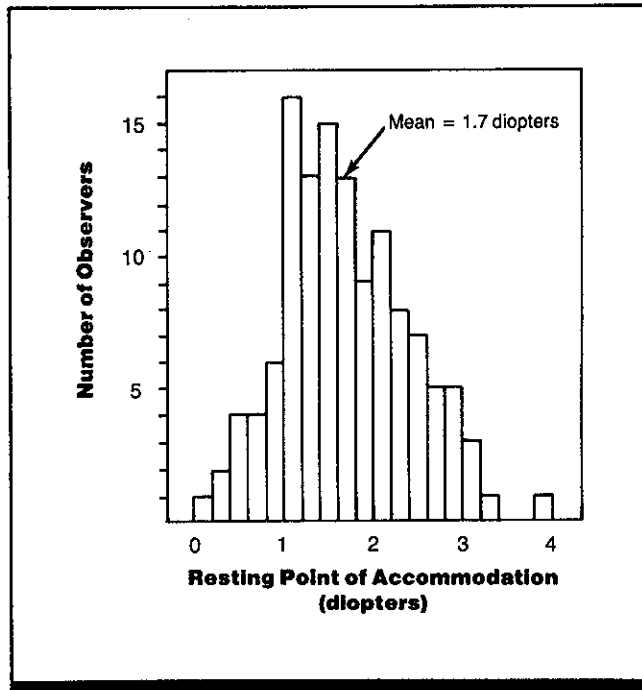

Figure 1. Frequency distribution of the amplitude of accommodation or eye focus in total darkness (resting accommodation), for 124 college-age observers. (After Ref. 1)

Applications

Viewing in darkness or dim light, in conditions approximating an empty field (e.g., high-altitude flight, heavy snow-storm, or fog), and through optical instruments, especially microscopes.

Methods

Test Conditions

- Accommodation measured using laser optometer; laser speckle pattern superimposed on field of view for 0.5 sec
- Total darkness condition; twilight condition; empty field condition produced by placing half a ping-pong ball against the eye; instrument condition produced by

viewing square-wave grating through a microscope with a 2-mm exit pupil

- Empty field illuminated to 153 cd/m²; microscope field illuminated to 11 cd/m²
- Monocular viewing

Experimental Procedure

- Method of limits
- Independent variables: luminance, type of visual field

- Dependent variable: amplitude of accommodation
- Observer's task: judge direction of motion of laser speckle pattern (as an indicator of accommodative distance)
- 124 observers, college students, for conditions of total darkness and twilight; 30 observers, college-age students, for empty field and instrument conditions

Experimental Results

- There are large individual differences in resting accommodation (i.e., focus distance in the dark) (Fig. 1).
- Mean resting accommodation is 1.7 diopters (59 cm) (Fig. 1); this represents nearsightedness (myopia), or focus to a relatively close distance.
- Correlations between resting accommodation and accom-

modation in very dim light, while viewing an empty field, and while viewing through a microscope are 0.84, 0.81, and 0.68, respectively.

Variability

The standard deviation of the mean resting accommodation was 0.72 diopter. Subsequent studies have found means of accommodation within 0.25 diopter of this value. Resting accommodation for an individual has been found to vary by ~0.25 diopter on retest.

Constraints

- Only college-age students were tested, and mean accommodation is affected by age.
 - Resting accommodation may be affected by fatigue, cognitive demands, and the color of the test laser.
-

Key References

*1. Leibowitz, H. W., & Owens, D. A. (1975). Anomalous myopias and the intermediate dark focus of accommodation. *Science*, 189, 646-648.

2. Leibowitz, H. W., & Owens, D. A. (1978). New evidence for the intermediate position of relaxed accommodation. *Documenta Ophthalmologica*, 46, 133-147.

Cross References

1.222 Visual accommodation;
1.224 Normal variation in accommodation;

1.227 Eye focus in dim illumination (night myopia);

1.228 Accommodation: effect of dark focus, luminance level, and target distance

1.224 Normal Variation in Accommodation

Key Terms

Accommodation; eye focus; lens; monocular viewing; pupil size; refraction; viewing distance

General Description

The focusing (**accommodation**) of the eye varies constantly when an observer maintains fixation on a target at a fixed distance, although the observer is unaware of this. The degree of fluctuation increases as target distance decreases, with **monocular** compared to **binocular** viewing, as pupil size increases, and when fixation is maintained at a given distance with no target present.

Methods (across studies)

Test Conditions

- Small, high-contrast targets
- Target distance from 0.2 m to optical infinity
- Pupils sometimes dilated with drugs; in most cases, artificial pupil used

- or absence of target, target distance, pupil size, monocular versus binocular viewing
- Dependent variable: accommodative state
- Observer's task: maintain target in focus or maintain steady focus in absence of target
- 5 trained observers in one study (ages 24-40 yrs); 8 young adults in another study; number of observers in other studies not specified

Experimental Procedure

- Accommodation measured with infrared optometer
- Independent variables: presence

Experimental Results

- Accommodation shows constant small fluctuations, even when the observer attempts to maintain steady fixation at a given target distance and the details of the target are in apparently good focus.
- Fluctuations in accommodation are greater for monocular than for binocular viewing.
- The amplitude of the fluctuations increases as target distance decreases and as pupil size increases.
- Fluctuations in accommodation are greater when no target is present (observer tries to maintain focus to a given distance) than when a target is viewed.

Figure 1. Fluctuations in accommodation over time while observer attempts to maintain steady focus. Scale on left indicates vertical distance corresponding to 1 diopter (D) for each set of measurements. Target distance and pupil diameter are indicated where known. Data are shown for: (a) empty visual field and near target (adapted from Ref. 2); (b) target at optical infinity and near target (adapted from Ref. 1); (c) target viewed through small and large artificial pupils (adapted from Ref. 1); (d) near target and far target (adapted from Ref. 5); and (e) binocular and monocular viewing of target (adapted from Ref. 4).

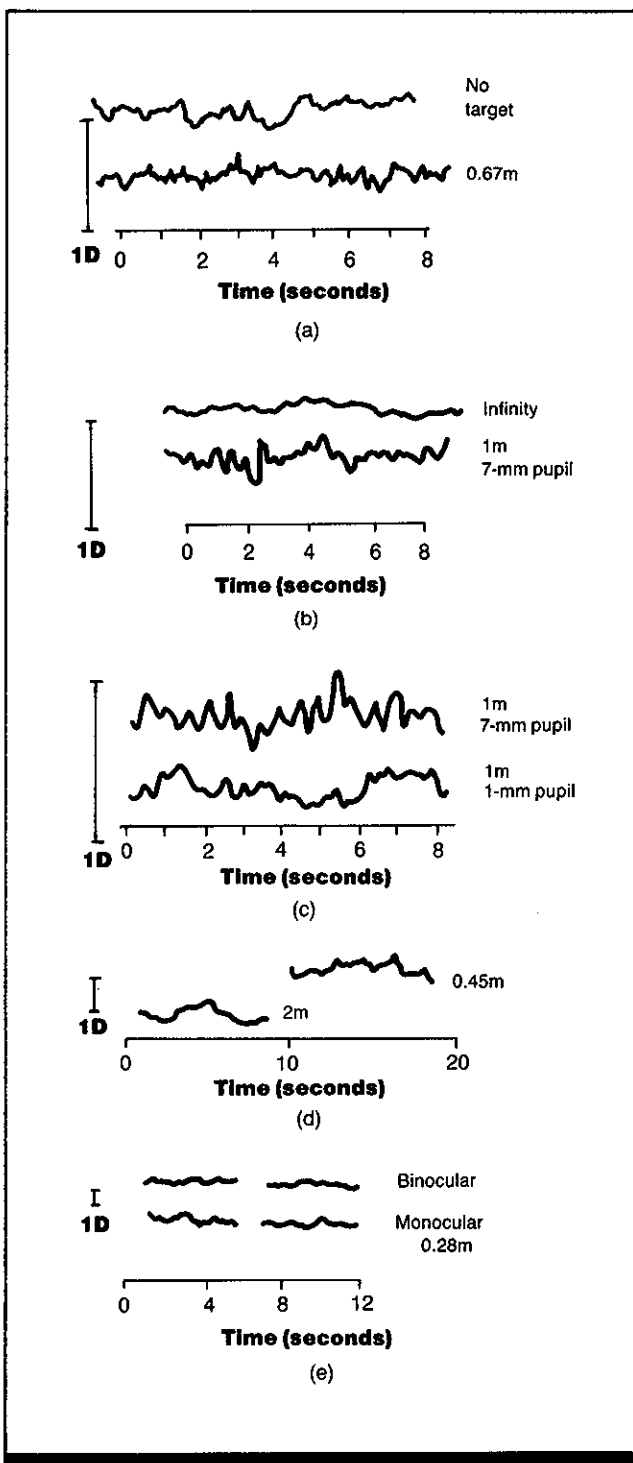

Variability

The range of fluctuations in accommodation was 0.2-0.5 diopters for 8 observers under the same conditions in one study.

Constraints

- Accommodation is affected by age.
- Accommodation is influenced by characteristics of the target stimulating accommodation, including luminance level, oscillatory and abrupt changes in target distance, and the structure of the stimulus field (CRefs. 1.226, 1.228, 1.229, 1.230).

Key References

- *1. Campbell, F. W., Robson, J. G., & Westheimer, G. (1959). Fluctuations of accommodation under steady viewing conditions. *Journal of Physiology (London)*, *145*, 579-594.
- *2. Campbell, F. W., Westheimer, G., & Robson, J. G. (1958). Significance of fluctuations of accommodation. *Journal of the Optical Society of America*, *48*, 669.
3. Farrell, R. J., & Booth, J. M. (1984). *Design handbook for imagery interpretation equipment*. Seattle, WA: Boeing Aerospace Co.
- *4. Krueger, H. (1973). An apparatus for continuous, objective measurement of refraction of the human eye. *Optica Acta*, *20*, 277-285.
- *5. Yoshida, T., & Watanabe, A. (1973). Control mechanism of the accommodation-vergence eye-movement system in human eyes (NHK Tech. Monograph 21). Tokyo: Nippon Hoso Kyokai, Japan Broadcasting Corp. Technical Research Lab. (NASA Rep. N73-30062)

Cross References

- 1.225 Normal variation in accommodation: similarity in the two eyes;
- 1.226 Visual accommodation: effect of luminance level and target structure;
- 1.228 Accommodation: effect of dark focus, luminance level, and target distance;
- 1.229 Accommodation: effect of oscillatory changes in target distance;
- 1.230 Accommodation: effect of abrupt changes in target distance

1.225 Normal Variation in Accommodation: Similarity in the Two Eyes

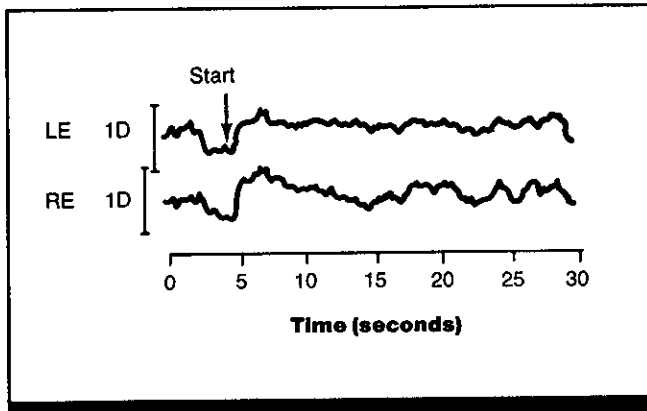

Figure 1. Amplitude of accommodation in the left eye (LE) and right eye (RE) as the observer tried to steadily fixate a target at a distance of 50 cm (2.0 diopters). Arrow indicates point at which steady fixation of the target began; bars on left show vertical distance corresponding to 1 diopter (D) of accommodation. (From Ref. 1)

Key Terms

Accommodation; eye focus; lens; refraction

General Description

Even when an observer attempts to maintain steady fixation on a target at a fixed distance, **accommodation** (eye focusing) fluctuates slightly, although target details appear to be in good focus. The variations in accommodation are very similar in the two eyes.

Methods

Test Conditions

- Small, high-contrast target at 50-cm viewing distance
- **Binocular** viewing
- Normal room illumination

Experimental Procedure

- Accommodation measured using double infrared optometer
- Observer's task: hold fixation on target as constant as possible
- One 22-year-old observer from whom results are given in Fig. 1 and 2 other observers

Experimental Results

- The fluctuations in accommodation that occur when an observer attempts to maintain fixation on a target at a given distance are similar in the left and right eyes.

Variability

No specific information on variability was given. The au-

thor reports that results similar to those in Fig. 1 were obtained with 2 other observers.

Repeatability/Comparison with Other Studies

The magnitude of the fluctuations in accommodation is similar to that found in other studies for monocular and binocular viewing (CRef. 1.224).

Constraints

- Accommodation is influenced by the age of the observer.
- Accommodation is influenced by characteristics of the target stimulating accommodation, including luminance

level, oscillatory and abrupt changes in target distance, and the structure of the stimulus field (CRefs. 1.226, 1.228, 1.229, 1.230).

- The amplitude of fluctuations in accommodation is affected by target distance and pupil size (CRef. 1.224).

Key References

*1. Campbell, F. W. (1960). Correlation of accommodation between the two eyes. *Journal of the Optical Society of America*, 50, 738.

Cross References

1.222 Visual accommodation;
 1.224 Normal variation in accommodation;
 1.226 Visual accommodation: effect of luminance level and target structure;

1.228 Accommodation: effect of dark focus, luminance level, and target distance;

1.229 Accommodation: effect of oscillatory changes in target distance;

1.230 Accommodation: effect of abrupt changes in target distance

1.226 Visual Accommodation: Effect of Luminance Level and Target Structure

Key Terms

Accommodation; eye focus; lens; refraction

General Description

The eyes change focus to resolve objects at different distances through a process known as accommodation, a change in the shape and thickness of the lens of the eye (CRef. 1.222). In general, the amplitude of accommodation matches target distance when the target is brightly lighted, detailed, and within arm's length (CRef. 1.231). Deviations from these optimal target characteristics produce inaccurate accommodation.

Methods

Test Conditions

Study 1 (Ref. 3)

- Targets were Snellen E or blank white wall, viewed without lenses or through lenses ranging from +1.0 diopter through -5.0 diopters in one-diopter steps
- Luminance level of .03 cd/m² or 685 cd/m²
- Refractive state assessed by modified stigmatoscope or infrared skiascope

Study 2 (Ref. 4)

- Targets were sinusoidal gratings of 65.4% contrast with spatial frequencies of 0.5, 1.2, 3.0, 4.9, 7.5, 9.8, or 19.2 c/deg; one high contrast square-wave grating of 4.3 c/deg; presented monocularly through a two-channel Maxwellian view optical system
- Mean target luminance was 262 cd/m²
- Accommodation measured with laser optometer (speckled interference pattern superimposed over fix-

ated stimulus appears to drift in a given direction depending on observer's refractive state)

- Depth of field controlled by dilating natural pupil; stimuli viewed through 3.5 mm artificial pupil

Experimental Procedure

Study 1

- Independent variables: power of lens (stimulus to accommodation), level of illumination, type of target
- Dependent variable: refractive state
- Observer's task: view targets
- 3 observers

Study 2

- Method of constant stimuli (for contrast threshold)
- Independent variable: power of lens (stimulus distance), spatial frequency of sine wave grating
- Dependent variable: accommodative responses
- Observer's task: focus targets without straining; close eyes and relax when targets appear to fade
- 2 observers

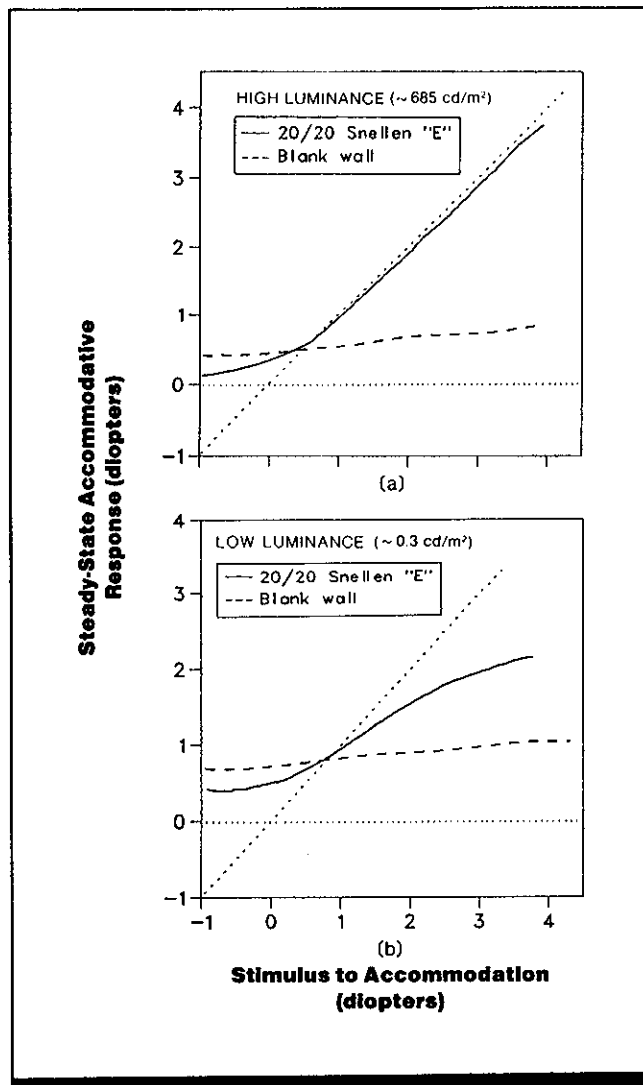

Figure 1. Accommodative response when viewing unstructured (dashed line) and detailed (solid line) visual stimuli at two luminance levels (Study 1). Dotted lines represent hypothetical, perfect responses. (From Handbook of perception and human performance, based on data from Ref. 3)

Experimental Results

- Focus errors are least likely when the target is detailed, within reach, and under high illumination.
- Accuracy of accommodation is greatest for a sine-wave grating of 3 c/deg. Accommodation accuracy of 3 c/deg is nearly identical to that obtained with the 4.3 c/deg square-wave target.
- Accuracy of accommodation falls off gradually at both higher and lower spatial frequencies.

Repeatability/Comparison with Other Studies

- Resting state of accommodation (as in complete darkness) has a mean of about 1.52 diopter (Ref. 2).
- Contours delineated only by chromatic differences and very high and very low spatial frequency patterns do not generate accurate accommodation responses (Refs. 1, 4, 5).

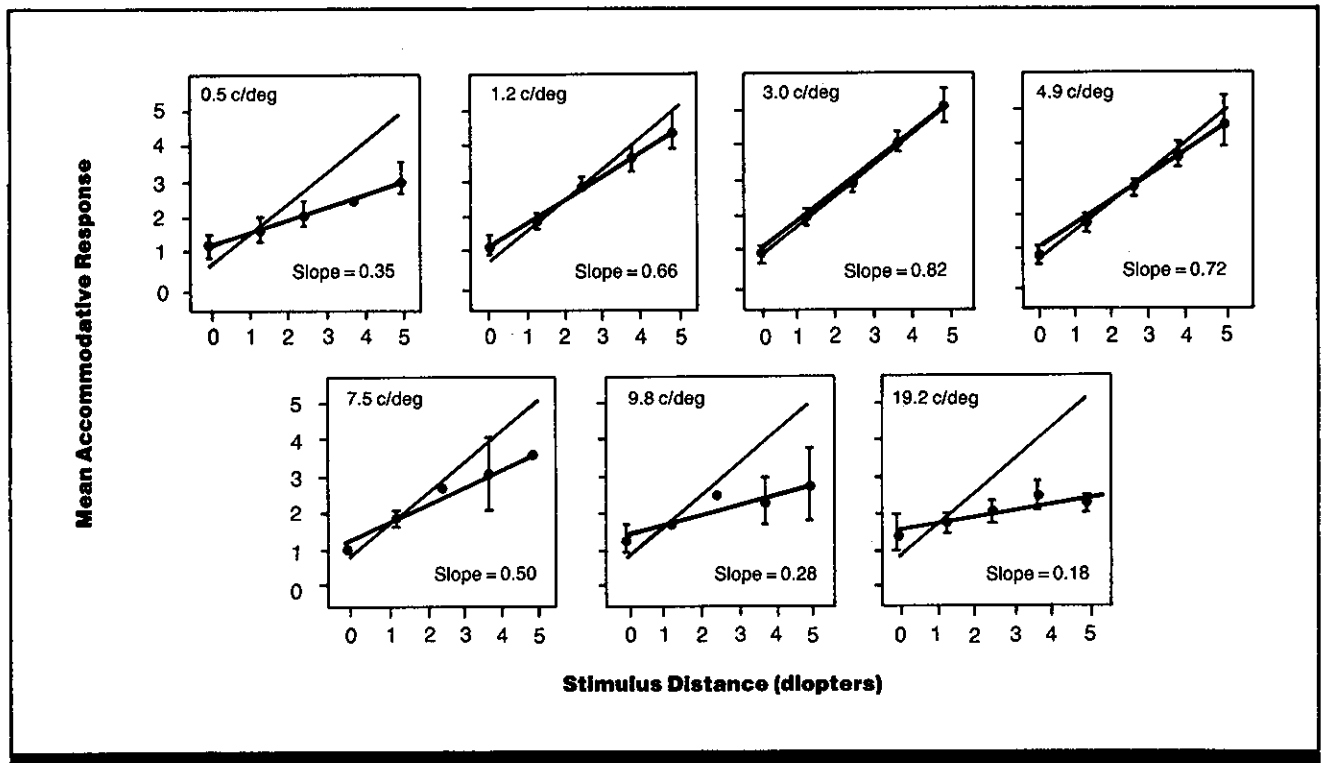

Figure 2. Mean accommodative responses as a function of spatial frequency and stimulus distance (Study 2). Solid functions are accommodative responses for a 4.3-Hz square-wave grating. (From Ref. 4)

Constraints

- Nearly all observers in these studies were young (college age). Accommodation is not as accurate in older observers, especially for near distances.
- Even when an observer is maintaining fixation on a target at a given distance, accommodation is not steady, but may fluctuate by as much as 0.5 diopters (CRef. 1.224).

Key References

1. Charman, W. N., & Tucker, J. (1977). Dependence of accommodation responses on the spatial frequency spectrum of the observed object. *Vision Research*, 17, 129-140.

2. Leibowitz, H. W., & Owens, D. A. (1978). New evidence for the intermediate position of relaxed accommodation. *Documenta Ophthalmologica*, 46, 133-147.

*3. Nadell, M. C., & Knoll, H. A. (1956). The effect of luminance, target configuration and lenses upon the refractive state of the eye. *American Journal of Optometry*, 33, 24-42.

*4. Owens, D. A. (1980). A comparison of accommodative responsiveness and contrast sensitivity for sinusoidal gratings. *Vision Research*, 20, 159-167.

5. Wolfe, J. M., & Owens, D. A. (1981). Is accommodation colorblind? Focusing chromatic contours. *Perception*, 10, 53-62.

Cross References

1.222 Visual accommodation;
1.224 Normal variation in accommodation;

1.227 Eye focus in dim illumination (night myopia);

1.229 Accommodation: effect of oscillatory changes in target distance;

1.230 Accommodation: effect of abrupt changes in target distance;

1.231 Relation between accommodation and convergence;

Handbook of perception and human performance, Ch. 4, Sect. 1.5

1.227 Eye Focus in Dim Illumination (Night Myopia)

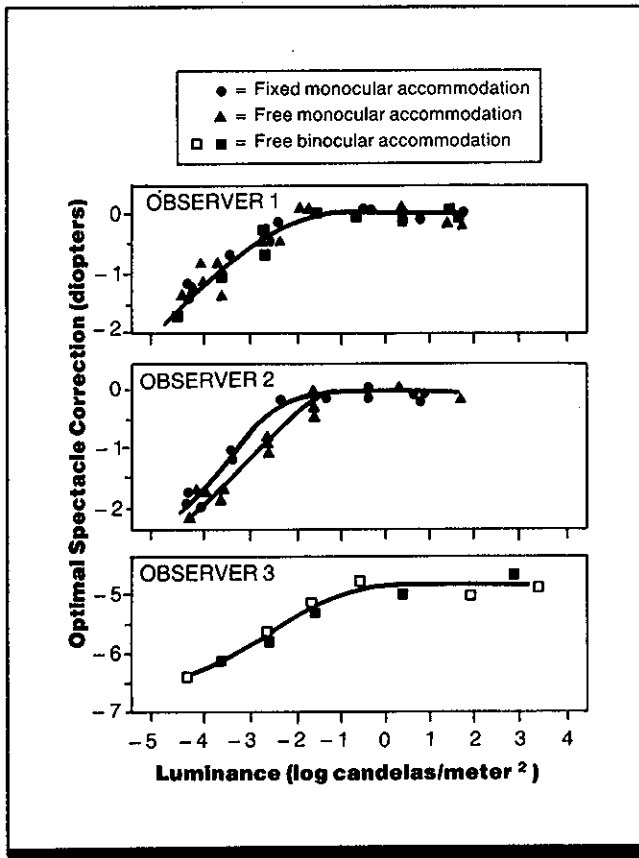

Figure 1. Myopia (refractive error) as a function of luminance level. Myopia (nearsightedness) is measured as the spectacle correction necessary for optimal resolution of a fine bar pattern. Observers 1 and 2 were emmetropic (needed no refractive correction); Observer 3 was myopic (note differences in scale of y-axis). The open and filled squares for Observer 3 are sets of data collected 2.5 yr apart. (From Ref. 2)

Key Terms

Accommodation; eye focus; nearsightedness; night myopia; night vision; refraction; scotopic vision; visual acuity

General Description

The eye becomes **nearsighted** (myopic) in dim light, starting at twilight levels of illumination and becoming increasingly myopic as the brightness is further reduced. The final level of myopia varies among individuals. The farthest distance

and the nearest distance at which an object can be focused approach each other. As light dims, it becomes more and more difficult for an observer to see clearly both distant and very near objects.

Applications

Detection or identification of distant objects in dim light.

Methods

Test Conditions

- 4-degree circular target consisting of square-wave grating pattern of alternate black and white bars of equal width; target could be turned to any orientation; bar-width size variable to cover range of visual acuities corresponding to luminance levels used

- White surround, 14 deg on a side, 6.1 m (20 ft) distant; luminances from 3.2×10^{-3} to 2.5×10^3 cd/m² (0.01-800,000 μ L), color temperature of illuminating sources (tungsten filament lamp) held at 2850° K

- Binocular or monocular viewing through phoropter apparatus (instrument providing a series of spectacle lenses of various powers

mounted on rotatable disks; lens power could be varied in 0.25 or 0.12 diopter steps); accommodation (eye focus) free or relaxed by appropriate fixation target

Experimental Procedure

- Independent variables: luminance of target and surround, monocular or binocular viewing, fixed or free accommodation
- Dependent variable: lens power at which smallest target was resolved

- Observer's task: to manipulate phoropter lenses to find the most positive and most negative power at which smaller and smaller bars could be resolved until negative and positive corrections were equal or only one or two lens powers apart; to verify resolution of bars, observer had to accurately identify orientation of bars set at several positions by the experimenter
- 3 observers with extensive practice

Experimental Results

- No myopia is observed at luminance levels above ~ 0.03 cd/m². Below this level, myopia increases (optimal spectacle correction becomes more and more negative) as the luminance decreases. Lens strength required is about -2 diopters at very low light levels for both emmetropic observers and even more negative for the myopic observer (Fig. 1).
- Results are similar whether viewing is monocular or binocular and whether accommodation is free or relaxed (i.e., stimulated for near or for far vision).

- In a related experiment, night myopia was found to occur even when a drug (homatropine) is used to prevent accommodation.

Variability

No specific information on variability was provided. Figure 1 shows good agreement among results for three different observers. Two series of measurements for Observer 3 made 2.5 yrs apart were in close agreement.

Constraints

- Magnitude of night myopia may vary somewhat depending on the size, contrast, and surround of the object viewed.
- Accommodation (eye focus) is affected by the age of the observer.

Key References

1. Johnson, C. A. (1976). Effects of luminance and stimulus distance on accommodation and visual resolution. *Journal of the Optical Society of America*, 66, 138-142.

*2. Koomen, M., Scolnik, R., & Tousey, R. (1951). A study of night myopia. *Journal of the Optical Society of America*, 41, 80-90.

3. Leibowitz, H. W., & Owens, D. A. (1975). Night myopia and the intermediate dark focus of accommodation. *Journal of the Optical Society of America*, 65, 1121-1128.

Cross References

1.222 Visual accommodation;

1.223 Resting position of accommodation;

1.228 Accommodation: effect of dark focus, luminance level, and target distance

1.228 Accommodation: Effect of Dark Focus, Luminance Level, and Target Distance

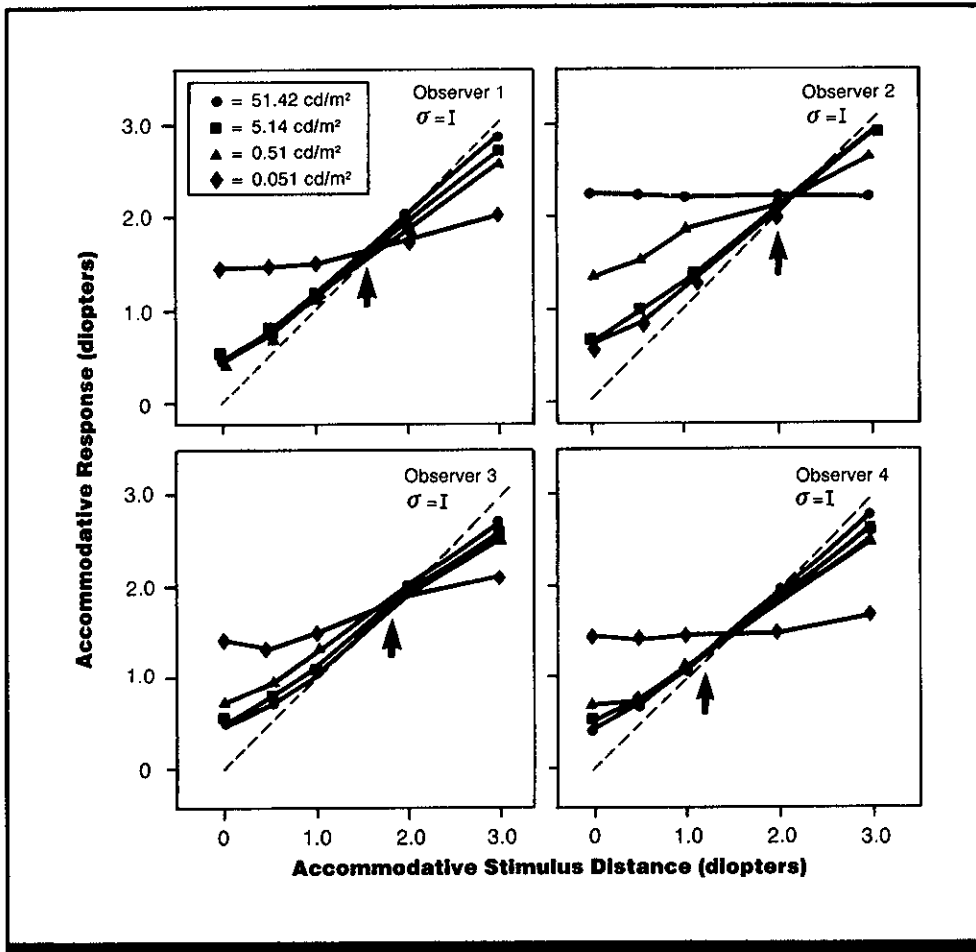

Figure 1. Accommodative response as a function of target distance at four luminance levels. Dashed line represents direct one-to-one correspondence between target distance and accommodative response (i.e., "perfect" accommodation). Solid arrows indicate mean dark focus (amplitude of accommodation). Error bars at top right of each panel show one standard deviation. Note that diopters equal the reciprocal of distance in meters; thus, target distance decreases from left to right along the abscissa. (From Ref. 3)

Key Terms

Accommodation; dark focus; eye focus; lens; luminance; night myopia; refraction; resting accommodation; viewing distance

General Description

The amplitude of accommodation (eye focusing) to a visual target is affected by target distance, luminance level, and target location relative to an observer's individual dark focus (distance to which the observer is accommodated in total darkness). Observers show an overaccommodation to

far targets and an underaccommodation to near ones. Error of accommodation decreases with increases in overall luminance. Accuracy of accommodation is greatest when targets are located near the dark-focus distance.

Applications

Observer selection criteria for target detection or discrimination tasks should take into account the relationship between observer's dark focus and task demands. Display designs and viewing conditions should allow for effects of variability in accommodation.

Methods

Test Conditions

- Ten-deg circular surround with diagonal crosshairs and centered annulus (2-deg inner diameter, 3-deg outer diameter) to aid fixation and accommodation
- Stimulus displays at five optical distances from 0-3.0 diopters (corresponding to targets located at optical infinity and at distances of 0.33-2m)

- Surround field luminance varied from 0.05 to 51.4 cd/m²
- For accommodation measurements, 2-deg circular laser speckle pattern was superimposed on surround field; pattern duration of 500 msec per trial
- Surround field presented in Maxwellian view
- Light-tight booth with bite-bar and headrest to control viewing distance; right eye occluded

Experimental Procedure

- Accommodation measured using laser optometer
- Observer dark-adapted 10 min at start of session, followed by 5 min adaptation to surround field luminance; dark focus determined at beginning and end of each session
- Independent variables: optical distance of stimuli, surround-field luminance

- Dependent variables: accommodative response as measured by optical distance (in diopters) of laser speckle pattern at which pattern appeared motionless
- Observer's task: report verbally the direction of motion (up or down) of speckle pattern until pattern perceived as motionless or swirling
- 4 observers, highly practiced, ages 22-24, with normal or better acuity

Experimental Results

- Dark focus (accommodation distance in the dark) varies between 1.0 and 2.25 diopters among observers.
- The range of accommodation decreases as luminance level decreases. At the lowest luminance level used (0.051 cd/m²), accommodation (focus distance) varies by only 0.5 diopter or less as target distance changes from 0.5 to 3.0 diopters.
- Error of accommodation increases with increasing distance of target from the observer's dark focus.
- Observers overaccommodate to targets located farther than the dark-focus distance and underaccommodate to targets located nearer than dark focus.

- Accommodative error increases with decreasing luminance.

Variability

Error bars for one standard deviation shown on Fig. 1.

Repeatability/Comparison with Other Studies

Results are consistent with many earlier studies which also found overaccommodation to far targets and underaccommodation to near ones. The dark focus values obtained in this study are consistent with those obtained in studies of large population samples (Ref. 4).

Constraints

- Dark focus position varies with age and visual acuity (Ref. 4).
- The magnitude of accommodation is influenced by the observer's age (CRef. 1.222).

- Accommodation is influenced by a number of target characteristics (CRefs. 1.226, 1.229, 1.230).
- Even when an observer is maintaining fixation on a target at a given distance, accommodation is not steady but may fluctuate by as much as 0.5 diopters (CRef. 1.224).

Key References

1. Alpern, M. (1958). Variability of accommodation during steady fixation at various levels of illuminance. *Journal of the Optical Society of America*, 48, 193-197.

2. Charman, W. N., & Tucker, J. (1977). Dependence of accommodation response on the spatial frequency spectrum of the observed object. *Vision Research*, 17, 129-139.

*3. Johnson, C. A. (1976). Effects of luminance and stimulus distance on accommodation and visual resolution. *Journal of the Optical Society of America*, 66, 138-142.

4. Simonelli, N. M. (1983). The dark focus of the human eye and its relationship to age and visual defect. *Human Factors*, 25, 85-92.

Cross References

1.222 Visual accommodation;

1.224 Normal variation in accommodation;

1.226 Visual accommodation: effect of luminance level and target structure;

1.229 Accommodation: effect of oscillatory changes in target distance;

1.230 Accommodation: effect of abrupt changes in target distance

1.229 Accommodation: Effect of Oscillatory Changes in Target Distance

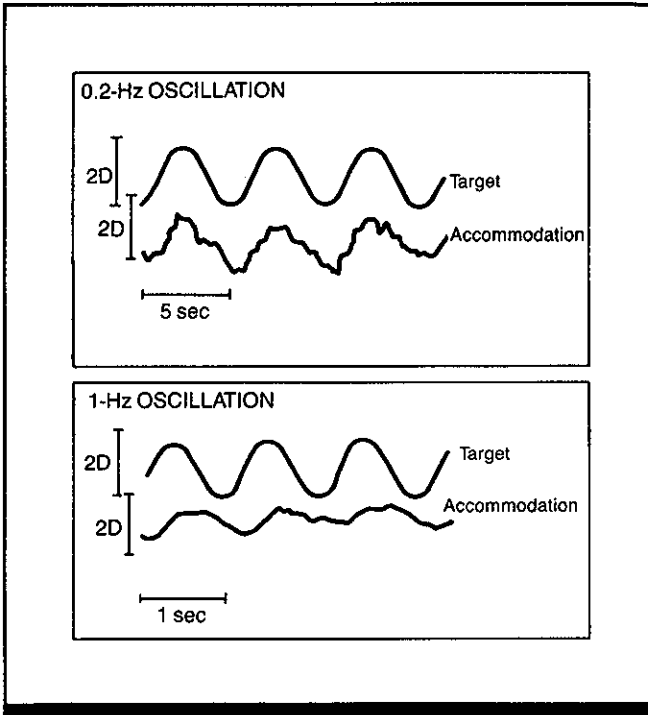

Figure 1. Accommodative responses to oscillations in target distance of 1.7 diopters (0.59 m) centered at 1.36 diopters (0.74 m) at two oscillation frequencies. (From Ref. 3)

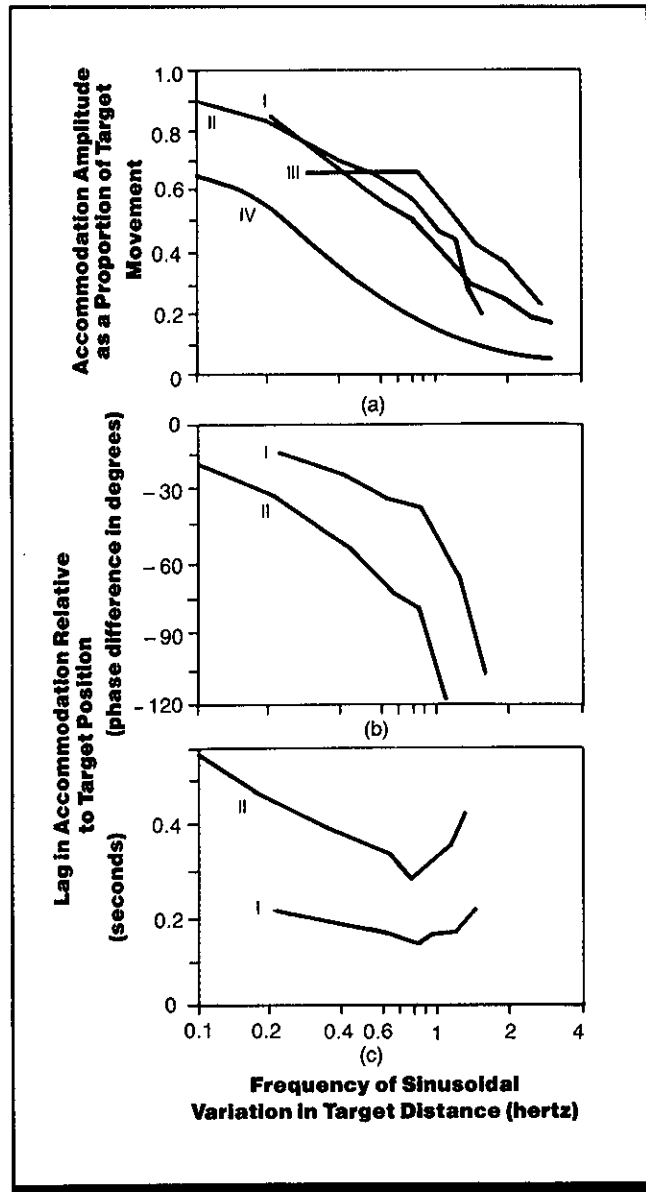

Figure 2. Accommodation as a function of frequency of oscillation in target distance. Figure shows results from four studies. (a) Amplitude of accommodation as a proportion of target movement (value of 1.0 on ordinate indicates accommodative response that compensates completely for target movement); (b) phase lag in degrees between accommodative response and target oscillation; and (c) temporal lag of accommodative response. (Adapted from data in Refs. 1, 2, 4, & 5)

Key Terms

Accommodation; eye focus; lens; motion in depth; refraction; viewing distance; visual tracking

General Description

Observers have difficulty maintaining eye focus (**accommodation**) for a distant target that is oscillating in depth. As oscillation frequency increases, the relative amplitude of accommodation decreases and the accommodative response tends to lag further behind the target position.

Methods (across studies)

Test Conditions

- High-contrast targets (disks or bar patterns) on a white surround, illuminated up to 80 cd/m², either moving **sinusoidally** in depth or made to appear to move by manipulating stereoscopic display

- Amplitude of target oscillation 0.6-3 diopters (corresponding to distances of 0.33-167 m)
- **Monocular** and **binocular** viewing with real movement; binocular viewing with stereoscopic presentation
- Pupils often dilated with drugs

Experimental Procedure

- Independent variables: frequency and amplitude of target oscillation, mean target distance
- Dependent variables: amplitude, frequency, and response time of accommodation

- Observer's task: to maintain target in focus
- Several observers usually tested, but only the data for one "typical" observer is presented

Experimental Results

- As the frequency of target oscillation in depth increases, the relative amplitude of the accommodative response decreases (Fig. 1). The decrease is greater for monocular than for binocular viewing.
- As oscillation frequency increases, the accommodative response lags further behind the target position.

Variability

Reaction time to a single change in a focusing stimulus varies by 0.27-0.46 sec among 6 observers; amplitude of accommodation varies from 2-7% for a given observer. Curves III and IV in Fig. 2 show a striking difference in measurements apparently under similar conditions.

Constraints

- Results may be affected by the mean level of accommodation.
- Age affects the results.
- Very few observers have been tested.
- Experimental methods are often described only briefly.

Key References

*1. Campbell, F. W., Robson J. G., & Westheimer, G. (1959). Fluctuations of accommodation under steady viewing conditions. *Journal of Physiology* (London), *145*, 579-594.

*2. Campbell, F. W., & Westheimer, G. (1960). Dynamics of accommodation responses of the

human eye. *Journal of Physiology* (London), *151*, 285-295.

3. Farrell, R. J., & Booth, J. M. (1984). *Design handbook for imagery interpretation equipment*. Seattle, WA: Boeing Aerospace Co.

*4. Krueger, H. (1973). An apparatus for continuous, objective measurement of refraction of the

human eye. *Optica Acta*, *20*, 277-285.

*5. Yoshida, T., & Watanabe, A. (1973). *Control mechanism of the accommodation-vergence eye-movement system in human eyes* (NHK Tech. Monograph 21). Tokyo: Nippon Hoso Kyokai, Japan Broadcasting Corp. Technical Research Lab. (NASA Rep. N73-30062)

Cross References

1.222 Visual accommodation;

1.223 Resting position of accommodation;

1.225 Normal variation in accommodation: similarity in the two eyes

1.230 Accommodation: Effect of Abrupt Changes in Target Distance

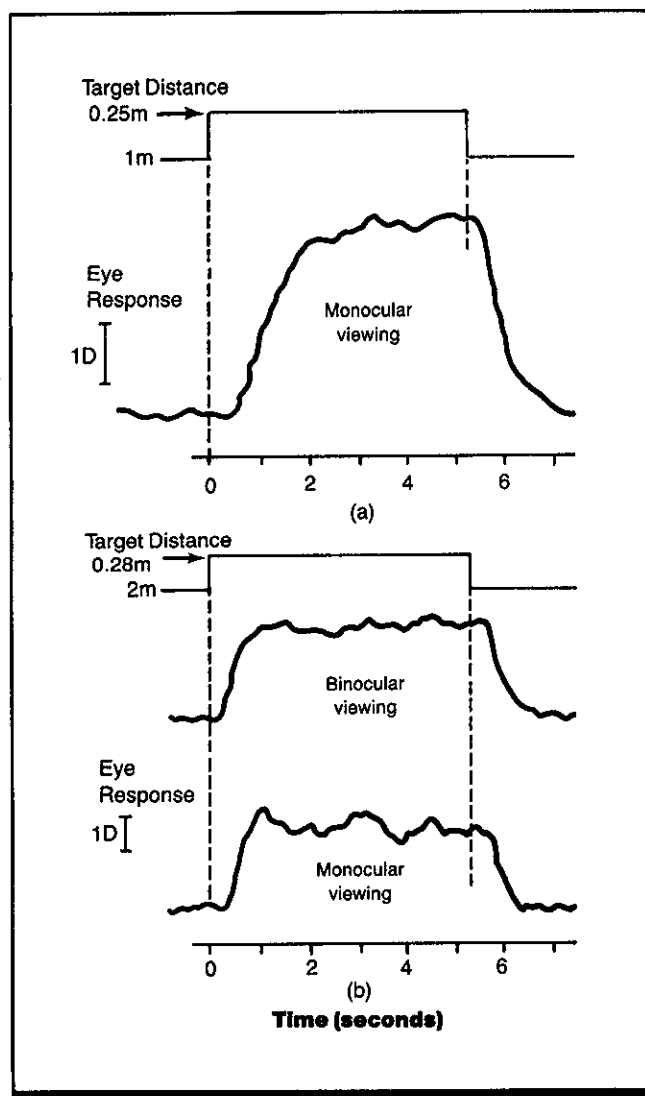

Figure 1. Accommodative responses to a sudden change in target distance (a) from 1 m to 0.25 m (1 to 4 diopters). (From Ref. 4) (b) from 2 m to 0.28 m (0.5 to 3.5 diopters). (From Ref. 3) Top of each panel shows change in target distance; bottom shows associated accommodative response. Bars indicate vertical distance corresponding to 1 diopter (D). Each panel shows results for one subject.

Key Terms

Accommodation; eye focus; lens; monocular viewing; refraction; viewing distance

General Description

The eye does not respond immediately to a sudden change in target distance. It takes time for the eye to begin to change its focus and additional time to complete the change.

Methods**Test Conditions**

- Small, high-contrast target
- Surround luminance ranged from very dim to ~ 35 cd/m²
- Target distance from 0.22-2 m, with target moving along optical axis of the eye

- Monocular and binocular viewing
- Pupils dilated to >4 -5 mm through test conditions (luminance level) or drugs

Experimental Procedure

- Independent variable: magnitude of change of target distance

- Dependent variables: latency, duration, and accuracy of accommodative response
- Observer's task: maintain target in focus
- 5 trained observers in Ref. 3, ages 24-40; number of observers not specified in Ref. 4

Experimental Results

- Accommodative response (eye focus response) begins ~ 0.4 sec after a change in target distance.
- Once accommodation is initiated, it takes ~ 0.6 sec to complete the accommodative change.
- The ratio of accommodative distance to target distance was 83-90% for the younger observers and 62% for the 40-yr-old observer (i.e., accommodation did not compensate completely for the change in target distance).

- Binocular viewing results in greater accommodative accuracy than monocular viewing.
- Results are similar for target changes from near to far distances and from far to near.

Variability

Time to initiate accommodation varied from 0.27-0.46 sec for 6 observers; amplitude of accommodation varied from 2-7% for a given observer.

Constraints

- The age of the observer affects accommodation.
- Results may be affected by the mean level of accommodation about which the change occurs.

- Accommodation is influenced by characteristics of the target stimulating accommodation, including luminance level, oscillatory and abrupt changes in target distance, and the structure of the stimulus field (CRefs. 1.226, 1.228, 1.229).

Key References

1. Campbell, F. W., & Westheimer, G. (1960). Dynamics of accommodation responses of the human eye. *Journal of Physiology* (London), *151*, 285-295.

2. Farrell, R. J., & Booth, J. M. (1984). *Design handbook for imagery interpretation equipment*. Seattle, WA: Boeing Aerospace Co.

*3. Krueger, H. (1973). An apparatus for continuous, objective measurement of refraction of the human eye. *Optica Acta*, *20*, 277-285.

*4. van der Wildt, G. J., & Bouman, M. A. (1971). An accommodometer: An apparatus for measuring the total accommodation response of the human eye. *Applied Optics*, *10*, 1950-1958.

5. Yoshida, T., & Watanabe, A. (1973). *Control mechanism of the accommodation-vergence eye-movement system in human eyes* (NHK Tech. Monograph 21). Tokyo: Nippon Hoso Kyokai, Japan Broadcasting Corp., Technical Research Lab. (NASA Rep. N73-30062).

Cross References

1.222 Visual accommodation;

1.224 Normal variation in accommodation;

1.226 Visual accommodation: effect of luminance level and target structure;

1.228 Accommodation: effect of dark focus, luminance level, and target distance;

1.229 Accommodation: effect of oscillatory changes in target distance

1.231 Relation Between Accommodation and Convergence

Key Terms

AC/A ratio; accommodation; convergence; eye focus; lens; refraction; single vision; vergence eye movements; viewing distance

General Description

With normal vision, a change in fixation from far to near involves **convergent** eye movements to cause the eyes' lines of sight to intersect at the new target distance, a change in eye focus (**accommodation**), and a contraction of the pupils; these three changes facilitate clear binocular vision at close range. In the absence of any changes in the stimulus for accommodation, changes in convergence produce changes in accommodation. Similarly, changes in accommodation are accompanied by changes in convergence in both **monocular** and binocular viewing. If one eye is covered, the covered eye makes a clear inward (or convergent) motion when accommodation is increased and makes an outward (or divergent) motion when accommodation is relaxed.

The change in accommodative vergence (in prism diopters) per unit change in accommodation (in diopters) is the AC/A ratio. The ratio called for by the stimulus conditions is termed the stimulus AC/A ratio; the actual response is the response AC/A ratio. The average response AC/A ratio is ~ 1.08 times the stimulus AC/A ratio (Ref. 1). The ratio for an individual is remarkably constant, even with refractive correction, and does not change with age. The ratios for different people vary over a wide range. However, in the general population, individual AC/A ratios vary between 3 and 5 diopters per diopter of accommodation. Typically, there is ~ 1.76 deg change in phoria (angle between the lines of sight of the eyes in the absence of a fusion target), for each diopter change in accommodation. Most visually normal people have AC/A ratios just a little larger than one-half of their interocular (interpupillary) separation. Thus there is a fairly large **exophoria** (divergence) at reading distances. This deficit in convergence is made up for by fusion in the central nervous system: within limits, the two retinal images will still be seen as single even when they do not fall upon exactly corresponding points of the retinas. A moderate amount of near phoria thus causes no discomfort, image blurring, or double vision. When the required phoria equals or exceeds the fusional reserve or fusional buffer between accommodation and convergence, binocular vision may be present but uncomfortable, or monocular vision may take over with vision remaining comfortable because the image of one eye is suppressed.

The Donders or demand line shown in Fig. 1 represents the amount of accommodation and convergence (measured in diopters and meter angles, respectively) required for symmetrical convergence on a target object that is moved toward the observer along the midline. A meter angle is the angle subtended by the baseline connecting the centers of rotation of the two eyes at a perpendicular distance of one meter from the middle of this line (i.e., the angular convergence required for fixation of a target on the median line 1 m

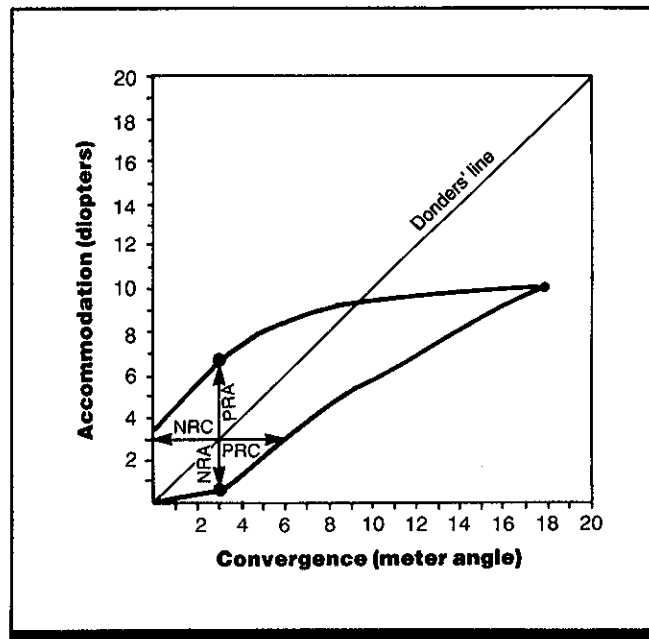

Figure 1. The relation between accommodation and convergence. The heavy line shows the region within which single binocular vision can be maintained (i.e., without double images). PRA and NRA are the positive and negative relative accommodation, respectively; PRC and NRC are the positive and negative relative convergence, respectively. Donders' line indicates the values required for symmetrical convergence on a target that is moved toward the observer along the midline. (From Ref. 2)

from the centers of rotation of the eyes). The large meter angle, which is the sum of the rotations for both eyes, is usually used. The small meter angle is for one eye only. The amount of eye convergence required for fixation at a given distance can be specified in diopters by multiplying the meter angle by the interocular separation in centimeters. Both meter angles and diopters give required eye position, but actual convergence will be different from a perfect position.

Figure 1 shows the relation between accommodation and convergence. The heavy lines enclose the zone of single binocular vision, that is, the zone within which binocular vision can be maintained without double images. The relative ranges of accommodation are from early measurements obtained by determining the strongest minus and plus spherical lenses (stimulating positive and negative accommodations, respectively) that could be tolerated by the observer without destroying single binocular vision for various distances in the median plane (i.e., directly in front of the observer). The ranges of relative convergence were added by a later researcher (see Ref. 2). PRA and NRA are the positive and negative relative accommodation, and PRC and NRC are the positive and negative relative convergence. Reference 3 defined the zone of comfort as the middle third of the range between positive and negative relative convergence (i.e., the middle third of the zone of clear single vision).

Reference 4 recommended that the distance from the Donders or demand line to the limit of fusional vergence be called the fusional "reserve," and that this reserve be no less than twice the demand value to allow comfortable vision. These two rules yield similar results in most cases.

When binocular instruments are used, the eyes usually cover more than required by optical conditions, even when

the instrument focus is set to form a distant image. This is probably due to awareness of the apparent nearness of the viewed object of scene because of the angularly large size of both viewed objects and details. Instrument users also tend to adjust the focus of binocular eyepieces to negative, often very negative, diopter values even though their vision is not myopic (nearsighted).

Applications

Design of binocular instruments; divergence and convergence limits for distortion in vehicle windscreens.

Constraints

- Individual differences in tolerance to mismatch of accommodation and convergence are large; individuals usually have some phoria that may appreciably influence their tolerances.

Key References

1. Alpern, M., Kincaid, W. M., & Lubeck, M. J. (1959). Vergence and accommodation. III. Proposed definitions of the AC/A ratios.

American Journal of Ophthalmology, 43, 141-148.

2. Michaels, D. D. (1975). *Visual optics and refraction. A clinical approach*. St. Louis, MO: C. V. Mosby.

3. Percival, A. S. (1892). The relation of convergence to accommodation and its practical bearing. *Ophthalmology Review*, 11, 313-328.

4. Sheard, C. (1930). The zone of ocular comfort. *American Journal of Ophthalmology*, 7, 9-25.

Cross References

1.222 Visual accommodation;
1.223 Resting position of accommodation;

1.224 Normal variation in accommodation;
1.808 Convergence angle;
1.809 Phoria

1.232 Monocular Versus Binocular Pupil Size

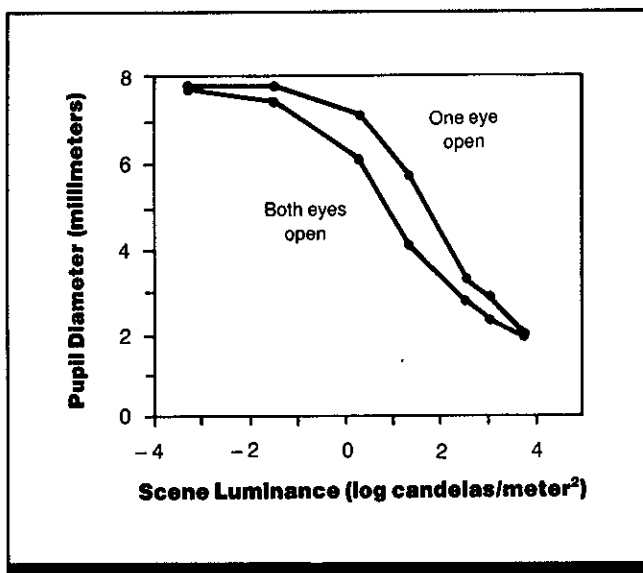

Figure 1. Average monocular and binocular pupil diameter as a function of luminance level. (From Ref. 2)

Key Terms

Dark adaptation; light adaptation; monocular viewing; pupil size; pupillary reflex

General Description

The diameter of the pupil of the eye is less when both eyes are illuminated than when only one is illuminated; pupil diameter decreases with increasing illumination.

Applications

Calculation of retinal illuminances.

Methods

Test Conditions

- Luminance from total darkness to 7000 cd/m²
- Observer adapted to given light level, then eye photographed with mm scale placed in plane of pupil

Experimental Procedure

- Independent variables: field luminance, monocular or binocular viewing
- Dependent variable: pupil diameter
- Observer's task: maintain constant fixation
- 2-6 observers

Experimental Results

- Pupil diameter decreases as light level increases.
- Decrease is greater when both eyes are stimulated, except at very low and very high light levels.

Variability

The difference in pupil diameters between the two observers ranged from 0.1-1.7 for binocular viewing and from 0.0-1.3 for monocular viewing. The larger differences were

at the four lowest luminances; for the four highest luminances, the differences were 0.1-0.3 and 0.0-0.2, respectively.

Repeatability/Comparison with Other Studies

The relation between pupil size and luminance level is consistent with that found in a large number of studies (CRef. 1.233).

Constraints

- Age may affect the results.
- Pupil size may be affected by such factors as the color of the target, target distance, eye color, sex, refractive error of the eyes, and the structure of the visual field (CRef. 1.234).
- Pupil size varies considerably from one person to the next at a given luminance level.

Key References

1. Farrell, R. J., & Booth, J. M. (1984). *Design handbook for imagery interpretation equipment*. Seattle, WA: Boeing Aerospace Co.
- *2. Reeves, P. (1918). Rate of pupillary dilation and contraction. *Psychological Review*, 25, 330-340.

Cross References

- 1.233 Pupil size: effect of luminance level;
- 1.234 Pupil size: effect of target distance

1.233 Pupil Size: Effect of Luminance Level

Key Terms

Dark adaptation; light adaptation; pupil size; pupillary reflex

General Description

Pupil size varies with the level of illumination (Fig. 1). The pupil constricts in bright light and dilates in dim light, but these changes are not monotonic. When the light is suddenly increased (Fig. 2a), the pupil first constricts and then dilates (i.e., it overcompensates), after which it may constrict again. When the light is suddenly dimmed (Fig. 2b), the pupil dilates and then constricts, then dilates again. The time it takes the pupil to stabilize is related roughly to the time it takes for **dark adaptation** and **light adaptation** of the eye. Constriction occurs in less than a minute, but complete dilation may take ~20 min (Fig. 3).

Applications

Calculation of retinal illuminance.

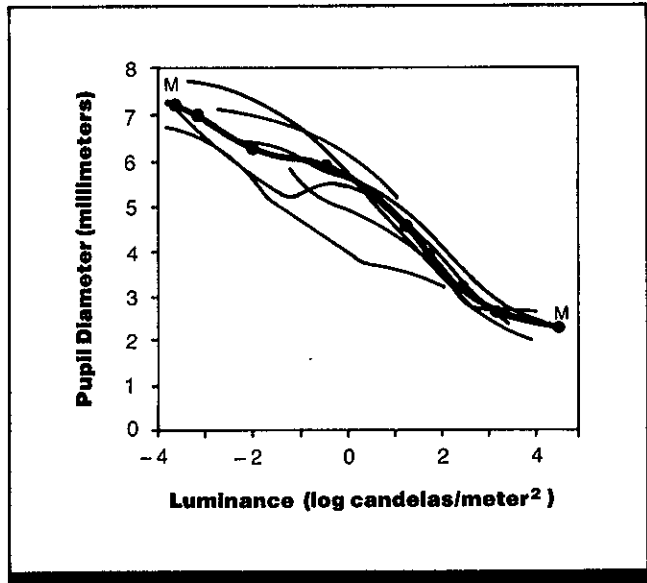

Figure 1. Pupil size as a function of luminance level. Unlabeled curves are for six studies summarized in Ref. 4 (see Ref. 4 for details). Curve M (with data points) is the mean across all studies, weighted by the number of observers in each study. (From Ref. 4)

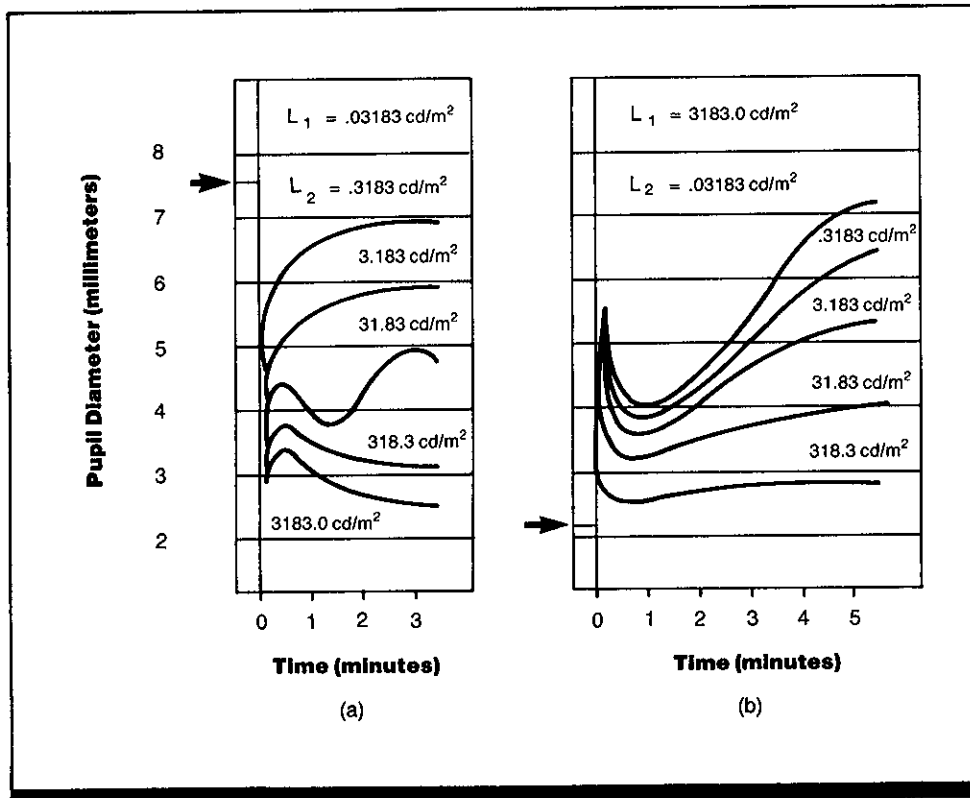

Figure 2. Fluctuations in pupil size when light is (a) increased and (b) decreased in steps of one log unit. The arrows point to the pupil diameter in the initial illumination. Initial luminance level, designated as L_1 , was .03183 and 3183 cd/m² (0.1 and 10,000 apostilbs) for panels (a) and (b), respectively; L_2 designates the luminance level after the first increment or decrement. (From Ref. 3)

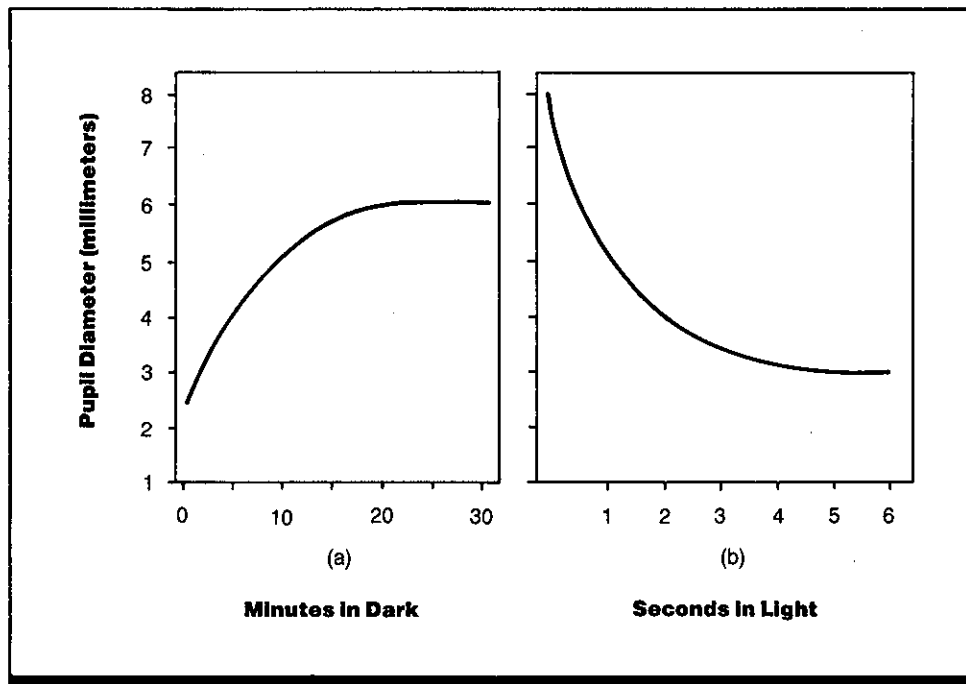

Figure 3. Time required for the pupil (a) to fully dilate in total darkness following 3 min centrally fixated exposure to bright (4.0×10^6 trolands) 40% field. (From *Handbook of perception and human performance*.) (b) To fully constrict after exposure to a 100 ml (318.3 cd/m^2) lights. No dark adaptation duration was given. (Note difference in time scales on abscissa for panels [a] and [b]). (From Ref. 5)

Methods (across studies)

Test Conditions

- White light; luminance 10^{-3} - 10^4 cd/m^2

- Field sizes between 25 and 180 deg of visual angle
- Usually one eye illuminated and other eye photographed

Experimental Procedure

- Independent variables: field luminance, monocular versus binocular stimulation

- Dependent variable: pupil diameter
- Observer's task: maintain fixation on target field
- 5-52 observers per study

Experimental Results

- Pupil diameter decreases as luminance level increases.
- Pupil diameter varies between 2 and 8 mm, depending on luminance level.
- The change in pupil size is not a smooth function over time.

- The pupil takes up to 20 min to dilate fully, but <1 min to constrict.

Variability

Pupil size for a given individual varies by ~10% under the same conditions. The variability between individuals may be as great as 3 mm, 50% of the entire range.

Constraints

- Pupil diameter is smaller when both eyes are stimulated (CRef. 1.232).
- Age greatly affects pupil mobility.
- Pupil size may be affected by such factors as the color of

the target, target distance, eye color, sex, refractive error of the eyes, and the structure of the visual field (CRef. 1.234).

- Pupil size varies considerably from one person to the next at a given luminance level.

Key References

- *1. Alpern, M., & Campbell, F. W. (1963). The behavior of the pupil during dark-adaptation. *Journal of Physiology* (London), 165, 5-7.
2. deGroot, S. H., & Gebhard, J. W. (1952). Pupil size as determined by adapting luminance. *Journal of the Optical Society of America*, 42, 492-495.

*3. Hornung, J. (1967). Pupillenbewegungen nach einem Sprung der Reizlichtintensität (Pupillary movements after a jump in the intensity of the stimulus light). *Pflugers Archiv*, 296, 39-48.

*4. Mellerio, J. (1966). Ocular refraction at low illuminations. *Vision Research*, 6, 217-237.

*5. Reeves, P. (1918). Rate of pupillary dilation and contraction. *Psychological Review*, 25, 330-340.

6. ten Doesschate, J., & Alpern, M. (1967). Effect of photoexcitation of the two retinas on pupil size. *Journal of Neurophysiology*, 30, 562-576.

Cross References

1.232 Monocular versus binocular pupil size;

1.234 Pupil size: effect of target distance;

Handbook of perception and human performance, Ch. 4, Sect. 1.12

1.234 Pupil Size: Effect of Target Distance

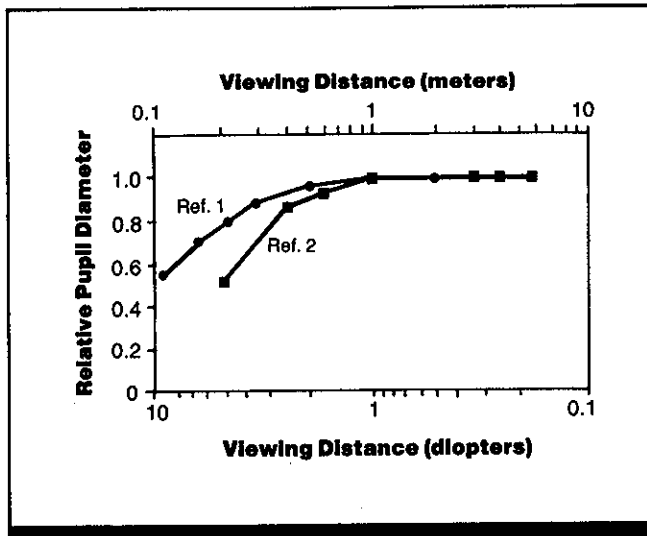

Figure 1. Relative pupil diameter as a function of target distance. (The upper line is based on data in Ref. 1; the lower line is from Ref. 2.) Pupil size at a given viewing distance is shown as a proportion of pupil size at the maximum distance used (Ref. 1) or at infinity (Ref. 2).

Key Terms

Pupil size; pupillary reflex; viewing distance

General Description

The diameter of the pupil decreases as target distance is reduced below 1 m.

Applications

Calculation of retinal illuminance.

Methods

Test Conditions

- Fixation distances from 0.1-10 m
- Field luminances from 30-475 cd/m²

Experimental Procedure

- Independent variables: distance of target, luminance level
- Dependent variable: pupil diameter

- Observer's task: fixate a high-contrast target
- 3 observers, mean age 38 (Ref. 2); 1 observer (Ref. 1)

Experimental Results

- Pupil diameter decreases to a minimum of about one-half its maximum diameter as fixation distance is reduced below 1 m.
- Results are the same for field luminances from 30-475 cd/m².

Variability

Reference 1 provided results of three determinations at each target distance; pupil diameter varied by 0.9 mm at the target distance of 15 cm, which was one-third the total range of pupil constriction. Figure 1 shows that there is considerable variability among subjects in different experiments.

Constraints

- Only intermediate field luminances have been used.
- Age may affect the results.
- Pupil size may be affected by such factors as the color of

the target, target distance, eye color, sex, refractive error of the eyes, and the structure of the visual field (CRef. 1219).

- Pupil size varies considerably from one person to the next at a given luminance level.
-

Key References

*1. Alpern, M., Ellen, P., & Goldsmith, R. I. (1958). The electrical response of the human eye in far-to-near accommodation. *Archives of Ophthalmology*, 60, 592-602.

*2. Bartleson, C. J. (1968). Pupil diameters and retinal illuminances in interocular brightness matching. *Journal of the Optical Society of America*, 58, 853-855.

Cross References

1.232 Monocular versus binocular pupil size;

1.233 Pupil size: effect of luminance level;

1.234 Pupil size: effect of target distance

1.235 The Normal Achromatic Visual Field

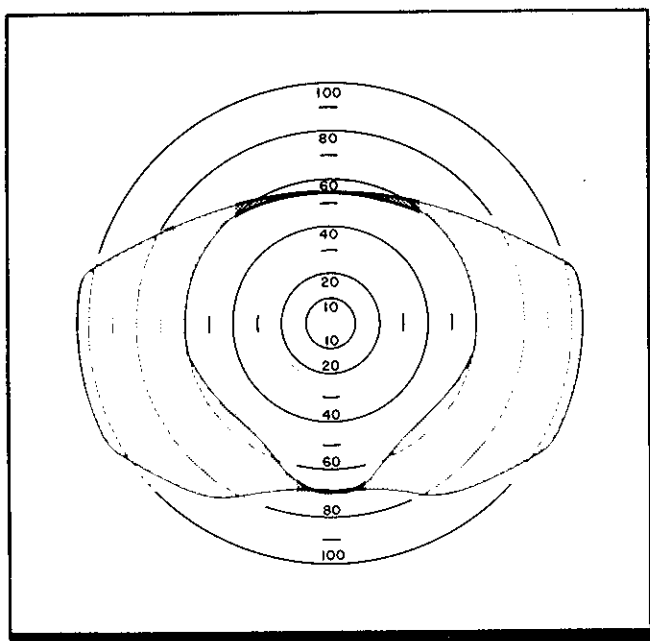

Figure 1. The normal achromatic binocular visual field (in degrees of visual angle). The shaded portions are visible to only one eye. (Based on data from Refs. 1, 4)

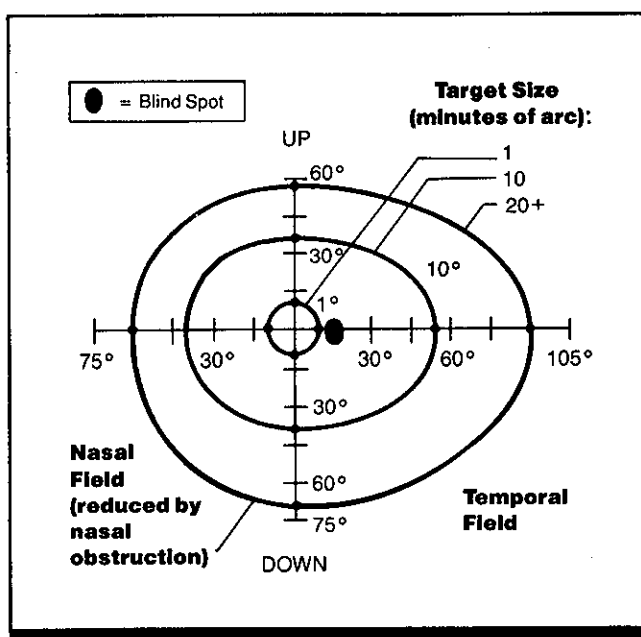

Figure 2. The normal achromatic monocular visual field for targets of various sizes. The figure is for the right eye; the left eye's field is a mirror image of that for the right eye. (From Ref. 3, plotted from data in Ref. 1)

Key Terms

Field of view; perimetry; peripheral vision; visual field

General Description

The maximum field of view of the normal observer for achromatic targets (Fig. 1) is a somewhat irregularly shaped ellipse made up of the overlapping monocular fields of the right and left eyes. It extends ~60 deg of visual angle above and below the center and more than 100 deg to the sides.

The field of view is reduced by any variable (such as luminance, contrast, or size) that reduces the visibility of the target. Figure 2 shows the reductions in the visual field that occur when the target is reduced in size.

Applications

Displays or environments requiring that observers see objects in the periphery of the visual field.

Methods (across studies)

Test Conditions

- Target was usually high-contrast white disk or light displayed against a darker background
- Diameter of test target ranged from ~1 min-7 deg

- Luminance of test target typically ranged between 3-30 cd/m²
- For Fig. 2, all stimuli presented along vertical and horizontal axes

Experimental Procedure

- Various methods used
- Independent variables: position of target in visual field, target size
- Dependent variable: detectability of target

- Observer's task: report presence of target
- Number of observers varied across studies

Experimental Results

- The visual field for each eye alone extends ~60 deg above and below the center of the visual field, slightly over 100 deg to the outside, and ~60 deg to the inside (where it is limited by the nose) (Fig. 1).
- The visual field for both eyes together extends ~60 deg top and bottom and ~ 100 deg to the sides. (Fig. 1)
- The size of the visual field decreases as the size of the target used to measure the field decreases (Fig. 2).

- The curves in Fig. 2 are ellipses fit to measurements taken on the horizontal and vertical axes only. The curves probably overestimate slightly the size of the visual field in the lower left quadrant, where the field is limited by the nose (Fig. 1).

Variability

The standard deviation between individuals in visual field size is ~8 deg. The standard deviation for a given individual is ~3 deg.

Constraints

- The size of the visual field varies with the size, luminance, contrast, and exposure duration of the target as well as the method of measurement.

- The size of the visual field is influenced by the age, health, fatigue, gender, and experience of the observer (CRef. 1.236).
- Visual fields for colored targets are different from those for achromatic targets (CRef. 1.237).

Key References

*1. Borish, I. M. (1970). *Clinical refraction* (3rd ed.). Chicago: Professional Press.

2. Burg, A. (1968). Lateral visual field as related to age and sex. *Journal of Applied Psychology*, 52, 10-15.

3. Farrell, R. J., & Booth J. M. (1984). *Design handbook for imagery interpretation equipment*. Seattle, WA: Boeing Aerospace Co.

*4. Harrington, D. O. (1964). *The visual fields*. St. Louis: Mosby.

5. Schlichting, C. L., & Rodriguez, R. (1983). *The stability of visual field measures with repeated testing* (NSMRL-1008). Groton, CT: Naval Submarine Medical Research Laboratory. (DTIC No. ADA132704)

Cross References

1.236 The lateral achromatic visual field: age and sex differences;

1.237 Normal visual fields for color

1.236 The Lateral Achromatic Visual Field: Age and Sex Differences

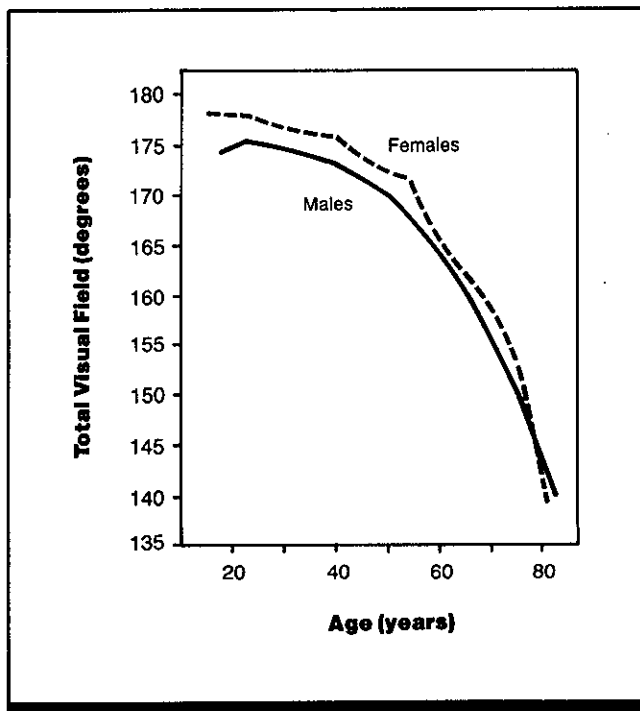

Figure 1. Total lateral visual field by age and sex. Values are means averaged across left and right eyes. (From Ref. 1)

Key Terms

Field of view; perimetry; peripheral vision; visual field

General Description

The size of the lateral **achromatic** visual field (i.e., the maximum field of view from left to right in one eye) progressively declines with age for adults over 30-35. Females have slightly larger lateral visual fields than do males.

Applications

Progressive diminution of visual field in persons over age 35 may decrease performance in tasks such as air-to-air target acquisition, target tracking, and driving.

Methods

Test Conditions

- 4-mm white targets subtending 46 min arc of visual angle located at 5-deg intervals around a black mat screening perimeter arc with 30 cm radius; each target presented by depressing spring-loaded plunger in back of arc and was removed from view as soon as

- plunger was released; arc illuminated by 50-W, 120-V incandescent bulb in otherwise light-free room
- Target 69 cm from center of light source; illuminance of 21.5 lux (2 fc) measured perpendicular to subject-to-target line of sight
- Sequential monocular viewing with each eye; head stabilized in chin rest; fixation on 4-mm target at

center of arc; limits of lateral nasal and temporal fields established by recording position of most peripheral target perceived

Experimental Procedure

- Modified method of limits
- Independent variables: age, gender
- Dependent variables: angular

distance from straight ahead of most peripheral target perceived in left and right visual fields

- Observer's task: indicate whether each target presented could be seen
- ~17,300 observers, who were California drivers; 62.8% male, 37.2% female; ages 16-92; corrected static acuity of 20/13-20/200

Experimental Results

- The lateral achromatic (monocular) visual field is maximal from age 16 (youngest age tested) to ~35 for both sexes, then decreases progressively with advancing age.
- Except for the relatively small age group of >80 yrs, females have slightly larger visual fields on average than do males.
- The greatest difference between males and females is in the nasal visual field (from center of visual field to the nose for each eye).

Constraints

- Accuracy of scores is limited by the 5-deg spacing of targets in test device.
- Target illumination was lower than commonly used in perimetric studies of this type. Older observers may have

- The nasal visual field increases up to age 30-40, then decreases, while the temporal field (from center of field toward the outside) is maximal or almost maximal at first age tested.

Variability

Average standard error was 6.5%. In general, standard deviation is higher for males and subjects over age 60 yrs.

Key References

*1. Burg, A. (1968). Lateral visual field as related to age and sex. *Journal of Applied Psychology, 52*, 10-15.

been slightly penalized, since sensitivity to light diminishes with increasing age.

- The size of the visual field varies with target characteristics, such as size, color, contrast, and luminance, as well as with the method of measurement (CRefs. 1.235, 1.237).

Cross References

1.235 The normal achromatic visual field;

1.237 Normal visual fields for color

1.237 Normal Visual Fields for Color

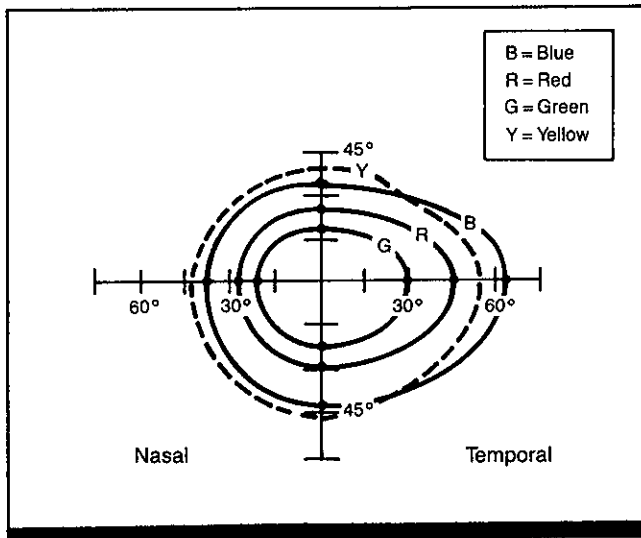

Figure 1. Normal visual fields for color (monocular). (Fields are shown for the right eye; fields for the left eye would be mirror images of those for the right eye.) Curves are averages across several studies. (Based on data in Refs. 1, 2)

Key Terms

Field of view; perimetry; peripheral vision; visual field

General Description

Normal **monocular** visual fields for different colors are somewhat irregularly shaped ellipses of different sizes. The blue and yellow fields are larger than the red and green fields. Chromatic visual fields do not have definite borders, but drop off gradually and very irregularly over a range of 15-30 deg of visual angle.

Applications

Displays and environments in which observers must see colored targets in the periphery of the visual field.

Methods (across studies)

Test Conditions

- Circular stimuli typically ranging in diameter from 0.1-1 deg
- Target luminance ranging from 1-30 cd/m²

Experimental Procedure

- Variety of methods used
- Independent variables: color and position of the target
- Dependent variable: perceptibility of the target

- Observer's task: either to report the presence of a known color or to identify the color of an unknown target
- Number of observers across several studies ranged from 4 to 17,479

Experimental Results

- Visual fields differ slightly for blue, red, green, and yellow targets (Fig. 1).
- Blue and yellow fields are larger than the field for red, which is larger than the field for green.

Variability

Individual differences in chromatic visual fields range from ~3 deg for green to ~30 deg for red and yellow. The standard deviation of the mean threshold for a given individual is ~4 deg.

Constraints

- The sizes of the chromatic visual fields vary with the physical characteristics of the test target, such as size, exposure duration, and luminance (it is particularly difficult to properly equate the luminance of different colors at different retinal locations).
- The sizes of the chromatic visual fields are influenced by

the method of measurement; e. g., measured fields are smaller when the observer must identify the color of the target than when the observer must simply detect the target.

- Physiological and psychological characteristics of the observer (such as age, gender, and the criteria used by the observer in judging whether a color has been seen) affect the sizes of the chromatic visual fields.

Key References

- *1. Arakawa, Y. (1953). Quantitative measurements of visual fields for colors. *American Journal of Ophthalmology*, 36, 1594-1601.
- *2. Borish, T. M. (1970). *Clinical refraction* (3rd ed.). Chicago: Professional Press.
- 3. Connors, M. M., & Kelsey, P. A. (1961). Shape of the red and green color zone gradients. *Journal of the Optical Society of America*, 51, 874-877.
- *4. Farrell, R. J., & Booth, J. M. (1984). *Design handbook for imagery interpretation equipment*. Seattle, WA: Boeing Aerospace Co.
- *5. Harrington, D. O. (1964). *The visual fields*. St. Louis: Mosby.
- 6. Kelsey, P. A., & Schwartz, I. (1959). Nature of the limit of the color zone in perimetry. *Journal of the Optical Society of America*, 49, 764-769.

Cross References

- 1.235 The normal achromatic visual field;
- 1.236 The lateral achromatic visual field: age and sex difference

1.238 Visual Field Coordinate Systems

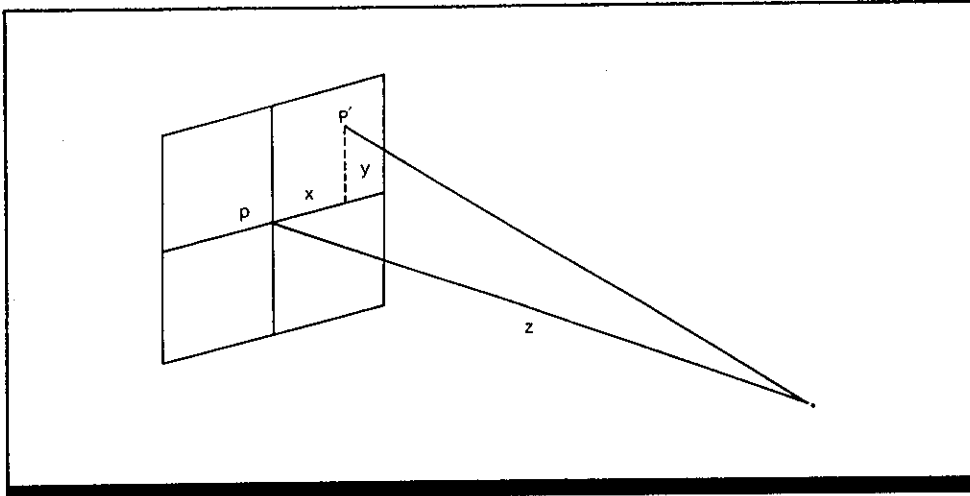

Figure 1. Three-dimensional rectangular coordinate system used to identify the position of target P' in the visual field. The origin is the entrance pupil of the eye; point P at coordinates $(0, 0, z)$ is the fixation point, joined to the center of the entrance pupil by the primary line of sight. The x and y values characterize the horizontal and vertical displacement of the target from the fixation point. (From Ref. 1)

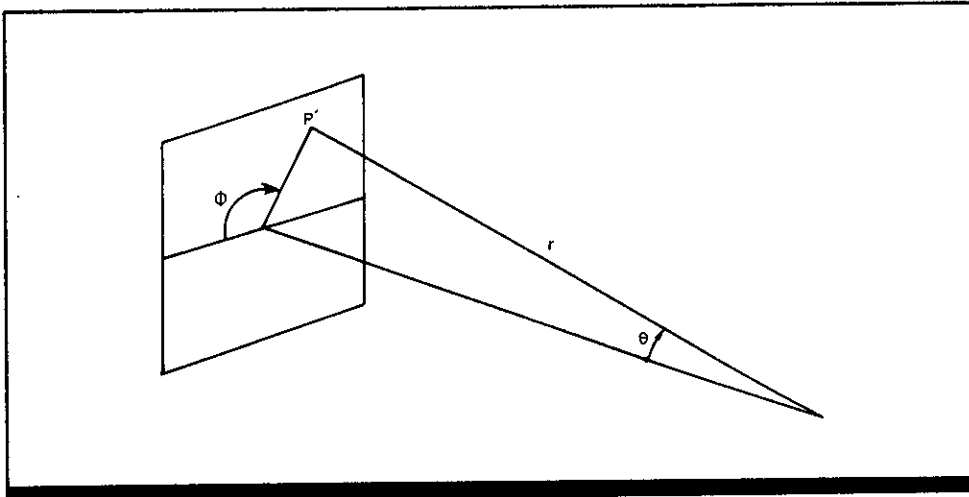

Figure 2. Polar system of coordinates used to specify the location of a target, P' , in the visual field with respect to the center of the entrance pupil and the primary line of sight. Any plane containing the primary line of sight is called a meridian. Point P' lies in a meridian making an angle ϕ with the horizontal. The angle θ is the angle of eccentricity, defined as the angle between the primary line of sight and the visual target with respect to the eye's entrance pupil. The radius vector is r . (From Ref. 1)

Key Terms

Optical reference system; polar coordinate system; rectangular coordinate system

General Description

When an observer looks at a point target, a constant and repeatable relationship is established between the eye and the target image on the retina. Two methods for specifying this relationship are the rectangular coordinate system and the polar coordinate system. In the three-dimensional, rectangular coordinate system (Fig. 1), the line from the point of fixation to the entrance pupil of the eye (the origin) is the z-axis, the primary line of sight; the x- and y-axes describe, respectively, the horizontal and vertical displacement of the target, P' , from the primary line of sight. The fixation point has coordinates $(0, 0, z)$.

The polar coordinate system (depicted in Fig. 2) is preferred to the rectangular system because it is more compatible with the anatomy of the eye. When rectangular coordinates are translated to polar coordinates, the z-axis becomes the radius vector r , and the second coordinate is the angle ϕ , the deviation of the target from the eye's horizontal meridian plane. Following the convention of

ophthalmic optics, looking toward the eye, the value of ϕ is 0 deg at the right of the eye, 90 deg above the eye, 180 deg at the left, and 270 deg below the eye. The third coordinate, θ , describes the angle of eccentricity between the primary line of sight and the line connecting the locus of the target (e.g., P') to the center of the entrance pupil. The relationship among ϕ , θ , and r and the rectangular coordinates appear in Eqs. 1-3:

$$\theta = \tan^{-1} (y/z) \quad (1)$$

$$\phi = \tan^{-1} \left[\frac{(x^2 + y^2)^{0.5}}{z} \right] \quad (2)$$

$$r = (x^2 + y^2 + z^2)^{0.5} \quad (3)$$

In addition to these geometrical coordinate systems describing target-eye relationships, there are also coordinate systems that describe eye movements (CRef. 1.903).

Key References

*1. Westheimer, G. (1986). The eye as an optical instrument. In K. R. Boff, L. Kaufman, & J. P. Thomas (Eds.), *Handbook of per-*

ception and human performance: Vol. 1. Sensory processes and perception. New York: Wiley.

Cross References

- 1.201 Anatomy of the human eye;
- 1.203 The eye as an optical instrument;
- 1.903 Coordinate systems for describing eye movements

1.239 Visual Effects of Empty-Field (Ganzfeld) Viewing

Key Terms

Depth perception; empty field myopia; Ganzfeld; visual illusions

General Description

A Ganzfeld (empty field) is a spatially extended, structureless visual field of homogeneous texture and uniform illumination. In the laboratory, a Ganzfeld can be produced in several ways, but a simple means of inducing the experience is to place one-half of a ping-pong ball over each eye, blocking out images of objects but not light. An experience similar to such an empty field can occur in real environments during high-altitude flight (Ref. 2) and in thick fog or heavy snow (Ref. 3).

Observers placed in a Ganzfeld or Ganzfeld-like situation often experience major disorganizations of visual functioning (Ref. 1).

1. Depth perception is seriously distorted. Many observers report that the Ganzfeld experience is like being in a fog that begins within a foot of the face and extends indefinitely. The "fogginess" is reduced when the otherwise uniform visual space has a detectable microstructure and is under bright illumination. The apparent distance of an object placed in an otherwise empty field depends somewhat on

brightness level and degree of homogeneity of the visual space, but there are large individual differences in apparent distance under such conditions.

2. The refractive state of the eye becomes unstable, fluctuating in an uncontrolled manner; on average, there is a tendency toward **nearsightedness**.

3. Visual search performance may be seriously impaired in a Ganzfeld-like situation, apparently because observers have difficulty determining their direction of gaze. One study (Ref. 1) reported that observers took up to 20 sec to find a target in an otherwise homogeneous field.

4. A temporary cessation of vision known as "blankout" may occur. During "blankout" periods, observers are unable to recognize simple forms such as circles and squares and their **electroencephalograms** show increases in **alpha wave** activity, as though their eyes were closed.

5. Extended viewing of a Ganzfeld with chromatic illumination tends to result in a loss of color perception, with the Ganzfeld becoming desaturated or colorless.

Applications

Individuals who may encounter Ganzfeld-like situations (e.g., pilots of high-flying aircraft, divers, people in arctic regions) should be taught about the characteristic disorient-

ing effects of Ganzfeld stimulation. The experience will be less terrifying if it can be labeled, and it can be counteracted by introducing structure into the visual field (e.g., by putting one's hand in the field of view).

Constraints

- Effects of the Ganzfeld in the laboratory can be disrupted by introducing structure into the visual field.
- Little is known about how well laboratory-produced Ganzfelds (in which the observer can walk away from the field) simulate all the effects of naturally occurring Ganzfelds (in which the observer is in the field).

Key References

1. Avant, L. L. (1965). Vision in the Ganzfeld. *Psychological Bulletin*, 64, 246-258.

2. Whiteside, T. C. D. (1957). *The problems in flight at high altitude*. London: Pergamon Press.

3. Wyszecki, G. (1956). Theoretical investigation of colored lenses for snow goggles. *Journal of the Optical Society of America*, 46, 1071-1074.

Notes

✓

✓

✓

✓

1.240 Visual Angle and Retinal Size

Key Terms

Retinal image; retinal size; visual angle; visual image

General Description

The measurements used to describe the size of objects in the environment do not apply to the projection of those objects onto the surface of the **retina**. For this reason, in visual studies, visual extent is conventionally designated in terms of angular units or visual angle. The use of visual angle is advantageous because visual angles bear a constant relationship to retinal distances in a given eye, and they are highly comparable from one eye to the next. The parameters involved in the calculation of visual angle are depicted in Fig. 1.

The distance S is the physical size of the object, expressed in units generally used to describe length (e.g., meters or centimeters). The distance D is the distance of the target object from the **nodal point** of the eye. Visual angle is used to express projected sizes of objects in the environment. The visual angle, α , of the object can be found by:

$$\alpha_{\text{deg}} = \arctan (S/D),$$

where α is expressed in degrees. This is pure visual subtense of the projection of the object onto the retinal surface. For small angles, a simpler version of the formula can be used, with α expressed in radians ($\alpha_{\text{rad}} = \alpha_{\text{deg}}/57.3$):

$$\alpha_{\text{rad}} = S/D.$$

The simplified formula does introduce some error into the calculation of visual angle. At 10 deg, the visual angle will be overestimated by 1%; at 17 deg, the overestimation will be 3%.

The distance D , as defined above, should be used for greatest precision. The distance n is the distance from the corneal surface to the nodal point of the eye, and, in most eyes, is 7 mm. Therefore, it is always possible to add this distance to the corneal surface-to-target object distance to obtain an approximation of D that will serve for most observers. However, for most practical purposes, where D is many times larger than 7 mm, it suffices to take D as the distance between the target object and the surface of the cornea.

Visual angle is also used to express distances along the retinal surface. For example, for targets presented in the periphery of the visual field, the distance of the target from the point of fixation may be expressed as a visual angle. Thus, an object might be reported as appearing 5 deg left of central fixation, meaning that, with the observer's gaze directly ahead, the stimulus was presented 5 deg into the observer's

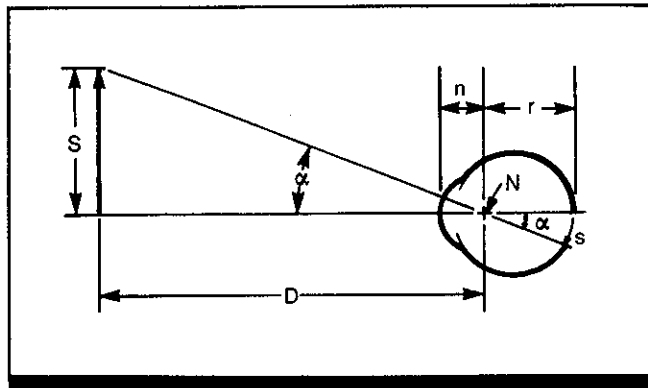

Figure 1. Parameters involved in the calculation of visual angle. S = target size; D = distance of target from nodal point of eye; N = nodal point; n = distance of nodal point from corneal surface (7 mm in most eyes); r = distance of nodal point from retinal surface (17 mm in most eyes); s = retinal extent in length units; and α = visual angle.

peripheral visual field. Calculation of this visual angle is identical to that for object size, except that the distance S is now the distance in the environment of the target object from a central fixation point; this distance is expressed in conventional units of length. The use of visual angle to express retinal distance can also be applied to the description of ocular structures, since they clearly have extent on the retinal surface. For example, the diameter of the fovea (central portion of the retina where acuity is greatest) may be expressed as 30 min arc.

It is possible to express retinal extent in terms of conventional length units when it is convenient or necessary to do so. When the eye is focused at infinity, its focal length is ~ 17 mm, while for focus on very close objects it can be as short as 14 mm. The distance r is the distance from the nodal point of the eye to the retinal surface, and, in most eyes, is thus ~ 17 mm (Ref. 2) for distant objects. The distance s is the size of the retinal projection in millimeters. Thus,

$$\tan \alpha = s/17.$$

But for small angles,

$$\tan \alpha = S/D,$$

and therefore $S = 17S/D$.

Table 1 shows the visual angles associated with some typical objects and ocular structures.

Applications

Laboratory testing situations and design options in which it is necessary to standardize retinal size of displays or display elements from observer to observer.

Constraints

• Visual angle computations should always be accompanied by information regarding the absolute size of the target and the point of reference from which the distance D is measured (e.g., nodal point, corneal surface). This will make it possible to recalculate visual angle for other experimental or operational settings.

• If, for any reason, the equations in the General Description would not apply to the experimental conditions under study, the conditions should be changed so as to make the equations applicable (Ref. 1).

Key References

*1. Graham, C. H. (1965). Visual space perception. In C. H. Graham (Ed.), *Vision and visual perception* (pp. 504-547). New York: Wiley.

2. Haber, R. N., & Hershenson, M. (1973). *The psychology of visual perception*. New York: Holt, Rinehart, and Winston.

3. Westheimer, G. (1986). The eye as an optical instrument. In K. R. Boff, L. Kaufman, & J. P. Thomas (Eds.), *Handbook of perception and performance: Vol. 1. Sensory processes and perception*. New York: Wiley.

Cross References

1.201 Anatomy of the human eye

Table 1. Visual angle associated with some typical objects and ocular structures. (From Ref. 3)

Object	Visual Angle
Alphanumeric character on CRT screen at 20 in	17 minutes of arc
Diameter of moon	36 min arc
2-inch diameter circle at 20 in	5.7 degrees
Diameter of fovea	30 min arc
Diameter of foveal retinal receptor	0.5 min arc
Position of inner edge of blind spot	12 deg from fovea
Size of blind spot	7.5 deg (vertical) 5 deg (horizontal)

Notes



Section 1.3 Sensitivity to Light

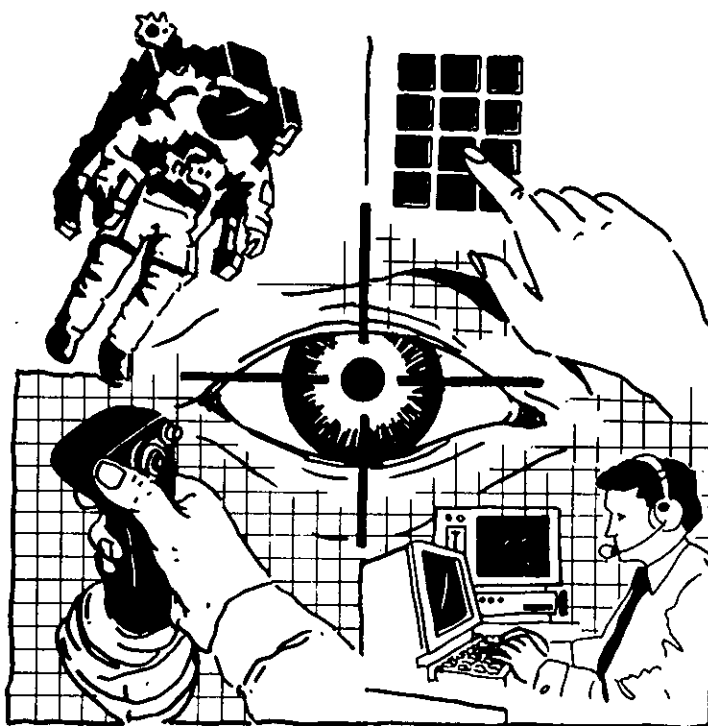

1.301 Scotopic and Photopic (Rod and Cone) Vision

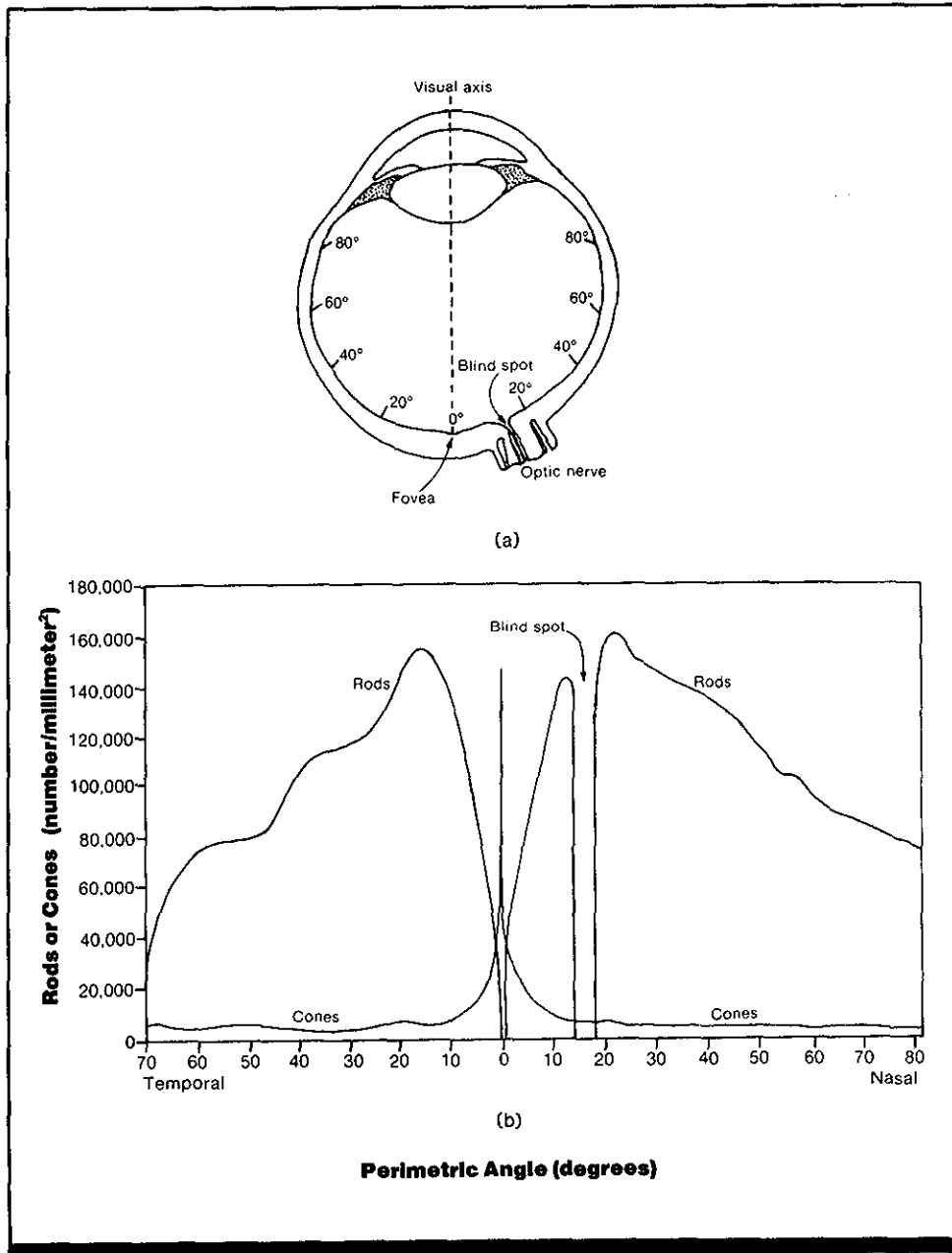

Figure 1. (a) Top view of the left eye. (b) Corresponding densities of rods and cones across the retina. (Ref. 1)

Key Terms

Color appearance; cones; foveal vision; peripheral vision; photopic vision; retina; rods; scotopic vision

General Description

The human retina contains two kinds of photoreceptors (light-sensitive cells)—rods and cones—which differ in their functions and distribution. Cones provide acute vision at daytime (photopic) levels of illumination. Rod vision provides high light sensitivity which makes it possible to see under low (scotopic) illumination levels. Table 1 summarizes the properties of photopic and scotopic vision.

The distributions of rods and cones are not uniform. Cone density is greatest at the fovea and falls sharply to a minimum by ~10 deg from the eye fixation point. Beyond 10 deg, the retina contains a thin, uniform distribution of cones. Rods are not present in the fovea. They are most dense in the near periphery out to ~18 deg. While they decline in number further into the periphery, they are still far denser than cones and dominate vision in the peripheral visual field. The blind spot, the region of the retina where the optic nerve leaves the eye, contains no photoreceptors.

Constraints

- Ability to discriminate detail (visual acuity) is greatest when targets are presented to the fovea.
- Relative sensitivity of the eye to dim light is highest in areas of greatest rod density (Fig. 2). Thus, a dim target may be more likely to be detected if one looks a little to the side of the object rather than directly at it.
- Color vision is dependent upon cones; under scotopic (low) illumination, the visual field appears colorless, although objects may appear to differ in brightness.
- The rods and cones have different spectral sensitivity. Thus, when illumination shifts from scotopic to photopic levels, the wavelength providing the maximum apparent brightness (i.e., wavelength to which the eye is most sensitive) shifts from 505 to 555 nm (the Purkinje shift). The relative brightness of objects of different colors therefore depends at least partly upon the level of ambient illumination (CRefs. 1.303, 1.304).
- The highest detectable rate of flicker is greater for photopic (cone) vision than for scotopic (rod) vision.

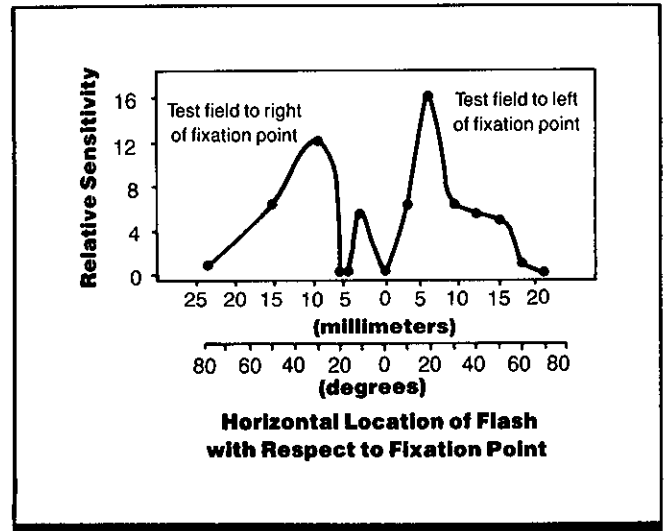

Figure 2. Relative sensitivity of the right eye to dim light as a function of the angular position of the test light with respect to the fixation point. Sensitivity to a dim (but not to a bright) test light closely follows the density of the rods. (cf. Fig. 1b) (Ref. 1)

Key References

*1. Cornsweet, T. N. (1970). *Visual perception*. New York: Academic Press.
 2. Graham, C. H. (1965). *Vision and visual perception*. New York: Wiley.

3. Hood, D. C., & Finkelstein, M. A. (1986). Sensitivity to light. In K. R. Boff, L. Kaufman, & J. P. Thomas (Eds.), *Handbook of perception and human performance: Vol. 1, Sensory processes and perception*. New York: Wiley.

4. Kling, J. W., & Riggs, L. A. (Eds.) (1972). *Woodworth & Schlosberg's experimental psychology* (3rd ed.). New York: Holt, Rinehart & Winston.

Cross References

1.303 Equal-brightness and equal-lightness contours for targets of different colors (spectral content);

1.304 equal-brightness contours for lights of different colors (wavelength) at different levels of adapting luminance;

Handbook of perception and human performance, Ch. 5, Sect. 1.3.2

Table 1. Photopic and scotopic vision of the human eye. (From Ref. 4)

	Photopic	Scotopic
Receptor	Cones (~7 million)	Rods (~120 million)
Retinal location	Concentrated at center, fewer in periphery	General in periphery, none in fovea
Neural processing	Discriminative	Summative
Peak wavelength	555 nm	505 nm
Luminance level	Daylight [1 - 10 ⁷ mL (0.314 - 3.14×10 ⁶ cd/m ²)]	Night [10 ⁻⁶ - 1 mL (3.14×10 ⁻⁷ - 0.314 cd/m ²)]
Color vision	Normally trichromatic	Achromatic
Dark adaptation	Rapid (~7 min)	Slow (~40 min)
Spatial resolution	High acuity	Low acuity
Temporal resolution	Fast reacting	Slower reacting

1.302 Spectral Sensitivity

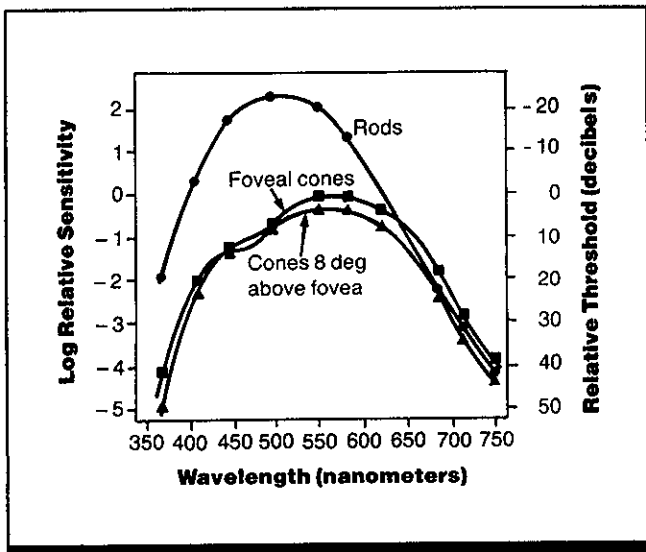

Figure 1. Photopic (cone) and scotopic (rod) spectral sensitivity curves. (From Ref. 2)

Key Terms

Cones; duplicity model; luminous efficiency; photopic vision; rods; scotopic vision; spectral sensitivity; wavelength

General Description

The detectability of light varies with wavelength. Spectral sensitivity functions (Fig. 1) specify the relative spectral sensitivity of the visual system under **scotopic** (nighttime) and **photopic** (daytime) conditions. The scotopic function is assumed to show the spectral sensitivity of the **rod** system; the photopic function, sensitivity of the **cone** system. These two theoretical curves have been adopted by the CIE (Commission Internationale de l'Éclairage) and represent relative spectral sensitivity of the dark-adapted eye and light-adapted eye, respectively.

The duplicity model of vision predicts changes in overall spectral sensitivity with changes in conditions of stimulation (such as adapting intensity or retinal position of the target) on the basis of the different characteristics of the rods and cones (CRef. 1.301). The model assumes that the relative spectral sensitivities of the rod and cone systems are constant and that the sensitivity of one system is unaffected by stimulation of the other, i.e., the systems are independent. Detection at any wavelength is served by the more sensitive system, and overall spectral sensitivity approximates the envelope of the rod and cone curves. Figure 2 shows the predicted effect of changes in conditions that progressively favor the cone system. Figure 2a shows a situation (such as the dark-adapted peripheral retina) where the rod system is more sensitive than the cone system at every wavelength and alone determines detection. In the intermediate situation portrayed in Fig. 2b (produced, e.g., by increasing target size to include the fovea), the rods are more sensitive at

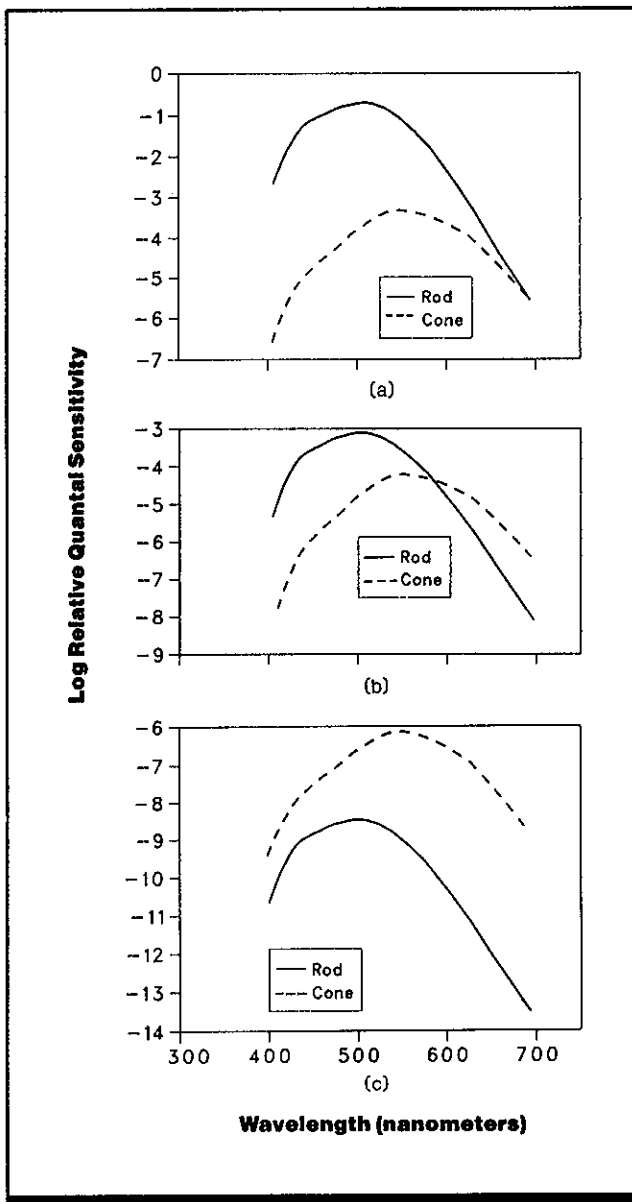

Figure 2. Illustration of the duplicity model of detection. Panels a-c show the effect of changes in conditions that progressively favor the cone system (e.g., increasing adapting illumination). For light of a given wavelength, detection is mediated by the system that is more sensitive to that wavelength under the viewing conditions pertaining. (From Handbook of perception and human performance)

wavelengths below 590 nm and mediate detection in this spectral region, while the cones are more sensitive at wavelengths above 590 nm. Finally, Fig. 2c shows a case favoring cone vision, such as would be produced by adding an adapting background. Here, the sensitivity of the cones is greater at all wavelengths and the cone system alone determines detection.

Applications

Predicting the effects of a wide range of test and adapting conditions, and accounting for shifts in apparent relative brightness of targets of differing wavelengths with changes in ambient illumination (the Purkinje shift).

Empirical Validation

The model has been validated under a wide range of test and adapting conditions and for several different measures of sensitivity.

Constraints

- The duplicity model breaks down at high adapting intensities.
- When spectral sensitivity is measured in the laboratory, the size, duration, and retinal location of the target are usually held constant, and the target is presented at a time known to the observer. Such conditions are seldom found in real-world environments.

- There are individual differences in spectral sensitivity; some such differences are due to differences in pigment density in the macula and primarily affect sensitivity to short-wave light. Color-blind or color-deficient observers show the most extreme departures from the norm.
-

Key References

*1. Hood, D., & Finkelstein, M. (1986). Sensitivity to light. In K. R. Boff, L. Kaufman, & J. P. Thomas (Eds.), *Handbook of perception and human performance: Vol. I. Sensory processes and perception*. New York: Wiley.

2. Judd, D. B. (1951). Basic correlates of the visual stimulus. In S. S. Stevens (Ed.), *Handbook of experimental psychology*. New York: Wiley.

3. Riggs, L. A. (1965). Light as a stimulus for vision. In C. H. Graham (Ed.), *Vision and visual perception*. New York: Wiley.

Cross References

I.301 Scotopic and photopic (rod and cone) vision

1.303 Equal-Brightness and Equal-Lightness Contours for Targets of Different Colors (Spectral Content)

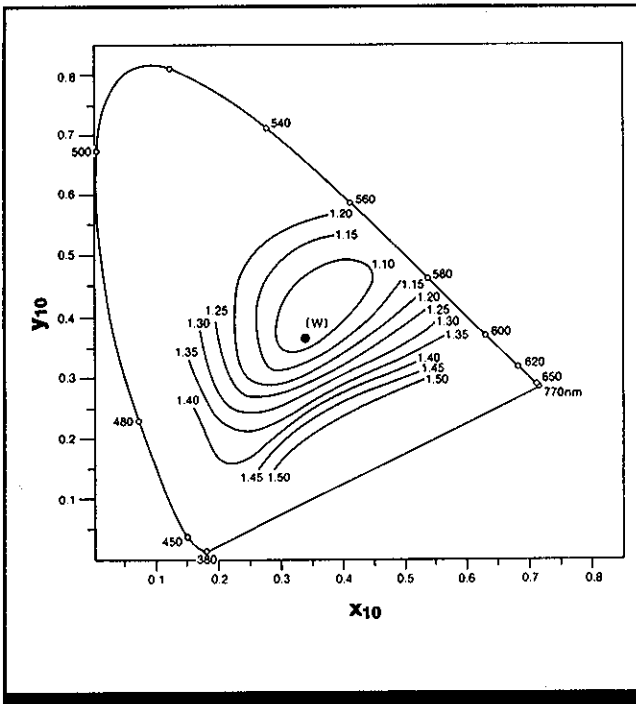

Figure 1. Typical contours of approximately constant brightness (plotted on CIE 1964 $[x_{10}, y_{10}]$ diagram), when colored luminous areas of various chromaticity coordinates and constant 20 cd/m^2 luminance are matched with a white area (W) of variable luminance (Study 1). Numbers refer to the multiplying factor needed for the white area luminance if it is to match in brightness the colored luminous areas whose coordinates fall on that contour. (From Ref. 8)

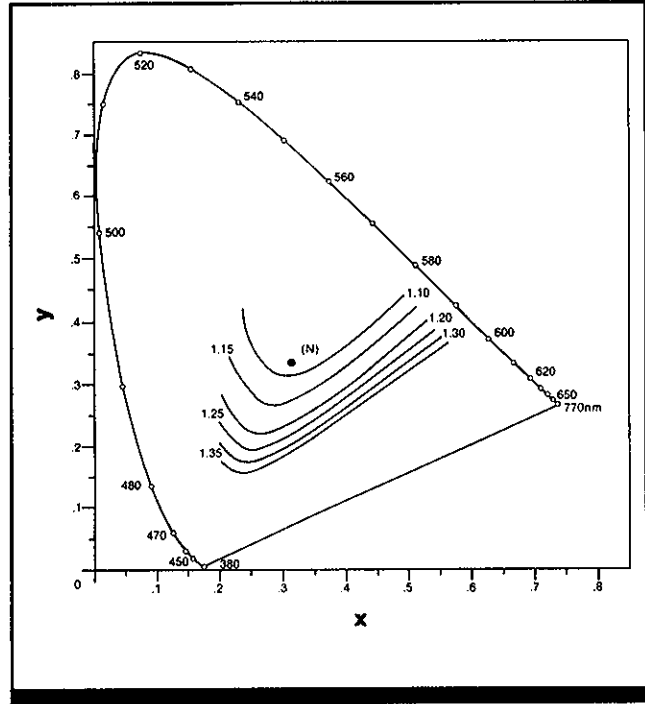

Figure 2. Typical contours of approximately constant lightness (plotted on CIE 1931 $[x, y]$ diagram), when colored ceramic tiles of various chromaticity coordinates and about 30% reflectance are matched with similar gray tiles perceived to have the same level of lightness (Study 2). The luminous reflectance value of an achromatic area (N), when multiplied by the number shown next to a contour, should approximately match in lightness a colored area whose coordinates fall on the contour. (From Ref. 7)

Key Terms

Brightness; chromaticity; color appearance; heterochromatic brightness matching; heterochromatic lightness matching; lightness

General Description

A colored (chromatic) area generally will appear *brighter* or *lighter* than a white or gray (achromatic) area that is otherwise similar. The farther the chromaticity coordinates (CRef. 1.722) of the chromatic test area are from those of the achromatic referent, the greater the test area's relative brightness or lightness (CRef. 1.706).

This relationship can be expressed as a ratio, B/L , where B is the measured or calculated luminance of the achromatic reference area and L is the luminance of the colored test area, when they appear equally bright (i.e., equally intense or emitting the same amount of light) or equally light (i.e., equally dark or light on a scale from black to white). In general, $B/L > 1$, that is, the white area must have higher luminance to match the brightness of the colored area. These ratios are obtained using a process called *heterochromatic brightness matching*, in which two lights of different

wavelength distributions are compared, and one is adjusted in brightness until they appear equal.

Empirically determined values of B/L can be plotted as contours (curved lines of constant value) on a CIE (x, y) chromaticity diagram (CRef. 1.722). Different conditions of viewing and measurement yield somewhat different results, so various studies usually cannot be compared quantitatively. Two typical examples are shown here.

Figure 1 provides B/L constant *brightness* contours for chromatic test areas with constant 20 cd/m^2 luminance that subtend 10 deg arc at the eye, compared with variable luminance white areas of the same size, both against a white background. The white area, of chromaticity value W, when compared with a blue stimulus in the 480 nm range [$x = 0.15, y = 0.2$ on the CIE 1964 (x_{10}, y_{10}) diagram], must have luminance 1.4 times that of the blue area to appear equally bright. Similarly, for equal brightness the white area

must have luminance 1.2 times that of a yellow area (approximately 580 nm; $x = 0.5$, $y = 0.42$).

Figure 2 illustrates B/L constant *lightness* contours for small colored ceramic tiles. These were compared in daylight with similar gray tiles of known luminous reflectance, varying in ten equal steps of middle gray shades at chroma-

ticity coordinates N . Values are plotted on the CIE 1931 (x, y) chromaticity diagram. To appear equally light, the achromatic test sample must have higher luminous reflectance than a blue sample (1.35 times) or a yellow one (1.1 times), under these particular test conditions.

Applications

Development of **luminous efficiency functions** for general use in the photometry of colored lights and luminous areas; selection and specification of chromaticity coordinates for colored areas or lights when constant lightness or brightness is important, such as in navigation signals and in multico-

lored display formats for electro-optical and other luminous displays; selecting or specifying paint and other surface treatment colors when the appearance of homogeneous lightness and brightness is important, as in art galleries and photographic studios.

Methods

Test Conditions

Study 1 (Ref. 6)

- Binocular viewing of bipartite test and reference field; observer encouraged not to fixate on target
- Adjacent test light and reference light each 10 deg arc of visual angle, viewed against a white 40 deg arc background
- Luminous test areas of 95 hues, with constant 20 cd/m² luminance
- White referent luminous area ($x_{10} = 0.34$, $y_{10} = 0.36$) with luminance adjustable by observer

Study 2 (Ref. 7)

- Test areas consisting of 43 colored hexagonal ceramic tiles, 5 cm inside diameter (about 10 deg arc of visual angle), approximately 30% luminous reflectance
- Lightness referent consisting of 10 gray tiles ($x = 0.32$, $y = 0.32$) with **Munsell values** of 5.6 to 7.4 in steps of 0.2, otherwise identical to the test tiles
- Viewing angle between 20 and 45 deg from vertical; daylight illumination (natural or artificial)

Experimental Procedure

Study 1

- Method of adjustment
- Independent variable: chromaticity coordinates of colored test lights
- Dependent variable: luminance of referent white light when brightness matches test light brightness
- Observer's task: adjust luminance of white referent light until its brightness matches colored test light brightness
- 20 observers with normal color vision

Study 2

- Method of direct matching
- Independent variable: chromaticity coordinates of colored tiles
- Dependent variable: Munsell value of gray referent tile when lightness matches test tile lightness
- Observer's task: compare test tile lightness with lightness of 10 gray referent tiles and select the closest lightness match; selection of a lightness value between two gray tile Munsell values allowed
- 76 observers with normal color vision

Constraints

- Standard heterochromatic brightness or lightness scales do not exist at this time; typical constant brightness or lightness contours are obtained by smoothing discrete data points; they are approximate in nature and will only poorly predict the judgments of a particular individual.
- Brightness and lightness judgments are influenced by many factors, including individual observer differences; instructions given to the observers; the comparison technique used (adjustment or direct matching); the overall range of luminance or illuminance levels; whether the test areas are self-luminous (lights) or are illuminated surfaces; the size of test and comparison fields, distance between them, and presence or absence of a separating border; the lightness and color of the surround; and **foveal** versus **peripheral** fixation (CRef. 1.707).

- Variability of lightness judgments is greater for heterochromatic than for homochromatic matching, and is strongly influenced by test area chromaticity coordinates; variability increases sharply at short wavelengths (blue-violet), where the eye is relatively insensitive and **chromatic aberration** results in poor visual focus.
- When matched in luminance with an achromatic reference area, a chromatic area of complex **spectral radiant power distribution** may appear to glow (fluoresce) (CRef. 1.711). This is sometimes referred to as the Helmholtz-Kohlrausch effect.
- For some yellow test areas, the ratio B/L is approximately unity, even at maximum saturation; i.e., white and yellow areas with the same luminance may appear equally bright.
- Lightness or brightness values are not additive; i.e., combining two different colored lights of equal brightness does not result in one light with twice the brightness.

Key References

1. Alman, D.H. (1977). Errors of the standard photometric system when measuring the brightness of general illumination of light sources. *Journal of the Illuminating Engineering Society*, 7, 55.
2. Breneman, E. (1958). Dependence of luminance required for constant brightness upon chromaticity and chromatic adaptation. *Journal*

of the Optical Society of America, 48, 228-232.

3. Chapanis, A., & Halsey, R.M. (1955). Luminance of equally bright colors. *Journal of the Optical Society of America*, 45, 1-6.

4. Sanders, C.L., & Wyszecki, G. (1957). Correlate for lightness in terms of CIE-tristimulus values. Part I. *Journal of the Optical Society of America*, 47, 398-404.

5. Sanders, C.L., & Wyszecki, G. (1958). L/Y ratios in terms of CIE-chromaticity coordinates. *Journal of the Optical Society of America*, 48, 389-392.

*6. Sanders, C.L., & Wyszecki, G. (1964). Correlate for brightness in terms of CIE color matching data (Paper P-63.6). In *Proceedings of the 15th session of the Commission Internationale de l'Eclairage*, Vi-

enna, 1963. Paris: CIE Central Bureau.

*7. Wyszecki, G. (1967). Correlate for brightness in terms of CIE chromaticity coordinates and luminous reflectance. *Journal of the Optical Society of America*, 57, 254-257.

*8. Wyszecki, G., & Stiles, W.S. (1982). *Color science* (2nd ed.). New York: Wiley.

Cross References

- 1.304 Equal-brightness contours for lights of different colors (wavelengths) at different levels of adapting luminance;
- 1.701 Targets and procedures used to study color perception;

- 1.706 Descriptive attributes of color appearance;
- 1.707 Factors influencing color appearance;
- 1.709 Hue: effect of luminance level (Bezold-Brücke effect);

- 1.710 Hue and chroma: shifts under daylight and incandescent light;
- 1.711 Fluorescence or color glow;
- 1.712 Brightness constancy;
- 1.720 Brightness scales;

- 1.721 Lightness scales;
 - 1.722 Color specification and the CIE system of colorimetry;
 - 1.723 Color-order systems;
- Handbook of perception and human performance*, Ch. 8, Sect. 2.2

1.304 Equal-Brightness Contours for Lights of Different Colors (Wavelengths) at Different Levels of Adapting Luminance

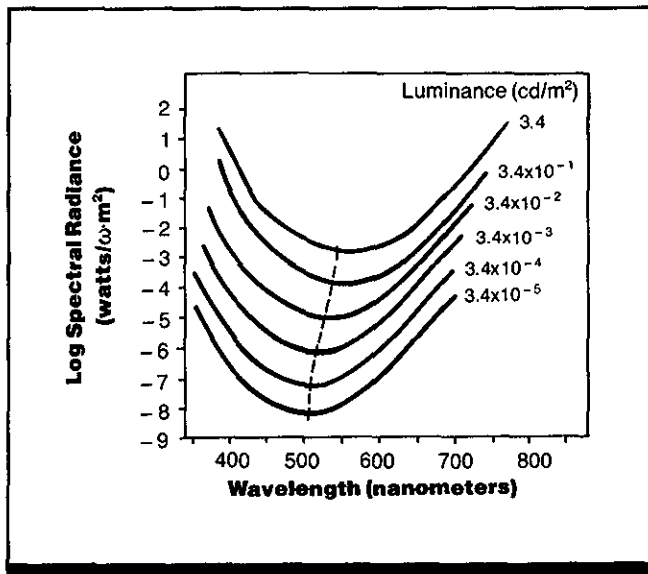

Figure 1. Relative energy level required to produce perceptions of equal brightness for an observer adapted to luminance levels ranging from 3.426 cd/m^2 (1 fL) to $3.426 \times 10^{-5} \text{ cd/m}^2$ (10^{-5} fL). These luminance levels correspond to snow illuminated by starlight (lowest contour), quarter moon, full moon, deep twilight, and twilight with the sun just below the horizon (upper contour). The dashed line indicates the wavelength of greatest sensitivity at each radiance level. (From Ref. 3)

Key Terms

Brightness; luminous efficiency; Purkinje shift; spectral sensitivity

General Description

The brightness of a light depends on both the intensity of the light (e.g., as measured in watts/steradian m^2) and the wavelength of the light. As intensity increases, brightness also increases, although wavelength mediates the effect. That is, with light at **photopic** (daytime) levels (above $\sim 3 \text{ cd/m}^2$) an observer will show maximum sensitivity at about 555 nm; lights at other wavelengths, but with the same energy output, will be perceived as dimmer. These lights will achieve the same brightness as a light of 555 nm only when their radiant output is increased. These values correspond to the values determined for the CIE photopic and scotopic luminous efficiency functions (CRef. 1.110). As the radiance level of the lights decreases to **scotopic** (night time) levels, the wavelength of greatest sensitivity shifts toward shorter wavelengths, so that at

0.0000343 cd/m^2 , the wavelength of maximum brightness is $\sim 500 \text{ nm}$. This shift in the region of greatest sensitivity with illumination level is known as the Purkinje shift.

Figure 1 depicts the regular displacement in sensitivity as a function of wavelength (Ref. 4). The shift in the brightness contours is due to the predominance of photopic (**cone**) activity at high radiance levels, mesopic (mixed **rod** and cone) activity at moderate levels, and scotopic (rod) activity alone at very low levels (CRef. 1.110).

Related to this shift in sensitivity is the fact that color appearance changes with intensity changes (CRefs. 1.709, 1.710). Specifically, as lights at the long wavelength end of the visible spectrum become dimmer, they lose their color before lights in the middle of the spectrum. Numerous factors will affect sensitivity (CRefs. 1.704, 1.705).

Applications

When different visual displays or lights need to be equally bright, the interaction of wavelength and intensity of the light needs to be considered. When responses are dependent on brightness judgments, the same considerations are crucial.

Key References

1. Crawford, B. H. (1949). The scotopic visibility function. *Proceedings of the Physics Society*, 62, 321-334.

2. Gibson, K. S., & Tyndall, E. P. T. (1923). Visibility of radiant energy, *Bulletin Bureau of Standards*, 19, 131.

3. Judd, D. B. (1951). Basic correlates of the visual stimulus. In S. S. Stevens (Ed.), *Handbook of experimental psychology*. New York: Wiley.

4. Weaver, K. S. (1949). A provisional standard observer for low level photometry. *Journal of the Optical Society of America*, 39, 278-291.

Cross References

1.102 Spectral distribution of radiant energy;

1.109 Photometric techniques for measuring spectral sensitivity;

1.110 Luminous efficiency (spectral sensitivity);

1.302 Spectral sensitivity;

1.303 Equal-brightness and equal-lightness contours for targets of different colors (spectral content);

1.704 Chromaticity discrimination;

1.705 Factors affecting color discrimination and color matching;

1.709 Hue: effect of luminance level (Bezold-Brücke effect);

1.710 Hue and chroma: shifts under daylight and incandescent light;

1.720 Brightness scales;

1.721 Lightness scales

1.305 Factors Affecting Sensitivity to Light

Key Terms

Dark adaptation; intensity difference threshold; light adaptation; luminance; retinal location; size; spatial summation; temporal summation; visual field location; visual sensitivity; wavelength

General Description

The ability of the observer to detect a light is influenced by characteristics of the target and the surrounding environment. Sensitivity to light typically is reported as the reciprocal of the detection threshold so that larger numerical values indicate greater sensitivity. The table summarizes the effect of several factors on sensitivity to light.

Factor	Effect on Sensitivity	References
Level of illumination	Sensitivity is greater in low than in high ambient illumination	Ref. 1
Wavelength	Maximum sensitivity at daytime (photopic) illumination levels (cone system) is to targets of ~555 nm wavelength Maximum sensitivity at nighttime (scotopic) illumination levels (rod system) is to wavelengths of ~500 nm	CRefs. 1.302, 1.304
Retinal location	Except for the blind spot, the lowest absolute sensitivity (i.e., sensitivity in the dark) is at the fovea (center of visual field) Sensitivity is greatest ~20 deg from the fovea on the temporal side of the horizontal meridian (nasal visual field)	CRef 1.306
Target size	Up to a critical size, increasing target size lowers the threshold for light (i.e., spatial summation occurs) The critical size is much lower for foveally presented targets (~6 min arc of visual angle) than for peripheral targets (generally ~0.5-1.0 deg); some spatial summation occurs for peripheral targets up to ~2.0 deg in size	CRef. 1.308
Duration of light adaptation (time since onset of adapting field)	Sensitivity is lowest immediately after onset of adapting fields Scotopic (rod) sensitivity increases rapidly within 200 msec; further increases are gradual Photopic (cone) sensitivity increases rapidly during the first several seconds, reaching a maximum after ~3 min; especially at high adaptation levels, sensitivity then drops slightly and finally levels off after ~10 min	CRef. 1.405
Dark adaptation (time in dark or time since decrease in illumination)	Sensitivity of the visual system increases after a decrease in ambient illumination; from several seconds to 30 min or more are required to reach maximum sensitivity, depending on exposure conditions The cone system dark-adapts more quickly than the rod system but the absolute sensitivity of the rod system is greater	CRef. 1.406
Duration of stimulus	Up to ~100 msec, increasing duration lowers the illumination threshold (i.e., temporal summation occurs) for a stimulus of constant size	CRef. 1.512

Constraints

- Interactions may occur among the various factors affecting sensitivity to light. For example, temporal and spatial summation decrease with increases in ambient illumination.

Key References

I. Hood, D., & Finkelstein, M. (1986). Sensitivity to light. In K. R. Boff, L. Kaufman, & J. P. Thomas (Eds.), *Handbook of perception and human performance*: Vol. I. *Sensory processes and perception*. New York: Wiley.

Cross References

1.302 Spectral sensitivity;

1.304 Equal brightness contours for lights of different colors (wavelengths) at different levels of adapting luminance;

1.306 Absolute sensitivity to light: effect of visual field location;

1.308 Spatial summation of light energy;

1.405 Time course of light adaptation;

1.406 Factors affecting dark adaptation;

1.512 Time-intensity trade-offs in detection of brief targets: effect of duration, target intensity, and background luminance

1.306 Absolute Sensitivity to Light: Effect of Visual Field Location

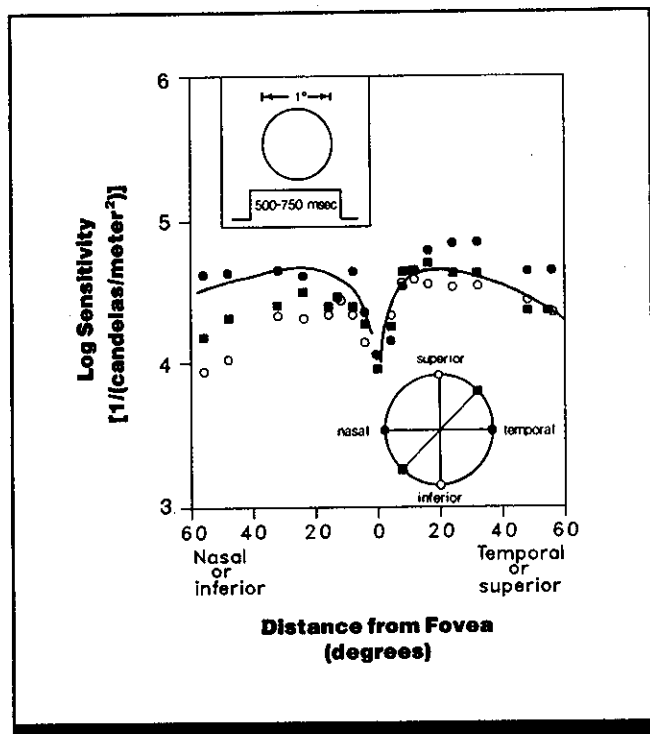

Figure 1. The relation between absolute sensitivity to light ($1/\text{threshold}$) and distance from fovea (eye fixation) along horizontal (filled circles), vertical (open circles), and 45-deg meridia (squares). The solid curve shows the distribution of rods across the retina. (From *Handbook of perception and human performance*, based on data from Ref. 2)

Key Terms

Dark adaptation; retinal location; scotopic vision; visual field location; visual sensitivity

General Description

Absolute sensitivity to light (sensitivity of the **dark-adapted eye**) is maximal when the angular distance of the target from the **fixation point** (or center of the **fovea**) is ~ 20 deg of visual angle. Absolute sensitivity is greatest along the horizontal meridian, particularly in the temporal retina (corresponding to the nasal portion of the visual field)

and is least in the inferior (lower) retina (corresponding to the top of the visual field). The shapes of the functions relating sensitivity to distance from the fovea are similar for horizontal, vertical, and 45-deg meridia (extending from inferior nasal to superior temporal retina) and resemble the distribution of **rods** on the retina.

Methods

Test Conditions

- After 40 min of dark adaptation, observer visually fixated small spot of light or, for foveal measurements, the center of four white lights; 1-deg diameter target was presented at a position $\sim 4, 8, 12, 24, 32, 48,$ or 56 deg from fixation

- at one of eight equally spaced meridians (data presented here only for horizontal, vertical, and 45-deg meridia); target duration 500-750 msec
- Four 2.5-hr test sessions per observer with frequent rest periods
- All observations were monocular and made with natural pupil of right eye

Experimental Procedure

- Method of limits (modified); target intensity increased until observer indicated seeing two successive flashes (defined as threshold)
- Independent variable: retinal location

- Dependent variable: target intensity at threshold, defined as median of five threshold estimates made for each target location; figure plots sensitivity, or $1/\text{threshold}$
- Observer's task: indicate whether target was seen on each trial
- Five threshold estimates per observer at each retinal position
- 8 practiced observers

Experimental Results

- Absolute sensitivity to light is lower (threshold is higher) in the fovea than in any other retinal location tested, except for the **blind spot** (CRef. 1.101).
- Sensitivity increases as distance from fixation increases from 0 deg to 12-22 deg, remains fairly constant until 32 deg, and then begins to fall with additional increases in angular target distance from the fovea (Fig. 1).
- The shapes of the sensitivity functions are similar for horizontal, vertical, and 45-deg meridians; the most extended regions of high sensitivity are seen along the horizontal meridian.
- Sensitivity is greatest ~20 deg from the fovea on the temporal side of the horizontal meridian. Sensitivity is lowest in the extreme lower retina.

- Regardless of the direction of the target from the fovea, a point is reached beyond which the sensitivity decreases with increasing distance from the fovea.
- Sensitivity decreases slightly in the nasal retina at target distances roughly equaling the distance of the blind spot from fixation (~14-18 deg).

Variability

No information on variability was given.

Repeatability/Comparison with Other Studies

The low sensitivity in the inferior retina is consistent with the results of Refs. 3 and 4. Areas of maximal sensitivity correspond to areas of maximal receptor density (Ref. 1).

Constraints

- Many factors (such as wavelength of the target) influence sensitivity to light and should be considered in applying these results under different conditions (CRef. 1.305).

- The data are uncorrected for the decrease in effective pupil size produced by increasingly oblique angles of view. Therefore, sensitivity is somewhat underestimated for larger peripheral angles (CRef. 1.111).

Key References

1. Osterberg, G. (1935). Topography of the layer of rods and cones in the human retina. *Acta Ophthalmologica*, 6 (Suppl), 1-102.

*2. Riopelle, A. J., & Bevan, W., Jr. (1953). The distribution of scotopic sensitivity in human vision. *American Journal of Psychology*, 66, 73-80.

3. Riopelle, A. J., & Hake, H. W. (1951). Area intensity relations in scotopic vision using annular stimuli. *Journal of Experimental Psychology*, 52, 54-58.

4. Stiles, W. S., & Crawford, B. H. (1937). The effect of a glaring light source on extrafoveal vision. *Proceedings of the Royal Society of London*, B122, 255-280.

Cross References

1.101 Range of visible energy in the electromagnetic radiation spectrum;

1.111 Luminous efficiency: effect of pupil entry angle;

1.301 Scotopic and photopic (rod and cone) vision;

1.305 Factors affecting sensitivity to light;

1.307 Absolute sensitivity to light: effect of target area and visual field location;

Handbook of perception and human performance, Ch. 5, Sect. 2.2

1.307 Absolute Sensitivity to Light: Effect of Target Area and Visual Field Location

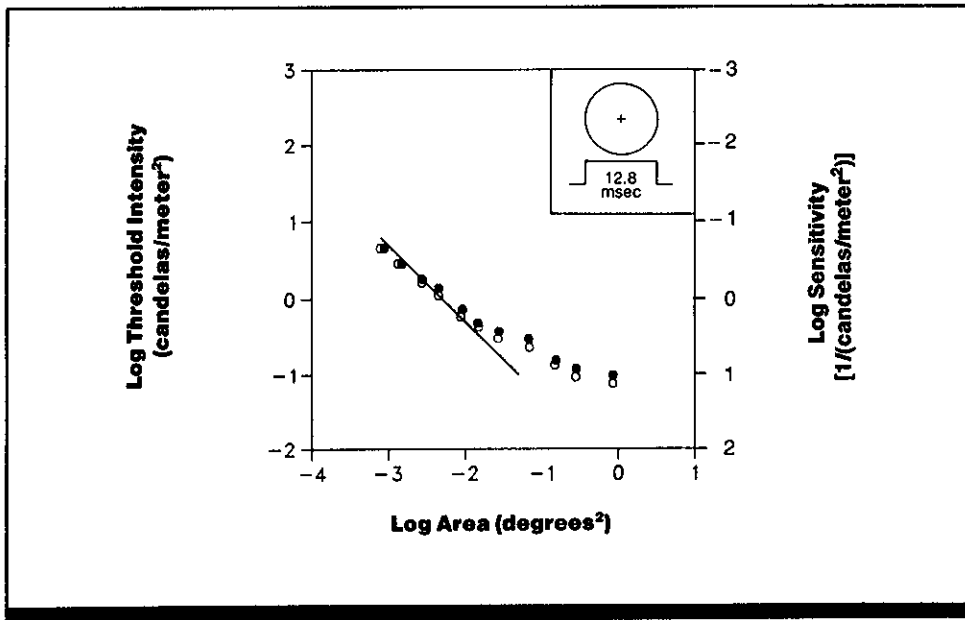

Figure 1. Log minimum detectable light intensity as a function of log area of test light. Red target light, shown in inset, presented to dark-adapted fovea (center of visual field). Data for two observers are represented by the open and filled circles. The line has a slope of -1 and indicates complete spatial summation (CRef. 1.307). (From *Handbook of perception and human performance*, based on data from Ref. 1)

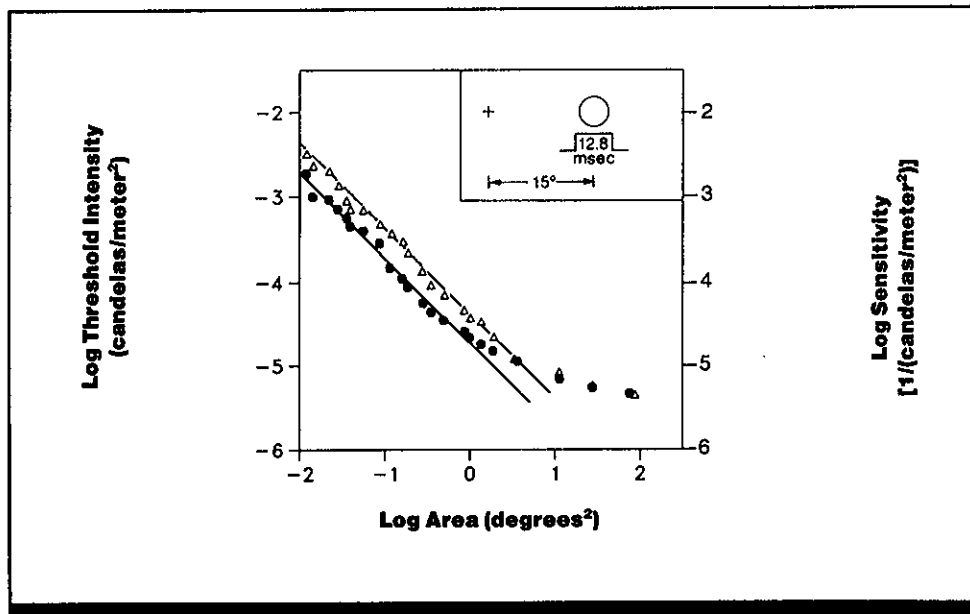

Figure 2. Log minimum detectable light intensity as a function of log area of test light. Red target light, shown in inset (cross = fixation point), presented to peripheral retina (15 deg nasal to fovea). Data for two observers are represented by the triangles and circles. The lines with slopes of -1 indicate complete spatial summation (CRef. 1.307). (From *Handbook of perception and human performance*, based on data from Ref. 1)

Key Terms

Critical size; foveal vision; peripheral vision; retinal location; size; spatial summation; visual field location; visual sensitivity

General Description

Absolute sensitivity to light (sensitivity of the dark-adapted eye) varies with target area and distance from the fovea (eye fixation). The light intensity required for detection decreases as target area increases up to a certain critical area. For foveal vision, spatial summation is complete

only for very small targets (diameters up to 6-7 min arc of visual angle). Spatial summation increases with distance from the fovea; for distances between 4 and 25 deg from fixation, summation occurs with target diameters <2.3 deg. As distance between target and fixation increases further, up to 39 deg, summation is complete for targets with diameters up to at least 4.7 deg.

Applications

Detection of dim targets is more likely if target is presented peripherally. For dim targets, increasing target size improves detectability more for targets in the peripheral than in the central visual field.

Methods

Test Conditions

- Foveal targets (Fig. 1, Ref. 1): observer light-adapted for 15 sec at 110 cd/m² (350 mL) then dark-adapted 105 sec prior to threshold measurement; target was red (Wratten filter 70, central wavelength 680 nm) light of 12.8 msec duration; target distance was 220 cm; monocular viewing through an aperture 1.5 deg in diameter, located in center of a dim (0.06 cd/m²) white screen
- Peripheral targets (Fig. 2, Ref. 1): observer dark-adapted 30 min, then gazed at foveal fixation point; target was red (Wratten filter 70, central wavelength 680 nm)

light of 12.8 msec duration; viewing distance 62 cm

- Peripheral targets (Fig. 3, Ref. 3): observer dark-adapted 45 min; target was 510 nm light presented for 10 msec every 4 sec

Experimental Procedure

- Ascending method of limits (Figs. 1 and 2)
- Independent variables: target area, target distance from fixation
- Dependent variable: threshold intensity
- 2 observers (Figs. 1 and 2) and 3 male observers, 20-30 yr (Fig. 3)
- Observer's task: indicate whether target was visible on each presentation

Experimental Results

- The intensity threshold is high (sensitivity is low) for small targets and threshold decreases as area increases, approaching a final limiting value.
- For foveal targets (Fig. 1), complete spatial summation (indicated by diagonal line with slope of -1.0) occurs only for small target areas ($< -2.0 \log \text{deg}^2$, or 6-7 min arc in diameter).
- For peripheral targets presented 15 deg nasally from fixation (Fig. 2), complete summation occurs for target diameters less than ~ 1 deg.
- Spatial summation increases with distance from the fovea (Fig. 3). At distances of 4-25 deg, the critical diameter below which spatial summation occurs is 2.3 deg. As distance from fixation increases further up to 39 deg, there is

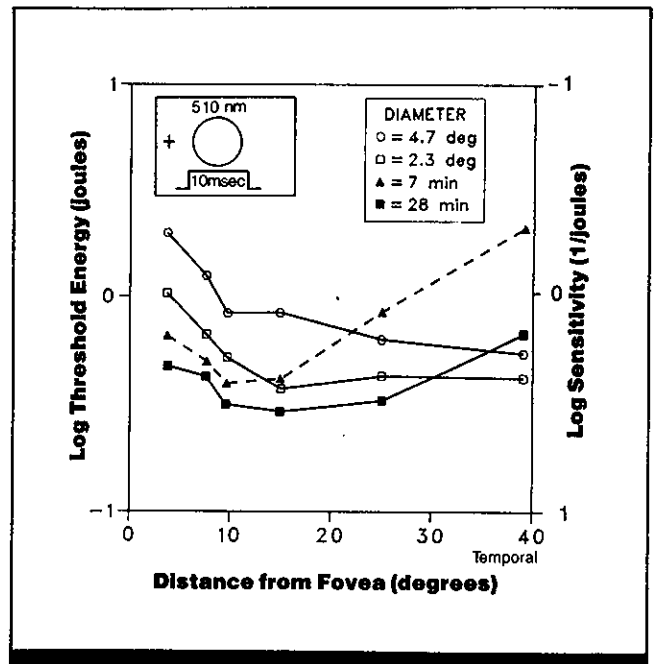

Figure 3. Log minimum detectable light energy as a function of distance from the fovea (fixation) for various target diameters. Green target light, shown in inset (cross = fixation point), presented to various locations of peripheral retina (~ 5 -40 deg temporal to fovea) (Ref. 3). Data for 1 observer. (From Ref. 3)

complete spatial summation for target diameters up to at least 4.7 deg.

- For the smallest target tested (7 min arc in diameter), thresholds increase between 15 and 40 deg (Fig. 3), a deviation from Ricco's Law (complete spatial summation) (CRef. 1.308).

Variability

No information on variability was given.

Constraints

- Many factors (including target duration and target wavelength) influence sensitivity to light and should be considered in applying these results under different conditions (CRef. 1.305).

Key References

*1. Graham, C. H., & Bartlett, N. R. (1939). The relation of size of stimulus and intensity in the human eye: II. Intensity thresholds for red

and violet light. *Journal of Experimental Psychology*, 24, 574-587.
2. Hallett, P. E. (1969). The variations in visual threshold measurement. *Journal of Physiology*, 202, 403-419.

*3. Scholtes, A. M. W., & Bouman, M. A. (1977). Psychophysical experiments on spatial summation at threshold level of the human peripheral retina. *Vision Research*, 17, 867-873.

Cross References

1.305 Factors affecting sensitivity to light;
1.306 Absolute sensitivity to light: effect of visual field location;

1.307 Absolute sensitivity to light: effect of target area and visual field location;
1.308 Spatial summation of light energy;

1.403 Brightness difference threshold: effect of background luminance and target size;
Handbook of perception and human performance, Ch. 5, Sect. 2.1

1.308 Spatial Summation of Light Energy

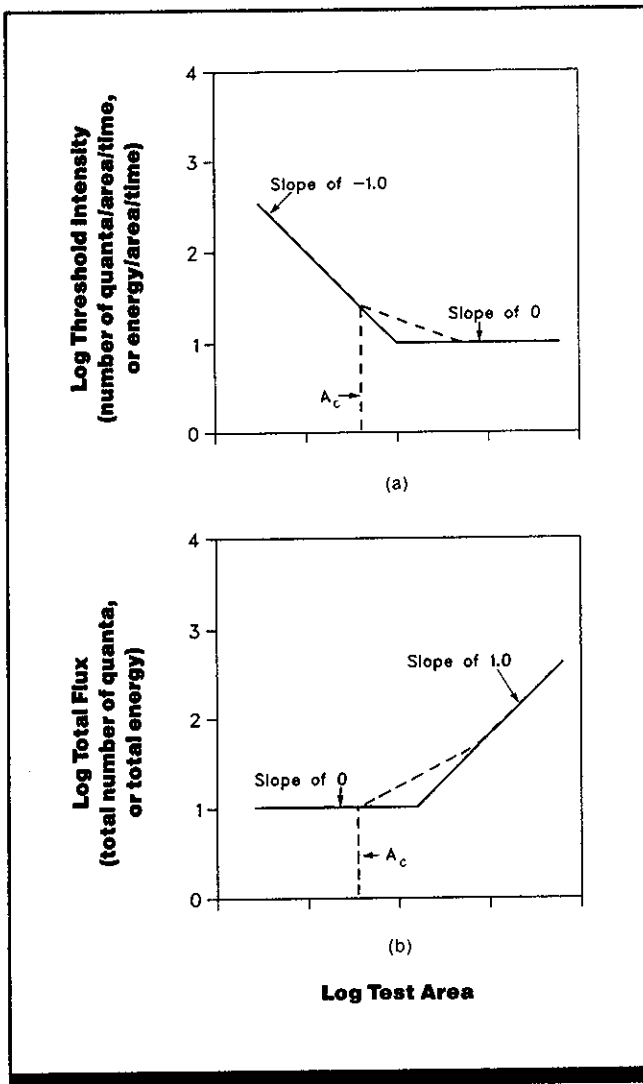

Figure 1. Schematic representation of spatial summation. (a) Log threshold intensity (quanta per unit area per unit time) as a function of log area of a target light. For small areas there is complete summation of energy over space, i.e., the equation holds. Threshold intensity varies inversely with changes in area and the data follow a slope of -1.0 . For very large areas, further increases in size produce no further summation, and threshold intensity is constant (slope of 0). Between the regions of complete summation and no summation is a region of partial summation (oblique dotted line). Here, increasing size improves sensitivity, but the improvement is less than expected from total energy integration. The point at which the data begin to deviate from complete summation is known as the critical area, or Ricco's area (A_c). (b) The function in panel (a) re-plotted in terms of the total energy (total number of quanta) required at threshold. The region of complete summation has a slope of 0 and the region of no summation, a slope of 1 (more total energy is required as area increases). The area of partial summation is indicated by the oblique dotted line. (From *Handbook of perception and human performance*)

Key Terms

Critical size; peripheral vision; Ricco's Law; scotopic vision; size; spatial summation; visual sensitivity

General Description

According to Ricco's Law, the lowest detectable intensity of light varies inversely with the area of the target light,

$$I = k/A$$

where I = threshold intensity in quanta per unit retinal area per unit time, A = target area, and k = a constant. In other words, the product of target area and target intensity at threshold is a constant ($I \times A = k$); that is, the total amount of light energy required for detection is the same, whether the energy is concentrated in a small area or is spread out over a larger area. This integration of the effects of light energy over stimulus area is termed *spatial summation*. When the observed relation between threshold intensity and target size follows exactly that of the equation, spatial summation is said to be complete; if the observed relation deviates

somewhat from that of the equation but threshold intensity still decreases with size, partial (or incomplete) spatial summation is said to occur.

Figure 1 shows a schematic rendering of spatial summation.

As shown in the figure, complete spatial summation of light energy occurs for small targets. As target area grows beyond a critical size, however, further increases in size produce no further decreases in threshold intensity. Between the regions of complete spatial summation and no summation, increasing target area improves sensitivity, but the improvement is less than expected from total energy integration. The size beyond which the relation begins to deviate from complete summation is known as the critical area or Ricco's Area.

Applications

Increasing target size improves the detectability of dim targets.

Methods

Spatial summation is typically studied using one of two basic paradigms. In the more common one, threshold is measured for a single

circular test spot of varying area. A decrease in the energy per unit area required for detection as test area increases indicates spatial summa-

tion. Another method uses two spatially separated test lights. The threshold for detecting the pair is measured as a function of the separation between the two lights. As

the test lights move close enough for spatial summation to occur, the light intensity per unit area required for detection will decrease.

Empirical Validation

Empirical investigations show complete spatial summation for small target areas in peripheral vision. However, the equation does not apply for large target diameters (little or no spatial summation occurs). Based on a review of the research in the area, Ref. 1 concludes that the largest target size for which complete spatial summation occurs (the critical size) varies with target location in the visual field, ranging from ~0.5-deg diameter for targets 5 deg from fixation

to ~2.0-deg diameter for targets 35 deg from fixation. However, complete summation has been found for target diameters as large as 4.7 deg in peripheral vision (CRef. 1.307). A few studies have reported critical areas as small as 10-20 min arc; these results have been attributed to the individual characteristics of the observers used (Ref. 1).

Very little spatial summation has been found in the fovea. The critical size for targets at fixation is ~6 min arc diameter.

Constraints

- The model applies to peripheral (**scotopic**) vision (**rod** system) only; there is little or no spatial summation in foveal (**photopic**) vision (**cone** system).

- The amount of spatial summation is influenced by target location in the field of view, target duration, and luminance level to which the eye is adapted (CRefs. 1.306, 1.307, 1.403).

Key References

1. Hallett, P. E. (1963). Spatial summation. *Vision Research*, 3, 9-24.

*2. Hood, D., & Finkelstein, M. (1986). Sensitivity to light. In

K. R. Boff, L. Kaufman, & J. P. Thomas (Eds.), *Handbook of perception and human performance: Vol. 1. Sensory processes and perception*. New York: Wiley.

Cross References

1.306 Absolute sensitivity to light: effect of visual field location;

1.307 Absolute sensitivity to light: effect of target area and visual field location;

1.403 Brightness difference threshold: effect of background luminance and target size;

1.408 Dark adaptation: effect of target size;

1.409 Dark adaptation: effect of spatial and temporal summation

1.309 Afterimages

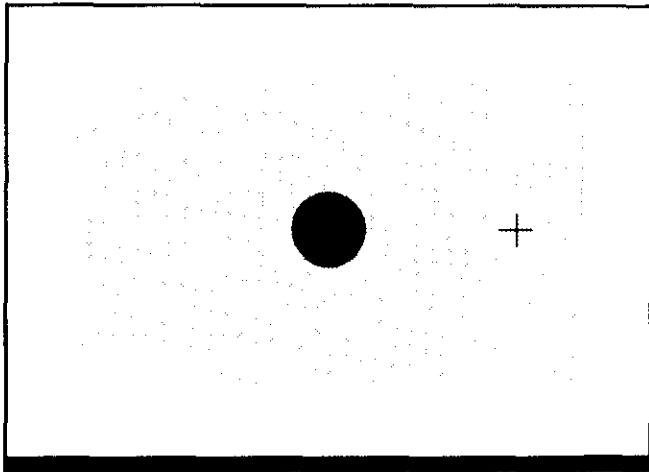

Figure 1. Demonstration of negative afterimage. Fixate on the black spot for 10-20 sec, then look at the fixation cross in the light gray surround to the right. A bright (white) afterimage in the shape of the spot will be visible. The same display can be used to demonstrate complementary afterimages for a colored stimulus. For example, if the spot was red, the afterimage seen against the gray surround would be green.

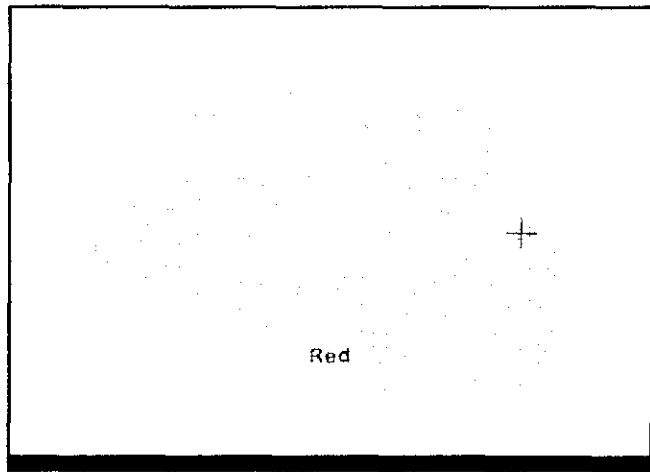

Figure 2. Display for demonstrating a homochromatic-like color afterimage. If an observer fixates a white spot in a red surround for 10-20 sec, then looks at a fixation cross in the red surround, an afterimage will be visible in the form of a more deeply saturated red spot.

Key Terms

Complementary afterimages; contingent aftereffects; homochromatic afterimages; McCullough effect; negative afterimages; positive afterimages

General Description

Simple Afterimages

Simple afterimages are seen under a variety of conditions when one visual stimulus field is followed by a second stimulus field. Figure 1 is a demonstration of the afterimage produced when fixation of a dark patch for 10-20 sec is followed by viewing a white field. Afterimages vary in hue, saturation, brightness, latency of appearance, duration, clarity, and form, depending upon the characteristics of the initial display (the *primary stimulus*), the characteristics of the subsequent test field (the *secondary stimulus*), and the state of visual system of the observer.

Afterimages are commonly classified as either *positive*, in which the afterimage and the primary stimulus have the same brightness relations to their surrounds, or *negative*, in which the brightness relation for the afterimage is opposite that for the primary stimulus. Color afterimages produced by a colored primary stimulus are further classified as *homochromatic afterimages*, which appear in the same hue as the primary stimulus, and *complementary afterimages*, which appear in a hue that is approximately complementary to that of the primary stimulus (complementary colors are pairs of colors that yield white when mixed in suitable proportions).

As a general rule, positive and homochromatic afterimages are very fleeting and occur within a second or two after termination of the primary stimulus. Negative and complementary afterimages, by contrast, are typically more durable and may last for 30 sec or more (Refs. 1, 2). The various types of afterimage often occur in complex sequences after a single primary stimulus, with alternating positive and negative afterimages giving way to a negative afterimage, or an initial homochromatic afterimage being replaced by a complementary afterimage.

Color afterimages are sometimes produced by viewing an achromatic primary stimulus. Figure 2 provides a demonstration of what happens when primary stimulus is a white disk in a colored surround. After fixating the primary stimulus for 10-20 sec, a shift in gaze to the surround produces an afterimage that is homochromatic with the surround but more saturated. This effect can be understood as an afterimage of a color induced in the white field color (CRef. 1.717). Color afterimages are also produced by exposure for several seconds to a bright white light. The result in this case is termed a *flight of colors*, because the afterimage goes through a sequence of color changes over a period of up to several minutes, beginning with green, moving through red and purple, and ending with blue (Ref. 5).

Contingent Afterimages

An intriguing kind of complementary afterimage known as the McCullough effect (Ref. 4) is produced by the primary stimulus displays and test field shown in Fig. 3. Inspection of the vertical and horizontal bar patterns (Figs. 3a, 3b) in slow alternation (for example, 10 sec each) for several minutes produces complementary afterimages in the test pattern, but these afterimages are contingent on line orientation. Thus, a green afterimage will be visible in the vertical lines of the test field (Fig. 3c) (the complementary afterimage for the primary stimulus in Fig. 3a), and a red afterimage will be visible in the horizontal lines of the test field (the complementary afterimage for the primary stimulus in Fig. 3b).

The McCullough effect differs from simple afterimages in several ways and probably involves different underlying mechanisms, although an accepted explanation of the effect is not available. Unlike simple afterimages, the McCullough effect does not require steady fixation on the primary stimulus. The effect is also extremely persistent, sometimes lasting for days.

Similar effects have been reported for color afterimages that are contingent on direction of movement, line width, and line curvature, as well as line orientation dimension as illustrated in Fig. 3.

Applications

Under normal conditions, simple afterimages do not intrude on visual processing. However, operators exposed to relatively bright flashes of light, especially at night, may experience afterimages and should be on guard against confusing these effects with actual events.

Constraints

- The sequence, latency, and duration of afterimages vary considerably among individuals.

Key References

*1. Brown, J.L. (1965). Afterimages. In C.H. Graham (Ed.), *Vision and visual perception* (pp. 479-503). New York: Wiley.

2. Burnham, R.W., Hanes, R.M., & Bartleson, C.J. (1963). *Color: A guide to basic facts and concepts*. New York: Wiley.

3. Hurvich, L.M. (1981). *Color vision* (pp. 175-176, plate 13-3). Sunderland, MA: Sinauer Associates.

4. McCullough, C. (1965). Color adaptation of edge-detectors in the human visual system. *Science*, *149*, 1115-1116.

5. Padgham, C. A. (1968). Measurements of the color sequences in positive visual afterimages. *Vision Research*, *8*, 939-949.

6. Stromeyer, C.F., III. (1972). Edge-contingent color aftereffects: Spatial frequency specificity. *Vision Research*, *12*, 717-733.

Cross References

1.717 Simultaneous color contrast;
1.718 Color assimilation;
1.719 Phantom colors;

6.318 Feature-selective adaptation and making;
6.320 Contingent aftereffects;
Handbook of perception and human performance, Ch.9, Sect. 4.3.3

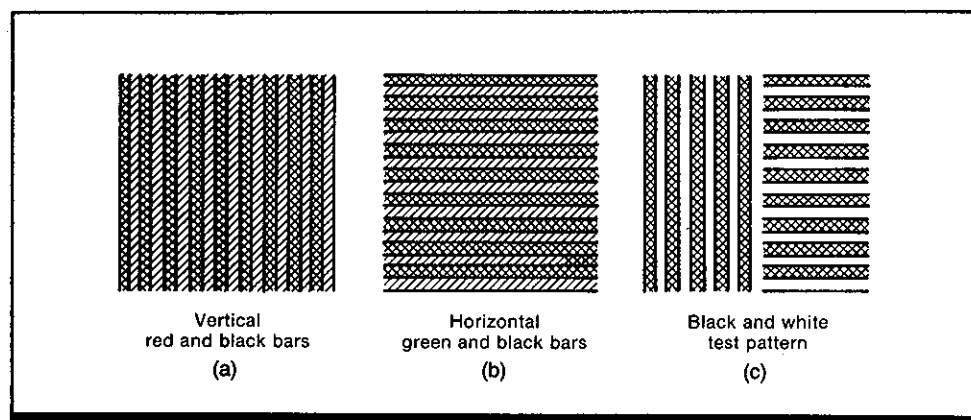
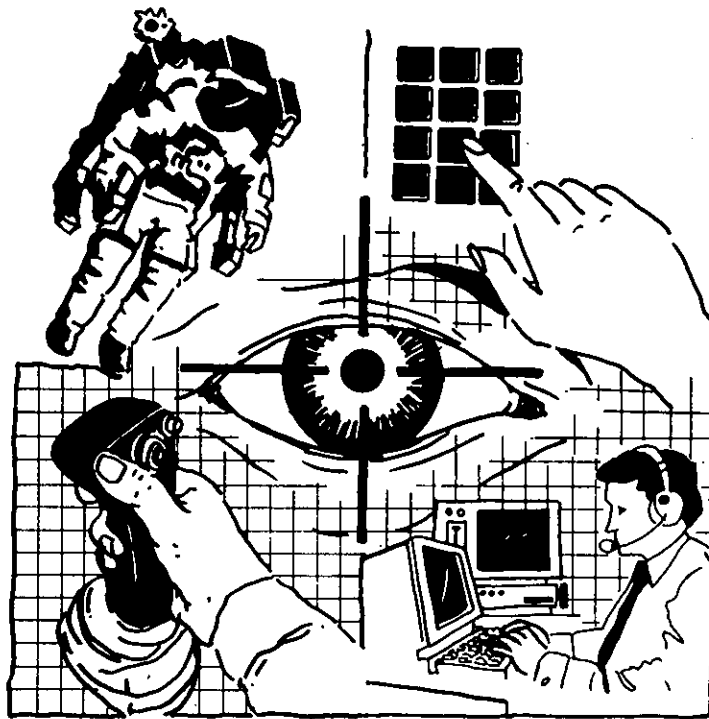

Figure 3. Visual display used to demonstrate the McCullough effect. The pattern of vertical red and black bars (a) and the pattern of horizontal green and black bars (b) are viewed alternately for 10 sec each for a period of 5-10 min. After this 5-10 min period, the black and white test pattern in (c) is viewed. Weak pale greens are perceived in the pattern of the vertical bars and weak pinks in the pattern of the horizontal bars. (From *Handbook of perception and human performance*)

Notes



Section 1.4 Adaptation: Changes in Sensitivity



1.401 Brightness Difference Threshold: Effect of Background Luminance

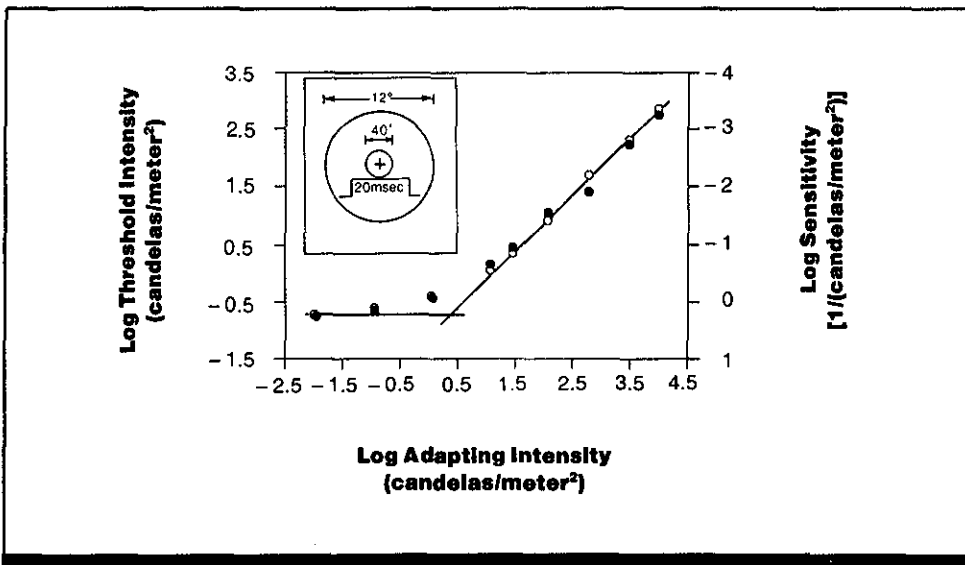

Figure 1. Threshold for detecting a test light presented against a bright background as a function of background (adapting) intensity (on log-log axes). Inset shows target configuration (cross indicates eye fixation). Data are given for 2 observers (filled and open circles). (From *Handbook of perception and human performance*, based on data from Ref. 1)

Key Terms

Brightness discrimination; light adaptation; light increment threshold; Weber-Fechner Law

General Description

When observers light-adapt to low levels of illumination (below $-1.0 \log \text{cd/m}^2$ [$-0.5 \log \text{trolands}$]), adaptation illuminance does not affect the intensity threshold for detecting a test light presented against the adapting back-

ground. At illuminances $>1 \log \text{cd/m}^2$, the illuminance difference threshold increases proportionately with increases in adapting illuminance. For intermediate adapting intensities, the threshold increases at an accelerating rate as adapting illuminance is raised.

Applications

Situations in which ambient illumination may vary; situations requiring detection of dim targets.

Methods

Test Conditions

- Two adapting intensities used per session; observer dark adapted for 10 min to higher intensity, then adapted 5 more min to lower adapting intensity
- Preliminary observations determined test intensities, which ranged from rarely seen to almost always seen

- Targets viewed monocularly through eyepiece with 2-mm artificial pupil; target was circular white light 40 min arc of visual angle in diameter in center of 12-deg white adapting field; 20-msec target duration
- Foveal target presentation; observer fixated center of adapting field
- Targets of varying intensity presented at rate of one per 10 sec until 10 observations made at each intensity

Experimental Procedure

- Method of constant stimuli
- Independent variable: intensity of adapting field
- Dependent variable: percent of time target detected (threshold defined as the intensity required to detect target on 60% of presentations)
- Observer's task: verbally indicate presence of target on each trial
- 2 observers

Experimental Results

- For adapting intensities up to about -1.0 cd/m^2 , the level of background illumination to which the observer is adapted has no effect on the size of the increment in illumination necessary for the observer to detect a test light superimposed on the adapting background (data fall on a slope of 0.0 in Fig. 1).
- At high adapting intensities, the increase in intensity difference threshold is proportional to the increase in adapting intensity. The data have a slope of 1.0, conforming to the Weber's law, $I_t = k \times I_a$, where I_a is the intensity of the adapting field, I_t is the amount by which the intensity of the

test light must be raised above I_a to be just detectable, and k is a constant.

- At intermediate intensities, the threshold increases at an accelerating rate.

Variability

No information on variability was given.

Repeatability/Comparison with Other Studies

Results are consistent with other empirical and theoretical work in vision.

Constraints

- The proportionate increase of threshold with adapting intensity may not hold for higher adapting intensities.
- Many factors influence sensitivity to light and should be considered in applying these results under different conditions (CRef. 1.305).

Key References

*1. Mueller, C. G. (1950). Frequency of seeing functions for intensity discrimination at various levels of adapting intensity. *Journal of General Physiology*, 34, 463-474.

Cross References

1.305 Factors affecting sensitivity to light;

1.403 Brightness difference threshold: effect of background luminance and target size;

1.626 Target detection: effect of prior exposure (adaptation) to a target of the same or different size;

Handbook of perception and human performance, Ch. 5, Sect. 3.2

1.402 Brightness Difference Threshold: Effect of Background Luminance and Duration of Luminance Increment

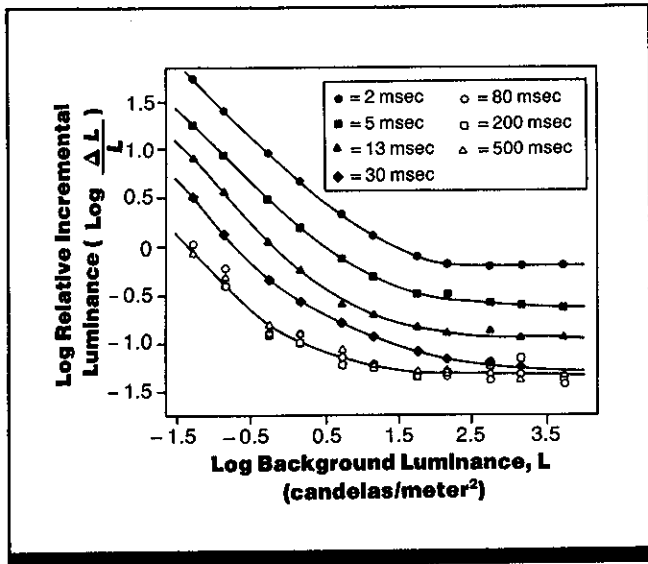

Figure 1. Proportional increase in luminance (ΔL) necessary to detect a target light superimposed on a bright background as a function of background luminance (L), for different target durations. (From Ref. 1)

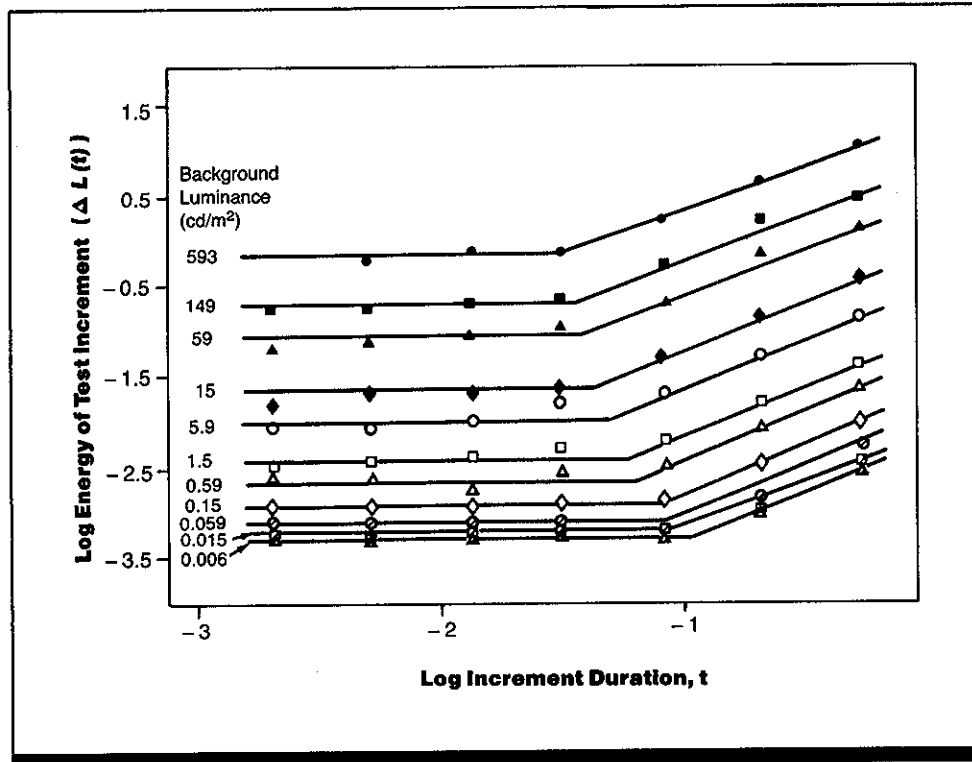

Figure 2. Light energy of the smallest detectable target luminance increment (ΔL) as a function of increment duration for different levels of background illumination (L). (From Ref. 1)

Key Terms

Bloch's Law; brightness discrimination; critical duration; light adaptation; light increment threshold; temporal summation

General Description

When a test light is superimposed on a bright background, the luminance increment necessary to discriminate the brightness difference depends on the luminance level of the background and the duration of the luminance increment (test flash). Up to some critical duration, the incremental luminance required for brightness discrimination decreases as

duration of the luminance increment increases (i.e., increments of equal light energy are equally detectable). At longer durations, there is no further **temporal summation** of light energy; increment duration has no effect and brightness discrimination depends on the luminance of the test light in relation to background luminance (i.e., increments of equal relative intensity are equally detectable).

Methods

Test Conditions

- Observer seated in darkness, viewing two semicircles 38-min arc of visual angle in radius separated by 8 min arc; viewing distance of 60 cm; configuration fell within foveal limits

- Test target 2 mm in diameter with slightly blurred edges superimposed on left semicircle at ~10-sec intervals; exposure duration of test target was 2-500 msec
- Luminous intensity of semi-circular background fields 0.006-593 cd/m² (0.00186 -186 mL)

- Binocular viewing with head held in place by headrest

Experimental Procedure

- Descending method of limits
- Independent variables: Background (adaptation) illumination, duration of test target

- Dependent variable: intensity difference threshold, expressed as the ratio of the difference in intensity between target and background to background intensity
- Observer's task: indicate whether target visible on each trial
- 8 threshold determinations per data point except 13 determinations for 0.03 sec duration

Experimental Results

- Brightness discrimination for a test light superimposed on a bright background (adapting field) may be measured as the logarithm of the **Weber ratio** ($\log \Delta L/L$, where L is the luminance of the background field and ΔL is the increase in luminance necessary to detect the test light). Brightness discrimination for the test light increases ($\log \Delta L/L$ decreases) as background luminance increases up to ~100 cd/m, and then remains fairly constant as luminance increases further.
- For a given background intensity, brightness discrimination is lowest ($\Delta L/L$ is highest) at short durations of the test light. The luminance increment required for brightness discrimination increases with duration for exposure durations ≤ 0.03 sec; for durations ≥ 0.08 sec, test light duration has no effect (results for durations of 0.08, 0.2, and 0.5 sec fall along the same curve in Fig. 1).

- Figure 2 replots the data to illustrate integration of light energy ($\Delta L \times t$) over time (temporal summation). At any given background luminance level, increasing the duration (t) of the luminance increment increases the detectability of the increment (ΔL decreases), up to some critical duration (i.e., $\Delta L \times t = \text{constant}$; seen in horizontal portion of curves with a slope of 0.0).
- After a critical duration that ranges from 0.03-0.1 sec, depending on background luminance level, target duration no longer has any influence, and brightness discrimination is determined entirely by the incremental luminance of the test flash ($\Delta L = \text{constant}$; oblique portion of curves with a slope of 1.0).
- Critical duration decreases as background luminance level increases.

Variability

No information on variability was given.

Constraints

- Temporal summation may vary with target size.
- Many factors influence sensitivity to light and should be considered in applying these results under different conditions (CRef. 1.305).

Key References

*1. Graham, C. H., & Kemp, E. H. (1938). Brightness discrimination as a function of the duration of the increment in intensity. *Journal of General Physiology*, 21, 635-650.

2. Hecht, S. (1935). A theory of visual intensity discrimination. *Journal of General Physiology*, 18, 767.

3. Hood, D. C., & Finkelstein, M. A. (1986). Sensitivity to light.

In K. R. Boff, L. Kaufman, & J. P. Thomas (Eds.), *Handbook of perception and human performance: Vol. 1. Sensory processes and perception*. New York: Wiley.

Cross References

1.305 Factors affecting sensitivity to light;

1.409 Dark adaptation: effect of spatial and temporal summation;

1.512 Time-intensity trade-offs in detection of brief targets: effect of duration, target intensity, and background luminance;

1.626 Target detection: effect of prior exposure (adaptation) to a target of the same or different size

1.403 Brightness Difference Threshold: Effect of Background Luminance and Target Size

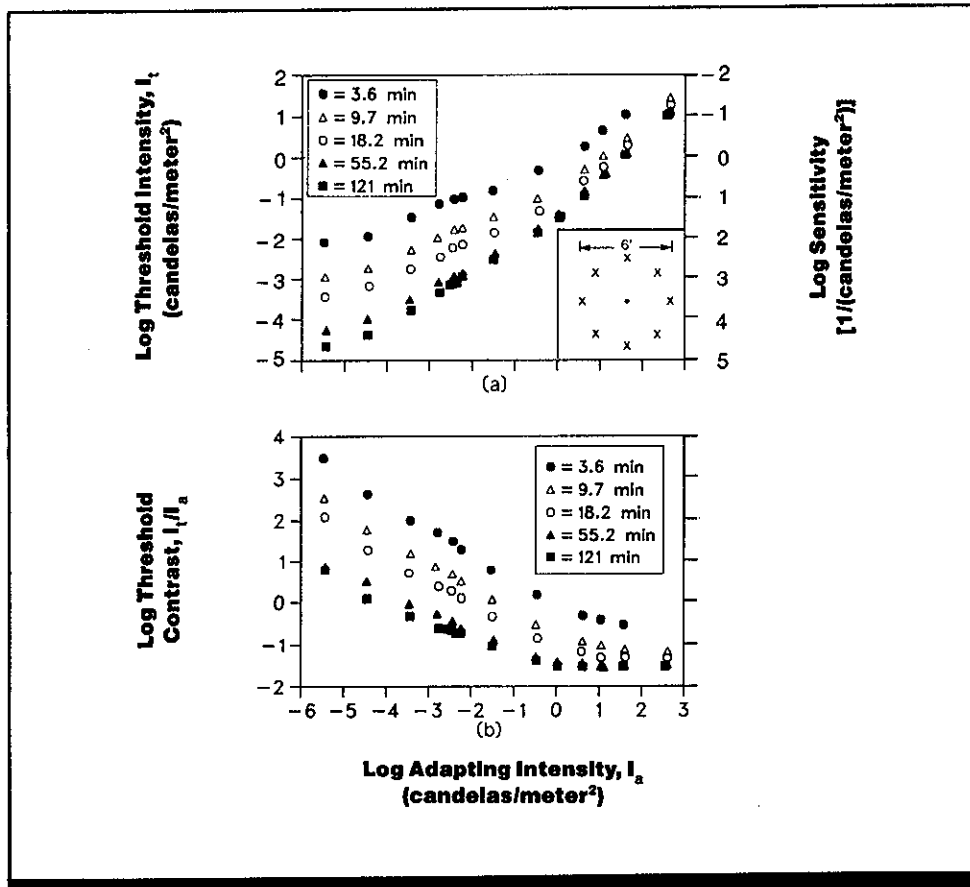

Figure 1. (a) Threshold intensity for detecting a target light against an adapting background for targets of five angular sizes. Inset shows possible locations of target light in relation to central orientation point. (b) The same data replotted in terms of target threshold contrast. Contrast is defined as I_t/I_a , where I_t is threshold intensity of the target and I_a is adapting (background) intensity. (From *Handbook of perception and human performance*, based on data from Ref. 1)

Key Terms

Brightness discrimination; light adaptation; light increment threshold; size; spatial summation; target size

General Description

The luminance required to detect a spot of light against a bright background increases monotonically as background (adapting) illumination increases. The intensity required for detection decreases as the size of the target increases.

Methods

Test Conditions

- Observers seated in illuminated white room
- Front wall of room, subtending 10 deg at observer's eyes, served as screen for presentation of targets; luminance of screen could be varied from 0-1000 fL; variations in luminance on screen did not exceed 3%

- Several observers seated at rear of observation room in upholstered chairs mounted on floor and on balcony
- Observers adapted to luminance level of observation room
- Target light 3.6-121 min arc in diameter delivered to any of eight positions on an imaginary circle, 6 deg diameter, with a small red orientation point at the center (see Fig. 1a)

Experimental Procedure

- Method of constant stimuli
- Independent variables: adapting intensity, target size
- Dependent variable: detection threshold, defined as target luminance required for 50% correct responses (adjusted for guessing). Data presented are average thresh-

olds determined over a 4-month period

- Observer's task: signal location in which target appeared
- 9 highly trained observers, ages 19-26

Experimental Results

- The threshold intensity for detecting a spot of light against a bright background increases (sensitivity decreases) as the luminance level of the background increases.
- The incremental luminance threshold decreases as target size increases.
- Contrast sensitivity (defined as the reciprocal of the ratio of target threshold intensity to background, or adapting, intensity) increases with increases in background illumination

up to ~ 1 cd/m². At higher levels, contrast sensitivity is relatively constant.

Variability

The 99% confidence interval for group data was $\pm 8\%$; the 50% confidence interval was $\pm 2\%$.

Repeatability/Comparison with Other Studies

Data are consistent with results of other research.

Constraints

- Fixation was not controlled. Sensitivity to light varies with target location in the field of view (CRef. 1.306; *Handbook*).

- Pupil size was not controlled. Effective retinal illuminance for a target of given size and luminance may therefore have varied across subjects and adapting conditions.
- Many factors affect sensitivity to light and must be considered in applying these data under different conditions (CRef. 1.305).

Key References

*1. Blackwell, H. R. (1946). Contrast thresholds of the human eye. *Journal of the Optical Society of America*, 36, 624-643.

Cross References

1.305 Factors affecting sensitivity to light;
1.306 Absolute sensitivity to light: effect of visual field location;

1.307 Absolute sensitivity to light: effect of target area and visual field location;
1.308 Spatial summation of light energy;

1.402 Brightness difference threshold: effect of background luminance and duration of luminance increment;

1.626 Target detection: effect of prior exposure (adaptation) to a target of the same of different size; *Handbook of perception and human performance*, Ch. 5, Sects. 3.1, 3.2

1.404 Intensity Difference Threshold: Effect of Luminance Increment Versus Decrement

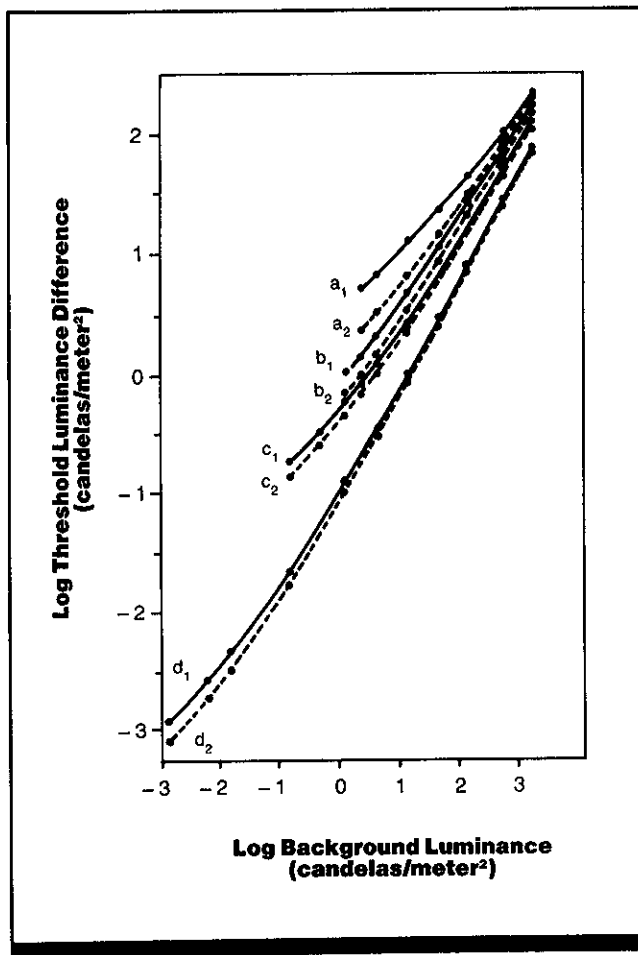

Figure 1. Log threshold luminance difference (smallest detectable luminance increment or decrement) as a function of log background luminance for targets of various sizes and durations. Subscript of 1 designates increment threshold; subscript of 2 designates decrement threshold. Target *a*: 15-min diameter, 50-msec duration; target *b*: 15-min diameter, 1000-msec duration; target *c*: 4.3-deg diameter, 20-msec duration; target *d*: 4.3-deg diameter, 1000-msec duration. (From Ref. 3)

Key Terms

Contrast; intensity difference threshold; target detection

General Description

The ability to detect changes in the luminance of a target viewed against a fixed background is greater when those luminance changes are presented as luminance decreases than when they are presented as increases; that is, thresholds for

detecting decreases in target luminance (decrement thresholds) are smaller than thresholds for detecting increases (increment thresholds). The advantage of decrements over increments, although never very large, is greatest for small targets of short durations at low background intensities.

Applications

Displays or situations in which the detectability of dim or low-contrast targets must be maximized.

Methods

Test Conditions

- Flickering disk (either 15 min or 4.3 deg in diameter) flashed once every 3 sec at 7 deg of visual angle from fovea in lower left quadrant of right eye; 2-mm diameter artificial pupil

- Duration of target: 20, 50, or 1000 msec
- Luminance of background: -3 to 3 log cd/m² of wavelength 507 mμ.
- Luminance of target increased above background in increment condition and decreased below background in decrement condition

- Subjects adapted to lowest background luminance for 30 minutes prior to testing

Experimental Procedure

- Method of adjustment
- Independent variables: duration of target flash, diameter of target, background luminance

- Dependent variable: difference threshold (smallest detectable increment or decrement in target luminance relative to background luminance)

- Observer's task: adjust intensity of target flash so that decision could be made, after a run of 10-20 flashes, that a stimulus was just visible most of the time
- 2 highly experienced observers

Experimental Results

- Increment thresholds are consistently higher than decrement thresholds irrespective of target size, duration, or background intensity.
- The superiority of decrement thresholds over increment thresholds is small. The difference between decrement and increment thresholds reaches a maximum of ~ 0.3 log units for the 15-min, 50-msec target at a mid-range background luminance. For larger targets, longer durations, and higher background luminances, the superiority of decrement thresholds declines.

Variability

No intra-observer variability reported. Results for the 2 observers were so similar that only the results on one were graphed.

Repeatability/Comparison with Other Studies

References 1 and 6 found the maximal advantage of decrement threshold over increment threshold to be 0.17 and 0.24 log units, respectively. References 2, 4, and 5, with no surround field and different observer tasks, found little difference between increment and decrement thresholds. For flickering targets, the decrement thresholds are generally smaller than the increment thresholds, but the difference is small.

Constraints

- Many factors can influence target detection and must be considered in applying these results to other viewing conditions (CRef. 1.624).

Key References

- | | | |
|--|---|--|
| <p>1. Boynton, R. M., Ikeda, M., & Stiles, W. S. (1964). Interactions among chromatic mechanisms as inferred from positive and negative increment thresholds. <i>Vision Research</i>, 4, 87-117.</p> | <p>2. Herrick, R. M. (1956). Foveal luminance discrimination as a function of the duration of the decrement or increment in luminance. <i>Journal of Comparative Physiology</i>, 59, 437-443.</p> <p>*3. Patel, A. S., & Jones, R. W. (1968). Incremental and decremental visual thresholds. <i>Journal of the Optical Society of America</i>, 58, 696-699.</p> | <p>4. Rashbass, C. (1970). The visibility of transient changes of luminance. <i>Journal of Physiology</i>, 210, 165-186.</p> <p>5. Roufs, J. A. J. (1974). Dynamic properties of vision. IV. Thresholds of decremental flashes, incremental flashes and doublets in relation to flicker fusion. <i>Vision Research</i>, 14, 831-851.</p> <p>6. Short, A. D. (1966). Decremental and incremental visual thresholds. <i>Journal of Physiology</i>, 185, 646-654.</p> |
|--|---|--|

Cross References

- | | | |
|---|---|---|
| <p>1.401 Brightness difference threshold: effect of background luminance;</p> | <p>1.402 Brightness difference threshold: effect of background luminance and duration of luminance increment;</p> | <p>1.403 Brightness difference threshold: effect of background luminance and target size;</p> <p>1.624 Factors affecting detection of spatial targets</p> |
|---|---|---|

1.405 Time Course of Light Adaptation

Key Terms

Foveal vision; light adaptation; light increment threshold; peripheral vision; photopic vision; scotopic vision

General Description

After an increase in the level of illumination (**adaptation level**), the visual system takes time to adjust to the change in light intensity. For **foveal (cone)** stimulation, sensitivity is lowest (threshold is highest) immediately after onset of the adapting light; sensitivity increases (threshold decreases) with continued exposure to the adapting field (although not necessarily monotonically, especially at high adapting intensities). The recovery in sensitivity is rapid for low adapting intensities, but may take 10 min or more to reach completion for more intense adapting fields. For **peripheral (rod)** vision, sensitivity is lowest immediately after onset of the adapting light, then rises rapidly within the first 200 msec and more slowly through the rest of the first minute of adaptation.

Methods

1-deg centrally located light flash 20 msec in duration; white light used throughout

Test Conditions

Peripheral Stimulation (Ref. 1)

- Observer first dark-adapted, with head fixed by bite bar, then viewed adapting field
- Adapting field was 11 deg of visual angle in diameter, red (Wratten filter 26, 621-nm), field at 0.3 cd/m², presented for 400 msec; and target was blue (480 nm) 4.5-deg square target flash presented 12 deg from fixation for 30 msec
- Stimulus configuration presented in Maxwellian view, with target entering through nasal edge of pupil
- Observer's pupils dilated with Mydracyl or Cyclogel

Foveal Stimulation (Ref. 2)

- Adapting field intensity varied from 1.86-1860 cd/m²; target was

Experimental Procedure

Peripheral Stimulation

- Method of adjustment
- Independent variable: time since onset of adapting field
- Dependent variable: intensity difference threshold
- Observer's task: indicate whether target was visible on each trial
- 1 observer

Foveal Stimulation

- Method of limits
- Independent variables: time since onset of adapting field, intensity of adapting field
- Dependent variable: intensity difference threshold
- Observer's task: indicate whether target was visible on each trial
- 2 observers

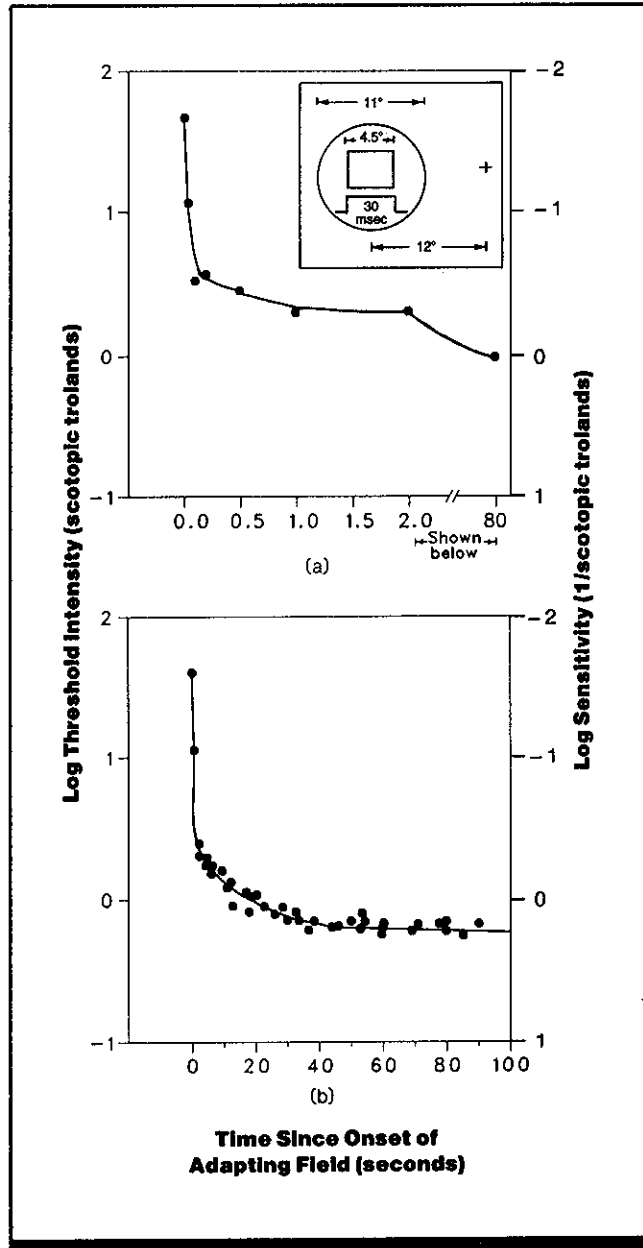

Figure 1. Increment in intensity required to detect a test light superimposed on an adapting background as a function of time since onset of adapting field, for peripheral (rod) vision. Inset shows stimulus configuration (cross = eye fixation). Adapting intensity was 0.3 cd/m². The two panels show the same data plotted on different time scales. (From Ref. 1)

Repeatability/Comparison with Other Studies

When sensitivity is measured by the absolute threshold method or the comparison method (rather than increment threshold method as here), sensitivity for foveal vision is found to decrease during light adaptation.

Experimental Results

- Time course of adaptation for peripheral visual field shows that sensitivity is lowest (threshold is highest) at the onset of the adapting background field and decreases rapidly within the first 200 msec of exposure to the field. This is followed by a more gradual decrease in threshold lasting through the rest of the first minute of light adaptation.
- For foveal adaptation, sensitivity increases rapidly (threshold drops) during the first ~3 min and then levels off. Especially at the highest adapting intensity, after the initial increase in sensitivity, there is a very small drop in sensitivity before the final level is reached.

Variability

No information on variability was given.

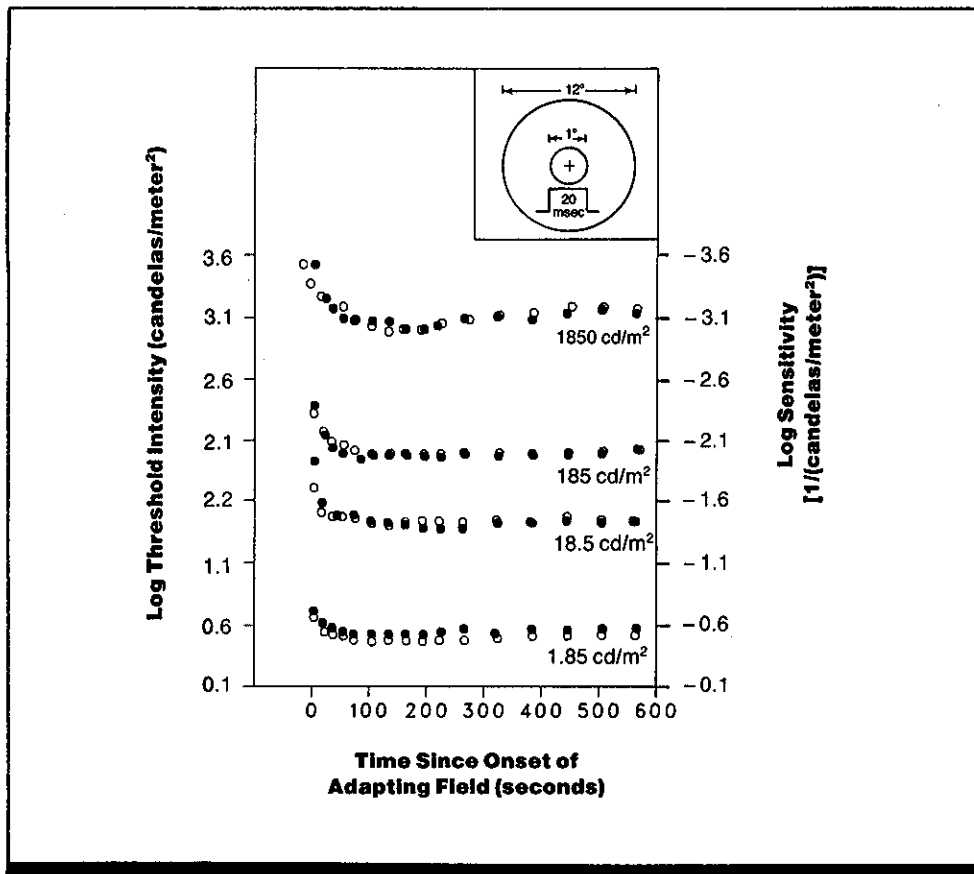

Figure 2. Increment in intensity required to detect a test light superimposed on an adapting background as a function of time since onset of adapting field, for foveal (cone) vision at four adaptation levels. Inset shows stimulus configuration (cross = eye fixation). Data are averages from 2 observers. (From *Handbook of perception and human performance*, based on data from Ref. 2)

Constraints

- The data may not be valid for other measures of sensitivity.
- Many factors influence sensitivity to light and should be considered in applying these results under different conditions (CRef. 1.305).

Key References

*1. Adelson, E. H. (1982). Saturation and adaptation in the rod system. *Vision Research*, 22, 1299-1312.

*2. Baker, H. D. (1949). The course of foveal light adaptation measured by the threshold intensity increment. *Journal of the Optical Society of America*, 39, 172-179.

Cross References

1.305 Factors affecting sensitivity to light;

Handbook of perception and human performance, Ch. 5, Sect. 3.2

1.406 Factors Affecting Dark Adaptation

Key Terms

Dark adaptation; field of view; light increment threshold; size; visual sensitivity; wavelength

General Description

When stimulated by light, the visual system progressively loses sensitivity. In the dark, sensitivity recovers, a process known as dark adaptation. The change in sensitivity may be very large; after a half-hour in the dark, the visual system

may respond to light of only about a hundred-thousandth the intensity required immediately after offset of the background light. The table summarizes factors that influence the rate and degree of dark adaptation.

Constraints

- Interactions may occur among the various factors affecting the rate and amount of dark adaptation.

Factor	Effect on Dark Adaptation	References
Time in dark	Adaptation occurs in two phases: initial rapid stage (~5 min) due to cone adaptation, and a slower stage (~30-35 min) due to rod adaptation	Ref. 1
Duration of adaptation	For peripheral (rod) vision, up to ~4 min, the longer the pre-exposure to light, the longer the recovery time in the dark. For foveal (cone) vision, the effect is smaller beyond ~2 min	CRef. 1.413
Intensity of adapting light	Rate of dark adaptation is slower after exposure to higher intensity light than after exposure to lower intensities	CRef. 1.411
Size of adapting light	For foveal (cone) vision, dark adaptation is slower if test and adapting fields are small or close in size than for larger fields of equal energy	CRef. 1.412
Wavelength of adapting light	Rate and amount of dark adaptation may vary depending on the wavelength of the adapting light, reflecting the differential sensitivity of the rod and cone systems to different wavelengths Rod (peripheral) dark adaptation is more rapid after preadaptation to only long wavelengths	CRef. 1.407 Ref. 2
Target size	With increasing time in dark, the ability to detect a large target (≥ 1 deg) shows greater and faster improvement than the ability to detect a small target Difference in dark adaptation for small and large fields is minimal after 150 sec (by which time dark adaptation is close to complete)	CRef. 1.409
Spatial frequency of target	Resolution of fine detail improves rapidly with time in dark up to ~7-10 min Resolution of coarse detail continues to improve over ~30 min	CRef. 1.410
Duration of test target	With increasing time in dark, the ability to detect a target presented for a long duration (up to ~100-200 msec) improves more rapidly and to a larger extent than the ability to detect a target presented more briefly	CRef. 1.409

Key References

*1. Beebe-Center, J. G., Carmichael, L., & Mead, L. C. (1944). Daylight training of pilots for night

flying. *Aeronautical Engineering Review*, 3, 9-29.

2. Geldard, F. A. (1972). *The human senses*. New York: Wiley.

Cross References

1.407 Dark adaptation: effect of wavelength;

1.409 Dark adaptation: effect of spatial and temporal summation;

1.410 Visual resolution during dark adaptation;

1.411 Dark adaptation following exposure to light of varying intensity;

1.412 Dark adaptation following exposure to light fields of varying size;

1.413 Dark adaptation following exposure to light of varying duration

1.407 Dark Adaptation: Effect of Wavelength

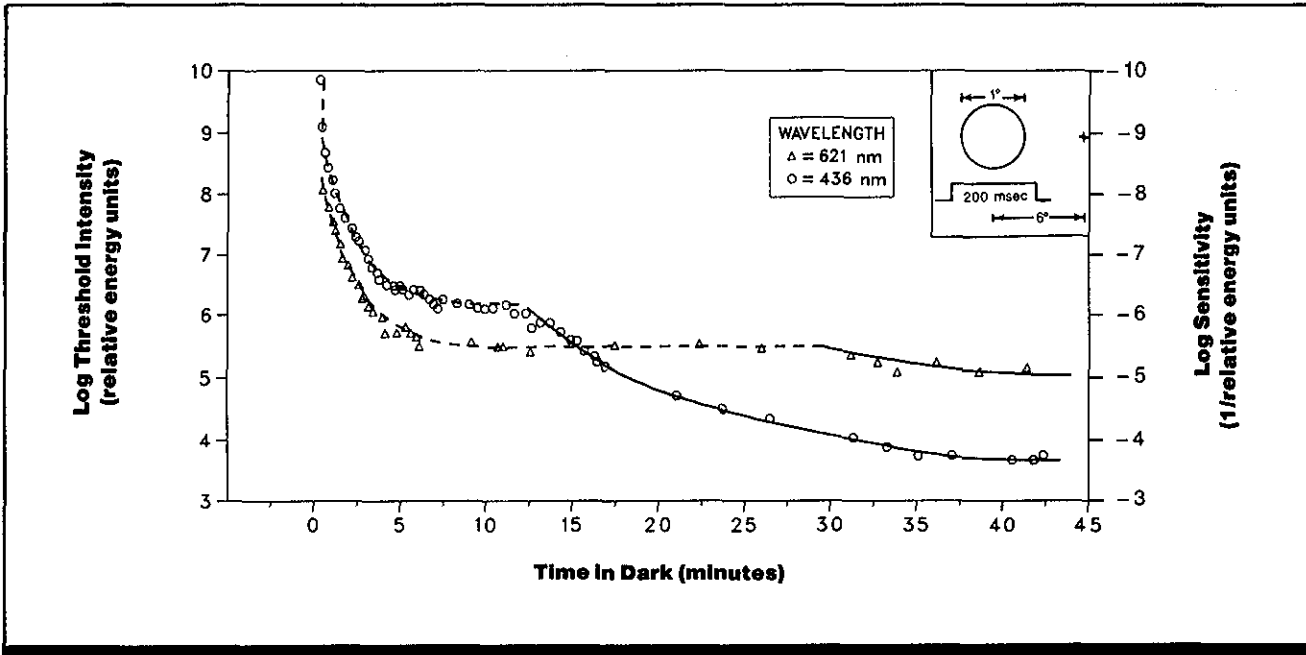

Figure 1. Threshold for test lights of different wavelengths as a function of time in dark since offset of an adapting field. Inset shows target configuration (cross = fixation point). The dashed line is a dark-adaptation function for cone vision derived from the data for the 621 nm (orange) test target; solid line is dark-adaptation function for rod vision derived from the data for the 436 nm (violet) test target (see text). (From Ref. 1)

Key Terms

Dark adaptation; visual sensitivity; wavelength

General Description

After a preadapting light field is turned off, detection threshold for a test light decreases (sensitivity increases) with time in the dark (dark adaptation). Detection thresholds for orange and violet targets in the dark display a rapid

fall to a plateau followed by a second, slower decline to a final plateau. The first drop reflects the adaptation of cones, the second of rods. Cones are more sensitive to orange targets than to violet targets, while rods are more sensitive to violet targets.

Applications

The relative sensitivity to long- and short-wavelength illumination varies with time in the dark. Thus, a long-wavelength target may appear brighter than a short-wavelength target during early dark adaptation, but the relative brightness will reverse as adaptation proceeds.

Methods

Test Conditions

- Observer preadapted with very bright white light, 1.6×10^6 cd/m² (5.0×10^5 mL), for 5 min; testing began immediately after offset

of preadapting light; test target was orange (621 nm) or violet (436 nm); target subtended 1 deg of visual angle and was presented for 200 msec

- Targets presented 6 deg from eye fixation

Experimental Procedure

- Thresholds measured with spectral adaptometer (Ref. 1)
- Independent variables: wavelength of target; time in dark

- Dependent variable: intensity of target necessary for detection (threshold)
- Observer's task: indicate whether target was seen
- 1 observer

Experimental Results

- Absolute sensitivity to light increases (threshold decreases) with time in the dark following offset of a white preadapting field.
- When the test light used to measure detection threshold is violet, threshold decreases rapidly during the first ~5 min in the dark, reaches a plateau, and then shows a second, slower decrease after ~13 min to a second plateau.
- For orange test lights, threshold also falls rapidly during the first 5 min, but then remains as a plateau for ~30 min, following which another slight decline in threshold is seen.
- The upper branch of each curve (Fig. 1) is assumed to represent dark-adaptation of the cone system, while the lower branch (second rapid drop in threshold following first plateau) is assumed to reflect dark adaptation of the rod system.
- As indicated by the crossing of the two curves, for test lights of equal luminance, the orange light appears brighter than the violet light during the first ~15 min of dark adaptation; thereafter, the situation reverses, and the violet light appears brighter (the latter is known as the Purkinje shift) (CRef. 1302).

Constraints

- The cone plateau may vary with the intensity of the preadapting light and the observer's task.
- The data may be valid only when preadaptation is with white light.

Key References

*1. Auerbach, E., & Wald, G. (1954). Identification of a violet receptor in human color vision. *Science*, 120, 401-405.

Cross References

1.302 Spectral sensitivity;
1.406 Factors affecting dark adaptation;
Handbook of perception and human performance, Ch. 5, Sect. 4.2

- The dashed curved for the violet test light (Fig. 1) is the cone system dark-adaptation curve derived from the data for the orange light and shifted to coincide with data of the violet light. Likewise, the solid line representing dark-adaptation for the rod system fit to the data for the violet test light has been shifted to coincide with the data for the orange light. The fact that the dark-adaptation curves derived from data for one wavelength fit well the data for the second wavelength supports the duplicity theory of dark adaptation. According to this theory, the shapes of the dark adaptation function for each system remains constant regardless of wavelength; thus, the overall time course of dark adaptation for test light of any given wavelength can be determined from the shapes of the individual rod and cone adaptation functions and the spectral sensitivities of the rods and cones.

Variability

No information on variability was given.

-
- Many factors affect dark adaptation and should be considered in applying these results under different conditions (CRef. 1.406).

1.408 Dark Adaptation: Effect of Target Size

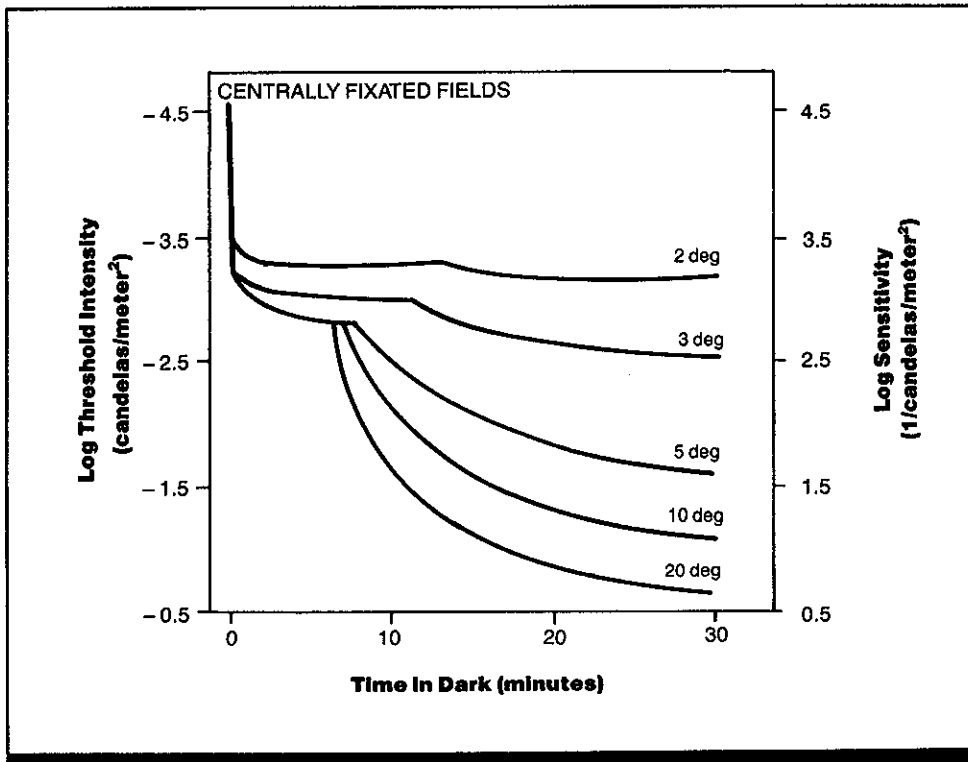

Figure 1. Detection threshold as a function of time in the dark for centrally fixated targets of different size. Representative data from 1 observer are shown. (Adapted from Ref. 1)

Key Terms

Dark adaptation; foveal vision; peripheral vision; size; spatial summation; visual sensitivity

General Description

After a preadapting light is turned off, threshold for detecting a test light decreases (sensitivity to light increases) with time in the dark. This **dark adaptation** generally shows two stages: there is an initial rapid decrease in threshold which may be followed by a plateau, and then a second slower, larger decline in threshold. With targets presented

to the center of the visual field, the two stages of adaptation change differently as the size of the test target increases. With small targets, the first stage dominates. As target size increases, to include more peripheral areas of the retina with greater light sensitivity, the second stage appears sooner and threshold declines to lower values.

Applications

In situations requiring detection of dim targets, both target size and the observer's state of dark adaptation must be considered in predicting observer performance level.

Methods

Test Conditions

- Observer light-adapted for 2 min to a brightness of 955 cd/m² (300 mL); threshold measurements begun immediately after offset of adapting field; **fixation point** provided during testing
- Test field was opal glass plate illuminated by 2.8-V, 0.28-amp lamp; target diameter 2-20 deg; target centered on fixation point

- Target viewed through 2.85-mm exit pupil located 10 cm from eye; accommodation assisted by lens
- Threshold measurements made by having observer adjust position of **neutral density** wedge to change intensity until test target was just visible, usually 2-3 exposures; in first few minutes of dark adaptation, measurements made as rapidly as possible; later measurements made every 2-5 min
- Measurements made with right eye

Experimental Procedure

- Method of adjustment under observer's control
- Independent variables: time in dark, target diameter
- Dependent variable: detection threshold
- Observer's task: adjust target intensity until target just visible
- Each data point is the average of 3-7 trials at each target diameter
- 3 observers

Experimental Results

- After ~5 min of dark adaptation, for a given number of minutes in the dark, the threshold for light decreases (sensitivity increases) as the size of the test target increases.
- During the first 2-3 min in the dark, threshold drops rapidly for all sizes of test target.
- For the 2-deg test target, after this initial drop the threshold remains nearly constant for ~15 min, after which only a slight additional drop appears.
- With larger targets, this secondary drop is greater and appears sooner because the peripheral retina is more light-sensitive than the central retina.
- The small, rapid decrease in threshold (upper branch of curve) is assumed to be associated with **cone** function and

the slower, larger decrease (lower branch of curve) with **rod** function.

Variability

Data for a second observer were virtually identical to those in Fig. 1. Thresholds for a third observer were identical for large targets; for the small targets, the thresholds were 0.3-0.7 log units lower. Reference 1 reports that data from occasional runs with other observers suggest that the present data cover the normal range of variation.

Repeatability/Comparison with Other Studies

Transition between the two stages of dark adaptation is consistent with previous research and with known anatomical properties of the eye.

Constraints

- When tests targets are restricted to the **fovea** (very center of the visual field), the dark adaptation function shows no lower branch.
- Many factors affect dark adaptation and should be considered in applying these results under different conditions (CRef. 1.406).

Key References

*1. Hecht, S., Haig, C., & Wald, G. (1935). The dark adaptation of retinal fields of different size and location. *Journal of General Physiology*, 19, 321-337.

Cross References

- 1.308 Spatial summation of light energy;
- 1.406 Factors affecting dark adaptation;
- 1.409 Dark adaptation: effect of spatial and temporal summation

1.409 Dark Adaptation: Effect of Spatial and Temporal Summation

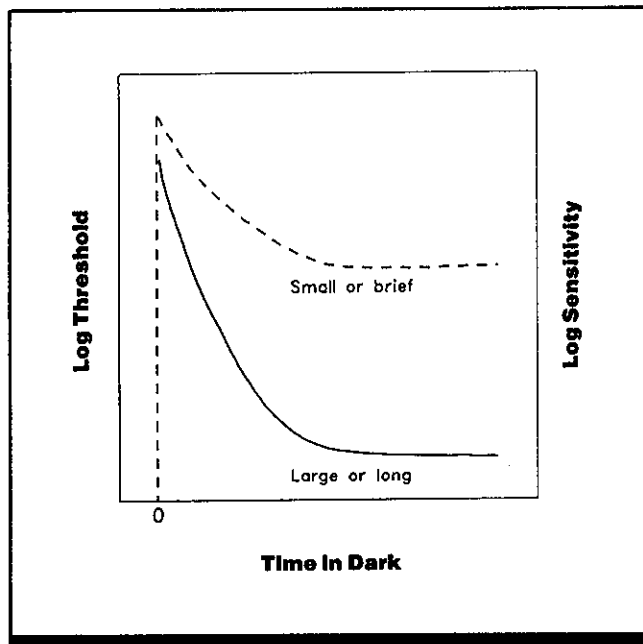

Figure 1. The effect of spatial and temporal summation on the dark-adaptation function. The hypothetical curves show the decrease in detection thresholds with time in the dark for test lights of two sizes or durations: small or brief (dashed curve) and large or long duration (solid curve). (0 indicates offset of illumination.) (From Ref. 3)

Key Terms

Dark adaptation; size; spatial summation; temporal summation; visual sensitivity

General Description

Following entry into a dark environment, the visual system adjusts by becoming more sensitive to light. This progressive increase in sensitivity with time in the dark is termed *dark adaptation*. The ability of the visual system to integrate (sum) target luminance over space and time increases during dark adaptation. Dark adaptation functions vary with changes in the size and duration of the test light used to measure sensitivity. With time in the dark, curves reflecting ability to detect small or briefly presented targets diverge from those indicating ability to detect larger targets or those presented for a longer duration.

Figure 1 shows hypothetical curves for the recovery of sensitivity with time in the dark for these two types of tar-

gets. Immediately after the offset of illumination, thresholds for all targets are high and nearly equal, regardless of size or duration. As time increases thresholds drop more rapidly (sensitivity increases faster) for large or long targets than for small or brief targets, so that after several minutes in the dark, large/long targets are much more detectable than small/brief targets.

No numerical values are given on the axes of Figure 1, since both absolute threshold for light and the time course of threshold changes in the dark may vary substantially, depending on target characteristics and test conditions (CRefs. 1.305, 1.406). Complete recovery of sensitivity in the dark may take anywhere from a few seconds to 30-35 min, depending on a previous illumination level and other factors.

Applications

The rate and amount of improvement in sensitivity during dark adaptation depend upon the size and duration of the target to be detected. Early in dark adaptation, using a large target or a target presented for a longer duration is less advantageous than later in dark adaptation.

Empirical Validation

The model is consistent with much data on dark adaptation, **spatial summation**, and **temporal summation**.

Constraints

- Changes in spatial summation of light in the peripheral visual field (**rod system**) are larger and slower than changes in the central (**foveal**) field (**cone system**); changes in spatial summation for central vision are relatively small and complete within ~100 sec.
- There is no further spatial summation for test lights larger than ~1-deg diameter (CRef. 1.308).

- The ability of the visual system to integrate light energy over time increases quickly during dark adaptation; early in the dark adaptation period, the visual system can integrate over ~30-40 msec, while after complete dark adaptation, integration occurs over 100-200 msec. Beyond this duration, no further temporal summation occurs (CRef. 1.512).
- Many factors affect dark adaptation and should be considered in applying these results under different conditions (CRef. 1.406).

Key References

1. Arden, G. B., & Weale, R. A. (1954). Nervous mechanisms and dark adaptation. *Journal of Physiology*, 125, 417-426.

2. Crawford, B. H. (1937). The change of visual sensitivity with time. *Proceedings of the Royal Society*, 129B, 94-106.

3. Hood, D. C., & Finkelstein, M. A. (1986). Sensitivity to light.

In K. R. Boff, L. Kaufman, & J. P. Thomas (Eds.), *Handbook of perception and human performance: Vol. 1. Sensory processes and perception*. New York: Wiley.

4. Montellese, S., Brown, J. L., & Sharpe, L. T. (1979). Changes in critical duration during dark adaptation. *Vision Research*, 10, 1147-1153.

Cross References

1.305 Factors affecting sensitivity to light;
1.308 Spatial summation of light energy;

1.406 Factors affect dark adaptation;

1.408 Dark adaptation: effect of target size;

1.512 Time-intensity trade-offs in detection of brief targets: effect of duration, target intensity, and background luminance

1.410 Visual Resolution During Dark Adaptation

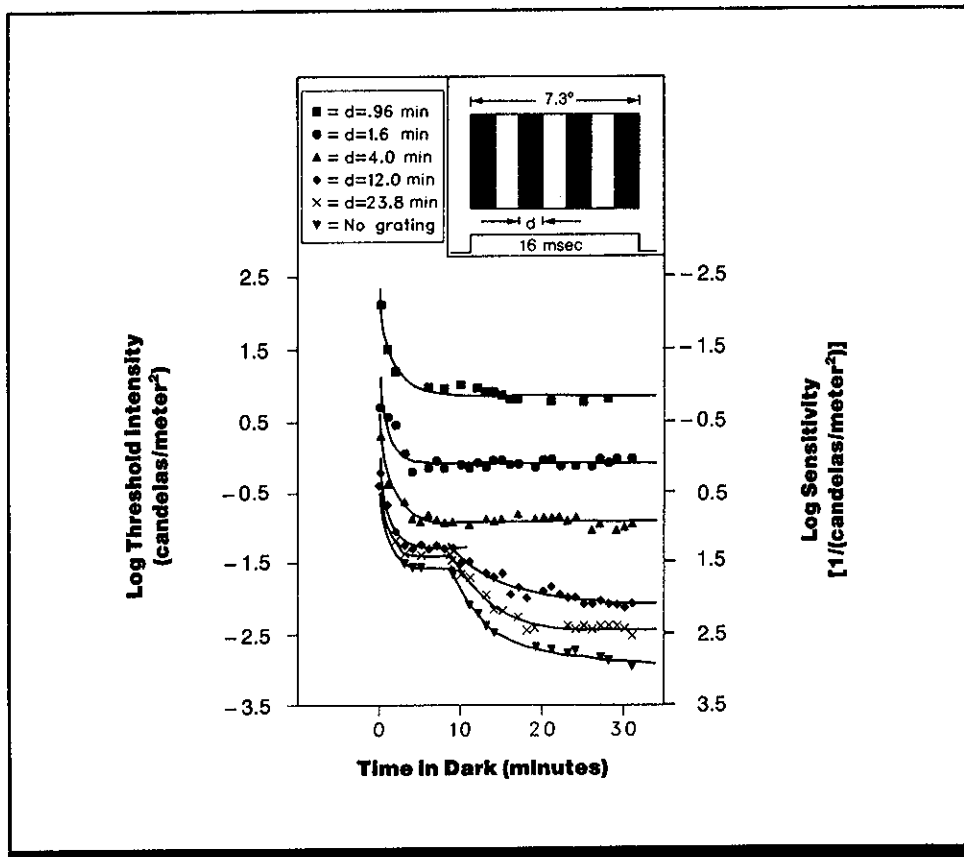

Figure 1. Luminance thresholds for resolution of bar patterns (square-wave gratings) of various angular bar widths as a function of time in the dark. "No grating" condition shows thresholds during dark adaptation for detecting a homogeneous (blank) test target. Data from 1 observer. (From Ref. 1)

Key Terms

Dark adaptation; size; spatial resolution; visual acuity

General Description

Luminance thresholds for the visual resolution of bar patterns (square-wave gratings) of various widths decrease (sensitivity increases) with time in the dark after the offset of a preadapting light (dark adaptation). Resolution of fine

detail (small bar widths) improves rapidly with time in the dark, with maximum sensitivity reached in 7-10 min. Coarser targets produce a dual-branched (or two-phase) adaptation curve, revealing continued improvement in visual resolution over ~30 min.

Applications

Selection of display image size for conditions of low illumination.

Methods

Test Conditions

- After 5-min adaptation to a 3.7-log cd/m² (1500 mL) white light, observer viewed square-wave gratings of various bar widths (0.96-23.8 min arc) and orientations; total test field subtended 7.3 deg of visual angle

- Targets presented to center of visual field for 16 msec, one target per min; targets presented alternately to left and right eyes
- Warning signal given prior to test flash
- Targets viewed through 3-mm artificial pupil of eyepiece of adaptometer

Experimental Procedure

- Method of constant stimuli
- Independent variables: time in dark, bar width of square-wave grating
- Dependent variable: luminance threshold for grating resolution determined by taking midpoint be-

- tween highest luminance at which an incorrect response was obtained and lowest luminance at which a correct response was obtained
- Observer's task: identify orientation of grating pattern
- 2 observers, 1 male and 1 female

Experimental Results

- For finer bar patterns (bar widths of 0.96-4.0 min arc), the dark adaptation curves are smooth decelerating functions. Threshold drops rapidly from a high level over the first several minutes and attains a final steady level in 7-10 min.
- For coarser gratings (bars of 12.0 and 23.8 min arc), the dark adaptation curves drop rapidly to an initial plateau and, after about 10 min, show a second, slower decrease that reaches a final level in ~30 min. These functions are similar to the dark adaptation function for a homogeneous (blank) test flash.
- The smaller the bar size, the higher the final luminance threshold level (the lower the sensitivity) reached after dark adaptation is complete.

Constraints

- These results may be valid only for bar patterns in the center of the visual field.
- Visual resolution is better when a greater number of bars of the same size are presented. Since all patterns had the same angular subtense, fine patterns contained more bars

Key References

*1. Brown, J. L., Graham, C. H., Leibowitz, H., & Ranken, H. B. (1953). Luminance thresholds for the resolution of visual detail during dark adaptation. *Journal of the Optical Society of America*, 43, 197-202.

Cross References

1.305 Factors affecting sensitivity to light;
1.406 Factors affecting dark adaptation;

1.407 Dark adaptation: effect of wavelength;

1.408 Dark adaptation: effect of target size;

Handbook of perception and human performance, Ch. 5, Sect. 4.2

Variability

- The uniform curves for small bar patterns and the upper branch of the dark-adaptation curves for larger bar patterns are assumed to reflect the sensitivity of the cone system (which shows high visual acuity); the lower, shallower branch of the functions for large bar patterns are assumed to reflect the activity of the rod system (which is less sensitive to fine detail than the cone system). Data are plotted for one observer; data for second observer were comparable.

Repeatability/Comparison with Other Studies

The data for coarse gratings indicating a two-branch function for dark adaptation are consistent with the results of studies manipulating other variables (such as test wavelengths or location in the field of view) which showed two phases of dark adaptation dominated by cone and rod activity (CRefs. 1.407, 1.408).

than coarse patterns; this may have led to a slight underestimation of thresholds for fine patterns relative to thresholds for coarse patterns.

- Many factors affect dark adaptation and should be considered in applying these results under different conditions (CRef. 1.406).

1.411 Dark Adaptation Following Exposure to Light of Varying Intensity

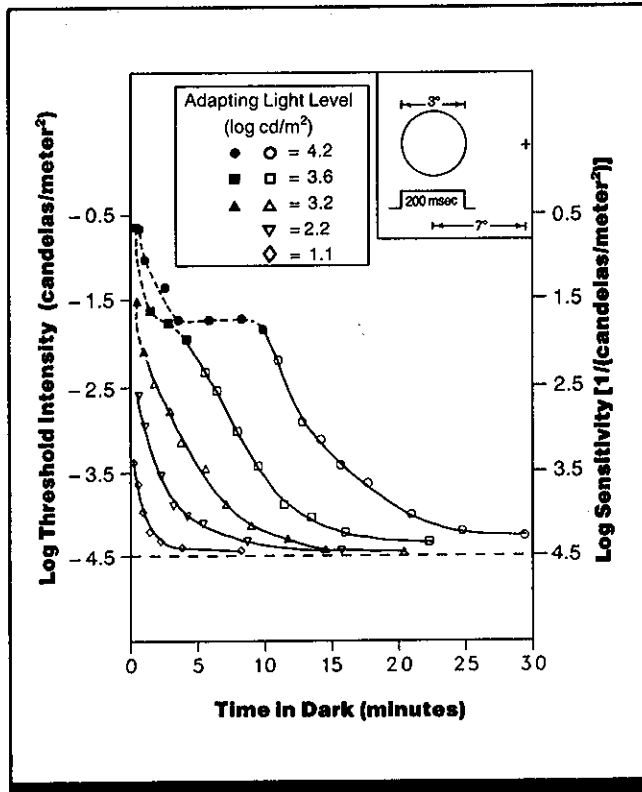

Figure 1. Visual sensitivity as a function of the time in the dark following exposure to various levels of adapting light. Filled symbols indicate that the test light appeared violet at threshold (indicating detection by cone system). Dashed curves are assumed to delineate the cone-mediated portion of the function; the solid curves, rod-mediated thresholds. (From *Handbook of perception and human performance*, based on data from Ref. 1)

Key Terms

Dark adaptation; peripheral vision; visual sensitivity

General Description

Absolute visual sensitivity (measured in the dark) decreases following exposure to light. The rate of recovery of sensitivity after the light is extinguished depends on the intensity of the preadapting light. After exposure to low illumination

levels, sensitivity recovers in ~5 min; for the high illumination levels, >30 min is required for complete recovery. The **cones** recover sensitivity more quickly than the **rods**, but the absolute sensitivity reached by the rods is much greater.

Applications

Visibility of dim targets is impaired by prior exposure to light, and the rate of improvement of target visibility is related to the intensity of prior light exposure. With prior exposure of sufficient intensity, visual sensitivity may not fully recover for >30 min.

Methods

Test Conditions

• Observer dark-adapted for 30 min, followed by 4-min fixation on preadapting light with intensity of 13-14,888 cd/m² (40-47,000 trolands); observations began immediately following offset of preadaptation light and contin-

ued until threshold reached relatively constant low level

- Test light flashed for 200 msec at each observation
- Light 3 deg in diameter and delivered 7-deg nasal to the fovea
- Light seen through violet filter (Corning filter 511) and viewed monocularly through artificial pupil 2 mm in diameter

Experimental Procedure

- Modified method of limits
- Independent variables: intensity of preadapting light, time in dark
- Dependent variable: intensity of light necessary for detection (threshold)

- Observer's task: report presence or absence of flash and describe color sensation associated with each threshold reading
- All data recorded in single session
- 1 observer

Experimental Results

- Visual sensitivity increases (threshold decreases) with time in the dark after the offset of a preadapting light.
- The recovery of visual sensitivity is slower, the higher the intensity of the preadapting light to which the observer is previously exposed.
- The discontinuity in the curves after preadaptation to the highest light intensities is assumed to reflect dark adaptation of the cones (upper branch of curve) and rods (lower branch). Only rod adaptation is seen at lower adapting intensities.

- The cone system recovers sensitivity more quickly than does the rod system; however, the rod system reaches much greater absolute sensitivity than the cone system.

Variability

Within-observer variability was not reported. Comparable data were obtained with a second observer who had pathologically fixed pupils.

Repeatability/Comparison with Other Studies

Data are consistent with other reports (e.g., Ref. 2).

Constraints

- The test stimulus was chosen to favor the rod system. It was short-wavelength light, to which rods are more sensitive than cones; it was positioned in the periphery of the retina, where rods are more numerous; and it was large and

long in duration, favoring the greater summation of the rod system.

- Many factors affect dark adaptation and should be considered in applying these results under different conditions (CRef. 1.406).

Key References

*1. Haig, C. (1941). The course of rod dark adaptation as influenced by the intensity and duration of preadaptation to light. *Journal of General Physiology*, 24, 735-751.

2. Hecht, S., Haig, C., & Chase, A. M. (1937). The influence of light adaptation on subsequent dark adaptation of the eye. *Journal of General Physiology*, 20, 831-850.

Cross References

1.406 Factors affecting dark adaptation;

1.412 Dark adaptation following exposure to light fields of varying size;

Handbook of perception and human performance, Ch. 5, Sect. 4.1

1.412 Dark Adaptation Following Exposure to Light Fields of Varying Size

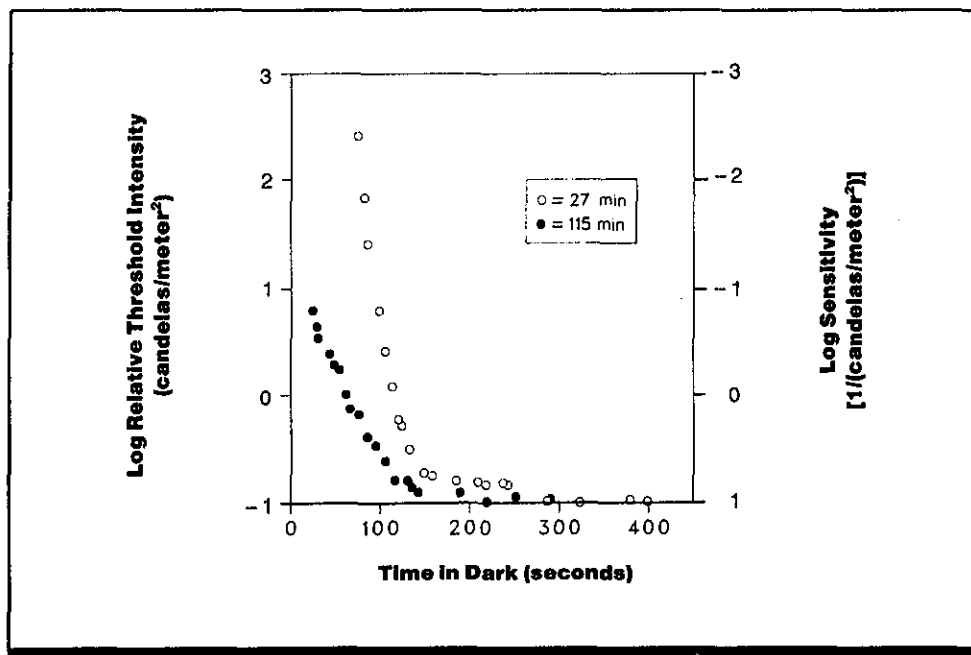

Figure 1. Detection threshold as a function of time in dark following exposure to a brief, intense preadapting light of 27 or 115 min arc diameter. (From Ref. 1)

Key Terms

Dark adaptation; field of view; flash bleaching; visual sensitivity

General Description

The time course of dark adaptation (increase in sensitivity in the dark) after exposure to a brief, intense preadapting light depends on the size of the preadapting light. Detection thresholds for cone vision are higher after small preadapting lights than after larger lights until dark adaptation is close to complete.

Methods

Test Conditions

- While observer looked at fixation light, preadapting bleaching light was presented 5 deg temporal to fovea; flash lasted 50 or 100 msec at intensity of $10^{6.7}$ trolands; flash diameter either 27 or 115 min arc of visual angle

- Beginning immediately after preadapting light was turned off, observer self-administered repeated exposures of 3-min-arc red test target; target presentations lasted 20 msec
- Target in center of area of pre-adapting light
- Monocular viewing

Experimental Procedure

- Independent variables: size of preadapting light, time in dark
- Dependent variable: intensity of target necessary for detection (threshold)
- Observer's task: signal when target first became visible; adjust target intensity to obtain threshold settings
- 2 observers

Experimental Results

- Following exposure to a 115-min-arc diameter preadapting light, detection threshold for a red light decreases (sensitivity increases) with an approximately exponential time course.
- Recovery of sensitivity following a smaller (27-min-arc) preadapting light is initially delayed; first measurable thresholds are at ~70 sec, followed by a rapid fall in threshold over the next ~40 sec.

- Thresholds for the small preadapting field approximate the large-field values at ~150 sec, when sensitivity is already within 0.2 log unit of the fully dark-adapted value for cone vision.

Repeatability/Comparison with Other Studies

Dark-adaptation curves for preadapting lights of different sizes follow a similar time course in peripheral (rod) vision (as opposed to cone vision, as presented here).

Constraints

- The results may be valid only for dark adaptation following very intense light flashes.
 - Many factors affect dark adaptation and should be considered in applying these results under different conditions (CRef. 1.406).
-

Key References

*1. Hayhoe, M. M. (1979). Lateral interactions in human cone dark adaptation. *Journal of Physiology*, 296, 125-140.

Cross References

1.101 Range of visible energy in the electromagnetic radiation spectrum;

1.406 Factors affecting dark adaptation;

Handbook of perception and human performance, Ch. 5, Sect. 4.3

1.413 Dark Adaptation Following Exposure to Light of Varying Duration

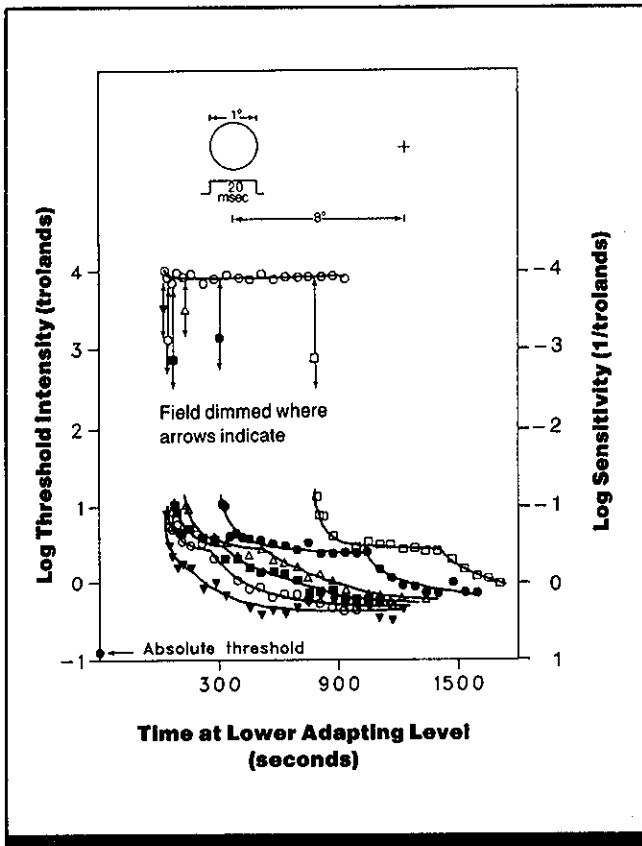

Figure 1. Dark adaptation in the parafovea following decrease in illumination. Observer was preadapted to bright light for the time indicated by the arrows, then background field was dimmed. Bottom curves show log increment in intensity necessary to detect a target against the dimmer background as a function of time since the drop in illumination; each symbol plots data for a different duration of pre-adaptation. Upper curve shows intensity increment thresholds for test light against the brighter, preadapting field. Target configuration was as shown in inset (cross = fixation point). Absolute threshold is the threshold for the test light in the dark. (From Ref. 1)

Key Terms

Brightness discrimination; dark adaptation; light increment threshold

General Description

Increasing the duration of exposure to a preadapting light prolongs the time course of recovery of visual sensitivity in the dark.

Applications

In situations requiring transition from briefly lit to dimly lit environments, adequate time should be allowed for dark adaptation to reach completion before an observer is required to perform tasks requiring visual detection.

Methods

Test Conditions

- Observer preadapted with 50,000-trolands visual field for varying durations up to ~800 sec, after which the field was dimmed to 5 trolands
- Target was round white spot subtending 1 deg of visual angle;

- parafoveal target presented 8 deg from fixation point
- 20-msec target flashes presented at 1-sec intervals with intensity increasing until observer reported its presence; target superimposed on dim (5 trolands) background
- Target viewed through small artificial pupil

Experimental Procedure

- Method of limits (ascending)
- Independent variables: durations of exposure to preadapting light, time in dark following offset of preadapting light
- Dependent variable: intensity difference threshold for detecting target against background

- Observer's task: indicate whether stimulus visible on each trial
- Each data point represents the mean of several threshold determinations
- Male and female observers, number not given; observers pre-tested for normal dark adaptation curves

Experimental Results

- When an observer is preadapted to a bright light and then the illumination level is suddenly decreased, sensitivity to light increases with time due to the drop in background illumination. That is, the luminance increment necessary for a test light to be just visible against the dimmer background (intensity difference threshold) decreases with time.
- The longer the exposure to the higher preadapting light, the longer the time required for threshold to reach its lowest, asymptotic value.

- The discontinuity in the dark-adaptation curves for the dim background is assumed to indicate the point of shift in dominance from the **cone** system to the **rod** system. The upper branch of each curve reflects the activity primarily of the cones; the lower branch, primarily of the rods.

Variability

No information on variability was given.

Repeatability/Comparison with Other Studies

Reference 2 reports a similar effect of preadaptation durations of up to 4 min.

Constraints

- Results are valid only for target presented parafoveally. The initial drop in threshold immediately after a dimming of illumination is much less for targets presented to the **fovea** (center of visual field).

- Many factors affect dark adaptation and should be considered in applying these results under different conditions (CRef. 1.406).

Key References

*1. Baker, H. D. (1955). Some direct comparisons between light and dark adaptation. *Journal of the Optical Society of America*, 45, 839-844.

2. Haig, C. (1941). The course of rod dark adaptation as influenced by the intensity and duration of preadaptation of light. *Journal of General Physiology*, 24, 735-751.

Cross References

1.406 Factors affecting dark adaptation;

Handbook of perception and human performance, Ch. 5, Sect. 4.3

Notes



Section 1.5 Sensitivity to Temporal Variations

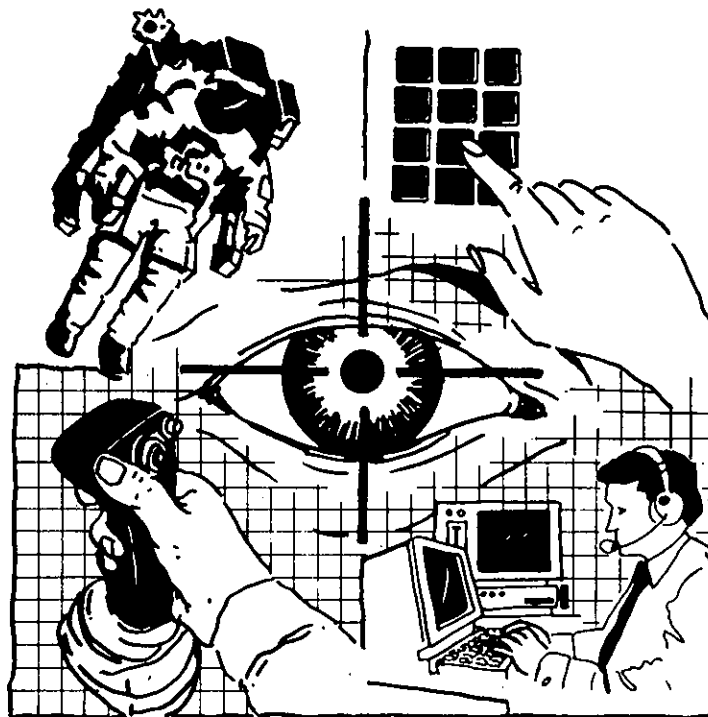

1.501 Factors Affecting Sensitivity to Flicker

Key Terms

Exposure duration; flicker detection; flicker frequency; light adaptation; size

General Description

The sensitivity of an observer to flicker generally is measured in one of two ways: (1) the rate of flicker of a target (such as a spot of light) is increased until the target appears steady. The flicker frequency at which the target first appears steady or fused is termed the *critical flicker frequency* (CFF); (2) the amplitude of luminance modulation; (flicker) of a given frequency is increased until the flicker can just be detected. Data collected using this method are often plotted as a *temporal contrast sensitivity function* showing the con-

trast sensitivity of the observer to flicker at a range of temporal frequencies (where contrast sensitivity is taken as the reciprocal of the modulation contrast threshold). In most visual studies, the luminance of the target is modulated sinusoidally over time to produce flicker. An observer's ability to detect flicker is affected by many variables. The table, which lists several of the more important factors known to influence sensitivity to or perception of flicker, indicates the nature of their effects, and cites entries or sources providing further information.

Variable	Spatial Target	Effect on Sensitivity to Flicker	References
Flicker frequency	Disks of varying sizes; sine-wave gratings	Sensitivity is greatest to flicker at ~5-20 Hz and decreases at higher frequencies; sensitivity also decreases at frequencies <5 Hz for disk targets, but not for grating patterns of moderate or high spatial frequency	CRefs. 1.503, 1.505, 1.506, 1.508
Flicker waveform	2-deg disk, variety of temporal waveforms	No differences in sensitivity above 10 Hz among waveforms; some differences below 10 Hz	Refs. 1, 2
Adaptation	1-deg square, no surround	CFF is highest for light-adapted eye; for foveal target, CFF decreases during dark adaptation ; for peripheral target with low luminance, CFF first decreases then increases during dark adaptation	CRef. 1.504
Background intensity (average luminance)	Disks, sine-wave gratings	The smallest detectable change in intensity increases with increasing background intensity, less rapidly for high temporal frequencies than for low temporal frequencies	Refs. 1, 2, 5, 6 CRefs. 1.502, 1.503, 1.505
Type of surround	Disks of varying sizes	Modulation sensitivity is greater for a target with a light surround than for a target with no surround	CRef. 1.506
Duration	Sine-wave gratings	Sensitivity increases as $\frac{1}{4}$ power of target duration	Ref. 9
Location in visual field	Sine-wave gratings	Greater for foveal than for peripheral targets	Refs. 6, 8 CRef. 1.504
Spatial frequency	Sine-wave gratings	For low temporal frequencies, highest at middle spatial frequencies ; for high temporal frequencies, highest at low spatial frequencies and declining for higher spatial frequencies	CRef. 1.508
Target size	Disks, sine-wave gratings	CFF increases with increasing size; sensitivity to low temporal frequencies decreases with increasing size	Ref. 4 CRefs. 1.506, 1.507
Type of target	Uniform field, sine-wave gratings	At low flicker frequencies, sensitivity is greater for flickering bar patterns than for flickering uniform fields	CRef. 1.505
Threshold criteria	Sine-wave gratings	Threshold for seeing pattern lower than threshold for seeing flicker when viewing pattern flickering at low temporal frequencies; opposite is the case for high temporal frequencies	Refs. 3, 7

Constraints

• Interactions occur among the various factors affecting sensitivity to flicker. Important interactions are mentioned in the table. Sources for others can be found by examination of the table. For example, Ref. 2 is listed for the variables of background intensity and waveform. The interaction of the two, although not referred to in the table, can be found in this source.

• The targets used in the studies summarized here were all presented for at least several flicker cycles. Effects may be somewhat different for transient (pulsed or flashed) targets (CRef. 1.511).

• Sensitivity to flicker is also influenced by many factors not discussed here, including the onset/offset abruptness of the target, target duty cycle, monocular versus binocular viewing, and subject variables such as age, sex, fatigue, temperature, body position, practice, attention, drug use, and anoxia (see Ref. 2).

Key References

1. Brown, J. L. (1965). Flicker and intermittent stimulation. In C. H. Graham (Ed.), *Vision and visual perception*. New York: Wiley.

2. de Lange, H. (1954). Relationship between critical flicker frequency and a set of low frequency characteristics of the eye. *Journal of the Optical Society of America*, 44, 380-389.

3. de Lange, H. (1958). Research into the dynamic nature of the human fovea-cortex systems with

intermittent and modulated light. I. Attenuation characteristics with white and colored light. *Journal of the Optical Society of America*, 48, 777-784.

4. Keesey, U. T. (1972). Flicker and pattern detection: A comparison of thresholds. *Journal of the Optical Society of America*, 62, 446-448.

5. Kelly, D. H. (1959). Effects of sharp edges in a flickering field. *Journal of the Optical Society of America*, 49, 730-732.

6. Kelly, D. H. (1972). Adaptation effects on spatio-temporal sine-wave thresholds. *Vision Research*, 12, 89-101.

7. Koenderink, J. J., Bouman, M. A., Bueno de Mesquita, A. E. & Slappendel, S. (1978). Perimetry of contrast detection thresholds of moving spatial sine wave patterns. I. The near peripheral visual field (eccentricity 0°-8°). *Journal of the Optical Society of America*, 68, 845-849.

8. Kulikowski, J. J., & Tolhurst, D. J. (1973). Psychophysical evidence for sustained and transient mechanisms in human vision. *Journal of Physiology*, 232, 149-163.

9. Virsu, V., Rovamo, J., Laurinen, P., & Nasanen, R. (1982). Temporal contrast sensitivity and cortical magnification. *Vision Research*, 22, 1211-1217.

10. Watson, A. B. (1979). Probability summation over time. *Vision Research*, 19, 515-522.

Cross References

1.502 Flicker sensitivity: effect of background luminance;

1.503 Flicker sensitivity: effect of flicker frequency and luminance level;

1.504 Flicker sensitivity: effect of dark adaptation for targets at different visual field locations;

1.505 Flicker sensitivity: effect of type of target and luminance level;

1.506 Flicker sensitivity: effect of target size and surround;

1.507 Flicker sensitivity: effect of target size;

1.508 Flicker sensitivity: effect of target spatial frequency;

1.511 Factors affecting sensitivity to brief (pulsed) targets

1.502 Flicker Sensitivity: Effect of Background Luminance

Key Terms

De Vries-Rose Law; flicker detection; flicker frequency; luminance; temporal modulation; Weber's Law

General Description

The detectability of a flickering target depends on the luminance of its background. In general, a flickering target will be less visible the higher the background luminance level. The smallest detectable change in luminance (increment or decrement) from the background luminance is termed the threshold intensity, ΔI ; the contrast threshold is the ratio of the threshold intensity change to the background intensity, I , or $\Delta I/I$.

For very dim backgrounds, the visibility of a flickering target is limited by the intrinsic variability (noise) of the visual system, and the threshold intensity remains at absolute threshold (threshold relative to dark background). For somewhat more intense backgrounds, threshold is limited by photon noise (quantum fluctuations) and threshold intensity increases with the square root of background luminance, $\Delta I = K\sqrt{I}$, where K is a constant (de Vries-Rose Law). At still higher background levels, neural adaptation further reduces visual sensitivity, and threshold intensity increases in direct proportion to background luminance, $\Delta I = KI$ (Weber's Law). The constant of proportionality, $K = \Delta I/I$, is known as the Weber constant. The background levels at which these various relationships occur depend on the temporal and spatial properties of the target.

Figure 1 shows data illustrating these three regimes. The effect of background intensity is more pronounced at the lower temporal frequency (1.5 Hz); at this frequency, the data conform to the regime of Weber's Law at a lower background intensity than do data for higher frequency flicker (20 Hz).

Applications

The relationship described here can be used to estimate the visibility of flickering light or dark targets on an unchanging background (provided targets are small and viewing is foveal). In particular, if the background is within the Weber's Law region, a target is visible when its contrast is greater than the Weber fraction ($\sim 2\%$, as shown in Fig. 1a). The 1.5-Hz data of Fig. 1 may also be applied to nonflickering targets.

Methods

Test Conditions

- 2-deg-diameter white flickering field; steady 60-deg diameter white surround of equal luminance; luminance modulated sinusoidally at temporal frequency of 1.5 or 20 Hz

- Time-averaged luminance ranged from 0.016-1624 cd/m²
- Monocular viewing through 2.8-mm diameter artificial pupil; observer fixated center of target (foveal viewing prevents target detection by rods)

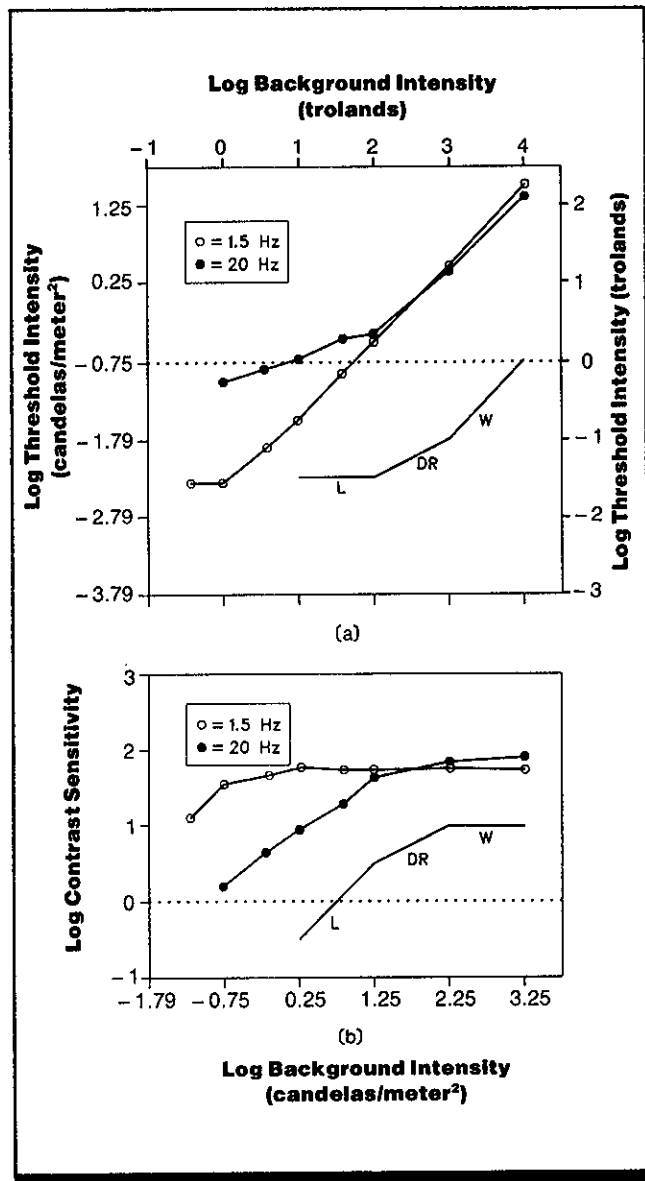

Figure 1. Temporal sensitivity as a function of background luminance for slowly flickering (open circles) or rapidly flickering (filled circles) targets. Target is a flickering 2-deg disk surrounded by large steady background with luminance equal to the time-average of the target. Data are plotted as (a) threshold intensity (smallest detectable change in intensity above or below background level) and (b) contrast threshold (ratio of threshold intensity to background level). Insets show expected slopes corresponding to the three regimes described in the text: at lowest background levels, threshold is independent of background luminance (linear regime, L); at intermediate levels, threshold increases with the square root of background luminance (de Vries-Rose Law; DR); at high background levels, threshold increases in direct proportion to background luminance (Weber's Law; W). (From *Handbook of perception and human performance*, based on data from Ref. 1)

Experimental Procedure

- Method of adjustment
- Independent variables: temporal frequency, time-averaged luminance level
- Dependent variable: intensity (modulation) threshold (smallest detectable luminance change)

- Observer's task: adjust amplitude of target flicker until flicker just visible
- 2 observers with extensive practice

Experimental Results

- Threshold (modulation) intensity (ΔI) remains constant on backgrounds from dark to ~ 0.15 cd/m².
- For dim background levels, threshold intensity increases in direct proportion to the square root of background luminance (de Vries-Rose Law).

- For backgrounds above ~ 2 -10 cd/m², threshold intensity increases in direct proportion to background luminance (Weber's Law).
- The Weber constant for flickering target disks is ~ 1 -2% (Fig. 1b).
- The background luminance at which Weber's Law applies is lower for slowly flickering targets than for rapidly flickering ones.

Constraints

- Flicker sensitivity may differ if fields contain spatial structure (CRef. 1.505).
- Target size affects the background levels at which de Vries-Rose and Weber's Law relationships hold.
- Results will be different with large targets or peripheral viewing that allows detection by the rods.

- Weber's Law may not apply at very high background levels; photopigment bleaching or neural overloading may reduce sensitivity below that predicted by Weber's Law.
- Many factors (such as luminance level, exposure time, and target location in the visual field) influence sensitivity to flicker and must be considered in applying these results under different conditions (CRef. 1.501).

Key References

*1. de Lange, H. (1958). Research into the dynamic nature of the human fovea-cortex systems with intermittent and modulated light. *Journal of the Optical Society of America*, 44, 777-789.

2. de Vries, H. L. (1943). The quantum character of light and its bearing upon threshold of vision, the differential sensitivity and visual acuity of the eye. *Physica*, 10, 553-564.

3. Rose, A. (1942). The relative sensitivity of television pickup tubes, photographic film, and the human eye. *Proceedings of the Institute of Radio Engineers*, 30, 293-300.

Cross References

1.501 Factors affecting sensitivity to flicker;

1.503 Flicker sensitivity: effect of flicker frequency and luminance level;

1.504 Flicker sensitivity: effect of dark adaptation for targets at different visual field locations;

1.505 Flicker sensitivity: effect of type of target and luminance level;

Handbook of perception and human performance, Ch. 6, Sect. 11.3

1.503 Flicker Sensitivity: Effect of Flicker Frequency and Luminance Level

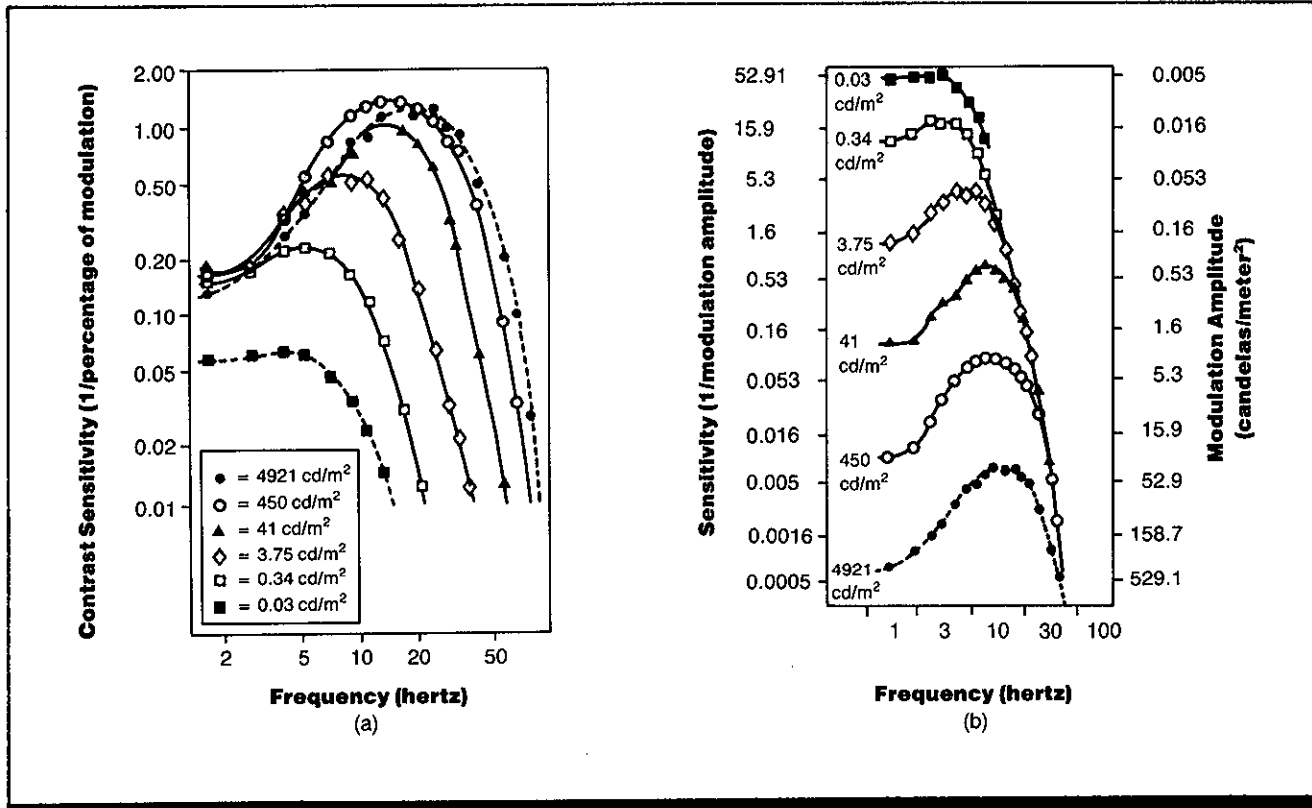

Figure 1. Sensitivity to flicker as a function of luminance level and temporal modulation rate. (a) Data plotted in terms of contrast sensitivity, or the reciprocal of modulation contrast in percent; that is, $1/[(\Delta L/L) \times 100]$ where L is average luminance (one-half maximum luminance + minimum luminance) and ΔL is the smallest detectable modulation in luminance (one-half maximum luminance - minimum luminance). (b) The same data plotted in terms of absolute sensitivity, or the reciprocal of modulation threshold; that is, $1/\Delta L$; modulation threshold (in cd/m^2) is given on the right. (From Ref. 2)

Key Terms

Flicker detection; flicker frequency; light adaptation; luminance; modulation transfer function; temporal contrast sensitivity; temporal modulation

General Description

Sensitivity to flicker may be measured by reducing the amplitude of the luminance modulation of a target flickering at a fixed frequency until the flicker is no longer perceived. This yields the temporal contrast (or modulation) threshold, which has temporal contrast sensitivity as its reciprocal. Contrast sensitivity for slow flicker rates is approximately

constant, regardless of the average luminance of the target for luminances $\geq 0.34 \text{ cd/m}^2$. That is, $\Delta L/L = a$ constant (Weber's law), where L is the time-averaged luminance of the target and ΔL is the smallest change in target luminance above or below L that can be detected. Contrast sensitivity to intermediate and high flicker rates changes with average luminance.

Applications

In many applications it is necessary to modify a target to prevent perceptible flicker. To selectively reduce the visibility of slow flicker, modulation contrast ($\Delta L/L$) may be reduced by adding a steady veiling light to the target; this does not affect the visibility of rapid flicker. Conversely, to selectively reduce the visibility of rapid flicker, modulation

depth (ΔL) may be reduced by filtering the light from the target, or by lowering the intensity of the flickering source; this procedure does not affect the visibility of slow flicker. To reduce the visibility of intermediate flicker, both modulation contrast and modulation depth may be reduced without changing average luminance (e.g., by lowering the contrast of a video display).

Methods**Test Conditions**

- Target was white circle, 68 deg of visual angle in diameter with blurred edges; target flickered with sinusoidal waveform (frequency range 1.6-75 Hz)

- Monocular viewing through artificial pupil of 1.55 mm
- Average luminance varied from 0.03-4921 cd/m² (0.06-9300 tro-lands) with neutral density filters

Experimental Procedure

- Method of adjustment

- Independent variables: temporal frequency, average luminance
- Dependent variable: modulation threshold ΔL (smallest detectable luminance change)
- Four threshold settings obtained for each data point
- One observer with extensive practice

Experimental Results

- Modulation contrast remains approximately constant (~7%) for low frequencies (1.6-4 Hz) at luminance levels between 0.34 and 4921 cd/m².
- For targets of fixed average luminance, contrast sensitivity is relatively higher for intermediate frequencies (8-20 Hz) and falls off for lower and higher frequencies. The exception is the target with a very low average luminance of 0.03 cd/m², which showed no decline in sensitivity at low flicker frequencies.
- Except at low temporal frequencies, contrast sensitivity declines as average luminance is reduced (Fig. 1a);

however, absolute sensitivity ($1/\Delta L$, unweighted by average luminance) increases as luminance level declines (Fig. 1b).

- As average luminance increases, peak sensitivity shifts toward higher flicker frequencies.

Variability

Variability of individual observer's data not reported. Results for observer shown in Fig. 1 closely resemble mean responses of 8 normal observers at 450 cd/m².

Repeatability/Comparison with Other Studies

Curves have steeper low-frequency slopes than those obtained with smaller targets (Ref. 1).

Constraints

- Contrast sensitivity may differ from that shown in Fig. 1 if target configuration is different [e.g., if target area differs (CRef. 1.507) or target contains an edge or pattern near the point of fixation (CRef. 1.506)].

- Results may differ for targets viewed eccentrically or under low-luminance (scotopic) conditions.
- Many factors, such as target shape, wavelength, age, degree of practice, etc., may affect flicker perception and should be considered in applying these data under different conditions (CRef. 1.501).

Key References

1. de Lange, H. (1958). Research into the dynamic nature of the human fovea-cortex systems with intermittent and modulated light. *Journal of the Optical Society of America*, 44, 777-789.

*2. Kelly, D. H. (1961). Visual response to time-dependent stimuli. I. Amplitude sensitivity measurements. *Journal of the Optical Society of America*, 51, 422-429.

Cross References

1.501 Factors affecting sensitivity to flicker;

1.504 Flicker sensitivity: effect of dark adaptation for targets at different visual field locations;

1.505 Flicker sensitivity: effect of type of target and luminance level;

1.506 Flicker sensitivity: effect of target size and surround;

1.507 Flicker sensitivity: effect of target size

1.504 Flicker Sensitivity: Effect of Dark Adaptation for Targets at Different Visual Field Locations

Key Terms

Critical flicker frequency; dark adaptation; flicker detection; retinal location; temporal modulation; visual field location

General Description

If a light is turned on and off rapidly enough, the flicker cannot be perceived, i.e., the light appears steady or fused. The alternation rate at which fusion occurs is the critical flicker frequency (CFF). The CFF depends on the time-averaged luminance of the flickering target, its location in the visual field, and observer's state of adaptation. Highest CFF values are found for a light-adapted observer looking directly at a target of high luminance.

For targets of moderate to high luminance, flicker sensitivity, as measured by the CFF, is best when the observer is light-adapted and worst when dark-adapted.

In general, CFF is higher for centrally fixated (foveal) targets than for targets further from fixation. For centrally fixated targets, CFF decreases monotonically during dark adaptation (Fig. 1), and the decrease is more rapid for higher test-patch illuminations. For nonfoveal targets, CFF decreases monotonically with time in the dark when target luminance is relatively high; the decrease is more rapid and has a longer duration than for centrally fixated targets (other than for targets 90 deg from fixation). However, the shape of the function for peripheral target changes with illumination.

Applications

When an observer at a video display glances briefly at a scene of high luminance (e.g., out a window or at a bright surface), the display may flicker noticeably until the observer re-adapts to its lower luminance.

A street light that appears steady at night may appear to flicker during daylight.

Figure 1. Critical flicker frequency during dark adaptation. Solid curves represent data from one observer; final point represents data from four observers. CFF is shown as a function of time in the dark for targets at various angular distances from fixation, as indicated on curves. Observers light-adapted at 77.5 cd/m^2 for 15 min before dark adaptation. Time-averaged luminance of test target was (a) 23.3 cd/m^2 and (b) 0.86 cd/m^2 . (From Ref. 2)

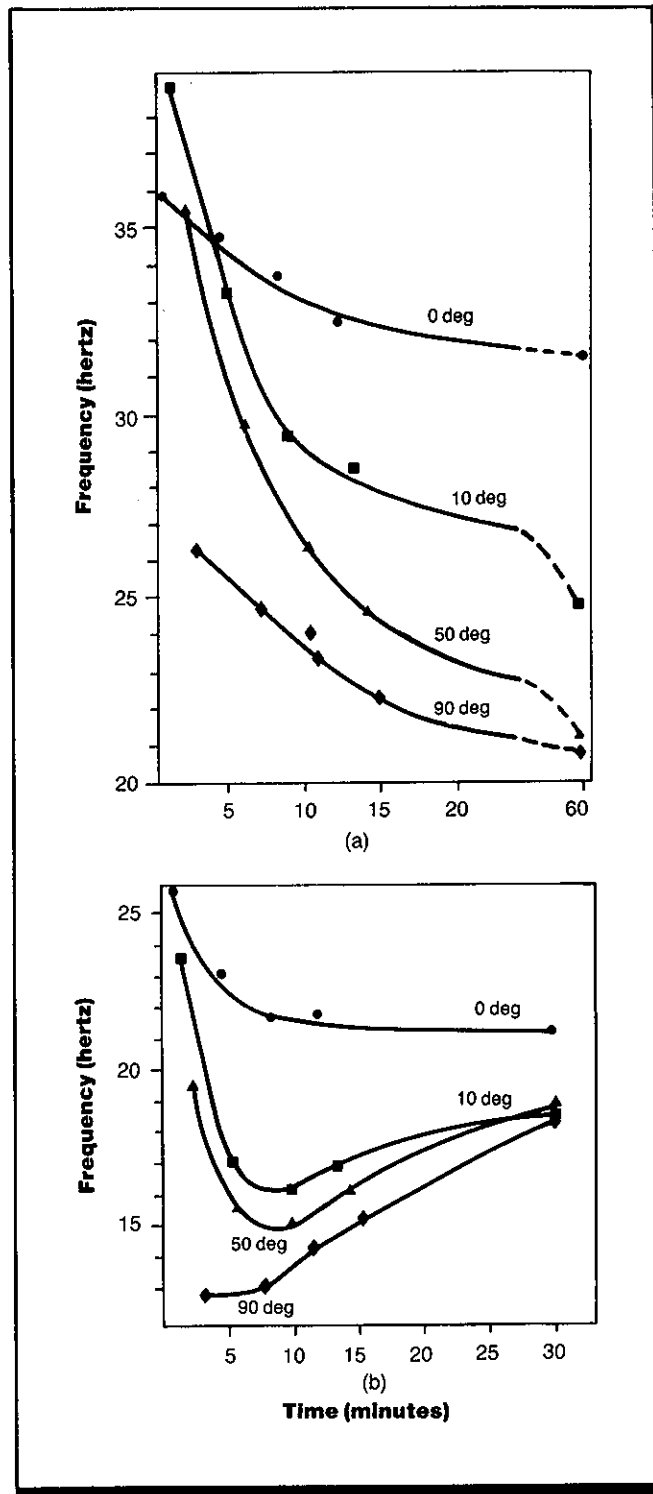

Methods

Test Conditions

- Observer pre-adapted in dark chamber that was then evenly illuminated to 77.5 cd/m² (24.35 mL) for 15 min; chamber then darkened from dark-adaptation data collection

- Target was light source chopped by rotating sector-disk to produce square-wave luminance alternations; square target, 1 deg on a side; target intensity 2.33, 0.86, 0.07, or 0.00096 cd/m²; viewing distance = 152 cm
- Target centered on point of fixation or displaced 10, 50, or 90 deg from fixation point

- In eccentric fixation conditions, test viewed intermittently for 1.2-sec periods to prevent fading of field
- Monocular viewing, but both eyes were equally light-adapted; natural pupil

- Independent variables: distance of target from fixation (retinal eccentricity), time in the dark, average luminance of target
- Dependent variable: minimum flicker frequency producing perceived fusion of target (CFF)
- Observer's task: adjust flicker frequency until target does not flicker (fuses)
- 6 observers; figure shows results from 1 observer

Experimental Procedure

- Method of adjustment

Experimental Results

- In general, CFF decreases as target distance from the fixation point increases.
- For all viewing conditions, CFF increases with target luminance.
- For central viewing (targets 0 deg from fixation), CFF falls as time in the dark increases.
- For peripheral targets (≥ 10 deg from fixation), CFF also falls monotonically with time in the dark provided the targets are relatively bright. When the targets are dim, however, CFF may fall for 5-10 min and then rise, or may rise through the entire period of dark adaptation. The rises occur under conditions where rods are detecting the flicker.

- The reversal of sensitivity shown in Fig. 1b is believed due to activity of rod photoreceptors, which come into play under low light levels.

Variability

CFF settings are said to be repeated to within 1%. The figure illustrates the results for 1 observer; all others produced similar results, except 1 who had night-blindness (lack of rod sensitivity).

Repeatability/Comparison with Other Studies

Results for centrally fixated targets confirmed by Ref. 3 for targets of just-detectable luminance.

Constraints

- Effects of target location in the visual field may be different for larger targets.
- Target luminance may have prevented observer's eye from becoming completely dark-adapted.

- Many factors influence sensitivity to flicker and must be considered in applying these results under different conditions (CRef. 1.501).

Key References

1. Graham, C. H. (Ed.) (1965). *Vision and visual perception*. New York: Wiley.

*2. Lythgoe, R. J., & Tansley, K. (1929). The relation of the critical frequency of flicker to the adaptation of the eye. *Proceedings of the Royal Society (London)*, B105, 60-92.

3. White, K. D., & Baker, H. D. (1976). Foveal CFF during the course of dark adaptation. *Journal of the Optical Society of America*, 66, 70-72.

Cross References

1.501 Factors affecting sensitivity to flicker;

1.502 Flicker sensitivity: effect of background luminance;

1.503 Flicker sensitivity: effect of flicker frequency and luminance level

1.505 Flicker Sensitivity: Effect of Type of Target and Luminance Level

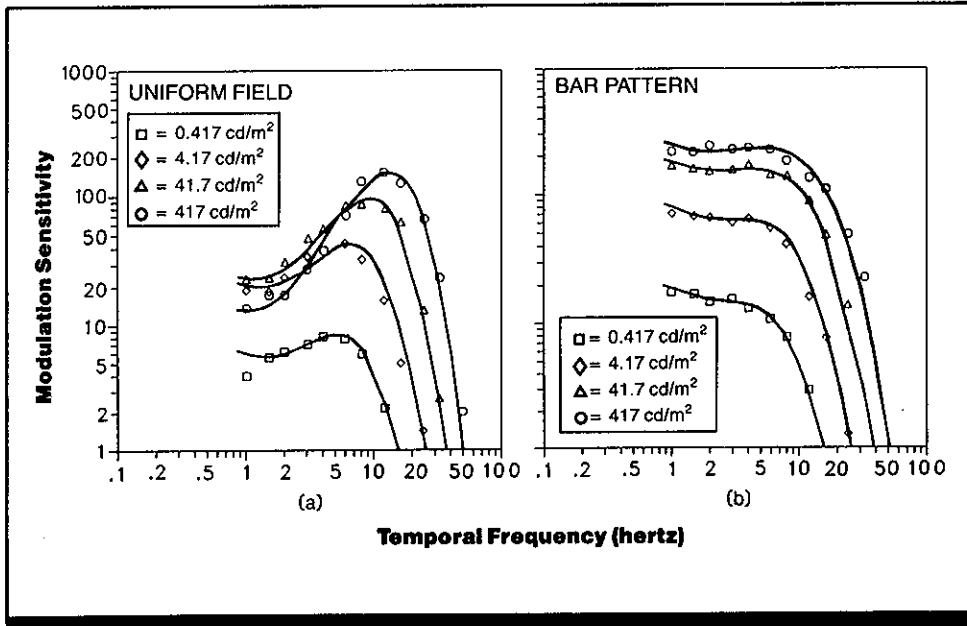

Figure 1. Temporal contrast (modulation) sensitivity (the reciprocal of modulation threshold) as a function of temporal frequency for a spatially uniform field and a 3 cycles/deg bar pattern flickering in counterphase mode. Each panel shows results for four levels of mean luminance, as indicated in the legends. Solid functions are theoretical. (From Ref. 2)

Key Terms

Flicker detection; flicker frequency; light adaptation; luminance; modulation transfer function; temporal contrast sensitivity; temporal modulation

General Description

Interactions among flicker frequency, target **spatial frequency**, and background illumination influence the depth of luminance modulation necessary to detect flicker in a target. The temporal **contrast-sensitivity** function (reciprocal of modulation contrast threshold as a function of temporal frequency) for a large uniform field (Fig. 1a) has a band-pass shape with a shallow fall-off at low temporal frequencies, a peak between 8 and 15 Hz, and a steep high-frequency fall-off. The function retains this shape as average field luminance is reduced, although the low-frequency fall-off becomes shallower at very dim luminances.

Applications

Slow changes in luminance are more easily detected in fields with spatial structure than in uniform fields. For example, low-frequency flicker in a video display may be

This attenuation at low temporal frequencies does not occur for flickering bar patterns; rather, the temporal contrast sensitivity function takes on a low-pass shape with no attenuation up to ~10 Hz. As background luminance is reduced, this curve shifts downward and to the left, but does not change shape (Fig. 1b).

Thus sensitivity to low-frequency flicker is enhanced in a field containing a bar pattern relative to a spatially uniform field of the same mean luminance, but this enhancement occurs only for flicker rates <10-15 Hz. High-frequency flicker sensitivity is not affected by the presence of a bar pattern. The enhancement is greatest for bar patterns of ~3 cycles/deg, and at high-luminance levels.

more noticeable in the presence of raster lines, a reticle, or dirt smudges, than when the display is spatially uniform. However, spatial structure does not affect sensitivity to temporal frequencies >15-20 Hz.

Methods

Test Conditions

- Uniform field with 7-deg diameter; dark surround; presentation via CRT
- 3 cycle/deg sine-wave gratings produced electronically; counter-

phase mode (amplitude of grating alternates above and below mean luminance level at specified flicker rate, with bright and dark bars flickering in opposite phase)

- Monocular viewing with fixation on center of screen; viewing distance 50 cm; 2.3-mm diameter artificial pupil

- Average screen luminance from 0.417-417 cd/m² (1.67-1670 Td); luminance modulation (flicker) at 1-50 Hz

- Dependent variable: temporal contrast threshold (luminance modulation amplitude necessary to detect flicker)
- Observer's task: adjust contrast of flickering grating until just visible
- 1 observer with extensive practice

Experimental Procedure

- Method of adjustment
- Independent variables: average luminance level, patterned versus uniform field

Experimental Results

- Sensitivity to flicker of a uniform field has a band-pass shape, with its peak at intermediate temporal frequencies. A reduction in average luminance level shifts the curve downward and shifts the peak to a lower frequency; it also causes shallower low-frequency attenuation.
- Sensitivity to flicker of a 3 cycles/deg counterphase bar pattern has a low-pass shape with no low-frequency attenuation. A reduction in average luminance level shifts the curve downward and to the left.
- For fields of equal mean luminance and area, low-frequency flicker (10-15 Hz or less) is more detectable when a bar pattern is present than when the flickering field is spatially uniform.
- Sensitivity for 1-Hz flicker is about 15 times greater for a 3-cycles/deg counterphase bar pattern than for a uniform field of the same high mean luminance.

- Similar, but smaller, flicker enhancement effects can be obtained with square-wave bar patterns of various spatial frequencies, or by reducing the size of the uniform field or introducing a counterphase flickering edge.

Variability

No information on variability was given. Results confirmed with second subject.

Repeatability/Comparison with Other Studies

Results of Ref. 2 using a 7-deg field agree with an earlier study (Ref. 1) that used a much wider field (65 deg). Greatest sensitivity has been found at a slightly higher temporal frequency (~20 Hz) for some luminance levels for large (68-deg) fields (CRef. 1.503). Shallower low-frequency attenuation is obtained using a smaller (2 deg) uniform field (Ref. 3).

Constraints

- Enhancement of low-frequency flicker by bar patterns may not be as great as illustrated here if the spatial frequency of the bar pattern is not optimal. The effect is obtained for sinusoidal bar patterns of 2-3 cycles/deg.
- If the bar pattern is flickered in an on-off rather than counterphase manner, flicker sensitivity is reduced relative to that shown here.

- Individual differences may shift curves vertically, but ratios of sensitivities to uniform and structured fields will be similar.
- Many factors (such as luminance level, exposure time, and target location in the visual field) influence sensitivity to flicker and must be considered in applying these results under different conditions (CRef. 1.501).

Key References

1. Kelly, D. H. (1969). Flickering patterns and lateral inhibition. *Journal of the Optical Society of America*, 59, 1361-70.

*2. Kelly, D. H. (1971). Theory of flicker and transient responses, II. Counterphase gratings. *Journal of the Optical Society of America*, 61, 632-40.

3. Kelly, D. H. (1972). Adaptation effects on spatio-temporal sine-wave thresholds. *Vision Research*, 12, 89-101.

4. de Lange, H. (1958). Research into the dynamic nature of the human fovea-cortex systems with intermittent and modulated light. *Journal of the Optical Society of America*, 48, 777-84.

Cross References

1.501 Factors affecting sensitivity to flicker;

1.502 Flicker sensitivity: effect of background luminance;

1.503 Flicker sensitivity: effect of flicker frequency and luminance level;

1.506 Flicker sensitivity: effect of target size and surround;

1.507 Flicker sensitivity: effect of target size;

1.508 Flicker sensitivity: effect of target spatial frequency;

Handbook of perception and human performance, Ch. 6, Sect. 11.7

1.506 Flicker Sensitivity: Effect of Target Size and Surround

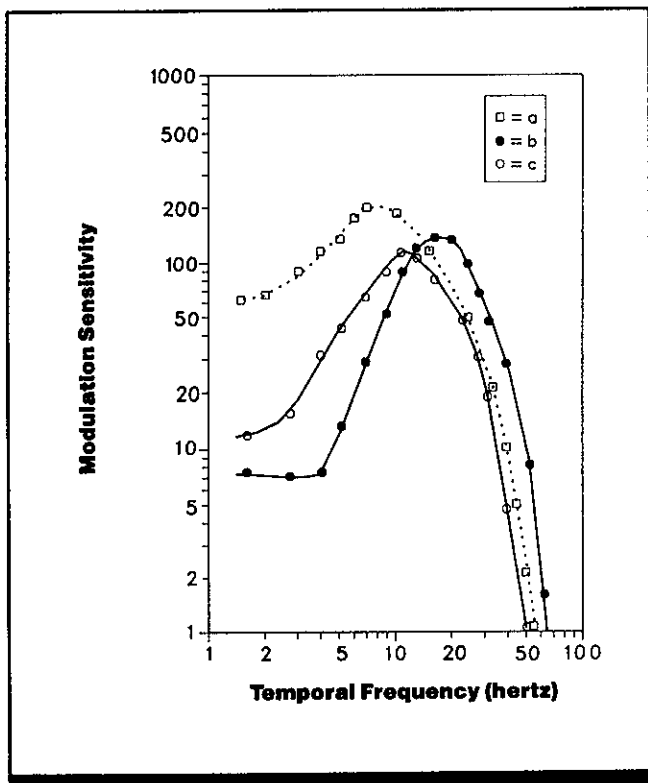

Figure 1. Modulation sensitivity (the reciprocal of modulation threshold) to sinusoidal flicker as a function of temporal frequency for three spatial target configurations. (a) Open squares: 2-deg target with equilluminous steady surround (Ref. 3); (b) filled circles: 4-deg target with dark surround (Ref. 1); (c) open circles: 68-deg field with blurred edges (Ref. 1). (Each curve is for 1 observer.) (From Ref. 1)

Key Terms

Flicker detection; modulation transfer function; size; surround configuration; temporal contrast sensitivity; temporal modulation

General Description

Flicker sensitivity is less for low and high rates of temporal modulation than for mid-range flicker frequencies. At high temporal frequencies, flicker sensitivity is influenced little by the target size and surround. However, at low frequen-

cies flicker sensitivity is greater for small targets viewed against a surround of equal average luminance than for flickering edgeless fields or for targets viewed against a dark surround.

Methods

Test Conditions

- Light surround (Ref. 3): 2-deg diameter white flickering field; steady 60-deg diameter white surround of equal luminance; monocular viewing; sinusoidal luminance modulation (1.5-70 Hz)

- Edgeless field (Ref. 1): 68-deg diameter white flickering field; time-averaged luminance ~100 cd/m²; outer edges blurred to black over 18 deg; monocular viewing; sinusoidal luminance modulation (1.6-75 Hz)
- Dark surround (Ref. 1): 4-deg diameter white flickering field; dark surround; time-averaged lumi-

nance ~100 cd/m²; monocular viewing; sinusoidal luminance modulation (1.6-75 Hz)

Experimental Procedure

- Method of adjustment
- Independent variables: temporal frequency of luminance modulation, spatial configuration of targets

- Dependent variable: modulation threshold (smallest detectable luminance change)
- Observer's task: adjust luminance modulation of target until flicker just visible
- 2 observers with extensive practice for light surround; 8 observers with extensive practice for dark surround and edgeless field

Experimental Results

- Sensitivity to flicker is relatively high for intermediate temporal frequencies (8-20 Hz) and decreases for lower and higher frequencies.
- At low flicker frequencies, sensitivity is greater for a small (2-deg) target against a bright background than for a large target with blurred edges.
- Flicker sensitivity for a 2-deg spot against a bright background is very much greater than sensitivity for a 4-deg spot against a dark background. It is not clear whether the

greatly reduced sensitivity for the latter target is due to its increased size or the absence of a surround.

- Flicker sensitivity is close to the same for all three target configurations at high temporal frequencies.

Variability

- No information on variability was given. In the edgeless field and dark-surround cases, variability was reported to be much smaller than effects of spatial configuration (Ref. 2).

Constraints

- Enhanced sensitivity at the lowest temporal frequencies in dark surround case may not occur at lower luminance levels (Ref. 2).

- Enhanced sensitivity at the lowest temporal frequencies may be reduced if the edge between flickering field and surround is not sharply focussed (Ref. 1).

- Many factors, such as target luminance and exposure time, affect sensitivity to flicker and must be considered in applying these results (CRef. 1.501).

Key References

*1. Kelly, D. H. (1959). Effects of sharp edges in a flickering field. *Journal of the Optical Society of America*, 49, 730-732.

2. Kelly, D. H. (1969). Flickering patterns and lateral inhibition. *Journal of the Optical Society of America*, 59, 1361-1370.

*3. de Lange, H. (1958). Research into the dynamic nature of the human fovea cortex systems with intermittent and modulated light. I. Attenuation characteristics with

white and colored lights. *Journal of the Optical Society of America*, 48, 777-789.

Cross References

1.501 Factors affecting sensitivity to flicker;

1.502 Flicker sensitivity: effect of background luminance;

1.503 Flicker sensitivity: effect of flicker frequency and luminance level;

1.507 Flicker sensitivity: effect of target size;

Handbook of perception and human performance, Ch 6, Sect. 9.2

1.507 Flicker Sensitivity: Effect of Target Size

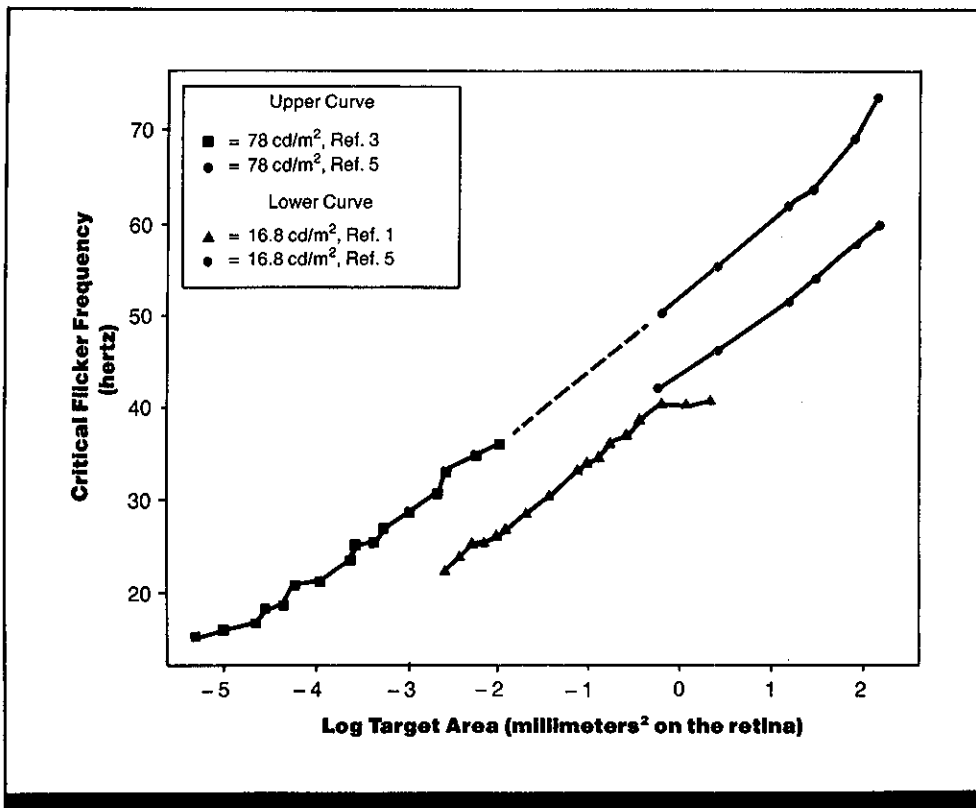

Figure 1. Critical flicker frequency for circular targets as a function of log target area. Average target luminance was 78.0 cd/m² (upper curve) and 16.8 cd/m² (lower curve). Circles are data from the study described here; squares and triangles show comparison data from two other studies. (From Ref. 4)

Key Terms

Critical flicker frequency; flicker detection; size; temporal modulation

General Description

An observer's sensitivity to temporal changes in target luminance can be measured by increasing the flicker rate of the target until it appears steady or "fused." The flicker rate at which fusion occurs is called the critical flicker frequency (CFF). Temporal sensitivity is higher when the CFF occurs at a higher flicker rate. For uniform targets of fixed average

luminance, CFF increases approximately linearly with the logarithm of target area, i.e., $CFF = b \log A + c$, where A is target area and b and c are constants. This relationship, known as the Granit-Harper Law (Ref. 2), applies over a wide range of target sizes. For circular targets, CFF increases with target area up to 50 deg diameter or more.

Applications

In rapidly flickering sources such as video displays or fluorescent lights, flicker is most readily detected when the target subtends a large angle at the viewer's eye, because the

periphery of the retina is more sensitive to flicker than the fovea. An observer's likelihood of detecting flicker increases as the observer approaches the target and decreases as the observer moves away from the visual target.

Methods**Test Conditions**

- Observer viewed light source (target) through Bausch and Lomb binocular microscope; amount of illumination controlled by varying diameter of circular opening in template attached to microscope stage; target diameter of 5.0, 6.7,

16, 24, and 40 deg visual angle; dark background

- Time-averaged luminance of target varied from ~ 0.19 - 573 cd/m^2 (~ 0.06 - 180 mL) (Fig. 1 shows data for 16.8 and 78 cd/m^2)
- Light flickered on and off with square-wave modulation, 50% duty cycle; flicker rates of 15-75 Hz

- **Binocular** viewing, natural pupils; observer fixated center of target
- 3-sec exposure per trial
- Observer **light-adapted** for 5 min before experimental session; room illumination of 32.3 lux

- Independent variables: target diameter, target luminance
- Dependent variable: flicker-fusion threshold (CFF)
- Observer's task: judge test light as steady or flickering
- Two threshold settings obtained for each target diameter
- 3 observers with extensive practice

Experimental Procedure

- Ascending method of limits

Experimental Results

- CFF increases linearly with the logarithm of target area.
- CFF is higher for all target areas at higher luminance levels.

Variability

Individual data reported, but standard deviations not calcu-

lated. All observers showed a linear increase in CFF with log target area.

Repeatability/Comparison with Other Studies

Figure 1 includes data from two earlier studies (Refs. 1, 3) for comparison. Reference 1 measured CFF for targets with average luminance of 16.9 cd/m^2 ; Ref. 2 used targets with average luminance of 78 cd/m^2 . Data from Ref. 4 obtained at lower luminance levels agree with the earlier results.

Constraints

- Increases in target area produce increases in CFF only when the area is added to the outer circumference of the target. No change in CFF occurs if area is added by filling in the center of a ring-shaped target (Ref. 5).

- Results may differ for targets not foveally fixated or under low-luminance (**scotopic**) conditions.
- Many factors, such as target shape, wavelength, age, degree of practice, etc., may affect flicker perception and should be considered in applying these data under different conditions (CRef. 1.501).

Key References

1. Allen, F. (1945). The delineation of retinal zones with dark tube vision. *Canadian Journal of Research*, 23A, 21-31.
2. Granit, R., & Harper, P. (1930). Comparative studies on the peripheral and central retina: II. Synaptic

reactions in the eye. *American Journal of Physiology*, 95, 211-228.

3. Piéron, H. (1935). L'influence de la surface rétinienne en jeu dans une excitation lumineuse intermittente sur la valeur des fréquences critiques de papillotement. *Comptes Rendus des Séances. Société de Biologie (Paris)*, 118, 25-28.

*4. Roehrig, W. C. (1959). The influence of area on the critical flicker-fusion threshold. *Journal of Psychology*, 47, 317-330.

5. Roehrig, W. C. (1959). The influence of the portion of the retina stimulated on the critical flicker-fusion threshold. *Journal of Psychology*, 48, 57-63.

Cross References

- 1.501 Factors affecting sensitivity to flicker;
- 1.505 Flicker sensitivity: effect of type of target and luminance level

1.508 Flicker Sensitivity: Effect of Target Spatial Frequency

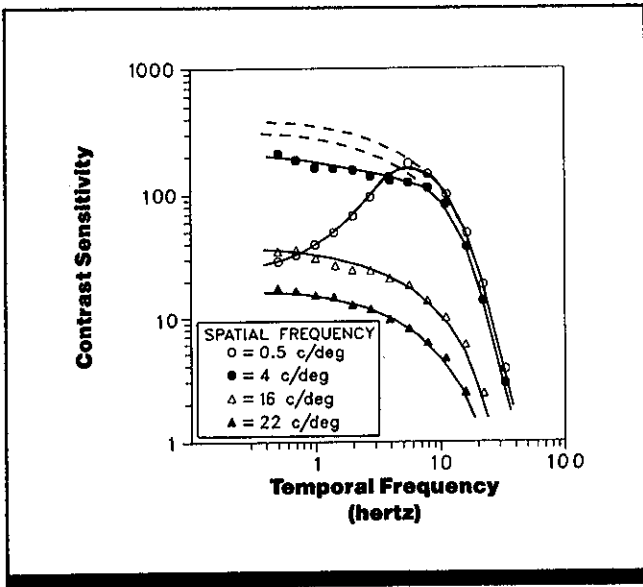

Figure 1. Contrast sensitivity (reciprocal of contrast threshold) for flickering sine-wave gratings as a function of temporal frequency (flicker rate) and spatial frequency (bar size) (Study 1). (From Ref. 4)

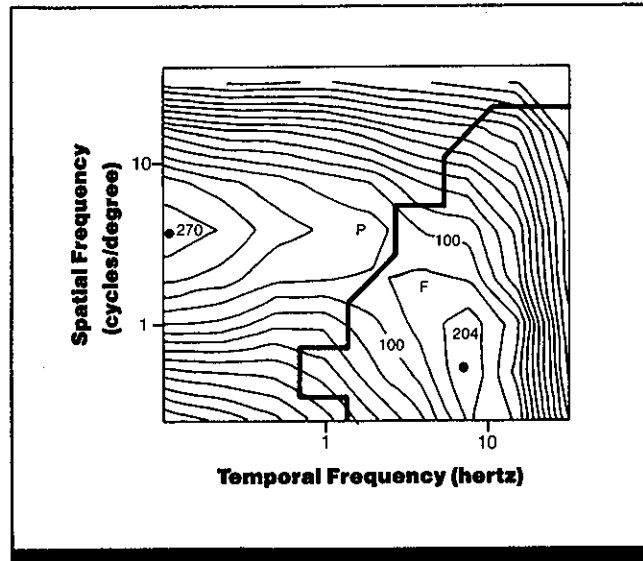

Figure 2. Isosensitivity contours for flickering sine-wave gratings (Study 2). Each curve connects points of equal sensitivity obtained by linear interpolation from data like those in Figure 1. The contour at sensitivity = 100, and the peaks at 270 and 204 are marked. The heavy line separates regions the observer judged as giving sensations of "flicker" (F) or "pattern" (P). (From Ref. 2)

Key Terms

Flicker detection; flicker frequency; modulation transfer function; temporal modulation

General Description

Contrast sensitivity for flickering sine-wave gratings (bar patterns) of low spatial frequency (wide bars) decreases at low temporal frequencies (flicker rates). When spatial frequency is high, however, sensitivity changes little with temporal frequencies less than ~5-10 Hz, i.e., no such decline in sensitivity is seen at low temporal frequencies. At high temporal frequencies, the shape of the temporal con-

trast sensitivity function does not vary with spatial frequency. When the temporal contrast sensitivity function is plotted as an equal sensitivity contour, sensitivity to both flicker and pattern detection declines when both spatial and temporal frequencies are high, or when both are low. Furthermore, beyond 10 Hz and 10 cycles per deg, spatial and temporal contrast sensitivity functions are separable.

Applications

Designs of displays whose temporal and spatial properties will provide maximum operator sensitivity; viewing environments in which operator sensitivity to flicker and/or contour is crucial.

Methods**Test Conditions****Study 1 (Ref. 4)**

- Sine-wave gratings with spatial frequency of 0.5, 4, 16, or 22 cycles per deg
- Grating flickered sinusoidally at 0.5-30 Hz
- Grating subtended 2.5 deg of visual angle square in center of 10-deg-square CRT screen
- Mean luminance of grating 20 cd/m²
- Binocular viewing; viewing distance 2 m

Study 2 (Ref. 2)

- Sine-wave gratings with spatial frequencies of 0.25, 1, 4, or 16 cycles per deg
- Gratings flickered sinusoidally in counterphase at 0.1, 0.48, 1.91, 7.63, or 30.52 Hz
- Modified TV monitor; frame frequency 61 Hz, 256 lines
- Monocular viewing through 2-mm diameter artificial pupil
- Mean luminance of 100 cd/m² (200 trolands)
- Target extent 4-deg square; dark surround

Experimental Procedure**Study 1**

- Method not specified, probably method of adjustment or constant stimuli
- Independent variables: temporal frequency, spatial frequency
- Dependent variable: contrast threshold
- Observer's task: not specified, but probably consisted of adjusting contrast of grating until contours could just be seen
- Four trials per point
- 1 highly trained observer

Study 2

- Method not specified, probably method of adjustment or constant stimuli
- Independent variables: spatial frequency, temporal frequency
- Dependent variable: contrast threshold
- Observer's task: not specified, but probably report perception of either contours (pattern detection) or flicker (flicker detection)
- Number of trials not specified
- 4 observers

Experimental Results

- For gratings of low spatial frequency (0.5 cycles/deg), contrast sensitivity peaks at a temporal (flicker) frequency of ~5-7 Hz and decreases at lower and higher temporal frequencies (Fig. 1).
- Contrast sensitivity for gratings of high spatial frequency (>4 cycles/deg) decreases at high temporal frequencies, but no decline in sensitivity is seen at low temporal frequencies (Fig. 1).
- At high temporal frequencies, the shape of the temporal contrast sensitivity function does not vary with spatial frequency. Also, at high spatial frequencies, the temporal contrast sensitivity function does not vary with temporal frequency. These invariances imply that, at the frequencies examined here, spatial and temporal contrast sensitivities are separable; that is, the decline in contrast sensitivity at high spatial frequencies is independent of temporal frequency and vice versa. This is not the case at low spatial and temporal frequencies. Declines in sensitivity at low spatial frequencies occur only when the temporal frequency is low and vice versa.

- Figure 2 plots isosensitivity contours (curves connecting points of equal sensitivity) obtained by linear interpolation from contrast sensitivity functions for flickering sine-wave gratings. Isosensitivity curves are shown for both pattern detection (*P* region) and flicker detection (*F* region), delineated by the heavy line. The parallel contours beyond 10 Hz and 10 cycles/deg indicate that contrast sensitivity at high spatial frequencies is independent of temporal frequency and vice versa. Furthermore, at spatial frequencies <1 cycle per deg, and temporal frequencies <1 Hz, sensitivity will decrease only when both spatial and temporal frequencies are low.

Variability

No information on variability reported for Study 1. For Study 2, the distance between isosensitivity curves is 0.1 log unit, which corresponds to ~1 standard deviation.

Repeatability/Comparison with Other Studies

Study 2 demonstrates that the spatiotemporal contrast detection threshold surface is bimodal; earlier work (Refs. 1, 4, 6) describes the surface as unimodal. The effects shown in Study 1 with sinusoidal gratings have also been demonstrated using square-wave gratings (Refs. 3, 5).

Constraints

- Target distance from fixation not specified in Study 2; peripheral viewing would reduce the effective spatial frequency of the target and contrast sensitivity and temporal sensitivity would more closely resemble low spatial frequency performance.

- Many factors (such as luminance level, exposure time, and target location in the visual field) influence sensitivity to flicker and must be considered in applying these results under different conditions (CRef. 1.501).

Key References

1. Kelly, D. H. (1966). Frequency doubling in visual responses. *Journal of the Optical Society of America*, 56, 1628-1633.
- *2. Koenderink, J. J., & van Doorn, A. J. (1979). Spatiotem-

poral contrast detection threshold surface is bimodal. *Optics Letters*, 4, 32-34.

3. Kulikowski, J. J., & Tolhurst, D. J. (1973). Psychophysical evidence for sustained and transient mechanisms in human vision. *Journal of Physiology*, 232, 149-163.

- *4. Robson, J. G. (1966). Spatial and temporal contrast-sensitivity functions of the visual system. *Journal of the Optical Society of America*, 56, 1141-1142.
5. Schober, H. A. W., & Hiltz, R. (1965). Contrast sensitivity of the

human eye for square-wave gratings. *Journal of the Optical Society of America*, 55, 1086-1091.

6. van Nes, F. L., Koenderink, J. J., Nas, H., & Bouman, M. A. (1967). Spatiotemporal modulation transfer function in the human eye. *Journal of the Optical Society of America*, 57, 1082-1088.

Cross References

- 1.501 Factors affecting sensitivity to flicker;
- 1.503 Flicker sensitivity: effect of flicker frequency and luminance level;

- 1.507 Flicker sensitivity: effect of target size;
- 1.509 Flicker perception versus pattern perception in temporally modulated targets

1.509 Flicker Perception Versus Pattern Perception in Temporally Modulated Targets

Key Terms

Flicker detection; pattern detection; size; target detection; temporal contrast sensitivity; temporal modulation

General Description

The flicker and spatial structure of a flickering bar pattern do not always appear simultaneously as the amplitude of the luminance modulation is increased from zero. A slowly-flickering target is first detected as a steady pattern and more contrast is required before the flicker is also perceived. On the other hand, a rapidly flickering target is first detected as a flickering field and more contrast is required before its spatial structure is also perceived.

Applications

When observers must respond to flickering patterns of low contrast, such as CRT or radar displays, the flicker will be more visible than the spatial pattern when the flicker rate is high, and the pattern will be more visible than the flicker when the flicker rate is low. The observer will be best at detecting the fine spatial details of a pattern if the pattern is stationary or flickering very slowly. Conversely, if the observer must detect the flicker, performance will be best when the spatial pattern is coarse (low spatial frequency); performance is greatly reduced when the pattern contains fine details (high spatial frequencies).

Methods

Test Conditions

- Targets were sine-wave gratings electronically generated on CRT screen; gratings luminance-modulated sinusoidally in time
- Target filled circular field 6 deg in diameter; average luminance 100 cd/m²
- Binocular viewing with natural pupils
- Flicker rate 0-30 Hz; spatial frequency of bar pattern 0.8 and 12 cycles/deg

Experimental Procedure

- Method of adjustment

- Independent variables: flicker rate, spatial frequency of bar pattern
- Dependent variables: contrast threshold for flicker detection, contrast threshold for pattern detection (where contrast is defined as Michelson contrast)
- Observer's task: adjust target contrast (1) until flicker is just detectable, regardless of whether spatial structure is seen, or (2) until spatial structure is just detectable, regardless of whether flicker is seen
- 2 observers, with extensive practice; confirming data obtained from several naive observers

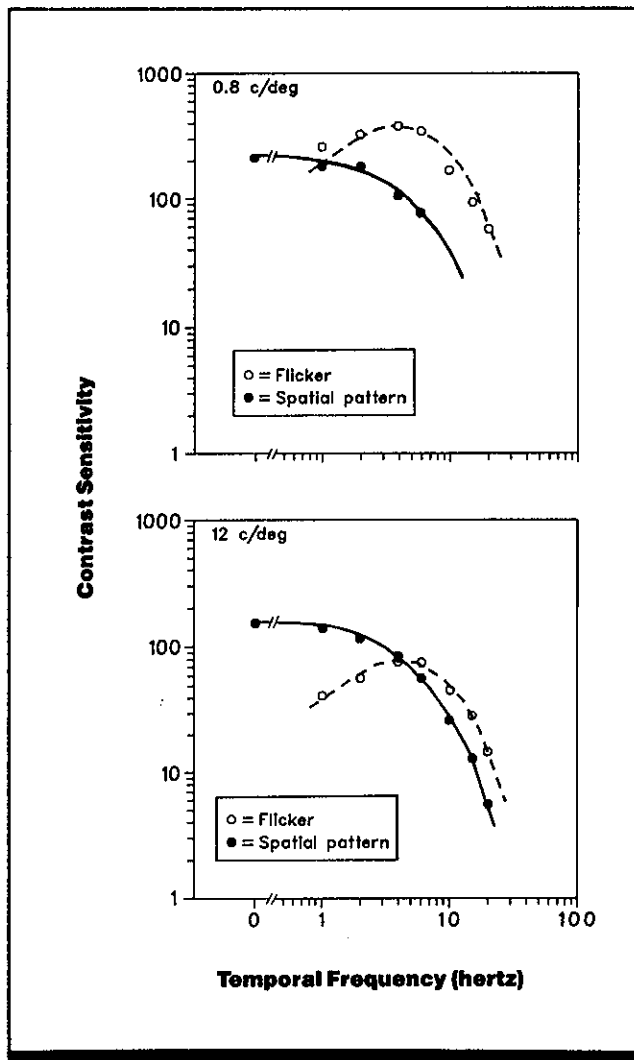

Figure 1. Contrast sensitivity for flickering bar patterns as a function of temporal frequency with flicker and pattern criteria. Open symbols: observer adjusted contrast until target appeared to flicker; closed symbols: observer adjusted contrast until spatial pattern seen. Target was a coarse bar pattern (0.8 cycle/deg, upper panel) or a fine bar pattern (12 cycle/deg, lower panel). Data shown are for a single observer. (From Ref. 1)

Experimental Results

- For rapidly flickering targets, flicker is detected at a lower contrast than spatial structure.
- For slowly flickering targets, spatial structure is detected at a lower contrast than flicker.
- Sensitivity to spatial structure is best when targets are steady or flickering very slowly, and falls off rapidly when the targets are flickering rapidly.
- Sensitivity to flicker is best at ~5 Hz, and falls at lower or higher rates.

- Flicker sensitivity, in general, is higher when the target has a coarse spatial pattern (low spatial frequency) than a fine spatial pattern (high spatial frequency).

Variability

Standard error of the mean of five threshold adjustments was 5-10%.

Repeatability/Comparison with Other Studies

Results conflict with those obtained using forced-choice methods (Ref. 2).

Constraints

- Results may vary with other factors known to affect spatial and temporal contrast sensitivity such as target area, position in visual field, and luminance level (CRefs. 1.628, 1.501).

Key References

*1. Kulikowski, J. J., & Tolhurst, D. J. (1973). Psychophysical evidence for sustained and transient detectors in human

vision. *Journal of Physiology*, 232, 149-162.

2. Lennie, P. (1980). Perceptual signs of parallel pathways. *Philosophical Transactions of the Royal Society of London*, B290, 23-27.

Cross References

1.501 Factors affecting sensitivity to flicker;

1.508 Flicker sensitivity: effect of target spatial frequency;

1.628 Factors affecting contrast sensitivity for spatial patterns;

Handbook of perception and human performance, Ch. 6, Sect. 9.4

1.510 Detection and Discrimination of Flicker Rate

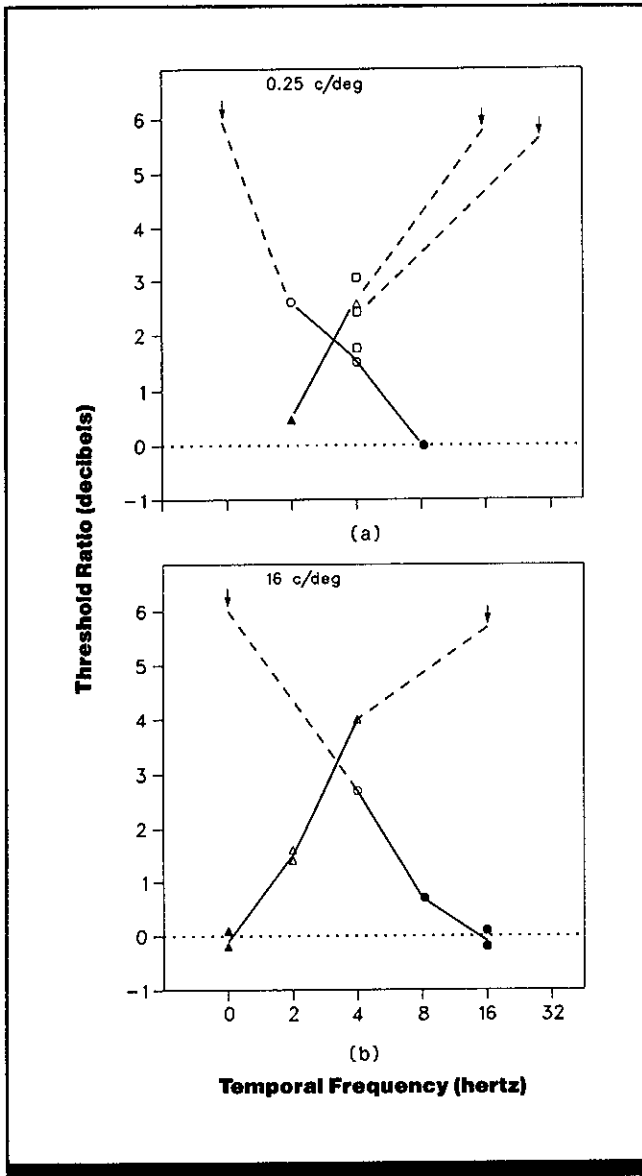

Figure 1. Ratio of identification and detection thresholds for sine-wave gratings flickering at different frequencies. In each experiment, gratings of two flicker frequencies were used, one indicated by the arrow and the other by the horizontal position of the data point. The ordinate shows the ratio of the contrast required for identification and the contrast required for detection of the gratings. When the ratio (in decibels) is equal to 0, detection and identification thresholds are equal and the flicker rates of the two gratings can be discriminated as soon as the gratings can be detected. Filled symbols denote cases in which a statistical test indicated that the two gratings could be perfectly discriminated (i.e., discriminated at detection threshold). Spatial frequencies of the gratings were (a) 0.25 cycles/deg and (b) 16 cycles/deg. (From Ref. 3)

Key Terms

Flicker detection; flicker discrimination; temporal frequency; temporal modulation

General Description

Ability to identify the flicker rate of a low-contrast target, or to correctly discriminate the flicker rates of two such targets flickering at different frequencies, is remarkably poor. For

example, when a 4-Hz target is just detectable, its flicker rate cannot be discriminated from that of a target flickering at 0 Hz. For these two flicker rates to be discriminated, the target contrasts must be well above detection threshold.

Methods

Test Conditions

- Patches of vertical sine-wave gratings (bar patterns), with contrast modulated sinusoidally in time; spatial frequencies of 0.25 or 16 cycles/degree
- Gratings presented as circular fields 1.5 periods (3 bars) wide

with blurred edges; mean target luminance of 340 cd/m²; large, equi-luminous background

- Target presented for 250 msec, with gradual onset and offset; flicker rate of 0-32 Hz
- Viewing distance varied between 57 and 228 cm
- Binocular viewing with natural pupils

Experimental Procedure

- Two-by-two forced choice paradigm in which one of two possible targets (slow or fast flicker rate) is presented in one of two temporal intervals per trial; intervals marked by tones
- Independent variables: flicker rate, spatial frequency

- Dependent variable: contrast at which target can be correctly detected or correctly identified on 82 percent of trials (determined from psychometric function obtained by fit of a Weibull function to the data)
- Observer's task: specify which interval contained the target and which flicker rate was presented
- Most data from 1 observer, with extensive practice; confirming data obtained from 3 other observers

Experimental Results

- A steady grating (0 Hz flicker) can be "perfectly discriminated" from a grating flickering at 8 Hz or higher (that is, the two gratings can be discriminated from one another as soon as they can be detected); gratings flickering at 2 Hz and at 16 Hz or higher are also perfectly discriminable ($p < 0.05$).
- Targets which differ less in flicker rate cannot be discriminated from one another at detection threshold contrast, but they can be distinguished when their contrasts are increased somewhat above the detection threshold.

- These results apply both to fine bar patterns (16 cycles/deg) and to coarse patterns (0.25 cycles/deg).
- Results suggest that observers can perceive only two flicker qualities in barely detectable targets: "slow" and "fast."

Variability

Data analyzed using likelihood ratio test of the hypothesis that flicker rate of a target can be discriminated as soon as the target is detected. No specific information on variability was given; all observers tested showed similar results.

Constraints

- Poor flicker discriminability applied only to targets with contrast at or near detection threshold; when contrast is approximately doubled, discriminability is improved (e.g., targets flickering at 2 Hz and 4 Hz can be discriminated).

- Many factors (such as luminance level, exposure time, and target location in the visual field) influence sensitivity to flicker and must be considered in applying these results under different conditions (CRef. 1.501).

Key References

1. Mandler, M. B. (1984). Temporal frequency discrimination above threshold. *Vision Research*, 12, 1873-1880.

2. Mandler, M. B., & Makous, W. (1984). A three-channel model of temporal frequency perception. *Vision Research*, 12, 1881-1887.

*3. Watson, A. B., & Robson, J. G. (1981). Discrimination at threshold: Labelled detectors in human vision. *Vision Research*, 21, 1115-1122.

Cross References

- 1.501 Factors affecting sensitivity to flicker;
- 1.509 Flicker perception versus

pattern perception in temporally modulated targets;
Handbook of perception and human performance, Ch. 6, Sect. 9.4

1.511 Factors Affecting Sensitivity to Brief (Pulsed) Targets

Key Terms

Exposure duration; interstimulus interval; light adaptation; luminance; pulse target; size; target detection

General Description

Visual sensitivity to transient or pulsed (briefly presented) targets is influenced by a number of factors, including exposure duration, target intensity, and target size. Typically, studies of sensitivity to transient targets are interested in how threshold intensity for a target changes as a function of target duration, and how different variables such as target luminance and size affect this relationship. In early re-

search, targets were most often spots of light, but recently **sine-wave gratings** (bar patterns) have also been used to study sensitivity for transient targets. The table lists several variables known to influence sensitivity (reciprocal of threshold intensity) for transient targets, indicates the nature of their effects, and cites entries or sources providing further information.

Constraints

• Interactions occur among the variables affecting sensitivity. Not all such interactions have been investigated. The table can be used to determine if an interaction between two

variables has been studied by noting when the same reference number appears in more than one row. For example, Ref. 1 considered the interaction between duration and spatial frequency for sine-wave grating targets.

Variable	Spatial Target	Effect on Sensitivity	References
Duration	Foveal disk	<ul style="list-style-type: none"> • Up to some critical duration, sensitivity increases (threshold intensity decreases) in inverse proportion to exposure duration; above the critical duration, increasing the length of exposure has no effect; the exact value of the critical duration varies with target characteristics and viewing conditions; typical values are ~20-100 msec 	Refs. 2, 6, 15; CRef. 1.512
	Sine-wave gratings	<ul style="list-style-type: none"> • Sensitivity increases with increasing duration 	Ref. 1
Background Intensity	Foveal disk	<ul style="list-style-type: none"> • Sensitivity with increasing background intensity 	Refs. 2, 7, 9, 10, 11, 16
	Peripheral disk	<ul style="list-style-type: none"> • Sensitivity decreases with increasing background intensity 	Refs. 4, 14
Interstimulus interval between two flashes	Foveal disk	<ul style="list-style-type: none"> • Sensitivity increases to 16 msec, slower increase up to 64 msec, a slight drop in sensitivity at 100 msec 	Ref. 15
Size	Foveal disk	<ul style="list-style-type: none"> • Sensitivity increases with increasing size 	Refs. 2, 16; CRef. 1.512
	Peripheral disk	<ul style="list-style-type: none"> • Sensitivity increases with increasing size 	Refs. 3, 4, 8, 14
Spatial frequency	Sine-wave grating	<ul style="list-style-type: none"> • Sensitivity highest at 3 cycles/deg, drops off at higher and lower spatial frequencies, especially beyond about 5 cycles/deg 	Refs. 1, 5, 12, 18, 19
	Square-wave grating	<ul style="list-style-type: none"> • Same as for sine-wave gratings, except data unclear below 2-3 cycles/deg 	Refs. 13, 17
Stabilization of retinal image	Sine-wave grating	<ul style="list-style-type: none"> • For presentation durations less than 7 sec, sensitivity is reduced less than 0.3 log units; larger reductions occur only when target is presented for an indefinite period 	Ref. 17; CRef. 3.112

Key References

1. Arend, L. E. (1976). Response of the human eye to spatially sinusoidal gratings at various exposure durations. *Vision Research*, *16*, 1311-1317.
2. Barlow, H. B. (1958). Temporal and spatial summation in human vision at different background intensities. *Journal of Physiology*, *141*, 337-350.
3. Baumgardt, E., & Hillman, B. (1961). Duration and size as determinants of peripheral retinal response. *Journal of the Optical Society of America*, *51*, 340-344.
4. Bouman, M. A. (1950). Peripheral contrast thresholds of the human eye. *Journal of the Optical Society of America*, *40*, 825-832.
5. Brietmeyer, B. G., & Ganz, L. (1977). Temporal studies with flashed gratings: Inference about human transient and sustained channels. *Vision Research*, *17*, 861-865.
6. Brindley, G. S. (1952). The Bunsen-Roscoe law for the human eye for very short durations. *Journal of Physiology*, *118*, 135-139.
7. Graham, C. H., & Kemp, E. H. (1938). Brightness discrimination as a function for the duration of the increment intensity. *Journal of General Physiology*, *21*, 635-650.
8. Graham, C. H., & Margaria, R. (1935). Area and intensity-time relation in the peripheral retina. *American Journal of Physiology*, *113*, 299-305.
9. Herrick, R. M. (1956). Foveal luminance discrimination as a function of the duration of the decrement or increment in luminance. *Journal of Comparative Physiology*, *59*, 437-443.
10. Keller, M. (1941). The relation between the critical duration and intensity in brightness discrimination. *Journal of Experimental Psychology*, *28*, 407-418.
11. Krauskopf, J., & Mollon, J. D. (1971). The independence of the temporal integration properties of the individual chromatic mechanisms in the human eye. *Journal of Physiology*, *219*, 611-623.
12. Legge, G. E. (1978). Sustained and transient mechanisms in human vision: Temporal and spatial properties. *Vision Research*, *18*, 69-81.
13. Nachmias, J. (1967). Effect of exposure duration on visual contrast sensitivity with square-wave gratings. *Journal of the Optical Society of America*, *57*, 421-427.
14. Owen, W. G. (1972). Spatio-temporal integration in the human peripheral retina. *Vision Research*, *12*, 1011-1026.
15. Rashbass, C. (1970). The visibility of transient changes of luminance. *Journal of Physiology*, *210*, 165-186.
16. Roufs, J. A. J. (1972). Dynamic properties of vision-I. Experimental relationships between flicker and flash thresholds. *Vision Research*, *12*, 261-278.
17. Schober, H. A. W., & Hiltz, R. (1965). Contrast sensitivity of the human eye for square-wave gratings. *Journal of the Optical Society of America*, *55*, 1086-1091.
18. Tolhurst, D. J. (1975). Reaction times in the detection of gratings by human observers: A probabilistic mechanism. *Vision Research*, *15*, 1143-1149.
19. Tulunay-Keesey, U., & Jones, R. M. (1976). The effect of micro-movements of the eye and exposure duration on contrast sensitivity. *Vision Research*, *16*, 481-488.

Cross References

- 1.512 Time-intensity trade-offs in detection of brief targets: effect of duration, target intensity, and background luminance;
- 3.112 Vibrotactile stimulation: perceived magnitude as a function of number of active vibrators

1.512 Time-Intensity Trade-Offs in Detection of Brief Targets: Effect of Duration, Target Intensity, and Background Luminance

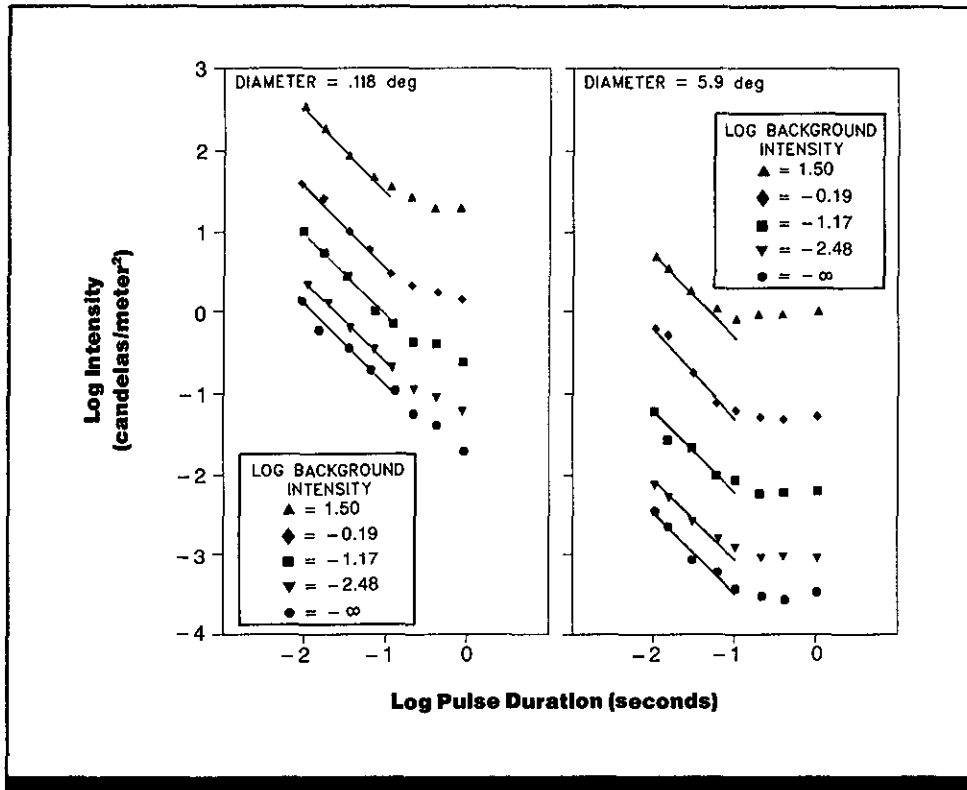

Figure 1. Log threshold intensity for a rectangularly, pulsed target as a function of log pulse duration. Target disk diameter is 0.118 deg in the left panel, and 5.9 deg in the right. Data are shown for 5 background intensities. (From Ref. 1)

Key Terms

Bloch's Law; critical duration; exposure duration; light adaptation; luminance; pulse target; target detection; temporal summation

General Description

When the exposure time of a brief target (pulse) is below some critical duration, the threshold intensity for detection of the pulse is inversely proportional to pulse duration (i.e., there is temporal summation of light energy). This relation is known as Bloch's Law, and can be expressed as $IT = k$ where I is threshold intensity, T is target duration, and k is a constant equal to the product of the critical duration and the threshold intensity at the critical duration (critical intensity). Bloch's Law has been found to hold for most briefly presented targets under a wide variety of viewing conditions.

Outside of the region where Bloch's Law holds, threshold intensity declines less rapidly with increasing duration. For large targets, the threshold function quickly flattens out and increasing duration ceases to have any effect on threshold intensity. With small targets, the departure from Bloch's Law is more gradual, and duration continues to have a small effect on thresholds. This makes it difficult to measure critical duration for such targets.

Critical duration varies with background luminance. It ranges for ~ 25 msec at high background luminances to ~ 100 msec for dark backgrounds (Fig. 2a).

Methods

Test Conditions

- Target was disk 0.118 or 5.9 deg in diameter centered 6 deg 30 min of visual angle from fovea in lower nasal quadrant of observer's right eye

- Target turned off and on as rectangular pulse; duration ranged from 8.5 to 930 msec; target presented once every 3 sec
- Target presented against 13-deg diameter background; five background intensities ranging from zero to 32 cd/m² entering the eye

- Viewing through 2 mm-diameter artificial pupil

Experimental Procedure

- Method of adjustment
- Independent variables: diameter of target, duration of target presentation, intensity of background

- Dependent variable: target intensity at threshold (which corresponded roughly to the "80%-seen" intensity (of frequency-of-seeing curves))
- Observer's task: adjust intensity of flash so that it was just visible on most repetitions
- 2 highly practiced observers

Experimental Results

- When log intensity of the target at threshold is plotted against log exposure duration, the resulting functions have two segments for both large and small targets. For exposure times below some critical duration (ranging from ~25-100 msec depending on target size and background level) threshold intensity decreases approximately inversely with duration. That is, at these durations, the data are in conformity with Bloch's Law (represented in Fig. 1 by the line with a slope of -1).
- At durations above the critical duration, the function levels off. The slope of the function is zero for larger targets, indicating that duration no longer has any effect on threshold intensity. For smaller targets, however, the slope never reaches zero at the durations used; increases in target duration continue to produce slight decreases in threshold intensity (this makes it difficult to determine a critical duration for small targets).
- Targets of 0.118 deg require more luminance for detection than targets of 5.9 deg at the same exposure duration.
- The critical duration decreases as background intensity increases and as target size increases.
- Figure 2a plots the results of several studies showing how critical duration decreases as background intensity increases. Critical duration declines from ~100 msec for targets viewed against very dim or dark backgrounds to ~25 msec for targets against very bright backgrounds.
- The critical intensity increases as background intensity increases (Fig. 2b).

Variability

No information on variability given. Figure 2 shows spread of results for several studies using targets of similar size.

Repeatability/Comparison with Other Studies

See Fig. 2. One study (Ref. 6) reported similarity among findings of several different experiments on critical duration and intensity as a function of background illumination for targets of 1-deg diameter. Another study (Ref. 5), using sinusoidal gratings instead of rectangular pulses, found evidence for Bloch's Law, with the critical duration varying with spatial frequency. For spatial frequencies 1.5 cycles/deg and above, the threshold shows an initial decline until 100 msec, then a shallower decline up to ~1000 msec. Below 1.5 cycles/deg, Bloch's Law does not hold for critical durations >100 msec.

Constraints

- The published literature shows no significant violations of Bloch's Law for targets with durations of <20 msec.
- Critical duration depends on the temporal waveform of

Key References

- *1. Barlow, H. B. (1958). Temporal and spatial summation in human vision at different background intensities; *Journal of Physiology*, 141, 337-350.
2. Graham, C. H., & Kemp, E. H.

- (1938). Brightness discrimination as a function of the duration of the increment intensity. *Journal of General Physiology*, 21, 635-650.
3. Herrick, R. M. (1956). Foveal luminance discrimination as a function of the duration of the decrement or increment in luminance.

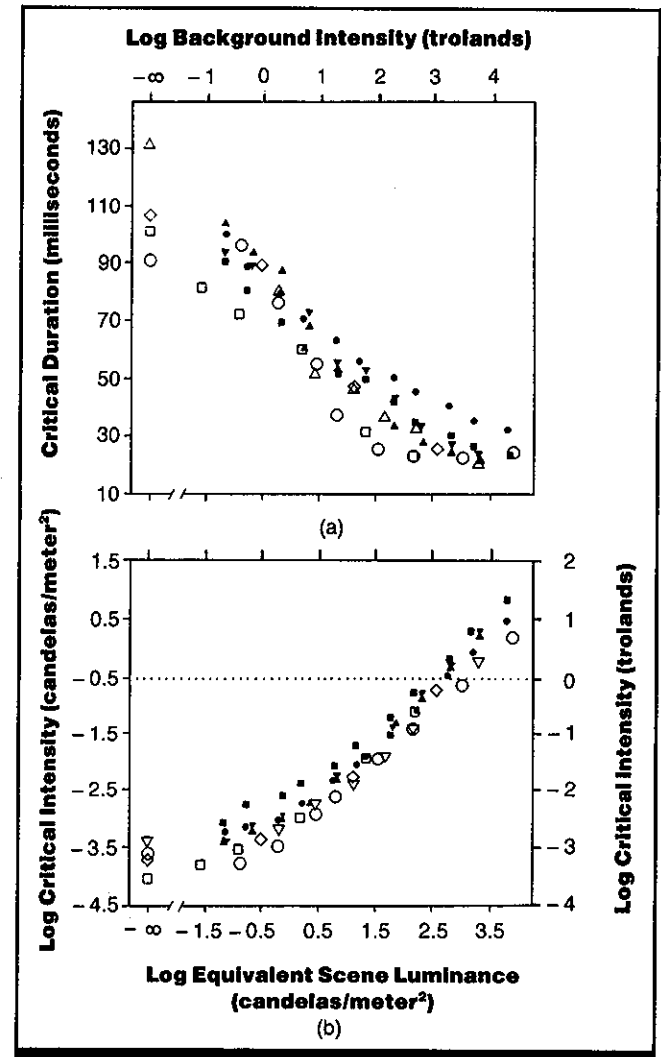

Figure 2. Critical duration and critical intensity as functions of background intensity. Critical duration is the longest duration of the target pulse for which reciprocity holds between intensity and duration. The critical intensity is the threshold intensity at the critical duration. Filled circles are averages for 8 subjects (Ref. 2), filled squares are averages for 2 subjects (Ref. 4), filled triangles are averages for 2 subjects (Ref. 3), open symbols are individual subjects from Ref. 6. Target was a 1-deg, semi-circular disk (Refs. 2, 4) or a 1-deg circular disk (Refs. 3, 6). (From Ref. 6)

the pulse and is different for sinusoidal than for rectangular pulses.

- Many factors influence sensitivity to brief (pulse) targets must be considered in applying the results presented here (CRef. 1.511).

Cross References

- 1.401 Brightness difference threshold: effect of background luminance;

- 1.402 Brightness difference threshold: effect of background luminance and duration of luminance increment;

- 1.511 Factors affecting sensitivity to brief (pulsed) targets; *Handbook of perception and human performance*, Ch. 6, Sect. 6.2, 11.5

- and transient mechanisms in human vision: Temporal and spatial properties. *Vision Research*, 18, 69-81.
6. Roufs, J. A. J. (1972). Dynamic properties of vision-I. Experimental relationships between flicker and flash thresholds. *Vision Research*, 12, 261-278.

1.513 Model of Temporal Sensitivity

Key Terms

Flicker detection; light adaptation; temporal modulation

General Description

It is possible to mathematically specify a linear system with a transfer function that simulates the way the visual system responds to a wide variety of time-varying stimuli. Such a model provides a general understanding of the possible mechanisms underlying the processing of temporal signals, and can predict the visual effects of stimuli of practically any temporal waveform.

In the model described here, the input signal is assumed to pass through a multistage linear low-pass filter. The filter contains n_1 stages ($n_1 = 9$ in most applications) representing an excitatory mechanism, and n_2 stages ($n_2 = 10$ in most applications) representing an inhibitory mechanism. The output signal is the difference between the outputs of these two mechanisms, with the inhibitory component multiplied by a weighting factor ζ between 0 and 1. This difference is then multiplied by a second weighting factor ξ to set the overall gain of the system.

Each stage of the excitatory filter is assumed to have a time constant θ (~ 5 msec) to simulate conditions of moderate light adaptation. The impulse response of this filter is

$$h_1(t) = u(t) [\tau(n_1 - 1)!]^{-1} (t/\tau)^{n_1 - 1} e^{-t/\tau}$$

where $u(t)$ represents a unit step function. The impulse response of the inhibitory filter is similar to the preceding, but with n_2 stages, and a time constant which is K times longer than τ (in most applications, K is assumed to be 1.33). The output of these filters is assumed to be

$$h(t) = \xi(h_1(t) - \zeta h_2(t))$$

where the weighting factor ξ scales the response amplitude, and the weighting factor ζ specifies the relative contribution of the inhibitory mechanism to the output. When $\zeta = 1$, the system is transient in the sense that it responds to a step input with a brief increase, which then decays to zero; when $\zeta = 0$, the system is sustained in the sense that it responds to a step input by rising to a steady maintained level. Figure 1a shows the model's impulse response under sustained (upper curve) and transient conditions (lower curve).

By applying a Fourier transformation to $h(t)$, it is possible to characterize the model's response in terms of amplitude and phase functions of temporal frequency (Figures 1b and 1c). The amplitude function simulates a temporal contrast sensitivity function, which is obtained by measuring the luminance modulation at which an observer can just detect flicker in a sinusoidally varying stimulus, as a function of flicker frequency. When the model operates as a sustained system, the amplitude function is continually decreasing and has a flat low-frequency limb, whereas, when the system is transient, the amplitude function has a steep low-frequency fall-off.

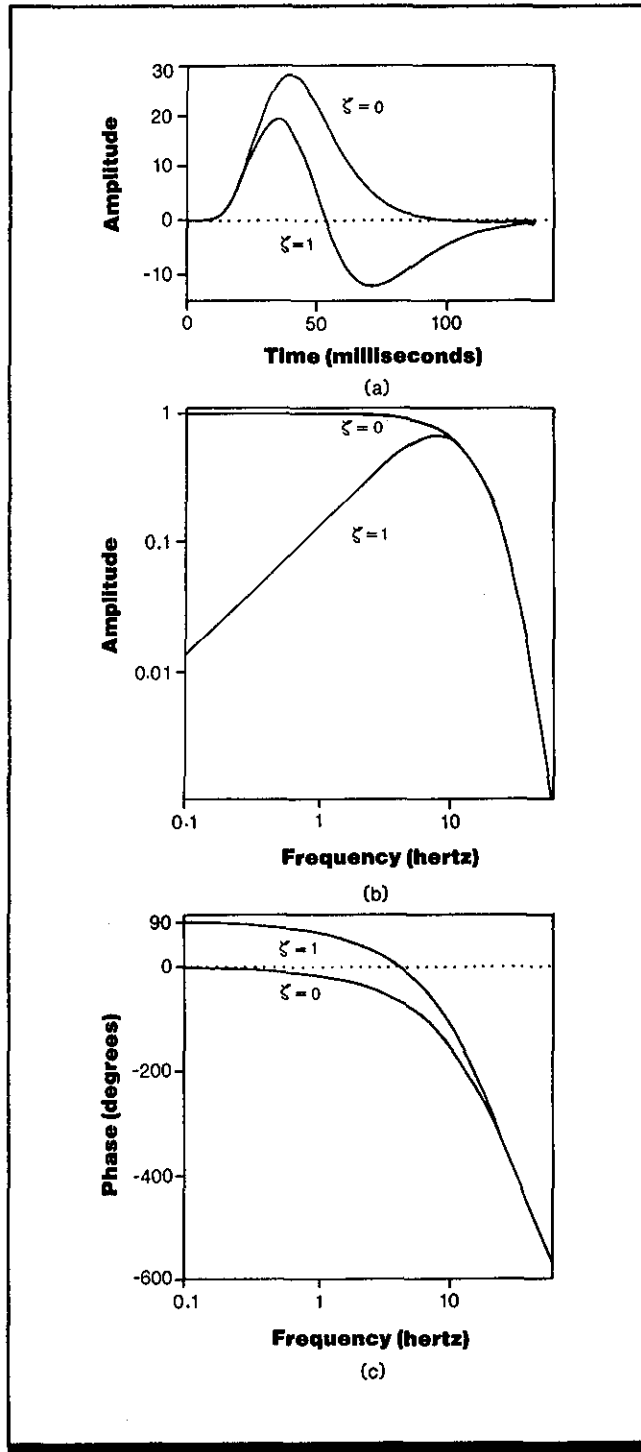

Figure 1. (a) Impulse response of model for extreme values (0 and 1) of the transience parameter. Other parameter values are $\tau = 4.94$ msec, $K = 1.33$, $n_1 = 9$, $n_2 = 10$, and $\xi = 1$. These values are appropriate for modeling the sensitivity of a typical human observer to temporal fluctuations in a uniform field of moderately high luminance. (b) Amplitude function and (c) phase function, respectively, of temporal frequency for same parameter values. (From Ref. 6)

Applications

The model specifies the system's response to any stimulus waveform, obtained mathematically by convolving the waveform with the model's impulse response $h(t)$. Then, by suitable choices of parameter values, the model can be adjusted to fit temporal sensitivity data obtained from that stimulus waveform under various conditions of average lu-

minance, target area, etc. In most cases n_1 , n_2 , and K can be considered fixed properties of the system and need not be changed as a function of stimulus conditions. To fit temporal contrast sensitivity data, the parameter ξ is used to scale the model's amplitude function vertically, the parameter τ scales the function horizontally, and ζ adjusts the shape of the function of low frequencies.

Empirical Validation

Figure 2 shows how the model's output fits temporal contrast sensitivity data from three studies. Similarly, the

model may be used to simulate visual sensitivity data obtained using brief flashes, pulse pairs, and other stimuli.

Constraints

- The model must be modified slightly to account for data in which both luminance increments and decrements are used, because the visual system seems to be somewhat more sensitive to decrements than to increments of equal magnitude. This asymmetry can be taken into account by multiplying the system's output by the factor ρ whenever the output is positive.
- When the model is used to predict sensitivity to stimulus waveforms of various durations, it may be necessary to allow for the effects of probability summation, which in-

creases the detectability of longer duration targets relative to briefer duration targets of equal intensity, even when the system's sensitivity is constant (see Ref. 6).

- Other models have been proposed for temporal sensitivity (Refs. 1, 2); these models may fit data as well as the model described here.

- The model may be used to predict visual response to a single, non-moving, flickering pattern near detection threshold. Its expected applicability for suprathreshold, spatiotemporally complex targets is very small.

Key References

1. de Lange, H. (1958). Research into the dynamic nature of the human fovea cortex system with intermittent and modulated light. *Journal of the Optical Society of America*, 48, 777-789.

2. Rashbass, C. (1970). The visibility of transient changes of luminance. *Journal of Physiology*, 210, 165-186.

3. Robson, J. G. (1966). Spatial and temporal contrast sensitivity functions of the visual system. *Journal of the Optical Society of America*, 56, 1141-1142.

4. Roufs, J. A. J., & Blommaert, F. J. J. (1981). Temporal impulse and step responses of the human eye obtained psychophysically by means of a drift-correcting perturbation technique. *Vision Research*, 21, 1203-1221.

*5. Watson, A. B. (1979). Probability summation over time. *Vision Research*, 19, 515-522.

6. Watson, A. B. (1986). Temporal sensitivity. In K. R. Boff, L. Kaufman, & J. P. Thomas (Eds.), *Handbook of perception and human performance*. Vol. 1. *Sensory processes and perception*. New York: Wiley.

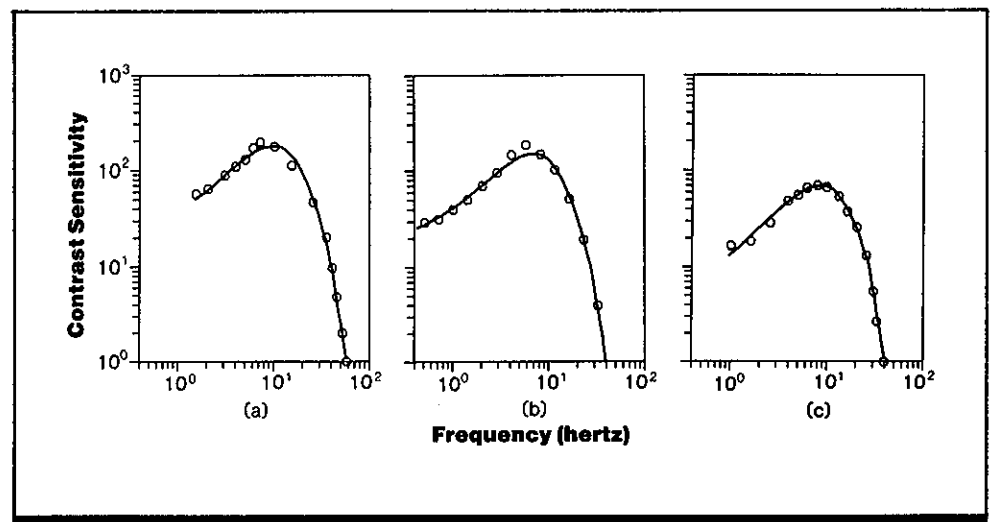

Figure 2. Temporal contrast sensitivity functions obtained empirically and predicted by the model. Open circles are data for human observers obtained by the method of adjustment. Standard deviations of the data were probably ~ 0.05 log unit. Curves are amplitude response functions as predicted by the model, with parameters adjusted to approximately match the data. The model parameters common to all three functions are: $n_1 = 9$, $n_2 = 10$, and $K = 1.33$. The parameters τ , ζ , ξ were individually adjusted for best fit for each experimental condition, as follows:

Data Source	Target	Mean Luminance	Surround	τ , msec	ζ	ξ
(a) Ref. 1	2 deg diam uniform disc	163 cd/m ²	163 cd/m ²	4.3	0.9	269
(b) Ref. 3	0.5 cycle/deg grating	20 cd/m ²	20 cd/m ²	6.22	0.9	214
(c) Ref. 4	1 deg diam uniform disc	382 cd/m ²	dark	4.94	1.0	200

(Figure from Ref. 6)

Notes



Section 1.6 Spatial Sensitivity

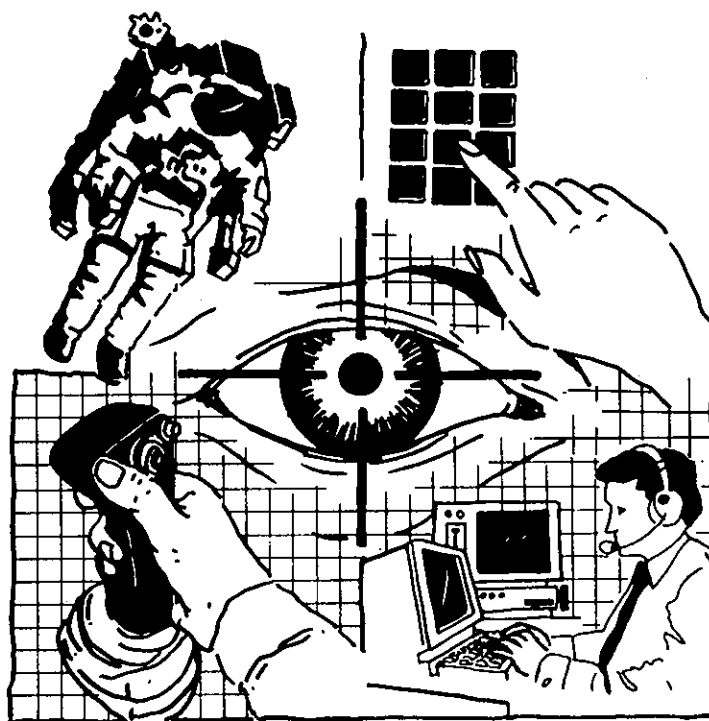

1.601 Luminance Description of Visual Patterns

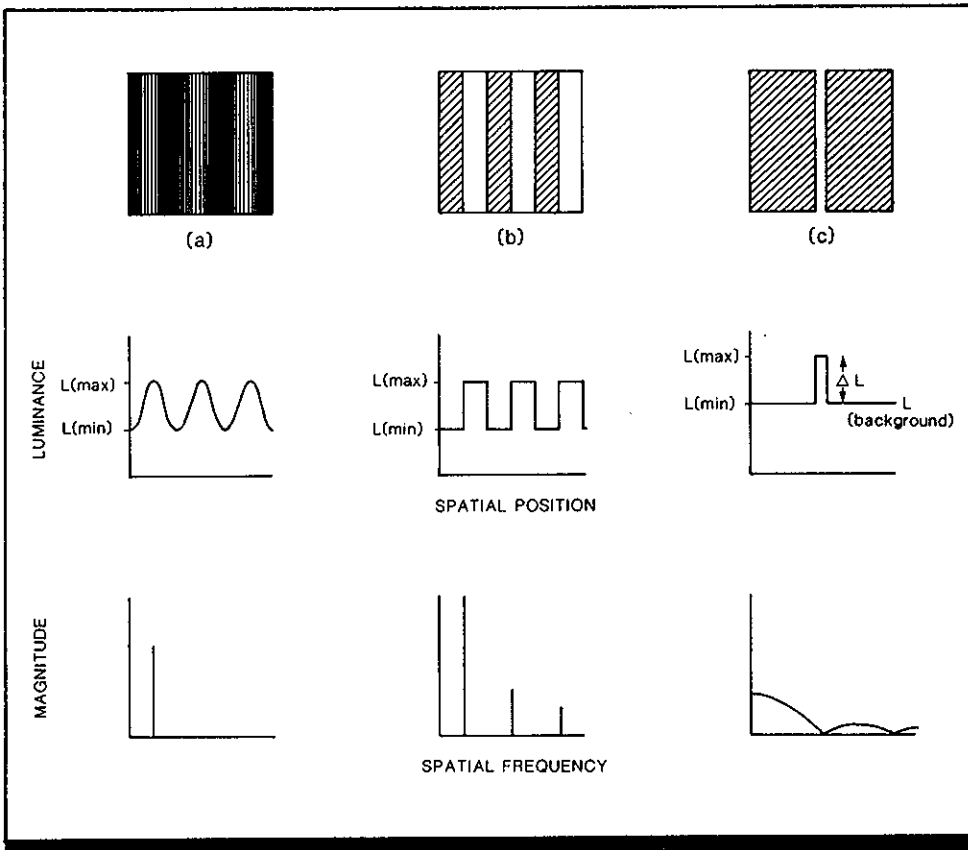

Figure 1. (a) Sine-wave grating (bar pattern); (b) square-wave grating; (c) single bar. For each of these one-dimensional patterns, the middle panel graphs the luminance profile and the lower panel graphs at least part of the energy spectrum. (From Ref. 3)

Key Terms

Achromatic contrast; contrast; contrast ratio; luminance; Michelson contrast; modulation transfer function; spatial frequency analysis

General Description

Many visual patterns are best described in terms of *luminance* variations across space and time. This *luminance profile* is simply a list or function $L(x, y, t)$ of luminance values for each coordinate (x, y) in space (or on the *retina*) at each point in time (t) . For static patterns the luminance profile reduces to $L(x, y)$. For time-varying patterns, $L(x, y, t)$ can be factored into $L(x, y)$ and $f(t)$ (Refs. 3, 4). Lists of luminance values are most useful for patterns that would be unwieldy to describe mathematically, but many patterns used in visual science are realizations of simple functions.

Because the visual system tends to respond to differences in luminance, the intensity of many stimuli is best described in terms of *contrast*; that is, the luminance difference between an object and its background or between parts of an object or scene. The difference in luminance is called luminous contrast, achromatic contrast, or relative contrast, which are terms that have the same meaning. For a simple luminance increment or decrement relative to the

background luminance (such as a single point), the *contrast ratio* can be defined as

$$\Delta L/L$$

or as

$$(L + \Delta L)/L$$

where L is the background luminance and ΔL is the increment or decrement in luminance. However, other ways of defining contrast are also often used.

For periodic stimuli that deviate symmetrically above and below a mean luminance value (e.g., gratings or bar patterns such as those in Fig. 1a and 1b), *Michelson contrast* (C_m) is generally used:

$$C_m = (L_{max} - L_{min}) / (L_{max} + L_{min})$$

where L_{max} and L_{min} are the maximum and minimum luminances in the pattern. The denominator of this formula is equal to twice the mean luminance, and it may be computationally convenient to compute this value only once when several patterns share the same mean luminance. Michelson

contrast can take on values between 0 and 1, and is also called modulation contrast, depth of modulation, or relative contrast about the mean luminance. The Michelson contrast is inappropriate for aperiodic patterns (such as the one shown in Fig. 1c) and periodic patterns that do not deviate symmetrically about a mean value because the mean luminance depends on the relative spatial extent of L_{max} and L_{min} in patterns such as these. Hence an assumption underlying the use of Michelson contrast is that the patterns are infinite in extent, rather than being confined to the actual dimensions of a display. (While it is sometimes recommended that modulation contrast, C_m , be applied only to a luminance distribution that is sinusoidal or quasi-sinusoidal, this suggestion is usually ignored.)

Unfortunately, the scientific literature contains (1) many different formulas for calculating contrast, (2) many different names for the same formulas, and (3) the same names for very different formulas (e.g., the contrast ratio of one author is another author's contrast). Often authors do not give the formulas that they used for calculating contrast. Table 1 lists three common terms used for contrast, along with the corresponding definitions and relevant information. When only the term "contrast" is used, it usually refers to a difference, ΔL divided by one of the values, L ; four different ways of calculating contrast ($\Delta L/L$) and the ranges of possible values are listed in Table 1. When the term contrast ratio (CR) is used, it often means maximum/minimum, where maximum (max) and minimum (min) refer to the highest and lowest luminances in a pattern. However, maximum/minimum is sometimes called luminance ratio. For each contrast formula or unit listed in Table 1, the value of the unit in terms of max/min or light/dark (L/D) is listed. L/D ratios can be equated to obtain an equation relating any two units, as shown at the bottom of Table 1. Table 2, which was derived by equating L/D ratios, lists 30 formulas or equations for converting values from one formulation to another.

Density, rather than luminance, is useful for describing back-lit material, such as a photographic negative or a photographic transparency; a quantity called delta density (Δd)

is sometimes used. It is defined as $\Delta d = \log_{10} [(L + \Delta L)/L]$ and is equivalent to $\log_{10} [(1 + C_m)/(1 - C_m)]$, or $\log_{10} (\text{max/min})$.

Fourier analysis of spatial frequency (number of luminance-modulation cycles per degree of visual angle for repetitive patterns) is increasingly popular as a means of describing the performance of the visual system as a whole and also of single neurons. As a result, stimulus patterns are often described in terms of their spatial frequency components. Mathematically, it is assumed that any visual pattern is equivalent to a uniform field equal to the mean luminance of the pattern as a whole, modulated by the linear sum of a set of sinusoidal luminance profiles. Each elemental sine wave has parameters describing its spatial frequency, orientation, phase, and contrast (see Ref. 3). For example, Fig. 1a is a pattern with only a single sinusoidal component that is vertically oriented.

The spectrum or Fourier transform of a pattern shows how much energy there is as a function of spatial frequency, and thus indicates the relative energy distribution of coarse and fine luminance variation. Each of the three patterns shown in Fig. 1 is one-dimensional and each spectrum (shown in the lower panel) can be represented on a two-dimensional plot. Because Fig. 1a consists of only one sine wave, all of the energy is concentrated at a single spatial frequency. The pattern in Fig. 1b has energy at many discrete spatial frequencies (only the lower three are shown) with the most variation at the fundamental (lowest) frequency of the bars; the pattern in Fig. 1c has variation that is continuously distributed within spatial frequency bands.

Contrast threshold is the smallest amount of luminance contrast between two adjacent spatial regions that can be detected on some specified percentage of trials. In visual research, contrast threshold is frequently measured using sine-wave grating patterns such as that in Fig. 1a.

Contrast sensitivity is usually expressed as the reciprocal of the contrast threshold, because it has sometimes been thought that greater sensitivity to contrast should yield a larger rather than a smaller number (as does contrast threshold).

Applications

Contrast sensitivity testing, image processing; conversion of contrast units of one kind to contrast units of a different kind; testing of visual performance.

Constraints

- Because Michelson contrast has no mean luminance parameter, equivalence between patterns with the same Michelson value should not be assumed.
- The spectra of spatial patterns ignore phase relationships among spatial frequency components.
- Negative values of Michelson contrast are sometimes used to denote patterns of opposite phase but the same contrast as their positive counterparts.
- Although contrast units may be algebraically converted to those of alternate definitions, equivalence should be assumed only when contrast definitions rely on equivalent assumptions.
- It cannot be assumed that an author uses a given label to refer to a particular formula; different authors use different labels for the same contrast formula. The reader must find the definition of (or formula for) contrast within each report.

- Reports do not always state that a formula is multiplied by 100 to convert contrast to a percentage.
- Only C_m is likely to be the same in all reports. Even Δd is suspect; some authors may use \log_e , not \log_{10} .
- Use of the same contrast formula in different reports does not reveal anything about the luminance level of the light and dark areas of a pattern.
- Real-world objects are almost never uniform in luminance over their surfaces and seldom appear on uniform backgrounds; they are not describable by one contrast value. Therefore, generalizing to such objects from test data obtained using uniform patterns on uniform backgrounds is likely to produce very large errors of prediction, particularly if target search is required and backgrounds are cluttered.

Key References

1. Bracewell, R. (1965). *The Fourier transform and its applications*. New York: McGraw-Hill.
 2. Farrell, R. J., & Booth, J. M. (1984). *Design handbook for imagery interpretation equipment*.

Seattle, WA: Boeing Aerospace Co.
 3. Olzak, L. A., & Thomas, J. P. (1986). Seeing spatial patterns. In K. R. Boff, L. Kaufman, & J. P. Thomas (Eds.), *Handbook of perception and human performance: Vol. 1. Sensory processes and perception*. New York: Wiley.

4. Watson, A. B. (1986). Temporal sensitivity. In K. R. Boff, L. Kaufman, & J. P. Thomas (Eds.), *Handbook of perception and human performance: Vol. 1. Sensory processes and perception*. New York: Wiley.

Cross References

1.104 Measurement of radiant and luminous energy

Table 1. Contrast definitions and ranges of possible values.

Label*	Formulation	Target	T & B**	Range	L/D = Max/Min
Contrast	$C = (\max - \min)/\max = (L - D)/L$	Light Dark	$(L_T - L_B)/L_T$ $(L_B - L_T)/L_B$	0 - 1	$1/(1 - C)$
	$C_1 = (\max - \min)/\min = (L - D)/D$	Light Dark	$(L_T - L_B)/L_B$ $(L_B - L_T)/L_T$	0 - ∞	$1 \pm C_1$
	$C_2 = (\min - \max)/\max = (D - L)/L$	Light Dark	$(L_B - L_T)/L_T$ $(L_T - L_B)/L_B$	0 - (-1)	$1/(1 + C_2)$
	$C_3 = (\min - \max)/\min = (D - L)/D$	Light Dark	$(L_B - L_T)/L_B$ $(L_T - L_B)/L_T$	0 - (-∞)	$1 - C_3$
Contrast Ratio (Luminance Ratio)	$CR = C_R = \max/\min = L/D$	Light	L_T/L_B	0 - ∞	CR
		Dark	L_B/L_T		
Modulation Contrast or Michelson Contrast	$C_M = (\max - \min)/(\max + \min) = (L - D)/(L + D)$	Light Dark	$(L_T - L_B)/(L_T + L_B)$ $(L_B - L_T)/(L_T + L_B)$	0 - 1	$(1 + C_M)/(1 - C_M)$

*Labels of different authors may refer to very different formulas.

**T & B: Contrast formulation in terms of target and background luminances

KEY: L = Light, D = Dark, both relative; L_T, L_B = target and background luminances; max, min are maximum and minimum luminances.

NOTE: Compare formulations by equating L/D ratios. Example: For C, $L/D = 1/(1 - C)$, and for C_M , $L/D = (1 + C_M)/(1 - C_M)$, thus $1/(1 - C) = (1 + C_M)/(1 - C_M)$, from which $C = 2C_M/(1 + C_M)$.

Table 2. Converting values of contrast formulations.

Available Contrast	Contrast Wanted					
	C_M	CR	C_3	C_2	C_1	C
C	$C/(2 - C)$	$1/(1 - C)$	$C/(C - 1)$	-C	$C/(1 - C)$	---
C_1	$C_1/(C_1 + 2)$	$1 + C_1$	$-C_1$	$-C_1/(1 + C_1)$	---	$C_1/(1 + C_1)$
C_2	$-C_2/(2 + C_2)$	$1/(1 + C_2)$	$C_2/(1 + C_2)$	---	$-C_2/(1 + C_2)$	$-C_2$
C_3	$C_3/(C_3 - 2)$	$1 - C_3$	---	$C_3/(1 - C_3)$	$-C_3$	$C_3/(C_3 - 1)$
CR	$(CR - 1)/CR + 1$	---	$1 - CR$	$(1 - CR)/CR$	$CR - 1$	$(CR - 1)/CR$
C_M	---	$(1 + C_M)/(1 - C_M)$	$2C_M/(C_M - 1)$	$-2C_M/(1 + C_M)$	$2C_M/(1 - C_M)$	$2C_M/(1 + C_M)$

Example: Have $C_3 = -4$, solve for C_M . Solution: $C_M = C_3/(C_3 - 2) = -4/(-4 - 2) = 2/3$.

Notes

1.602 Measurement of Visual Acuity

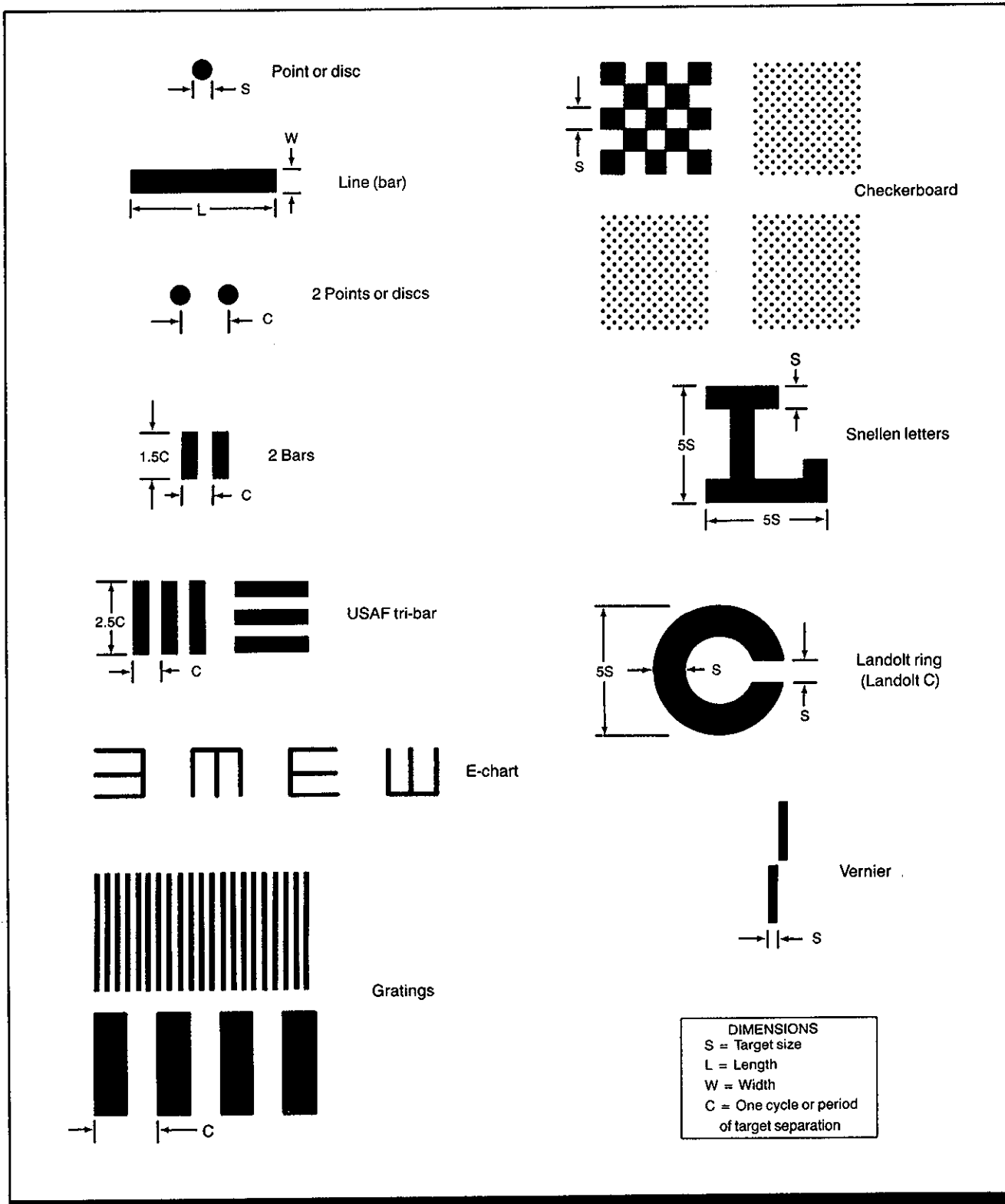

Figure 1. Some common targets for measuring visual performance and their control dimensions. (From Ref. 3)

Key Terms

Contrast sensitivity; pattern perception; Snellen acuity; spatial resolution; visual acuity; visual test patterns

General Description

Visual acuity is the ability to discriminate fine objects or the details of objects subtending small angles at the observer's eye. There are four distinct types or measures of visual acuity, each relating to the ability to discriminate a different aspect of detail:

1. **Minimum visibility:** ability to detect a point source of light (stars, illuminated pinholes).
2. **Minimum perceptibility:** ability to detect small objects against a plain background (small black dot, disc, or bar on a dark background, or white targets on a dark background).
3. **Minimum separability (minimum angle of resolution, resolving power, gap detection):** ability to see that two or more objects very close together are separate (two or more parallel bars, **sine-wave gratings**, two discs, checkerboards).
4. **Minimum distinguishability (form sense):** ability to distinguish discontinuities or irregularities in object contours. This includes vernier acuity (ability to see two vertical lines placed one above the other as being displaced sideways).

Most acuity tests measure the size of the smallest pattern detail that can be discriminated, in minutes of arc of visual angle subtended at the eye. So that numerically higher acuity values will indicate better or sharper vision, visual acuity is usually expressed as decimal acuity, which is the reciprocal of the minutes of arc of visual angle subtended by the smallest discriminable detail. This definition of acuity applies to all of the four types of acuity listed above except minimum visibility, which uses as targets points of light or near approximations to points. While the critical target dimension could also be expressed in terms of linear extent at a specific distance or linear size on the retina, it is most convenient to express visual acuity in terms of visual angle since this permits direct comparison of acuity values for different types of acuity and between acuity values in different research reports. "Normal" visual acuity is widely taken to be 1.0 (i.e., a resolution of 1 min arc); however, the acuity of most young observers is closer to 0.9.

In measuring visual acuity, a large variety of objects and test patterns (targets), as well as observer tasks, have been used. Figure 1 shows some of the more common targets. In the figure, the distance S indicates the size of the critical detail used for acuity measurements. In cyclical targets, i.e., those with repetitive, regular elements, one cycle (C) is the distance between corresponding elements. Thus with a square-wave grating target (bar pattern), one cycle is one bar width plus one space, or the distance between bar centers. With cyclical targets, acuity is sometimes reported as **spatial frequency**, given as cycles/deg or cycles/min arc or cycles/mm at 250 mm. Targets containing bars yield visual acuities that vary with the number of bars and their length-to-width ratio. Table 1 lists conversions among different size units used to describe image dimensions.

With some acuity targets, such as discs, the task of the observer is to detect target presence. With patterns containing bars and with Landolt-C and E letters, the pattern is rotated from one presentation to the next and the observer must report target orientation. In still other tests, such as

Table 1. Conversion among units used to describe image dimensions.

You Have (A)	You Want (B)	Multiply (A) By
Degrees	Milliradians	17.453
Milliradians	Degrees	0.057296
Minutes of arc	Milliradians	0.29089
Milliradians	Minutes of arc	3.4377
mm subtended* at 250 mm	Milliradians	4.0000
mm subtended at 250 mm	Minutes of arc	13.751
Milliradians at 250 mm	mm subtended	0.25000
Minutes of arc at 250 mm	mm subtended	0.072722

*Subtended at the eye (or at a point of interest) by a flat surface at 90 deg to the line of sight.

Table 2. Visual acuity with different test patterns.

Test Target	Observer's Task	Acuity
Disc	Detect presence	30 sec arc
Square	Detect presence	14 sec arc
Line bar \geq 1 deg long	Detect presence	0.5 sec arc*
2 discs or 2 bars	See as two	25 sec arc
Tri-bar	See as three, detect orientation	70 sec arc
Gratings	Detect orientation or separation	35 sec arc/bar
E-letter chart	Detect orientation	1.4 x Snellen
Snellen letters	Read letters	0.8 min arc**
Checkerboard (4 squares)	Detect pattern	1 min arc
Landolt C (gapped ring)	Detect gap orientation	1.3 x Snellen
Vernier (displaced) lines	Detect displacement	2 sec arc

* The 0.5 sec of arc is for .99 detection probability

** Nominal value is 1.0 min arc.

NOTE: Acuity is for optimum viewing conditions. Acuity for E-chart and Landolt-C is better than for Snellen letters.

those using double discs or bars, the observer must discriminate the target as double rather than single.

Large differences between observers and between studies in visual acuity values occur as a result of differences in confidence in judgments (cautious judgment versus guessing), criteria of visibility or separation (clean or blurry separation, mere elongation of two discs, etc.), scoring methods, instructions, and training in judgment, as well as in viewing conditions (target contrast, illuminant spectrum and level, etc.). Some reports are based on only 1-3 observers unlikely to be average in vision. All of these factors influence measured acuity.

Acuity also varies with the type of acuity measured. Table 2 lists visual acuity for several different targets as measured under optimum or laboratory conditions, and also gives the observer's task with each. Under other conditions (field conditions), where contrast, illumination, and adaptation level are less favorable, and where vision is degraded by vibration and image motion, visual acuity will be worse. For example, outside visibility in an aircraft with a clean, unscratched, low-haze windscreen, facing away from the sun in very clear air on a sunny day with no buffeting, would probably be no better than 2 min arc for high-contrast Snellen letters. With poorer conditions, acuity could be much worse.

In clinical testing with letter charts, the observer is usually either 20 feet or 6 meters from the eye chart. Acuity is expressed as a ratio, such as 20/30 (termed Snellen acuity). Here, the ratio indicates that the tested person can barely read at 20 feet what a normal (or 20/20 vision) person can barely read at 30 feet. On such test charts, the letters are of standard size and shape. "Normal" or 20/20 vision is assumed to be the ability to resolve a target detail of 1 min arc at 20 ft. At this distance, the height and width of the smallest letters resolvable by a person with "normal" vision subtend 5 min arc, and letter stroke width is 1 min arc. Many young observers actually have a Snellen acuity closer to 20/15. Vision is usually tested at both far (20 ft or 6 m) and near (14 in. or 0.4 m) distances, for acuity at one distance, but not the other, may be satisfactory.

Letter charts, such as the Snellen chart, pose problems. For example, letters are not equally legible, and observers can memorize lines or parts of lines of letters or guess letters before they are clearly perceptible. E letter charts and Landolt-C tests randomly rotate the same pattern, eliminating letter legibility differences and memorization. Also, unlike tests using the Landolt C, results with Snellen letters are affected by **astigmatism**.

Correlation between visual acuities measured with dif-

ferent test patterns is low. For example, Snellen acuity is overestimated by checkerboards for acuity worse than 20/30, but underestimated for better vision. Snellen acuity is slightly underestimated at all acuity levels by Landolt-C tests. The nature of the visual task to be performed, therefore, should determine what type of visual acuity to measure and what target to use. The type of visual acuity measured by letter charts is most nearly related to minimum separability, as is that measured using two disc targets or bar patterns. With any of the more common measures of minimum separability, the obtained acuity value is limiting resolution for a high-contrast target. This is a one-number characterization which says nothing about the ability to discern the basic shape or form of objects. However, ability to discern low spatial frequencies, which is not measured by letter tests, is vital for shape discrimination and sometimes has important clinical implications. Low spatial frequencies convey the only information available at long viewing distances, during movement, or under low illumination. By measuring the contrast required for resolving the bars of a sine-wave grating at each of several spatial frequencies, an observer's contrast sensitivity function is obtained. This function reveals far more about visual ability than a one-number limiting resolution value. For normal observers, the peak of the function is at 2-5 cycles/deg of subtended angle (with the higher values reached at higher luminance levels); sensitivity falls off rapidly for higher and lower frequencies (CRefs. 1.632, 1.631). The range of variability for normal observers is at most ~ 0.25 log unit of contrast. Since the spatial frequencies of other acuity targets can be analyzed, visual acuity can be predicted from contrast sensitivity (CRef. 1.644).

The National Academy of Sciences has provided standards for testing acuity (Ref. 4). The test pattern specified is the Landolt C.

Constraints

• The presence of **astigmatism** affects acuity measurements made with many targets, such as lines, bar patterns, checkerboards, and letter charts, unless the orientation of the targets is varied.

• Visual acuity is influenced by viewing conditions (luminance level, viewing distance, exposure time, etc.) (CRef. 1.603).

Key References

1. Borish, T. M. (1970). *Clinical refraction* (3rd Ed.). Chicago: Professional Press.

2. Kelly, D. H. (1977). Visual contrast sensitivity. *Optica Acta*, 24, 107-129.

3. Farrell, R. J., & Booth, J. M. (1984). *Design handbook for imagery interpretation equipment*. Seattle, WA: Boeing Aerospace Co.

4. National Academy of Sciences (1980). Recommended standard procedures for the clinical meas-

urement and specification of visual acuity. Report of Working Group 39, Committee on Vision. *Advances in Ophthalmology*, 41, 103-148.

5. Riggs, L. A. (1965). Visual acuity. In C. H. Graham (Ed.), *Vision and visual perception*

(pp. 321-349). New York: Wiley.

6. Sloan, L. L., Rowland, W. M., & Altman, A. (1952). Comparison of three types of test target for the measurement of visual acuity. *Quarterly Review of Ophthalmology*, 8, 4-16.

Cross References

1.603 Factors affecting visual acuity;

1.631 Contrast sensitivity: effect of number of luminance modulation cycles and luminance level;

1.632 Contrast sensitivity: effect of luminance level (foveal vision);

1.644 Contrast sensitivity for Snellen letters

Notes

✓

✓

✓

✓

1.603 Factors Affecting Visual Acuity

Key Terms

Accommodation; age; contrast; contrast sensitivity; exposure duration; luminance; practice; pupil size; spatial resolution; target acquisition; target motion; viewing distance; visual acuity; visual field location; visual masking; wavelength

General Description

Visual acuity is the ability to resolve spatial detail. It is typically measured by presenting high-contrast patterns of various sizes at both far and near viewing distances. Decimal acuity is expressed as the reciprocal of the smallest pattern or pattern detail (in minutes of arc of visual angle) that can

be detected or identified at the given viewing distance (CRef. 1.602). The National Academy of Sciences has recommended testing standards for the measurement of visual acuity (Ref. 4). The accompanying table lists some of the factors known to affect acuity, the nature of the effect, and sources for further information.

Applications

Situations where target detectability or visual resolution must be maximized, or is to be measured.

- Interactions may occur among the various factors affecting acuity, but such interaction effects have not generally been studied.

Constraints

- Standard acuity measures provide information only about spatial perception of fine detail at high contrast. **Contrast sensitivity** is a more sensitive measure under low-contrast, low-spatial-frequency conditions.

Key References

1. Johnson, C. A. (1976). Effects of luminance and stimulus distance on accommodation and visual resolution. *Journal of the Optical Society of America*, 66, 138-142.

2. Kling, J., & Riggs, L. (Eds.) (1971). *Woodworth & Schlosberg's experimental psychology* (pp. 300-306). New York: Holt, Rinehart and Winston.

3. Leibowitz, H. (1952). The effect of pupil size on visual acuity for photometrically equated test fields at various levels of luminance. *Journal of the Optical Society of America*, 42, 416-422.

4. National Academy of Sciences. (1980). Recommended standard procedures for the clinical meas-

urement and specification of visual acuity. Report of Working Group 39, Committee on Vision. *Advances in Ophthalmology*, 41, 103-148.

5. Niven, J. I., & Brown, R. H. (1944). Visual resolution as a function of intensity and exposure time in the human fovea. *Journal of the Optical Society of America*, 34, 738-743.

6. Shlaer, S., Smith, E. L., & Chase, A. M. (1942). Visual acuity and illumination in different spectral regions. *Journal of General Physiology*, 25, 553-569.

7. Westheimer, G., & McKee, S. P. (1975). Visual acuity in the presence of retinal-image motion. *Journal of the Optical Society of America*, 65, 847-850.

Cross References

1.602 Measurement of visual acuity;

1.604 Visual acuity: effect of luminance level;

1.605 Visual acuity: effect of target and background luminance and contrast;

1.607 Vernier acuity and orientation sensitivity: effect of adjacent contours;

1.608 Two-dot vernier acuity: effect of dot separation;

1.610 Vernier acuity: offset discrimination between sequentially presented target segments;

1.611 Visual acuity: effect of target location in the visual field at photopic illumination levels;

1.612 Visual acuity: effect of target location in the visual field at scotopic illumination levels;

1.615 Visual acuity: effect of viewing distance;

1.616 Visual acuity: effect of viewing distance and luminance level;

1.617 Visual acuity with target motion: effects of target velocity and target versus observer movement;

1.618 Visual acuity with target motion: effect of target velocity and orientation;

1.619 Visual acuity with target motion: effect of direction of movement and luminance level;

1.620 Visual acuity with target motion: effect of direction of movement and target orientation;

1.621 Visual acuity with target motion: effect of anticipation time and exposure time;

1.622 Visual acuity with target motion: effects of practice;

1.623 Visual acuity and contrast sensitivity: effect of age;

1.644 Contrast sensitivity for Snellen letters;

1.645 Contrast sensitivity for a large population sample;

10.902 Acceleration of body rotation: effect on visual acuity;

Handbook of perception and human performance, Ch. 7, Sec. 4.

Factor	Effect on Acuity	References
Luminance level and contrast	<p>For dark targets on bright background, acuity improves as background luminance increases</p> <p>For light targets against dark background, acuity increases initially, then declines with increasing target intensity</p> <p>Acuity is greater at photopic (high) than at scotopic (<0.03 cd/m²) illumination levels</p>	CRefs. 1.604, 1.605, 1.612, 1.616 Ref. 2
Spectral composition (color) of illumination	<p>For some acuity tasks (minimum visibility, vernier acuity), acuity is better under narrow-band than wideband illumination</p> <p>With narrow-band illumination and moderate pupil size (2-5 mm), wavelength has no effect on acuity provided illumination level is high enough or compensation is made for relative spectral sensitivity</p>	Ref. 6
Retinal location (distance from point of fixation)	<p>At photopic illumination levels, acuity rapidly decreases as target is displaced toward periphery of visual field</p> <p>At scotopic illumination levels, acuity is greatest when target is offset ~4 deg from fixation; acuity declines as distance increases</p>	CRef. 1.611 CRef. 1.612
Viewing distance	Acuity decreases at greater viewing distances, especially at high spatial frequencies	Ref. 1; CRefs. 1.615, 1.616
Accommodation (eye focus)	Acuity improves with reduction of accommodation errors by corrective lenses	Ref. 1
Exposure time	<p>For targets at photopic luminance levels, acuity improves with increase in duration up to 0.1-0.2 sec, but then levels off</p> <p>Below critical duration of 0.1-0.2 sec, exposure duration trades off with target intensity so that target detectability remains constant provided that total light energy (duration × luminance) remains constant</p>	Ref. 2 Ref. 5
Target motion	<p>Acuity decreases as target velocity increases, especially for very rapid target movement (≥ 20 deg/sec)</p> <p>Some investigators have found acuity to be the same for static and moving targets for target velocities of <2.5 deg/sec with vertical and horizontal target motion and velocities <1 deg/sec with oblique movement</p>	CRefs. 1.617, 1.618, 1.619, 1.620, 1.621
Onset asynchrony of test elements	Acuity decreases as time between onsets of top and bottom lines of vernier acuity target increases	CRef. 1.610
Vertical separation of test elements	Acuity is greatest when vertical separation between the elements of a vernier acuity target is 2-6 min arc of visual angle	CRef. 1.608
Masking by adjacent contours	Vernier acuity declines when the acuity target is flanked by masking lines	CRef. 1.607
Pupil size	Acuity is highest at intermediate pupil diameters (2-5 mm), but is reduced at very small and very large pupil sizes	Ref. 3
Age	Acuity reaches adult levels at ~5 years, and declines beyond 20s for intermediate and high spatial frequencies	CRef. 1.623
Assessment method	Acuity varies somewhat with visual task and target display used (e.g., Snellen letters, Landolt C)	CRef. 1.602
Acceleration	Acuity is degraded when the observer is subjected to accelerative forces	CRef. 10.902

1.604 Visual Acuity: Effect of Luminance Level

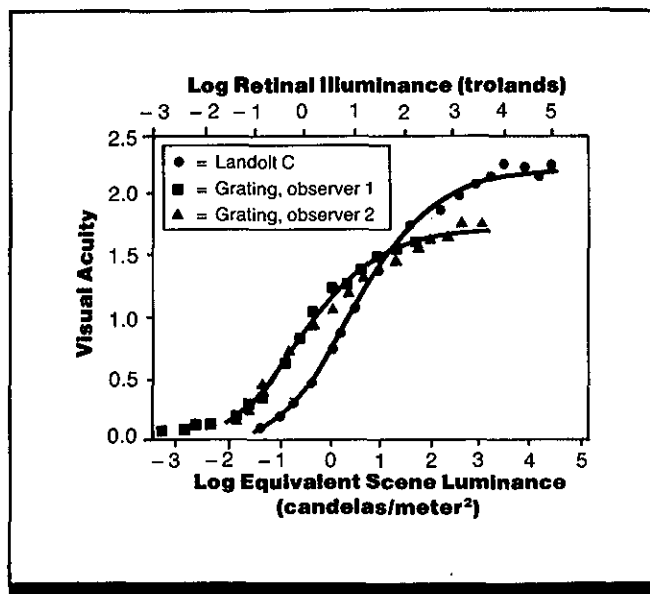

Figure 1. Visual acuity as a function of background luminance measured with a Landolt-C target (1 observer) and square-wave grating (2 observers). Data are averages across one observation at each of four orientations; observers dark-adapted for 20 min. (From Ref. 4)

Key Terms

Contrast; luminance; spatial resolution; target acquisition; visual acuity

General Description

Visual acuity is measured using a wide variety of test targets. However measured, acuity increases as background or mean luminance level increases. Depending on the type of test target, acuity approaches an asymptote between 40 and 1000 cd/m².

Applications

Measurement of visual acuity; situations in which visual resolution of fine detail must be maximized.

Methods (across studies)

Test Conditions

- Landolt-C targets; sine-wave and square-wave gratings (bar patterns), 0.9-50 cycles/deg
- 2-4 deg target fields and 12-30 deg surrounds

- Background or mean retinal luminance range 0.0003-318 cd/m² (0.001-1000 td)
- Monocular viewing; artificial pupil 2-2.4 mm in diameter; targets for Fig. 1 presented in Maxwellian view

Experimental Procedure

- Method of adjustment
- Independent variables: retinal illumination, spatial frequency of gratings, size of Landolt-C, contrast, exposure duration
- Dependent variables: visual (decimal) acuity, defined as the reciprocal of the smallest resolvable bar width (one-half the highest

- resolvable spatial frequency) or smallest resolvable gap in Landolt-C pattern, in minutes of arc of visual angle
- Observer's task: to increase size or contrast of gratings until resolvable, or to increase size of Landolt-C until orientation of gap is resolvable
- 2-3 observers for each target

Experimental Results

- Visual acuity measured in terms of minimum resolvable bar width of grating patterns or minimum resolvable gap in Landolt-C targets improves with increasing luminance.
- Acuity approaches an asymptote at a luminance of 40-1000 cd/m², depending on the type of target used.
- At a given luminance level, acuity increases as target contrast or target exposure duration increases (data not shown).

Variability

There was close agreement between the acuities of the 2 observers tested with the grating patterns.

Repeatability/Comparison with Other Studies

Comparable results have been obtained using a vernier-alignment task to measure acuity (Ref. 1).

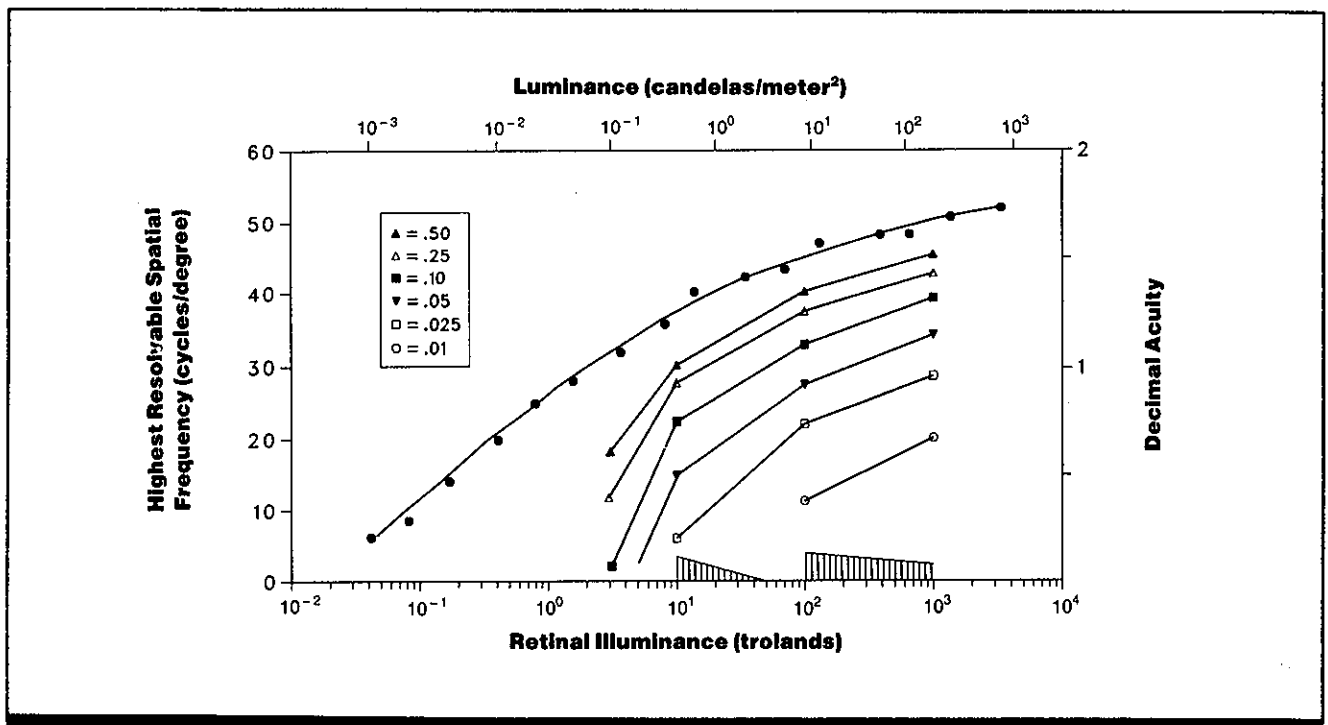

Figure 2. Visual acuity for bar patterns as a function of mean luminance. A spatial frequency of 1 cycle/deg is twice the width of a single bar in the bar pattern. The filled circles show acuity for a square-wave grating with a contrast of 1.0 for one observer from Fig. 1. The six other curves show sine-wave grating acuity for the contrasts noted in the legend, replotted from data in Ref. 3. The hatched areas represent low spatial frequencies that could not be resolved at the two lowest contrast levels. The values for luminance on the top axis represented free viewing (without an artificial pupil); they were calculated using the values in Table 15 of Ref. 2 (rather than converted from trolands by the standard formula using pupil area). (From *Handbook of perception and human performance*)

Constraints

- Visual acuity is affected by many factors, including location in the field of view, viewing distance, and pupil size. These factors must be considered in applying results under other conditions (CRef. 1.603).

Key References

1. Baker, K. E. (1948). Some variables influencing vernier acuity. I. Illumination and exposure time. II. Wave-length and illumination.

Journal of the Optical Society of America, 39, 567-576.

2. LeGrand, Y. (1968). *Light, color, and vision* (2nd Ed.). London: Chapman and Hall.

*3. Patel, A. S. (1966). Spatial resolution by the human visual system. The effect of mean retinal illuminance. *Journal of the Optical Society of America*, 56, 689-693.

*4. Shlaer, S. (1937). The relation between visual acuity and illumination. *Journal of General Physiology*, 21, 165-188.

Cross References

1.603 Factors affecting visual acuity;

1.605 Visual acuity: effect of target and background luminance and contrast;

1.611 Visual acuity: effect of target location in the visual field at photopic illumination levels;

1.612 Visual acuity: effect of target location in the visual field at scotopic illumination levels;

1.613 Visual acuity: effect of exposure time;

1.616 Visual acuity: effect of viewing distance and luminance level

1.605 Visual Acuity: Effect of Target and Background Luminance and Contrast

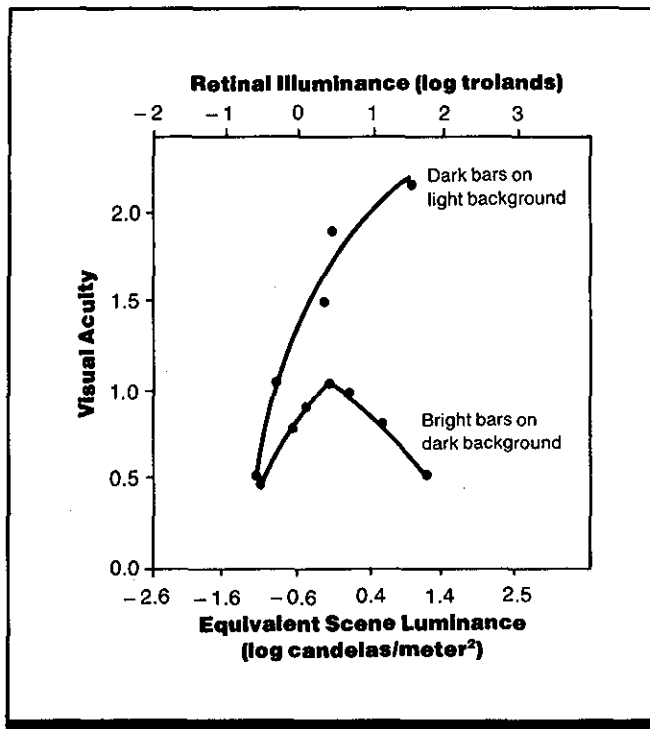

Figure 1. Visual acuity as a function of intensity for parallel bar targets. Horizontal axis shows target luminance for light bars on dark background and background luminance for dark bars on light background. Acuity is equal to 1 divided by resolution threshold in min arc of visual angle; normal acuity = 1.0 (i.e., threshold of 1 min arc). (From Ref. 2, based on data from Ref. 6)

Key Terms

Contrast; luminance; spatial resolution; target acquisition; visual acuity

General Description

For dark bars against a light background, visual acuity improves continuously as background illumination increases. For light bars against a dark background, acuity first increases as bar intensity rises, but then declines. Visual acuity thus depends not only on target intensity but also on how light is distributed between the target and the background.

Methods

Test Conditions

- Target was virtual image of two parallel, vertical bars; image of each bar subtended 2 min 22 sec (width) × 20 min (height); variable distance between bars; targets produced by reflection from polished metal bars

- Background field 70 × 20 min, produced by reflection of a separate source from large mirror behind target bars
- Target dark while luminance of background varied, or background dark while luminance of target varied
- Monocular viewing through artificial pupil (4 mm²); 33-cm viewing distance

Experimental Procedure

- Method of adjustment
- Independent variables: luminance of target, luminance of background, target-background contrast
- Dependent variable: visual acuity, measured in terms of visual angle subtended by minimum perceivable bar separation

- Observer's task: judge when separation between bars first becomes visible (i.e., two bars perceived instead of one)
- Observers dark adapted prior to each set of measurements
- 2 observers, with extensive practice

Experimental Results

- For light bars on a dark background, acuity is low at low intensities. As the intensity of the bars increases, acuity rises, reaching a peak of slightly over 1.0 at a log luminance of approximately -0.2 cd/m^2 ; as the intensity elevates further, however, acuity declines to its original level.
- For dark bars against a light background, acuity increases steadily as the intensity of the background rises, although the rate of increase declines progressively.

Constraints

- The exact moment when the observer sees two bars instead of one is difficult to identify precisely; other acuity tasks may provide more precise resolution measures (Ref. 1.602).
- Results may not hold under conditions where both target and background are bright.

Key References

1. Baker, K. E. (1949). Some variables influencing vernier acuity. *Journal of the Optical Society of America*, 39, 567-576.
2. Bartley, S. H. (1941). *Vision: A study of its basis*. New York: Van Nostrand.

3. Craik, K. J. W. (1939). The effect of adaptation on visual acuity. *British Journal of Psychology*, 29, 252-266.
4. Patel, A. S. (1966). Spatial resolution by the human visual system. The effect of mean retinal luminance. *Journal of the Optical Society of America*, 56, 689-694.

Variability

Thresholds are high and variable for unpracticed observers.

Repeatability/Comparison with Other Studies

Other studies have also found acuity to improve as background luminance increases for dark targets on light backgrounds (Refs. 1, 3, 5). Acuity for bar pattern (grating) targets also improves as mean luminance of the pattern increases (Refs. 4, 5).

- **Contrast sensitivity** has been found to be a more sensitive measure of visual ability under low contrast conditions.
- Visual acuity is influenced by a number of factors (such as luminance level, viewing distance, and exposure time) which must be considered in applying these results under different conditions (CRef. 1.603).

Cross References

- 1.602 Measurement of visual acuity;
- 1.603 Factors affecting visual acuity;
- 1.607 Vernier acuity and orientation sensitivity: effect of adjacent contours

5. Shlaer, S. (1937). The relation between visual acuity and illumination. *Journal of General Physiology*, 21, 165-188.
- *6. Wilcox, W. W. (1932). The basis of the dependence of visual acuity on illumination. *Proceedings of the National Academy of Science*, 18, 47-56.

1.606 Visual Acuity: Effect of Illuminant Wavelength

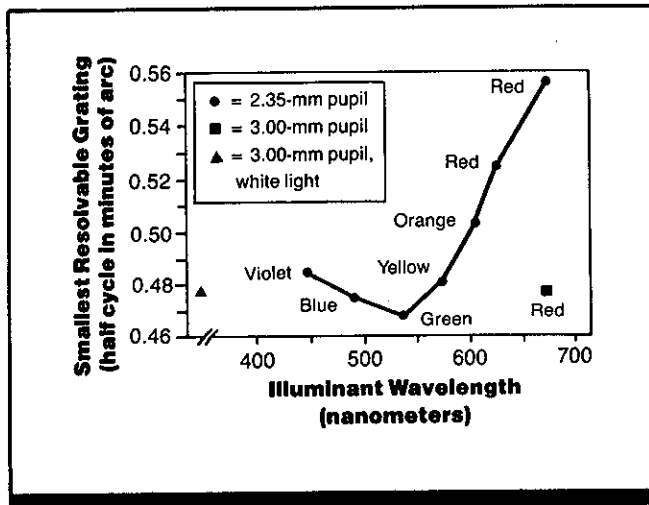

Figure 1. The relationship between illuminant wavelength and the width of a single bar of the smallest resolvable grating. The function is the inverse of visual acuity, which equals the reciprocal of the smallest resolvable detail in minutes of arc of visual angle; for example, acuity would be poorest with illumination in the red range. (From Ref. 5)

Key Terms

Color; spatial resolution; target acquisition; visual acuity; wavelength

General Description

When targets are viewed through a small artificial pupil, visual acuity (visual resolution of bar patterns) is best with illuminant wavelengths in the green range (~535 nm). Acuity is generally poorer at shorter and longer wave-

lengths. This decrease is primarily due to diffraction effects at the pupil; it does not occur when targets are viewed through a larger pupil. With a grating-resolution task, white light produces nearly as good visual performance as narrow spectral band illuminants.

Applications

Measurement of acuity; situations in which visual resolution of small detail must be maximized.

Methods

Test Conditions

- Square-wave grating (bar pattern), bar widths (half-cycle) from 0.47-0.56 min arc of visual angle
- Grating presented at fixed distance of 1 m in center of a uniform field 30 deg in diameter
- Grating projected through narrow-band filters with dominant wavelengths of 670 nm (red), 625 nm (red), 605 nm (orange),

575 nm (yellow), 535 nm (green), 490 nm (blue), 450 nm (violet), and white light

- Artificial pupil either 2.35 or 3.00 mm in diameter; monocular viewing with right eye
- Background luminance varied in each wavelength condition to obtain maximum performance
- Observers completely **dark adapted**, and then visual acuity determined after adaptation to field brightness

Experimental Procedure

- Independent variables: width of grating bars; illuminant wavelength, measured in nm
- Dependent variable: visual acuity, defined as the width of an individual bar in the smallest resolvable grating (i.e., one-half cycle of the grating)
- Observer's task: report smallest resolvable test grating
- 2 observers with extensive practice

Experimental Results

- Visual acuity for square-wave gratings is best when they are illuminated by light in the green range (535 nm). At longer wavelengths, acuity falls off rapidly with a 2.35-mm pupil, but is near or at maximum with a 3.00-mm pupil. This implies that the loss in acuity at longer wavelengths is due partly to diffraction effects at the pupil (CRef. 1.614). **Chromatic aberration** also plays a large part.
- Visual acuity is nearly as good with white light as with light of narrower spectral distributions for grating test patterns.

Constraints

- Results reported apply only to visual acuity when illumination is so high that luminance level is no longer a factor.
- Visual acuity is influenced by a number of factors (such as luminance level, viewing distance, and exposure time) which must be considered in applying these results under different conditions (CRef. 1.603).

Key References

- | | | | |
|---|--|--|---|
| <p>1. Baker, K. E. (1949). Some variables affecting vernier acuity. I. Illumination and exposure time. II. Wavelength of illumination. <i>Journal of the Optical Society of America</i>, 39, 567-576.</p> | <p>2. Olzak, L. A., & Thomas, J. P. (1986). Seeing spatial patterns. In K. R. Boff, L. Kaufman, & J. P. Thomas (Eds.), <i>Handbook of perception and human performance: Vol. 1. Sensory processes and perception</i>. New York: Wiley.</p> | <p>3. Schober, H., & Wittman, K. (1938). Untersuchungen über die Sehscharfe bei verschieden für bigen Licht. <i>Das Licht: Z praktische Leucht-u. Beleuchtungs-Aufgab</i>, 8, 199-201.</p> | <p>4. Schlaer, S. (1937). The relation between visual acuity and illumination. <i>Journal of General Physiology</i>, 21, 165-188.</p> <p>*5. Schlaer, S., Smith, E. L., & Chase, A. M. (1941). Visual acuity and illumination in different spectral regions. <i>Journal of General Physiology</i>, 25, 553-569.</p> |
|---|--|--|---|

Cross References

- 1.603 Factors affecting visual acuity;
- 1.614 Visual acuity: effect of pupil size

Variability

No information on variability was given.

Repeatability/Comparison with Other Studies

The results reported here are consistent with earlier work on the effect of illuminant wavelength on visual acuity, intensity discrimination, flicker, and dark adaptation (Ref. 1). Visual acuity under short-wavelength (blue) light improves when pupil size is made artificially small (1 mm) (Ref. 2). Other investigators have found that acuity as measured by **minimum visibility**, vernier offset resolution, and **Landolt-C** patterns is better in narrow-band light than in white light (Refs. 1, 3, 5).

1.607 Vernier Acuity and Orientation Sensitivity: Effect of Adjacent Contours

Key Terms

Hyperacuity; spatial orientation sensitivity; spatial resolution; vernier acuity; vernier offset discrimination; vertical misalignment; visual acuity; visual masking

General Description

The presence of **masking** lines interferes both with the judgment of inclination (i.e., rotation) from vertical of a stationary target centerline and with the detection of misalignment direction of two line segments. Although inclination threshold is more affected by interference than is misalignment threshold, the target-mask separations for maximum masking are quite similar: 2 min arc of visual angle for inclination and 3.5 min arc for misalignment (distances are between target and flanking line on each side).

Applications

Measurement of acuity; situations in which visual resolution of small detail must be maximized.

Methods

Test Conditions

Study 1 (Ref. 1)

- A single vertical or inclined (i.e., rotated from vertical) line, 30 min arc long by 15 sec arc wide, flanked on each side by a vertical masking line 15 min arc long (Fig. 1a); displayed on CRT with a luminance of ~ 160 cd/m²
- 0.2-sec stimulus presentations to center of visual field with 3-sec interval between onsets of successive stimuli
- Distance between target line and each masking line varied from 0-10 min arc; target also presented without masking lines
- Dark background; viewing distance 6.8 m; observation was usually binocular

Study 2 (Ref. 2)

- Vernier target consisting of two vertical lines, each 6.4 min arc long, with the abutting ends slightly offset horizontally; lines flanked on each side by a masking vertical line (3.2 min arc long) centered at offset between lines (Fig. 1b); target displayed on a CRT with a luminance of ~ 320 cd/m²
- Distance of center target line from each masking line varied from 0-7 min arc
- Dark background; viewing dis-

tance 4 or 6 m; binocular observation

- 0.05-sec stimulus presentations to center of visual field with 3-sec interval between onsets of successive stimuli

Experimental Procedure

Study 1

- Method of constant stimuli
- Independent variable: distance between target and mask in min arc
- Dependent variable: inclination threshold, defined as magnitude of inclination from vertical (in min arc) with direction of inclination correctly identified on 75% of trials
- Observer's task: judge whether the target line was inclined clockwise or counterclockwise from vertical; error feedback provided
- 2 observers with extensive practice

Study 2

- Method of constant stimuli
- Independent variable: distance between center of vernier target and each mask, in min arc
- Dependent variable: magnitude of misalignment, in sec arc, with direction of offset correctly judged on 75% of the trials
- Observer's task: judge whether the top line was to the left or to the right of the bottom line; error feedback provided
- 1 observer with extensive practice

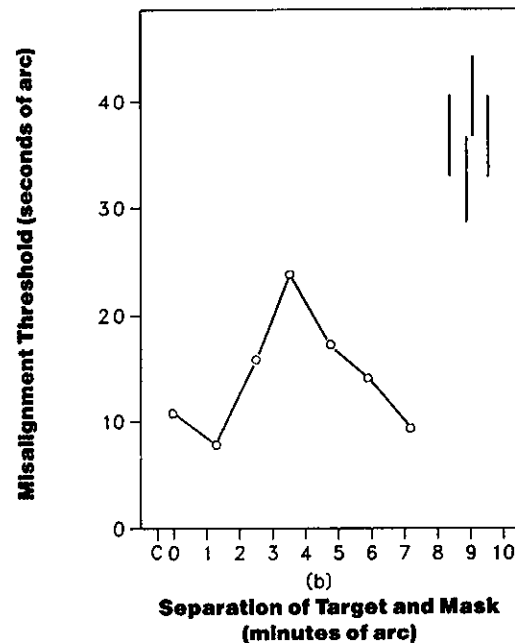
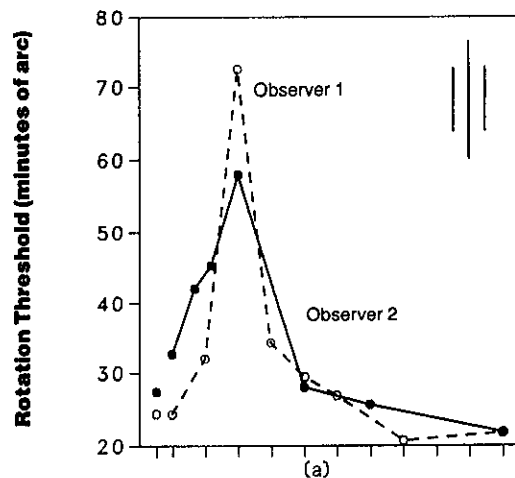

Figure 1. (a) Threshold for inclination (i.e., rotation from vertical) of centerline with two vertical flanking lines (Study 1). (From Ref. 1) (b) Misalignment threshold in sec arc of visual angle as a function of separation of target and masking lines (Study 2). The stimulus configurations are shown in the inset; target is central line or lines, flanking lines are masks. Each curve is for an individual observer. The data points in panel (a) identified by C on the x-axis are for the no mask condition. (From Ref. 2)

Experimental Results

- For judgments of the direction of inclination from vertical of a line, inclination threshold is between 20-30 min arc when no flanking lines are present as masks. The threshold is higher when masking lines are present and each line is closer than 4-6 min to the target line (Fig. 1a). Maximum masking occurs when each masking line is ~2 min from the target line.
- For judgments of the direction of misalignment of a ver-

nier target (e.g., two vertical lines) with flanking lines present as masks, maximum masking occurs when each flanking line is 3.5 min arc from the center of the vernier target (Fig. 1b).

Variability

- Within-observer standard error is 10-15% for Study 1 and 10% for Study 2. The data for the 2 observers in Study 1 were very similar (Fig. 1a).

Constraints

- Effect of masking on inclination threshold is different for masks of varying length, number, and orientation (CRef. 1.609).
- For vernier judgments, horizontal masking lines have

somewhat different effects than vertical masking lines (CRef. 1.652).

- Visual acuity is influenced by a number of factors (such as luminance level, viewing distance, and exposure time) which must be considered in applying these results under different conditions (CRef. 1.603).

Key References

*1. Westheimer, G., Shimamura, K., & McKee, S. P. (1976). Interference with line-orientation sensitivity. *Journal of The Optical Society of America*, 66, 332-337.

*2. Westheimer, G., & Hauske, G. (1975). Temporal and spatial interference with vernier acuity. *Vision Research*, 15, 1137-1141.

Cross References

1.602 Measurement of visual acuity;
1.603 Factors affecting visual acuity;

1.608 Two-dot vernier acuity: effect of dot separation;
1.609 Visual acuity: difference thresholds for spatial separation;

1.610 Vernier acuity: offset discrimination between sequentially presented target segments;
1.652 Orientation-selective effects on contrast sensitivity;

5.805 Illusions of perceived tilt; *Handbook of perception and human performance*, Ch. 7, Sec. 3.1

1.608 Two-Dot Vernier Acuity: Effect of Dot Separation

Key Terms

Hyperacuity; onset asynchrony; spatial resolution; vernier acuity; vernier offset discrimination; vertical misalignment; visual acuity

General Description

Detection of vertical misalignment of two small targets is optimal (i.e., threshold is lowest) when the vertical separation of the target is between 2 and 6 min arc of visual angle. Both larger and smaller separations yield higher thresholds.

Applications

Measurement of visual acuity; situations in which visual resolution of small detail must be maximized.

Methods**Test Conditions****Study 1 (Ref. 1)**

- Two squares, one above the other, each side 1 min arc long, displayed on CRT; luminance of 159 cd/m²
- Vertical separation of squares 2-14 min arc
- Targets presented for 0.5 sec every 3 sec to the center of the visual field (fovea)
- Dark background; viewing distance 6.8 m; binocular observation with natural pupils; observer's head in head rest

Study 2 (Ref. 2)

- Two dots, one above the other, each a fraction of 1 min arc wide and 30 sec long, displayed on CRT; luminance 60-73 cd/m²
- Vertical separation of dots 1-13 min arc
- Targets presented for 0.2 sec every 3 sec to the center of the visual field (fovea)

- Dark background; viewing distance 6.8 m; binocular observation with natural pupils

Experimental Procedure**Study 1**

- Method of constant stimuli
- Independent variable: degree of vertical separation of the two squares
- Dependent variables: misalignment threshold, defined as minimum amount of misalignment of squares that yields correct judgments 75% of the time
- Observer's task: judge whether the top square was to the right or to the left of the bottom square
- 2 observers with extensive practice

Study 2

- Method of constant stimuli; feedback usually given
- Independent variable: degree of vertical separation of the two dots
- Dependent variable: misalignment threshold, defined as minimum amount of misalignment of dots that yields correct judgments 50% of the time
- Observer's task: judge whether the upper dot was to the right or to the left of the lower dot
- 2 observers with extensive practice

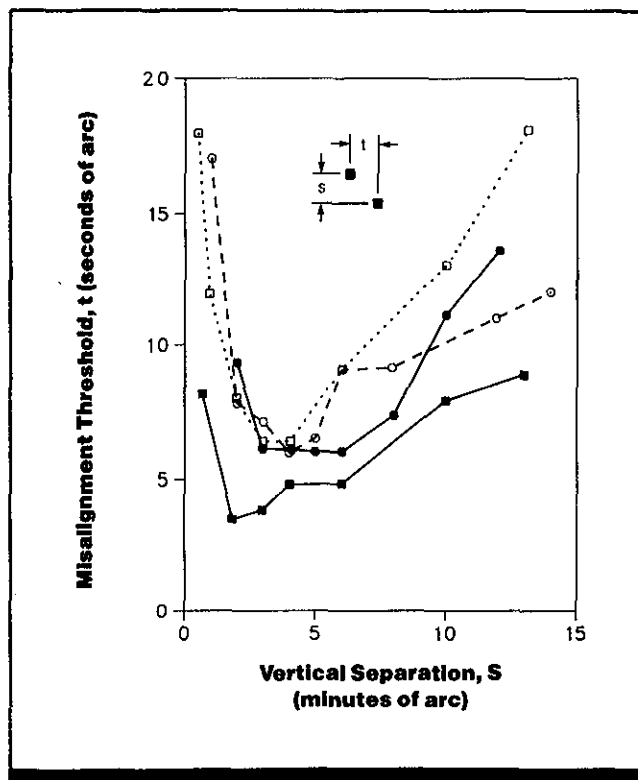

Figure 1. Two-target vernier acuity as a function of target separation. Smallest detectable misalignment (t in inset) is shown for different angular distances (s) between targets. Filled and open circles are data from Study 1 (Ref. 1); filled and open squares are data from Study 2 (Ref. 2). Note that vertical separation is measured in min of arc, whereas threshold misalignment is measured in sec of arc. (From *Handbook of perception and human performance*)

Experimental Results

- Misalignment threshold for small targets is a U-shaped function of the vertical separation between the targets. The misalignment threshold is at its lowest (3-6 sec arc) for vertical separations between 2-6 min arc.
- The optimal separation of the two targets (i.e., the separation yielding the lowest threshold) is not greatly different over a wide range of mid to high luminance levels and is relatively unaffected by target shape (square versus dot) and small differences in target duration.

Variability

- Within-observer standard error of the mean is 10-25% of

threshold value. Optimal separation of dots for lowest thresholds varies somewhat across observers.

threshold value. Optimal separation of dots for lowest thresholds varies somewhat across observers.

Repeatability/Comparison with Other Studies

The typical study of vernier acuity uses two misaligned vertical lines rather than two dots. A second experiment in Study 2 found that the misalignment threshold did not increase for vertical separations smaller than 2-4 min arc for lines at least 4 min arc long. Thus, the misalignment threshold as a function of vertical separation is monotonically increasing, not U-shaped, for lines at least 4 min arc long. Other studies show that the optimal separation of targets is different for locations 2.5 deg or greater from the fovea.

Constraints

- Values obtained do not hold for targets with orientations different from vertical, or for moving targets.
- Visual acuity is influenced by a number of factors (such as luminance level, viewing distance, and exposure time) which must be considered in applying these results under different conditions (CRef. 1.603).

Key References

*1. Westheimer, G. (1982). The spatial grain of the perifoveal visual field. *Vision Research*, 22, 157-162.

*2. Westheimer, G., & McKee, S. P. (1977). Spatial configurations for visual hyperacuity. *Vision Research*, 17, 941-947.

Cross References

1.602 Measurement of visual acuity;

1.603 Factors affecting visual acuity;

1.607 Vernier acuity and orientation sensitivity: effect of adjacent contours;

1.609 Visual acuity: difference thresholds for spatial separation;

1.610 Vernier acuity: offset discrimination between sequentially presented target segments;

Handbook of perception and human performance, Ch. 7, Sect. 3.1

1.609 Visual Acuity: Difference Thresholds for Spatial Separation

Key Terms

Gap discrimination; hyperacuity; pattern resolution; spatial separation; visual acuity

General Description

When presented with a pair of parallel vertical lines with a small space between them, observers can judge quite accurately (within seconds of visual angle) whether the space is wider or narrower than a reference separation. In such spatial discrimination tasks, discrimination is best for reference separations of 1-8 min of visual angle. Visual acuity for spatial separation is as good as discrimination for lateral displacement of lines (vernier acuity).

Applications

Displays or environments requiring visual resolution of fine detail; possible basis for a sensitive diagnostic vision test that measures visual abilities differently than standard visual acuity tests (Ref. 1).

Methods

Test Conditions

Study 1 (Ref. 2)

- Pairs of bright (~ 300 cd/m²), vertical parallel lines, < 1 min arc of visual angle wide, 12.8 min arc high, viewed against dimmer background
- Separation of lines varied; reference separation presented several times in "acquaintance" period before start of test session but not shown during test trials; test separation varied and was 0, 6, 12, or 18 sec arc more or less than reference separation
- Targets displayed on CRT with eye fixation markers on screen
- Test lines displayed every 3 sec, with 200 msec presentation duration
- Viewing distance not given

Study 2 (Ref. 1)

- Pairs of vertical parallel lines, 30 min arc long

- Reference separations of 4-14 min arc; test separations varied about reference separation; reference separation not present for comparison when test separations viewed; reference separation presumably presented for viewing before beginning of test trials
- 500-msec presentation duration
- No other details given on target or viewing conditions; conditions probably similar to Study 1

Experimental Procedure

Study 1

- Method of constant stimuli
- Independent variable: test separation between parallel vertical lines
- Dependent variable: discrimination threshold for line separation, defined as the separation at which responses were 75% correct
- Observer's task: judge whether the distance between the test lines

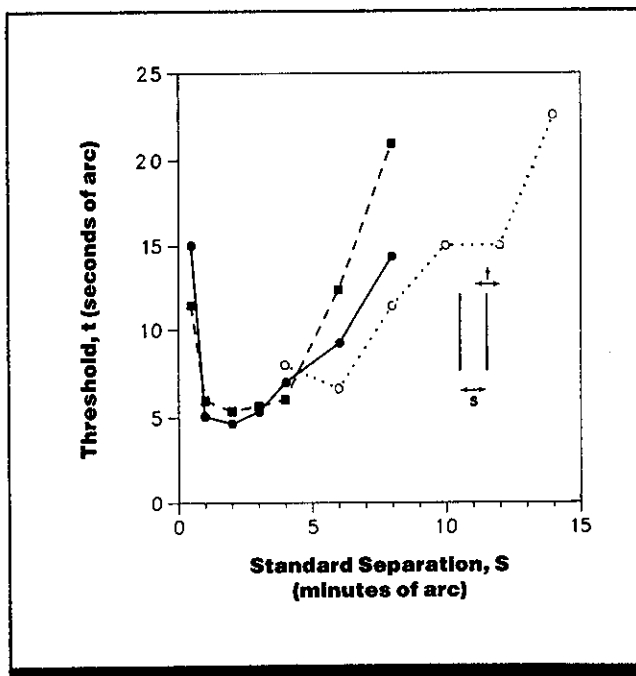

Figure 1. Discrimination of spatial separation. Ordinate shows the smallest difference between the spatial separation of two vertical test lines and the separation of two reference lines that could be reliably discriminated as a function of the separation of the reference lines (standard separation). Each curve represents the mean threshold values for a single observer. Filled symbols are data from Study 1; open symbols are data from Study 2. (From *Handbook of perception and human performance*)

is wider or narrower than the reference separation; error feedback provided

- At least 2 observers with normal visual acuity and extensive practice

Study 2

- Method of constant stimuli
- Independent variable: test separation between parallel vertical lines
- Dependent variable: discrimina-

tion threshold for line separation, defined as the separation at which responses were 75% correct

- Observer's task: judge whether the distance between the test lines is wider or narrower than the reference separation; error feedback probably provided
- 1 observer with extensive practice

Experimental Results

- Difference thresholds for spatial separation of lines is lowest (sensitivity is greatest) when the reference separation is ~ 1 -8 min of visual angle.
- Difference threshold increases for spatial separations smaller or larger than this range, resulting in a U-shaped threshold curve.
- This spatial resolution is termed *hyperacuity* because the resolution limit (5-7 sec arc at optimal reference separations) is less than the diameter of cones in the retina.

Variability

In Study 1, standard errors of the mean ranged from ~ 0.60 -4.4 sec arc; standard errors were higher for the smallest and largest reference separations than for mid-range separations. Standard errors of the mean for Study 2 range from < 1 sec of visual angle at 6 min of separation to ~ 2.5 sec at 14 min of separation.

Repeatability/Comparison with Other Studies

Results are comparable to those reported for discrimination of spatial separations defined by dark lines on bright background, dots, edges, an edge and a line, and bars (controlled for average brightness).

Constraints

- A number of factors including practice, target line length, target location in the visual field, and the presence of nearby targets are known to affect acuity and must be considered in applying these data under other conditions (CRef. 1.603).

Key References

*1. Westheimer, G. (1979). The spatial sense of the eye. *Investigative Ophthalmology and Visual Science*, 18, 893-912.

*2. Westheimer, G., & McKee, S. P. (1977). Spatial configurations for visual hyperacuity. *Vision Research*, 17, 941-947.

Cross References

1.603 Factors affecting visual acuity;

1.608 Two-dot vernier acuity: ef-

fect of dot separation;

Handbook of perception and human performance, Ch. 7, Sect. 3.1

1.610 Vernier Acuity: Offset Discrimination Between Sequentially Presented Target Segments

Key Terms

Eye movements; spatial resolution; vernier acuity; vernier offset discrimination; vertical misalignment; visual acuity

General Description

Discrimination of vernier offset between two consecutively presented vertical lines deteriorates as the time between their onsets increases. Both threshold acuity (smallest detectable offset) and point of subjective equality (PSE, offset at which targets appear aligned) increase monotonically as the interval between presentation of upper and lower lines increases. Errors are attributed to displacements caused by involuntary eye movements (CRef. 1.911) and deterioration of memory for spatial location.

Applications

Measurement of acuity; situations in which visual resolution of small detail must be maximized.

Methods

Test Conditions

- Two vertical lines, 34 min 20 sec × 1 min 5 sec of visual angle, placed one above the other with 2 min 20 sec vertical separation
- Lines displaced from one another horizontally; two horizontal offsets chosen to span each observer's range of certainty
- Dark room; viewing distance 2.44 m (8 ft); **monocular** viewing; stabilized head; vertical lines presented by light from separate lamps shown through two vertical slits
- Trial began with 4-sec fixation on 3.5-min circular target, followed by 400-msec dark interval, followed by 2-msec presentation of lower line, followed by dark interval (200 μsec, 50, 100, 200, 300, 500, or 800 msec), followed by 2-msec presentation of upper bar
- Horizontal eye movements continuously monitored by contact lens technique (CRef. 1.904)

Experimental Procedure

- Method of constant stimuli; two-alternative forced-choice procedure
- Independent variables: duration of interval separating presentations of upper and lower lines; horizontal offset between upper and lower lines; **retinal image offset**, calculated by adding vernier offset of lines to horizontal distance moved by eye during dark interval
- Dependent variables: vernier acuity threshold and PSE, calculated by probit analysis as, respectively, the standard deviation and median of the psychometric function plotting percent of "to the right" reports versus vernier offset
- Observer's task: judge whether upper line appeared to the left or right of the lower line
- ~200 trials per each dark interval for each observer
- 2 highly practiced observers

Experimental Results

- The threshold for detecting an offset between the upper and lower target lines (vernier offset) increases monotonically with increasing interval between presentation of the two lines (Fig. 1a, solid lines). PSE shifts to the left (i.e., targets appear aligned when top target is to the left of lower target) with increasing interval length (Fig. 1b, solid line).
- Threshold and PSE are also plotted as a function of retinal offset, the horizontal offset between the retinal position of the upper and lower lines (dashed lines in Figs. 1a, 1b). Retinal offset differs from actual offset because involuntary eye movements add to the retinal offset of the two lines.

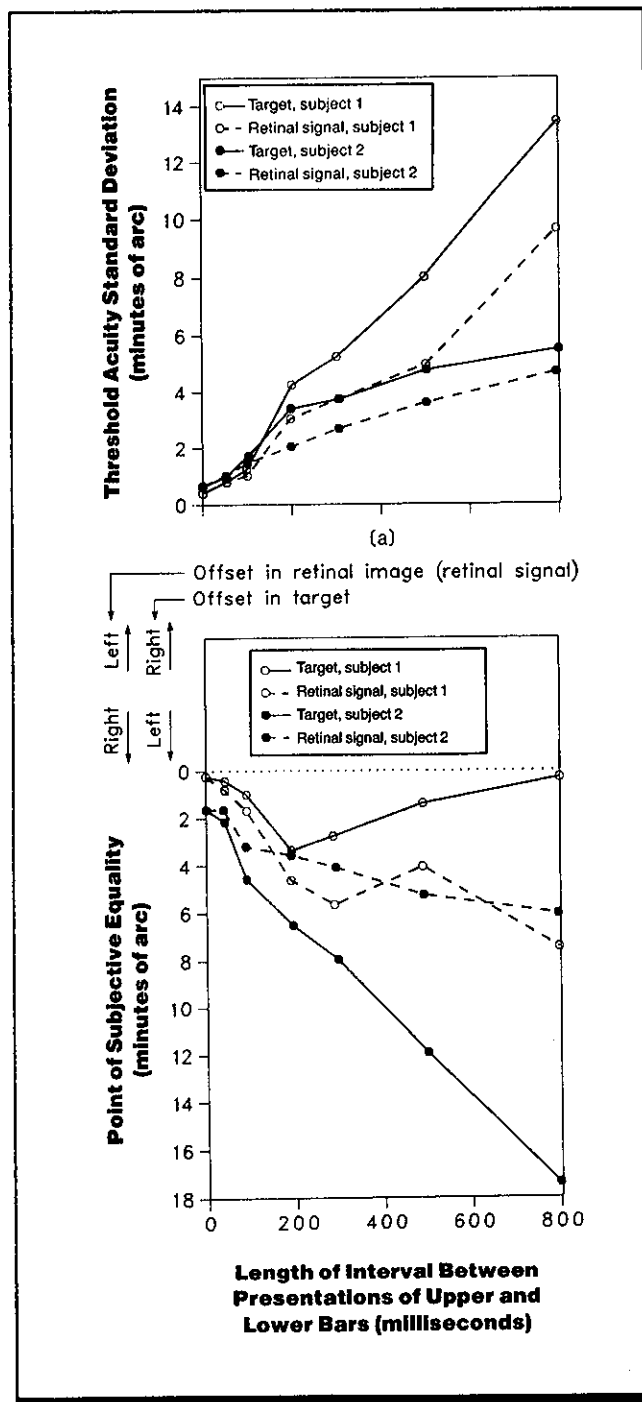

Figure 1. Vernier acuity with variable time interval between presentation of the two top and bottom target lines. (a) presents threshold acuity or smallest detectable offset (measured as the standard deviation of offset judgments); (b) shows point of subjective equality or offset at which lines appeared aligned (median of offset judgments), where zero indicates no offset. Solid lines indicate measurements of the offset of the actual target display and dashed lines indicate measurements of retinal offset, which takes into account additional retinal offset due to eye movements. (From Ref. 5)

- The deterioration in vernier offset acuity with increasing interval between top and bottom line presentations is attributed to (1) involuntary eye movements which increase the retinal offset of the lines and (2) short-term memory loss during the dark interval.
- Effects of memory deterioration predominate at short intervals and effects of involuntary eye movements predominate at longer intervals.

Variability

Threshold and PSE measures represent standard deviation and median, respectively, of each observer's offset judgments. Considerable observer variability in threshold acuity and PSE is observable in the figure. Observer 1's PSE shifted to the right late in the interval after an earlier shift to the left.

Repeatability/Comparison with Other Studies

Two other experiments, conducted using the same procedure without monitoring eye movements, show the same deterioration with increasing interval length. However, thresholds for each observer were twice as high for the same observers that were in the eye movement experiment. Wearing of the contact lens may have been responsible.

A previous experiment (Ref. 4) also showed that eye movements produced discrimination error when observers judged the visual direction of a small circular target relative to a preceding fixation target, while maintaining fixation during a 3-sec dark interval between the two.

Constraints

- Only the effects of horizontal eye movements were considered.
- Visual acuity is influenced by a number of factors (such as luminance level, viewing distance, and exposure time) which must be considered in applying these results under different conditions (CRef. 1.603).

Key References

1. Matin, L. (1972). Eye movements and perceived visual direction. In D. Jameson & L. Hurvich (Eds.), *Handbook of sensory physiology: Vol. VIII/4. Visual psychophysics* (pp. 331-380). Heidelberg: Springer-Verlag.

2. Matin, L. (1976a). A possible hybrid mechanism for modification of visual direction associated with eye movements—The paralyzed eye experiment reconsidered. *Perception*, 5, 233-239.

3. Matin, L. (1976b). Saccades and extraretinal signal for visual direction. In R. A. Monty & J. W. Send-

ers (Eds.), *Eye movements and psychological processes* (pp. 205-219). Hillsdale, NJ: Erlbaum.

4. Matin, L., Pearce, D.G., Matin, E., & Kibler, G (1966). Visual perception of direction: Roles of local sign, eye movements, and ocular

proprioception. *Vision Research*, 6, 453-469.

*5. Matin, L. Pola, J., Matin, E., & Picoult, E. (1981). Vernier discrimination with sequentially flashed lines: Roles of eye movements, retinal offsets, and short-term memory. *Vision Research*, 21, 647-656.

Cross References

1.603 Factors affecting visual acuity;

1.607 Vernier acuity and orientation sensitivity: effect of adjacent contours;

1.608 Two-dot vernier acuity: effect of dot separation;

1.904 Methods of measuring eye movements;

1.911 Visual fixation stability in the dark;

1.912 Fixation stability: magnitude of horizontal drift;

1.914 Monocular fixation on stationary targets;

1.916 Visual fixation on dimly illuminated targets;

Handbook of perception and human performance. Ch. 20, Sect. 4.2

1.611 Visual Acuity: Effect of Target Location in the Visual Field at Photopic Illumination Levels

Key Terms

Daytime vision; minimum angle of resolution; photopic vision; retinal location; spatial resolution; target acquisition; vernier offset discrimination; visual acuity; visual field location

General Description

For photopic (daylight) levels of illumination ($>0.03 \text{ cd/m}^2$), visual acuity decreases as target distance from fixation (retinal eccentricity) increases. The rate of increase varies with the acuity task as well as with eccentricity. When performance is measured as minimum angle of resolution (angular width of the smallest pattern detail that can be resolved or judged correctly), acuity decreases as an approximately linear function of distance from fixation up to ~ 20 deg of visual angle; at greater eccentricities, minimum angle increases at an accelerated rate.

Applications

Measurement of acuity; situations in which visual resolution of small detail must be maximized.

Methods

Test Conditions

Study 1 (Ref. 5)

- Target was square patch of rectangular-wave grating (bar pattern) with 6 periods (i.e., 12 bar widths) per side; grating presented vertically or horizontally
- Target 0-20 deg from fixation
- Mean luminance 64-80 cd/m^2 ; high (unspecified) contrast
- Presentation duration 500 msec

Study 2 (Ref. 6)

- Target comprised of two small squares (dots) 1 min arc per side; squares one above the other against dark field; targets displayed on oscilloscope; target luminance 160 cd/m^2
- Targets 0-10 deg from fixation
- Viewing distance 6.8 m

- Binocular viewing with natural pupils
- >300 observations per data point

Study 3 (Ref. 4)

- Black Landolt-C ring projected onto white screen; contrast 0.65; background luminance 2.45 or 245 cd/m^2 ; four gap orientations; presentation duration 220 msec; monocular viewing
- Circular patch of sine-wave grating (bar pattern) 2 deg in diameter; contrast 0.66; mean luminance 1118.2 cd/m^2 ; presented in Maxwellian view with 2.5-mm artificial pupil; viewing distance 1 m; presentation duration 250 msec
- Targets 0-60 deg from fixation; observers' refractive errors corrected at each eccentricity

Figure 1. Minimum angle of resolution (MA) as a function of target distance from fixation. (a) Grating resolution (Study 1). MA is one bar width (in minutes of visual angle) of the finest grating that can be resolved into bars and is calculated as the reciprocal of decimal acuity. Each line is a plot of Eq. 1 (see text) for one observer; the value of $a = 0.33$ for one observer and 0.55 for the other. (From Handbook of perception and human performance) (b) Two-dot vernier acuity (Study 2). MA is the smallest horizontal separation at which observers correctly identify the direction of displacement of the upper dots on 75% of trials (see inset). Lines are plots of Eq. 1. The values of a are 1.08 for one observer and 0.77 for the other. (From Ref. 6) (c) Vertical target separation (see inset) that yields the smallest minimum angle for the two-dot task of panel (b) (Study 2). (From Ref. 6)

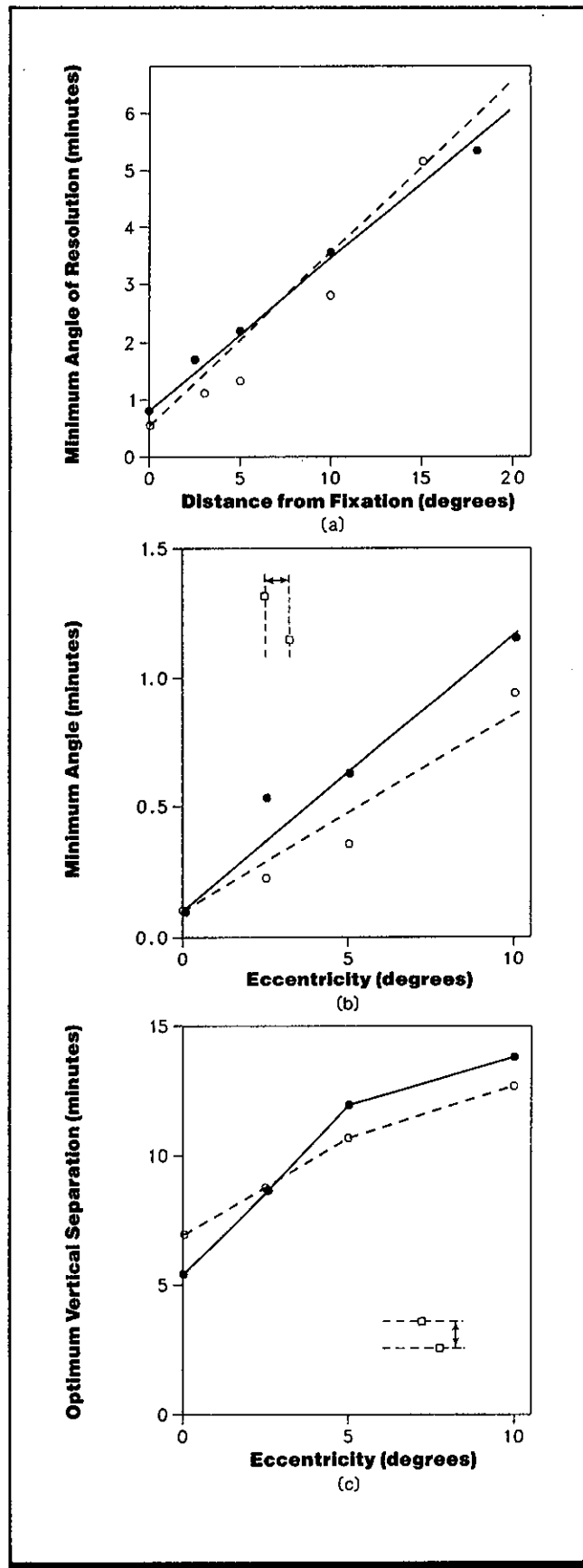

Experimental Procedure

Study 1

- Method of constant stimuli
- Independent variables; orientation of bar pattern, target distance from fixation
- Dependent variable: minimum angle of the finest grating resolved (i.e., the smallest grating with 75% correct identification of orientation), measured in min of visual angle
- Observer's task: identify orientation of grating
- 2 observers with extensive practice

Study 2

- Method of constant stimuli
- Independent variable: target distance from fixation, vertical separation between target dots
- Dependent variables: minimum angle, defined as the smallest horizontal distance between target dots (in min of visual angle) for 75%

correct identifications of direction of displacement of top dot in relation to bottom dot; vertical dot separation at which minimum angle is smallest

- Observer's task: identify whether upper dot was to right or left of lower one
- 2 observers with extensive practice

Study 3

- Method of constant stimuli for Landolt-C targets; staircase procedure for grating targets
- Independent variables: minimum gap width correctly localized on 50% of trials, smallest grating resolvable on 50% of trials
- Observer's task: report orientation of gap for Landolt-C, report presence of bars for grating target
- 5 observers with some practice (2 of the 5 observers provided data for both the Landolt-C and the grating target)

Experimental Results

- Minimum angle of resolution (angular size of the smallest resolvable critical detail in a display) increases as target distance from the fixation point (retinal eccentricity) increases, regardless of the type of acuity task used (grating resolution, two-dot vernier acuity, or Landolt-C gap detection) (Figs. 1a, 1b, 2b).
- The exact shape of this function varies according to the type of task. Minimum angle increases almost twice as fast with target distance from fixation for a two-dot vernier acuity task than for a grating resolution task (Fig. 1). Minimum angle increases more slowly for a grating resolution task than for a Landolt-C task as the target is presented further into the periphery of the visual field (Fig. 2b).
- When illumination is at photopic levels and the retinal eccentricity of the target is <20 deg, acuity measured in terms of the minimum angle of resolution approximates a linear function of distance from fixation and can be described by the following equation:

$$MA(E) = MA(0) [1 + aE] \quad (1)$$

where $MA(E)$ is minimum angle at a given retinal eccentricity, $MA(0)$ is minimum angle at fixation, E is target distance from fixation, and a is a parameter that varies with the acuity task used.

- The effect of target eccentricity on acuity changes as luminance level changes. For acuity measured with Landolt-C rings, the difference in acuity between the center of the visual field and the periphery is greater at high luminance levels than at low luminance levels (Fig. 2).
- Optimal vertical target separation for a two-dot vernier stimulus increases as target distance from fixation increases, but the rate of percentage increase is much less than the rate of increase in minimum angle of resolution (Study 2).
- Errors in refraction (due primarily to astigmatism) do not influence acuity in the periphery of the retina.

Variability

In Studies 1 and 2, standard-errors of the mean were $\sim 10\%$ (as estimated by probit analysis). In Study 3, standard deviations of the mean were $\sim 25\%$.

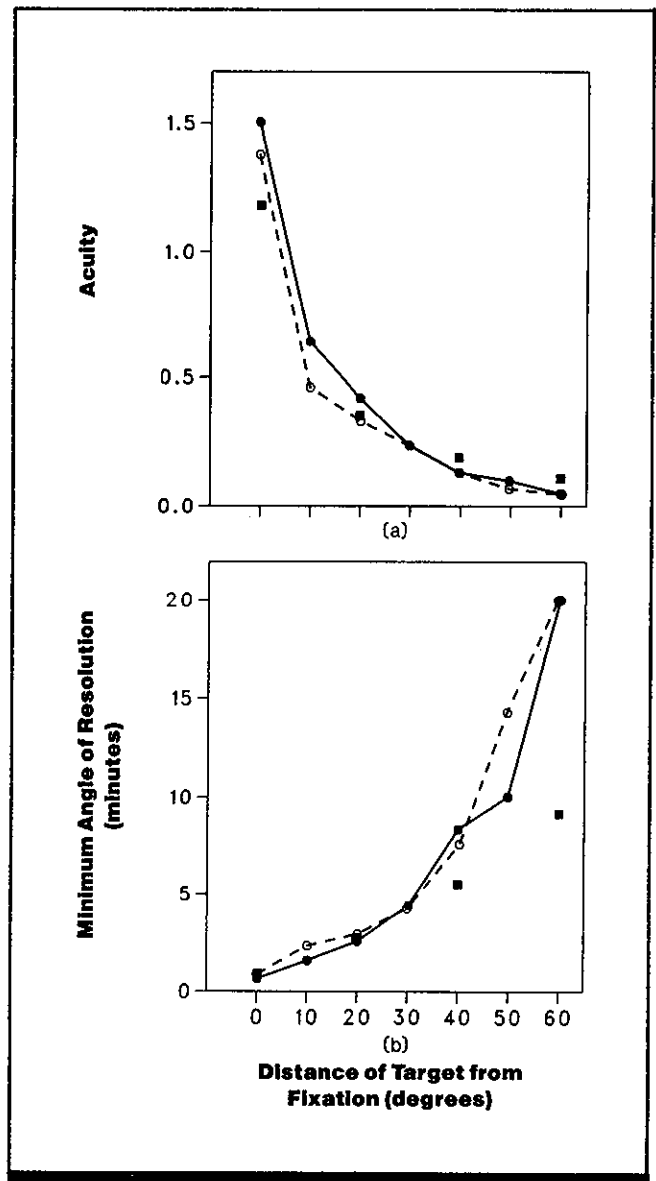

Figure 2. Visual acuity as a function of target distance from fixation (Study 3). (a) Decimal acuity. Three different targets were used: Landolt-C rings at a background luminance of 2.45 cd/m^2 (open circles); Landolt-C rings at a background luminance of 245 cd/m^2 (closed circles) and sine-wave gratings (squares). For the Landolt-C target, acuity is the reciprocal of the width (in minutes) of the smallest gap that can be localized; for the grating target, acuity is the reciprocal of the width (in minutes) of one bar of the finest grating that is resolvable into bars. (b) Minimum angle of resolution (reciprocal of decimal acuity) for the three targets. (From *Handbook of perception and human performance*, based on data from Ref. 4)

Repeatability/Comparison with Other Studies

The findings of Study 3 are consistent with prior research showing that acuity declines most for targets >20 deg from fixation. However, acuity values presented here are much less than those of Ref. 3 for Landolt-C targets. Reference 7 found that the minimum angle of resolution increased linearly with increasing distance from fixation up to ~ 30 deg (rather than 20 deg as reported here and elsewhere).

Constraints

- Research findings are difficult to compare because acuity values vary according to the assessment procedure used.
- Practice has a strong impact on acuity.

- Visual acuity is influenced by a number of factors (such as luminance level, viewing distance, and exposure time) which must be considered in applying these results under different conditions (CRef. 1.603).

Key References

1. Anstis, S. M. (1974). A chart demonstrating variations in acuity with retinal position. *Vision Research*, 14, 589-592.
2. Ludvigh, E. (1941). Extrafoveal visual acuity as measured with Snellen test-letters. *American*

- Journal of Ophthalmology*, 24, 303-310.
3. Mandelbaum, J., & Sloan, L. L. (1947). Peripheral visual acuity. *American Journal of Ophthalmology*, 30, 581-588.
 - *4. Millodot, M., Johnson, C. A., Lamont, A., & Leibowitz, H. W.

- (1975). Effect of dioptics on peripheral visual acuity. *Vision Research*, 15, 1357-1362.
- *5. Westheimer, G. (1979). Scaling of visual acuity measurements. *Archives of Ophthalmology*, 97, 327-330.

- *6. Westheimer, G. (1982). The spatial grain of the perifoveal visual field. *Vision Research*, 22, 157-162.
7. Weymouth, F. W. (1958). Visual sensory units and the minimum angle of resolution. *American Journal of Ophthalmology*, 46, 102-113.

Cross References

- 1.602 Measurement of visual acuity;
- 1.603 Factors affecting visual acuity;

- 1.604 Visual acuity: effect of luminance level;
- 1.608 Two-dot vernier acuity: effect of dot separation;
- 1.612 Visual acuity; effect of target location in the visual field at scotopic illumination levels;

- 1.616 Visual acuity: effect of viewing distance and luminance level;
- Handbook of perception and human performance*, Ch. 7, Sect. 1.3, 4.3

Notes

(
(
(
(
(
(

1.612 Visual Acuity: Effect of Target Location in the Visual Field at Scotopic Illumination Levels

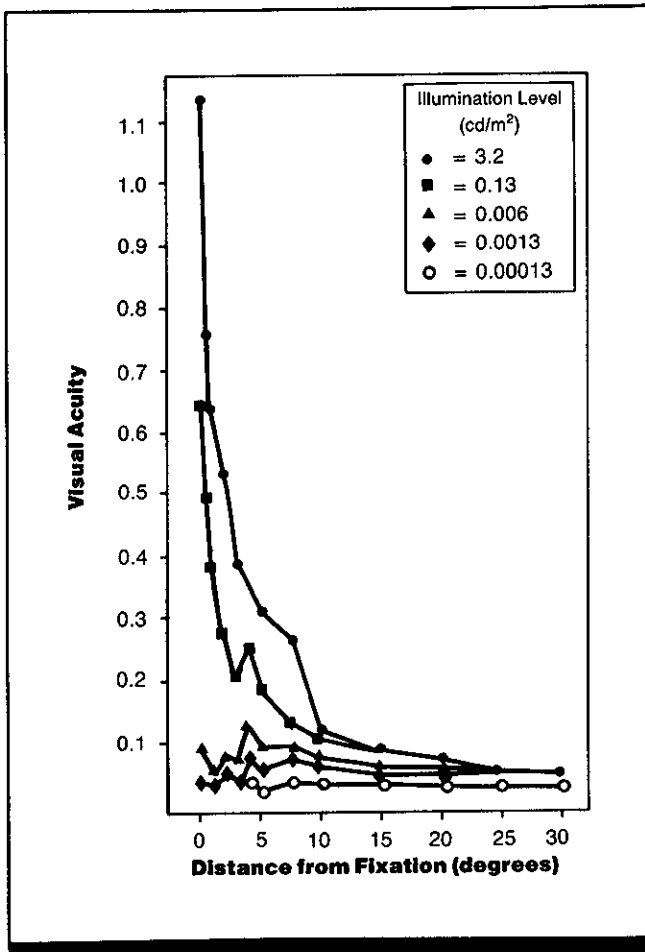

Figure 1. Visual acuity (measured along the horizontal meridian of the temporal retina) as a function of distance of target from fixation. Data are shown for 5 different levels of illumination. The lowest three levels (0.006-0.00013 cd/m^2) represent scotopic illumination; 3.2 cd/m^2 represents photopic illumination; and 0.13 cd/m^2 falls in the range of overlap of scotopic and photopic vision. The curves for the four highest illumination levels are almost identical at >25 deg eccentricity and are indicated by single points. Data are for 1 observer. (From J. Mandelbaum & L. L. Sloan, *American Journal of Ophthalmology*, 30, 581-588. Published with permission from the American Journal of Ophthalmology. Copyright by the Ophthalmic Publishing Co.)

Key Terms

Minimum angle of resolution; night vision; retinal location; scotopic vision; spatial resolution; target acquisition; visual acuity; visual field location

General Description

Maximum visual acuity at **scotopic** levels of illumination occurs with the target positioned at 4-8 deg from the fixation point. At very low light levels, visual acuity is approximately constant for targets from 4-30 deg from fixation. Thus the function relating visual acuity to distance from fixation (retinal eccentricity) is approximately constant for tar-

gets from 4-30 deg from fixation. The function relating visual acuity to distance from fixation (retinal eccentricity) is very different for scotopic and **photopic** light levels; for photopic levels of illumination, acuity decreases rapidly as an approximately linear function of retinal eccentricity for target distances less than ~ 20 deg from fixation (CRef. 1.611).

Applications

Measurement of acuity; situations in which visual resolution of small detail must be maximized.

Methods

Test Conditions

- Black Landolt-C target 2-, 6-, and 12-mm diameter projected in one of four orientations onto center of white screen; projected image size from 12.5-245 mm; fixation point at one of several vertical distances from center of screen; dark room
- Light intensity from ~ 0.00006 - 3 cd/m^2 (0.00002 - 1 mL)

- Target distance from fixation point 0-30 deg; exposure duration of 0.2 sec for peripheral vision, several seconds for foveal targets
- Measures taken in horizontal meridian from fovea to 30 deg from fixation
- **Monocular and binocular** viewing; viewing distance from 2-10 m (distance was decreased or increased as needed to provide the necessary visual angle); each run lasted ~ 45 min

Experimental Procedure

- Method of constant stimuli; trials at all illumination levels in descending order comprised experimental run for each distance from fixation
- Independent variables: illumination level, target distance from fixation
- Dependent variable: visual (decimal) acuity, defined as the reciprocal of the minimum angle of resolution (angular width of gap in

Landolt-C at which responses were 75% correct)

- Observer's task: report position of gap in Landolt-C
- Complete set of measurements made on right eye of 1 observer with extensive practice; general trend confirmed by measurements on another observer with extensive practice; binocular measurements on 18 other observers confirmed peak acuity at 4-8 deg eccentricity

Experimental Results

- At scotopic illumination levels, visual acuity is maximal when targets are 4-8 deg from the fixation point.
- At illumination levels $< 0.006 \text{ cd/m}^2$, acuity is fairly constant from 4-30 deg eccentricity.

- The level of illumination is less critical for peripheral than for foveal (central) acuity.

Variability

Acuity under scotopic illumination peaks at 4-8 deg from fixation for all 20 observers.

Constraints

- Large individual differences in light sensitivity may influence acuity measures across observers.
- Most of the observers gave higher acuity readings when the fixation point was to the right of the test object than to the left of the object. This might be due to right-sided ocular dominance and the apparent superiority of the temporal retina, but no determination could be made.

- Comparison between horizontal and vertical fixations for 3 observers indicated that acuity improves by 10% for horizontal fixations.
- Visual acuity is influenced by a number of factors (such as luminance level, viewing distance, and exposure time) which must be considered in applying these results under different conditions (CRef. 1.603).

Key References

*1. Mandelbaum, J., & Sloan, L.L. (1947). Peripheral visual acuity: With special reference to scotopic illumination. *American Journal of Ophthalmology*, 30, 581-588.

Cross References

1.602 Measurement of visual acuity;
1.603 Factors affecting visual acuity;

1.604 Visual acuity: effect of luminance level;

1.611 Visual acuity: effect of target location in the visual field at photopic illumination levels;

1.616 Visual acuity: effect of viewing distance and luminance level;

Handbook of perception and human performance, Ch. 7, Sect. 1.3.2

1.613 Visual Acuity: Effect of Exposure Time

Key Terms

Exposure duration; gap detection; minimum angle of resolution; spatial resolution; target acquisition; visual acuity

General Description

Visual acuity for a static target can increase with exposure time up to durations of ~600 msec, although it may plateau as quickly as 300 msec. The improvement in vision is not due to pupillary or accommodative (focus) fluctuations, nor is it simply a function of the total light energy reaching the retina.

Applications

Measurement of acuity; situations in which visual resolution of small detail must be maximized.

Methods**Test Conditions**

- White Landolt-C ring of variable size back-projected onto a glass aperture in a gray screen 9 m away from subject
- Background luminance was 25.28 cd/m²
- Target luminance was 127 cd/m²
- Target-exposure durations from 100-800 msec
- 90% rise and fall time of exposures was 2 msec; size of Landolt-C ring adjusted by zoom-lens system; neutral density filters used to maintain average luminance constant within 40% for different-sized stimuli

Experimental Procedure

- Method of limits; trials blocked by exposure duration
- Independent variable: exposure duration
- Dependent variable: minimum angle of resolution, defined as the smallest Landolt-C gap (in min arc of visual angle) for which the position of the gap was correctly detected; data corrected for guessing and threshold computed by probit analysis
- Observer's task: identify the apparent orientation of the Landolt-C gap as up, down, right, or left
- 2 subjects with extensive practice

Experimental Results

- Visual acuity (measured as the angular size of the smallest resolvable pattern detail) increases with exposure duration for briefly presented targets. Acuity reaches the maximum within 300-600 msec.
- Related experiments investigating the effects of pupil size and accommodation (eye focus) show that controlling these factors does not influence the time-dependence of visual acuity. Hence, the oculomotor systems controlling these functions are not the mechanism underlying increases in acuity with increases in exposure time (Ref. 1).
- A related experiment varying luminance of the target up to 500 cd/m² shows that acuity does not improve with increasing luminance at a given exposure duration (Ref. 1). Therefore, the increase in acuity with exposure time is not due simply to an increase in light energy (luminance × duration) at the retina and thus increased light level cannot be substituted directly for exposure time.
- Another related experiment obtained comparable results for double target flashes presented one to each eye. This

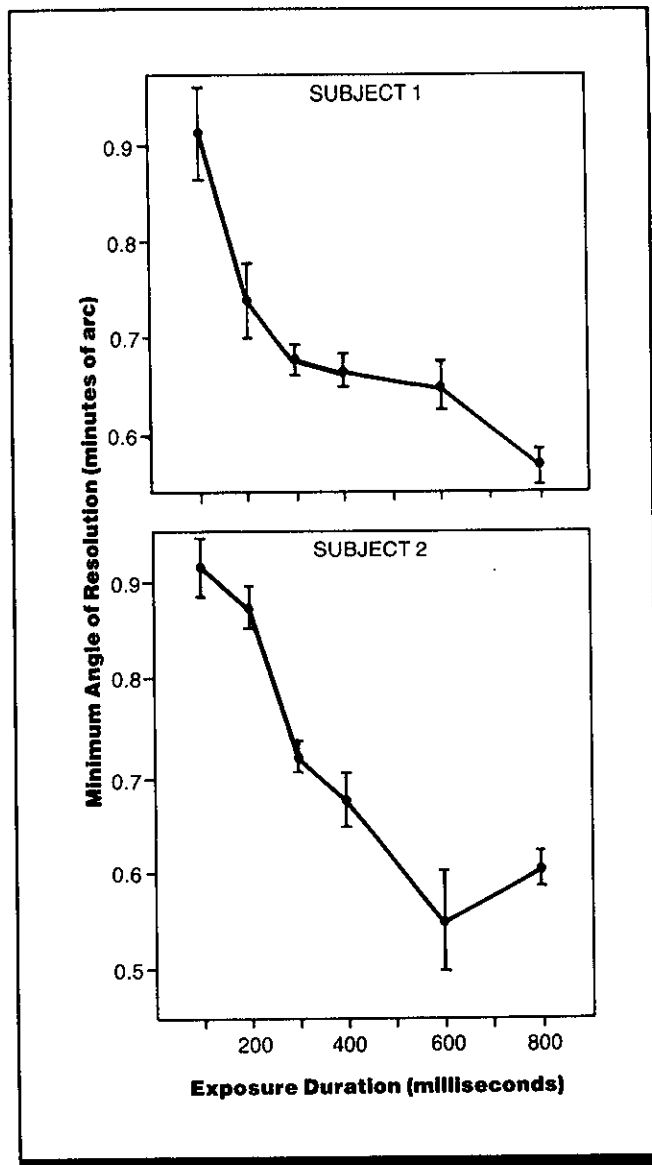

Figure 1. Minimum angle of resolution (angular size of the smallest resolvable gap in a Landolt-C) as a function of exposure duration. Data are shown for 2 observers; 50% limits of the mean are indicated by the vertical bars. (From Ref. 1)

suggests that the improvement in acuity with exposure time reflects the operation of a neural sampling mechanism operating at a central level.

Variability

Fifty-percent limits of the mean (shown as error bars in Fig. 1) were calculated using probit analysis and never exceeded ± 0.5 min arc. Reference 1 notes that the point for 800 msec exposure duration cannot be consistently and reliably reproduced.

Repeatability/Comparison with Other Studies

Reference 3 also found visual acuity to increase as exposure duration increases: this increased acuity was found both with normal viewing and with retinal stabilization of the target.

Earlier work has described a time-luminance reciprocity for visual acuity. However, these studies used **mesopic** viewing conditions (relatively low illumination) instead of the **photopic** conditions (high luminance levels) described here, and hence tested performance at less than maximal acuity levels (Ref. 2).

Constraints

- The method of limits employed here can lead to expectancy effects in threshold determination, since independent variable values increase or decrease steadily toward the threshold value. As a result, precise value for decimal acuity (the reciprocal of minimum angle of resolution)

should be interpreted only qualitatively, and may vary under different conditions.

- Visual acuity is influenced by a number of factors (such as luminance level, viewing distance, and exposure time) which must be considered in applying these results under different conditions (CRef. 1.603).

Key References

*1. Baron, W. S., & Westheimer, G. (1973). Visual acuity as a function of exposure duration. *Journal of the Optical Society of America*, 63, 212-219.

2. Graham, C. H., & Cook, C. (1937). Visual acuity as a function

of intensity and exposure time. *American Journal of Physiology*, 49, 645-691.

3. Keesey, V. T. (1960). Effects of involuntary eye movements on visual acuity. *Journal of the Optical Society of America*, 50, 769-774.

4. Shlaer, S., Smith, E. L., & Chase, A. M. (1941). Visual acuity

and illumination in different spectral regions. *Journal of General Physiology*, 25, 553-569.

5. White, C. T., & Ford, A. (1960). Eye movements during simulated radar search. *Journal of the Optical Society of America*, 50, 909-913.

Cross References

1.602 Measurement of visual acuity;

1.603 Factors affecting visual acuity;

1.614 Visual acuity: effect of pupil size

1.614 Visual Acuity: Effect of Pupil Size

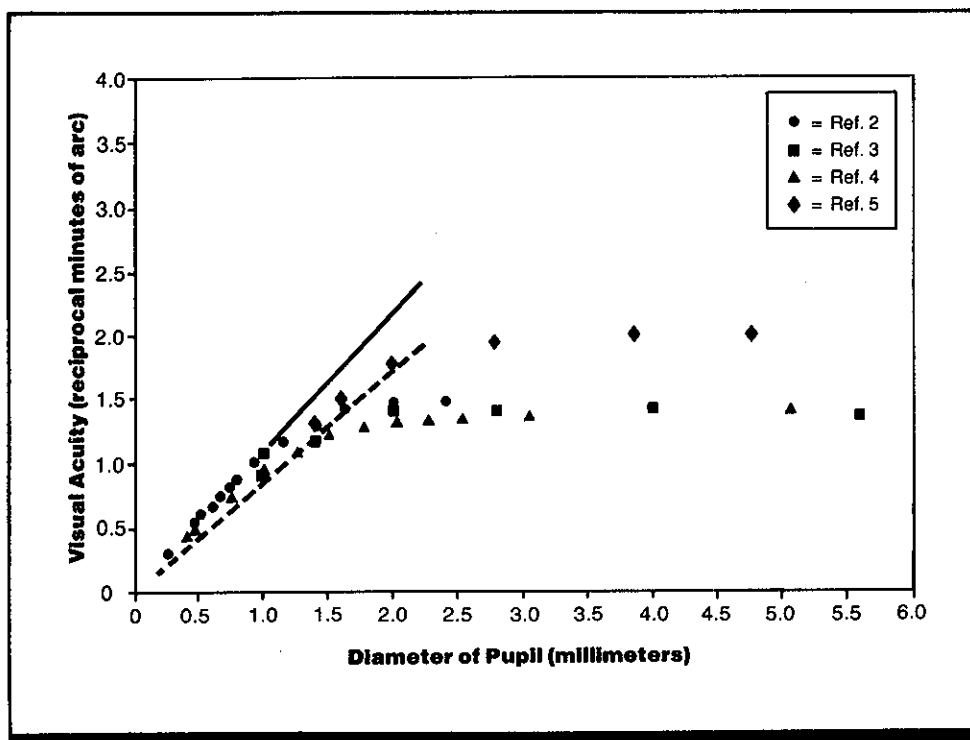

Figure 1. Effect of pupil size on visual acuity for four different studies. Visual acuity is the reciprocal of the smallest resolvable pattern detail (i.e., width of bar in grating pattern or width of gap between bars in two-bar pattern) in minutes of arc of visual angle. The dashed line represents the calculated Rayleigh limit on acuity; the solid line represents limit (both formulations assume visual resolution to be limited by light diffraction). (From Ref. 6)

Key Terms

Diffraction; gap detection; pupil size; spatial resolution; visual acuity

General Description

The visual acuity of the human eye reaches its maximum with a pupil diameter of between 2.5 and 4.0 mm. With a small pupil (<1 mm), acuity is close to that which would be predicted if visual resolution were limited by the diffraction

of light (CRef. 1.213). The failure of acuity to increase with pupil size >2.5 mm probably represents a tradeoff between reduced diffraction effects and increased optical aberration of the eye (optical errors that reduce image quality). With larger pupils, individual physiological and psychological differences have an increasingly greater effect on acuity.

Applications

Measurement of acuity; situations in which visual resolution of small detail must be maximized.

Methods

Methodological details are given in Table 1.

Experimental Results

- For small pupils (<1 mm), visual acuity values are close to those predicted from the theoretical limits on the resolution of an optical instrument due to the diffraction of light. According to the so-called Rayleigh limit, two points will be just barely resolved when their angular separation,

α_s , is $\alpha_s = 1.22 \lambda/d_0$ in radians, where λ is the wavelength of the light and d_0 is pupil diameter. A revised equation for diffraction limits on resolution, known as the Dawes limit, is $\alpha_s' = \lambda/d_0$. For the studies reported here, the data for pupils <1 mm are slightly better than those predicted by the Rayleigh limit, and are very well fit by the Dawes limit (Fig. 1).

Table 1. Test conditions and procedures for studies examining the effect of pupil size on visual acuity.

Source	Test Conditions	Experimental Procedure
Study 1 (Ref. 2)	Square-wave grating	Distance of artificial pupil from eye not specified
	Nature of illumination not specified	Observer's task: adjust angle so that grating just visible
	Luminance over entire grating including interspaces was 995 cd/m ²	Number of observers not specified, possibly a single observer
Study 2 (Ref. 4)	Square-wave grating	Artificial pupil located 3 mm from eye (exact method not specified, probably method of limits)
	Tungsten and mercury arc illumination	Observers's task: adjust angle so that grating just visible
	Target luminance 1713 cd/m ²	16 observers
Study 3 (Ref. 3)	Two light bars with a square-wave luminance distribution	Metal pupil 15 mm in front of eye pupil
	Incandescent illumination	Observer's task: adjust target size so bar separation just visible
	Retinal illuminance of 150 trolands (equivalent to scene luminance of 10 cd/m ² with a natural pupil)	3 observers
Study 4 (Ref. 5)	Square-wave grating filling 4-deg diameter display field	Monocular viewing
	Incandescent illumination	Observer's task: report minimum grating size at which orientation was detectable
	Retinal illuminance of 1000 trolands (equivalent to scene luminance of 110 cd/m ² with a natural pupil) Surround probably dark	2 observers; only 1 observer for the largest pupil condition

Key References

1. Byram, G. M. (1944). The physical and photochemical basis of visual resolving power. I. The distribution of illumination in retinal images. *Journal of the Optical Society of America*, 34, 571-591.

*2. Byram, G. M. (1944). The physical and photochemical basis of visual resolving power. II. Visual acuity and photochemistry of the retina. *Journal of the Optical Society of America*, 34, 718-738.

*3. Cobb, P. W. (1914-1915). The influence of pupillary diameter on visual acuity. *American Journal of Physiology*, 36, 335-346.

*4. Coleman, H. S., Coleman, M. F., Fridge, D. L., & Harding, S. W. (1949). The coefficient of specific resolution of the human eye for Foucault test objects viewed through circular apertures. *Journal of the Optical Society of America*, 39, 766-770.

*5. Liebowitz, H. (1952). The effect of pupil size on visual acuity for photo-metrically equated test fields at various levels of luminance. *Journal of the Optical Society of America*, 42, 416-422.

6. Riggs, L. A. (1966). Visual acuity. In C. H. Graham (Ed.), *Vision and visual perception*. New York: Wiley.

7. Shlaer, S. (1937). The relation between visual acuity and illumination. *Journal of General Physiology*, 25, 165-188.

8. Westheimer, G. (1963). Optical and motor factors in the formation of the retinal image. *Journal of the Optical Society of America*, 62, 86-93.

Cross References

1.211 Spherical aberration;
1.212 Axial chromatic aberration;

1.213 Diffraction of light in optical systems;
1.214 The point-spread function of the eye;

1.603 Factors affecting visual acuity;
1.604 Visual acuity: effect of luminance level

1.615 Visual Acuity: Effect of Viewing Distance

Key Terms

Depth perception; gap detection; spatial resolution; stereo-acuity; target acquisition; three-dimensional displays; viewing distance; visual acuity

General Description

Both visual acuity and stereoacuity (ability to discriminate depth differences) improve as viewing distance increases through an intermediate range, and sometimes both decline when the target reaches a certain distance. Stereoacuity also declines when accommodation (eye focus) and convergence do not have their normal relationship.

Applications

Measurement of acuity; situations in which visual resolution of small detail or discrimination of depth must be maximized; design of binocular optical instruments.

Methods (across studies)

Test Conditions

- Visual acuity tested with checkerboard targets viewed under illumination of 86 lux (8 fc) or with a pair of bars whose luminance was $\sim 34 \text{ cd/m}^2$ (10 fL); stereoacuity tested with a pair of vertical lines on a background illuminated to 12-150 cd/m^2 or with a pattern of gray disks (critical limen stereo test; Ref. 3) whose luminance was $\sim 12\text{-}50 \text{ cd/m}^2$ against a background of $\sim 7 \text{ cd/m}^2$
- Target distances from 0.2 m to either 10 m or optical infinity

Experimental Procedure

- Standard psychophysical methods
- Independent variables: target

distance, lateral retinal image disparity, relation between accommodation and convergence

- Dependent variables: size of target that could be resolved at each distance, minimum retinal disparity for correct detection of depth at each distance
- Observer's task: discriminate checkerboard targets from gray squares of equal brightness, resolve two adjacent high-contrast bars, judge one line as closer or farther than another, detect which one of a row of disks was closer
- 3-400 observers, depending on the study; all were young (average ages ranged from $\sim 20\text{-}30$ yrs.), highly practiced, and screened for good vision

Experimental Results

- Visual acuity improves as the target recedes in distance up to $\sim 5\text{-}10$ m and then may decline.
- Visual acuity measured at one distance is a poor predictor of visual acuity at another distance.
- Stereoacuity improves as the target recedes, but then appears to decline when the target is at optical infinity.
- Stereoacuity declines when accommodation and convergence do not have their normal relationship (i.e., when the eyes are accommodated and converged to different distances) (Ref. 3; CRef. 1.657).

Constraints

- Only relatively young, practiced observers with good vision were tested. Age and uncorrected refractive errors will affect the results.

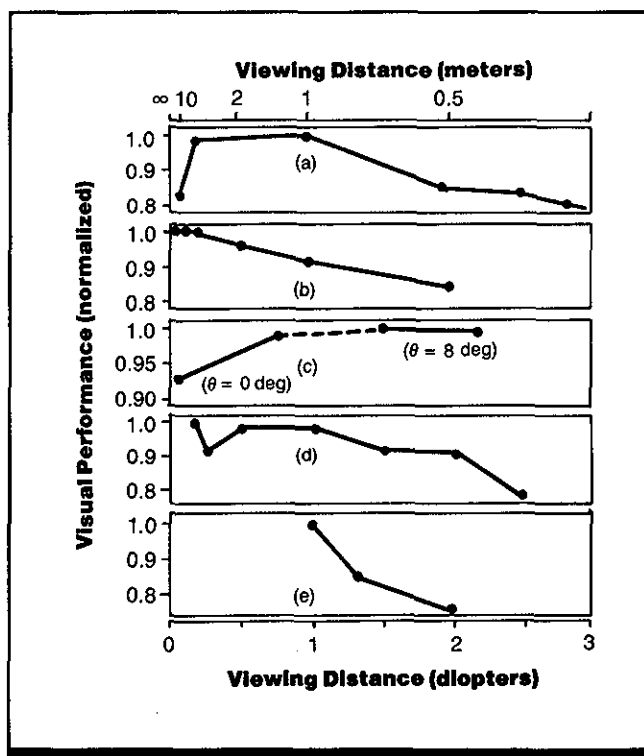

Figure 1. Effects of viewing distance on vision. (a) Visual acuity with checkerboard test ($n = 400$). (From Ref. 5) (b) Visual acuity with Cobb 2-bar test ($n = 7$). (From Ref. 6) (c) Stereoacuity with critical limen test ($n = 32$). (From Ref. 3) (d) Stereoacuity measured with two vertical bars ($n = 3$). (From Ref. 2) and (e) Stereoacuity measured with two vertical bars ($n = 3$). (From Ref. 1) For the curve in (c), θ is the angle of convergence necessary to match viewing distance. Viewing distance is given in both meters and diopters (reciprocal of distance in meters); note that viewing distance in meters decreases from left to right.

Variability

Checkerboard acuity test-retest reliability is ~ 0.85 . The probable error of the acuity measures is $< 2\%$. The standard deviations of the stereoacuity thresholds range from $\sim 1\text{-}7$ sec arc of visual angle, or $\sim 10\text{-}25\%$ of their respective thresholds.

The results in Refs. 2 and 6 do not show the decrease in performance at optical infinity reported in Refs. 3 and 5.

Repeatability/Comparison with Other Studies

Reference 7 reports that stereoacuity is unaffected by viewing distance when all depth cues except lateral retinal image disparity are eliminated.

- Both visual acuity and stereoacuity are influenced by a number of factors (such as luminance level and exposure time) which must be considered in applying these results under different conditions (CRefs. 1.603, 5.918).

Key References

*1. Amigo, G. (1963). Variation of stereoscopic acuity with observation distance. *Journal of the Optical Society of America*, 53, 630-635.

*2. Brown, J. P., Ogle, K. N., & Reiher, L. (1965). Stereoscopic acuity and observation distance.

Investigative Ophthalmology, 4, 894-900.

*3. Farrell, R. J., Anderson, C. D., Kraft, C. L., & Boucek, G. P. (1970). *Effects of convergence and accommodation on stereopsis* (Document No. D180-19051-1). Seattle, WA: Boeing Aerospace Co.

*4. Farrell, R. J., & Booth, J. M. (1984). *Design handbook for imagery interpretation equipment*. Seattle, WA: Boeing Aerospace Company.

*5. Giese, W. J. (1946). The interrelationship of visual acuity at different distances. *Journal of Applied Psychology*, 30, 91-106.

*6. Luckiesh, M., & Moss, F. K. (1941). The variation in visual acuity with fixation-distance. *Journal of the Optical Society of America*, 31, 594-595.

7. Ogle, K. N. (1962). Spatial localization through binocular vision. In H. Davson (Ed.), *The eye* (Vol. 4, pp. 271-324). New York: Academic Press.

Cross References

1.231 Relation between accommodation and convergence;

1.603 Factors affecting visual acuity;

1.616 Visual acuity: effect of viewing distance and luminance level;

1.657 Psychometric functions;

5.918 Factors affecting stereoacuity

1.616 Visual Acuity: Effect of Viewing Distance and Luminance Level

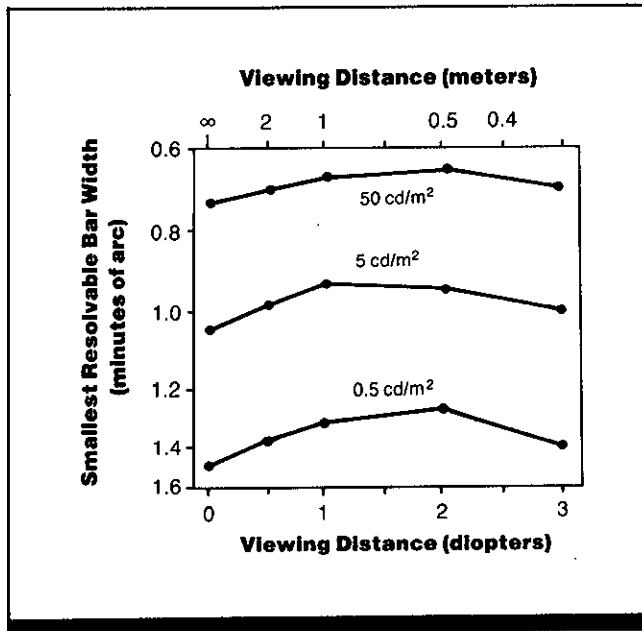

Figure 1. Visual acuity as a function of viewing distance and luminance level. Smallest resolvable bar width is plotted as a function of viewing distance in diopters and meters (note that distance of the target from the observer in meters decreases from left to right). (From Ref. 2, adapted from Ref. 3)

Key Terms

Luminance; spatial resolution; target acquisition; viewing distance; visual acuity

General Description

Visual acuity (measured in terms of the smallest resolvable bar pattern) is best when target distances are ~0.5-1 m and decreases at longer and shorter distances. Viewing distance has a greater impact on acuity at low luminance levels than at high luminances.

Applications

Measurement of acuity; situations in which visual resolution of small detail must be maximized.

Methods

Test Conditions

- 2-deg of visual angle circular sine-wave grating (bar pattern) displayed on circular 10-deg surround field for 250 msec to left eye;
- **Maxwellian view**
- Surround-field luminance of

51.42, 5.14, or 0.51 cd/m²; space-average luminance of grating target of 65.43, 6.54, or 0.65 cd/m²

- **Spatial frequency** of target grating varied in steps of 5 sec arc
- **Optical viewing distance** of 0, 0.5, 1.0, 2.0, or 3.0 diopters (where diopters = 1/distance in meters)

- Observers initially **dark adapted** for 10 min, then presented with surround field for 5 min prior to target presentations

Experimental Procedure

- Double-staircase method with variable step size
- Independent variables: target lu-

minance, background luminance, viewing distance

- **Dependent variable:** spatial frequency of target bar pattern corresponding to 50% detection (plotted as smallest resolvable bar width)
- **Observer's task:** judge if bars were visible
- 4 observers with extensive practice

Experimental Results

- The size of the smallest resolvable bar pattern decreases (i.e., visual acuity increases) as background luminance level increases.
- For any given luminance level, a mid-range viewing distance (1-2 diopters) yields optimal visual acuity.
- Visual acuity varies more with viewing distance at low luminance levels than at high levels.

Variability

Within-observer variability is ~10%. Observers varied somewhat from one another on visual acuity at different luminance levels.

Repeatability/Comparison with Other Studies

Reference 3 presented data for 1 observer who also showed poorer acuity at low luminance levels.

A luminance level of 85 cd/m² (and a contrast of ≥ 0.85) has been recommended for acuity measurement (Ref. 4).

Constraints

- Many factors (such as practice and exposure time) can influence visual acuity and must be considered in applying these results under different viewing conditions. (CRef. 1.603)

Key References

- | | | | |
|---|--|---|---|
| 1. Alpern, M. (1960). Certain effects of background illuminance on accommodation and vergence function. <i>National Academy of Sciences Publication</i> , 835, 64-67. | 2. Farrell, R. J., & Booth, J. M. (1984, February) <i>Design handbook for imagery interpretation</i> (Report No. D180-19063-1). Boeing Aerospace Co. | *3. Johnson, C. A. (1976). Effects of luminance and stimulus distance on accommodation and visual resolution. <i>Journal of the Optical Society of America</i> , 66, 138-142. | 4. National Academy of Sciences. (1980). Recommended standard procedures for the clinical measurement and specification of visual acuity (Rep. of Working Group 39, Committee on Vision). <i>Advances in Ophthalmology</i> , 41, 103-148. |
|---|--|---|---|

Cross References

- | | | |
|---|---|---|
| 1.603 Factors affecting visual acuity; | 1.611 Visual acuity: effect of target location in the visual field at photopic illumination levels; | location in the visual field at scotopic illumination levels; |
| 1.604 Visual acuity: effect of luminance level; | 1.612 Visual acuity: effect of target | 1.615 Visual acuity: effect of viewing distance |

1.617 Visual Acuity with Target Motion: Effect of Target Velocity and Target Versus Observer Movement

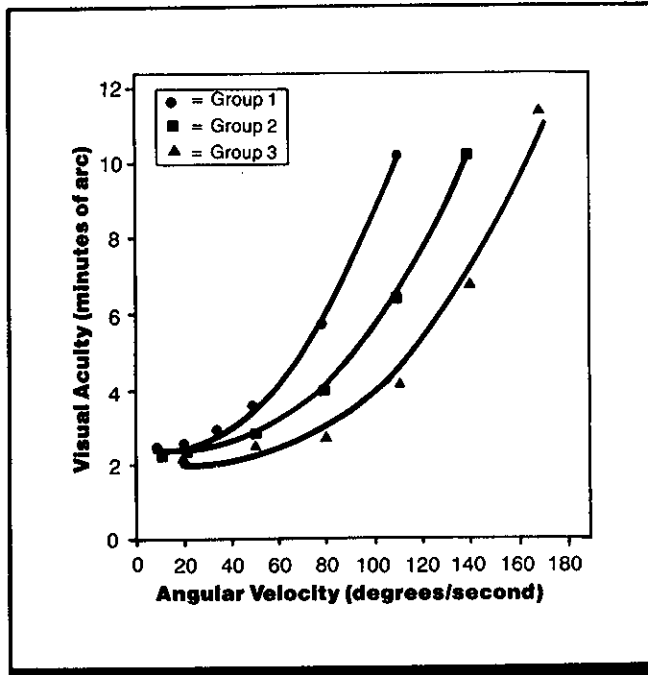

Figure 1. Visual acuity for moving Landolt-C rings for three groups of observers (Study 1). Group 1: those falling an acuity pretest at 140 deg/sec; Group 2: those falling at 170 deg/sec; Group 3: those passing at 170 deg/sec. Ordinate shows size (in minutes of arc) of the smallest detectable gap in Landolt-C target; abscissa shows angular velocity of the target. Data points are observed values; curves represent a plot of Eq. 1, where $a = 2.54, 2.38,$ and $1.92,$ and $b = 5.93 \times 10^{-6}, 2.93 \times 10^{-6},$ and 1.83×10^{-6} for Groups 1, 2, and 3, respectively. (From Ref. 1)

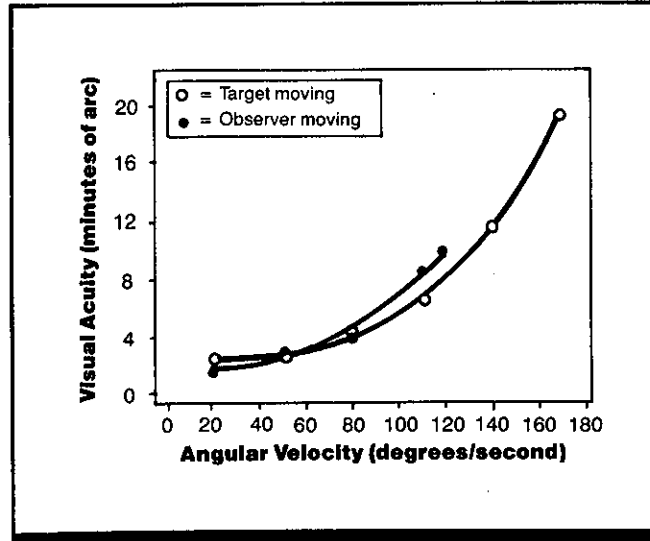

Figure 2. Comparison of visual acuity for Landolt-C rings with target moving versus observer moving. Ordinate shows size (in minutes of arc) of the smallest detectable gap in Landolt-C target; abscissa shows angular velocity of target or observer. Filled circles are observed values from Study 2; for comparison, unfilled circles show averages across all subject groups of Study 1 replotted from Fig. 1. The curves represent plots of Eq. 1 with $a = 2.29$ and $b = 3.46 \times 10^{-6}$ for target moving and $a = 1.94$ and $b = 4.79 \times 10^{-6}$ for observer moving. (From Ref. 3)

Key Terms

Dynamic visual acuity; gap detection; self-motion; spatial resolution; target motion; visual acuity; visual tracking

General Description

Dynamic visual acuity (visual resolution of a moving target) decreases as the angular velocity between a target and an observer increases, regardless of whether the target or the observer is moving. Dynamic visual acuity in either condition is not correlated with static acuity (acuity when neither target nor observer is moving).

Applications

Displays requiring visual resolution of moving targets; visual identification tasks associated with low-altitude, high-speed flight; magnification systems where moving targets are observed and there is no velocity compensation; selection of personnel for roles involving these and similar tasks.

Methods

Test Conditions

Study 1 (Ref. 1)

- Dark Landolt-C rings of various sizes with gap widths ranging from 0.75-11.25 min arc of visual angle (gap equal to 1/5 ring diameter); gap located at one of eight positions (up, down, upper right, lower left, etc.); rings presented using rotating mirror; observer stationary with head in fixed position
- Constant exposure time of 0.4 sec; constant illumination level of 269 lux (25 fc)
- Angular velocity of 10, 20, 35, 50, 80, 110, 140, or 170 deg/sec; observers divided into three groups on basis of pretest performance and tested up to maximum velocity of 110, 140, or 170 deg/sec
- Monocular viewing; optical viewing distance of 4 m

Study 2 (Ref. 3)

- Dark Landolt-C rings of various sizes with gap widths ranging from 1.0-26.0 min arc of visual angle; gap located at one of eight positions; display stationary, observer rotated in Link trainer with head in fixed position
- Constant exposure time of 0.4 sec; constant illumination level of 269 lux
- Angular velocity of 20, 50, 80, 110, 120 deg/sec; observer maintained at given velocity for 1 min before measurements taken
- Monocular viewing; optical viewing distance 282 cm

Experimental Procedure

Study 1

- Method of limits, forced choice among spatial locations
- Independent variables: angular velocity

- Dependent variables: gap detection threshold, determined by reducing size of Landolt-C ring until observer made incorrect response; then next size larger ring presented and called threshold if judged correctly; if this response was also incorrect, then next larger ring was presented (probability of guessing two correct in two trials was 1 in 64)
- Observer's task: track target and indicate orientation of the break (gap) in the Landolt-C; no feedback provided
- Observers told to respond even if guessing
- Twenty threshold determinations at each velocity level
- 18 volunteer Naval enlisted men (ages 17-33 yr) with no practice; all had static visual acuity of 20/20 or better; observers grouped by pretest performance (those failing to detect gap orientation at 140 deg/sec,

those failing at 170 deg/sec, and those passing at 170 deg/sec)

Study 2

- Procedure same as for Study 1 except same size Landolt-C ring presented twice; if observer correct on one trial and incorrect on other trial, that ring size taken as threshold; if observer correct (or incorrect) on both trials, then smaller (or larger) rings presented and threshold determined by interpolation between ring sizes at which observer incorrect on both trials and correct on both trials (probability of guessing two correct in two trials was 1 in 64)
- Ten threshold determinations at each velocity level
- 6 volunteer Naval enlisted men (ages 18-33 yr) with no practice; all had static visual acuity of 20/20 or better

Experimental Results

- Visual acuity (as measured with Landolt-C targets) deteriorates as the angular velocity between target and observer increases (Fig. 1).
- The correlation between static and dynamic acuity is not significant ($r = 0.22$). Individuals with identical static acuities can vary significantly in dynamic acuity by a factor of 3.5.
- Visual acuity deteriorates with increased target velocity in a similar manner, regardless of whether the target or the observer is moving (Fig. 2). The same semi-empirical equation

$$y = a + bx^3 \quad (1)$$

satisfactorily describes data from both studies (where y = acuity in min arc of visual angle; x = angular velocity in deg per sec; a and b are parameters determined by curve fitting using the method of moments, where a is the estimated value of static acuity and b is a measure of dynamic acuity). For comparison, static acuity thresholds with a Landolt-C target and optimal viewing conditions are <30 sec arc (Refs. 4, 5). The a and b parameters for Groups 1, 2, and 3 shown in Fig. 1 are 2.54, 2.38, and

1.92, respectively, for a and 5.93×10^{-6} , 2.93×10^{-6} , and 1.83×10^{-6} , respectively, for b .

Variability

The standard deviations are plotted as bars for each data point in Figs. 1 and 2; the values of b (Eq. 1) for individual subjects varied by as much as 10:1 for a moving target. The internal consistency of dynamic acuity measures using the method described in Study 2 was examined by correlating the means of the odd and even thresholds at 110 deg/sec angular velocity on 200 naval aviation cadets (Ref. 3). The correlation was 0.99 (very high). The test-retest reliability was measured on 120 cadets and found to be 0.65 for the a value and 0.87 for the b value in Eq. 1 after an elapsed time of 10 months (Ref. 3).

Repeatability/Comparison with Other Studies

Dynamic acuity was tested on several thousand naval aviation cadets. Analysis of 1,000 cadets supports conclusions cited in Studies 1 and 2, i.e., testing procedure is reliable; static and dynamic acuity are separate functions with little correlation ($r = 0.09$) (i.e., for a given individual, one cannot be predicted from the other), and visual acuity deteriorates as the angular velocity of the target increases (Ref. 3).

Constraints

- All data were collected with observer's head in fixed position.
- All subjects were male naval personnel already screened for medical fitness.

- Other factors such as age, spectral composition of illumination, viewing distance, exposure time, light level, and direction of movement may affect dynamic acuity and should be considered when applying these data (CRefs. 1.619, 1.620, 1.621, 1.622).

Key References

*1. Ludvigh, E., & Miller, J. W. (1958). Study of visual acuity during the ocular pursuit of moving test objects. I. Introduction. *Journal of the Optical Society of America*, 48, 799-802.

2. Miller, J. W. (1958). Study of visual acuity during the ocular pursuit of moving test objects. II. Effects of direction of movement, relative movement, and illumination. *Journal of the Optical Society of America*, 48, 803-808.

*3. Miller, J. W., & Ludvigh, E. (1962). The effects of relative motion on visual acuity. *Survey of Ophthalmology*, 7, 83-116.

4. Shlaer, S. (1937). The relation between visual acuity and illumination.

Journal of General Physiology, 21, 165-188.

5. Shlaer, S., Smith, E. L., & Chase, A. M. (1942). Visual acuity and illumination in different spectral regions. *Journal of General Physiology*, 25, 553-569.

Cross References

1.603 Factors affecting visual acuity;
1.619 Visual acuity with target mo-

tion: effect of direction of movement and luminance level;
1.620 Visual acuity with target motion: effect of direction of movement and target orientation;

1.621 Visual acuity with target motion: effect of anticipation time and exposure time;

1.622 Visual acuity with target motion: effects of practice;
1.939 Factors affecting smooth pursuit eye movements

1.618 Visual Acuity with Target Motion: Effect of Target Velocity and Orientation

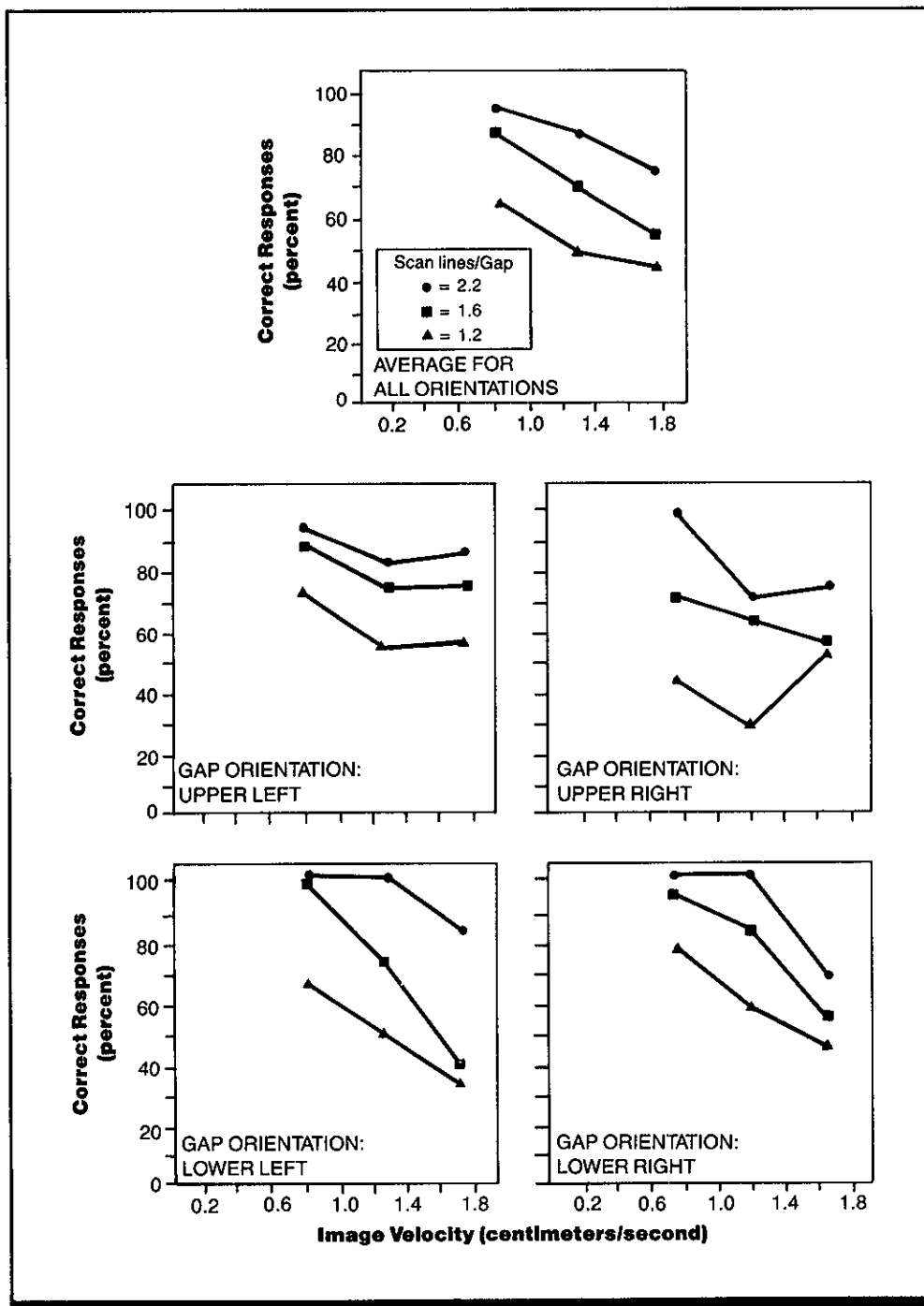

Figure 1. Correct detection of gap orientation for a Landolt-C ring moving downward on a CRT display as a function of image velocity. Data are shown for 3 different gap sizes. Top panel shows results averaged over all gap orientations; bottom four panels, results for each of the four gap orientations tested. (From Ref. 1)

Key Terms

Dynamic visual acuity; gap detection; image motion; spatial resolution; target acquisition; target motion; video displays; visual acuity; visual tracking

General Description

Detection of the orientation of a Landolt-C ring moving down a video display is degraded as gap size decreases and velocity increases. The detection of ring orientation varies greatly, depending on the direction of movement.

Applications

Measurement of acuity; radar and video imaging displays in which visual resolution of small detail must be maximized.

Methods

Test Conditions

- Landolt-C ring moving down 525-TV-line system with bandwidth of 10 MHz and signal-to-noise ratio >30 dB; horizontal raster; P4 phosphor; ambient illumination on monitor faceplate ~32 lux (3 fc)

- Viewing distance 60.96 cm (24 in); display size 13.46 cm²
- One presentation every 5 sec
- Gap in Landolt C made up of 1.2, 1.6, or 2.2 scan lines (1.9, 2.5, or 3.7 min arc of visual angle) for ring heights of 9.3, 12.4, and 18.6 min arc, respectively
- Image velocity 0.76, 1.22, or 1.68 cm/sec

- Gap of Landolt C located at either upper left, upper right, lower left, or lower right

Experimental Procedure

- Method of constant stimuli; feedback conditions not reported
- Independent variables: orientation of Landolt-C ring, height of ring, size of gap, image velocity

- Dependent variable: probability of correct detection of gap orientation
- Observer's task: judge orientation of Landolt-C ring
- At least six trials per observer for each data point
- 12 highly practiced observers

Experimental Results

- Percent correct detection of gap orientation for a Landolt-C ring increases with increasing gap size.
- Percent correct detection of gap orientation decreases as image velocity increases, and therefore as stimulus presentation duration decreases.
- Errors in gap orientation judgments are not random; additional testing shows that observers can much more easily detect whether the gap is on the left or right of a downward moving ring than whether it is on the leading edge or trailing edge of a downward moving ring.

Variability

No information on variability was given.

Repeatability/Comparison with Other Studies

Another study (Ref. 2) found no difference between static visual acuity and dynamic visual acuity (measured with Landolt-C and vernier targets) for target velocities <2.5 deg/sec for horizontal and vertical movement and <1 deg/sec for oblique movement (targets were presented foveally for 0.1 and 0.2 sec).

Constraints

- Many factors (such as luminance, level, exposure time, and practice) can influence acuity and must be considered in applying these results under different viewing conditions (CRef. 1.603).

Key References

*1. Erickson, R. A., Hemingway, J. C., Craig, G. L., & Wagner, D. W. (1974, February). *Resolution of moving imagery on television: Experiment and application*

(Report TP 5619). China Lake, CA: Naval Weapons Center.

2. Westheimer, G., & McKee, S. P. (1975). Visual acuity in the presence of retinal-image motion. *Journal of the Optical Society of America*, 65, 847-850.

Cross References

1.603 Factors affecting visual acuity;
1.617 Visual acuity with target mo-

tion: effects of target velocity and target versus observer movement;
1.619 Visual acuity with target motion: effect of direction of movement and luminance level;

1.620 Visual acuity with target motion: effect of direction of movement and target orientation;
1.939 Factors affecting smooth pursuit eye movements

1.619 Visual Acuity with Target Motion: Effect of Direction of Movement and Luminance Level

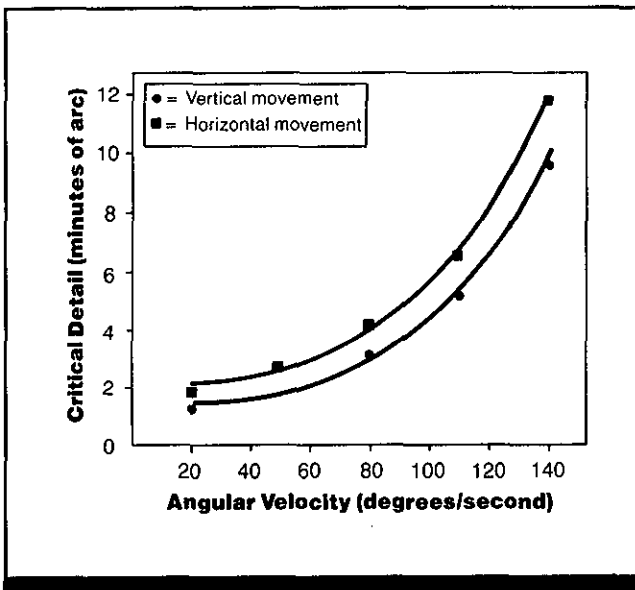

Figure 1. Visual acuity with horizontal and vertical target movement. The ordinate gives the smallest resolvable gap size in a moving Landolt-C target. Curves are fits of Eq. 1 to the data. (From Ref. 2)

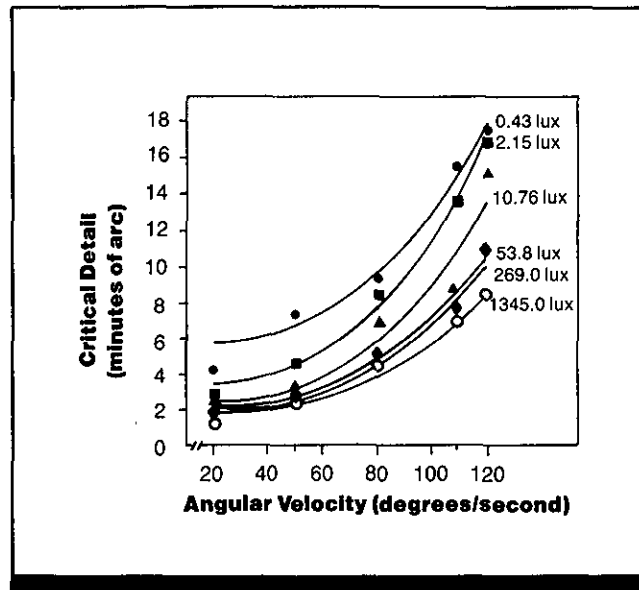

Figure 2. Visual acuity as a function of angular velocity between target and observer, and illumination level. Ordinate shows the smallest resolvable gap size in a Landolt-C target. Target was stationary; observer moved at velocity given on abscissa. Solid lines are graphs of Eq. 1. (From Ref. 2)

Key Terms

Dynamic visual acuity; gap detection; self-motion; spatial resolution; target motion; visual acuity; visual tracking

General Description

Dynamic visual acuity (visual resolution of moving target) decreases as the angular velocity of the target increases regardless of whether movement is in the horizontal or verti-

cal plane (Ref. 2). Increases in target illumination aid dynamic visual acuity up to at least 5433 lux (505 ftc), which is far in excess of illumination needed for good static acuity (Ref. 1).

Applications

Displays requiring visual resolution of moving targets, visual identification tasks associated with low-altitude high-of varying illumination.

are observed and there is not compensation for velocity; selection of personnel for roles involving these and similar tasks; prediction of dynamic visual acuity under conditions of varying illumination.

Methods

Test Conditions

Direction of Movement Study

- Dark Landolt-C rings of various sizes with gap located in one of eight positions (top, bottom, upper left, lower right, etc.); rings presented in both horizontal and vertical plane using rotating mirror; observer stationary with head in fixed position
- Constant exposure time of 0.4 sec; constant illumination level of 269 lux
- Angular velocity of 20, 50, 80, 110, or 140 deg/sec
- Monocular viewing; optical viewing distance 4 m

Illumination Study

- Same targets as described previously, but with display stationary and observer rotated in Link trainer, with head held in fixed position
- Constant exposure time of 0.5 sec; illumination level varied from 0.43 - 1345 lux
- Angular velocity of 0, 20, 50, 80, 110, or 120 deg/sec
- Monocular viewing; optical viewing distance 282 cm

Experimental Procedure (both studies)

- Method of limits, forced choice among spatial locations; no feedback provided

- Independent variables: angular velocity, direction of movement, illumination level
- Dependent variables: gap detection threshold, determined as follows: each size Landolt C presented for two trials; size reduced if observer identified orientation correctly on both trials; when observer correctly located gap on only one of two successive trials with same size Landolt-C ring, that gap size taken as threshold; threshold determined by interpolation when observer was correct (or incorrect) on both trials for a ring and incorrect (or correct) on both trials for the next smaller (or larger) ring; 0.016 probability of correctly

- guessing two correct in two trials
- Observer's task: track target and judge orientation of gap in the Landolt-C ring; observer told to make a response on each trial even if necessary to guess
- 16 threshold determinations at each velocity for direction of movement study; five to ten determinations at each velocity and illumination level for illumination study
- 9 observers for direction of movement study, 6 observers for illumination study; all were volunteer Naval enlisted men (ages 18-33 yr) with static visual acuity of 20/20 or better; no previous practice on similar tasks

Experimental Results

- Visual acuity deteriorates as the angular velocity of the target increases, regardless of whether target movement is in the horizontal or vertical plane (Fig. 1).
- The semi-empirical equation

$$y = a + bx^3 \tag{1}$$

satisfactorily describes both sets of data in Fig. 1, where y = acuity in min arc of visual angle; x = angular velocity in degrees per second; a and b are parameters determined by curve fitting using the method of moments, where a is the estimated value of static acuity and b is a measure of dynamic acuity. The chi-square test for goodness of fit was applied to the curves shown in Fig. 1; theoretical and observed values do not differ significantly.

- Even though dynamic visual acuity is consistently better for vertical movement, the difference is not statistically significant.
- For individual observers, the average correlation between dynamic visual acuity with horizontal target movement and

- acuity with vertical movement is 0.96 (i.e., one is accurately predictable from the other for an individual observer).
- Dynamic visual acuity improves with increased illumination at each angular velocity tested (Fig. 2). With the observer moving and the target stationary, improvement is still observed at 1345 lux.
 - The benefit of increased illumination is greater at higher angular velocities.
 - The higher the angular velocity of the target, the greater the illumination must be in order to maintain a given level of dynamic visual acuity.

Variability

No information on variability was given.

Repeatability/Comparison with Other Studies

For a stationary observer and moving target, when visual pursuit is in a circular plane perpendicular to the line of sight, dynamic visual acuity is still improving at an illumination of 5433 lux at an angular velocity of 90 deg/sec (Ref. 1).

Constraints

- Other factors, such as exposure time, amount of practice, and age of the observer, may affect dynamic acuity thresholds and should be considered in applying these data (CRefs. 1.617, 1.618, 1.621, 1.622).

Key References

<p>1. Ludvigh, E. J. (1949). Visual acuity while one is viewing a moving object. <i>Archives Ophthalmology</i>, 42, 14-22.</p>	<p>*2. Miller, J. W. (1958). Study of visual acuity during the ocular pursuit of moving test objects. II. Effects of direction of movement, relative movement, and illumination. <i>Journal of the Optical Society of America</i>, 48, 803-808.</p>
--	---

Cross References

<p>1.617 Visual acuity with target motion: effects of target velocity and target versus observer movement;</p> <p>1.618 Visual acuity with target motion: effect of target velocity and orientation;</p>	<p>1.620 Visual acuity with target motion: effect of direction of movement and target orientation;</p> <p>1.621 Visual acuity with target motion: effect of anticipation time and exposure time;</p>	<p>1.622 Visual acuity with target motion: effects of practice;</p> <p>1.939 Factors affecting smooth pursuit eye movements</p>
--	--	---

1.620 Visual Acuity with Target Motion: Effect of Direction of Movement and Target Orientation

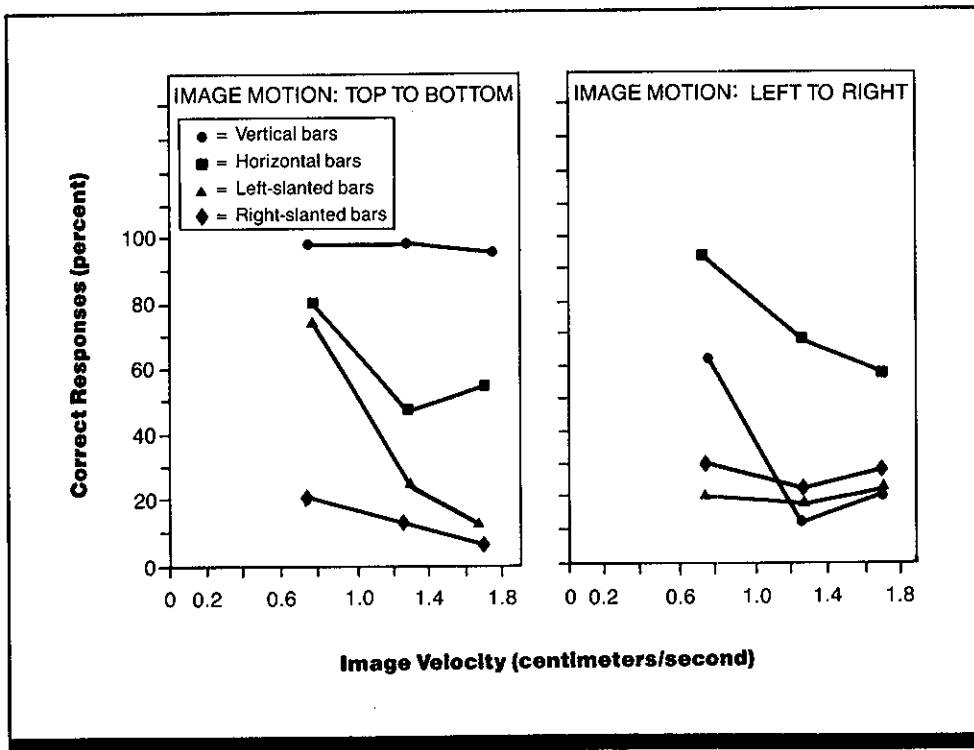

Figure 1. Identification of the orientation of a square-wave bar pattern moving on a video monitor as a function of image velocity, orientation of bars, and direction of movement. (From Ref. 1)

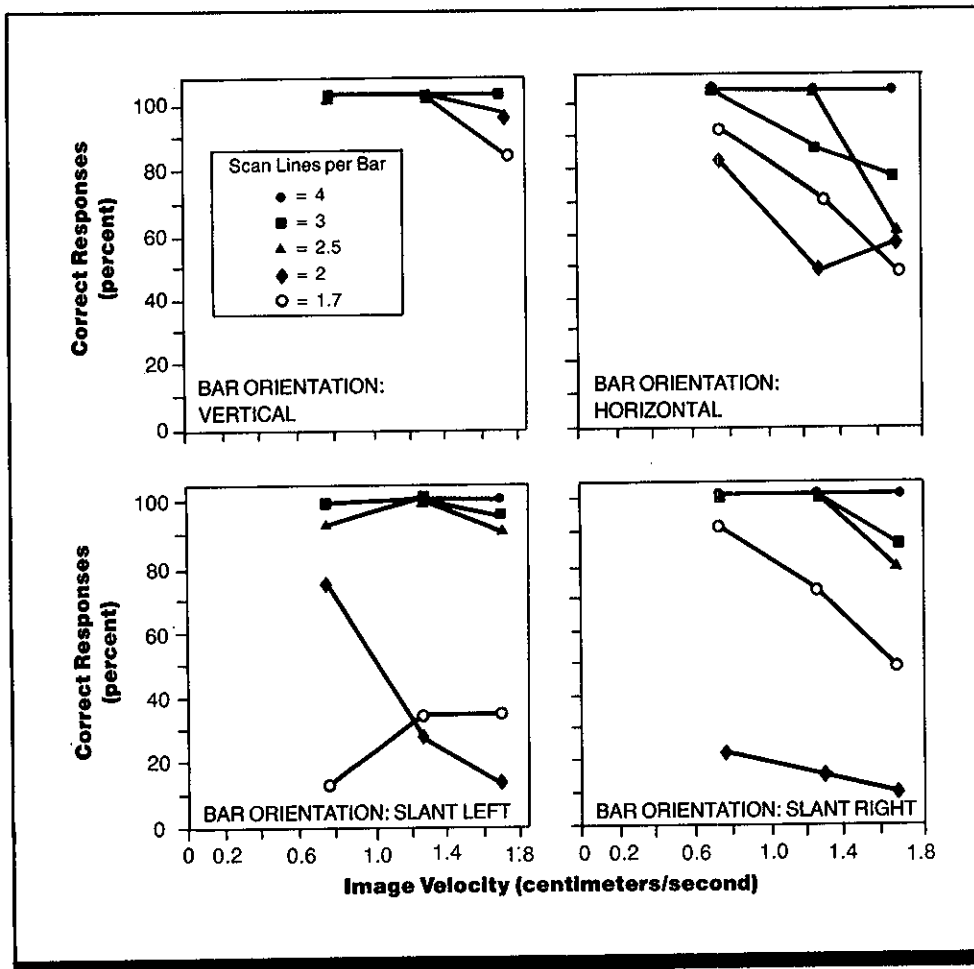

Figure 2. Identification of the orientation of a square-wave bar pattern moving top to bottom on a video monitor as a function of bar width and pattern orientation. (From Ref. 1)

Key Terms

Dynamic visual acuity; orientation; spatial resolution; target acquisition; target motion; video display; visual acuity; visual tracking

General Description

Detection of the orientation of a **square-wave grating** (bar pattern) moving on a video display is degraded as the size of the bars decreases and as image velocity increases. Detection of orientation is strongly dependent upon the direction of movement and orientation of the bar pattern.

Applications

Measurement of acuity; radar and video imaging displays in which visual resolution of small detail on moving targets must be maximized.

Methods

Test Conditions

- Square-wave bar pattern moving top-to-bottom or left-to-right on 525-TV-line system with bandwidth of 10 MHz and signal-to-noise ratio >30 dB; P4 phosphor; ambient illumination on monitor faceplate ~32 lux (3 fc); horizontal raster

- Viewing distance 60.96 cm; display size 13.46 cm square
- One presentation every 5 sec
- Image velocity of 0.76, 1.22, or 1.68 cm/sec
- Each bar 2.0, 3.0, or 4.0 scan lines (2.8, 4.2, or 5.8 min arc of visual angle)
- Orientation of bars could be vertical, horizontal, or slanted 45 deg to left or right

- Bar pattern moved either top to bottom (i.e., across horizontal scan lines) or left to right (along scan lines)

bar, direction of motion of bar pattern, orientation of bar pattern

- Dependent variable: probability of correct detection of bar orientation

Experimental Procedure

- Method of constant stimuli; feedback conditions unknown
- Independent variables: image velocity, number of scan lines per

- Observer's task: identify orientation of bar pattern
- At least six trials per observer for each data point
- 12 highly practiced observers

Experimental Results

- Accuracy in judging the orientation of a moving bar pattern presented via CRT decreases as image velocity increases and therefore as duration of presentation decreases (Figs. 1 and 2).
- Performance is strongly affected by the relation between bar orientation and direction of motion; performance is much better when image motion is parallel to the bars than when it is perpendicular to the bars (Fig. 1).
- Accuracy in identifying the orientation of the bar pattern increases as the size of the bars increases (Fig. 2.).

Variability

No information on variability was given.

Repeatability/Comparison with Other Studies

A more recent study (Ref. 2) found no difference between static visual acuity and dynamic visual acuity (measured with Landolt-C and vernier targets) for target velocities <2.5 deg/sec for horizontal and vertical movement and <1 deg/sec for oblique movement (targets were presented foveally for 0.1 and 0.2 sec).

Constraints

- Many factors, such as luminance level, age, and practice can affect dynamic acuity and must be considered in applying these results under other viewing conditions (CRefs. 1.617, 1.618, 1.619, 1.621, 1.622).

Key References

*1. Erickson, R. A., Hemingway, J. C., Craig, G. L., & Wagner, D. W. (1974, February). *Resolution of moving imagery on televi-*

sion: Experiment and application (Report TP 5619). China Lake, CA: Naval Weapons Center. (DTIC No. AD918949)

2. Westheimer, G., & McKee, S. P. (1975). Visual acuity in the presence of retinal-image motion. *Journal of the Optical Society of America*, 65, 847-850.

Cross References

1.603 Factors affecting visual acuity;

1.617 Visual acuity with target motion: effects of target velocity and target versus observer movement;

1.618 Visual acuity with target motion: effect of target velocity and orientation;

1.619 Visual acuity with target motion: effect of direction of movement and luminance level;

1.621 Visual acuity with target motion: effect of anticipation time and exposure time;

1.622 Visual acuity with target motion: effects of practice;

1.939 Factors affecting smooth pursuit eye movements

1.621 Visual Acuity with Target Motion: Effect of Anticipation Time and Exposure Time

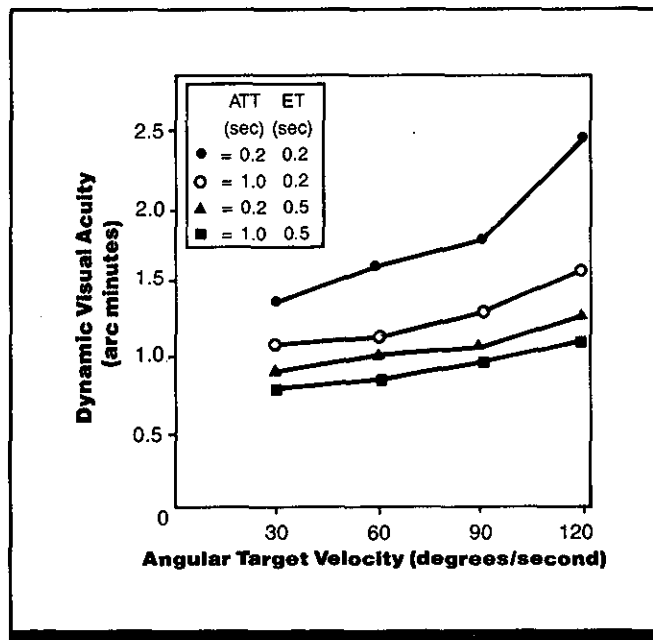

Figure 1. Visual acuity (smallest resolvable target detail) as a function of angular target velocity for various anticipatory tracking times (ATT) and exposure times (ET). (From Ref. 1)

Key Terms

Anticipatory tracking; dynamic visual acuity; expectation; gap detection; spatial resolution; target acquisition; target motion; visual acuity; visual tracking

General Description

Dynamic visual acuity (visual resolution of moving targets) is improved by increasing the anticipatory tracking time (ATT, the time the observer tracks the target location before

the target appears) or target exposure time (ET), or both. Although acuity declines as the velocity of the target increases, the magnitude of the effect is greatly reduced with longer anticipatory tracking and exposure times.

Applications

Displays requiring visual resolution of moving targets; visual identification tasks associated with low-altitude, high-speed flight; magnification systems where moving targets are observed and there is no velocity compensation; selection of personnel for roles involving these and similar tasks.

Methods

Test Conditions

- Landolt-C rings varied from 0.25-12 min of arc at 1-m viewing distance; apparatus for presenting target, after reaching target velocity, moved from left to right around 180-deg arc beginning and ending

in a plane through observer's shoulders

- Anticipatory tracking time (ATT) of 0.5 or 1.0 sec; during ATT, subject visually tracked target apparatus (location in which target would appear), but no target was present
- Target exposure duration of 0.2 or 0.5 sec

- Observer's left eye covered by patch, helmet prohibited all but horizontal rotary movement of observer's head; cardboard screen restricted observer's field of view

Experimental Procedure

- Independent variables: target velocity, anticipatory tracking time, exposure time

- Dependent variable: visual acuity (not defined by author; presumably measured as width of smallest gap in Landolt-C target that could be detected on some given percentage of trials)
- Observer's task: not specified; presumably to report orientation of gap in Landolt-C ring
- 12 observers (ages 16-33), with an unknown amount of practice

Experimental Results

- Visual acuity decreases as target velocity increases under all conditions, but especially when anticipatory tracking time and exposure time are both short (Fig. 1).
- Acuity is improved by increasing anticipatory tracking time and by increasing exposure time (Fig. 1).
- Dynamic visual acuity is very weakly correlated ($r = 0.17$) with static visual acuity.

Constraints

- Tracking acuity was not assessed for irregularly moving targets.
- Dynamic visual acuity is influenced by a number of factors (such as luminance level, practice, and age) which must be considered in applying these results under different conditions (CRefs. 1.617, 1.619, 1.622)

Key References

*1. Elkin, E. H. (1962). Target velocity, exposure time and anticipatory tracking time as determinants of dynamic visual acuity (DVA). *Journal of Engineering Psychology*, 1, 26-33.

2. Ludvigh, E. J., & Miller, J. W. (1958). Study of visual acuity during the ocular pursuit of moving test objects: Introduction. *Journal of the Optical Society of America*, 48, 799-802.

Cross References

1.603 Factors affecting visual acuity;

1.617 Visual acuity with target motion: effects of target velocity and target versus observer movement;

1.618 Visual acuity with target motion: effect of target velocity and orientation;

1.619 Visual acuity with target motion: effect of direction of movement and luminance level;

1.620 Visual acuity with target motion: effect of direction of movement and target orientation;

1.622 Visual acuity with target motion: effects of practice;

1.939 Factors affecting smooth pursuit eye movements;

1.942 Latency and velocity of smooth pursuit eye movements: effect of target velocity;

1.945 Accuracy of tracking eye movements: effect of target velocity

Variability

No information on variability was given.

Repeatability/Comparison with Other Studies

Reference 1 reports much more severe loss of dynamic visual acuity with indirect (mirror) viewing, fixed head position, and no anticipatory tracking (CRefs. 1.617, 1.619).

1.622 Visual Acuity with Target Motion: Effect of Practice

Key Terms

Dynamic visual acuity; gap detection; practice; spatial resolution; target motion; visual acuity; visual tracking

General Description

The ability to resolve fine detail of moving targets (dynamic visual acuity) improves rapidly with practice, with most improvement at higher angular velocity. There are significant individual differences in dynamic visual acuity. Some observers with 20/20 static acuity are so susceptible to increased target velocity effects that practice is of little benefit. There is no correlation between dynamic and static visual acuity.

Applications

Display requiring visual resolution of moving targets; visual identification tasks associated with low-altitude, high-speed flight; magnification systems where moving targets are observed and there is no velocity compensation; selection of personnel for roles involving these and similar tasks.

Methods**Test Conditions**

- Dark Landolt-C rings of various sizes with gap widths ranging from 0.75-11.25 min arc of visual angle (gap widths equal to 1/5 ring diameter); gap located at one of eight spatial positions; rings presented using rotating mirror; observer stationary, with head fixed

- Constant exposure time of 0.4 sec; constant illumination of 269 lux (25 fc)
- Angular velocity of 20 or 110 deg/sec

Experimental Procedure

- Method of limits with forced choice among possible spatial locations of gap

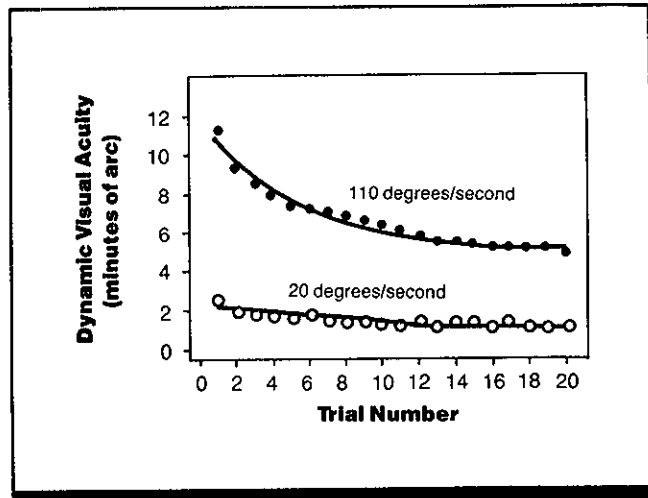

Figure 1. Dynamic visual acuity as a function of practice for two target velocities. (Acuity is measured as the angular size of the smallest detectable gap in a moving Landolt-C target.) (From Ref. 1)

Experimental Results

- Acuity at lower velocities is greater than at higher target velocities. The relationship between visual acuity and the higher angular velocities can be represented by the semi-empirical (curve-fitted) equation

$$y = a + bx^3 \quad (1)$$

where y = critical detail resolvable in min arc of visual angle; x = angular velocity of test target expressed in degrees per second; a and b are parameters determined by curve fitting using the method of moments, where a is the estimated value of static acuity and b is a measure of dynamic acuity (CRef. 1.617).

- Improvement in dynamic visual acuity with practice occurs quite rapidly if there is any improvement at all. Fifty percent of the total improvement at 100 deg/sec occurs by the end of Trial 4.
- The effect of practice is considerable at 100 deg/sec and slight at 20 deg/sec (Fig. 1).
- There are significant individual differences in rate of improvement and in the final acuity values attained ($p = 0.01$).
- Individuals with equal static acuity thresholds can differ significantly in initial dynamic acuity ($p = 0.025$) and

some may show relatively little benefit from practice (CRefs. 1.617, 1.619).

- Retention of improved dynamic acuity performance is high and lasts for at least 7 months.
- The semi-empirical equation $y = L + ce^{-kt}$ describes the learning process of dynamic visual acuity, where y is the dynamic acuity threshold in min arc after trial or time t , and L represents the "final" threshold in min arc after "complete" training; k is the learning rate parameter. When $t = 0$, the above expression reduces to $y = L + c$, and $t \rightarrow \infty$, $y \rightarrow L$. Thus L is the predicted "final" threshold in min arc after "complete" training. This equation enables one to compare, on a quantitative basis, either individuals or groups with regard to the amount of improvement, rate of improvement, and the predicted ultimate threshold that would result from infinite practice.

Variability

There are large differences in the benefits of practice between individuals and as a function of velocity. An analysis of the variability of each data point shown in Fig. 1 reveals an average standard deviation of the means of 37% (range = 32-40%) and 47% (range = 16-55%) for velocities of 20 deg and 110 deg/sec, respectively. Average stan-

standard deviation of the means were 15% (range = 5-21%) and 37% (range = 14-64%) for the 20 poorest and 20 best learners, respectively. Based on the data obtained from the 200 Naval aviation cadets, the split-half reliability was

found to be 0.99. The test-retest reliability based on 120 of the original group of 200 cadets, after an elapsed time of 10 months, was 0.65 and 0.87 for the *a* and *b* parameters of Eq. 1.

Constraints

- All data collected with observer's head in fixed position.
- All subjects were male Naval personnel already screened for their medical condition.
- Many factors (such as spectral composition of illumination, viewing distance, exposure time, light level, and direction of movement) may affect dynamic acuity and should be considered when applying these data under different conditions (CRefs. 1.617, 1.619).

- Dynamic visual acuity declines with advancing age. If the *a* and *b* parameters (Eq. 1) of an older group aged 40-50 yr are expressed as a percentage of those of a group aged 20-30 yr, the *a* parameter varies by 113%, whereas the *b* parameter varies by only 50%. Age-related effects are associated primarily with the dioptics of the eye rather than with the function of the oculomotor system.

Key References

*1. Miller, J. W., & Ludvigh, E. (1962). The effects of relative motion on visual acuity. *Survey of Ophthalmology*, 7, 83-116.

Cross References

1.617 Visual acuity with target motion: effects of target velocity and target versus observer movement;
1.618 Visual acuity with target motion: effect of target velocity and orientation;

1.619 Visual acuity with target motion: effect of direction of movement and luminance level;

1.620 Visual acuity with target motion: effect of direction of movement and target orientation;

1.621 Visual acuity with target motion: effect of anticipation time and exposure time;

1.939 Factors affecting smooth pursuit eye movements

1.623 Visual Acuity and Contrast Sensitivity: Effect of Age

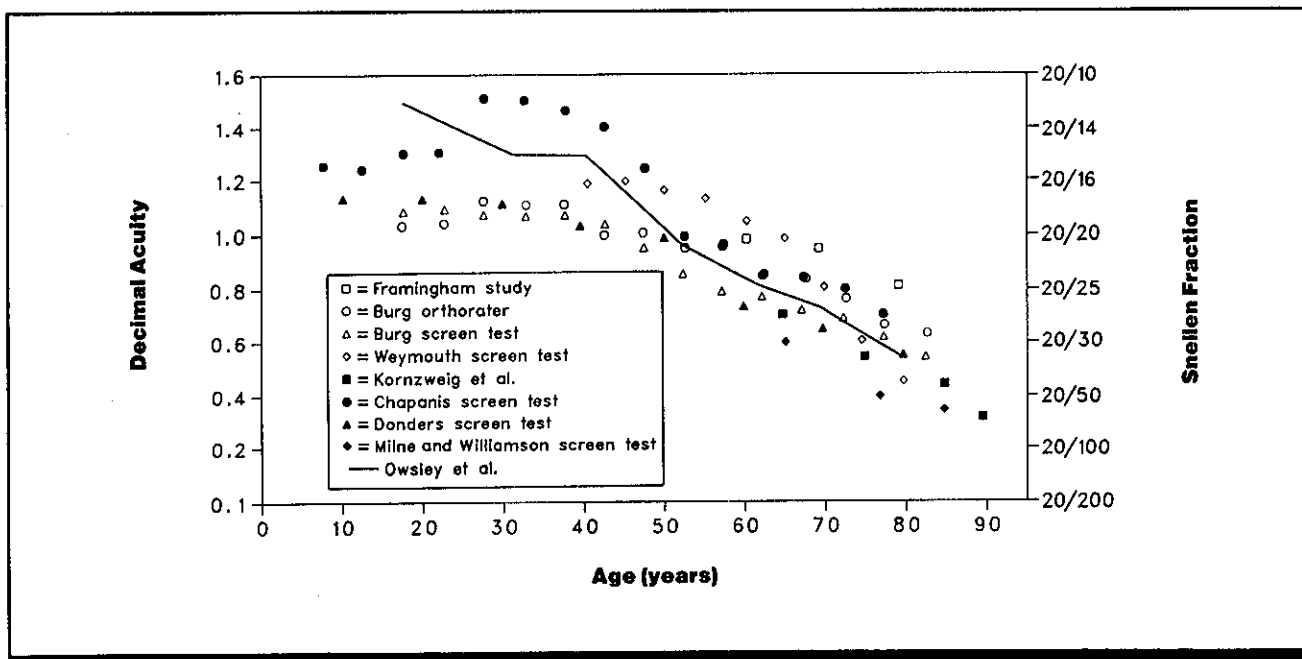

Figure 1. Visual acuity as a function of age. The results of several studies relating acuity to age are presented. Decimal acuity is shown on the left-hand ordinate and the equivalent Snellen acuity on the right. (Decimal acuity is the reciprocal of the smallest resolvable target detail in minutes of arc of visual angle; Snellen acuity gives the furthest distance at which a standard set of letters could be read compared to the furthest distance at which the letters could be read by an observer with normal vision.) Solid line shows the results from Ref. 1 gathered using the procedure described in the text; for comparison, symbols show results from a number of other studies using various acuity tests. (From Ref. 2)

Key Terms

Age; contrast sensitivity; spatial resolution; visual acuity

General Description

In otherwise healthy individuals, aging leads to decline in visual performance as measured by standard acuity or contrast sensitivity measures. Decline generally begins after age 40 and is continuous throughout the lifespan. Interestingly, acuity is typically better than 20/20 when measured in individuals with normal or corrected-to-normal vision under age 40 (Fig. 1, Ref. 1). Acuity declines to 20/30 around age 75 (Ref. 1). Contrast sensitivity functions may reveal aspects of visual function that are not detected using standard acuity measures. After age 40, the contrast sensitivity function shows a decline at spatial frequencies >2 cycles/deg throughout the lifespan. Peak sensitivity shifts to lower spatial frequencies during this period. There is no loss in sensitivity to lower spatial frequencies with age.

These measured losses are largely explained by changes in the lens and pupil, but neural changes cannot be ruled out.

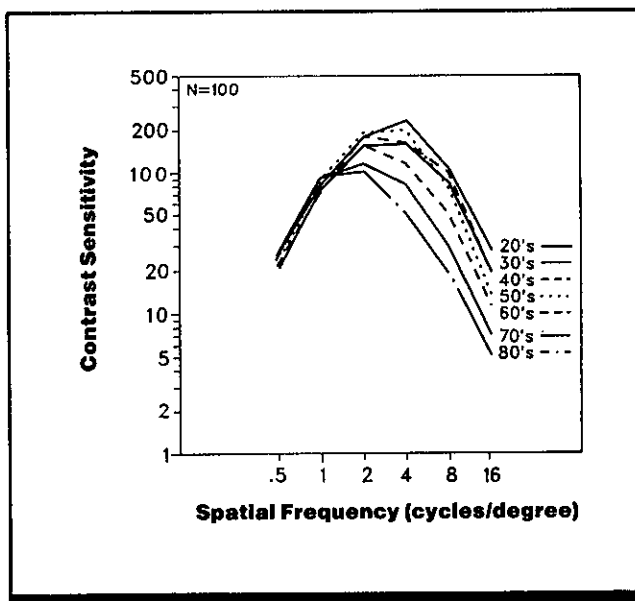

Figure 2. Contrast sensitivity as a function of age. (From Ref. 1)

Methods

Test Conditions

• Acuity: targets were Sloan letters (Ref. 3) tested at 3-m distance, 0.9 contrast, with average luminance of 87.6 cd/m² for older observers (60+) and 200 cd/m² for younger observers; acuity testing for older and younger observers took place at different sites

• Contrast sensitivity: measurements made using Optronix Vision Tester; stationary vertical sine-wave gratings (bar patterns) 0.5, 1.0, 2.0, 4.0, 8.0, and 16.0 cycles/deg presented on display measuring 2.4 × 5.5 deg at 3-m distance; mean screen luminance: 103 cd/m²; grating contrast defined as $(L_{\max} - L_{\min}) / (L_{\max} + L_{\min})$ where L_{\max} and L_{\min} are the luminances of the brightest and darkest parts of the pattern, respectively

Experimental Procedure

• Acuity measured by standard eye exam; contrast sensitivity determined by staircase procedure
 • Independent variables: grating spatial frequency, age of subject
 • Dependent variables: acuity, defined as minimum angle of resolution; contrast threshold, defined as geometric means of eight reversals of staircase (contrast sensitivity, or 1/threshold, is graphed in Fig. 2)

• Observer's task: acuity: read letters from chart; contrast sensitivity: indicate when grating pattern first became visible or first became invisible as grating increased or decreased in contrast
 • 91 observers, ages 19-87 yr (31 observers <60 yr and 60 observers >60 yr); all observers >60 yr were given a thorough eye examination and those with eye problems were excluded

Experimental Results

• Visual acuity declines with age (Fig. 1).
 • Contrast sensitivity shows losses with increasing age at higher spatial frequencies (Fig. 2). This decrease is significant for all spatial frequencies >2 cycles/deg for observers

>40 yr ($p < 0.05$). For contrast sensitivity measurements at 8 cycles/deg, standard error of the mean was 0.05 for 20-year-olds and 0.13 for 70-year-olds.

• Peak contrast sensitivity shifts to lower spatial frequencies with increasing age.

Constraints

• For both acuity and contrast sensitivity measurements, older observers were selected to exclude those with eye problems that are more common in this population. Therefore, these data do not reflect typical, unselected observers.

• Many factors (such as luminance level, pupil size, and target motion) influence visual acuity and contrast sensitivity (CRefs. 1.603, 1.628).

Key References

*1. Owsley, C., Sekuler, R., & Siemsen, D. (1983). Contrast sensitivity throughout adulthood. *Vision Research*, 23, 689-699.

2. Pitts, D. G. (1982). The effects of aging on selected visual functions: Dark adaptation, visual acuity, stereopsis and brightness contrast. In R. Sekuler, D. Kline, & K. Kismukes (Eds.), *Aging in human visual functions*. New York: Liss.

3. Sloan, L. L. (1959). New test charts for the measurement of visual acuity at far and near distances. *American Journal of Ophthalmology*, 48, 807-813.

Cross References

1.603 Factors affecting visual acuity;

1.628 Factors affecting contrast sensitivity for spatial patterns;

Handbook of perception and human performance, Ch. 7, Sect. 4.3

1.624 Factors Affecting Detection of Spatial Targets

Key Terms

Exposure duration; light adaptation; luminance; spatial summation; target detection; target motion; temporal summation; visual field location

General Description

Many factors, such as target size, exposure duration, location in the visual field, orientation, etc., affect the luminance threshold of targets (minimum target luminance at which target can be detected on 50-75 percent of trials). The table summarizes the effects of several important factors on

target detection and cites sources of more detailed information. These results pertain to spatially discrete targets, which are usually spots of light (see CRef. 1.305 for a discussion of additional factors affecting sensitivity to light). Results obtained with spatially periodic targets are related, but differ in some respects (CRef. 1.628).

Factor	Effect on Luminance Threshold	References
Target size	<p>For small light spots, threshold decreases as target area increases (spatial summation); threshold is determined by total light energy; that is, $\text{area} \times \text{luminance} = \text{constant}$, a relationship known as Ricco's law. For light spots larger than some critical size (which varies from ~6 min arc to ~1.0 deg depending on viewing conditions), luminance threshold is independent of area</p> <p>Area over which spatial summation occurs is generally larger at greater distances from fixation. Actual value of the critical size (size below which Ricco's law holds) depends on exposure duration</p> <p>The critical size decreases with increase in the level of illumination to which observer is adapted</p> <p>Visibility of rectangular targets increases as the longer dimension (length) is increased, up to ~40-50 min arc of visual angle. Increases in the shorter dimension (width) play a role in visibility only when width is less than ~5 min arc. These effects are independent of target orientation</p>	<p>Ref. 4; CRefs. 1.307, 1.308, 1.403</p> <p>Ref. 7</p> <p>Ref. 2</p> <p>CRef. 1.625</p>
Target duration	<p>For small, briefly presented targets, threshold decreases as exposure time increases (temporal summation); threshold depends on total light energy, that is, $\text{luminance} \times \text{duration} = \text{constant}$, a relationship known as Bloch's Law. For durations longer than ~100 msec, this relation no longer holds, and threshold is unaffected by increases in target exposure time</p>	<p>Ref. 4; CRef. 1.402</p>
Interaction of size and duration	<p>Effects are additive within parameters of Ricco's and Bloch's laws. No simple relationship outside these parameters; target location in visual field is relevant.</p>	<p>Ref. 2</p>
Target orientation	<p>Elongated targets have lower thresholds at horizontal and vertical orientations than at oblique orientations, a phenomenon known as the oblique effect</p>	<p>Ref. 1</p>
Target velocity	<p>For short excursion distances and brief durations, luminance threshold is independent of target for long path lengths and high velocities (50-2000 deg/sec), luminance threshold increases with increased target velocity</p>	<p>Ref. 6</p>
Light adaptation	<p>Threshold for light spots increases with increasing light adaptation</p>	<p>Ref. 2; CRef. 1.626</p>
Location in the visual field	<p>When observer is light-adapted, luminance threshold increases with increasing target distance from fixation. This effect is more pronounced for small targets than for large ones. When observer is dark-adapted, luminance threshold is lowest ~15 deg from fixation and then increases with increasing distance from fixation; threshold is high in the fovea</p>	<p>Refs. 3, 8; CRefs. 1.306, 1.307</p>
Spatial uncertainty	<p>For faint or brief targets uncertainty about the spatial location or the size of the target leads to decrements in detection performance</p>	<p>CRef. 1.627</p>

Applications

Occupational and training environments in which the detectability of small spatial targets must be maximized.

Constraints

- There may be interactions among these factors, but such interactions generally have not been studied.
- Recent evidence indicates that rapid selective adaptation may affect measured thresholds in typical experiments from which results in the table are derived (Ref. 5).

Key References

1. Appelle, S. (1972). Perception and discrimination as a function of stimulus orientation: The "oblique effect" in man and animals. *Psychological Bulletin*, 78, 266-278.

2. Barlow, H. B. (1958). Temporal and spatial summation in human vision at different background intensities. *Journal of Physiology*, 141, 337-350.

3. Bartlett, N. R. (1965). Dark adaptation and light adaptation. In C. H. Graham (Ed.), *Vision and visual perception* (pp. 185-207). New York: Wiley.

4. Bartlett, N. R. (1965). Thresholds as dependent on some energy relations and characteristics of the subject. In C. H. Graham (Ed.), *Vision and visual perception* (pp. 154-184). New York: Wiley.

5. Frome, F. S., MacLeod, D. I. A., Buck, S. L., & Williams, D. R. (1981). Large loss of visual sensitivity to flashed peripheral targets. *Vision Research*, 21, 1323-1328.

6. Graham, C. H. (1965). Perception of movement. In C. H. Graham (Ed.), *Vision and visual perception* (pp. 575-588). New York: Wiley.

7. Graham, C. H., Brown, R. H., & Mote, F. A. (1939). The relation of size of stimulus and intensity in the human eye. I. Intensity thresholds for white light. *Journal of Experimental Psychology*, 24, 555-573.

8. Wilson, H. R., & Giese, S. C. (1977). Threshold visibility of frequency gradient patterns. *Vision Research*, 17, 1177-1190.

Cross References

1.305 Factors affecting sensitivity to light;

1.306 Absolute sensitivity to light: effect of visual field location;

1.307 Absolute sensitivity to light:

effect of target area and visual field location;

1.308 Spatial summation of light energy;

1.402 Brightness difference threshold: effect of background luminance and duration of luminance increment;

1.403 Brightness difference threshold: effect of background luminance and target size;

1.625 Target detection: effect of target spatial dimensions;

1.626 Target detection: effect of prior exposure (adaptation) to a target of the same or different size;

1.627 Target detection: effect of spatial uncertainty;

1.628 Factors affecting contrast sensitivity for spatial patterns;

1.625 Target Detection: Effect of Target Spatial Dimensions

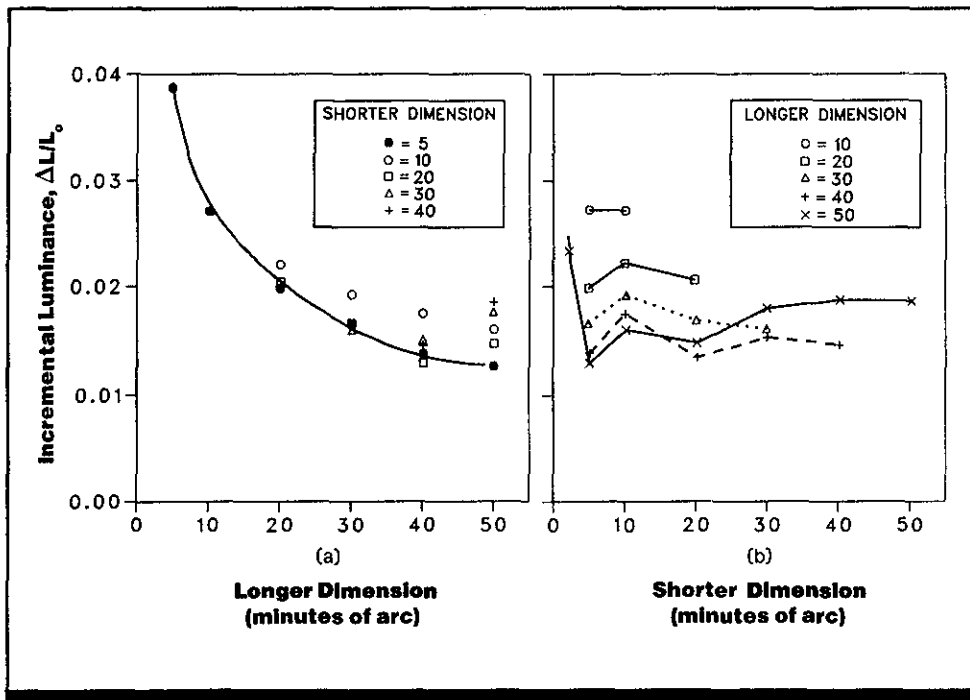

Figure 1. Visibility threshold (expressed as luminance increment above background luminance necessary for detection), as a function of (a) longer and (b) shorter dimensions of rectangular stimuli. (From *Handbook of perception and human performance*, based on data from Ref. 2)

Key Terms

Size; spatial summation; target detection

General Description

Visibility of rectangular targets increases as the longer dimension (length) is increased, up to ~ 40 - 50 min arc of visual angle. Increases in the shorter dimension (width) play a role in visibility only when width is less than ~ 5 min arc. These effects are independent of target orientation.

Applications

Displays and environments where visibility of targets must be maximized.

Methods

Test Conditions

- Test targets: uniformly illuminated rectangles of light superimposed on 10×15 deg background of 250 cd/m^2
- Targets generated using high-contrast photographic transparencies

- Luminance computer-controlled using **neutral-density filter**
- Targets presented **monocularly** in **Maxwellian view** with 2-mm artificial pupil; 1 sec exposure time

Experimental Procedure

- Signal detection procedure; blocked design with several sets of test target dimensions per session

- 1/3 of trials presented in all sessions were noise (no target)
- Independent variables: length and width of test target
- Dependent variable: luminance threshold, defined as luminance that yields area under receiver operating characteristic (ROC) curve of 0.8, estimated by regression

(comparable to 0.8 proportion correct in two-alternative forced choice procedure)

- Observer's task: judge whether a target was present, rating each trial on a six-point scale according to estimate of probability that a test target was presented
- Data for 4 observers are shown in Fig. 1

Experimental Results

- Visibility of a rectangular target increases as the longer dimension is increased up to ~40 min arc.
- If the longer dimension is increased above 40 min, visibility increases for narrow targets (5 or 10 min) and decreases for wider targets.
- Increases in the shorter dimension produce increases in visibility only when the shorter dimension is between 2.5 and 5 min wide.
- As the shorter dimension increases from 5-50 min, visibility shows no consistent trend for targets whose longer dimension is <50 min. For targets whose longer dimension is 50 min, there is a slight trend for visibility to decrease slightly as width increases from 5-50 min.

- The orientation of the target has no influence on the effects produced by varying the size of the longer or shorter target dimensions (data not shown).

Variability

52% of the measures showed standard errors between 0.01 and 0.02 log units; 95% of the standard errors fell below 0.03 log units.

Repeatability/Comparison with Other Studies

Reference 1, using few targets wider than 5 min, found that visibility was determined by perimeter, rather than by the longer dimension.

Constraints

- Many factors influence target detection and should be considered in applying these results under different conditions (CRef. 1.624).

Key References

1. Lamar, E. S., Hecht, S., Hendley, C. D., and Shlaer, S. (1948). Size, shape, and contrast in detection of targets by day-

light vision. II. Frequency of seeing and the quantum theory of cone vision. *Journal of the Optical Society of America*, 38, 741-755.

*2. Thomas, J. P. (1978). Spatial summation in the fovea: Asymmetrical effects of longer and shorter dimensions. *Vision Research*, 18, 1024-1029.

Cross References

1.624 Factors affecting detection of spatial targets;

Handbook of perception and human performance, Ch. 7, Sect. 2.1

1.626 Target Detection: Effect of Prior Exposure (Adaptation) to a Target of the Same or Different Size

Key Terms

Selective adaptation; size; spatial filtering; target detection

General Description

Prolonged exposure (**adaptation**) to circular targets decreases the visibility of subsequently presented targets of the same size as the adapting target. The more the target and the adapting stimulus differ in size, the less visibility is affected.

Applications

Displays and viewing environments where the visibility of low-contrast targets must be maximized.

Methods

Test Conditions

- Monocular test disks of 5-50 min arc of visual angle flashed in Maxwellian view against background 15 deg in diameter and of luminance 72 cd/m² for 1 sec
- In adaptation conditions, adapting targets of 5-50 min arc at a luminance of 1.0 log unit above their own threshold presented for 3 min prior to each block of 100 test trials; adaptation refreshed by 2-sec presentation prior to each trial
- Trial consisted of 1-sec presentation of test target or nothing presented for noise trials
- Adapting and test targets generated with incandescent light; 3-mm artificial pupil used

Experimental Procedure

- Signal detection procedure; blocked design
- Independent variables: diameter of test stimulus, diameter of adapting stimulus
- Dependent variable: log difference in threshold with and without prior adaptation, where threshold is defined as luminance required to obtain area under receiver operating characteristic (ROC) curve of 0.8 (this is equivalent to 80% correct threshold using two-alternative forced-choice procedure)
- Observer's task: maintain steady fixation during adaptation; during test trials; rate confidence in detecting the presence of the test target on a specific scale (often "1" to "5," but not specified)
- 2 experienced, practiced observers with corrected-to-normal acuity

Experimental Results

- Threshold for a circular target is elevated by prior exposure to an adapting disk when test and adapting targets are of similar diameter.
- Threshold difference between adapted and unadapted conditions diminishes as the difference between test and adaptation target sizes increases. Threshold elevation falls to about half its maximum when test and adapting targets differ by ~10-15 min arc of visual angle in size.
- The shapes of the "tuning" functions, after normalization, are similar for all adapting target sizes (Fig. 2).

Variability

Error bars in Fig 1. indicate ± 1 standard error of the threshold difference in log units.

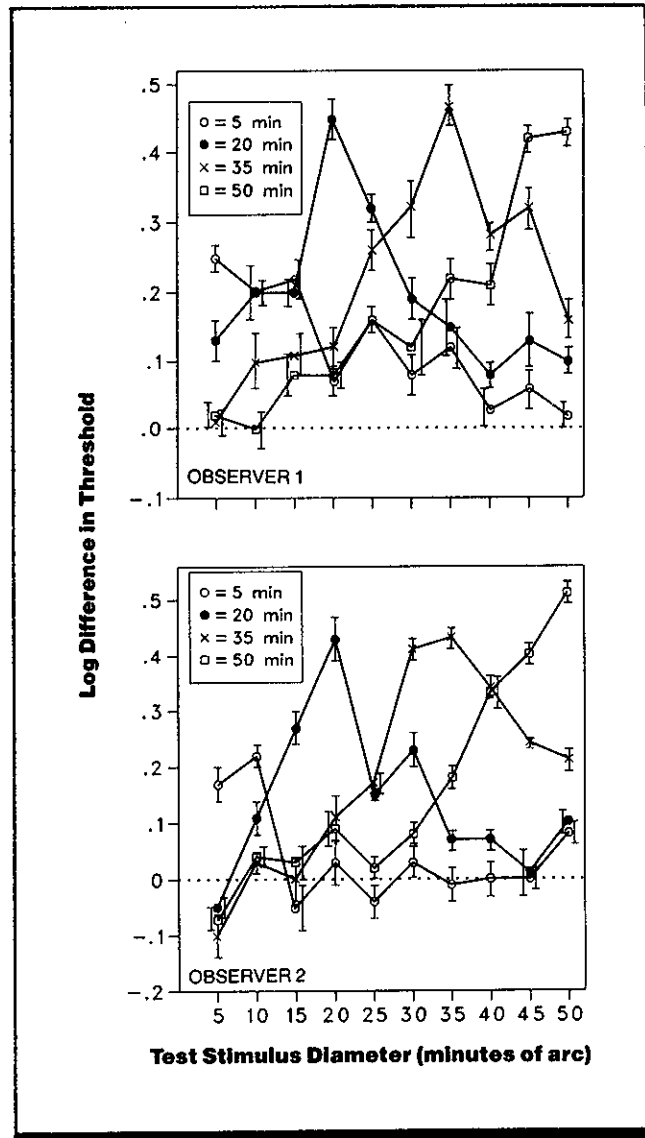

Figure 1. The difference between log visibility (threshold luminance) of a circular test target with and without prior adaptation. Each curve is for a different adapting target diameter. (From Ref. 1)

Repeatability/Comparison with Other Studies

Similar size-related effects occur when the test and adapting targets are bar patterns (CRef. 1.651). Selective adaptation is also found for bar orientation (CRef. 1.652).

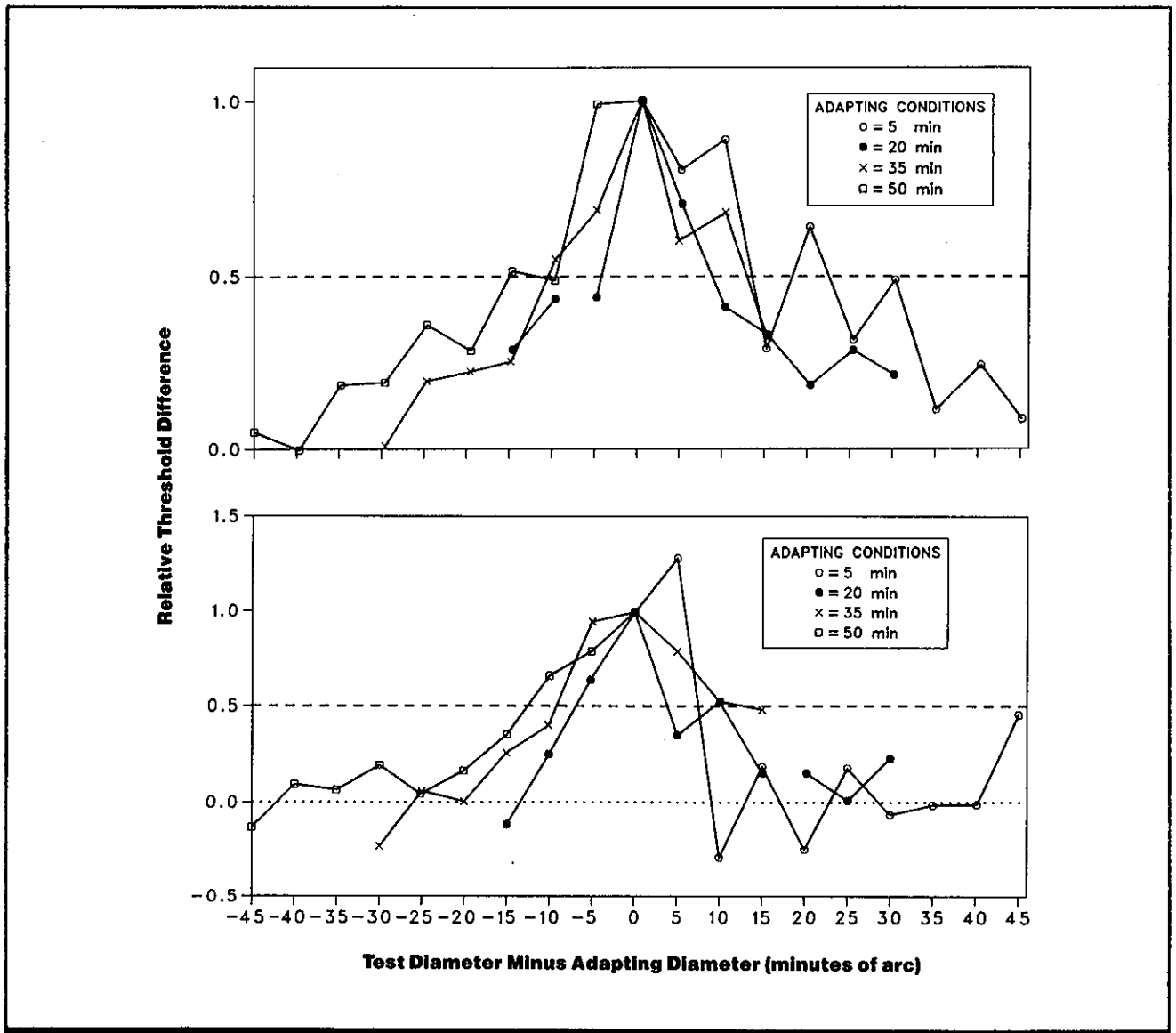

Figure 2. Data of Fig. 1 shown as a proportion of the threshold difference obtained when adapting targets and test targets are the same size and plotted as a function of the difference between test and adapting target diameters. Each curve is for a different adapting target diameter. (From Ref. 1)

Constraints

- Adaptation effects with aperiodic stimuli such as these are greatly diminished when the eye is free to move.
- Adaptation tuning curves obtained with gratings generally show more similar shapes on a log spatial frequency scale (CRef. 1.651).

- Shifts in the apparent size of a target can also occur following adaptation.
- Increasing the contrast of the adapting target increases the magnitude of the effects.
- Many factors (such as luminance level, orientation, and visual field location) affect target detectability and must be considered in applying these results under different viewing conditions (CRefs. 1.305, 1.624).

Key References

*1. Bagrash, F. M. (1973). Size-selective adaptation: Psychophysical evidence for size-tuning and the

effects of stimulus contour and adapting flux. *Vision Research*, 13, 575-598.

2. Thomas, J. P. (1970). Model of the function of receptive fields in human vision. *Psychological Review*, 77, 121-134.

Cross References

1.305 Factors affecting sensitivity to light;

1.401 Brightness difference threshold: effect of background luminance;

1.402 Brightness difference threshold: effect of background luminance and duration of luminance increment;

1.403 Brightness difference threshold: effect of background luminance and target size;

1.624 Factors affecting detection of spatial targets;

1.628 Factors affecting contrast sensitivity for spatial patterns;

1.651 Spatial frequency (size) adaptation;

1.652 Orientation-selective effects on contrast sensitivity;

Handbook of perception and human performance, Ch. 7, Sect. 2.2

1.627 Target Detection: Effect of Spatial Uncertainty

Key Terms

Position uncertainty; spatial uncertainty; target detection

General Description

When an observer's task is to detect a faint or briefly presented target, uncertainty about the spatial location of the target or the size or **spatial frequency** of the target leads to decrements in detection performance (Refs. 2, 4, 5, 6, 9). Uncertainty about target **contrast** does not lead to performance decrement (Ref. 5).

Figure 1a shows a typical arrangement for investigating the effect of uncertainty of spatial position. The bar pattern can appear in any of the 16 positions on each trial, or no target at all may be presented. Figure 1b shows a target configuration for studying the effects of spatial frequency uncertainty. A number of possible sources of performance decrement arise under these conditions. (1) The target may not be viewed with the **fovea** (the central part of the retina where activity is greatest). Thus, detection performance for some targets, especially high-frequency targets (patterns with narrow bars) as shown in Figure 1a, will decline if the observer is not looking in the right place when the target appears. To control for such effects, performance with position uncertainty can be compared with performance when the location of the possible target is cued, but eye movements are not permitted (Ref. 5). (2) If target positions or target spatial frequencies are sufficiently separated so that the different target alternatives stimulate independent detection mechanisms in the visual system, then uncertainty causes effects associated with monitoring multiple visual mechanisms. Essentially, the decrement in performance can be interpreted as an increasing possibility of mistaking sensory noise for target when target energy is faint. For example, for each spatial location monitored, the observer must decide whether the activity in the visual system associated with that location represents a signal (target) or noise. As the number of locations monitored increases, the probability of mistaking noise for a signal increases. Figure 2 shows how detection performance declines as the number of possible stimuli increases for different signal-to-noise ratios (Ref. 7). (3) When target duration is brief and information channels must be examined serially (as when attention is implicated in the task), the neural response to the target generated in the visual system may fade before the appropriate channel is examined, leading to more dramatic decrements in performance than those predicted by **signal detection theory**. Such effects are evident for spatial position uncertainty when the target is brief and of low energy (Ref. 1). These effects have not been convincingly demonstrated for the spatial frequency uncertainty with brief target presentation (Refs. 4, 5, 6).

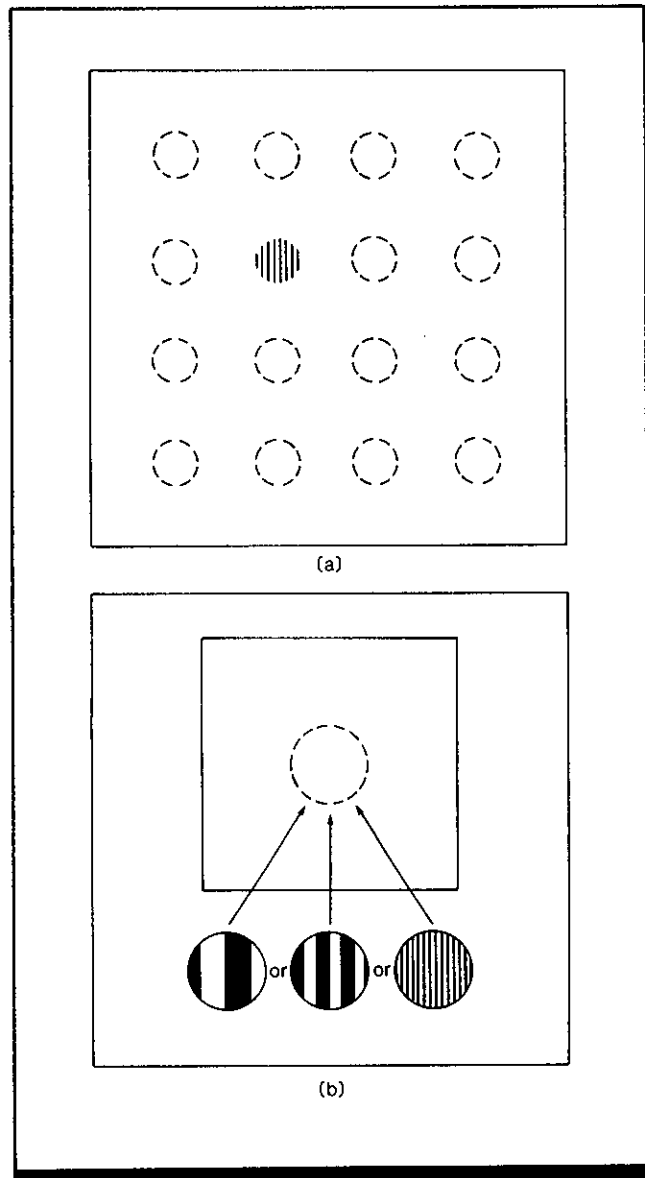

Figure 1. Examples of stimulus uncertainty. (a) Uncertainty with respect to spatial position. The task of the observer is to detect the grating, which may appear in any one of the 16 positions indicated. (b) Uncertainty with respect to spatial frequency. The task of the observer is to detect the grating, which always appears in the location indicated by the broken circle. However, the grating may have any one of three different spatial frequencies. (From *Handbook of perception and human performance*)

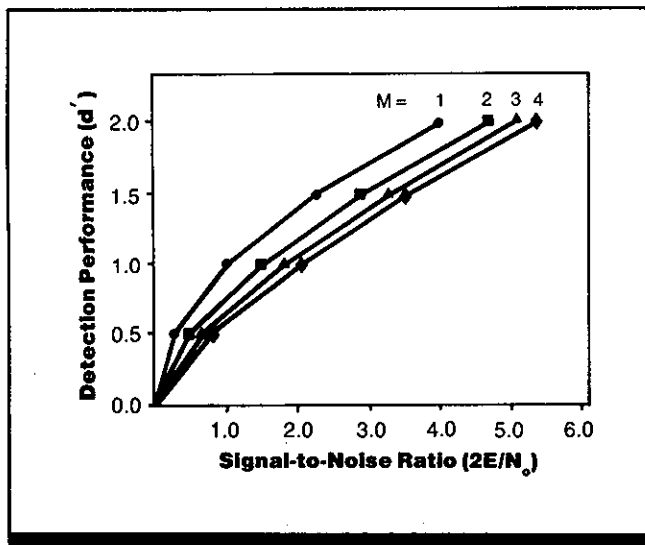

Figure 2. Detection of signals by an ideal observer. The task of the observer is to detect any one of many possible signals (e.g., different target locations or spatial frequencies) against a background of noise (where only one of the signal alternatives can occur on any given trial). The figure indicates how the performance of an ideal observer depends upon the number of possible signals (M). The signal-to-noise ratio is expressed in terms of signal and noise energies (i.e., square of the contrast). The figure expresses the following approximation, which is discussed in Ref. 7, pp. 172-173:

$$2E/N_0 = \ln[1 + M(\exp(d'^2) - 1)]$$

where E is the energy of each signal, N_0 is the noise power density of the noise, and d' is a measure of the observer's sensitivity (for a definition, CRef 7.420). Performance at all signal levels progressively decreases as the number of possible signals increases from 1 to 4.

Applications

Displays and environments in which detection of faint signals must be maximized.

Constraints

- Many factors in addition to uncertainty affect target detection (CRef. 1.624).

Key References

1. Bashinski, H. S., & Bacharach, V. R. (1980). Enhancement of perceptual sensitivity as the result of selectively attending to spatial location. *Perception & Psychophysics*, 28, 241-248.
2. Cohn, T. E., & Lasley, D. J. (1974). Detectability of a luminance increment: Effect of spatial uncertainty. *Journal of the Optical Society of America*, 64, 1715-1719.
3. Cohn, T. E., & Wardlaw, J. C. (1985). Effect of large spatial uncertainty of foveal luminance increment detectability. *Journal of the Optical Society of America A*, 2, 820-825.
4. Davis, E. T., & Graham, N. (1981). Spatial frequency uncertainty effects in the detection of sinusoidal gratings. *Vision Research*, 21, 705-712.
5. Davis, E. T., Kramer, P., & Graham, N. (1983). Uncertainty about spatial frequency, spatial position, or contrast of visual patterns. *Perception & Psychophysics*, 33, 20-28.
6. Graham, N., Robson, J. G., & Nachmias, J. (1978). Grating summation in fovea and periphery. *Vision Research*, 18, 815-826.
7. Green, P. M., & Swets, J. A. (1974). *Signal detection theory and psychophysics*. New York: Kreiger.
8. Lasley, D. J., & Cohn, T. E. (1981). Detection of a luminance increment: Effect of temporal uncertainty. *Journal of the Optical Society of America*, 71, 845-850.
9. Swensson, R. G., & Judy, P. F. (1981). Detection of noisy visual targets: Models for the effects of spatial uncertainty and signal to noise ratio. *Perception & Psychophysics*, 29, 521-534.

Cross References

- 1.624 Factors affecting detection of spatial targets;
 7.420 Signal detection theory;
Handbook of perception and human performance, Ch. 7, Sect. 1.3

1.628 Factors Affecting Contrast Sensitivity for Spatial Patterns

Key Terms

Contrast sensitivity; flicker; luminance; pattern detection; size; spatial orientation; temporal frequency; visual field location

General Description

The *contrast threshold* is the minimum luminance **contrast** between lightest and darkest parts of a spatial pattern that will allow the observer to detect the pattern on some given percentage of trials (i.e., will allow the observer to distinguish the pattern from a uniformly lit field of the same average luminance as the pattern). *Contrast sensitivity* is the reciprocal of the contrast threshold. In current visual re-

search, contrast sensitivity is most frequently measured using **sine-wave gratings** (bar patterns), but other targets, such as single bars or circular spots of light, have also been employed. The detection of low-contrast patterns depends on a variety of factors. The table lists several major factors affecting contrast sensitivity, briefly describes the direction and magnitude of their effects, and cites sources that provide additional information.

Applications

Displays and environments in which the detection of low-contrast targets must be maximized.

Factor	Effect on contrast sensitivity	Reference
Accommodation (eye focus)	Errors in accommodation (optical focus of the eye) result in a blurred retinal image and degrade contrast sensitivity for bar patterns (sine-wave gratings). Focus errors attenuate the visibility of high spatial frequencies (fine patterns) more than low ones (coarse patterns)	CRef. 1.639
Adaptation	Contrast sensitivity for a bar pattern (sine-wave grating) may be affected by prior adaptation (prolonged exposure) to a similar bar pattern. Contrast threshold for detection shows a five-fold elevation for test gratings whose spatial frequency (bar size) is close to that of the adapting grating. Threshold elevation decreases with increasing difference in test grating and adapting grating spatial frequencies	CRef. 1.651
Border gradients	Contrast sensitivity for a sine-wave grating (bar pattern) is greatest (i.e., contrast thresholds are lowest) at spatial frequencies between 1 cycle/deg and 3 cycles/deg; sensitivity is lower at lower and higher spatial frequencies. At low spatial frequencies, contrast thresholds are determined in part by the luminance gradient between adjacent light and dark bars, which is related to the effect of blurring the border between light and dark halves of split field (an edge). For a single edge, contrast threshold is independent of the border gradient when gradients are steep (equivalent to higher spatial frequencies) and thus blur is small	CRef. 1.642
Location in the visual field (retinal eccentricity)	Sensitivity is generally highest in the center of the visual field and falls off approximately linearly with increasing eccentricity. Sensitivity declines more rapidly with increasing spatial frequency	Ref. 4; CRef. 1.635
Masking	When a masking bar pattern (sine-wave grating) is presented simultaneously with a test grating, minimum pattern contrast necessary to detect the test grating is increased when the spatial frequency (bar size) of the masking grating is within an octave of the frequency of the test grating. When the spatial frequencies of the mask and test grating are greater than 1-2 octaves apart, the presence of the mask can lower the detection threshold (i.e., increase sensitivity) for the test grating. This effect is asymmetrical and is more pronounced for gratings above the mask frequency than for gratings below it	CRef. 1.650

Factor	Effect on contrast sensitivity	Reference
Mean luminance	As mean luminance increases, overall sensitivity increases and then levels off above ~ 100 cd/m ² . For low luminance ($< \sim 0.002$ cd/m ²), sensitivity to low spatial frequencies is about the same as for middle-range spatial frequencies. As luminance increases, relative sensitivity to low spatial frequencies drops, although overall sensitivity increases. Also, the spatial frequency of peak sensitivity increases as luminance increases	Ref. 5; CRef. 1.631, 1.632, 1.633
Number of luminance cycles visible (for periodic patterns)	Given a sufficient number of luminance cycles, sensitivity is independent of the number of cycles presented; as the number of cycles is reduced below this critical number, sensitivity falls off. The critical number of cycles increases with increasing mean luminance Dependence of contrast sensitivity on the number of cycles is often confounded by edge effects at the edges of display masks; cycle-dependent effects may be negligible after correcting for these edge effects	Ref. 1; CRef. 1.631
Orientation	Sensitivity is higher for vertical and horizontal orientations than for oblique orientations. This oblique effect is more pronounced for high than for low spatial frequencies	Ref. 2; CRef. 1.634
Pupil size	Contrast sensitivity for a sine-wave grating (bar pattern) is greatest with a pupil size of 2 mm. An eye with a 2-mm pupil has an optical attenuation in agreement with a diffraction-limited system (CRef. 1.213). With increasing pupil size, the performance of the optics deviates progressively from a perfect optical system. For all pupil sizes, at an average target luminance of 100 cd/m ² , contrast sensitivity for sine-wave gratings reaches a peak at a spatial frequency of ~ 5 -9 cycles per deg and declines rapidly at higher spatial frequencies	CRef. 1.638
Size of viewing field	Contrast sensitivity for sine-wave gratings (bar patterns) is slightly better with a larger (rather than smaller) viewing field for gratings less than ~ 3 -4 cycles/deg. For both field sizes, contrast sensitivity increases as spatial frequency increases up to 2-4 cycles/deg; sensitivity then decreases as spatial frequency increases	CRef. 1.629
Spatial frequency	Middle-range spatial frequencies (~ 4 -8 cycles/deg) are easiest to detect, whereas higher frequencies require more contrast; depending on viewing conditions, sensitivity for lower frequencies may be similar to that for middle-range frequencies or sensitivity may be less Sensitivity over the visible spectrum may vary as much as ~ 60 dB	Ref. 5; CRefs. 1.624, 1.649
Target	A moving target is easier to detect than a stationary target with either foveal or peripheral viewing but the advantage for the moving target is greater for peripheral viewing. Contrast threshold for moving targets varies little as target distance from fixation increases; however, the contrast required to detect a stationary target increases the further the target is from fixation	CRef. 1.637
Target shape and illumination level	As background luminance increases, the minimum contrast needed to detect a target's presence or to judge its detail decreases. The configuration of the target affects the steepness of the decline in threshold with background luminance as well as its absolute value. More complex targets tend to have lower contrast thresholds	CRef. 1.643
Temporal Frequency (flicker rate)	At moderate to high flicker rates, (greater than ~ 6 Hz), temporal modulation of contrast leads to a uniform reduction of contrast sensitivity with increasing temporal frequency (~ 0.5 log unit per octave temporal frequency). At low flicker rates (less than ~ 6 Hz), sensitivity to low spatial frequencies is selectively reduced	Ref. 3 CRefs. 1.501, 1.508
Uncertainty	For faint or brief targets, uncertainty about the spatial location or size of a target leads to decrements in detection performance (i.e., decreased sensitivity)	CRef. 1.650

Constraints

- These results apply to conditions where the signal is known; uncertainty reduces contrast sensitivity (CRef. 1.627).
- Absolute contrast sensitivity varies widely among observers and differs with psychophysical testing method.

Key References

1. Hoekstra, J., Van der Goot, D. P. J., Van der Brink, K. G., & Bilsen, A. (1974). The influence of the number of cycles upon the visual contrast threshold. *Vision Research*, 14, 355-358.

2. Mitchell, D. E., & Wilkinson, F. (1974). The effect of early astigmatism on the visual resolution of gratings. *Journal of Physiology*, 243, 739-756.

3. Robson, J. G. (1966). Spatial and temporal contrast sensitivity functions of the visual system. *Journal of the Optical Society of America*, 56, 1141-1142.

4. Robson, J. G., & Graham, N. (1981). Probability summation and regional variation in contrast sensitivity across the visual field. *Vision Research*, 21, 409-418.

5. van Nes, F. L., & Bouman, M. A. (1967). Spatial modulation

transfer in the human eye. *Journal of the Optical Society of America*, 57, 401-406.

6. van der Wildt, G. J., & Waarts, R. G. (1983). Contrast detection and its dependence on the presence of edges and lines in the stimuli field. *Vision Research*, 23, 821-830.

Cross References

- 1.106 Conversion of scene luminance to retinal illuminance;
- 1.213 Diffraction of light in optical systems;
- 1.305 Factors affecting sensitivity to light;
- 1.501 Factors affecting sensitivity to flicker;
- 1.508 Flicker sensitivity: effect of target spatial frequency;

- 1.624 Factors affecting detection of spatial targets;
- 1.627 Target detection: effect of spatial uncertainty;
- 1.629 Contrast sensitivity: effect of field size;
- 1.631 Contrast sensitivity: effect of number of luminance modulation cycles and luminance level;
- 1.632 Contrast sensitivity: effect of luminance level (foveal vision);

- 1.633 Contrast sensitivity: effect of luminance level (peripheral vision);
- 1.634 Contrast sensitivity: effect of target orientation;
- 1.635 Contrast sensitivity: effect of target visual field location for bar patterns of varying size;
- 1.637 Contrast sensitivity: effect of target motion;
- 1.638 Contrast sensitivity: effect of pupil size;
- 1.639 Contrast sensitivity: effect of focus errors;

- 1.642 Contrast sensitivity: effect of border gradient;
- 1.643 Contrast sensitivity: effect of target shape and illumination level;
- 1.649 Spatial frequency (size) discrimination: effect of contrast;
- 1.650 Spatial frequency (size) masking;
- 1.651 Spatial frequency (size) adaptation

Notes

1.629 Contrast Sensitivity: Effect of Field Size

Key Terms

Contrast sensitivity; modulation transfer function; pattern detection; size

General Description

Contrast sensitivity for sine-wave gratings (bar patterns) is slightly better with a large (rather than small) viewing field for gratings less than ~ 3 -4 cycles/deg. For both field sizes, contrast sensitivity increases as spatial frequency increases up to 2-4 cycles/deg; sensitivity then decreases as spatial frequency increases.

Applications

Situations in which fine visual detail must be detected in low-contrast displays, especially when the size of the display can be varied.

Methods**Test Conditions**

- Sine-wave grating, from 0.2-45 cycles/deg
- White CRT screen with average luminance of 500 cd/m² and white cardboard surround with matching illumination
- Central opening in surround either 2 × 2 cm or 10 × 10 cm to allow viewing of CRT screen; viewing distance 57 or 285 cm; 2-cm opening subtended 2 × 2 deg at 57 cm viewing distance; 10-cm opening subtended 10 × 10 deg at 57 cm, and 2 × 2 deg at 285 cm

- Pupil dilated and accommodation paralyzed with homatropine; monocular viewing through 2.5-mm diameter artificial pupil; refraction corrected to within 0.25 diopter for viewing distance
- Contrast varied by adjusting modulation voltage, which switched off and on at 0.5 Hz

Experimental Procedure

- Method of adjustment
- Independent variables: viewing field size, spatial frequency of grating
- Dependent variable: contrast sensitivity, defined as the reciprocal of the contrast between lightest

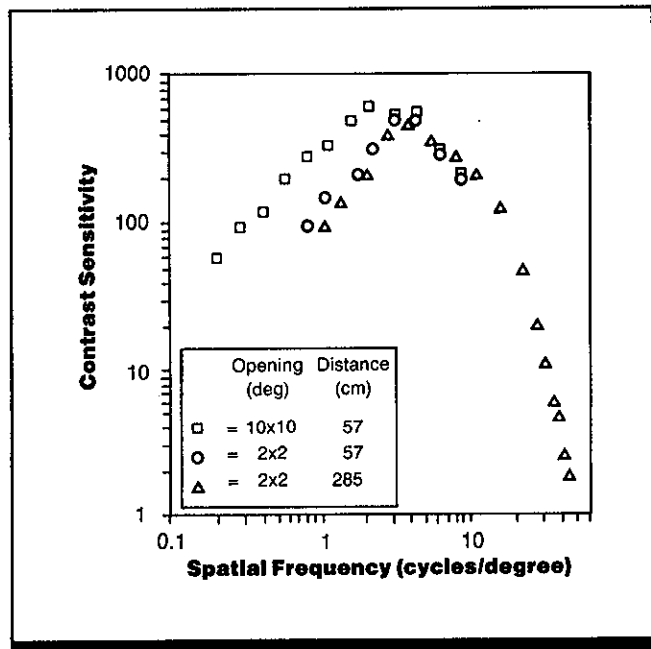

Figure 1. Contrast sensitivity for sine-wave gratings as a function of spatial frequency and field size (indicated as opening size). (From Ref. 2)

- and darkest areas of the grating required to make it just detectable
- Observer's task: adjust contrast of the grating until it is just detectable
- 1 observer with extensive practice

Experimental Results

- Contrast sensitivity is slightly greater with a 10 × 10 deg field than with a 2 × 2 deg field. Maximum sensitivity (lowest threshold) with the 10-deg field occurs with a grating of 2 cycles/deg; maximum sensitivity with the 2-deg field occurs with a grating of 4 cycles/deg.
- Both field sizes produce inverted U-shaped sensitivity functions. Contrast sensitivity is greatest at 2-4 cycles/deg and decreases at higher and lower spatial frequencies.

Constraints

- In this study, changing the field size also changed the number of cycles (number of bars) visible to the observer. This confounds the results, since contrast sensitivity changes with the number of luminance cycles visible (CRef. 1.631; Refs. 3, 4).

Variability

Standard errors of the means were <10%.

Repeatability/Comparison with Other Studies

The contrast sensitivity values reported here are very similar to values obtained in other work using similar pupil sizes, field sizes, and gratings of similar spatial frequency (Ref. 1).

- Results reported are for near-threshold values of contrast; results may be different for high-contrast targets.
- Many factors, such as luminance level, orientation, and visual field location, affect contrast sensitivity for spatial patterns and must be considered in applying these results under different viewing conditions (CRef. 1.628).

Key References

1. Campbell, F. W., & Green, D. G. (1965). Optical and retinal factors affecting visual resolution. *Journal of Physiology*, 181, 576-593.

*2. Campbell, F. W., & Robson, J. G. (1968). Application of Fourier analysis to the visibility of gratings. *Journal of Physiology*, 197, 551-566.

3. Hoekstra, J., van der Goot, D. P. J., van der Brink, G., & Bilsen, F. A. (1974). The influence of the number of cycles upon the visual contrast threshold for spatial sinewave patterns. *Vision Research*, 14, 365-368.

4. Savoy, R. L., & McCann, J. J. (1975). Visibility of low spatial frequency sine-wave targets: Dependence on number of cycles. *Journal of the Optical Society*, 65, 343-350.

Cross References

1.625 Target detection: effect of target spatial dimensions;

1.628 Factors affecting contrast sensitivity for spatial patterns;

1.631 Contrast sensitivity: effect of number of luminance modulation cycles and luminance level

1.630 Contrast Sensitivity: Effect of Spatial Frequency Composition

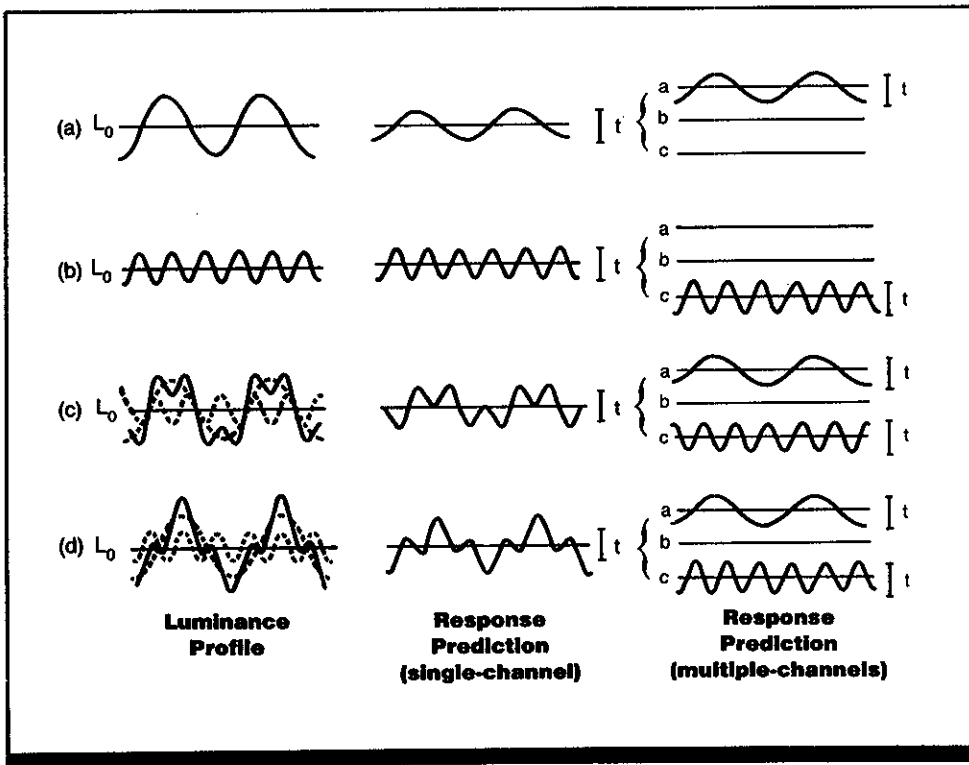

Figure 1. Illustration of target patterns (complex sine-wave gratings). Left column shows physical luminance profiles of: targets (luminance as a function of distance); a and b are component waveforms of the complex gratings used in the study (one at three times the frequency of the other), while c and d show components combined in "peaks-subtract" and "peaks-add" phase relations, respectively. Middle column shows predicted response magnitude as a function of distance under "single-channel" model of contrast detection. Right column shows predicted response under "multiple-channels" model of contrast detection. t indicates threshold amplitude; L_0 is average luminance level. (From Ref. 3)

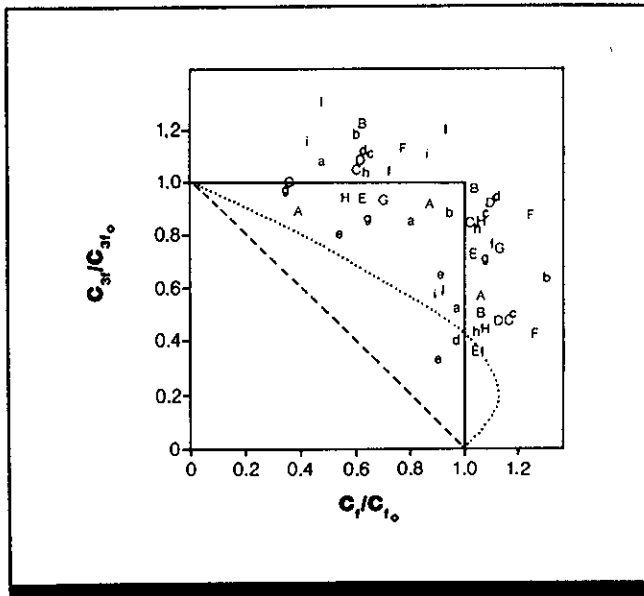

Figure 2. Contrast thresholds for complex gratings shown in Fig. 1. Abscissa shows relative contrast of the fundamental spatial frequency component, f (contrast of component f when the complex gratings $f + 3f$ is at threshold divided by the threshold contrast of f when presented alone); ordinate shows relative contrast of component $3f$ (at 3 times the spatial frequency of f), determined similarly. Contrast increases with distance from the origin. A value of 1.0 indicates that the contrast of the spatial-frequency component in the complex grating equals the threshold contrast of the component when presented alone. Letters represent different spatial frequencies of the fundamental component (see key in text); capital letters indicate peaks-add combination, lower-case letters peaks-subtract combinations. Dashed and dotted lines represent predicted thresholds for peaks-add and peaks-subtract combinations, respectively, when the contrast of the f and $3f$ components summate (i.e., grating threshold is determined by overall pattern contrast). Solid lines represent predicted thresholds when the components are detected independently (i.e., the grating is detected only when one of the two components reaches its individual contrast threshold) (no adjustment is made for probability summation). (From Ref. 3)

Key Terms

Contrast sensitivity; Fourier analysis; pattern detection; size

General Description

The visibility of a cyclical pattern containing more than one spatial-frequency (sine-wave) component is determined by the contrast of its components rather than by the contrast of

the pattern as a whole, provided that the spatial frequencies of the components are at least 1-2 octaves apart (i.e., one component is 2-4 times the frequency of the other). Thus, for many repetitive patterns (e.g., square-wave, rectangu-

lar-wave, or sawtooth gratings), when the fundamental component is near the peak frequency of the contrast sensitivity function (i.e., the frequency of greatest sensitivity)

of the observer, the contrast threshold for the pattern as a whole is determined by the contrast of only the fundamental component.

Applications

Prediction of the visibility of low-contrast patterns.

Methods

Test Conditions

- One-dimensional sine-wave grating pattern presented on CRT; 10.278 cd/m² mean luminance; cross-hairs provided for fixation; 103-cm viewing distance; display masked to 4.8 × 4.4 deg of visual angle except when lower frequency was 0.9 or 1.8 cycles/deg (then ~6 deg diameter screen)
- Each stimulus composed of a fundamental sine wave (f) and a component three times higher in frequency ($3f$) or just one of the two simple sine waves; relative phase of components of complex stimulus set so that luminance peaks subtract (Fig. 1c) or peaks add (Fig. 1d)

- Spatial frequency of the fundamental (f) ranged from 0.9-6.3 cycles/deg as follows (letters refer to data points of Fig. 2; capital letters are peaks-add combinations and lower case peaks-subtract combinations):

Symbols	cycles/deg
A,a	0.9
B,b	1.8
C,c	2.7
D,d	2.7
E,e	3.6
F,f	3.6
G,g	4.5
H,h	5.4
I,i	6.3

- 1.5-mm artificial pupil used with monocular viewing; head stability ensured with bite board

- For each threshold determination for complex patterns, the ratio of the contrast of the lower-frequency component to the contrast for the higher-frequency component always equaled 1/2, 1, or 2 times the ratio of the threshold contrasts for the components

Experimental Procedure

- Method of adjustment for data points denoted by D, d, F and I, and f through i ; staircase procedure using a two-interval forced choice paradigm (with feedback) for all others; blocked design
- Independent variable: relative contrast of the two spatial-frequency components in the complex pattern (where contrast is defined as Michelson contrast); relative

- phase of f and $3f$ components; spatial frequency of components
- Dependent variable: threshold contrast, defined as mean contrast of 10-12 threshold adjustments (adjustment procedure) or contrast at which pattern could be detected on ~70 percent of trials (staircase procedure)
- Observer's task: for adjustment procedure, adjust contrast of complex pattern until barely detectable; for staircase procedure, state which of two 750-msec intervals contained the stimulus pattern
- 1 observer for all data except for E and e, which are from a second observer; both observers had some practice

Experimental Results

- For complex sine-wave gratings (bar patterns) with widely spaced spatial-frequency components, the grating is detected only when the contrast of at least one of the components is at its individual threshold (i.e., contrast at which it is detected when presented alone).
- Subthreshold contrasts of these widely spaced spatial frequencies do not "summate" to lower the threshold for the pattern as a whole.
- Contrast threshold for complex gratings do not depend on the relative phase of the components; thresholds are the same for peaks-add combinations as for peaks-subtract combinations.
- A single-channel model of detection, which holds that threshold is determined solely by the contrast of the pattern as a whole, predicts phase-dependent summation: thresh-

olds for peaks-add combinations should fall on the dashed diagonal line of Fig. 2; thresholds for peaks-subtract combinations should fall on the dotted curve.

- A "multiple-channel" model of detection, which holds that the individual f and $3f$ components are independently detected by separate channels, predicts that thresholds for all gratings will fall on top and right edges of the square; this model provides a better fit to the data; the fit could be improved by taking account of probability summation across components. Many variants of the "multiple-channels" model are described in Ref. 5.

Variability

Standard errors of the mean averaged 0.04 log units.

Repeatability/Comparison with Other Studies

Reference 1 reports similar results.

Constraints

- Phase dependence is generally observed with spatial frequencies lower than the peak of the contrast sensitivity function (Ref. 4).
- Spatial-frequency components are detected independently (i.e., threshold is determined by the contrast of the spatial-frequency components rather than by overall pattern contrast) only when the spatial frequencies of the individual

components are separated by at least a factor of 2-4 (1-2 octaves).

- These results are for near-threshold values of contrast; results may be different for high-contrast targets.
- Many factors (such as luminance level, orientation, and visual field location) affect contrast sensitivity for spatial patterns and must be considered in applying these results under different viewing conditions (CRef. 1.628).

Key References

1. Campbell, F. W., & Robson, J. G. (1964). Application of Fourier analysis to the modulation response of the eye. *Journal of the Optical Society of America*, 54, 581 (Abstract).

2. Campbell, F. W., & Robson, J. G. (1968). Application of Fourier analysis to the visibility of gratings. *Journal of Physiology*, 197, 551-566.

*3. Graham, N., & Nachmias, J. (1971). Detection of grating patterns containing two spatial frequencies: A comparison of single channel and multiple-channel models. *Vision Research*, 11, 251-259.

4. Jaschinski-Kruza, & Cavonius, C. R. (1984). A multiple-channel model for grating detection. *Vision Research*, 24, 933-941.

5. Julesz, B., & Schumer, R. A. (1981). Early visual perception. *Annual Review of Psychology*, 32, 575-627.

Cross References

1.628 Factors affecting contrast sensitivity for spatial patterns;

1.635 Contrast sensitivity: effect of target visual field location for bar patterns of varying size;

Handbook of perception and human performance, Ch. 7, Sect. 2.2

1.631 Contrast Sensitivity: Effect of Number of Luminance Modulation Cycles and Luminance Level

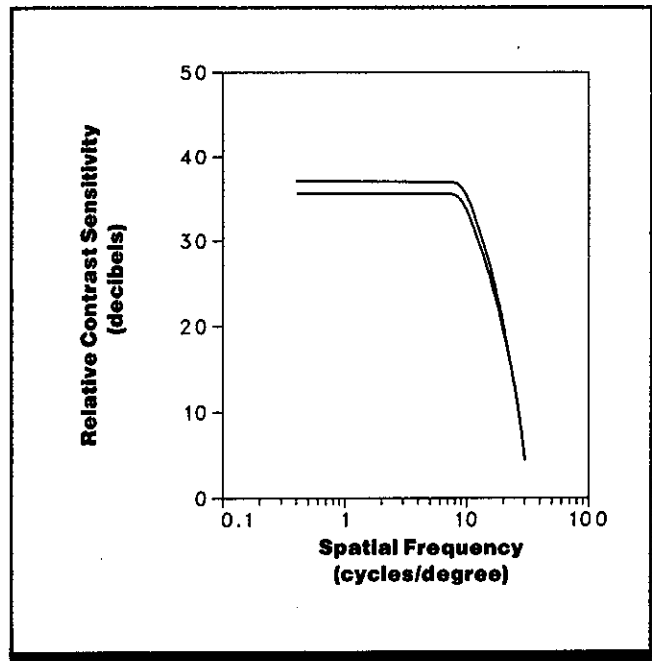
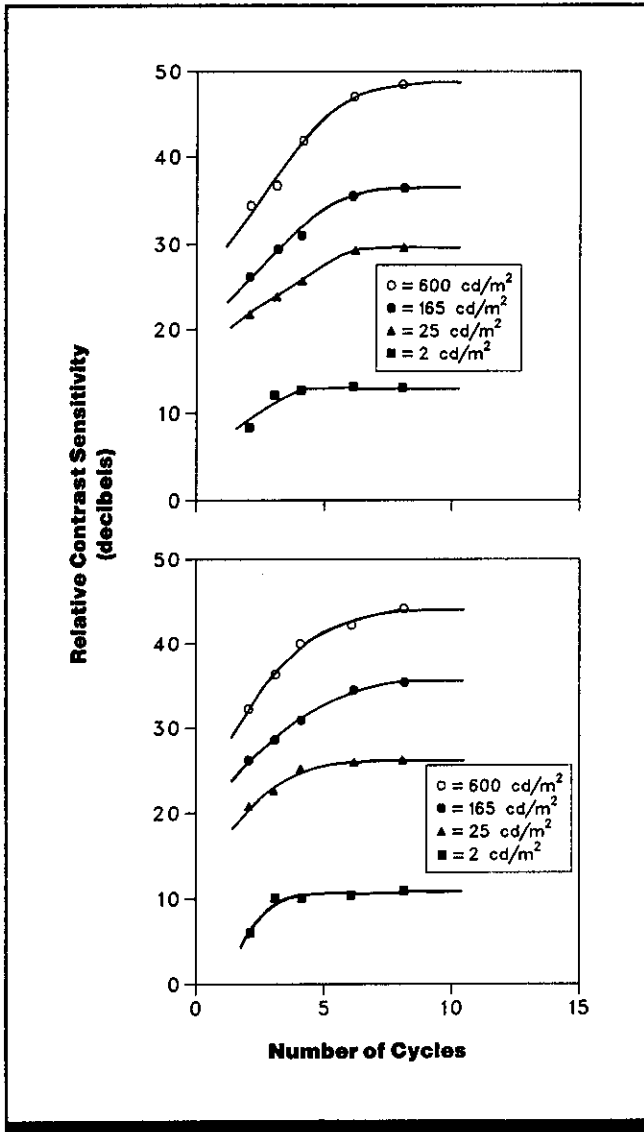

Figure 1. Relative contrast sensitivity for a 2-cycle/deg grating as a function of number of luminance cycles visible at four mean luminance levels; each panel contains the data for 1 observer. Relative contrast sensitivity (the y-axis) is expressed in terms of attenuation in decibels of sine-wave amplitude. One cycle is equal to the period of the grating (or the width of one light plus one dark bar). (From Ref. 2)

Figure 2. Theoretical contrast sensitivity functions after correcting for dependence of contrast sensitivity upon number of cycles visible; each curve is for 1 observer. The y-axis units are the same as in Fig. 1. (From Ref. 2)

Key Terms

Contrast sensitivity; luminance; modulation transfer function; pattern detection; size

General Description

Contrast sensitivity for sine-wave gratings (bar patterns) of low spatial frequency is reduced when fewer than some critical number of cycles (periods) of the pattern are visible. The critical number increases with mean luminance of the

pattern. Contrast sensitivity functions that are corrected for the effects of insufficient cycles indicate that the normal human visual system behaves as a low-pass rather than a band-pass filter; corrected functions show no reduction in sensitivity at spatial frequencies below peak sensitivity.

Applications

Displays and viewing environments where the visibility of coarse low-contrast targets must be maximized.

Methods

Test Conditions

- Test targets: vertical sine-wave gratings presented on a gamma-corrected TV monitor; spatial frequency 2 cycles/deg of visual angle

- Number of cycles visible controlled with masks over CRT screen; visible area never <1 deg
- Mean luminance of grating 2-600 cd/m²
- Observers maintained loose fixation on center of screen

Experimental Procedure

- Trials blocked by number of cycles visible
- Independent variables: number of cycles presented (mask aperture size), mean luminance of grating

- Dependent variable: depth of contrast modulation at threshold (measured as attenuation level in decibels)
- Observer's task: not reported, but probably to adjust contrast of patterns to apparent threshold
- 2 observers

Experimental Results

- At each mean luminance, contrast sensitivity for a grating pattern increases with the number of luminance cycles visible up to some critical number; beyond this critical number of cycles, sensitivity no longer increases with number of cycles presented.
- The critical number of cycles increases with increasing mean luminance: at higher mean luminance, more cycles must be present for maximal sensitivity.
- Results are similar for gratings ranging from 2-7 cycles/deg tested at the two highest luminance levels, indicating that cycle dependence is independent of spatial frequency (data not shown).

- Figure 2 shows theoretical contrast sensitivity curves for the 2 observers after correcting for dependence on the number of cycles visible.

Variability

No information on variability was given.

Repeatability/Comparison with Other Studies

Qualitatively similar results have been obtained in comparing half-cycle and single-cycle with multiple-cycle contrast sensitivity (Ref. 1).

Constraints

- Reference 4 showed that the dependence of contrast sensitivity on number of cycles is often confounded by edge effects at the edges of display masks; after correcting for this, cycle-dependent effects are smaller than those reported here and in fact may be negligible.

- These results are for near-threshold values of contrast; results may be different for high-contrast targets.
- Many factors (such as luminance level, orientation, and visual field location) affect contrast sensitivity for spatial patterns and must be considered in applying these results under different viewing conditions (CRef. 1.628).

Key References

1. Campbell, F. W., Carpenter, R. H. S., & Levinson, J. Z. (1969). Visibility of aperiodic patterns compared with that of sinusoidal gratings. *Journal of Physiology*, 204, 283-298.

*2. Hoekstra, J., van der Goot, D. P. J., van den Brink, G., & Bilsen, F. A. (1974). The influence of the number of cycles upon the visual contrast threshold. *Vision Research*, 14, 365-368.

3. Savoy, R. L., & McCann, J. J. (1975). Visibility of low-spatial-frequency sine-wave targets: Dependence on number of cycles. *Journal of the Optical Society of America*, 65, 343-350.

4. van der Wildt, G. J., & Waarts, R. G. (1983). Contrast detection and its dependence on the presence of edges and lines in the stimulus field. *Vision Research*, 23, 821-830.

Cross References

1.628 Factors affecting contrast sensitivity for spatial patterns;

1.629 Contrast sensitivity: effect of field size;

Handbook of perception and human performance, Ch. 7, Sect. 2.1

1.632 Contrast Sensitivity: Effect of Luminance Level (Foveal Vision)

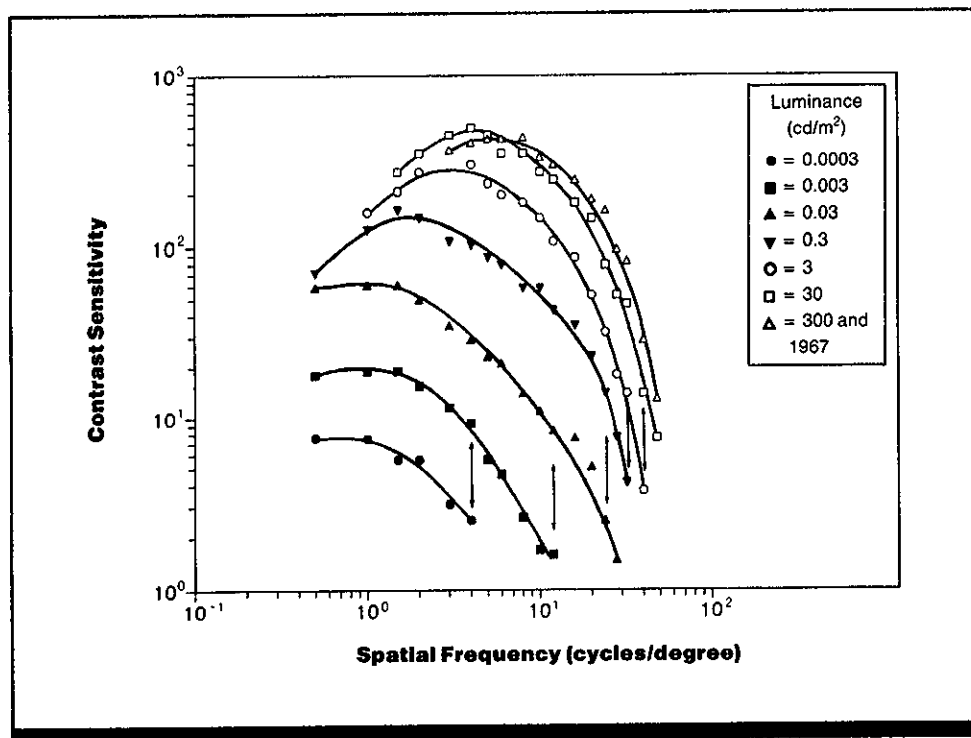

Figure 1. Contrast sensitivity for sine-wave gratings (bar patterns) as a function of spatial frequency and mean target luminance. Arrows show displacement between curves predicted by the deVries-Rose square-root law. (From Ref. 3)

Key Terms

Contrast sensitivity; luminance; modulation transfer function; pattern detection; size

General Description

As luminance level increases to $\sim 300 \text{ cd/m}^2$ (~ 1000 trolands): (1) the ability to detect low-contrast **sine-wave gratings** (bar patterns) improves for all spatial frequencies (number of luminance cycles or pairs of dark and light bars per degree of visual angle); (2) the shape of this **contrast sensitivity function** changes from that of a low-pass filter to

that of a band-pass filter; (3) peak sensitivity occurs at successively higher spatial frequencies. At high luminance levels, contrast sensitivity for circular targets follows Weber's law ($I_t/I_A = \text{constant}$, where I_A is the luminance of the **adapting field** and I_t is the luminance difference between test and adapting fields).

Applications

Contrast sensitivity testing, image processing; situations requiring detection of low-contrast targets.

Methods

Test Conditions

Study 1 (Ref. 3)

- Sine-wave grating viewed **monocularly** in **Maxwellian view**; 2-mm diameter artificial pupil; centrally fixated 4.5-deg horizontal by 8.2-deg vertical gratings
- Adaptation values ranged from 0.00045 to 450 cd/m^2 in 0.1 log unit steps
- Spatial frequencies of 0.5-48 cycles/deg of visual angle
- **Monochromatic** illumination (green, 525 nm); dark surround; mean target luminance kept constant throughout measurements of

each contrast-sensitivity function to keep adaptation level constant

- Contrast (modulation) increased or decreased in 0.1-log unit steps
- Pupil dilated and **accommodation** (eye focus) prevented by 2% homatropine

Study 2 (Ref. 1)

- Target was circular light 40 min arc in diameter; targets viewed monocularly through eyepiece; target presented in center of 12-deg adapting field
- Target duration of 20 msec; targets presented **foveally** at rate of one per 10 sec
- Observer **dark-adapted** for 10 min, then adapted 5 min more

to adapting intensity used during test session

- Preliminary observations determined intensities, ranging from rarely seen to almost always seen

Experimental Procedure

Study 1

- Method of limits; trials blocked by luminance level
- Independent variables: spatial frequency; mean luminance
- Dependent variable: contrast threshold, defined as the average between "just visible" and "just not visible" limits for three consecutive days; plotted in Fig. 1 as contrast sensitivity

- Observer's task: judge whether grating was visible
- 1 observer with extensive experience, using dominant (right) eye which was 3 diopters **myopic**

Study 2

- Independent variable: luminance of adapting field (I_A)
- Dependent variables: threshold luminance, defined as target luminance detected on 60% of presentations (plotted here in terms of contrast rather than luminance)
- 10 observations at each intensity
- Observer's task: report if target present
- 2 observers

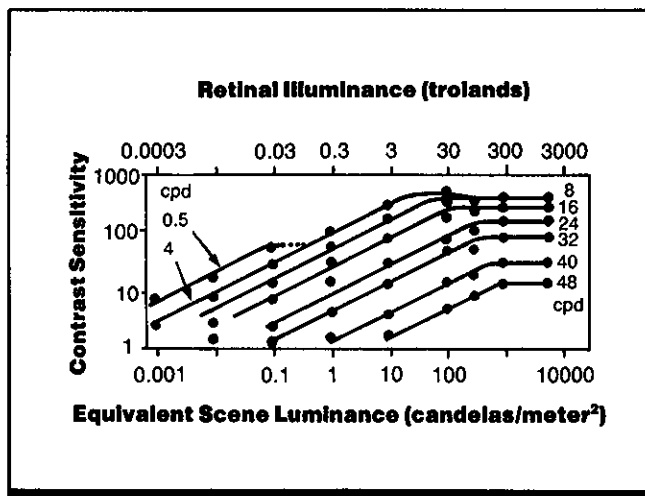

Figure 2. Data of Fig. 1 replotted to illustrate dependence of contrast sensitivity on mean pattern luminance. The dots show average values of visibility limits. Curves are for gratings of different spatial frequencies, measured in cycles per degree of visual angle. (From Ref. 3)

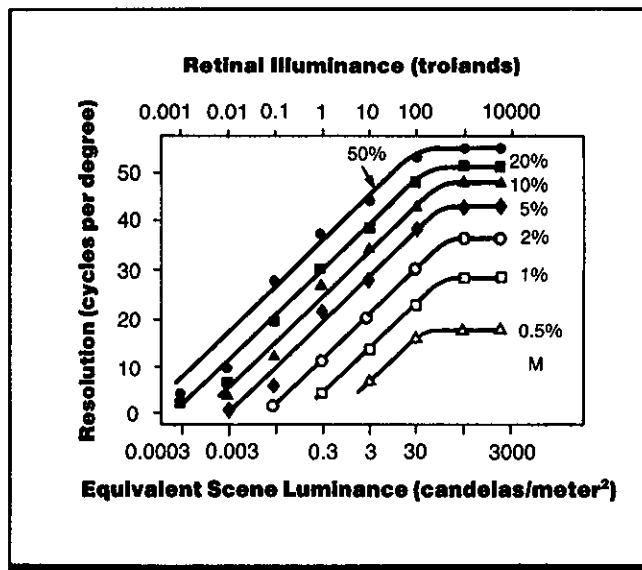

Figure 3. Data of Fig. 1 replotted to show maximum spatial frequency resolved as a function of luminance at several target contrast levels (*M* is percentage contrast modulation). Comparable classic units for visual acuity can be obtained by dividing the *y*-value by 60. (From Ref. 3)

Experimental Results

Study 1 (bar patterns)

- Contrast sensitivity (1/threshold contrast) for sine-wave gratings increases with mean target luminance up to ~ 300 cd/m^2 . The function for 1,967 cd/m^2 is the same as the function for ~ 300 cd/m^2 (Fig. 1).
- Peak sensitivity occurs at higher spatial frequencies as luminance increases (Fig. 1).
- At low luminance levels, sensitivity is roughly constant for lower spatial frequencies, whereas at higher luminances sensitivity decreases from the peak for both lower and higher spatial frequencies (Fig. 1).
- Arrows in Fig. 1 indicate the magnitude of improvement for successive luminance increases predicted by increases in the signal-to-noise ratio due to quantal fluctuations (deVries-Rose law); arrows are not shown for higher illuminances for clarity and because the prediction fails to hold above ~ 100 cd/m^2 .
- Figure 2 shows same data replotted to show dependence of contrast sensitivity on luminance at each spatial frequency; each curve has segments with slopes of 0.5 and zero.
- Figure 3 shows same data replotted to show the maximum spatial frequency that can be resolved at each of several contrast levels, as a function of mean luminance.
- Similar experiments using lights of other wavelengths (450 or 650 nm) indicate that contrast sensitivity is not dependent on hue at photopic illumination levels after correction for optical transfer values that differ from that for 525-nm light.

Study 2 (circular target)

- For adapting luminances up to 1 cd/m^2 , contrast sensitivity improves (i.e., the ratio of test-field incremental luminance at threshold to adapting-field luminance decreases) proportionately as adapting luminance increases.

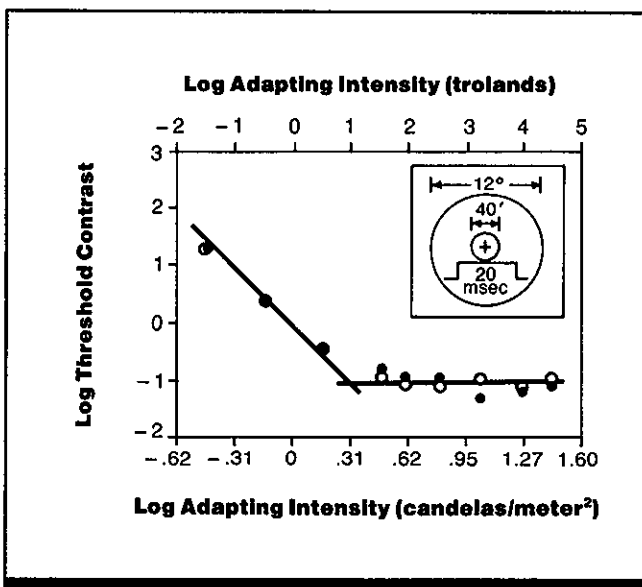

Figure 4. Contrast threshold for circular targets as a function of the adapting (background) field luminance. Inset shows target configuration. (Note that ordinate plots contrast threshold, rather than contrast sensitivity as in Figs. 1 and 2; contrast sensitivity is the reciprocal of contrast threshold.) Filled and open circles represent data for two different observers. (From *Handbook of perception and human performance*, based on data from Ref. 1)

- For intermediate adaptation levels, contrast sensitivity continues to improve as adapting luminance increases, but the slope of the function decreases.
- At high adaptation levels (> 10 cd/m^2), contrast sensitiv-

1.6 Spatial Sensitivity

ity does not change with further increases in adapting luminance. Weber's law holds at these values (i.e., the incremental target luminance I_t is a constant proportion of the adapting luminance I_A).

Variability

Authors of Study 1 estimate the range between just visible and not visible to be within 0.3 log units of contrast. No information on variability was given for Study 2.

Constraints

- Without the use of artificial pupils and Maxwellian view, contrast sensitivity may be somewhat different due to variations in retinal illuminance and focus of the eyes.
- The proportionate increases of threshold with adapting intensity may not hold for high adapting intensities.
- The heights of the contrast sensitivity functions vary for different observers and different psychophysical procedures.

- These results are for near-threshold values of contrast; results may be different for high-contrast targets.
- Many factors (such as luminance level, orientation, and visual field location) affect contrast sensitivity for spatial patterns and must be considered in applying these results under different viewing conditions (CRef. 1.628).

Key References

*1. Mueller, C. G. (1950). Frequency of seeing functions for intensity discrimination at various levels of adapting intensity. *Journal of General Psychology*, 34, 463-474.

2. Olzak, L. A., & Thomas, J. P. (1986). Seeing spatial patterns. In K. R. Boff, L. Kaufman, & J. P. Thomas (Eds.), *Handbook of perception and human performance: Vol. 1. Sensory processes and perception*. New York: Wiley.

*3. Van Nes, F. L., & Bouman, M. A. (1967). Spatial modulation transfer in the human eye. *Journal of the Optical Society of America*, 57, 401-406.

Cross References

1.604 Visual acuity: effect of luminance level;

1.628 Factors affecting contrast sensitivity for spatial patterns;

1.631 Contrast sensitivity: effect of number of luminance modulation cycles and luminance level;

1.633 Contrast sensitivity: effect of luminance level (peripheral vision);

1.643 Contrast sensitivity: effect of target shape and illumination level

Notes

1

2

3

4

1.633 Contrast Sensitivity: Effect of Luminance Level (Peripheral Vision)

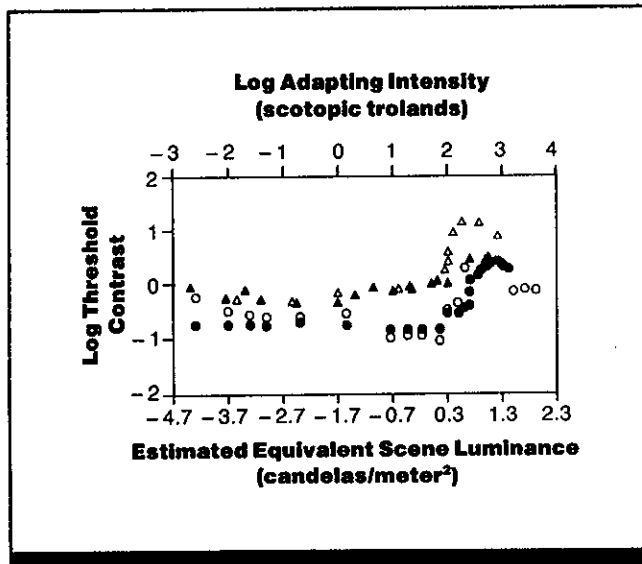

Figure 1. Contrast threshold as a function of intensity of the adapting (background) field. Symbols represent data for four different observers. Conversions from trolands to cd/m^2 are based on a dilated pupil diameter of 8 mm. (From Ref. 1)

Key Terms

Contrast; contrast sensitivity; luminance; peripheral vision; rod vision; scotopic vision

General Description

At adaptation levels (background intensities) of less than $\sim 2 \text{ cd/m}^2$, contrast threshold for a circular target centered 9 deg from fixation is roughly constant, regardless of adapting luminance. As adaptation level increases above $\sim 2 \text{ cd/m}^2$, however, contrast threshold increases rapidly (sensitivity falls).

Applications

Displays and viewing environments where the visibility of low-contrast targets must be maximized.

Methods

Test Conditions

- Observer dark-adapted for 30 min
- Green test target 9 deg of visual angle in diameter presented in center of 20-deg diameter red adapting

- field, centered 9 deg temporal from fixation point
- Target presented for 200 msec every one sec until limit of visibility reached (determined by mean of two independent settings)
- After each measurement, field intensity increased, and observer

- viewed it for 2-3 min prior to next target presentation
- Monocular presentation by Maxwellian view; effective pupil size $1.8 \text{ mm} \times 1.8 \text{ mm}$

Experimental Procedure

- Method of adjustment

- Independent variable: adapting field luminance
- Dependent variable: luminance of target at threshold
- Observer's task: adjust luminance of target until it was just visible
- 4 observers, 20-30 yr

Experimental Results

- Experimental conditions (target location in the visual field, target wavelength, exposure duration, and target size) were chosen to favor detection by the rod system.
- At the lowest background intensities, contrast threshold remains constant at 20% over a ~4 log-unit range of luminance levels.
- Above 2 cd/m², contrast threshold rises rapidly (contrast sensitivity declines) with further increases in adapting luminance. This reflects the phenomenon of "rod saturation." At ~120-300 cd/m², the rod mechanism is no longer capable of responding to increased target luminance.

Constraints

- Viewing conditions were chosen to minimize contribution of cones and maximize that of rods. Therefore, data may be valid only for conditions of rod-only stimulation at scotopic levels of illumination.

Key References

*1. Aguilar, M., & Stiles, W. S. (1954). Saturation of the rod mechanism of the retina at high levels of stimulation. *Optica Acta*, 1, 59-65.

2. Stiles, W. S. (1939). The directional sensitivity of the retina and the spectral sensitivities of the rods and cones. *Proceedings of the Royal Society of London (Series B)*, 127B, 64-105.

Cross References

1.401 Brightness difference threshold: effect of background luminance;

1.403 Brightness difference threshold: effect of background luminance and target size;

1.604 Visual acuity: effect of luminance level;

1.624 Factors affecting detection of spatial targets;

1.628 Factors affecting contrast sensitivity for spatial patterns;

- The subsequent decrease in contrast threshold at the highest adaptation levels indicates intrusion from the cone system.

Variability

No specific information on variability was given. Some variability in the data for individual subjects is apparent from Fig. 1.

Repeatability/Comparison with Other Studies

Results are consistent with those found for a single observer in Ref. 2.

- These results are for near-threshold values of contrast; results may be different for high-contrast targets.
- Many factors (such as luminance level, orientation, and visual field location) affect contrast sensitivity for spatial patterns and must be considered in applying these results under different viewing conditions (CRef. 1.628).

1.632 Contrast sensitivity: effect of luminance level (foveal vision);

1.643 Contrast sensitivity: effect of target shape and illumination level;

Handbook of perception and human performance, Ch. 5, Sect. 3.2

1.634 Contrast Sensitivity: Effect of Target Orientation

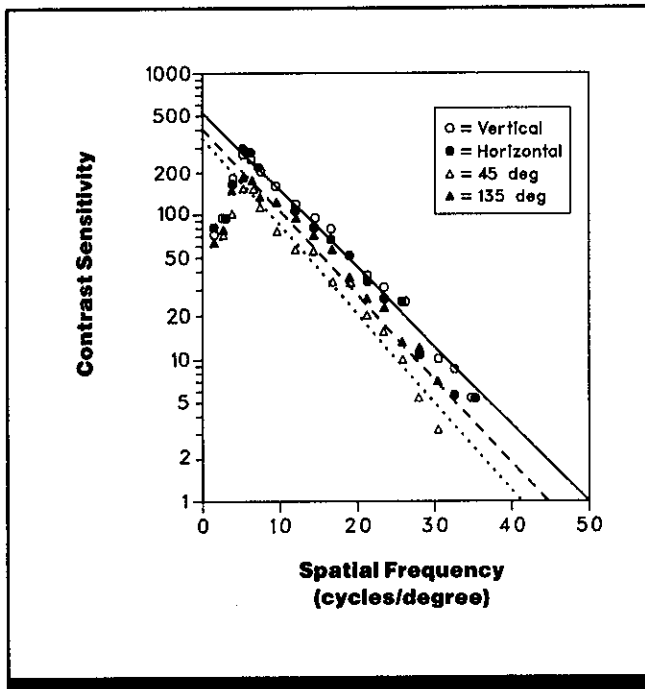

Figure 1. Contrast sensitivity for sine-wave grating targets as a function of grating orientation. (From Ref. 6)

Key Terms

Contrast sensitivity; oblique effect; pattern detection; size; spatial orientation

General Description

Sine-wave gratings (bar patterns) are less visible when oriented obliquely than when oriented vertically or horizontally. This decrement becomes more pronounced as spatial frequency increases (bar size decreases).

Applications

Displays and viewing environments where the visibility of low-contrast targets must be maximized.

Methods

Test Conditions

- Spatial sine-wave luminance gratings generated on a cathode-ray tube masked to 2 deg of visual angle diameter, mounted on a turntable to vary orientation

- Gratings varied independently in contrast and spatial frequency, while mean luminance (170 cd/m^2) constant throughout
- Gratings flashed on and off at 2 Hz and were viewed through 3-mm artificial pupils
- Viewing distance: 162 cm

Experimental Procedure

- Ascending method of limits (0.05 log unit steps)
- Independent variables: spatial frequency, orientation
- Dependent variable: contrast threshold (mean contrast at which target was just visible), where con-

trast is defined as Michelson contrast; figure plots contrast sensitivity (reciprocal of contrast threshold)

- Observer's task: report whether grating is visible
- 2 normal and presumably experienced observers; Fig. 1 plots data for one observer

Experimental Results

- At spatial frequencies higher than the peak of the **contrast sensitivity function** (~5-6 cycles/deg), sensitivity is greater for vertical and horizontal than for oblique orientations.
- Contrast sensitivity is greater at 45 than at 135 deg orientation.
- Straight lines in Fig. 1 are fitted by eye (note semilog coordinate axes) to data points between peak and upper limit of resolution for vertical and horizontal orientations combined and for each oblique orientation.
- Grating acuity, as indicated by spatial frequency where contrast sensitivity meets the x -axis, is also worse for oblique than for non-oblique orientations.
- Ratio of the slope for 135 deg to the slope for vertical and horizontal orientations is 1.12, indicating proportionally worse oblique sensitivity as spatial frequency increases.

Constraints

- Individuals with **astigmatism** uncorrected at an early age show a permanent reduction of contrast sensitivity to orientations for which they show focus errors.
- Depressed sensitivity to oblique orientations may have its origins in the relative infrequency of oblique contours in urban culture (Ref. 1).
- These results are for near-threshold values of contrast; results may be different for high-contrast targets.

Key References

1. Annis, R. C., & Frost, B. (1973). Human visual ecology and orientation anisotropies in acuity. *Science*, 182, 729-731.
2. Campbell, F. W., Kulikowski, J. J., & Levinson, J. (1966). The effect of orientation on the visual resolution of gratings. *Journal of Physiology*, 187, 427-436.

3. Fiorentini, A., Ghez, C., & Maffei, L. (1972). Physiological correlates of adaptation to a rotated visual field. *Brain Research*, 42, 544-545.
4. Fiorentini, A., Ghez, C., & Maffei, L. (1972). Physiological correlates of adaptation to a rotated visual field. *Journal of Physiology*, 227, 313-322.

The change in grating visibility with spatial frequency for oblique orientations can be described by the function

$$S(f) = A^{-akf}$$

where $S(f)$ is contrast sensitivity, A is a constant which depends on intensity and focus state, a is the slope of the function for the most visible orientation when plotted on semilog coordinates, k is a coefficient that depends on orientation, and f is spatial frequency (Ref. 2).

Variability

No information on variability was given.

Repeatability/Comparison with Other Studies

Reference 2 found average ratio of slope for oblique gratings to slope for non-oblique gratings to be 1.22, for 3 observers. Similar experiments using interference fringes formed directly on the retina (Refs. 2, 5) rule out optical explanations of this oblique effect.

- Many factors (such as luminance level, orientation, and visual field location) affect contrast sensitivity for spatial patterns and must be considered in applying these results under different viewing conditions (CRef. 1.628).
- Criterion effects may account for some of the differences in contrast sensitivity with orientation.
- Practice can reduce the effect of orientation on contrast sensitivity.
- Orientation interacts with the number of visible cycles in influencing contrast sensitivity (Ref. 7, CRef. 1.631).

5. Mitchell, D. E., Freeman, R. D., & Westheimer, G. (1967). Effect of orientation on the modulation sensitivity for interference fringes on the retina. *Journal of the Optical Society of America*, 57, 246-249.
- *6. Mitchell, D. E., & Wilkinson, F. (1974). The effect of early astigmatism on the visual resolution of gratings. *Journal of Physiology*, 243, 739-756.

7. Quinn, P. C., & Lehmkuhle, S. (1983). An oblique effect of spatial summation. *Vision Research*, 23, 655-658.
8. Weitzman, D. O., Smith, J. M., & Karasik, R. (1972). Signal detection analysis of meridional variations to vertical and horizontal gratings. *Vision Research*, 12, 1755-1758.

Cross References

- 1.628 Factors affecting contrast sensitivity for spatial patterns;
- 1.631 Contrast sensitivity: effect of number of luminance modulation

- cycles and luminance level;
- 1.652 Orientation-selective effects on contrast sensitivity;
- Handbook of perception and human performance*, Ch. 7, Sect. 2.1

1.635 Contrast Sensitivity: Effect of Target Visual Field Location for Bar Patterns of Varying Size

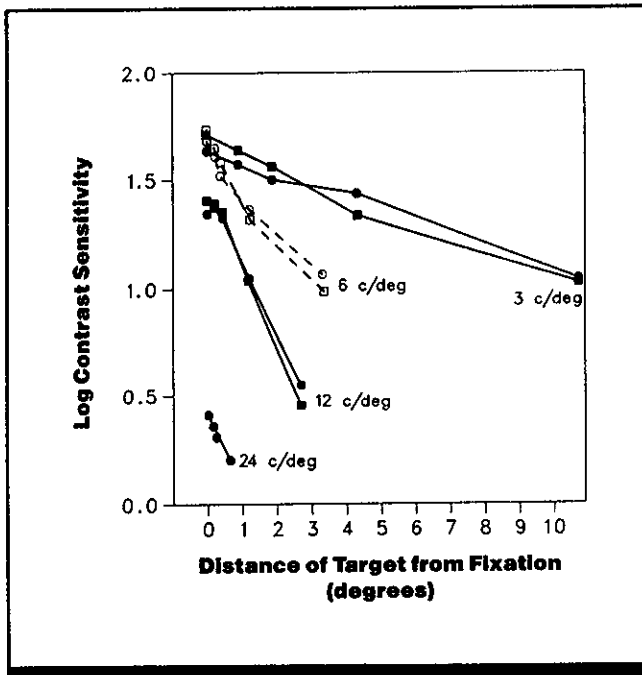

Figure 1. Contrast sensitivity as a function of target distance from fixation (retinal eccentricity). Squares and circles represent the results for two different observers; each point is the average for targets above and below the fixation point. (From Ref. 3)

Key Terms

Contrast sensitivity; pattern detection; peripheral vision; retinal location; size; visual field location

General Description

Contrast sensitivity for sine-wave gratings (bar patterns) declines approximately linearly with increasing distance of the target from foveal fixation (retinal eccentricity). This re-

lationship holds for all spatial frequencies (bar widths), but the rate of decrease accelerates at higher spatial frequencies. Target detectability is best for targets at the center of the visual field (those that fall on the retinal fovea).

Applications

Displays and viewing environments where the visibility of low-contrast targets must be maximized, especially situations where the observer must detect targets that are not in the center of the visual field, such as vigilance tasks with multiple target locations and tasks where there is spatial uncertainty regarding target location.

Methods

Test Conditions

- Targets were sine-wave gratings, with height and width equal to four grating cycles (where one cycle equals twice the width of an individual bar); horizontally oriented; presentation via CRT

- Center of pattern located above or below fixation point at distance of 0, 1, 2, 4, 8, 16, or 32 pattern cycles from fixation
- Mean luminance = 500 cd/m²; pattern contrast varied
- Spatial frequency of 3-24 cycles/deg, varied by changing viewing distance

Experimental Procedure

- Staircase procedure, two-interval forced-choice paradigm (two temporal intervals with target present during only one of the intervals)
- Independent variable: distance of center of target from fixation (retinal eccentricity)
- Dependent variable: contrast threshold, defined as grating con-

- trast at which observer correctly detected target on 90% of trials; figure plots contrast sensitivity (reciprocal of contrast threshold)
- Observer's task: report which of two intervals contained grating target
- Four determinations per data point
- 2 practiced observers

Experimental Results

- For all spatial frequencies tested (3-24 cycles/deg), contrast sensitivity for bar patterns is greatest at or very close to the fixation point, and decreases with increasing distance from fixation.
- Contrast sensitivity decreases faster with distance from fixation for finer bar patterns (higher spatial frequencies) than for coarser patterns.

Variability

Standard error of the mean was ~ 0.025 log units. Between-observer variability was not reported; some small differences between subjects are apparent in Fig 1.

Repeatability/Comparison with Other Studies

A similar decrease in target detection (i.e., an increasing threshold contrast) with distance from fixation has been found for circular targets (CRef. 1.636). References 1 and 2 found results for moving sine-wave gratings that are similar to the results reported here.

Constraints

- Contrast sensitivity is known to vary with target size (CRefs. 1.625, 1.631, 1.636); in this study the number of bars visible was held constant for all targets, hence overall target size varied with spatial frequency.

- A number of other factors, such as measurement technique, practice, luminance level, and number of cycles visible, affect contrast sensitivity and must be considered in applying the results under different conditions (CRef. 1.628).

Key References

1. Koenderink, J. J., Bouman, M. A., Bueno de Mesquita, A. E., & Slappendel, S. (1978). Perimetry of contrast detection thresholds of moving spatial sine wave

patterns. I. The near peripheral visual field (eccentricity 0-8 deg). *Journal of the Optical Society of America*, 68, 845-849.

2. Koenderink, J. J., Bouman, M. A., Bueno de Mesquita, A. E.,

& Slappendel, S. (1978). Perimetry of contrast detection thresholds of moving spatial sine wave patterns. II. The far peripheral visual field (eccentricity 0-50 deg). *Journal of the Optical Society of America*, 68, 850-854.

*3. Robson, J. G., & Graham, N. (1981). Probability summation of regional variation in contrast sensitivity across the visual field. *Vision Research*, 21, 409-418.

Cross References

1.625 Target detection: effect of target spatial dimensions;
1.628 Factors affecting contrast sensitivity for spatial patterns;

1.631 Contrast sensitivity: effect of number of luminance modulation cycles and luminance level;

1.634 Contrast sensitivity: effect of target orientation;

1.636 Contrast sensitivity: effect of visual field location for circular targets of varying size;

Handbook of perception and human performance, Ch. 7, Sect 2.1

1.636 Contrast Sensitivity: Effect of Visual Field Location for Circular Targets of Varying Size

Key Terms

Contrast sensitivity; pattern detection; peripheral vision; retinal location; size; visual field location

General Description

The ability to detect faint circular targets on a bright background decreases as target distance from the fixation point (retinal eccentricity) increases; the effect becomes larger as target size decreases.

Applications

Situations where the observer must detect low-contrast targets that are not in the center of the visual field; vigilance tasks with multiple locations; uncertainty situations.

Methods

Test Conditions

- Circular lights, 1-120 min arc of visual angle in diameter; 0.33-sec exposure duration
- Targets 0-12.5 deg from fixation in the horizontal meridian
- Background at 257 cd/m²
- Viewing distance 2.7-3.8 m
- Free binocular viewing

Experimental Procedure

- Method of constant stimuli

- Independent variables: target distance from fixation, target size
- Dependent variable: target contrast threshold, (contrast at which target was detected on 50% of trials), where contrast is defined as the incremental target luminance above background luminance divided by the background luminance (contrast ratio)
- Observer's task: indicate whether target was seen
- 4 highly practiced observers

Experimental Results

- Contrast threshold increases as target distance from fixation increases.
- Contrast threshold increases as target size decreases.
- Target eccentricity and size interact; the effect of target distance from fixation becomes greater as target size decreases.

Constraints

- These results are for near-threshold values of contrast; results may be different for high-contrast targets.
- Many factors (such as luminance level, orientation, and visual field location) affect contrast sensitivity for spatial patterns and must be considered in applying these results under different viewing conditions (CRef. 1.628).

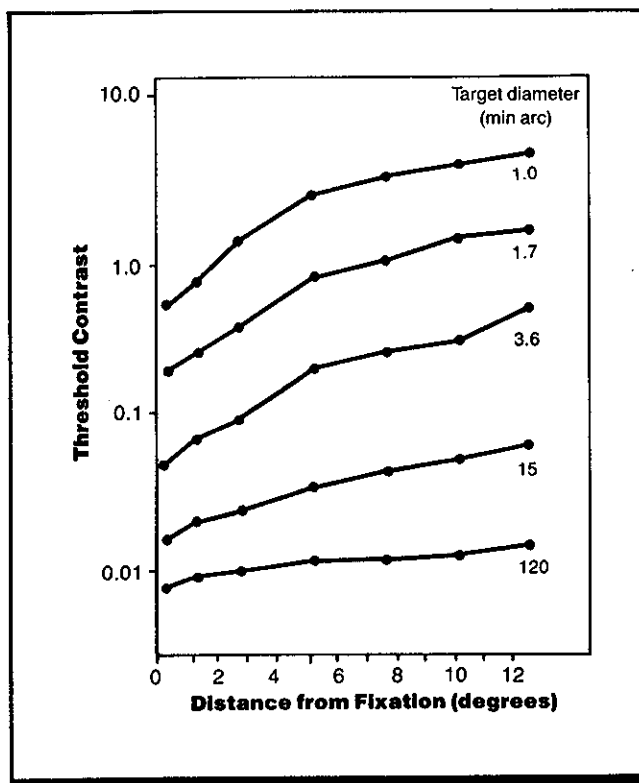

Figure 1. Threshold contrast for circular target lights varying in size from 1 to 120 min arc and presented at various distances from the fixation point (i.e., various retinal eccentricities). (From Ref. 1)

Variability

Mean variability was ~35% among observers. Individual differences decrease as target size increases.

Key References

*1. Blackwell, H. R., & Moldauer, A. B. (1958). *Detection thresholds for point sources in the near periphery* (ERI Project 2455). Ann Arbor: Engineering Research Insti-

tute, the University of Michigan. (DTIC No. AD759739)

2. Farrell, R. J., & Booth, J. M. (1984). *Design handbook for imagery interpretation equipment*. Seattle, WA: Boeing Aerospace Co.

*3. Taylor, J. H. (1963). *Contrast thresholds as a function of retinal position and target size for the light-adapted eye: II. Data Supplement* (SIO Ref. 63-3). San Diego: Scripps Institution of Oceanography. (DTIC No. AD600910)

Cross References

1.305 Factors affecting sensitivity to light;

1.624 Factors affecting detection of spatial targets;

1.628 Factors affecting contrast sensitivity for spatial patterns;

1.631 Contrast sensitivity: effect of number of luminance modulation cycles and luminance level;

1.635 Contrast sensitivity: effect of target visual field location for bar patterns of varying size

1.637 Contrast Sensitivity: Effect of Target Motion

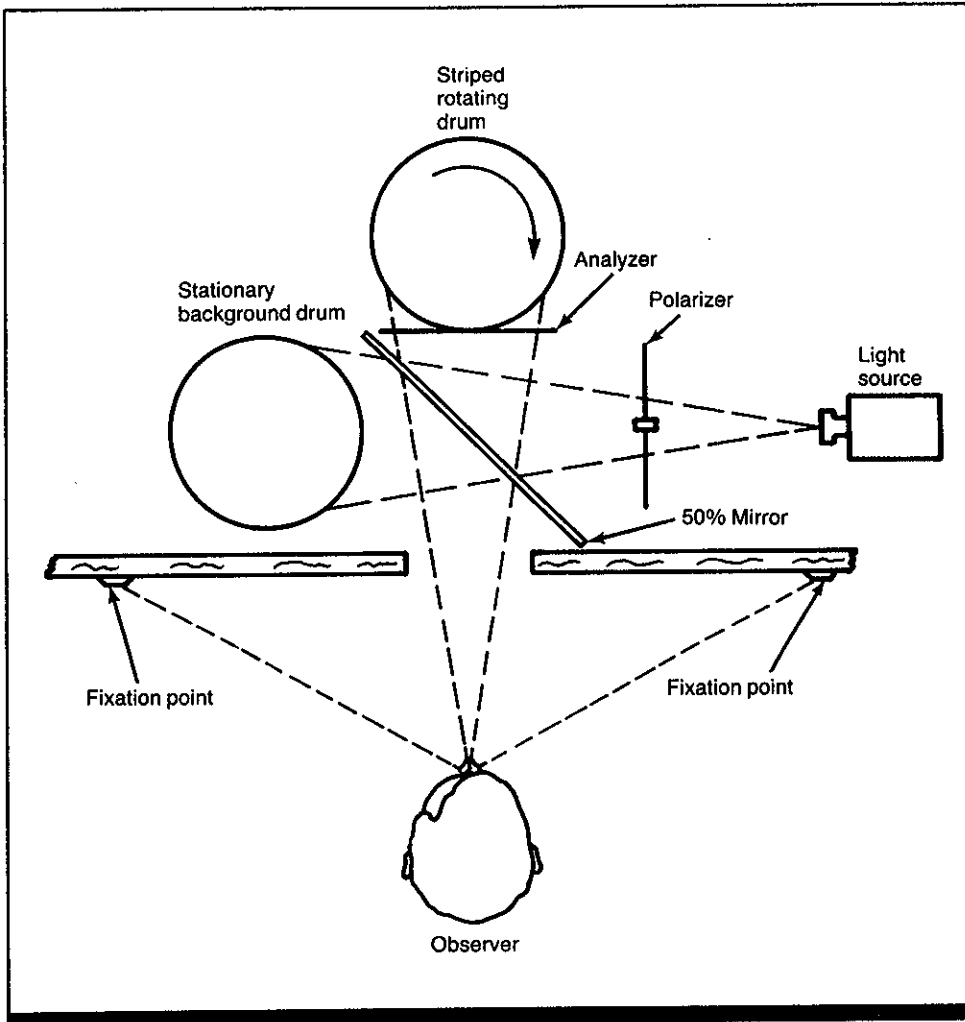

Figure 1. Experimental apparatus for foveal and peripheral viewing of moving or stationary bar patterns; side fixation points used to produce peripheral viewing. (From Ref. 1)

Key Terms

Contrast sensitivity; pattern detection; peripheral vision; retinal location; target motion; visual field location

General Description

A moving target is easier to detect than a stationary target with either foveal or peripheral viewing, but the advantage for the moving target is greater for peripheral viewing.

Contrast threshold for moving targets varies little as target distance from fixation increases; however, the contrast required to detect a stationary target increases the further the target is from fixation.

Applications

Displays and viewing environments where the visibility of low-contrast targets must be maximized.

Methods

Test Conditions

- Monocular viewing of low-contrast, vertically oriented bars, with each bar subtending 5 deg visual angle; viewing distance of 0.46 m (18 in.)
- Target was either stationary or moving to the left at 24 deg/sec through 20-deg visual field; moving image generated by rotating

drum with vertical black and white stripes (see Fig. 1)

- Center of target was at 0 deg (foveal condition) or 55 deg (peripheral condition) to left or right of fixation; additional data collected later at 20 and 40 deg from fixation; because of equipment constraints, target was slightly out of focus for these angles
- Luminance of white bars on rotating drum gradually increased

until target visible; field luminance (background) 9.87 cd/m²; maximum luminance of bars 13.05 cd/m²; luminance controlled by crossed polarizers

Experimental Procedure

- Method of adjustment
- Independent variables: moving or stationary bars, target distance from fixation
- Dependent variables: mean con-

trast threshold, where contrast is defined as brightness difference between target bar and background divided by mean luminance

- Subject's task: adjust target luminance so that bars were halfway between being just barely visible and being not visible
- 10 male and female college students

Experimental Results

- Observers can more easily detect a moving target than a stationary target ($p < 0.001$) with both foveal and peripheral vision. This advantage is greater for peripheral (versus foveal) viewing.
- For stationary targets, greater contrast is required for detection in the periphery of the visual field (55 deg from fixation) than at the center of the visual field ($p < 0.001$).

- For a moving target, there is no difference in target detectability with foveal and peripheral viewing.
- No difference was found between left-eye and right-eye viewing.

Variability

An analysis of variance was conducted to test the significance of the independent variables and interactions; only data for 0 deg and 55 deg from fixation were included in the analysis.

Constraints

- Failure to detect a moving target may be due to pattern fusion, flicker fusion, or inadequate brightness or contrast.
- These results are for near-threshold values of contrast; results may be different for high-contrast targets.

- Many factors (such as luminance level, orientation, and visual field location) affect contrast sensitivity for spatial patterns and must be considered in applying these results under different viewing conditions (CRef. 1.628).

Key References

- *1. Rogers, J. G. (1972). Peripheral contrast thresholds for moving images. *Human Factors*, 14, 199-205.

Cross References

- 1.617 Visual acuity with target motion: effect of target velocity and target versus observer movement;
- 1.618 Visual acuity with target motion: effect of target velocity and orientation;
- 1.628 Factors affecting contrast sensitivity for spatial patterns;
- 1.635 Contrast sensitivity: effect of

target visual field location for bar patterns of varying size;

1.636 Contrast sensitivity: effect of visual field location for circular targets of varying size;

5.205 Perception of motion in the visual periphery;

5.206 Sensitivity to direction of motion in the visual periphery;

11.410 Alerting signals in the peripheral visual field: use of apparent motion

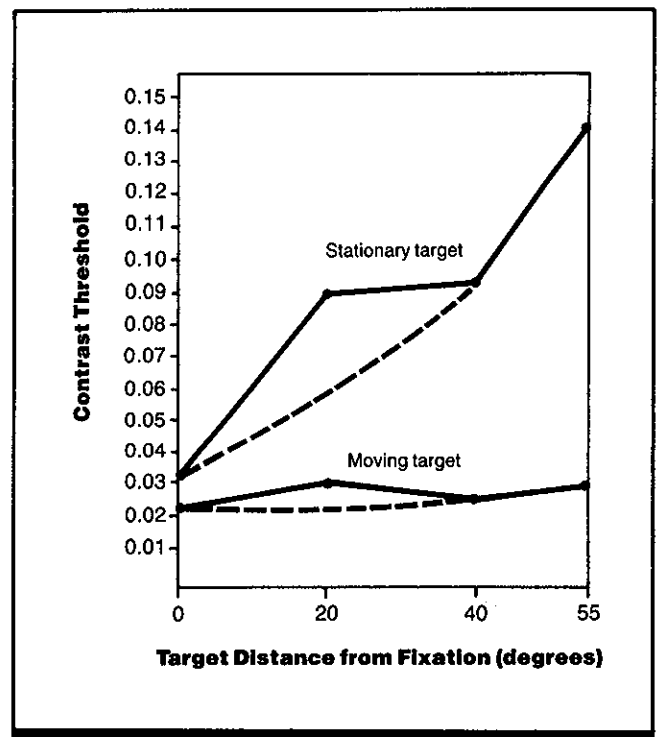

Figure 2. Contrast threshold for moving and stationary bar patterns as a function of the distance of the target from the fixation point. Hump in the curve at 20 deg eccentricity is thought to be an artifact caused by out-of-focus viewing for these targets; dashed line indicates expected locus of curve with this artifact eliminated. (From Ref. 1)

1.638 Contrast Sensitivity: Effect of Pupil Size

Key Terms

Contrast sensitivity; modulation transfer function; pattern detection; pupil size; size

General Description

Contrast sensitivity for a sine-wave grating (bar pattern) is greatest with a pupil size of 2 mm. An eye with a 2-mm pupil has an optical attenuation in agreement with a diffraction-limited system (CRef. 1.213). With increasing pupil size, the performance of the optics deviates progressively from a perfect optical system. For all pupil sizes, at an average target luminance of 100 cd/m², contrast sensitivity for sine-wave gratings reaches a peak at a spatial frequency of ~5-9 cycles per deg, and declines rapidly at higher spatial frequencies.

Applications

Displays and viewing environments where the visibility of low-contrast targets must be maximized.

Methods**Test Conditions**

- Sine-wave gratings, from 2-10 cycles per deg in single deg steps, then from 10-46 cycles per deg in 2-deg steps
- 2 × 1.3 deg field
- CRT display with green phosphor; screen luminance 100 cd/m² (30 fL)
- Equiluminous surround

- Accommodation fixed by lens; pupil dilated by drugs; viewing through an artificial pupil 2.0, 3.8, or 5.8 mm in diameter
- Changes in retinal illumination due to changes in artificial pupil area compensated by neutral density filter

Experimental Procedure

- Method of adjustment, always starting from a suprathreshold value

Experimental Results

- Contrast sensitivity is greatest with a 2-mm pupil and with a grating (bar pattern) of 9 cycles per deg. A 3.8-mm pupil and a 5.8-mm pupil yield best sensitivity with gratings of 5 cycles per deg and 4 cycles per deg, respectively.
- All three pupil diameters produced similar contrast threshold functions: contrast sensitivity is greatest at ~9 cycles per deg or less and falls off rapidly at spatial frequencies >10 cycles per deg.
- Measured optical attenuation for a 2-mm pupil agrees with that predicted for a diffraction-limited system. With increasing pupil size, the performance of the optics deviates progressively from a perfect optical system.

Constraints

- Methodology employed (method of adjustment always starting at suprathreshold value) is open to question because of possible "anticipations" by observers. Because the observer is always adjusting the dial in the same direction, the strategy or "set" adopted by the observer can affect the results. This is especially noteworthy because the sensitivity values reported here are better than in previous studies.

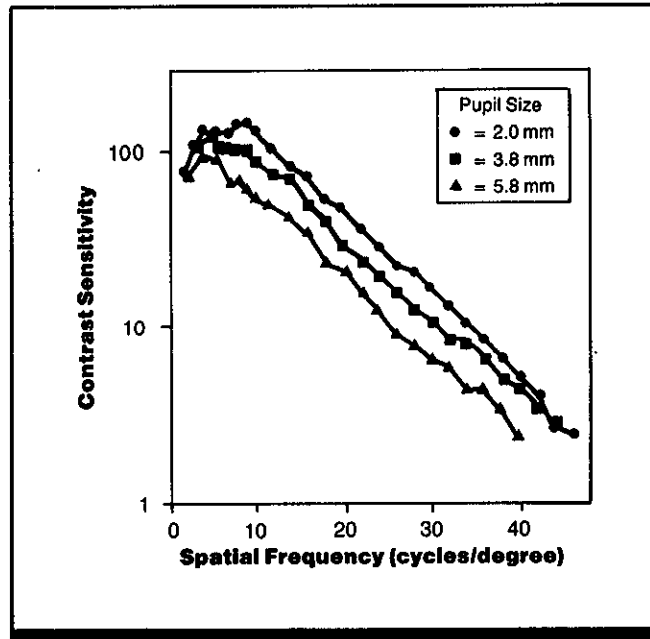

Figure 1. Contrast sensitivity as a function of spatial frequency and pupil diameter. (From Ref. 2)

- Independent variables: pupil size, spatial frequency of test grating
- Dependent variable: contrast threshold (contrast between light and dark areas of grating required to make the grating just detectable);

- figure plots contrast sensitivity (reciprocal of threshold contrast)
- Observer's task: adjust contrast of the grating until the grating is just detectable
- 1 observer, highly practiced

Variability

- No information on variability was given.

Repeatability/Comparison with Other Studies

Due to differences in technique, there are small discrepancies between values reported here for contrast sensitivity and in other studies (Refs. 1, 3). The technique used here indicates quality of the optical image is much better than when estimated by ophthalmoscopic techniques. Measurements obtained in other ways show similar trends in contrast sensitivity as a function of pupil size.

- Results reported here apply only to near-threshold values of contrast; results may be different for high-contrast targets.
- Many factors (such as luminance level, orientation, and visual field location) affect contrast sensitivity for spatial patterns and must be considered in applying these results under different viewing conditions (CRef. 1.628)

Key References

1. Arnulf, A., & Dupuy, O. (1960). La transmission des contrastes par le système optique de

l'oeil et les seuils des contrastes rétinien. *Comptes Rendus. Académie des Sciences (Paris)*, 250, 2757-2759.

*2. Campbell, F. W., & Green, D. G. (1965). Optical and retinal factors affecting visual resolution. *Journal of Physiology*, 181, 576-593.

3. Westheimer, G. (1960). Modulation thresholds for sinusoidal light distributions on the retina. *Journal of Physiology*, 152, 67-74.

Cross References

1.213 Diffraction of light in optical systems;

1.232 Monocular versus binocular pupil size;

1.233 Pupil size: effect of luminance level;

1.234 Pupil size: effect of target distance;

1.614 Visual acuity: effect of pupil size;

1.628 Factors affecting contrast sensitivity for spatial patterns

1.639 Contrast Sensitivity: Effect of Focus Errors

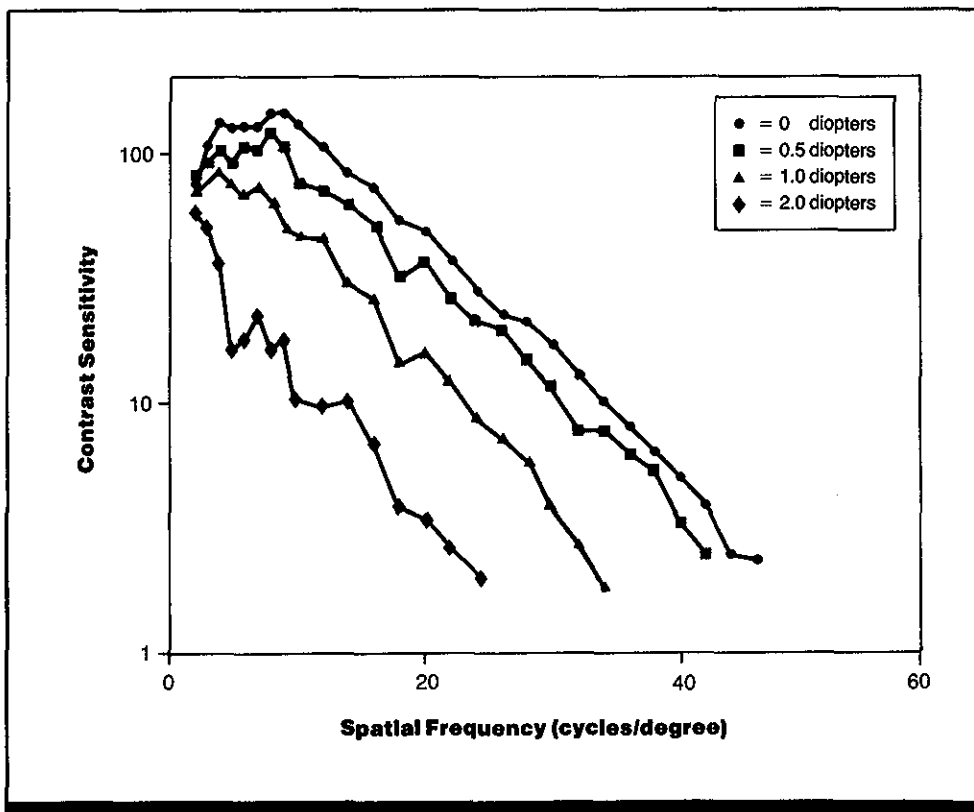

Figure 1. Effect of accommodation errors on contrast sensitivity. Contrast sensitivity is plotted on a log scale against linear spatial frequency. Amount of defocus is given in diopters (1/distance in meters). Top curve represents in-focus viewing. Note that the effect of optical blur on visual acuity can be seen by comparing the relative high-frequency cutoff positions of the contrast sensitivity functions. (From Ref. 1)

Key Terms

Accommodation; contrast sensitivity; eye focus; modulation transfer function; pattern detection; size

General Description

Errors in accommodation (optical focus of the eye) result in a blurred retinal image and degrade contrast sensitivity for bar patterns (sine-wave gratings). Focus errors attenuate the visibility of high spatial frequencies (fine patterns) more than low ones (coarse patterns).

Applications

Tasks entailing visual resolution of fine details or detection of low-contrast targets; design of displays presenting finely detailed imagery.

Methods

Test Conditions

- Sine-wave grating presented via CRT, filling rectangular field 2×1.3 deg; mean luminance 100 cd/m^2 ; equiluminous sur-

- round of unspecified size
- Viewing distance 1.4 m (57 in)
- Monocular viewing; 2-mm artificial pupil
- Accommodation prevented and eye pupil paralyzed by Homatropine
- Grating blur (defocus) of 0.0, 0.5, 1.0, and 2.0 diopters, produced by lenses

Experimental Procedure

- Method of adjustment
- Independent variables: spatial frequency of target, amount of defocus

- Dependent variable: contrast threshold
- Observer's task: adjust target contrast until target just barely detected
- 2 astigmatic observers; data reported were on right eye of 1 observer

Experimental Results

- Blurred (defocused) retinal images resulting from errors of accommodation degrade contrast sensitivity.
- For spatial frequencies greater than ~ 1 -5 cycles/deg, log contrast sensitivity decreases approximately linearly as spatial frequency increases at all levels of defocus. Although absolute contrast sensitivity depends on focus condition, the rate of decrease in contrast sensitivity with spatial frequency varies little regardless of the amount of image blurring.

Variability

No information on variability was given.

Repeatability/Comparison with Other Studies

The reported results are confirmed by those of another study using a similar technique (Ref. 2).

Constraints

- Many factors, such as target orientation, pupil size, and visual-field location, affect contrast sensitivity and must be considered in applying these results under different conditions (CRef. 1.628).

Key References

*1. Campbell, F. W., & Green, D. G. (1965). Optical and retinal factors affecting visual resolution. *Journal of Physiology*, 181, 576-593.

2. Campbell, F. W., Kulikowski, J. J., & Levinson, J. (1966). The effect of orientation on the visual resolution of gratings. *Journal of Physiology*, 181, 427-436.

3. Mitchell, D. E., & Wilkinson, F. (1974). The effect of early astigmatism on the visual resolution of gratings. *Journal of Physiology*, 243, 739-756.

Cross References

1.222 Visual accommodation;
1.603 Factors affecting visual acuity;

1.628 Factors affecting contrast sensitivity for spatial patterns;

1.641 Contrast sensitivity: effect of edge sharpness;

1.642 Contrast sensitivity: effect of border gradient;

Handbook of perception and human performance, Ch. 7, Sect. 4.3

1.640 Contrast Sensitivity: Effect of Viewing Distance and Noise Masking

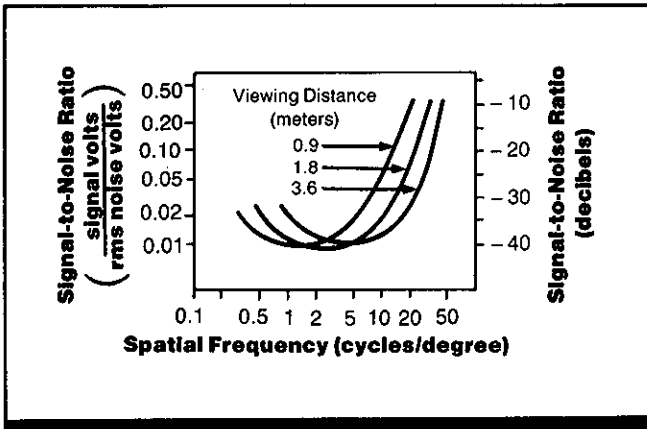

Figure 1. Signal-to-noise ratio at detection threshold as a function of spatial frequency of bar patterns for three viewing distances. (From Ref. 1)

Key Terms

Accommodation; contrast sensitivity; modulation transfer function; pattern detection; size; visual noise

General Description

The detection thresholds for bar patterns (**sine-wave gratings**) of different **spatial frequencies** (bar sizes), (i.e., modulation transfer functions), are affected in complex ways by viewing distance and the presence of visual noise. Greater viewing distance shifts the curves to higher frequencies. Ocular **accommodation** (eye focus) is partly responsible for the effect of viewing distance. The presence of noise has a non-additive effect on detection thresholds relative to thresholds found under signal-only conditions.

Applications

Displays and viewing environments where the visibility of low-contrast targets must be maximized.

Methods

Test Conditions

- Vertical bar patterns (sine-wave gratings) presented on television monitor; luminance levels in photopic range
- Spatial frequency of the bar pattern varied from 0.2-40.0 cycles/deg
- Viewing distance ranged from 0.2-10.0 m (Fig. 2) or 0.9-3.6 m (Fig. 1)
- Noise, when present, consisted of broad-band noise (white noise) of 0-5 MHz signal

Experimental Procedure

- Up and down method of limits; several trials per data point for each subject
- Independent variables: viewing distance, spatial frequency, presence or absence of noise
- Dependent variable: detection threshold for bar pattern, measured as signal-to-noise ratio for noise condition and as signal strength for signal-only condition
- Observer's task: report whether bars were seen at each presentation of a test pattern
- 6 observers

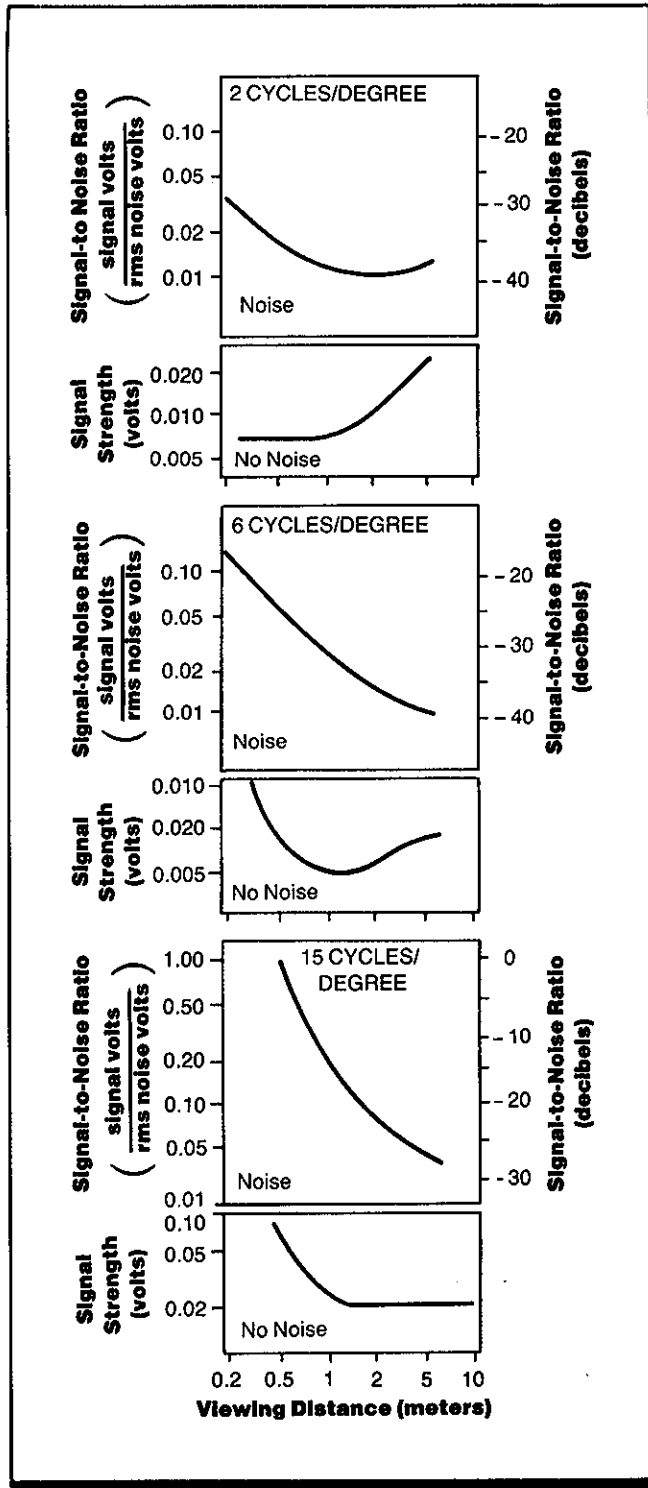

Figure 2. Detection thresholds for bar patterns alone (signal only) and bar patterns presented with broad-band noise as a function of viewing distance for spatial frequencies of 2, 6, and 15 cycles/deg. (From Ref. 1)

Experimental Results

- For bar patterns presented in visual noise, the signal-to-noise ratio at detection threshold varies as a function of spatial frequency of the pattern; the shape of the curves is similar for different viewing distances but, for greater distances, shifts to higher frequencies (Fig. 1).
- In the signal-only condition signal threshold increases (sensitivity decreases) with increasing viewing distance for low spatial frequencies (2 cycles/deg) but the opposite is the case for high spatial frequencies (6 and 15 cycles/deg);

Constraints

- Results may be different for different noise distributions.
- These results are for near-threshold values of contrast; results may be different for high-contrast targets.

Key References

*1. Pollehn, H., & Roehrig, H. (1970). Effect of noise on the modulation transfer function of the visual channel. *Journal of the Optical Society of America*, 60, 842-848.

Cross References

1.615 Visual acuity: effect of viewing distance;
1.616 Visual acuity: effect of viewing distance and luminance level;

these results reflect the effects of ocular accommodation (Fig. 2).

- The presence of broad-band noise does not simply raise pre-existing thresholds but has more complex effects, as can be seen when the signal only and signal-plus-noise panels of Fig. 2 are compared.

Variability

No specific data are provided, but there were relatively small inter- and intrasubject variations as a function of the experimental variables.

-
- Many factors (such as luminance level, orientation, and visual field location) affect contrast sensitivity for spatial patterns and must be considered in applying these results under different viewing conditions (CRef. 1.628).

1.628 Factors affecting contrast sensitivity for spatial patterns;

1.650 Spatial frequency (size) masking

1.641 Contrast Sensitivity: Effect of Edge Sharpness

Key Terms

Contrast sensitivity; edge sharpness; luminance; pattern detection

General Description

Contrast sensitivity for narrow bars with a Gaussian luminance distribution is approximately the same as for narrow rectangular bars. However, contrast sensitivity for wide Gaussian bars is much poorer than for wide rectangular bars; for Gaussian bars wider than ~ 0.2 deg effective width, sensitivity decreases as effective bar width increases, whereas sensitivity for rectangular bars is a constant for bars wider than 0.3 deg. The decrease in contrast sensitivity with increased width for Gaussian bars is due to the loss in edge sharpness as width increases.

Applications

Displays and viewing environments where the visibility of low-contrast targets must be maximized.

Methods**Test Conditions**

- Targets were single, dark, vertical bars with rectangular or Gaussian luminance distribution; Gaussian bar had a luminance profile of e^{-x^2/σ^2} where x is the distance from the center of the bar and σ is the spread factor
- CRT display with 5.5-deg diameter field; display luminance of 100 cd/m² (30 fL)
- Nature of surround not reported
- Binocular viewing with free inspection of screen (i.e., no sug-

gested fixation); test patterns on until threshold sequence completed

Experimental Procedure

- Method of adjustment
- Independent variables: luminance profile of bars (Gaussian or rectangular), effective width of bars (where the effective width of a Gaussian bar is defined as $\sigma\sqrt{\pi}$, so that a Gaussian bar with spread σ will have the same area beneath it as a rectangular bar of width $\sigma\sqrt{\pi}$ at the same contrast; effective width of a rectangular bar equals real width)

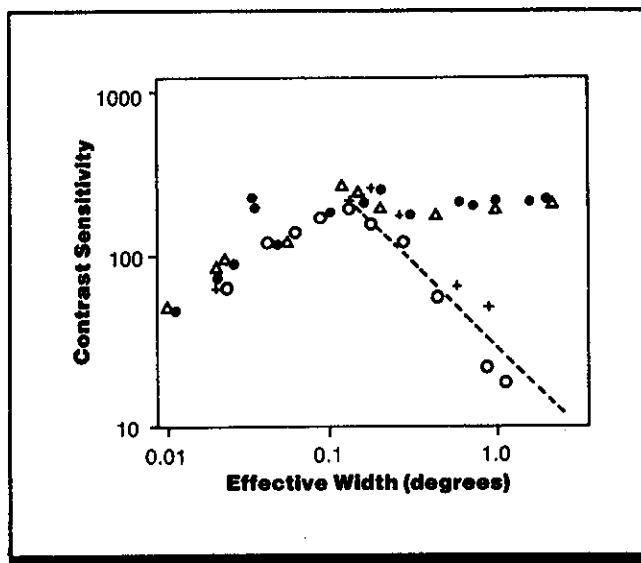

Figure 1. Contrast sensitivity as a function of effective width for rectangular bars (triangles and closed circles) and Gaussian bars (open circles and crosses). Effective width is actual width for rectangular bars and $\sigma\sqrt{\pi}$ (where σ is the spread factor) for Gaussian bars (see "Methods" for further details). Each point represents an average of five to ten observations; data are for 2 observers. The dashed line, which has a slope of -1 , indicates reciprocity of spread (σ) and contrast sensitivity. (From Ref. 5)

- Dependent variable: threshold contrast (mean contrast at which bars were just detectable), where contrast is defined as Michelson contrast; figure plots contrast sen-

- sitivity (reciprocal of threshold contrast)
- Observer's task: adjust contrast of bar until it was just visible
- 2 observers, amount of practice unspecified

Experimental Results

- Contrast sensitivity increases for both rectangular and Gaussian bars as effective bar width increases from 0.01 deg to ~ 0.2 deg.
- Contrast sensitivity for rectangular bars asymptotes at an effective width of ~ 0.3 deg. Contrast sensitivity for Gaussian bars is approximately inversely proportional to effective width for widths > 0.2 deg.
- Therefore, for narrow bars, effective width determines visibility regardless of luminance profile, but for large bars of equal effective width, sharp-edged rectangular bars are detectable at much lower contrast.
- Since the maximum slope of a Gaussian function is inversely proportional to its spread, the visibilities of large Gaussian bars are approximately proportional to the maximum slopes of the bars.

Variability

- Contrast thresholds based on five to ten consecutive readings and had a standard error of 5 percent.

Repeatability/Comparison with Other Studies

The results described here are consistent with those of other studies on sharp-edged bars (Ref. 2), trapezoidal bars (Refs. 3, 6), and rectangular and sinusoidal bars (Ref. 4), but exact conversion to the contrast units used in other studies is difficult. Sensitivities for gratings of < 10 cycles/deg and bars > 0.15 deg reported in Ref. 1 are significantly different from those reported here, and there is no proposed explanation other than possibly a difference in screen size. Given the small number of observers, differences are not surprising.

Constraints

- Results reported apply only to near-threshold values of contrast; results may be different for high-contrast targets.
- Many factors (such as luminance level, orientation, and visual field location) affect contrast sensitivity for spatial patterns and must be considered in applying these results under different viewing conditions (CRef 1.628).

Key References

- | | | |
|--|--|---|
| <p>1. Campbell, F. W., Carpenter, R. H. S. C., & Levinson, J. Z. (1969). Visibility of aperiodic patterns compared with that of sinusoidal gratings. <i>Journal of Physiology</i>, 204, 283-298.</p> | <p>2. Fry, G. A. (1970). The optical performance of the human eye. <i>Progress in Optics</i>, 8, 51-131.</p> <p>3. Hood, D., & Whiteside, J. (1968). Brightness of ramp stimuli as a function of plateau and gradient widths. <i>Journal of the Optical Society of America</i>, 58, 1310-1311.</p> | <p>4. Kulikowski, J. J., & King-Smith, P. E. (1973). Spatial arrangement of line, edge, and grating detectors revealed by subthreshold summation. <i>Vision Research</i>, 13, 1455-1478.</p> <p>*5. Shapley, R. (1974). Gaussian bars and rectangular bars: The influence of width and gradient on visibility. <i>Vision Research</i>, 14, 1457-1462.</p> <p>6. Thomas, J. P., & Kovar, C. (1965). The effect of contour sharpness on perceived brightness. <i>Vision Research</i>, 5, 559-564.</p> |
|--|--|---|

Cross References

- 1.628 Factors affecting contrast sensitivity for spatial patterns;
- 1.642 Contrast sensitivity: effect of border gradient

1.642 Contrast Sensitivity: Effect of Border Gradient

Key Terms

Contrast sensitivity; edge sharpness; pattern detection; size

General Description

Contrast sensitivity for a sine-wave grating (bar pattern) is greatest (i.e., contrast thresholds are lowest) at spatial frequencies between 1 cycle/deg and 3 cycles/deg; sensitivity is lower at lower and higher spatial frequencies (Fig. 1). At low spatial frequencies, contrast thresholds are determined in part by the luminance gradient between adjacent light and dark bars, which is related to the effect of blurring the border between light and dark halves of a split field (an edge). For a single edge, contrast threshold is independent of the border gradient when gradients are steep (equivalent to higher spatial frequencies) and thus blur is small.

Applications

Displays and viewing environments where the visibility of low-contrast targets must be maximized.

Methods**Test Conditions**

- Vertically oriented single edge, or sine-wave grating with spatial frequency from 0.2-18 cycles/deg
- Display field 5.08 cm wide by 2.54 cm high
- Average luminance of targets was 74.3 cd/m² (21.7 fL); large equiluminous (74.3 cd/m²) surround lighted by fluorescent illumination
- Observer's head supported by chin cup; lens used to correct re-

fraction for each observer; monocular viewing; artificial pupil used, size not reported

Experimental Procedure

- Method of adjustment
- Independent variables: spatial frequency of grating equivalent to spatial frequency of edges (defined as the spatial frequency of a grating with a border luminance gradient equal to that of the edge)
- Dependent variable: Contrast threshold (contrast between light and dark areas of target at which

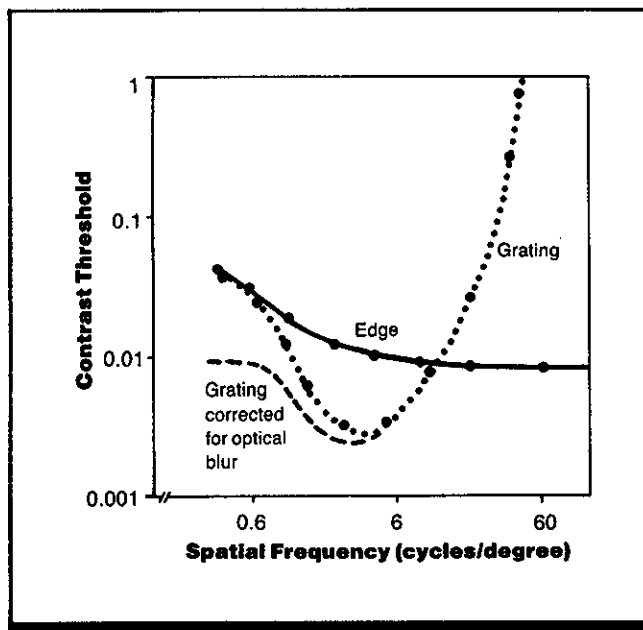

Figure 1. Contrast threshold as a function of spatial frequency for sine-wave gratings and single edges of equivalent spatial frequency. Dashed line shows grating results corrected for optical blur. (From Ref. 3)

target was just detectable), where contrast is defined as Michelson contrast; Fig. 1 plots contrast sensitivity (reciprocal of contrast threshold)

- Observer's task: adjust contrast of the target to make it just detectable
- 1 observer with extensive practice

Experimental Results

- Contrast thresholds are lowest (sensitivity is greatest) for sine-wave gratings with spatial frequencies between 2 and 6 cycles/deg. Both higher and lower frequencies yield higher thresholds, with a rapid increase for higher frequencies.
- A single edge can be compared to a grating in terms of the slope of the gradient between the areas of maximum and minimum luminance (defining the sharpness or blurredness of the border). Contrast thresholds for a single edge are relatively independent of border gradient (amount of blur) for relatively steep gradients (>4 cycles/deg equivalent spatial frequency). Threshold increases as border gradient, and thus equivalent spatial frequency, decreases (i.e., as blur increases) for shallower gradients.

- The fact that the contrast threshold for edge targets depends on the slope of the luminance gradient only at low equivalent spatial frequencies suggests that the upturn in contrast threshold for sine-wave gratings at low spatial frequencies is due at least in part to optical blur at these frequencies. The dashed line in Fig. 1 shows the threshold function for sine-wave gratings corrected for optical blur.

Variability

No information on variability was given.

Repeatability/Comparison with Other Studies

The contrast sensitivity functions described here are very similar in form to those obtained in other studies. Precise values of spatial frequencies at which peak sensitivity occurs vary slightly from study to study with varying conditions (Refs. 1, 2, 4; CRef. 1.632).

Constraints

- Results reported apply only to near-threshold values of contrast; results may be different for high-contrast targets.
- Many factors (such as luminance level, orientation, and visual field location) affect contrast sensitivity for spatial patterns and must be considered in applying these results under different viewing conditions (CRef. 1.628).

Key References

- | | | | |
|--|---|--|---|
| 1. Campbell, F. W., & Green, D. G. (1965). Optical and retinal factors affecting visual resolution. <i>Journal of Physiology</i> , 181, 576-593. | 2. Campbell, F. W., & Robson, J. G. (1968). Application of Fourier analysis to the visibility of gratings. <i>Journal of Physiology</i> , 197, 551-566. | *3. Fry, G. A. (1969). Visibility of sine-wave gratings. <i>Journal of the Optical Society of America</i> , 59, 610-617. | 4. Westheimer, G. (1960). Modulation thresholds for sinusoidal light distribution on the retina. <i>Journal of Physiology</i> , 152, 67-74. |
|--|---|--|---|

Cross References

- | | |
|--|--|
| 1.628 Factors affecting contrast sensitivity for spatial patterns; | 1.632 Contrast sensitivity: effect of luminance level (foveal vision); |
| 1.631 Contrast sensitivity: effect of number of luminance modulation cycles and luminance level; | 1.641 Contrast sensitivity: effect of edge sharpness |

1.643 Contrast Sensitivity: Effect of Target Shape and Illumination Level

Target Description		Target Size (minutes of arc)	
		Detail	Overall
●	Disc	3.9	3.9
C	Landolt C	4.0	20.0
	Cobb 2-bar	4.0	12.0
	Line	1.2	20.8
•••••	Dot pattern	1.0	42.5
	Grating	3.9	42.7
e	Printed e	2.2	15.8
ℓ	Script	3.2	35
U P S E R	Test chart letters	4.0	20.1

Figure 1. Targets used to measure target detection and detail resolution. Overall size refers to overall target dimensions; detail size refers to the size of target critical detail, such as size of gap in Landolt C, distance between double bars, grating bar width, letter stroke width, etc. (From Ref. 5)

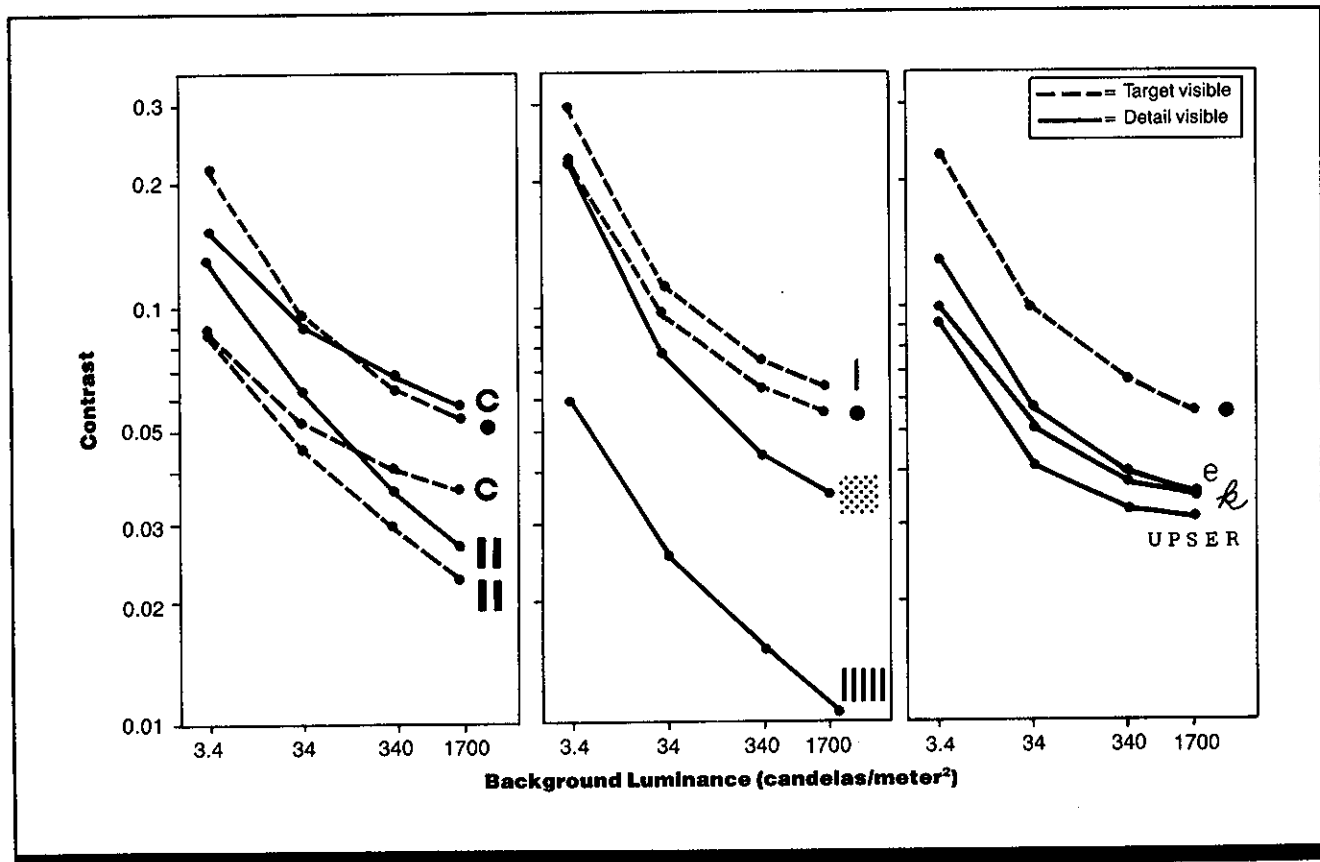

Figure 2. Threshold for various targets as a function of background luminance; data for disc are included in each panel for comparison. Data are shown for detection task (judge whether target present) and resolution task (judge whether target detail visible). Overall size and critical detail size for each target are given in Fig. 1. (From Ref. 5)

Key Terms

Contrast sensitivity; pattern detection; shape; spatial resolution; target complexity; visual acuity

General Description

As background luminance increases, the minimum contrast needed to detect a target's presence or to judge its detail decreases. The configuration of the target affects the steepness of the decline in threshold with background luminance as well as its absolute value. More complex targets tend to have lower contrast thresholds.

Applications

Measurement of visual performance; displays and viewing environments where the visibility of low-contrast targets or target detail must be maximized.

Methods

Test Conditions

- Illuminated targets and immediate background projected for 200 msec by optical device to center of screen extending 64 deg of visual angle vertically and 86 deg horizontally
- 13 test targets of varying complexity presented individually; Fig. 1 provides target description and size
- Target always brighter than background; background luminance from 3.4-1700 cd/m²
- Viewing distance of 1 m

Experimental Procedure

- Up-and-down method of limits
- Independent variables: type of target, background luminance
- Dependent variable: contrast threshold (minimum target contrast at which target is judged present or its detail is visible); contrast presumably defined as incremental target luminance above background luminance divided by background luminance (contrast ratio) but not specified
- Observer's task: report presence of target or presence of detail
- 2 highly practiced observers

Experimental Results

- Contrast threshold decreases as background luminance increases.
- Highest and lowest curves in Fig. 2 differ significantly from each other, but none of the curves differs significantly from that for the disc target.
- A target can be detected at a lower contrast than is required to discern its detail.
- There are some differences among targets of different complexity both in absolute contrast thresholds and in the steepness of the decline in threshold with increasing back-

Constraints

- Target complexity is not well defined.
- These results are for near-threshold values of contrast; results may be different for high-contrast targets.
- Many factors (such as luminance level, orientation, and visual field location) affect contrast and acuity (detail reso-

Key References

1. Blackwell, H. R. (1966). *IES lighting handbook* (4th ed.). New York: Illuminating Engineering Society.

2. Cobb, P. W., & Moss, F. K. (1928). Four fundamental factors in vision. *Illumination Engineering Society Transactions*, 22, 496-506.

3. Conner, J. P., & Ganoung, R. E. (1935). An experimental determination of the visual thresholds of

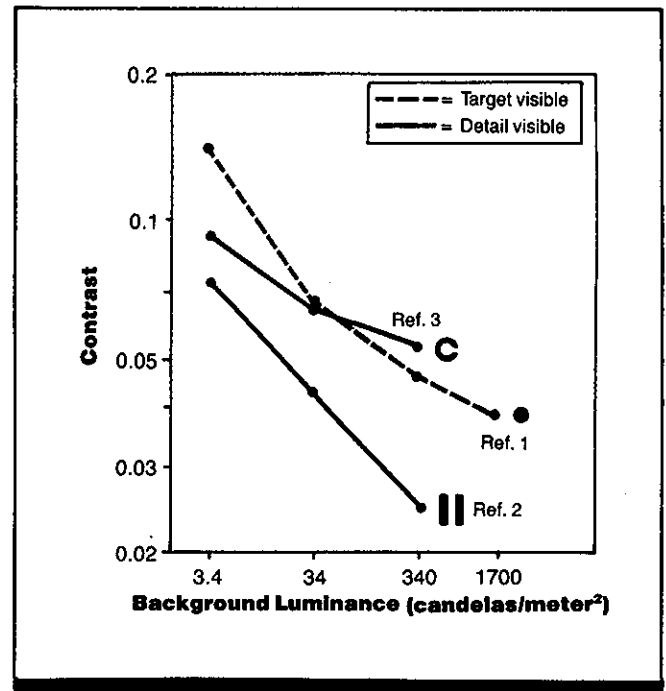

Figure 3. Contrast threshold for various targets as a function of background luminance: comparison data from three studies. Observer's task (Ref. 1) for a 4-min-arc disc involved detecting presence of target; tasks for Refs. 3 and 4 were discrimination of detail for a 4.5-min-arc Landolt C and 3.95-min-arc parallel bars, respectively. (From Ref. 5)

ground luminance, although most of the differences do not exceed a contrast ratio of 2 to 1. Generally, the greater the complexity of the target, the lower the threshold, grating targets yielding the lowest thresholds.

Variability

No information on variability was given.

Repeatability/Comparison with Other Studies

For comparison, data from other relevant studies are plotted in Fig. 3. Characteristics of the curves are similar to those in Fig. 2.

lution) for spatial patterns and must be considered in applying these results under different viewing conditions (CRefs. 1.628, 1.603).

- Targets were always brighter than the background; authors state that relationships also hold for targets that are darker than their backgrounds.

low values of illumination. *Journal of the Optical Society of America*, 15, 287-294.

4. Farrell, R. J., & Booth, J. M. (1984). *Design handbook for imagery interpretation equipment*. Seattle, WA: Boeing Aerospace.

*5. Guth, S. K., & McNelis, J. F. (1969). Threshold contrast as a function of target complexity. *Archives of the American Academy of Optometry*, 46, 98-103.

Cross References

1.603 Factors affecting visual acuity;

1.625 Target detection: effect of target spatial dimensions;

1.628 Factors affecting contrast sensitivity for spatial patterns;

1.632 Contrast sensitivity: effect of luminance level (foveal vision);

1.633 Contrast sensitivity: effect of luminance level (peripheral vision)

1.644 Contrast Sensitivity for Snellen Letters

Key Terms

Contrast sensitivity; pattern detection; pattern resolution; spatial filtering; visual acuity

General Description

One standard test of visual acuity is the ability of observers to resolve **Snellen letters** of various sizes. When the minimum contrast required for observers with normal (or corrected-to-normal) vision to detect and identify Snellen letters is measured as a function of letter size expressed in terms of spatial frequency, the **contrast sensitivity function** obtained is very similar in shape to contrast sensitivity functions as conventionally measured with bar patterns (**sine-wave gratings**) (e.g., CRefs. 1.632, 1.645). Thus, contrast sensitivity functions and traditional Snellen measures of visual acuity are comparable. Although there has not been extensive work in this area, individual Snellen acuity can be predicted from individual contrast sensitivity functions. The results show modest success for a group of individuals with a variety of optical abnormalities.

Applications

Measurement of visual acuity.

Methods

Test Conditions

- Snellen letters low-pass filtered (between 0.5 and 3.0 cycles per letter width) to determine fundamental frequency (minimum number of cycles for identification) for each letter
- Snellen chart presented by projecting 35-mm slide on matte surface
- Standard 6-m distance, 68.5 cd/m² luminance
- Contrast controlled by a crossed polaroid system that permitted continuous variation in contrast
- Snellen letters to be read were indicated by adjacent blue markers

Experimental Procedure

- Staircase procedure
- Independent variables: stimulus contrast, Snellen line number
- Dependent variable: detection threshold, defined as lowest contrast at which any inhomogeneity can be seen in the otherwise uniform stimulus field on 50% of trials; identification threshold, defined as lowest contrast at which 50% accuracy in letter identification is achieved
- Subject's task: indicate whether any inhomogeneity is present between blue markers (detection task); identify letters present on line (identification task)
- 5 subjects with normal or corrected-to-normal vision of 6/6 or better

Experimental Results

- Average contrast sensitivity (reciprocal of contrast threshold) for detection and identification of Snellen letters as a function of letter size is presented in Fig. 1.
- Contrast sensitivity is relatively constant for Snellen lines 6/60-6/18; this is consistent with the relatively flat contrast sensitivity found in the low to middle range of spatial frequencies as measured by conventional contrast sensitivity tests using sine-wave gratings.
- Detection and identification thresholds are fairly close in 6/60-6/36 range, the bandwidth where human sensitivity is greatest.

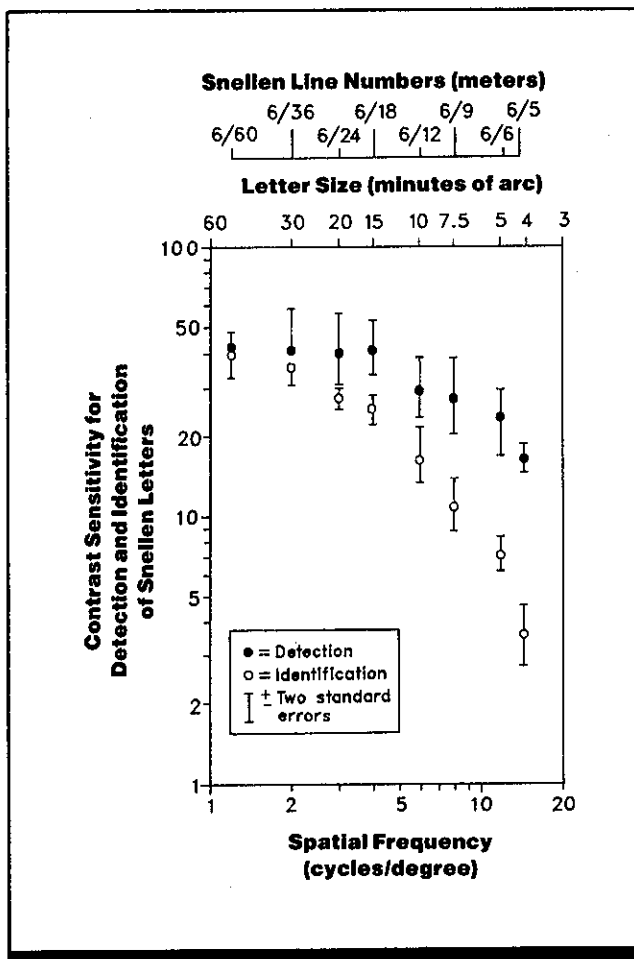

Figure 1. Contrast sensitivity for the detection and identification of at least 50% of the letters on each line of a standard Snellen chart. Snellen letter sizes are given in terms of Snellen line, visual angle subtended by the letter in minutes of arc, and spatial frequency. Snellen lines are given in meters; lines 6/60 and 6/6 are similar to lines 20/200 and 20/20 measured in feet. Letters in line 6/6 can be resolved by a person with normal vision at a distance of 6 m. (From Ref. 1)

- At the smallest letter sizes, identification performance declines and the difference between detection and identification functions increases; these results are consistent with human contrast sensitivity data obtained with bar patterns.
- In a related study, 11 subjects who had a variety of visual abnormalities (amblyopia and multiple sclerosis) performed standard contrast sensitivity tasks and Snellen tasks. Snellen acuity was predicted from measured contrast sensitivity functions. Agreement between predicted and obtained Snellen acuity was perfect for 8 of 22 eyes (36.4%); 16 of 22 eyes (72.7%) were predicted within one Snellen line.

Variability

Error bars showing ± 2 standard errors are given in Fig. 1.

Constraints

- The number of letters on a Snellen line is not constant; fewer letters are present on larger lines. Thus, 50% thresholds do not represent the same level of performance for different lines of the chart (Ref. 1).

- Many factors (such as luminance level, orientation, and visual field location) affect contrast sensitivity for spatial patterns and must be considered in applying these results under different viewing conditions (CRef. 1.628).

Key References

*1. Ginsburg, A. P. (1978). *Visual information processing based on spatial filters constrained by biological data*. Unpublished doctoral dissertation, University of Cambridge, England (also published as AFAMRL-TR-78-129). (DTIC No. ADA090117)

2. Ginsburg, A.P. (1980). Specifying relevant spatial information for image evaluation and display design: An explanation of how we see certain objects. *Society for Information Display*, 21, 219-227.

3. Ginsburg, A. P. (1981). Spatial filtering and vision: Implications for normal and abnormal vision. In L. M. Proenza, J. M. Enoch, & A. Jampolski (Eds.), *Clinical applications of visual psychophysics* (pp. 70-106). Cambridge, England: Cambridge University Press.

Cross References

1.603 Factors affecting visual acuity;
1.628 Factors affecting contrast sensitivity for spatial patterns;

1.632 Contrast sensitivity: effect of luminance level (foveal vision);

1.645 Contrast sensitivity for a large population sample;

1.647 Contrast matching;

6.312 Form perception: contribution of different spatial-frequency bandwidths;

Handbook of perception and human performance, Ch. 34, Sect. 10.1

1.645 Contrast Sensitivity for a Large Population Sample

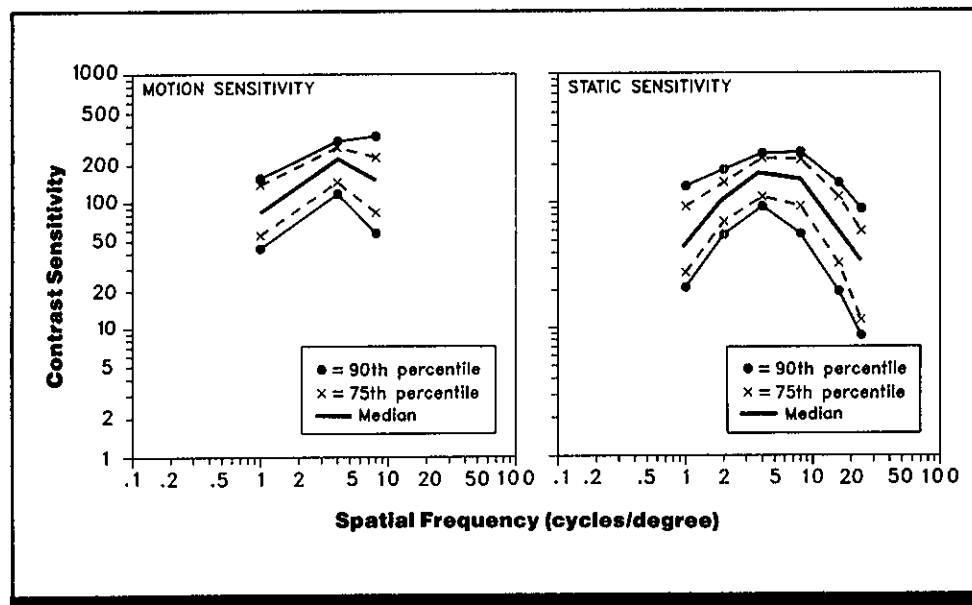

Figure 1. Contrast sensitivity for moving and stationary gratings. The heavy solid line in the center plots values for the median (50th percentile). The region between the two dashed lines encompasses contrast sensitivity limits for 75% of the sampled population, and the area between the outer solid lines encloses 90% of the sampled population. (From Ref. 3)

Key Terms

Contrast sensitivity; modulation transfer function; pattern detection; size

General Description

When contrast sensitivity is measured for a large population sample, sensitivity for both moving and stationary bar patterns (**sine-wave gratings**) is found to be greater for medium-width bars (mid range **spatial frequencies**) than for coarser (lower frequency) or finer (higher frequency) bars. Contrast sensitivity peaks at a spatial frequency of ~ 4 cycles/deg. Target motion enhances contrast sensitivity, but only at lower spatial frequencies. Individual differences in

contrast sensitivity are greatest at the lowest and highest spatial frequencies.

Because contrast sensitivity functions provide information regarding visual abilities for a wide range of target sizes, they may allow better prediction of visual performance than standard acuity tests.

Despite normal **visual acuity**, 10-15% of the population is estimated to have low **contrast sensitivity** for low and middle range spatial frequencies (1-8 cycles/deg) (Ref. 3).

Applications

Displays and viewing environments where the visibility of low-contrast targets must be maximized.

Methods

Test Conditions

- Targets: static and moving vertical sine-wave gratings presented on video screen; target size 4×5 deg of visual angle; mean luminance of 60 cd/m^2
- Moving targets shifted to right in 5 deg/sec steps

- Spatial frequencies: 1, 4, 8, 16, 24 cycles/deg for static patterns; 1, 4, 8 cycles/deg for moving grating patterns
- Contrast increased at a rate of 0.14% per sec
- Portable microprocessor-controlled unit presented test patterns
- Viewing distance: 2.74 m
- Practice preceded actual trials

- Three trials per person
- Total average testing time: 12 min

Experimental Procedure

- Ascending method of limits (method of increasing contrast)
- Independent variables: spatial frequency of bar patterns, static versus dynamic test pattern

- Dependent variable: contrast threshold (mean contrast at which bar pattern just became visible)
- Observer's task: press button when target becomes visible
- 265 inexperienced observers, mean ages 37.5 yr; screened for normal vision and acuity (via **Sloan letter chart**) and absence of ophthalmic pathology

Experimental Results

- Contrast sensitivity varies with spatial frequency, peaking at ~4 cycles/deg.
- For moving targets, contrast sensitivity is enhanced at low spatial frequencies (1-3 cycles/deg).

Variability

Individuals with similar visual acuity may differ significantly in contrast sensitivity (standard deviation of ~3). Figure 1 provides contrast sensitivity values for median (50th), 75th, and 90th percentiles. Variability is greatest at the lowest and highest spatial frequencies.

Constraints

- Contrast sensitivity is influenced by many factors, including measurement technique (Ref. 2), test conditions, and practice (Ref. 1), which must be considered in applying these data under specific viewing conditions (CRefs. 1.628).
- Contrast sensitivity for different population subgroups (pilots, young adults, senior citizens, etc.) is likely to differ from measurements for the general population.

Repeatability/Comparison with Other Studies

Retest at 6 months with atypical sample of 6 observers gave results not significantly different from original measurements. The shapes of the data curves found here conform to those obtained in laboratory studies using smaller samples (e.g., Ref. 1; CRefs. 1.629, 1.632). Reference 2 found contrast sensitivity strongly positively related to pilot performance on flight simulators. Reference 2 claims that the method of increasing contrast (ascending limits) is superior to two other psychophysical methods for determining contrast sensitivity (method of adjustment and Békésy tracking).

- Large variability for static patterns at high spatial frequencies is thought to be due to differences in individual refractive state; the cause for variability at low frequencies is unknown but may be related to the number of bars present.
- The stability of an individual's contrast sensitivity over long periods and different tasks has not been adequately tested.

Key References

1. Ginsburg, A. P. (1981). Spatial-filtering and vision: Implications for normal and abnormal vision. In L. M. Proenza, J. M. Enoch, & A. Jampolsky (Eds.). *Applications of psychophysics to clinical problems*. (Proceedings of the Symposium held in San Francisco, CA, Oct. 1978, pp. 70-106).

Cambridge, England: The Cambridge University Press.

2. Ginsburg, A. P., & Cannon, M. W. (1983). Comparison of three methods for rapid determination of threshold contrast sensitivity. *Investigative Ophthalmology and Visual Science*, 24, 789-802.

*3. Ginsburg, A. P., Evans, D. W., Cannon, M. W., Owsley, C., & Mulvanny, P. (1984). Large-scale norms for contrast sensitivity. *American Journal of Optometry and Physiological Optics*, 61, 80-84.

Cross References

1.628 Factors affecting contrast sensitivity for spatial patterns;

1.629 Contrast sensitivity: effect of field size;

1.632 Contrast sensitivity: effect of luminance level (foveal vision);

1.637 Contrast sensitivity: effect of target motion;

1.644 Contrast sensitivity for Snellen letters;

Handbook of Perception and Human Performance, Ch. 34, Sect. 11

1.646 Contrast Discrimination

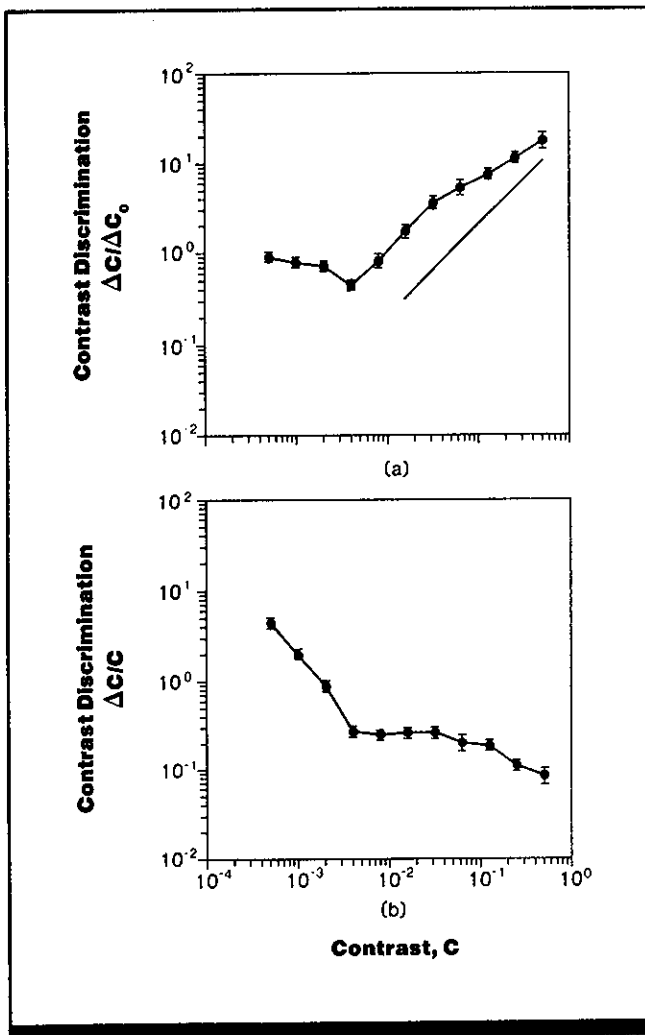

Figure 1. Contrast discrimination thresholds for a 2-cycle/deg sine-wave grating as a function of reference contrast (C). (a) Smallest detectable increment in contrast, ΔC , as a proportion of detection threshold, ΔC_0 (contrast required for detection against a uniform field, i.e., when $C = 0$). The heavy diagonal line shows the rate of increase indicated by Weber's law, which holds that $\Delta C/C = \text{a constant}$. (b) Smallest detectable increment in contrast, ΔC , as a proportion of reference contrast, C. Data in strict accordance with Weber's law would fall on a horizontal line. (From Ref. 2)

Key Terms

Contrast discrimination; contrast sensitivity

General Description

The contrast difference threshold (the smallest difference in contrast, ΔC , that allows a test grating or bar pattern to be distinguished from a reference grating) varies depending on the contrast of the reference grating. For most reference contrasts, the contrast difference threshold increases when

expressed as a proportion of absolute contrast threshold (smallest contrast that allows a bar pattern to be distinguished from a uniform field) (Fig. 1a). The contrast difference threshold ΔC represents an increasingly smaller proportion of the reference contrast as the reference contrast increases (Fig. 1b).

Applications

Displays and viewing environments where the visibility of low-contrast targets must be maximized.

Methods

Test Conditions

- Vertical sine-wave gratings were presented on a cathode ray tube with a space-averaged luminance of 200 cd/m²; gratings 6 deg wide and 6 deg high.
- Two 200-ms exposure intervals marked by tones and separated by

750 ms; one interval contained reference grating with percentage contrast of 0.05-51.2; other interval contained test grating with variable contrast above or below reference contrast; interval containing reference contrast varied randomly

- Spatial frequency of both reference and test gratings was 2.0 cycles/deg

Experimental Procedure

- Staircase procedure, two-interval forced-choice paradigm
- Independent variables: contrast of reference grating
- Dependent variable: contrast discrimination threshold, defined as the increment in contrast which could be detected on 79 percent of trials

- Observer's task: indicate which interval contained the target of higher contrast
- Each threshold estimate based on six staircase reversals; threshold is geometric mean of four to six threshold estimates
- 3 observers

Experimental Results

- Figure 1a plots the contrast discrimination threshold for a sine-wave grating pattern in terms of the contrast increment ΔC detectable on 79 percent of trials as a proportion of grating contrast at absolute threshold ΔC_0 (i.e., minimum contrast discriminable from a uniform field). When considered in this way, contrast discrimination threshold increases as reference contrast increases for reference contrasts greater than ~ 0.003 (~ 0.5 percent), but actually decreases somewhat with reference contrast for contrasts below this level.
- Figure 1b plots contrast discrimination threshold in terms of the smallest detectable increment ΔC as a proportion of the reference contrast level C , that is, $\Delta C/C$. This propor-

tion is known as the Weber ratio. The Weber ratio decreases as the reference contrast increases, but the decline is much faster for lower reference contrasts.

- The Weber ratio for contrast discrimination is < 0.3 at most reference contrasts, and < 0.1 at higher contrasts.

Variability

Error bars in figure show ± 1 standard error of the mean.

Repeatability/Comparison with Other Studies

Many of these results are confirmed elsewhere (Refs. 1, 3, 4).

Constraints

- The negative slope in the function at low reference contrasts (Fig. 1a) has also been found with aperiodic targets (Ref. 3).

- Many factors (such as luminance level, orientation, and visual field location) affect contrast sensitivity for spatial patterns and must be considered in applying these results under different viewing conditions (CRef. 1.628).

Key References

1. Legge, G. E. (1980). In search of Weber's law for contrast discrimination. *Investigative Ophthalmology and Visual Science*, 19 (Suppl.), 43.
- *2. Legge, G. E., & Foley, J. M. (1980). Contrast masking in human

vision. *Journal of the Optical Society of America*, 70, 1458-1471.

3. Nachmias, J., & Kocher, E. C. (1970). Visual detection and discrimination of luminance increments. *Journal of the Optical Society of America*, 69, 382-389.

4. Nachmias, J., & Sansbury, R. V. (1974). Grating contrast: Discrimination may be better than detection. *Vision Research*, 14, 1039-1042.
5. Strohmeyer, C. F., & Klein, S. (1974). Spatial frequency channels

in human vision as asymmetric (edge) mechanisms. *Vision Research*, 14, 1409-1420.

6. Tolhurst, D. J., & Barfield, L. P. (1978). Interactions between spatial frequency channels. *Vision Research*, 18, 951-958.

Cross References

- 1.401 Brightness difference threshold: effect of background luminance;
- 1.402 Brightness difference threshold: effect of background luminance and duration of luminance increment;

1.628 Factors affecting contrast sensitivity for spatial patterns;

1.647 Contrast matching;

Handbook of perception and human performance, Ch. 7, Sect. 3.1

1.647 Contrast Matching

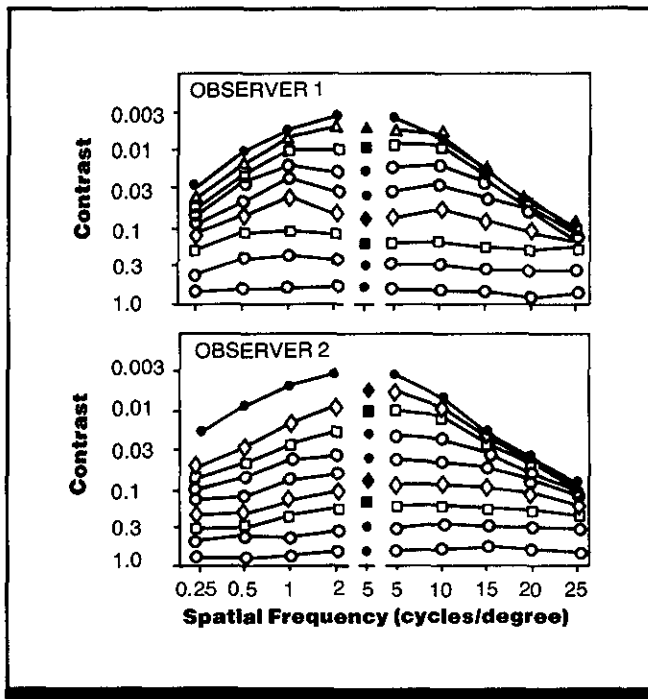

Figure 1. Equal-contrast contours for 2 observers. Filled unconnected symbols show contrast for reference grating; matching open connected symbols show the contrasts of test gratings of different spatial frequencies that matched the corresponding reference grating in apparent contrast. Filled connected circles show the contrast sensitivity function (minimum contrast required for detection). Note that contrast increases from bottom to top along the ordinate. Because of asymmetry of results, spatial frequencies < 5 cycles/deg are plotted on a logarithmic axis and those > 5 cycles/deg on a linear axis. (From Ref. 2)

Key Terms

Contrast matching; contrast sensitivity; pattern detection; size

General Description

Contrast-matching functions describe the effective luminance modulation necessary to match **sine-wave gratings** (bar patterns) of different **spatial frequencies** (bar widths) to a reference grating so that the test and reference gratings appear equivalent in contrast. By choosing a range of reference gratings with different physical contrasts, one can generate a series of isocontrast (apparent by equal contrast)

curves across spatial frequencies (Fig. 1). These curves resemble the **contrast sensitivity function** at low contrasts with loss of sensitivity at high and low spatial frequencies; however, they flatten out at higher physical contrasts where apparent contrast corresponds more closely to physical contrast. These results are largely independent of average luminance and location in the field of view.

Applications

Estimation of apparent contrast from physical contrast.

Methods

Test Conditions

- Vertical sine-wave reference grating (5 cycle/deg) presented at one of eight physical contrasts (See Fig. 1)
- Vertical sine-wave test gratings (0.25, 0.5, 1, 2, 5, 10, 15, 20, 25 cycles/deg) presented with variable contrast to be adjusted by observer

- Reference and test gratings presented on adjacent oscilloscope screens, one test grating per trial; gratings had mean luminance of 10 cd/m², except where stated
- Viewing distance 229 cm for test gratings of 5-25 cycles/deg; screens subtended 2 deg and were separated by 1.5 deg
- Viewing distance 57 cm for test gratings of 0.25-2 cycles/deg; screens subtended 8 deg and were separated by 6 deg

- **Monocular** viewing with preferred eye; head steadied by bite bar
- Threshold settings also taken for each grating

Experimental Procedure

- Method of adjustment with reference contrasts presented in either ascending or descending order; trials blocked by spatial frequency

- Independent variable: spatial frequency of test grating
- Dependent variable: contrast of test grating at which it appears equal in contrast to reference grating
- Observer's task: adjust contrast of test grating until it appeared to match that of reference grating
- 2 observers with extensive practice

Experimental Results

- The depth of luminance modulation (physical contrast) required to match a low-contrast reference grating is higher for bar patterns of low and high spatial frequencies than for bar patterns for ~ 2 -5 cycles/deg.
- At low reference contrasts, contrast-matching functions are similar in shape to the contrast sensitivity function (minimum contrast required for detection of each spatial frequency).

- As the contrast of the reference grating increases, the contrast-matching curves flatten, i.e., all spatial frequencies are roughly equal in apparent contrast when they have the same physical contrast.

Variability

Results are similar for both observers; no specific information on variability reported.

Repeatability/Comparison with Other Studies

Similar results have been obtained in other studies using similar methodology (Refs. 3, 6.)

Constraints

- Individual differences have been reported, particularly in individuals with **astigmatisms**; there are residual losses in apparent contrast despite optical correction (Ref. 1).

- Many factors (such as luminance level, orientation, and visual field location) affect contrast sensitivity for spatial patterns and must be considered in applying these results under different viewing conditions. (CRef. 1.628)

Key References

1. Blakemore, C., Muncey, J. P. J., & Ridley, R. M. (1973). Stimulus specificity in the human visual system. *Vision Research*, 13, 1915-1931.

*2. Georgeson, M. A., & Sullivan, G. O. (1975). Contrast constancy: Deblurring in human vision by spatial frequency channels. *Journal of Physiology*, 252, 627-656.

3. Ginsburg, A. P. (1978). *Visual information processing based on spatial filters constrained by biological data*. Doctoral dissertation, University of Cambridge, England. (Also published as AFAMRL-TR-78-129-VOL-1/2) (DTIC No. ADA090117)

4. Kulikowski, J. J. (1976). Effective contrast constancy and linearity of contrast sensation. *Vision Research*, 16, 1419-1431.

5. Swanson, W. H., Wilson, H. R., & Giese, S. C. (1984). Contrast matching data predicted from contrast increment thresholds. *Vision Research*, 24, 63-75.

6. Watanabe, A., Mori, T., Nagata, S., & Hiwatashi, K. (1968). Spatial sine-wave responses of the human visual system. *Vision Research*, 8, 1245-1263.

Cross References

1.628 Factors affecting contrast sensitivity for spatial patterns;

1.632 Contrast sensitivity: effect of luminance level (foveal vision);

1.645 Contrast sensitivity for a large population sample;

1.646 Contrast discrimination

1.648 Spatial Frequency (Size) Discrimination

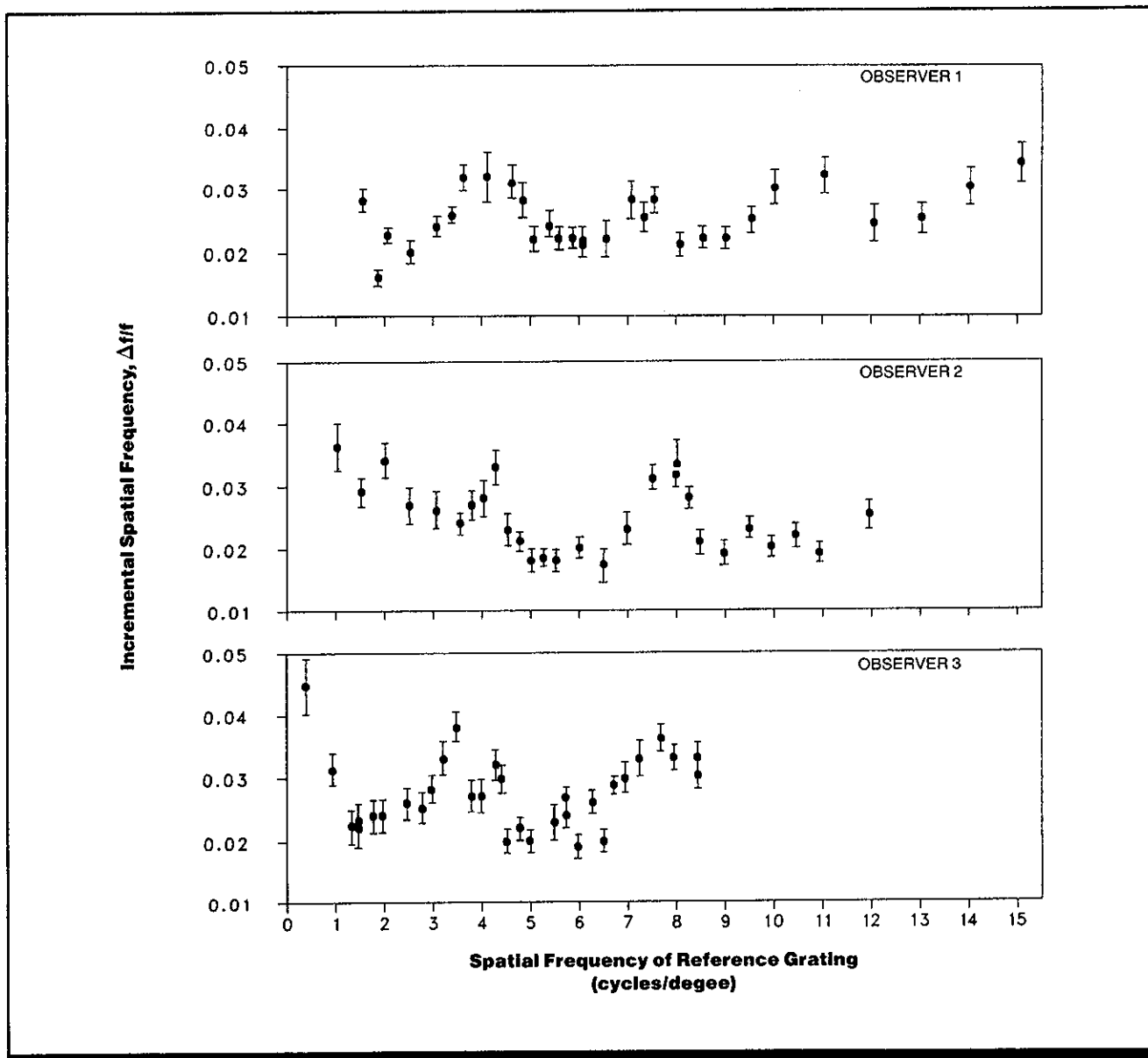

Figure 1. Spatial frequency discrimination as a function of reference spatial frequency. Results are plotted as the Weber ratio $\Delta f/f$, where f is the spatial frequency of a reference grating and Δf is the smallest difference in spatial frequency that can be discriminated from the reference. Data are shown for three observers. (From Ref. 2)

Key Terms

Pattern perception; size discrimination; spatial frequency discrimination

General Description

The minimum difference in **spatial frequency** (bar width) required to correctly distinguish a reference **sine-wave grating** (bar pattern) from a target grating is roughly a constant fraction (~ 0.025) of the spatial frequency of the reference grating.

Methods

Test Conditions

- Vertical sine-wave luminance gratings generated on a cathode-ray tube masked to 12 deg of visual angle diameter; average luminance of display 20 cd/m²; display surround matched in hue and intensity
- Viewing at 150 cm in a dim room; observers dark-adapted 5 min prior to testing

- Reference grating presented at 0.3 Michelson contrast; target gratings presented at matched apparent contrast
- Reference and test gratings presented for 1.5 sec each with a 0.75-sec blank interval; reference grating always presented first
- Seven test gratings presented with each reference grating: three higher, three lower, one the same spatial frequency

- Corrective feedback provided
- 350 trials per point

Experimental Procedure

- Method of constant stimuli; two-alternative forced-choice paradigm; randomized design
- Independent variable: spatial frequency of reference grating
- Dependent variable: spatial frequency difference threshold, defined as the Weber ratio $\Delta f/f$, where f is the reference spatial frequency

and Δf is the smallest difference in spatial frequency that could be discriminated from the reference frequency (determined by 75% response level on fit of cumulative normal psychometric function to the data)

- Observer's task: indicate whether test grating (second grating presented) was higher or lower in spatial frequency than reference grating (first grating presented)
- 3 observers with normal vision

Experimental Results

- The smallest detectable difference in spatial frequency (Δf) between a reference grating and a test grating is, on average, ~ 0.025 of the spatial frequency of the reference (f): i.e., $\Delta f/f \sim 0.025$.
- For all observers, difference thresholds fluctuate regularly and consistently with the reference spatial frequency; according to Ref. 2, these fluctuations are related to the properties of the receptor mosaic of the retina (alternative explanations have been offered; see Ref. 5).

- Discrimination at higher reference spatial frequencies requires higher resolution than receptor mosaic provides.

Variability

Error bars show ± 1 standard error.

Repeatability/Comparison with Other Studies

Similar results were obtained by Refs. 3, 5, 6. Reference 1 failed to find the regular fluctuation of difference thresholds evident here, but in that study reference frequencies were spaced logarithmically and were insufficiently dense to make such an observation likely.

Constraints

- Fluctuations in difference thresholds with reference spatial frequency are even more pronounced for gratings with lower (near-threshold) contrast (Ref. 3).

Key References

1. Campbell, F. W., Nachmias, J., & Jukes, J. (1970). Spatial-frequency discrimination in human vision. *Journal of the Optical Society of America*, 60, 555-559.

*2. Hirsch, J., & Hylton, R. (1982). Limits of spatial-frequency discrimination as evidence of neural interpolation. *Journal of the Optical Society of America*, 72, 1367-1374.

3. Richter, E. R., & Yager, D. (1984). Spatial frequency difference thresholds for central and peripheral viewing. *Journal of the Optical Society of America A*, 1, 1136-1139.

4. Thomas, J. (1983). Underlying psychometric function for detecting gratings and identifying spatial frequency. *Journal of the Optical Society of America*, 79, 751-758.

5. Wilson, H. R. & Gelb, D. J. (1984). Modified line-element theory for spatial-frequency and width discrimination. *Journal of the Optical Society of America A*, 1, 124-131.

6. Woodward, M., Ettinger, E. R., & Yager, D. (1985). The spatial frequency discrimination function at low contrasts. *Spatial Vision*, 1, 13-17.

Cross References

1.609 Visual acuity: difference thresholds for spatial separation;

1.649 Spatial frequency (size) discrimination: effect of contrast;

1.650 Spatial frequency (size) masking;

1.651 Spatial frequency (size) adaptation;

Handbook of perception and human performance, Ch. 7, Sect. 3.1

1.649 Spatial Frequency (Size) Discrimination: Effect of Contrast

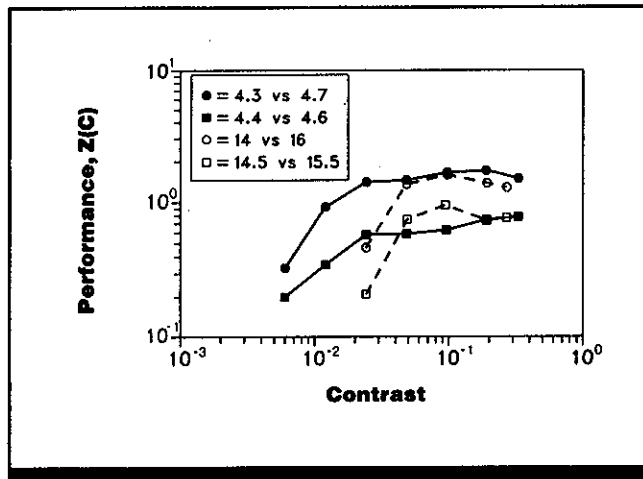

Figure 1. Spatial-frequency discrimination for sine-wave gratings as a function of grating contrast. Ordinate shows the standard normal deviate corresponding to percent correct in identifying which of two slightly different spatial frequencies was presented. Key in figure shows the spatial frequencies of the two gratings to be discriminated in cycles per degree of visual angle (where one cycle = twice the bar width). (From *Handbook of perception and human performance*, based on data from Ref. 2)

Key Terms

Contrast; pattern perception; size discrimination; spatial frequency difference threshold; spatial frequency discrimination

General Description

As the contrast of **sine-wave gratings** (bar patterns) increases from threshold, the ability to distinguish small differences in the **spatial frequency** (bar width) of two otherwise identical gratings increases and then is maintained at a level that depends on the difficulty of the identification task.

Methods

Test Conditions

- 3-deg diameter patch of vertical sine-wave grating centered in 35-deg square with a surround of same luminance (60 cd/m^2) as average luminance of grating
- Gratings varied independently in spatial frequency and contrast

- Grating spatial frequency pairs presented for discrimination are shown in legend to Fig. 1
- Grating contrast increased for 250 msec to desired level, remained constant for 500 msec, and then decreased to zero contrast within the 1-sec observation interval

- In a single session, each of the two spatial frequencies presented at four contrast levels

Experimental Procedure

- Method of constant stimuli; two-alternative forced-choice paradigm; blocked design, with one set of two spatial frequency alternatives per session

- Independent variable: contrast, spatial frequency pair
- Dependent variable: **standard normal deviate** corresponding to percentage of correct judgments
- Observer's task: identify the grating presented on each trial as the higher or lower (in spatial frequency) of the two alternative gratings for that session
- 1 experienced observer

Experimental Results

- As grating contrast increases, ability to identify which of the two gratings was of slightly different spatial frequency increases and then levels off.
- The spatial frequency pairs centered about 15 cycles/deg require more contrast to be discriminated than those centered about 4.5 cycles/deg; this reflects differences in con-

trast sensitivity to high and low spatial frequencies (CRef. 1.624).

- The more closely spaced the spatial frequencies, the more difficult the discrimination task.

Variability

No information on variability was given. Similar results were found with other experienced observers.

Constraints

- Results are likely to be different for spatial frequencies higher than those used here, due to decreased contrast sensitivity at the higher spatial frequencies; this would be expected to cause a rightward shift of the per-

formance curves for spatial frequencies above those employed here.

- Many factors (such as orientation and visual field location) affect contrast sensitivity for spatial patterns and must be considered in applying these results under different viewing conditions (CRef. 1.628).

Key References

1. Hirsch, J., & Hylton, R. (1982). Limits of spatial-frequency discrimination as evidence of neural interpolation. *Journal of the Optical Society of America*, 72, 1367-1374.

*2. Thomas, J. P. (1983). Underlying psychometric function for detecting gratings and identifying spatial frequency. *Journal of the Optical Society of America*, 79, 751-758.

3. Thomas, J. P., Gille, J., & Barker, R. A. (1982). Simultaneous visual detection and identification: Theory and data. *Journal of the Optical Society of America*, 72, 1642-1651.

Cross References

1.609 Visual acuity: difference thresholds for spatial separation;
1.624 Factors affecting detection of spatial targets;

1.628 Factors affecting contrast sensitivity for spatial patterns;
1.648 Spatial frequency (size) discrimination;

1.650 Spatial frequency (size) masking;
1.651 Spatial frequency (size) adaptation;

Handbook of perception and human performance, Ch. 7, Sect. 2.1.

1.650 Spatial Frequency (Size) Masking

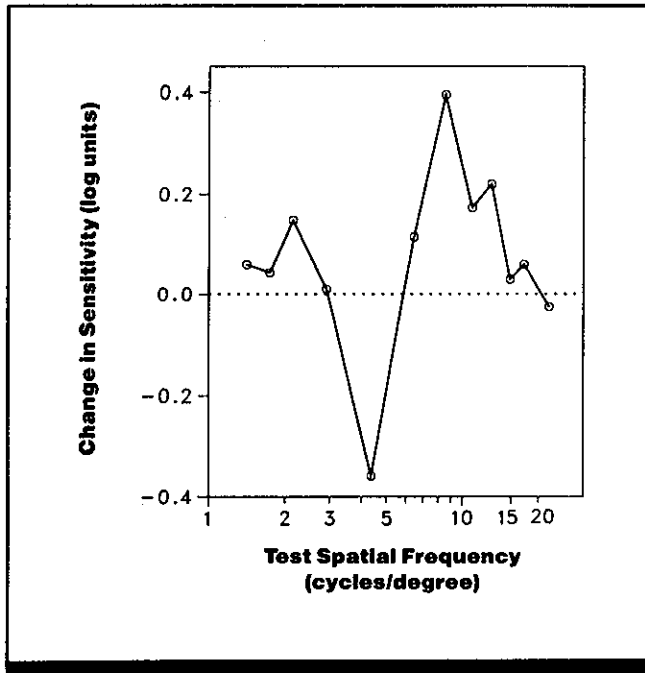

Figure 1. Effect of masking on contrast sensitivity as a function of the spatial frequency of the test grating. The figure shows the amount by which the contrast sensitivity for a test grating was raised (contrast threshold was decreased) when the grating was presented simultaneously with a masking grating of 4.25 cycles/deg and contrast of 0.026. Test grating contrast thresholds ranged between 0.0015 and 0.01. (From Ref. 7)

Key Terms

Contrast sensitivity; pattern detection; size; spatial filtering; visual facilitation; visual masking

General Description

When a **masking** bar pattern (**sine-wave grating**) is presented simultaneously with a test grating, minimum pattern contrast necessary to detect the test grating is increased only if the **spatial frequency** (bar-size) of the masking grating is within an octave of the test grating frequency. When the

spatial frequencies of the mask and a test grating are greater than 1-2 octaves apart, the presence of the mask can lower the detection threshold (i.e., increase sensitivity) for the test grating. This effect is asymmetrical and is more pronounced for gratings above the mask frequency than for gratings below it.

Applications

Displays and viewing environments where low-contrast targets must be detected in the presence of other visual stimuli.

Methods

Test Conditions

- Sine-wave gratings were presented on the face of an oscilloscope; viewing distance was 2.28 m, screen subtended 5 x 5 deg of visual angle

- Space-averaged luminance of all displays was 300 cd/m²
- Masking grating was 4.25 cycles/deg; contrast was constant at 0.026
- Trials for all conditions randomly intermixed; generally, each data point based on hundreds of trials

Experimental Procedure

- Modified staircase procedure; two-alternative forced-choice design
- Independent variable: spatial frequency of test grating
- Dependent variable: contrast threshold of test grating, defined as contrast at which grating could be detected on 75% of trials

- Two 1-sec display intervals were separated by a 0.5-sec blank interval. In one interval, masking grating alone was presented; in the other, both mask and test presented
- Observer's task: choose interval in which test grating was presented
- 2 observers

Experimental Results

- The contrast threshold for a test grating is increased (sensitivity is decreased) when the spatial frequency of the test grating is within ~1 octave of the spatial frequency of a masking grating presented simultaneously. Threshold elevation is maximal when the frequency of the test grating and the frequency of the masking grating are identical (Fig. 1).
- Test grating threshold is lowered (sensitivity is increased) when test and masking frequencies differ by 1-2 octaves. The effect is asymmetric, being more pronounced for test frequencies above the masker frequency than for those below (Fig. 1).
- At widely different test and adapting frequencies, the threshold for the test grating is not affected.

Constraints

- Results will be different when the contrast of the mask varies or the spatial frequency of the mask is different from the spatial frequency of the signal (Ref. 3).
- These results are for near-threshold values of contrast; results may be different for high-contrast targets.

Key References

1. DeValois, K. K. (1977). Spatial frequency adaptation can enhance contrast sensitivity. *Vision Research*, *17*, 1057-1065.
2. Hirsch, J., Hylton, R., & Graham, N. (1982). Simultaneous

recognition of two spatial frequency components. *Vision Research*, *22*, 365-375.

3. Legge, G. E., & Foley, J. M. (1980). Contrast masking in human vision. *Journal of the Optical Society of America*, *70*, 1458-1471.

Variability

Standard error was ~0.03 log units.

Repeatability/Comparison with Other Studies

Similar results have been reported elsewhere (Refs. 2, 4, 6), although at least one study (Ref. 3) failed to show an increase in sensitivity one octave away from the masking grating. The effects of masking are similar to the effects of spatial **adaptation** (prolonged exposure to an adapting grating prior to viewing a test grating); the presence of the adapting grating decreases contrast sensitivity for the test grating when test and adapting gratings are less than ~1 octave apart in spatial frequency but increases sensitivity when test and adapting spatial frequencies are separated by 1-2 octaves (Ref. 1; CRef. 1.651).

- Many factors (such as luminance level, orientation, and visual field location) affect contrast sensitivity for spatial patterns and must be considered in applying these results under different viewing conditions (CRef. 1.628)

4. Nachmias, J., & Weber, A. (1975). Discrimination of simple and complex gratings. *Vision Research*, *15*, 217-224.

5. Olzak, L. (1986). Widely separated spatial frequencies: Mechanism interactions. *Vision Research*, *26*, 1143-1154.

6. Strohmeier, C. F., & Klein, S. (1974). Spatial frequency channels in human vision as asymmetric (edge) mechanisms. *Vision Research*, *14*, 1409-1420.

- *7. Tolhurst, D. J., & Barfield, L. P. (1978). Interactions between spatial frequency channels. *Vision Research*, *18*, 951-958.

Cross References

- 1.628 Factors affecting contrast sensitivity for spatial patterns;
- 1.648 Spatial frequency (size) discrimination;

1.649 Spatial frequency (size) discrimination: effect of contrast;

1.651 Spatial frequency (size) adaptation;

1.652 Orientation-selective effects on contrast sensitivity

1.651 Spatial Frequency (Size) Adaptation

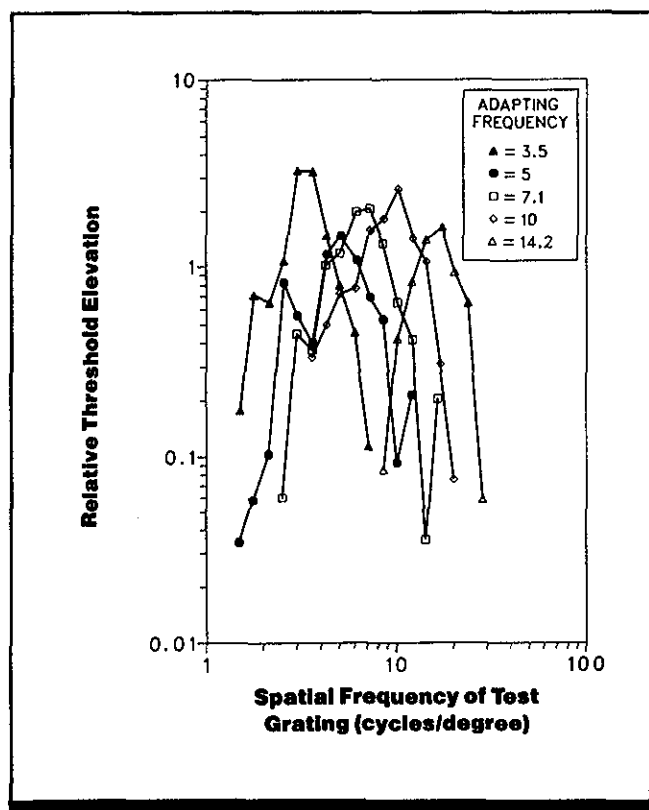

Figure 1. Effect of adaptation on contrast threshold as a function of the spatial frequency of the adapting and test gratings. Ordinate gives the ratio of the contrast threshold for the test grating after exposure to the adapting grating to contrast threshold before exposure; a constant of 1.0 has been subtracted for convenience, so that no difference in "before" and "after" thresholds is indicated by a zero threshold elevation. (From Ref. 1)

Key Terms

Contrast sensitivity; pattern detection; selective adaptation; spatial filtering; spatial interactions

General Description

Contrast sensitivity for a bar pattern (sine-wave grating) may be affected by prior adaptation (prolonged exposure) to a similar bar pattern. Contrast threshold for detection

shows a five-fold elevation for test gratings whose spatial frequency (bar size) is close to that of the adapting grating. Threshold elevation decreases with increasing difference in test grating and adapting grating spatial frequencies.

Applications

Displays and viewing environments where the visibility of low-contrast targets must be maximized (e.g., vigilance tasks involving prolonged viewing of high-contrast stimuli).

Methods

Test Conditions

- Vertical gratings with sinusoidal luminance profiles of varying frequency displayed on oscilloscope; contrast was adjustable by a potentiometer

- Space-average luminance of gratings was always 100 cd/m²
- Viewing distance 2.9 m, screen diameter subtended 1.5-deg visual angle
- Adapting and test gratings were of the same frequency in each case: 3.5, 5, 7.1, 10, and 14.2 cycles/deg; adapting grating pre-

sented for at least 60 sec before each threshold measurement; contrast of adapting grating 1.5 log units above threshold

Experimental Procedure

- Method of adjustment
- Independent variables: spatial frequency of adapting grating, spatial frequency of test grating

- Dependent variables: contrast threshold (mean contrast at which grating was just visible)
- Test thresholds determined for range of frequencies centered on adapting frequency at 1/4 octave intervals
- Observer's task: adjust contrast so grating was just visible
- 1 practiced observer

Experimental Results

- Adaptation to a grating pattern increases the contrast threshold (reduces contrast sensitivity) for test gratings presented subsequently when the spatial frequencies of the test and adapting patterns are close.
- Threshold elevation is greatest (an approximately five-fold increase) when the spatial frequency of the test grating is the same as the spatial frequency of the adapting grating.
- Threshold elevation declines to half the maximum value when test frequency differs from adapting frequency by 1/2 octave.

Constraints

- Adaptation used as a measure of channel bandwidth generally yields wider estimates of bandwidth than some other techniques.
- These results are for near-threshold values of contrast; results may be different for high-contrast targets.

Key References

*1. Blakemore, C., & Campbell, F. W. (1969). On the existence of neurones in the human visual system selectively sensitive to the orientation and size of retinal images. *Journal of Physiology*, 203, 237-260.

2. Blakemore, C., & Nachmias, J. (1971). The orientation specificity of two visual after-effects. *Journal of Physiology*, 213, 157-174.

3. DeValois, K. K. (1977). Spatial frequency adaptation can enhance contrast sensitivity. *Vision Research*, 17, 1057-1065.

Variability

No information on variability was given.

Repeatability/Comparison with Other Studies

Similar findings have been repeated elsewhere for grating patterns (Refs. 2, 3, 4) and for circular targets (CRef. 1.626). Selective adaptation has also been found for bar orientation (CRef. 1.652).

- Many factors (such as luminance level, orientation, and visual field location) affect contrast sensitivity for spatial patterns and must be considered in applying these results under different viewing conditions (CRef. 1.628).

Cross References

1.626 Target detection: effect of prior exposure (adaptation) to a target of the same or different size;

1.628 Factors affecting contrast sensitivity for spatial patterns;

1.648 Spatial frequency (size) discrimination;

1.649 Spatial frequency (size) discrimination: effect of contrast;

1.650 Spatial frequency (size) masking;

1.652 Orientation-selective effects on contrast sensitivity;

Handbook of perception and human performance, Ch. 7, Sect. 2.2

1.652 Orientation-Selective Effects on Contrast Sensitivity

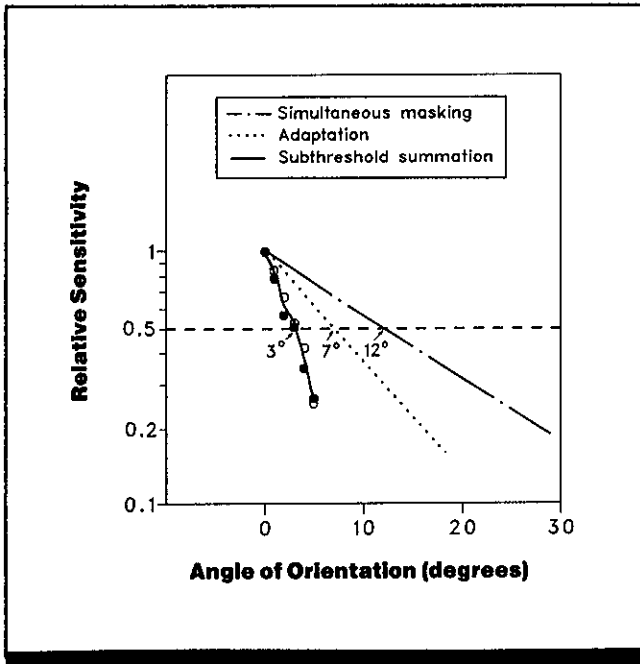

Figure 1. Orientation selectivity for grating patterns derived from three procedures: adaptation (Study 1), simultaneous masking (Study 2), and subthreshold summation (Study 3). For each procedure, the relative effectiveness of one pattern in changing sensitivity to another is measured as a function of the relative tilt of the two patterns. The abscissa shows the angle between the test grating and the adapting, masking, or subthreshold grating presented prior to or simultaneously with the test grating; the ordinate shows the change in sensitivity for the test gratings at a given relative orientation as a proportion of the maximum change in sensitivity produced by the adapting, masking, or subthreshold grating. Estimates of half-amplitude interactive bandwidths (relative orientation at which relative sensitivity is decreased by 0.5) using the three methods are 3, 7, and 12 deg, respectively (as indicated by arrows). Filled and open circles are data for 2 observers in Study 1. (From Ref. 3)

Key Terms

Adaptation; contrast sensitivity; orientation; spatial filtering; spatial orientation selectivity; subthreshold summation; visual masking

General Description

Contrast sensitivity (the reciprocal of **contrast threshold**) for a bar pattern (**sine-wave grating**) is affected by prior or simultaneous presentation of another pattern and by the relative orientations of the two patterns. The presence of one bar pattern can significantly change the contrast sensitivity

for another pattern if their orientations are less than 3-12 deg apart, depending on the measurement technique used (subthreshold summation, **adaptation**, or **masking**). The change in contrast sensitivity is greatest for patterns of identical or nearly identical orientations.

Applications

Displays and viewing environments where the visibility of low-contrast targets must be maximized.

Methods

Test Conditions

Study 1 (Ref. 1)

- Rotatable test and adapting sine-wave gratings, with **spatial frequency** of 8.4 cycles/deg, contrast of 0.7 (where contrast is defined as **Michelson contrast**)
- Initial and successive readaptation periods
- Targets on oscilloscope with fixation point at screen center
- Vertical test grating turned on and off 1.5 times/sec; adapting grating tilted 0-40 deg to the vertical
- Several sec fixation and response time, 30-min recovery time between sessions

tween sessions

- Viewing distance of 290 cm (114 in.)

Study 2 (Ref. 2)

- Vertically oriented test and **masking** sine-wave gratings, both 10 cycles/deg spatial frequency
- Masking grating displayed on one oscilloscope optically superimposed upon test grating on second screen: superimposed gratings contained in circular 2-deg diameter field, average luminance of 40 cd/m², equiluminous 10-deg surround
- Contrast of masking grating ranged from 0.001-1 (where contrast is defined as **Michelson contrast**); orientation of masking

grating ranged from 0, 10, 20, 30, 40, 90 deg from vertical

- 2.8-mm artificial pupil

Study 3 (Ref. 3)

- Sine-wave grating targets displayed on two oscilloscopes: vertical test pattern, 10 cycles/deg; background pattern on second, rotatable scope, 10 cycles/deg, set to one of two unspecified subthreshold contrast levels
- Gratings optically superimposed for display of 2 1/2 deg diameter, average luminance = 4 cd/m²; two small, dark fixation spots at screen center
- Range of orientation of background grating; 0-6 deg from vertical

- **Binocular** vision using natural pupils
- Viewing distance = 114 cm

Experimental Procedure

Study 1

- Method of adjustment under observer's control; adaptation paradigm
- Independent variables: test grating contrast, angle of tilt between test and adapting gratings
- Dependent variable: difference between pre- and postadaptation contrast thresholds for test grating
- Observer's task: adjust contrast of test grating until bar pattern just visible

- 1 observer with extensive practice

Study 2

- Method of adjustment under observer's control; simultaneous masking paradigm
- Independent variables: contrast of masking grating, orientation of masking grating in relation to test grating

- Dependent variable: difference between contrast threshold for test grating alone and test grating with superimposed masking grating
- Observer's task: adjust test grating to threshold
- 1 observer

Study 3

- Method of adjustment under ob-

server's control; subthreshold summation paradigm

- Independent variables: orientation and contrast of subthreshold grating
- Dependent variable: difference between contrast threshold for test pattern alone and contrast threshold for superimposed test and subthres-

hold patterns (where contrast is defined as Michelson contrast)

- Observer's task: adjust the contrast of the test pattern until combined test and subthreshold patterns are judged to be at threshold
- 2 observers, 1 with extensive practice and 1 with no practice

Experimental Results

- Contrast sensitivity for a bar pattern is reduced when the pattern is presented after adaptation to a similar grating. The closer the orientation of the adapting pattern to the test pattern, the greater the reduction in contrast sensitivity.
- Contrast sensitivity for a bar pattern is reduced when the pattern is presented simultaneously with a similar masking grating. The closer the test and masking patterns are in orientation, the greater is the reduction in detectability of the test grating.
- Contrast sensitivity for a bar pattern is increased by superimposing it on a very weak (subthreshold) background pattern of the same orientation; however, this improvement in sensitivity decreases as the orientation difference between the two gratings becomes larger. No increase in contrast sensitivity occurs when the tilt of the background pattern relative to the test pattern is 10 deg.
- The range of relative orientations over which the presence of one grating substantially affects the detectability of

a second grating provides an estimate of the bandwidth (measured as half-width at half amplitude) or orientation tuning (orientation selectivity) in the visual system. Orientation bandwidth estimates derived using the three techniques reported here are 3 deg (subthreshold summation method), 7 deg (adaptation method) and 12 deg (simultaneous masking method). That is, relative sensitivity for a test grating will decrease by half when it is presented after or simultaneously with a second grating whose orientation is within 3-12 deg of the orientation of the test grating.

Variability

Data for both observers tested in Study 1 were very similar. Standard errors of the means for these observers ranged from ~4-24%. No information on variability was given in Studies 1 and 2.

Repeatability/Comparison with Other Studies

Numerous other studies provide evidence for orientation-specific visual phenomena.

Constraints

- Relative orientation selectivity is influenced by the angle of orientation of the test grating (Ref. 2) and by different viewing conditions; it may also be affected by individual differences.
- Differences among the three studies may be due partly to the differing luminance levels employed (Ref. 1).

- These results are for near-threshold values of contrast; results may be different for high-contrast targets.
- Many factors (such as luminance level, orientation, and visual field location) affect contrast sensitivity for spatial patterns and must be considered in applying these results under different viewing conditions (CRef. 1.628).

Key References

*1. Blakemore, C., & Nachmias, J. (1971). The orientation specificity of two visual after-effects. *Journal of Physiology*, 213, 157-174.

*2. Campbell, F. W., & Kulikowski, J. J. (1966). Orientation selectivity of the human visual system. *Journal of Physiology*, 187, 437-445.

*3. Kulikowski, J. J., Abadi, R., & King-Smith, P. E. (1973). Orientational selectivity of grating and line detectors in human vision. *Vision Research*, 13, 1479-1486.

Cross References

1.624 Factors affecting detection of spatial targets;

1.626 Target detection: effect of prior exposure (adaptation) to a target of the same or different size;

1.628 Factors affecting contrast sensitivity for spatial patterns;

1.634 Contrast sensitivity: effect of target orientation;

1.650 Spatial frequency (size) masking;

1.651 Spatial frequency (size) adaptation;

5.805 Illusions of perceived tilt; *Handbook of perception and human performance*, Ch. 7, Sect. 2.2

1.653 Threshold Models of Visual Target Detection

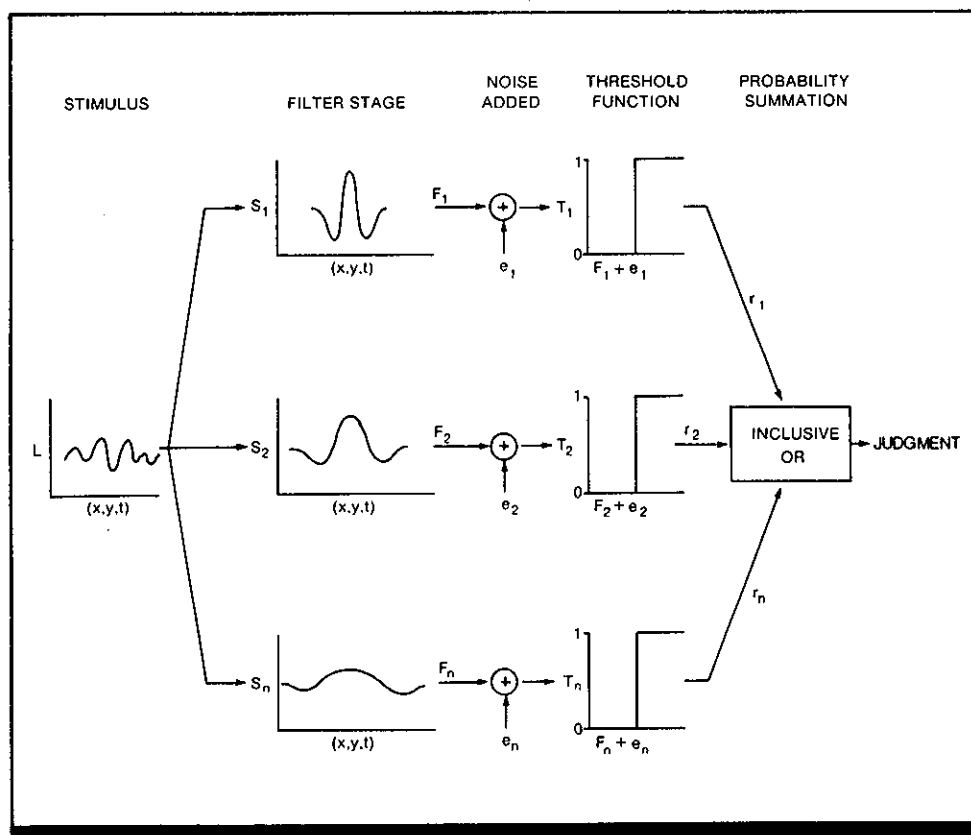

Figure 1. Threshold model of visual detection. The target pattern is represented at the extreme left. It is specified by the luminance function $L(x,y,t)$. It is processed by n pathways that act in parallel. The linear filter is the first stage of processing in each pathway. The expected output of the filter F_i is given by Eq. (1). Independent noise is added, and the sum is passed through the threshold function T_i . The output of the threshold device is r_i , which takes the value 0 or 1. Detection occurs if $r_i = 1$ for one or more pathways. One pathway differs from another only with respect to the sensitivity function of the filter, $S_i(x,y,t)$. This model is a generalized adaptation of a model first introduced in Ref. 8. (From *Handbook of perception and human performance*)

Key Terms

Parallel visual processing; spatial filtering; threshold model of detection; visual detection

General Description

Contemporary models of visual detection assume that perception is mediated by an array of spatially tuned pathways that operate in parallel. Each pathway is spatially tuned in the sense that whether or not that pathway responds to a given visual target depends on the spatial characteristics of the target, including, among others, **spatial frequency**, orientation, and location in the visual field. Models of visual detection specify how each pathway responds to the target and how the responses of the various pathways are combined to arrive at a decision as to whether a target is present.

Threshold models of visual detection assume that visual processing involves four stages, as outlined in Figure 1: (1) linear filtering; (2) addition of noise to the filter output; (3) a threshold function; and (4) response combination. Stages 1-3 occur in parallel within each separate pathway; stage 4 combines responses across pathways to arrive at a detection judgment.

Linear filtering. The response in each pathway is initiated by a linear filter stage. In general, the expected response F_i of a single filter i depends on the spatial and temporal distribution of illumination, or *luminance distribution*, in the visual pattern and the spatial and temporal

sensitivity of the filter. Formally, the luminance distribution is some function $L(x, y, t)$ of spatial co-ordinates x and y and of time t ; the sensitivity of filter i is another function $S_i(x, y, t)$, also of space and time. The response of the filter can therefore be formally represented as the convolution of $L(x, y, t)$ with $S_i(x, y, t)$, as in Equation 1.

$$F_i = \int_{-\infty}^{+\infty} \int_{-\infty}^{+\infty} \int_{-\infty}^{+\infty} L(x, y, t) S_i(x, y, t) dx dy dt. \quad (1)$$

It is sometimes more useful to express the luminance distribution and sensitivity function in terms of spatial and temporal frequencies. For this, the response of the filter is represented as the convolution of the Fourier transforms for the luminance function and the filter sensitivity function. Applications of threshold models have frequently used static **sine-wave gratings** as stimuli, for which the luminance distribution can be described in terms of frequency modulation along a single axis.

Each filter is linear in the sense that (a) its response is directly proportional to the contrast of the visual pattern and (b) its response to a complex stimulus is assumed to be a linear combination of its responses to the separable components of the stimulus.

Noise addition. The output of each linear filter is combined with some source of random variability. The addition of noise is necessary to account for the variability in the observer's responses, for without the added noise, the system would always make the same response to a given target. Most commonly, the added noise is assumed to have a **Gaussian**, or normal, distribution with zero mean and unit variance. The added noise is generally assumed to be independent from one pathway to another.

Threshold Device. The combination of the filter output and the noise is fed into a threshold device, which responds if the combination exceeds some critical value and fails to respond if the combination is below this value. Thus, each filter pathway leads to an all-or-none outcome. The response r_i of pathway i may be specified in formal terms as follows:

$$r_i = T_i(F_i + e_i) \quad (2)$$

where F_i is the expected output of filter stage i , e_i is a random noise component, and T_i is a threshold function which is 1 when $(F_i + e_i)$ exceeds the critical value and 0 otherwise. Because of the added noise, a given pathway may respond to a given target pattern on some trials but not on others. Thus, $P_i(r_i = 1)$, the probability that pathway i will respond to the target, is a basic measure.

Response Combination. The observer is assumed to detect the target on a given presentation if the response in any pathway exceeds threshold (i.e., if $r_i = 1$ in at least one pathway). That is, the responses of the different pathways are combined by probability summation. If the pathways are independent of each other and the noise is added independently to each filter output, then the probability $P(D)$ of detecting the target on a given presentation is simply the probability that activity in at least one pathway has exceeded threshold:

$$P(D) = 1 - \prod_{i=1}^n [1 - P_i(r_i = 1)] \quad (3)$$

Applications and Refinements. A simple application of a threshold model to the detection of a complex grating is cre-

ated by superimposing two single-frequency sine-wave gratings chosen to be sufficiently different in spatial frequency to activate different filters. In this case, the **psychometric function** relating detection of the complex grating to grating contrast can be directly predicted from the psychometric functions relating detection of each simple grating to contrast. Tests of these predictions have been quite successful (Ref. 8) when spatial frequencies differ by a factor of 3 or, for frequencies above 2 cycles/deg, a factor of 2.

In other applications of threshold models, the probability summation equation (Eq. 3) has sometimes been replaced by an approximation introduced by Quick (Ref. 7),

$$P(D) = 1 - 2^{-F^\alpha} \quad (4)$$

where F is a summation of filter outputs as shown in Eq. 5.

$$F = \left[\sum_{i=1}^n F_i^\alpha \right]^{1/\alpha} \quad (5)$$

The value of α can be estimated from the slope of the psychometric function relating detection to stimulus contrast. Empirically, α values of 4 to 5 have been reported. Quick's approximation eliminates the need to compute a cumulative Gaussian to arrive at the probability of activating a threshold device. Instead, detection probability can be related directly to measures of the filter output.

Extensions of the threshold model to other tasks require more detailed specification of the spatially tuned pathways, such as the number of different pathways, how they are distributed, and what their sensitivity functions (filter functions) are. Most extensions of threshold models assume that each pathway responds over only a limited spatial area and that pathways with the same sensitivity (filter) functions are represented in many locations in the visual field. Hence, in addition to summation among filter pathways with different sensitivity functions, probability summation can take place among pathways located in different spatial regions but having the same sensitivity function. This *spatial* probability summation can also be approximated by Equation 4.

Constraints

- Threshold models are designed to account for performance at relatively low levels of contrast; additional mechanisms will be needed to provide a full account of performance under conditions of higher contrast.

Key References

1. Blackwell, H. R. (1963). Neural theories of simple visual discrimination. *Journal of the Optical Society of America*, 53, 129-160.
2. Graham, N. (1977). Visual detection of aperiodic spatial stimuli by probability summation among narrowband channels. *Vision Research*, 17, 637-652.
3. Henning, G. B., Hertz, B. G., & Hinton, J. L. (1981). Effects of

different hypothetical detection mechanisms on the shape of spatial-frequency filters inferred from masking experiments: I. Noise masks. *Journal of the Optical Society of America*, 71, 574-581.

4. King-Smith, P. E., & Kulikowski, J. J. (1981). The detection and recognition of two lines. *Vision Research*, 21, 235-250.

5. Kulikowski, J. J., Abadi, R., & King-Smith, P. E. (1973). Orientational selectivity of grating and

line detectors in human vision. *Vision Research*, 13, 1479-1486.

6. Legge, G. E., & Foley, J. M. (1980). Contrast masking in human vision. *Journal of the Optical Society of America*, 70, 1458-1471.

7. Quick, R. G. (1974). A vector-magnitude model of contrast detection. *Kybernetik*, 16, 65-67.

8. Sachs, M. B., Nachmias, J., & Robson, J. G. (1971). Spatial-frequency channels in human vision.

Journal of the Optical Society of America, 61, 1176-1186.

9. Wilson, H. R., & Bergen, J. R. (1979). A four mechanism model for threshold spatial vision. *Vision Research*, 19, 19-32.

10. Wilson, H. R., & Gelb, D. J. (1984). Modified line-element theory for spatial-frequency and width discrimination. *Journal of the Optical Society of America A*, 1, 124-131.

Cross References

- 1.654 Continuous-function models of visual target detection;
- 1.655 Vector models of visual identification;

Handbook of perception and human performance, Ch. 7, Sect. 2.3.

1.654 Continuous-Function Models of Visual Target Detection

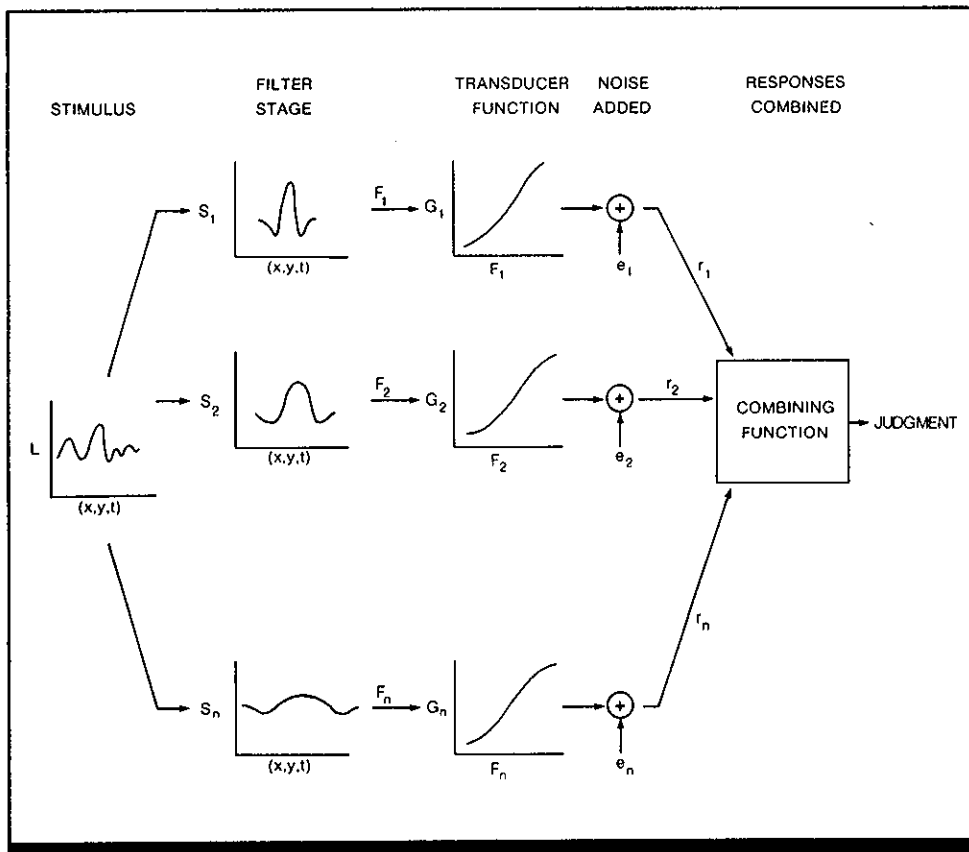

Figure 1. Continuous model of visual detection. The target pattern is represented at far left and is specified by the luminance function $L(x, y, t)$. The target is processed by n pathways acting in parallel. The linear filter is the first stage of processing in each pathway. The output of the filter F_i is transformed by the response function G_i . Independent noise e_i is added to yield the response of the pathway r_i . The responses are combined by a combining function, such as the one given in Eq. (1). The model illustrated is adapted from Ref. 2. (From *Handbook of perception and human performance*)

Key Terms

Continuous model of detection; parallel processing; spatial filtering; visual detection

General Description

Contemporary models of visual detection assume that perception is mediated by an array of spatially tuned pathways that operate in parallel. Each pathway is spatially tuned in the sense that whether or not that pathway responds to a given visual target depends on the spatial characteristics of the target, including, among others, **spatial frequency**, orientation, and location in the visual field. Models of visual detection specify how each pathway responds to the target and how the responses of the various pathways are combined to arrive at a decision as to whether a target is present.

Continuous models of visual detection assume that visual processing involves four stages, (1) linear filtering, (2) transformation of the filter output by a response (transducer) function, (3) addition of noise, (4) response combination. Stages 1-3 take place in parallel within each separate pathway; stage 4 combines responses across pathways to arrive at a detection judgment. Figure 1 shows a generalized example of a continuous model of detection.

Linear filtering. The response in each pathway is initiated by a linear filter stage. In general, the expected response F_i of a single filter i depends on the spatial and temporal distribution of illumination, or *luminance distribution*, in the visual pattern and the spatial coordinates x and y and of time t ; the sensitivity of filter i is another function $S_i(x, y, t)$, also of space and time. The response of the

filter can therefore be formally represented as the convolution of $L(x, y, t)$ with $S_i(x, y, t)$, as in Eq. 1:

$$F_i = \int_{-\infty}^{+\infty} \int_{-\infty}^{+\infty} \int_{-\infty}^{+\infty} L(x, y, t) S_i(x, y, t) dx dy dt \quad (1)$$

It is sometimes more useful to express the luminance distribution and sensitivity functions in terms of spatial and temporal frequencies. For this, the response of the filter is represented as the convolution of the Fourier transforms for the luminance function and the filter sensitivity function.

Each filter is linear in the sense that its response to a complex stimulus is assumed to be a linear combination of its responses to the separable components of the stimulus.

Nonlinear transduction and noise addition. The output of the filter stage is transformed by the continuous response function (transducer function) G_i and then noise is added. A variety of nonlinear transformations have been proposed for function G_i . A considerable amount of data is consistent with a response function that is positively accelerated at low levels of target contrast. Reference 2 has proposed a response (transducer) function that is positively accelerated at low levels of contrast and negatively accelerated at high levels; the variance of the added noise, e_i , is assumed to be constant across pathways and to be independent of contrast. An alternative suggestion (Ref. 7) is that the response function is negatively accelerated at all contrasts but the variance

of the added noise increases at higher levels of contrast.

In formal terms, the response r_i of pathway i is

$$r_i = G_i(F_i) + e_i$$

where G_i is the response function, F_i is the filter function, and e_i is the random noise component.

Response combination. A number of different rules for combining the responses of the different pathways have been proposed. A generalized combination rule is

$$r = \left[\sum_{i=1}^n (a_i r_i)^p \right]^{1/p}$$

where r is the combined response across n pathways and r_i is the response in pathway i . a_i is a weighting factor which weights each pathway according to its expected usefulness, and is determined a priori. The exponent p weights each response according to its magnitude on the particular presentation. More weight is given to the largest responses as p increases. If a_i is constant and p is indefinitely large, the equation corresponds to the rule that all pathways are monitored and the response is governed by the largest response on any pathway. If a_i is 1 for some pathways and 0 for others, then only a subset of pathways is monitored. If $p = 1$ and $a_i = R_i / \sigma_i^2$, where R_i is the expected response of each pathway, and σ_i^2 is the variance of the added noise, then the

equation becomes equivalent to the multiplication of likelihood ratios. This is an optimal combination rule according to **signal detection theory**.

Another alternative response combination rule is the magnitude summation rule proposed in Ref. 5:

$$R = \left[\sum_{i=1}^n R_i^p \right]^{1/p} \quad (2)$$

where R is the combined response and R_i is the expected response of pathway i . With appropriate restrictions on R_i and P , the rule mimics **probability summation** (CRef. 1.653).

Decision rules. Continuous models must also specify the relation between the combined response and detection performance. Various decision rules can be proposed to relate the results of combining the outputs of the filter pathways to the observer's judgment of target presence or absence. For example, consider a two-interval forced-choice detection task in which the observer is presented with two timed intervals, during only one of which a target is presented, and must specify which interval contained the target. The observer may select the interval which has the largest combined response. Alternatively, the observer may be assumed to compute likelihood ratios and to select the interval in which the likelihood of the signal is greater.

Applications

Continuous models of detection have been applied in predicting the effects of contrast masking on thresholds for sine-wave gratings and investigating the relation between the detection and identification of low-contrast patterns, among other things.

As with threshold models of detection, application of continuous models requires specification of the sensitivity functions of the filter pathways and the estimation of these functions is carried out similarly for both types of model.

Comparison with threshold models. Continuous models of detection differ from threshold models in that (1) they replace the threshold function with a continuous response function; (2) they replace probability summation with other

rules for combining the responses of the different pathways; and (3) they specify the addition of noise after the nonlinear transduction stage rather than after the filter stage. Continuous models of detection have been successfully applied to the same range of observations as have threshold models. Although it appears that continuous models require specification of more components (such as a transducer function and a decision rule) than do threshold models, this impression is somewhat misleading, because these components are actually specified implicitly in threshold models. The major advantage of continuous models of detection, however, is that they are special cases of more general models and can be readily extended from detection to identification and discrimination.

Constraints

- Extensions of continuous models to complex visual fields, such as are encountered in real-life situations, may be computationally demanding.

Key References

1. Henning, G. B., Hertz, B. G., & Hinton, J. L. (1981). Effects of different hypothetical detection mechanisms on the shape of spatial-frequency filters inferred from masking experiments. I. Noise masks. *Journal of the Optical Society of America*, 71, 574-581.
- *2. Legge, G. E., & Foley, J. M. (1980). Contrast masking in human

vision. *Journal of the Optical Society of America*, 70, 1458-1471.

- *3. Nachmias, J., & Kocher, E. C. (1970). Visual detection and discrimination of luminance increments. *Journal of the Optical Society of America*, 60, 382-389.
- *4. Nachmias, J., & Sansbury, R. V. (1974). Grating contrast: Discrimination may be better than detection. *Vision Research*, 14, 1039-1042.

5. Quick, R. F., Jr. (1974). A vector-magnitude model of contrast detection. *Kybernetik*, 16, 65-67.

6. Stromeyer, C. F., III, & Klein, S. (1974). Spatial frequency channels in human vision as asymmetric (edge) mechanisms. *Vision Research*, 14, 1409-1420.

*7. Thomas, J. P. (1983). Underlying psychometric function for de-

tecting gratings and identifying spatial frequency. *Journal of the Optical Society of America*, 73, 751-758.

8. Wilson, H. R., McFarlane, D. K., & Phillips, G. C. (1983). Spatial frequency tuning of orientation selective units estimated by oblique masking. *Vision Research*, 23, 873-882.

Cross References

- 1.653 Threshold models of visual target detection;
- 1.655 Vector models of visual identification;

7.420 Signal detection theory; *Handbook of perception and human performance*, Ch. 7, Sect. 2.3

1.655 Vector Models of Visual Identification

Key Terms

Discrimination; identification; labeled channel; vector model of identification

General Description

Vector models of visual identification are designed to predict how well observers can discriminate between two visual patterns. Vector models assume, in common with detection models (CRefs. 1.653, 1.654) that the initial stage of visual processing is accomplished by an array of linear filters acting in parallel. The output of each filter varies as a function of specific target characteristics such as **spatial frequency**, orientation, visual field location, and others. Variability is introduced into the output of each filter from moment to moment by the addition of a **random noise** component. (CRefs. 1.653, 1.654 for a fuller discussion.) In vector models, the response of a single filter is represented by an axis in a multi-dimensional space, and the response of the visual system to the presentation of a given pattern is represented as a point in this space. Repeated presentations of the pattern will define a set of points clustered about the expected response. Presentations of different patterns will define different sets of points.

Figure 1 depicts a slice of the multi-dimensional space after presentation of pattern *a*, pattern *b*, and a noise field containing no pattern but of the same average luminance as *a* and *b*. *A*, *B*, and *N* represent the expected responses to the three patterns. The irregular contours enclosing each value reflect the variation in response produced by the noise in the system. The observer's task is to discriminate *a* from *b*, which will be harder the more the regions around *a* and *b* overlap and easier the less they overlap. The detection response to *a* is represented by the length of the vector **NA** and the response to *b* by the vector **NB**. Discrimination between *a* and *b* is represented by the difference vector **AB**.

It is assumed that the observer divides the space into two regions, one on either side of a decision plane, represented in the figure by a broken line. Any target pattern producing a point on one side of the decision plane is classified as pattern *a* and any stimulus producing a point on the other side of the plane is classified as pattern *b*. Thus, the amount of confusion between *a* and *b* will depend on the distance between the expected responses to the two patterns, that is, the length of the difference vector **AB**, and on the amount of variance around each expected response. The length of the

difference vector depends on the lengths of **NA** and **NB** and on the angle, ϕ , between the two. For quantitative predictions, one vector model (Refs. 4-6) assumes a bivariate normal distribution, with standard deviation σ_v , for the effects of noise. Also, the decision plane is assumed to run perpendicular to the difference vector **AB**.

Formally, this model predicts discrimination performance using the following equation:

$$Z(C) = \sin^{-1}(\phi/2) V/\sigma_v \quad (1)$$

where $Z(C)$ is discrimination performance expressed as a z-score (score expressed as standard deviations units from the mean) and V is the expected lengths of **NA** and **NB**. Thus, the parameter ϕ and the ratio V/σ_v must be estimated to predict discrimination.

Estimates of ϕ are found from experiments using a 2x2 forced-choice procedure, where on each trial an observer is presented with two intervals, one containing a stimulus and one containing a blank field. The observer must first make a *detection* response, selecting the interval containing the stimulus, then make an *identification* response, identifying the stimulus presented. The value of θ can be determined from the ratio of correct identifications to correct detections, when both are expressed as z-scores, according to the relation

$$\sin(\phi/2) = \theta/(1 + \theta^2)^{1/2}$$

where $\theta = z(\text{identify})/z(\text{detect})$. Figure 2 shows estimates of ϕ obtained in this way for patterns differing in orientation (left panel) and for patterns differing in spatial frequency (right panel).

The ratio V/σ_v depends on target contrast and can be estimated for a given level of contrast from a task-dependent scaling of detection, identification, or discrimination performance, expressed in z-score form. The model assumes that a single psychometric function relating V/σ_v to contrast underlies all three tasks, and constructing this function provides an alternative means of estimating the ratio for any contrast level. Figure 3 shows the estimates of V/σ_v and the underlying psychometric function for one observer presented with **sine-wave grating** targets.

Constraints

- Tests of vector models have been limited to tasks with equally discriminable stimuli presented in **foveal** vision.
- Parameter estimation is limited to conditions in which detection and identification are similarly affected by contrast.

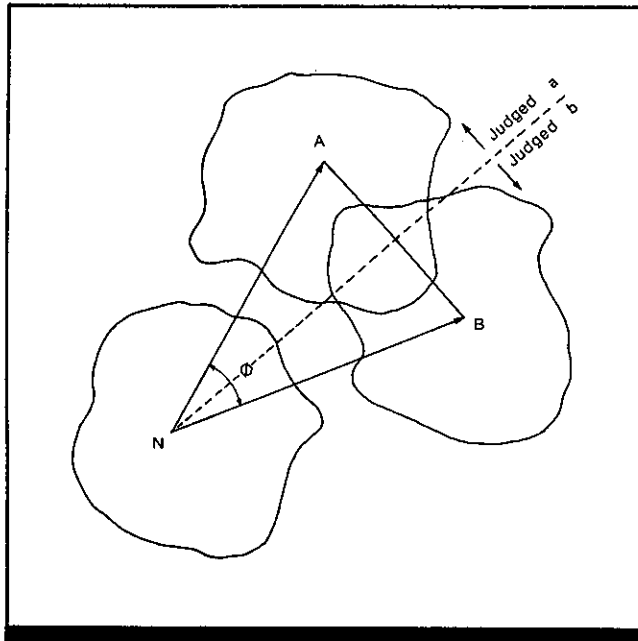

Figure 1. Vector model applied to identification of two patterns, *a* and *b*. The response of the visual system to each presentation of a pattern is represented by a point in a multidimensional space. Each dimension of the space represents the response of one filter pathway. Because of noise, the response to a given pattern varies from one presentation to another. Thus over many actual and/or potential presentations, the pattern is represented by a distribution of points centered on the expected response. The irregular enclosures symbolize these distributions, and *A*, *B* and *N* represent the expected responses to the patterns *a*, *b*, and to a uniform field, respectively. The model proposes that the observer establishes a decision plane. The broken line represents the intersection of this plane with the plane containing *A*, *B*, and *N*. All responses which lie to the left of the plane are judged by the observer to represent pattern *a*, all responses to the right to represent pattern *b*. The probability that the judgment will be correct depends on how much the distributions centered on *A* and *B* overlap. That is, performance is directly related to the length of the difference vector *AB* and inversely related to the dispersion of the distributions. The length of the difference vector, in turn, depends on the lengths of the vectors *NA* and *NB* on the angle ϕ which the vectors form. (From *Handbook of perception and human performance*)

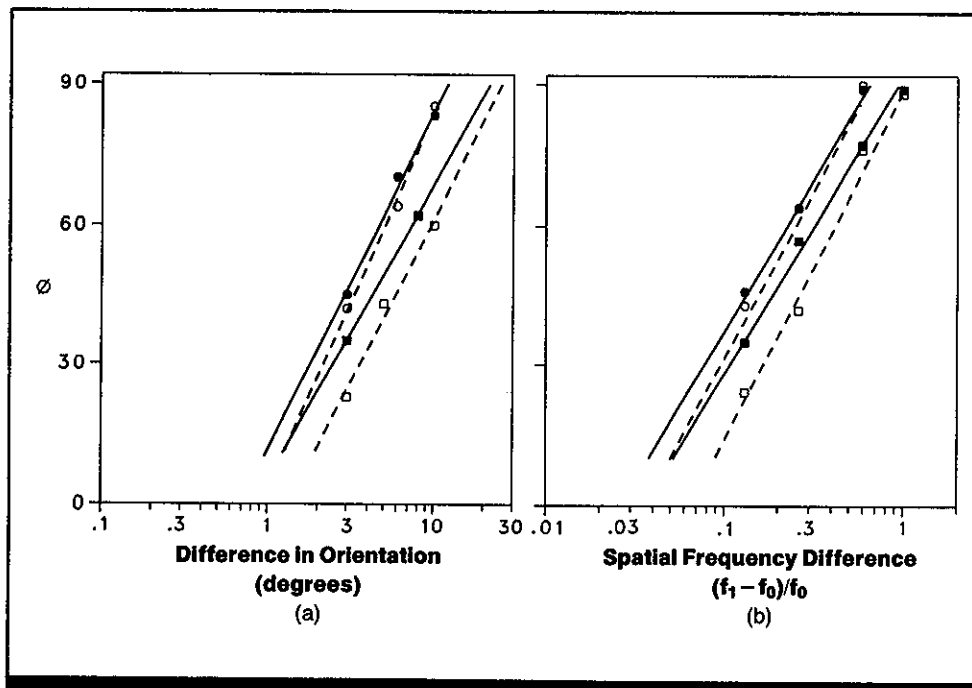

Figure 2. Value of ϕ , the angle formed by the vectors, as a function of differences in orientation and spatial frequency. The target was a circular patch of a sine-wave grating, 3 deg in diameter, viewed foveally with both eyes. The mean luminance was 60 cd/m². The left panel shows ϕ as a function of the difference in orientation to be discriminated. Note that difference in orientation is plotted in logarithmic coordinates. The data are for four practiced observers. The right panel shows ϕ as a function of the difference in spatial frequency to be discriminated. Note that the difference in frequency is defined as a Weber fraction $(f_1 - f_0)/f_0$, where f_0 is the lower frequency and f_1 is the higher frequency. This fraction is plotted in logarithmic coordinates. The data are for four practiced observers. For these data, the frequencies to be distinguished were centered on 3 cycles/degree. Two observers were also tested with frequencies centered on 15 cycles/degree and gave essentially the same results. However, other results (Ref. 1) indicate that the data for a given observer can oscillate along the horizontal axis as a function of small differences in f_0 . Data reported in Ref. 2 (not shown) indicate that ϕ slightly exceeds 90 deg when the targets are gratings that differ in spatial frequency by a factor of 3 or 4. (From Ref. 6)

Key References

1. Hirsch, J., & Hylton, R. (1982). Limits of spatial frequency discrimination as evidence of neural interpolation. *Journal of the Optical Society of America*, 72, 1326-1374.

2. Olzak, L. (1982). Inhibition: Effect on grating detection and identification. *Investigative Ophthalmology and Visual Science*, 22 (Suppl.), 206.

3. Olzak, L. (1985). Interactions between spatially tuned mechanisms: Converging evidence. *Journal of the Optical Society of America A*, 2, 1551.

*4. Thomas, J. P. (1983). Underlying psychometric function for detecting grating and identifying

spatial frequency. *Journal of the Optical Society of America*, 73, 751-758.

5. Thomas, J. P., & Gille, J. (1979). Bandwidths of orientation channels in human vision. *Journal of the Optical Society of America*, 69, 652-660.

*6. Thomas, J. P., Gille, J., & Barker, R. A. (1982). Simultaneous visual detection and identification: Theory and data. *Journal of the Optical Society of America*, 72, 1642-1651.

7. Wilson, H. R., & Gelb, D. J. (1984). Modified line element theory for spatial-frequency and width discrimination. *Journal of the Optical Society of America A*, 1, 124-131.

Cross References

1.653 Threshold models of visual target detection;

1.654 Continuous-function models of visual target detection;

7.420 Signal detection theory

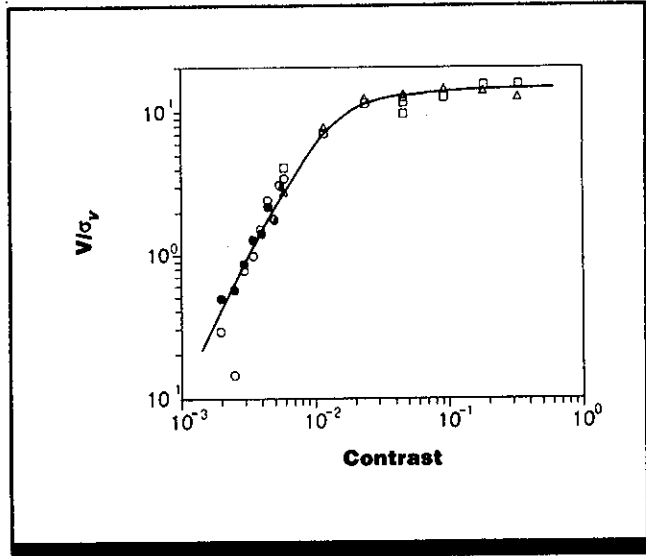

Figure 3. Value of V/σ_v as a function of pattern contrast, with σ_v the standard deviation of the distribution representing the pattern and V the length of the vector representing the expected response to the pattern. The target was a circular patch of a sine-wave grating, viewed foveally with both eyes. The mean luminance was 60 cd/m². The data are for a single practiced observer. The filled data points are derived from a detection task. The open data points are derived from identification tasks in which the observer distinguished between gratings of different spatial frequencies centered on 4.5 cycles/degree. The smooth function fitted to the data has the following form:

$$V/\sigma_v = (Sc)^2 / [1 + \beta (Sc)^2],$$

where c is target contrast, expressed as a proportion; S may be interpreted as contrast sensitivity; and β determines the asymptote of the function. For the data shown, $S = 324$ and $\beta = 0.067$. For a group of four practiced observers, S varied from 230 to 421, with mean of 335, and β varied from 0.045 to 0.141, with a mean of 0.087. Varying the center frequency shifts the function laterally on the log contrast axis and may also affect the initial slope of the function. (From Ref. 4)

Notes

✓

✓

✓

✓

1.656 Psychophysical Methods

Key Terms

Absolute threshold; difference threshold; magnitude estimation; method of adjustment; method of constant stimuli; method of limits; method of paired comparisons; psychophysical method; ranking method; rating scales; signal detection theory; staircase method

General Description

Psychophysics assumes that there are lawful relations between the characteristics of a stimulus and an observer's perceptual response to that stimulus. The psychophysical methods are attempts to measure an observer's sensitivity to some dimension of a stimulus, or to relate a given characteristic of the stimulus to the observer's response. These methods are designed to measure such stimulus and response variables as:

- Absolute threshold: the smallest stimulus energy which the observer can detect
- Difference threshold: the smallest change in a stimulus which an observer can detect
- Equality: the values two stimuli must have to appear equal in some dimension
- Order: the order in which a series of stimuli are ranked with respect to some attribute
- Magnitude: the apparent magnitude of a stimulus or group of stimuli with respect to some physical dimension
- Equality of intervals: the values a series of stimuli must have to appear equally spaced on some scale of attributes
- Equality of ratios: the values a series of stimuli must have to appear in a given ratio to one another on some scale of attributes

One group of psychophysical methods is concerned with the acuteness of our senses and deals with the smallest perceptible stimulus; the other deals with measuring or ordering stimuli covering the entire range of sensation. The choice of a method depends on the type of measurement to be made, the precision required, and whether simultaneous or only successive presentations of the stimuli are possible.

The main methods are the following:

The Method of Adjustment (or Average Error). This method is most frequently used to determine under what conditions two stimuli are judged to be either equal or just noticeably different, but it can also be used to measure absolute threshold, equal intervals, and equal ratios. The observer adjusts a continuously variable comparison stimulus until it satisfies some criterion with respect to a standard stimulus (e.g., equal to it or just different from it). This is done repeatedly. The procedure yields the observer's mean (average) adjustment, its variability (**standard deviation**), and, when the matching point is known, the difference between them. The method seems natural and direct to the observer, and it is usually fast and maintains the observer's interest. But the results are affected by the observer's motor skills and by how carefully he or she makes each adjustment.

The Method of Limits. This method is most frequently used to measure absolute threshold, but it can also be used to measure difference thresholds and equality. The experimenter exposes a stimulus for a given duration, and the observer judges it on some specified dimension (such as intensity) according to a given criterion (e.g., detectable or not). The stimulus is systematically increased in value along the given dimension (starting well below threshold for the expected judgment) and then decreased (starting well above threshold) in small steps of equal physical magnitude. At each step the observer makes a judgment. This is done repeatedly. A standard stimulus can also be presented at the same time, with the observer asked to judge whether the comparison stimulus is, e.g., smaller, equal, or larger. Often only the ascending series is used to prevent **adaptation** to the stimulus. The method yields a mean threshold and its standard deviation. It is relatively fast and more precise than the method of adjustment. But the observer may change his judgment prematurely ("error of expectation") or persist in a judgment over too many trials ("error of habituation"). To avoid these disadvantages, a variant of this method, the staircase method, was developed.

Staircase Method. In this method, stimulus is presented at some intensity. If it is detected, it is decreased in intensity in steps of equal physical magnitude until it is no longer detected. At that point, the intensity is increased in the same steps until it is again detected, then decreased again, and so on. The threshold is the mean of the intensities at all the points of reversal. The method yields a mean threshold and its standard deviation. The method is quite fast and precise. A "double staircase" procedure is sometimes used, in which the experimenter runs two (or more) independent staircase procedures simultaneously, alternating between them randomly.

Method of Constant Stimuli. This method is used primarily to measure absolute and difference thresholds. The method measures changes in stimulus value, along some dimension, that lie in the transition zone between values or changes that can almost always be perceived and those that can almost never be perceived. It thus provides a very sensitive and precise measure of small changes in threshold. The experimenter first determines the observer's range of sensitivity and then selects about five or six stimuli at equally spaced intervals spanning the transition zone. Each stimulus is then presented an equal number of times in random order. A frequency-of-seeing curve or psychometric function (CRef. 1.657) is calculated showing the percentage of trials on which the stimulus or stimulus difference was detected

as a function of stimulus magnitude along the given dimension. The stimulus value at which the stimulus or stimulus difference was detected on 50% of trials is usually taken as the threshold, and the difference between this value and the stimulus value which was perceived 84% and 16% of the time constitutes ± 1 standard deviation.

Signal Detection Analysis. The thresholds measured by the above psychophysical methods vary both with the properties of the stimulus and with the characteristics of the observer. A given threshold is a measure not only of the observer's physiological sensitivity, which is what the experimenter is trying to determine, but also of the observer's criterion for responding, which the experimenter does not wish to be a factor. That is, two observers may be equally sensitive physiologically, but one may be quick to report the presence of the stimulus even in the face of some doubt while the other observer may be more conservative and wait to report its presence until detectability is high.

The theory of signal detection proposes to separate these two factors by analyzing the tendency of an observer to guess. The number of times an observer reports detecting a stimulus when it is in fact presented (hits) and the number of times he or she reports a stimulus when no stimulus was presented (false alarms) are calculated under different conditions that are assumed to elicit differing response criteria on the part of the observer. From this the observer's response biases and actual sensitivity can be inferred (CRef. 7.420).

This method yields estimates of thresholds that are believed to reflect actual neural sensitivity. The method has been applied not only to absolute and difference thresholds but to a wide variety of other psychological measurements.

Method of Paired Comparison. This method is used to rank a series of stimuli. Each stimulus is paired with every other stimulus in random order. The observer need compare only two stimuli at a time and decide which better meets the given criterion. The total proportion of the presentations in which each stimulus was preferred is calculated, which

gives the relative rank of the stimuli. It does not, however, indicate the psychological distance between the stimuli. The method is very time consuming and tedious, particularly with a large number of stimuli. It can be applied to virtually all psychological dimensions, whether or not they represent a physical continuum.

Rating Scale. This method is also used to rank a series of stimuli. Each stimulus is assigned to one of several (typically 5 or 7) categories reflecting different quantities of a given attribute. The method yields the mean or median rating or order of each stimulus. The ratings, unfortunately, are often not stable, and they can be quite arbitrary unless the observer is given a reference point. It has also been difficult to prove that psychologically equal intervals are obtained.

The Ranking Method. This is a third method used to rank a series of stimuli. A set of stimuli, usually all presented at once, are ordered by the observer along a given dimension. This is done many times by one observer or once by many observers. A mean rank and standard deviation are computed for each stimulus. The method is quick and easy, unless the number of stimuli is very large. It yields the order in which the stimuli are preferred, but it is doubtful that the spacing of the stimuli can be determined in this way.

Magnitude Estimation. This method is used to establish the subjective magnitude of a stimulus or a series of stimuli. The experimenter selects one stimulus as a standard. The experimenter may assign it a number or allow the observer to do so. The observer is then presented with the other stimuli one at a time and instructed to assign to each one a number that seems proportional to its subjective magnitude as compared to that of the standard. Typically, the logarithms of the assigned numbers are plotted against the logarithms of the physical magnitudes of the stimuli, and the best-fitting function is computed. The slope of this function gives the increase in psychological magnitude as the physical value is increased.

Key References

*1. Corso, J. F. (1967). *The experimental psychology of sensory behavior*. New York: Holt, Rinehart and Winston.

*2. Egan, J. P., & Clarke, F. R. (1966). Psychophysics and signal detection. In J. B. Sidowski (Ed.), *Experimental methods and instrumentation in psychology* (pp. 211-246). New York: McGraw-Hill.

*3. Engen, T. (1971). Psychophysics: I. Discrimination and detection. II. Scaling methods. In J. W. Kling & L. A. Riggs (Eds.), *Woodworth & Schlosberg's experimental psychology* (pp. 11-86). New York: Holt, Rinehart, and Winston.

Cross References

1.657 Psychometric functions;
7.420 Signal detection theory

1.657 Psychometric Functions

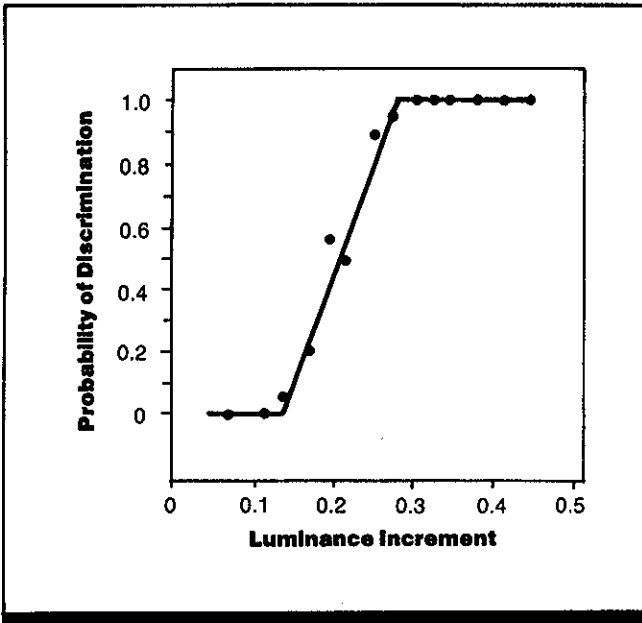

Figure 1. Example of visual detection data described by a linear psychometric function. Observer's task was to detect a luminance increment. Note approximate range of 2:1 between end-points of linear portions of curves. From this data, the luminance increment required to stimulate one neural quantum is about 1.5. (From Ref. 1)

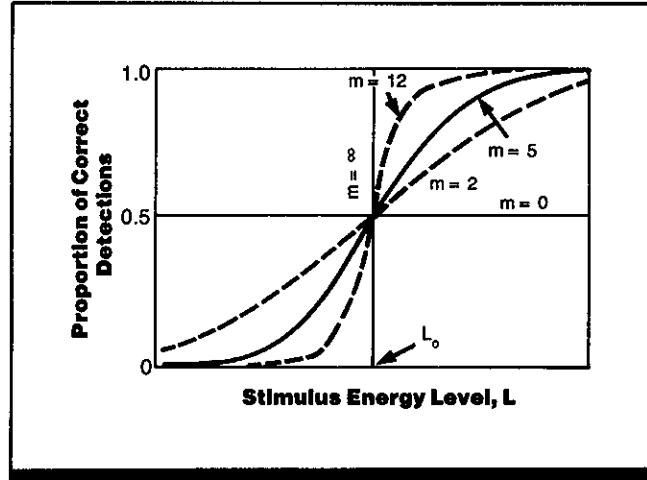

Figure 2. Cumulative normal ogives for various values of the slope parameter m . All curves represent an observer with the same threshold, but with different degrees of variability in momentary sensitivity. The standard deviation of the distribution of momentary sensitivities is $1/m$. (From Ref. 5)

Key Terms

Cumulative normal function; forced-choice procedure; frequency-of-seeing curve; log-normal function; logistic function; neural quantum theory; probit analysis; psychometric function; Quick function; signal detection theory; target detection; yes/no

General Description

Visual performance is usually described in terms of thresholds. A threshold is defined as the target energy (expressed in luminance, intensity, contrast or comparable physical units) at which an observer "just detects" the target. The phrase "just detects" generally refers to a situation where the observer can detect the target, on average, 50% of the times it is presented, although another criterion (e.g., 75%) may be used.

Thresholds are used to measure the effects of changes in (1) target properties (e.g., size, color, duration), (2) viewing conditions (e.g., presence of other targets, target location in the field of view, presentation to one or both eyes), or (3) the observer's state (e.g., pupil size, age, training). Thresholds are the usual **dependent** (response) variable in quantitative descriptions of visual behavior.

Thresholds are measured by presenting targets of different energy levels L several times each and tabulating the proportion of times P the observer detects the target at each level. This results in a set of data points (P, L) that can be

connected to form a curve $P(L)$, known as a *frequency of seeing curve* or, more generally as a *psychometric function*. The psychometric function is roughly S-shaped, and is characterized by threshold L_0 , the value of L for which $P = 0.50$, and by a steepness measure m that is equal to the slope of the curve in the neighborhood of L_0 . Values of L_0 and m can be measured in a crude fashion by visual interpolation from the obtained data points, or derived from the formula of a curve fitted to the data points (Ref. 6). Several alternative formulas have been proposed to describe the psychometric function. Each is based on certain assumptions about the underlying mechanism that causes the observer's sensitivity to fluctuate from trial to trial. Some of the most useful formulas are described below.

Measurement procedures

In measuring a threshold, the observer may be asked either to detect the presence of a target on each trial or to discriminate the location of the target among two or more possible locations or time-intervals. The first method is termed a yes/no procedure. The second method is known as an

n -alternative forced-choice (n AFC) procedure, where n = the number of alternative locations or intervals in which a target may appear. In the yes/no procedure, the proportion of detections decreases to zero as L approaches 0, whereas in the n AFC procedure the proportion of correct detections (discriminations) tends toward $1/n$ as L approaches 0 (because $1/n$ is the proportion of correct detections due to chance). In the yes/no procedure, "blank" targets ($L = 0$) may be randomly intermingled with target presentations to quantify the observer's tendency to guess: the obtained value of $P(0)$ is called the false-alarm rate. In either method, when $P(0) > 0$, the shape of the psychometric function is distorted and curve fitting becomes difficult. To solve this problem, obtained values of P may be corrected using Abbott's formula (Refs. 4, 7):

$$P'(L) = [P(L) - P(0)]/[1 - P(0)],$$

where $P(0)$ is either the false-alarm rate obtained from a yes/no procedure or the proportion of correct discriminations expected by chance ($= 1/n$) in the n AFC procedure. The "corrected" values $P'(L)$ range between 0 and 1.

Alternative formulations of the psychometric function

To determine the appropriate threshold and slope from psychometric data, a continuous curve may be fitted to the obtained data points. Several functions have been proposed as appropriate descriptors of the psychometric function.

Linear function

The simplest form for a psychometric function is the line. Under certain conditions, psychometric data are in fact well described by a straight line (Ref. 2). The theoretical account for this result is known as *neural quantum theory*. According to this theory, a target is detected only if it causes a certain amount (quantum) of neural activity. The lowest intensity target (L_1) that is ever detected is assumed to just stimulate one quantum when the observer's sensitivity is at its maximum. By similar reasoning, a target of $2L_1$ stimulates two neural quanta when the observer's sensitivity is maximal, and stimulates one quantum even when sensitivity is at a minimum. Therefore, a target of $2L_1$ is the lowest intensity level that is always detected. The proportion of detections is assumed to increase linearly between L_1 and $2L_1$, as described by the equation

$$\begin{aligned} P(L) &= (L/L_1 - 1) \text{ for } L_1 < L < 2L_1 \\ &= 0 \text{ for } L < L_1 \\ &= 1 \text{ for } L > 2L_1 \end{aligned} \quad (1)$$

The threshold is the value of L for which $P = 0.5$; that is, $L_0 = 1.5L_1$. The slope of the psychometric function is $1/L_1$.

The neural quantum formulation provides a good fit to psychometric data under conditions in which sources of variability are minimized. These conditions include the use of warning tones prior to each target presentation, a situation free of distractions, and a well-practiced and attentive observer. Data must be obtained within a single session, and trials must be "blocked" so that targets of one intensity level are not intermixed with those of other levels. When the data are well described by the neural quantum formulation, a **least-squares** linear-fit procedure should yield a line satisfying Eq. 1 (Fig. 1).

Cumulative normal function

This function is assumed to characterize most psychometric data. Its use is based on the premise that the observer's threshold at any moment fluctuates as a normally distributed random variable with a mean value of L_0 and a standard deviation of $1/m$. The momentary threshold would have such a distribution if sensitivity were determined by the sum of a large number of influences acting independently. If on any trial the random variable takes on a value L' , then the observer detects all targets with $L > L'$. Therefore the probability of detection P is the cumulative value of the probability distribution of momentary sensitivity. The cumulative normal function, sometimes known as the probit function, has a smooth S shape known as an ogive (Fig. 2). The equation for this function is

$$P(z) = \frac{1}{\sqrt{2\pi}} \int_{-\infty}^z e^{-(z'^2/2)} dz' \quad (2)$$

where $z = m(L - L_0)$. To find the values of L_0 and m for a set of psychometric data, it is necessary to fit a cumulative normal function to the data points. This is done by finding a number z that satisfies Eq. 2 for each obtained proportion P . These z values can be obtained from published tables of the normal function. The psychometric data are now replotted as a set of points (z, L). Alternatively, the points (P, L) may be plotted directly onto special graph paper with a vertical "probability" axis (such as the y -axis in Fig. 3 with percent/100). To the extent that the original data approximate a cumulative normal curve, the points should lie on a straight line. The best-fitting straight line can be found graphically or calculated using a standard least-squares procedure (Ref. 6). The threshold is obtained from the probability paper plot by finding the value of L corresponding to $P = 0.5$, or from the z versus P plot by finding the value of L corresponding to $z = 1$ and subtracting L_0 . The value of Eq. 2 for $z = 1$ is 0.841.

Log-normal function

In this formulation, the observer's momentary threshold is assumed to fluctuate as a normally distributed random variable but with respect to $\log L$ rather than L . This would be the case if the initial visual response to a target level were logarithmic; such a transformation may occur at the photo-receptor level. As a result, the psychometric function is assumed to be a cumulative log-normal function. The procedure for finding L_0 and m is the same as for the cumulative normal function, except that the least-squares calculation is carried out using the set of points ($z, \log P$) rather than (z, P). The threshold is determined by finding the value of $\log L$ corresponding to $z = 0$ and calculating the antilog. Similarly, the reciprocal of the slope is found by finding the value of $\log L$ corresponding to $z = 1$ and subtracting the value of $\log L$ corresponding to $z = 0$. L_0 and m can also be obtained graphically by plotting $\log L$ against P on probability paper. If the assumptions of the log-normal formulation are met, the distribution of points should be approximately linear (Fig. 3). Since the range of L over which the psychometric function changes is relatively small, the shapes of cumulative normal and cumulative log-normal functions do not differ substantially. For practical purposes, normal or log-normal formulations provide similar estimates of L_0 and m .

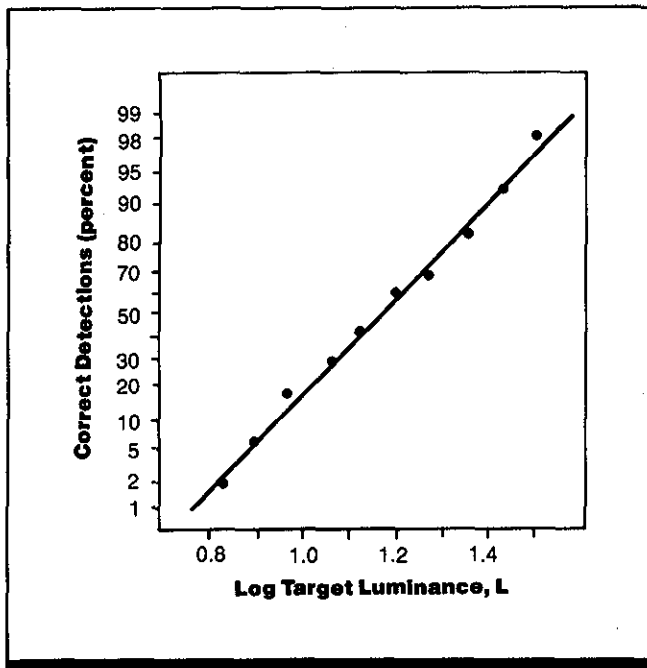

Figure 3. Frequency-of-seeing data fit by a log-normal function. Data are plotted on probability paper (percent = probability times 100) as a function of log target luminance. Threshold and slope are obtained by finding the best fitting straight line through the plotted points. Observer's task was to detect a small flash of light. (From Ref. 3)

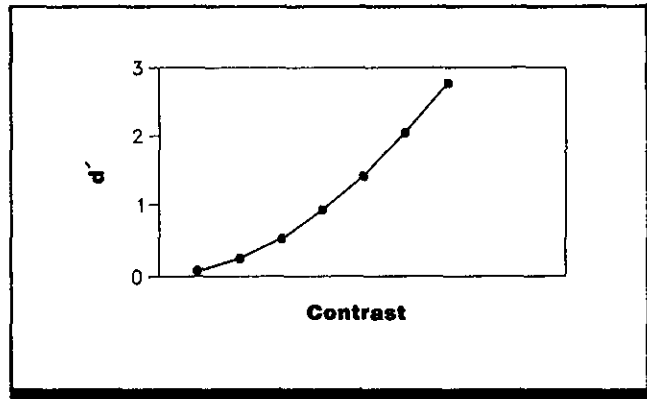

Figure 4. Psychometric function using d' to measure detectability. The horizontal axis is target contrast. Note that d' is an accelerating function of contrast. Plotted on double logarithmic coordinates, the data would fall on a straight line with slope >1 . Each data point is based on a large number of detection trials in which the observer reports "seen" or "not seen" at the end of each trial. (From *Handbook of perception and human performance*)

Logistic function

Because Eq. 2 is mathematically complicated, it is impractical for computational purposes and tables of $F(z)$ must be consulted. A useful simplified formula which approximates the cumulative normal function is the logistic function

$$P(z) = [1 + e^{-z}]^{-1} \tag{3}$$

The procedure for finding the best fitting logistic function is similar to that described above; for each obtained P , the corresponding value of z is found from Eq. 3. The points (z, P) are then fitted by a least-squares calculation, and L_0 is found from the line as the value of L corresponding to $z = 0$. The reciprocal of the slope m is obtained by finding L corresponding to $z = 1$ and subtracting L_0 . If a more accurate approximation to the cumulative normal function is required, the exponent $-z$ in Eq. 3 may be replaced by $-1.81z$.

Quick function

This formula is based on a function first described by Weibull (Ref. 8), who found that it fitted data from various sources more closely than a cumulative normal curve. It was adapted by Quick (Ref. 9) to describe systems in which a target may be detected by a number of independent channels, or detected independently over a number of time intervals (Ref. 10). The equation is

$$P(L) = 1 - 2^{-(L/L_0)^m} \tag{4}$$

where m , as usual, is the slope of the function in the neighborhood of L_0 . In addition, m represents the number of in-

dependent channels involved in detection. The bestfitting version of Eq. 4 may therefore be used to estimate the number of such channels in operation. As usual, threshold is defined as the value of L corresponding to $P = 0.5$.

Signal detection formulation

The theory of signal detectability (CRef. 7.420) is based on the assumption that an observer's internal state is "noisy" (i.e., the magnitude of sensory experience fluctuates), even when no external target is present. When a target is presented, the observer's task is to distinguish the "signal" due to the target from internally generated "noise." According to this formulation, a "yes" response to a blank (false alarm) is not due to guessing or chance, but to the fact that internal noise may be indistinguishable from the sensory experience created by a target. Signal detection theory characterizes sensitivity by a signal-to-noise ratio denoted d' . This parameter is measured by presenting a series of targets of level L randomly intermingled with an equal number of blanks, and tabulating the proportions of hits (correct detections) and false alarms. Sensory magnitude is assumed to vary as a normally distributed random variable, so that d' may be calculated from tables of the cumulative normal distribution by subtracting the value of z corresponding to the false alarm rate $z(FA)$ from the value of z corresponding to the hit rate: $d' = z(H) - z(FA)$. If the assumptions of signal detection theory are true, d' should be proportional to L . Under many conditions, however, d' is an accelerating function of target intensity (Ref. 7; Fig. 4).

The signal detection formulation also provides an estimate of the observer's response bias, which affects the rela-

tive proportion of "yes" and "no" responses made to either targets or blanks. A cautious subject tends to restrict the number of "yes" responses, whereas an observer with a looser criterion of responding tends to respond "yes" relatively more often. The response bias (denoted β) depends on (1) the relative numbers of targets and blanks presented and (2) the value (to the observer) of making a correct de-

tection compared to the cost of being incorrect; however, the response bias (β) is independent of sensitivity (d'). Response bias may be calculated from the ratio $f(z(H))/f(z(FA))$, where f denotes the normal probability density distribution and H and FA denote the obtained proportions of hits and false alarms. For a high (strict) criterion, $\beta > 1$, and for a low (lax) criterion $\beta < 1$.

Key References

1. Blackwell, H. R. (1953). Evaluation of the neural quantum theory in vision. *American Journal of Psychology*, 66, 397-408.
2. Corso, J. (1967). *The experimental psychology of sensory behavior*. New York: Holt, Rinehart, & Winston.
3. Crozier, W. J. (1950). On the visibility of radiation at the human

fovea. *Journal of General Physiology*, 34, 87-136.

4. Finney, D. J. (1962). *Probit analysis* (2nd ed.). Cambridge, England: Cambridge University Press.
5. Guilford, J. P. (1936). *Psychometric methods*. New York: McGraw-Hill.
6. Kling, J. W., & Riggs, L. A. (1971). *Woodworth & Schlosberg's experimental psychology* (3rd Ed).

New York: Holt, Rinehart, & Winston.

7. Lieberman, H. R. (1982). Computation and psychophysical thresholds using the probit technique. *Behavior Research Methods and Instrumentation*, 15, 446-448.
8. Nachmias, J., & Kocher, E. C. (1979). Visual detection and discrimination of luminance increments. *Journal of the Optical Society of America*, 60, 382-389.

9. Quick, R. F. (1974). A vector-magnitude model of contrast detection. *Kybernetik*, 16, 65-67.

10. Watson, A. B. (1979). Probability summation over time. *Vision Research*, 19, 515-522.
11. Weibull, W. A. (1951). A statistical distribution function of wide applicability. *Journal of Applied Mechanics*, 293-297.

Cross References

- 7.420 Signal detection theory;
Handbook of perception and human performance, Ch. 7,
 Sect. 1.2

Notes



Section 1.7 Color Vision

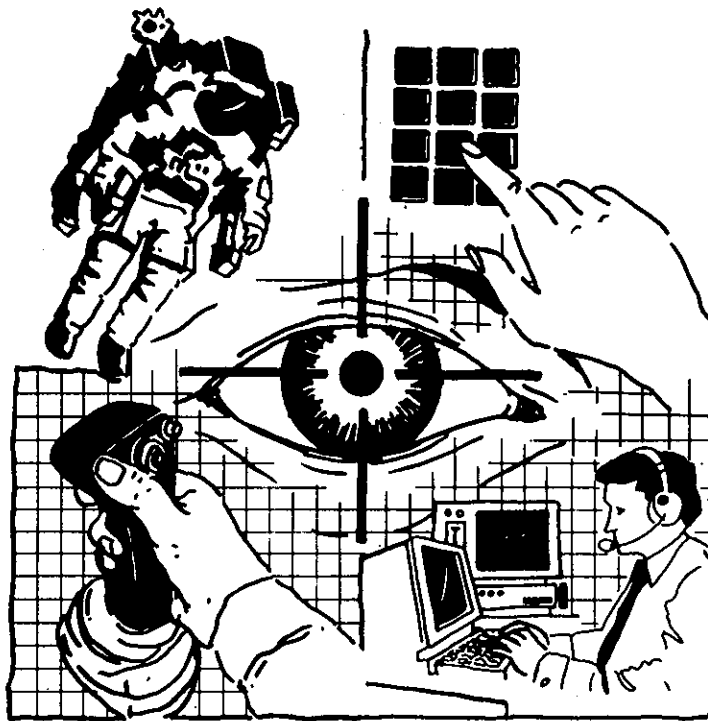

1.701 Targets and Procedures Used to Study Color Perception

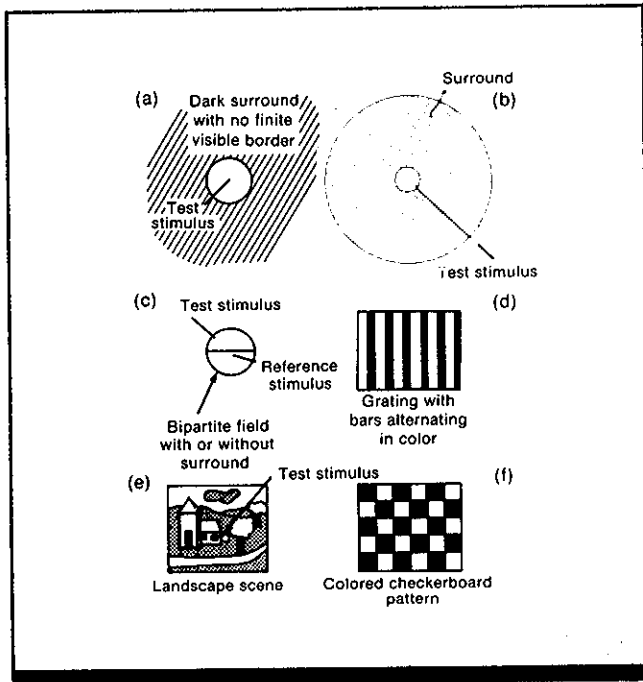

Figure 1. Typical visual field configurations used in studying color vision. Field configurations (b) and (c) are examples of classical laboratory arrangements; (d), (e) and (f) are examples of configurations frequently used in more recent experiments. (From *Handbook of perception and human performance*)

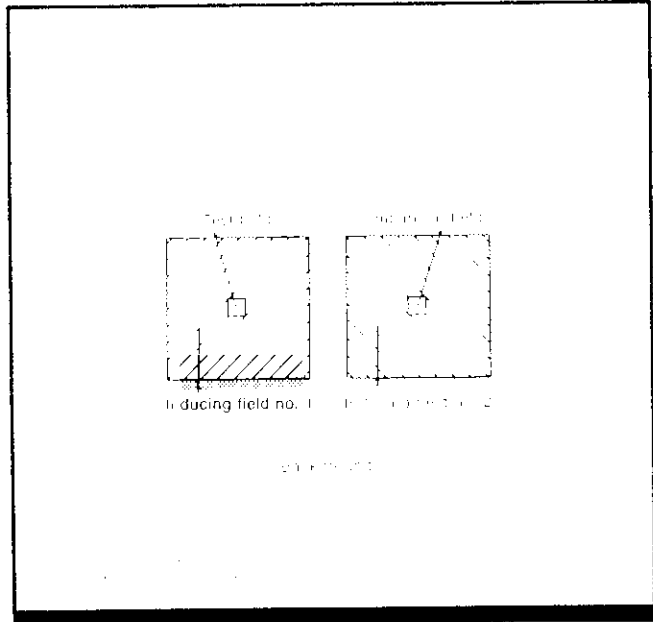

Figure 2. Example of visual field configuration used in chromatic and achromatic induction experiments. This arrangement allows the observer to make lightness matches between the test and comparison field by manipulating the reflectances (or luminances) of the comparison field. Chromatic induction is studied by varying the spectral content of the surround fields. (From *Handbook of perception and human performance*)

Key Terms

Chromatic induction; color appearance; colorimetry; heterochromatic brightness matching; heterochromatic flicker photometry; lightness matching; luminous efficiency; spectral sensitivity

General Description

The appearance of a single, colored target varies considerably depending on the conditions under which it is viewed. The variables known to affect the perception of color include spatial relationships, temporal variations, and changes in levels of illumination of adjacent fields relative to focal areas (CRef. 1.707).

The typical laboratory study of color perception involves either a center-surround arrangement (Fig. 1a,b) or a bipartite field (Fig. 1c), although different researchers have employed a variety of stimulus patterns. Within such paradigms, an observer may be asked to match the lightness or hue of one part of the stimulus (test field) to that of another part (comparison field), to name various hues, or to minimize the contrast between two adjacent patches of color.

Configurations such as Fig. 1a can be used to assess the

luminous efficiency (relative effectiveness in stimulating vision) of various wavelengths of light. A monochromatic light is presented, either continuously or in brief exposures, and the observer notes the minimal radiance required to see the test areas. On the basis of such judgments, one can derive the spectral sensitivity function for the observer.

In heterochromatic flicker photometry (method of minimum flicker), a reference light of a given luminance and spectral content is alternated rapidly with coextensive test light of different spectral composition. At the rapid alternation rates used (typically 10-20 Hz), the observer does not see alternations of hue; however, differences in the brightnesses of the two stimuli are perceived as flicker. The intensity of the test light is adjusted until this flicker is minimized or eliminated. Luminous efficiency functions can be obtained from this procedure.

Direct heterochromatic brightness matching, which is related to minimum flicker, may use a stimulus configuration involving a comparison field such as that in Fig. 1b and a test area that may or may not have its own surround. In heterochromatic brightness matching, an observer is asked to match the brightness levels of two stimuli with different spectral composition; that is, the observer is required to focus on brightness while ignoring hue and to make a match between the test and comparison patches. The luminous efficiency function derived using this technique is similar to that obtained with minimum flicker procedures; therefore, the technique of minimum flicker may be preferred, since with the latter method the observer's task is easier and the results are less variable (see Constraints section).

One common procedure for assessing perceptual variations involves **chromatic induction**. Figure 2 shows a typical stimulus configuration in which an observer views targets that differ either in hue or in lightness. The general results of such studies are fairly consistent:

- Uniformly colored targets take on different hues when viewed in the presence of patches of different colors than they do when viewed in isolation.
- Color fields need not be adjacent to or contiguous with the colored regions they affect, although the induction effect diminishes systematically as the inducing field becomes more remote from the focal area. Likewise, multiple inducing areas exert predictable effects.
- Adjacent white and highly saturated monochromatic areas show greater contrast under conditions of lower retinal illuminance, although **achromaticity** appears to be more important in creating a distinct border between two elements in a bipartite field, such as in Fig. 1c; the distinctness

of a border may be diminished by the presence of a chromatic difference (CRef. 6.313).

- For both red/green and yellow/blue fields, as redness (yellowness) in the inducing area increases, the perceived redness (yellowness) of the focal area decreases.

Color appearance is also studied through lightness matches of test and comparison targets. When an observer attempts to match the luminance of a comparison field with that of a test field (with a circular center-surround arrangement analogous to that in Fig. 2), as the luminance of Inducing Field No. 1 (L_{I1}) increases, the luminance to which the comparison field (L_C) must be adjusted to appear equally light increases slightly; however, with increasing levels of L_{I1} , the value to which L_C must be set to achieve equal lightness with the test field begins to drop so that ultimately, with any increase in L_{I1} , the comparison field cannot be made to appear as "black" as the test field, even at a setting of $L_C = 0$. Only by increasing the luminance of Inducing Field No. 2 (L_{I2}) can the comparison field be "darkened" enough to achieve a satisfactory match to the test field (CRefs. 1.712, 1.713).

Color naming tasks have also been used to investigate the appearance of color. As an example of such an approach, observers might be asked to note whether a particular target contains an element of redness/greenness or yellowness/blueness or whether the target is neutral with respect to a particular color pair. Results across studies vary, depending on (1) whether two patches of color are viewed simultaneously or in sequence, and (2) whether both patches are viewed with the same eye (or with both eyes) or each patch is viewed by a different eye.

Constraints

- There are large individual differences in perceptions of lightness or hue, and in responses in matching tasks.
- Practice may have a significant effect on the observer's ability to identify and label a specified color in a target stimulus. Further, variability in performance may be due to a criterion shift by the observers (their willingness to declare the presence of some specified color in a target patch), rather than by any consistent properties of the visual system itself.

- In heterochromatic brightness matching, the task is quite difficult and results vary considerably, not only across different individuals, but also for the same observer across trials.
- Concurrent presentations of target and comparison fields or the presence of a fixation point prior to the appearance of the target may result in induction effects or chromatic adaptation that may differentially affect the perception of some wavelengths in targets that are not monochromatic.
- Many factors, including target characteristics, test conditions, and observer characteristics, have been shown to influence color appearance (CRef. 1.707).

Key References

- *1. Boynton, R. M. (1979). *Human color vision*. New York: Holt, Rinehart, and Winston.
2. Heinemann, E. G. (1955). Simultaneous brightness induction as a function of inducing- and test-field luminances. *Journal of Experimental Psychology*, 50, 89-96.

3. Jameson, D., & Hurvich, L. M. (1961). Opponent chromatic induction: Experimental evaluation and theoretical account. *Journal of the Optical Society of America*, 51, 46-53.
4. Kaiser, P. K., Herzberg, P. A., & Boynton, R. M. (1971). Chromatic border distinctness and its relation to saturation. *Vision Research*, 11, 953-968.

5. Nagy, A. L., & Zacks, J. L. (1977). The effects of psychophysical procedure and stimulus duration in the measurement of Bezold-Brücke hue shifts. *Vision Research*, 17, 193-200.
- *6. Wyszecki, G., & Stiles, W. S. (1982). *Color Science* (2nd ed.). New York: Wiley.

Cross References

- 1.706 Descriptive attributes of color appearance;
- 1.707 Factors influencing color appearance;

- 1.712 Brightness constancy;
- 1.713 Brightness induction;
- 1.717 Simultaneous color contrast;

- 6.313 Perception of chromatic and achromatic borders;
- Handbook of perception and human performance*, Ch. 9, Sects. 1.1, 3.1

1.702 Color Mixture and Color Matching

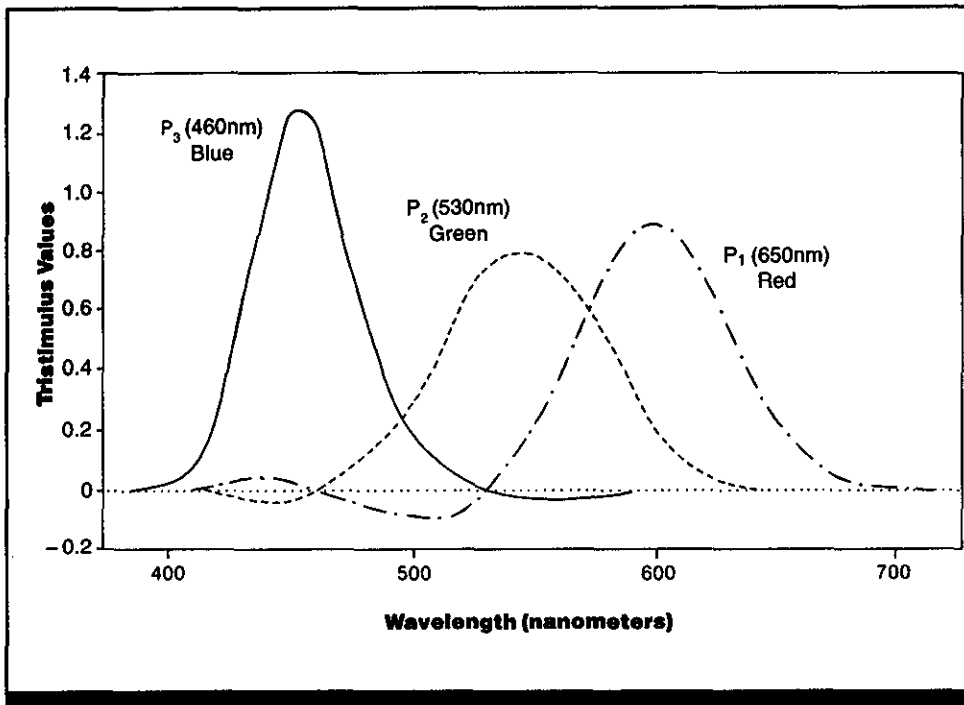

Figure 1. Tristimulus values for the equal-energy spectrum, using primaries of 650(P_1), 530(P_2), and 460 (P_3) nm. The primaries are normalized so that equal amounts of P_1 , P_2 , and P_3 match a white with a color temperature of 4800°K. The curves show the amounts of each of the three primaries required to match equal-energy spectral stimuli. (From Ref. 7)

Key Terms

Chromaticity; color matching; color mixture; colorimetry; metamerism; trichromacy; tristimulus values; WDW normalization

General Description

A human observer cannot know the spectral composition of a colored light simply by looking at it. In fact, two lights composed of very different wavelength mixtures may appear indistinguishable to the observer. In a typical color-matching task, an observer views a bipartite (or split) field, each half of which can be varied independently in spectral composition. The spectral composition of one-half of the field is then adjusted until it matches the other half in appearance. Two light patches that appear identical to the observer, although their spectral radiation is different are called a metameric pair, or metamers. (Isometric pairs, a subclass of metameric pairs, are matching lights that have identical spectral composition.)

Metameric matches have three general characteristics that allow color mixtures to be considered a linear system:

1. additivity property: when new spectral components are added to each member of a metameric pair, the two still match in perceived color, i.e., the identity relationship of the two remains intact;
2. scalar property: when the radiances of the two metamers are changed by the same amount, the pair still matches in perceived color, i.e., is still metameric;
3. associative property: if two color fields, A and B, are metamers, and so are B and C, then A and C will be metamers.

From these properties, it follows that metameric pairs will still be perceived as matching, even under a variety of viewing conditions that may alter the color appearance of the pair. For example, if a split field containing a metameric pair is surrounded by a chromatic field, the color of both members of the pair may change due to induction (CRef. 1.717), but the two will still appear identical. If the observer views the field containing the metameric pair after preexposure to a different chromatic field, the perceived hue of the pair may change, but the metamers will still appear matching.

Metamerism does not confer absolute equality for two colored fields, however. For example, for a given metameric pair, axial chromatic aberration of the eye may make one member of the pair more difficult to focus than the other, due to the particular wavelengths of which it is comprised and the refractive indices of the different ocular components. Further, at a high level of illumination, metamers may cease to appear matching. Two additional cautions are: (1) two different observers will not show the same metameric matches; and (2) when colored objects rather than colored lights are matched, metamers may cease to appear identical if the source of illumination is altered.

It is possible to match any hue using no more than three primary colors. In theory, there is wide choice in the selection of primaries. In practice, it is desirable to spectrally

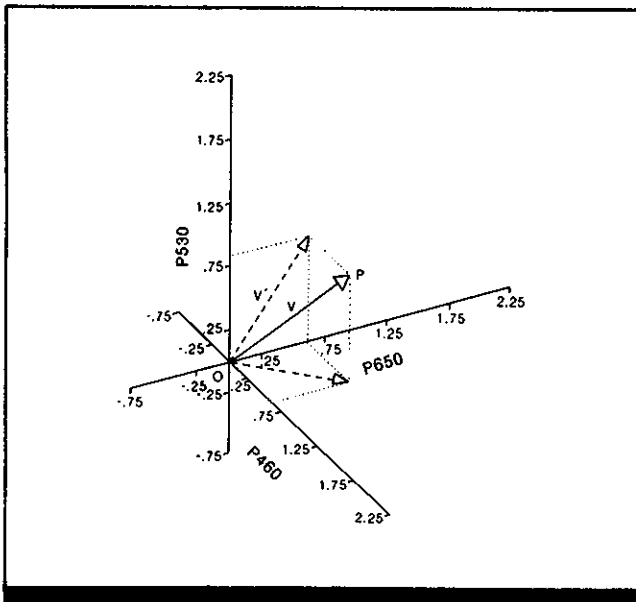

Figure 2. Three-dimensional representation of color mixture in a rectangular coordinate system. The primaries form the three axes and the color *P* is represented by the vector *V*. (From Ref. 3)

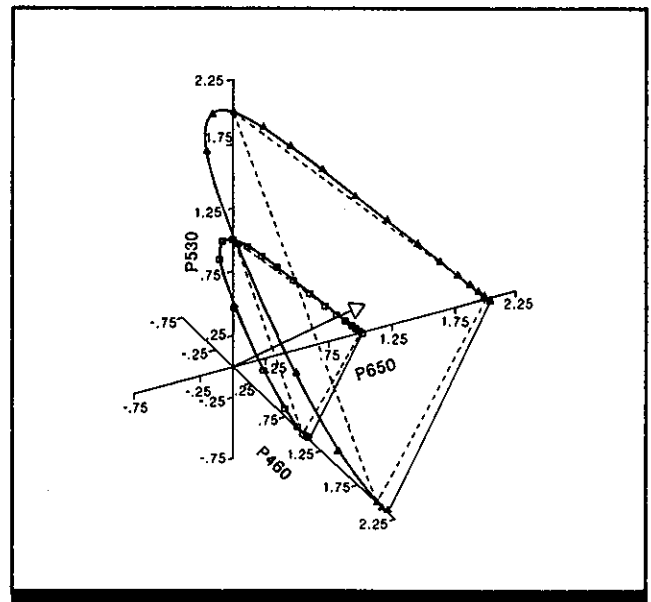

Figure 3. The spectrum locus represented in a rectangular coordinate system. Color mixture data of Ref. 5 have been normalized to a 4800° K white. The two planes represent two different radiance levels. The dashed lines enclose the region of color space that can be realized by summing various proportions of the primaries. The horseshoe-shaped curves represent the spectrum locus. Experimentally, this is realized by adding one of the primaries to the spectral light to be matched. The arrowhead of the white vector is in the higher-radiance chromaticity plane. (From Ref. 3)

separate the primaries as much as possible, although convenience usually dictates their selection. Equation 1 is used to characterize a color match; the assumption is that the primaries will be red, green, and blue although, strictly speaking, the wavelengths are largely a matter of expedience.

$$X = a_r R + a_g G + a_b B, \tag{1}$$

where a_r , a_g , and a_b are the weighting of the primaries (called the tristimulus values). In Eq. 1, the values of a can be positive, negative, or zero. When the weighting for a particular primary is zero, that component is missing from any metameric match. A negative weighting signifies that a match cannot be made even if one primary is absent, but that a given amount of energy at that wavelength must be added to the spectral composition of X to achieve a match, i.e., $X + a_r R = a_g G + a_b B$.

Representation of Color-Matching Data. There are many ways to specify the unit of measurement for the primaries. For example, both radiometric units (radiant intensity) and photometric units (luminous intensity) have been used. In the most usual method, the units for the primaries are normalized at the match to white. In this case, the amounts necessary for the three primaries (all together on one side of the colorimetric field) to match a specified white are taken as unit amounts of primary. This normalization may be thought of as reflecting the relative "coloring power" of each primary in rendering the match to white.

The amounts of the primary units (tristimulus values) which match each spectral wavelength are usually plotted for an equal-energy spectrum (i.e., equal energy of each test wavelength). The tristimulus values define a set of three functions called color-matching functions. For a set of three primaries, identified as P_1 , P_2 , and P_3 , the color-matching functions are identified as $\bar{p}_1(\lambda)$, $\bar{p}_2(\lambda)$, and $\bar{p}_3(\lambda)$.

Figure 1 shows the color-matching functions obtained by Ref. 5 using primaries of 650, 530, and 460 nm. The amounts of the primaries necessary to match any spectral wavelength can be assessed from Fig. 1.

Color Spaces. Color-matching data can also be represented in terms of vectors in a three-dimensional space. Figure 2 shows color-matching data of Fig. 1 (Ref. 7) in a Cartesian coordinate system. The coordinates are rectangular; that is, they are mutually perpendicular. Quantities of each of the primaries are represented by distances from the origin O . The location of a mixture of the three primaries is represented by the point P . This location is calculated by first calculating the vector V' from a_r , a_g in the P_{650} , P_{530} plane and then calculating the vector V between V' and the orthogonally located a_b . Figure 3 shows the same color mixture data plotted in a Cartesian coordinate system with the units of the three primary vectors expressed in terms of the normalization to white. The horseshoe-shaped curves

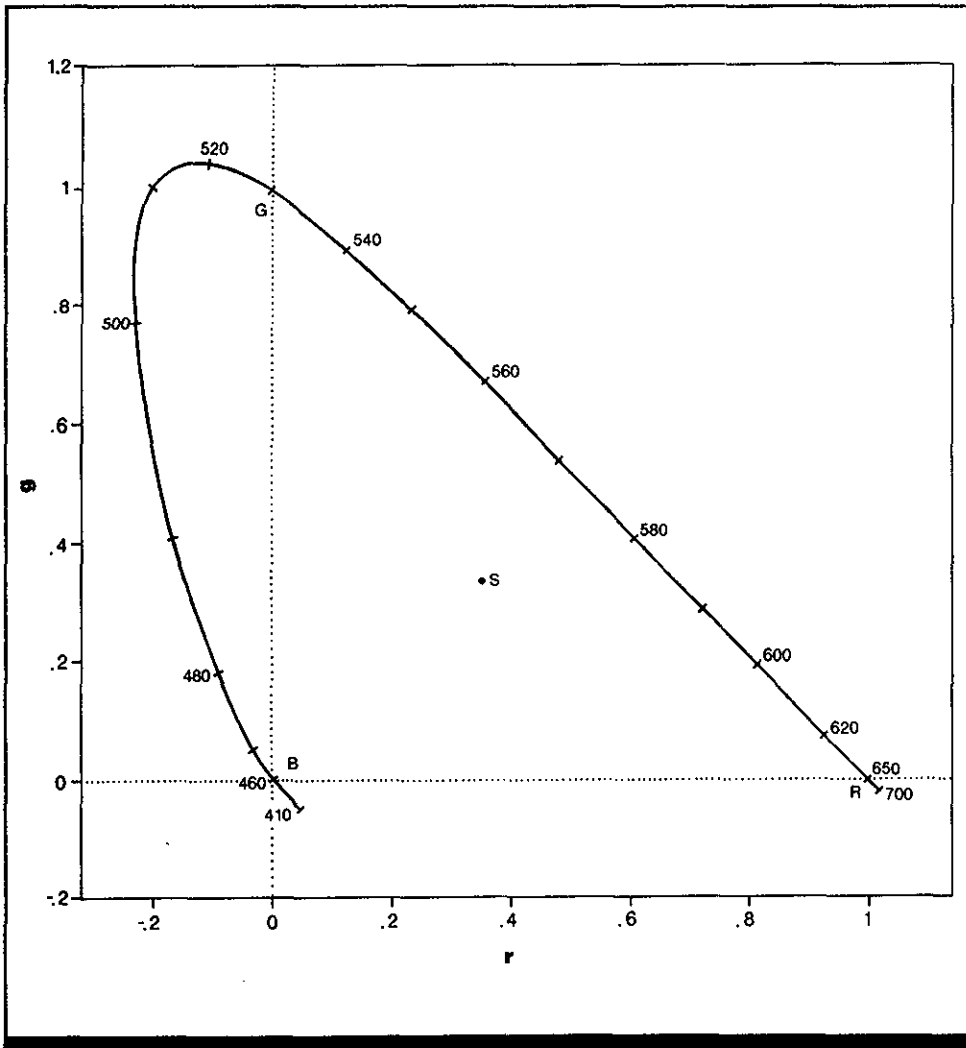

Figure 4. The spectrum locus in the chromaticity diagram for primaries at 650, 530, and 460 nm. Normalization is to a white with color temperature of 4800° K. (From Ref. 7)

depict the locus of spectral colors. The arrowhead, in the plane of higher radiance, indicates white. As a result, if the values of two of the three are known, the value of the third can be determined.

$$p_1(\lambda) = \bar{p}_1(\lambda) / [\bar{p}_1(\lambda) + \bar{p}_2(\lambda) + \bar{p}_3(\lambda)] \quad (2)$$

$$p_2(\lambda) = \bar{p}_2(\lambda) / [\bar{p}_1(\lambda) + \bar{p}_2(\lambda) + \bar{p}_3(\lambda)] \quad (3)$$

$$p_3(\lambda) = \bar{p}_3(\lambda) / [\bar{p}_1(\lambda) + \bar{p}_2(\lambda) + \bar{p}_3(\lambda)] \quad (4)$$

For the color-matching functions, $\bar{p}_1(\lambda)$, $\bar{p}_2(\lambda)$, and $\bar{p}_3(\lambda)$, the coefficients p_1 , p_2 , and p_3 are called the chromaticity coordinates (or trichromatic coefficients). If p_1 is plotted against p_2 on Cartesian axes, the values of the spectral wavelength fall on the horse-shoe-shaped curve or spectrum locus. Figure 4 shows the average data from Ref. 7 plotted in this manner.

WDW Normalization. Different observers may show different color-matching functions because of the spectral absorption characteristics of their photoreceptors (receptor variation) or because of individual differences in the absorption characteristics of the lens and macular pigment of the eye (pre-receptor variation). Reference 7 indicates a

method of normalization to separate inter-observer variability based on receptor variation from variability based on pre-receptor variation. In this method, known as WDW (W.D. Wright) normalization, two wavelengths are chosen for normalizing, one in the blue-green area and one in the yellow area (Wright used 494 and 582.5 nm). The amount of the P_1 primary is set to be equal to the amount of the P_2 primary at the first wavelength (e.g., 494 nm), and the amounts of P_2 and P_3 are set to be equal to one another at the second wavelength (e.g., 582.5 nm). Figure 5a shows the trichromatic coefficient curves for 10 observers for these two normalizing wavelengths; Fig. 5b shows the average chromaticity coordinates for these observers. The ranges of the coefficients for the 10 observers are constricted at the normalization wavelengths and at the primaries, but spread out at other wavelengths. In the chromaticity diagram, the coefficients for white are now spread out for the different observers. In comparison, the coefficients of Fig. 4 are all normalized to the white, and all subjects occupy the same locus for "white."

—Adapted from Ref. 3

Applications

Prediction of equivalent hues; specification of color mixtures.

Key References

1. Grassman, H. (1854). On the theory of compound colours. *Philosophical Magazine*, 7, 254-264. (Translated from original work published 1853)
2. Guild, J. (1931). The colorimetric properties of the spectrum. *Philosophical Transactions of the Royal Society of London*, 230A, 149-187.
3. Pokorny, J., & Smith, V. C. (1986). Colorimetry and color discrimination. In K. R. Boff, L. Kaufman, & J. P. Thomas (Eds.), *Handbook of perception and human performance: Vol. 1. Sensory processes and perception*. New York: Wiley.
4. Schrödinger, E. (1970). Grundlinien einer Theorie der Farbenmetrik im Tagessehen (Outline of a

- theory of color measurement for daylight vision). In D. L. MacLeod (Ed. & Trans.), *Source of color science*. Cambridge, MA: MIT Press. (Original work published 1920)
5. Stiles, W. S. (1955). Interim report to the Commission Internationale de l'Eclairage (CIE), Zurich, on the National Physical Laboratory's investigation of color-matching with an appendix by W. S. Stiles and J. B. Burch. *Optica Acta*, 2, 168-181.
 6. Wright, W. D. (1929). A re-determination of the trichromatic coefficients of the spectral colours. *Transactions of the Optical Society*, 30, 141-164.
 7. Wright, W. D. (1946). *Researches on normal and defective color vision*. London: Henry Kimpton.

Cross References

- 1.704 Chromaticity discrimination;
 1.705 Factors affecting color discrimination and color matching;
 1.717 Simultaneous color contrast

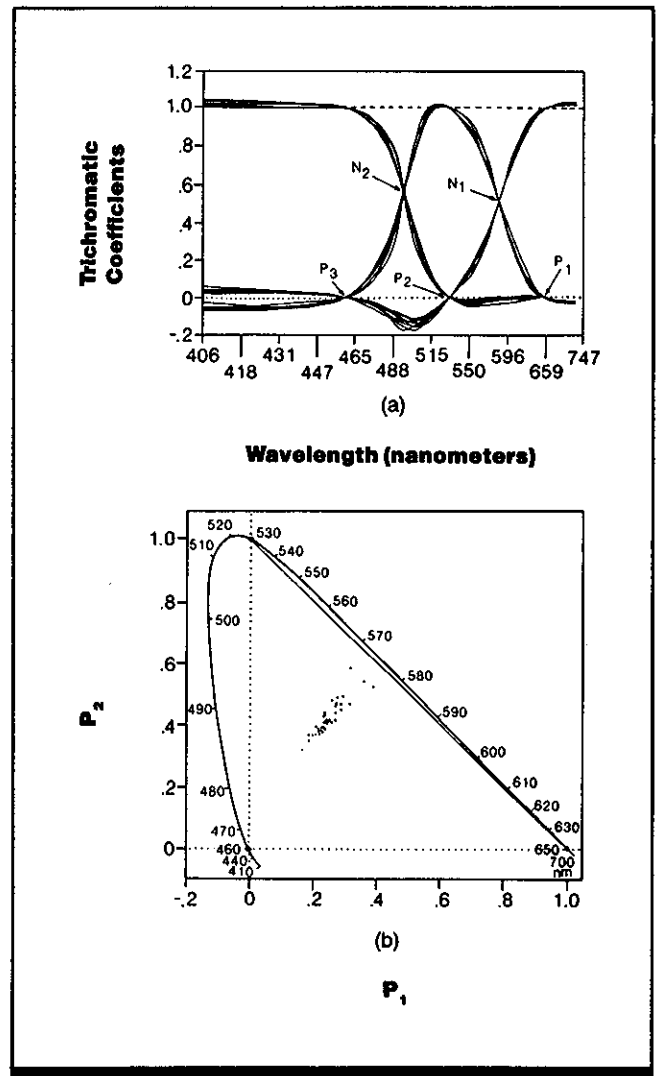

Figure 5. The WDW normalization of color mixture data. (a) Superimposed trichromatic coefficient curves for 10 observers; N_1 and N_2 are wavelengths 582.5 and 494 nm, respectively. (b) Chromaticity diagram showing the spectrum locus derived from the mean coefficient curves for the 10 observers. White chromaticity points of matches to a standard for 36 observers are shown as dots. The chromaticity diagram is plotted in terms of the matching primaries 650, 530, and 460 nm with units based on matches of 582.5 and 494 nm. The color temperature of the white stimulus was 4800° K. (From Ref. 7)

1.703 Colorimetric Purity and Excitation Purity

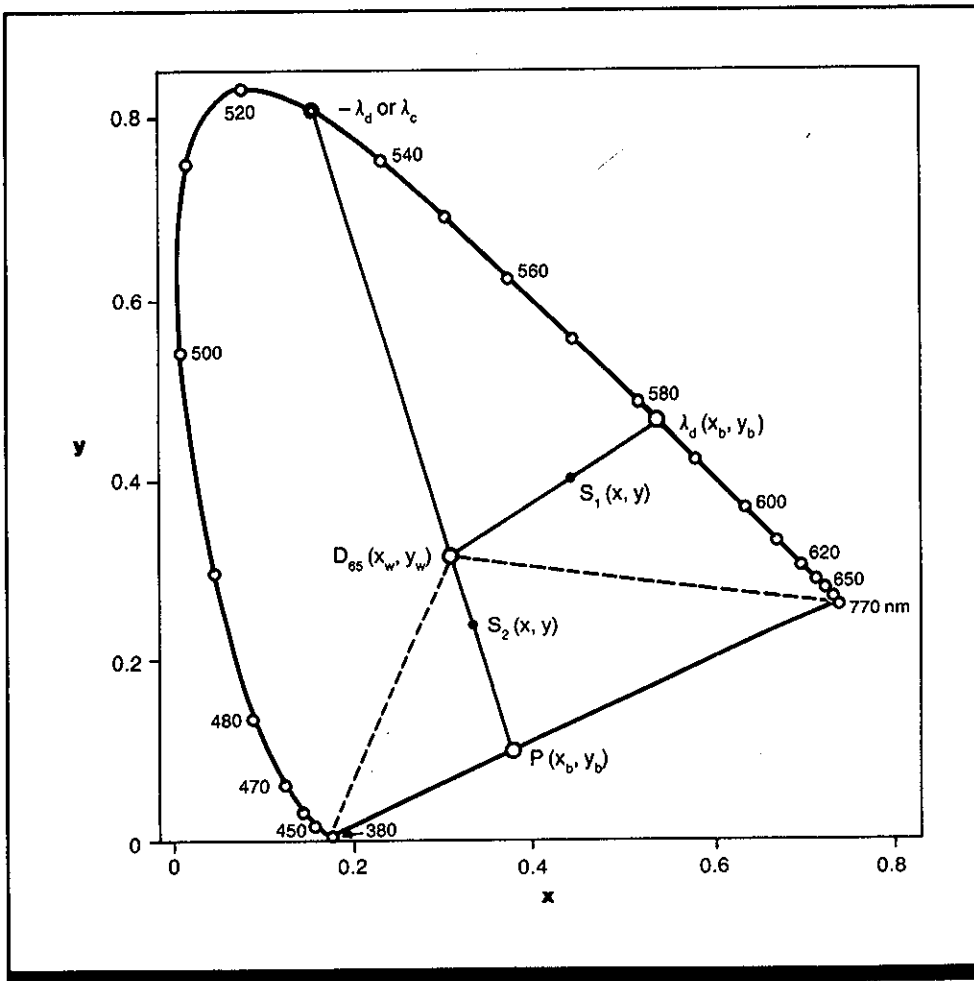

Figure 1. Representation of excitation purity on the 1931 CIE (x, y)-chromaticity diagram. Point D_{65} is a reference white with chromaticity coordinates (x_w, y_w) . The excitation purity of a light S_1 is determined by drawing a straight line from point D_{65} through the coordinates of S_1 , to the spectrum locus (point λ_d). Excitation purity is the ratio of distance from S_1 to D_{65} and the distance from λ_d to D_{65} (see Eq. 2a). The dominant wavelength of S_1 , is determined by the chromaticity coordinates at $\lambda_d (x_b, y_b)$. A line drawn from D_{65} through the coordinates of a second light, S_2 , falls not on the spectrum locus but on the line of purples (point P). The excitation purity of S_2 is determined just as for light S_1 , from the coordinates of P . The complementary wavelength of S_2 is $-\lambda_c$, or λ_c ; this wavelength can be used to characterize the light since its dominant wavelength does not fall on the spectrum locus. (From Ref. 1)

Key Terms

Colorimetric purity; colorimetry; excitation purity; saturation

General Description

Colorimetric purity refers to the amount of chromatic light added to a field composed of a specific white light. Colorimetric purity discrimination thresholds can be defined for conditions in which a spectral light is added to one-half of a bipartite (split) field in which both sides are initially isometrically (i.e., identically) white; at some level of the spectral component, the two halves are no longer perceived as identical. Results of such manipulations may be expressed in terms of colorimetric purity, P_c , as defined in Eq. 1.

$$P_c = L_\lambda / (L_w + L_\lambda) \quad (1)$$

where L_λ is the luminance of the spectral color of wavelength λ and L_w is the luminance of the achromatic, white component. Saturation is a perceptual correlate of colorimetric purity.

Colors showing a high degree of purity are also saturated, i.e., they have little white or gray in them. Saturation is commonly taken as the reciprocal of least colorimetric purity (i.e., the smallest amount of spectral light that allows a mixture of spectral light and white light to be distinguished from white); thus, as colorimetric purity at threshold decreases, saturation increases.

A related term, excitation purity, or P_e , refers to a ratio of two lengths on a chromaticity diagram: specifically the ratio of the difference in distance between the chromaticity coordinates of a standard illuminant and a particular chromatic light to the distance from the chromaticity coordinates of the standard illuminant through the comparison light to the boundary of the chromaticity diagram (spectrum locus). Colorimetric purity and excitation purity are calculated as in

Eqs. 2 and 3. Equation 4 shows the relation between the two.

$$P_e = (x - x_w)/(x_b - x_w) \quad (2a)$$

$$P_e = (y - y_w)/(y_b - y_w) \quad (2b)$$

$$P_c = (y_b/y) [(x - x_w)/(x_b - x_w)] \quad (3)$$

$$P_c = (y_b/y) P_e \quad (4)$$

x and y are the chromaticity coordinates for the test light, x_w and y_w are the chromaticity coordinates for the white standard, and x_b and y_b are the chromaticity coordinates at the spectrum locus when a line is drawn from the locus of the achromatic component through the chromaticity coordinates of the test light to the spectrum locus. Usually Eqs. 2a and 2b produce the same result, but excitation purity should be calculated using the equation producing the larger denominator. Both P_c and P_e assign colors on the spectrum locus the maximum value of 1.0 (100% purity) and the reference white the value of zero (0% purity).

Figure 1 shows how P_e can be calculated for two colors, S_1 and S_2 , with respect to a particular standard white, in this case, CIE standard illuminant D_{65} (daylight). Here, P_e equals about 65% and 30% for S_1 and S_2 , respectively. The line drawn through the coordinates of the standard white illuminant and the color S_1 , to the spectrum locus defines the

dominant wavelength of S_1 , given by $\lambda_d(x_b, y_b)$ in Fig. 1. Some lights, such as S_2 , do not have a dominant wavelength that falls on the spectrum locus. In such cases, the complementary wavelength, $-\lambda_d$ or λ_c , is used to characterize the light (two colors are complementary when their mixture in the proper proportions yields white). Purity is determined according to the lengths of lines to the nonspectral locus (line of purples), shown at point $P(x_b, y_b)$ in Fig. 1.

Purity correlates loosely with the saturation of color viewed under ordinary conditions. The correlation is not unequivocal, however, for it is well established that not all spectral colors appear equally saturated, although both P_c and P_e assign a value of 1.0 to all spectral colors. Thus, there is good correlation between purity and saturation only for colors of nearly equal luminance and of constant dominant wavelength. Excitation purity and colorimetric purity differ in that P_c for dominant wavelengths less than 460 nm produces saturation scales that are less uniform than those for P_e . Further, with P_c , purity differences near the spectrum locus are almost imperceptible while small differences near zero purity (point D_{65} in Fig. 1) are easily seen. In practice, colors are now usually specified according to their chromaticity coordinates rather than according to purity measures.

Constraints

- Experimental results for colorimetric purity discrimination are more ambiguous when purity is measured by adding white light to spectral light than when purity is measured by adding spectral light to white light.

Key References

1. Jones, L. A., & Lowry, E. M. (1926). Retinal sensibility to saturation differences. *Journal of the Optical Society of America*, 13, 25-34.
2. Kaiser, P. D., Comerford, J. P., & Bodinter, D. M. (1976). Saturation of spectral lights. *Journal of the Optical Society of America*, 66, 818-826.

3. MacAdam, D. L. (1942). Visual sensitivities to color differences in daylight. *Journal of the Optical Society of America*, 32, 247-274.
4. Martin, L. C., Warburton, F. L., & Morgan, W. J. (1933). The determination of sensitivities of the eye to differences in the saturation of colors. *Special Report Series of*

the Medical Research Council (London), 188, 5-24.

5. Judd, D. B. (1951). Basic correlates of the visual stimulus. In S. S. Stevens (Ed.), *Handbook of experimental psychology* (pp. 811-867). New York: Wiley.

6. Wright, W. D., & Pitt, F. H. G. (1934). Hue-discrimination in normal colourvision. *Proceedings of the Physical Society* (London), 46, 459-473.

7. Wright, W. D., & Pitt, F. H. G. (1937). The saturation-discrimination of two trichromats. *Proceedings of the Physical Society* (London), 49, 329-331.

8. Wyszecki, G., & Stiles, W. S. (1982). *Color science: Concepts and methods, quantitative data and formulae* (2nd ed.). New York: Wiley.

Cross References

- 1.705 Factors affecting color discrimination and color matching;
- 1.706 Descriptive attributes of color appearance;

1.707 Factors influencing color appearance;

5.401 Types of visual apparent motion

1.704 Chromaticity Discrimination

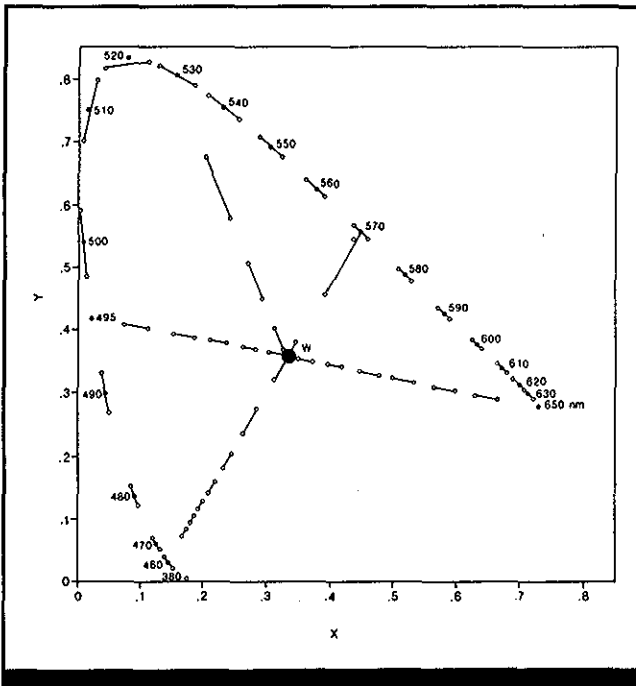

Figure 1. Chromaticity discrimination represented in the CIE 1931 chromaticity diagram. Wavelength discrimination is plotted along the spectrum locus; discrimination of colorimetric purity, along the lines intersecting the standard white (W). Each line segment represents about three just-noticeable-difference units in chromaticity for a 2-deg test field for 4 observers. (From *Handbook of perception and human performance*)

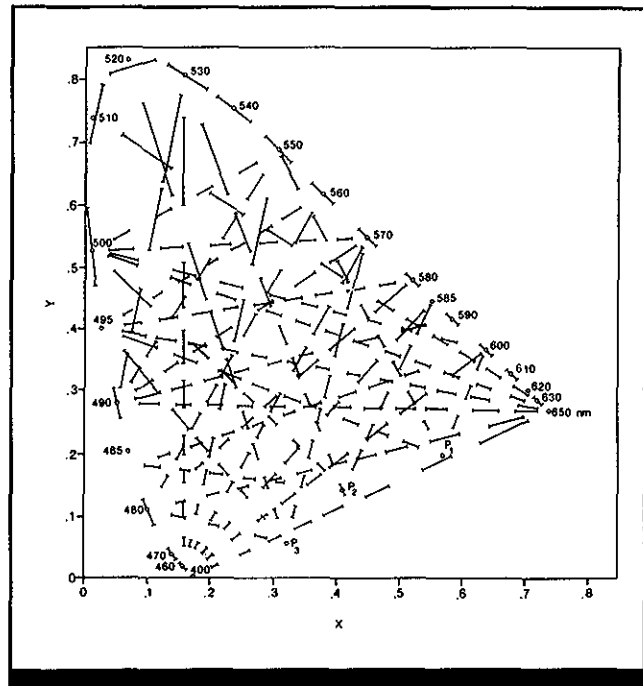

Figure 2. Subjectively equal color steps plotted on the CIE chromaticity diagram. The lines represent color differences about three times greater than the just-noticeable difference for a 2-deg field. The graph shows discrimination along a large number of color axes. (From Ref. 6)

Key Terms

Chromaticity; color discrimination; colorimetric purity; colorimetry; wavelength discrimination

General Description

An observer will detect a difference between two test lights of equal size and brightness only if the spectral compositions of the two lights differ sufficiently. The smallest chromatic difference that can be detected has been researched extensively and can be represented on a *chromaticity diagram*, as shown in Fig. 1 (Ref. 5). The data from Fig. 1 are based on a task in which observers set two halves of a small (2-deg visual angle) bipartite (split) field equal to a small, constant difference in color (about 3 **just-noticeable-difference** steps); brightness was kept equal for the two halves. Discrimination steps for wavelength are plotted on the **spectrum locus** (outer contour); steps for discrimination of **colorimetric purity**, along the axes intersecting the standard white (center of diagram).

Figure 2 shows subjectively equal color steps along a number of different axes in the chromaticity space (Ref. 6).

Each step represents a color difference about three times greater than the just noticeable difference for a 2-deg target field. As can be seen from Figs. 1 and 2, the lengths of the line segments representing equal discrimination steps are different in different regions of the diagram. Thus distances on the chromaticity diagram are not proportional to discriminability.

In Fig. 3, regions of subjectively equal color are shown by elliptical areas for a number of chromaticity points (Ref. 4). Each ellipse is equal to ten **standard deviation** units, measured in a task in which the observer adjusted one-half of a small bipartite field so that it matched the appearance of the other half, and the difference between the two settings was measured. The ellipses show considerable variability within and across observers. An example of variability in the matches of one observer tested at several times is shown in Fig. 4 (Ref. 7).

Repeatability/Comparison with Other Studies

The general nature of the color-discrimination ellipses in Fig. 3 has been confirmed by extensive experimental evaluations (Refs. 2, 7). Reference 1 tested color discrimination along several different axes in the CIE chromaticity space and found discrimination steps somewhat larger than expected on the basis of the data of Ref. 4 (Fig. 3). However, Ref. 1 used a different experimental technique in which the two halves of a bipartite field were initially matched, then one half of the field began to change in spectral composition after an unpredictable delay and the observer had to signal when the change in chromaticity could be identified.

Constraints

- The precision of an observer's chromaticity discrimination is affected by a number of different factors, including changes over time for a given observer, different chromatic responses across observers, and the wavelength of the lights being employed.
- Many factors affect chromatic discrimination and should be considered in applying these results under different viewing conditions (CRef. 1.705).

Key References

1. Boynton, R. M., & Kambe, N. (1980). Chromatic difference steps of moderate size measured along theoretically critical axes. *Color Research and Applications*, 8, 69-74.
2. Brown, W. R. J., & MacAdam, D. L. (1949). Visual sensitivities to combined chromaticity and luminance differences. *Journal of the Optical Society of America*, 39, 808-834.
3. Commission Internationale de l'Eclairage (1932). *CIE Proceedings 1931*. Cambridge, England: Cambridge University Press.
4. MacAdam, D. L. (1942). Visual sensitivities to color differences in daylight. *Journal of the Optical Society of America*, 32, 247-274.
5. Wright, W. D. (1941). The sensitivity of the eye to small color differences. *Proceedings of the Physical Society (London)*, 53, 93-112.
6. Wright, W. D. (1946). *Research on normal and defective colour vision*. London: Kimpton Medical Publishers.
7. Wyszecki, G., & Fielder, G. H. (1971). New color-matching ellipses. *Journal of the Optical Society of America*, 61, 1135-1152.
8. Wyszecki, G., & Fielder, W. S. (1982). *Color science: Concepts and methods, quantitative data and formulae* (2nd ed.). New York: Wiley.

Cross References

1.705 Factors affecting color discrimination and color matching
Handbook of perception and human performance, Ch. 8, Sect. 4.3

Figure 4. Portion of the CIE 1931 chromaticity diagram indicating differences in subjectively equal color spaces for a single observer under the same viewing conditions but with observations made at different times for test colors 9 ($x_c = 0.3310$, $y_c = 0.2749$), 11 (0.2054, 0.2544), 13 (0.3545, 0.4518), and 15 (0.3101, 0.3163). Test-retest differences were somewhat greater for two other observers tested in this study (Ref. 7) than for the observer for whom data are shown here. (From Ref. 7)

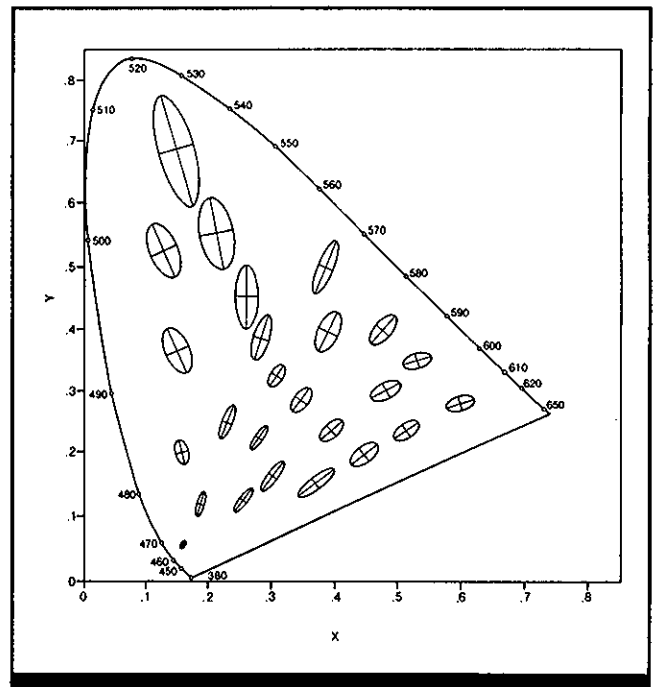
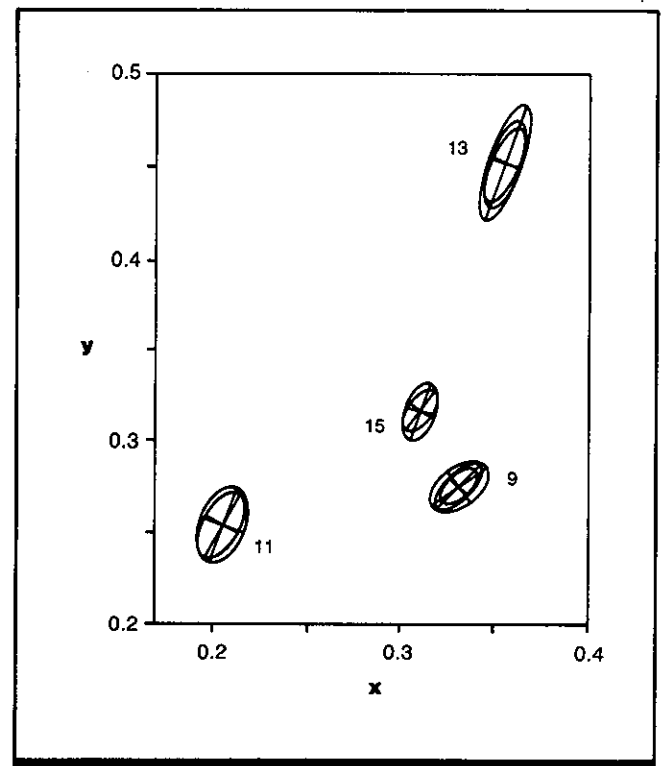

Figure 3. Subjectively equal color spaces plotted on a CIE chromaticity diagram. Ellipses represent 10 times the standard deviation of color matches measured for targets of each indicated chromaticity. The major axes of the ellipses generally correspond to axes of poor color discrimination as depicted in Fig. 2. (From Ref. 4)



1.705 Factors Affecting Color Discrimination and Color Matching

Key Terms

Chromatic adaptation; color discrimination; color matching; luminance; retinal location; stimulus duration; tritanomaly; visual field location

General Description

Many factors affect color discrimination and color matching. The factors include observer characteristics, the composition of the visual field, and conditions of viewing. These considerations are summarized in the table.

Factor	Comment	Refs.
Chromatic adaptation	Discrimination is influenced by the degree to which an observer is exposed to lights of various chromaticities. For example, color matching of two test lights is more sensitive when the surrounding field is of similar chromaticity to the test lights, although only for small test areas. The effect disappears for large (12 deg) test fields	Ref. 6
	If an adapting field is varied sinusoidally in a red-green direction, red-green discrimination will be impaired when making a color match to a white comparison field, while discrimination along the blue-yellow axis for short wavelength lights will be unaffected; likewise, modulation of an adapting light in a blue-yellow direction toward short wavelengths will affect discrimination along the blue-yellow axis, but not the red-green axis. With simultaneous modulation along red-green and yellow-blue, sensitivity is roughly uniform in elevation	Ref. 7
	For wavelengths >490 nm, discrimination deteriorates by a factor of about 1.5 when equal amounts of white and spectral lights are present, and by a factor of 3.5 with white outweighing the chromatic component by a factor of 5. For shorter wavelengths (eg., 455 nm), increasing the white component 1 to 1.5 times the chromatic element has little effect on discrimination, while further increases in white actually lead to improved discrimination	Ref. 12
	The precision of color matches in the short wavelength region of the spectrum is improved by desaturating fields with a green primary	Ref. 11
Field size, location, and fixation tasks	Some small visual fields (12 min arc) seem to produce chromatic discrimination that does not differ dramatically from larger (1 deg) fields. As the test light approximates a point source (1.5), however, discrimination deteriorates throughout the entire visible spectrum, although sensitivities to particular wavelengths do not change relative to larger fields. It should be noted, though, that fixation tasks may produce different discrimination curves than scanning, the former being the more difficult of the two and producing more variability among observers. For example, steady fixation of small fields induces poor discrimination when short wavelength lights are involved, both foveally and extrafoveally	Ref. 3
	For larger fields (>10 deg), discrimination improves by a factor of about two, although observers report an inhomogeneity in the color field at the area of fixation, the so-called Maxwell spot. This inhomogeneity forms an ill-defined ellipse with a 1 to 2 deg, horizontal major axis. In trichromatic color matches, the observer needs to ignore this spot. In tetrachromatic color matches, the spot is not apparent	Ref. 14
Luminance	In conditions of dark adaptation , observers show decreasing sensitivity to changes of test lights compared to a standard reference light in color matching tasks. For lights of varying chromaticities (e.g., blue, green, white), as luminance decreases, an observer's ability to detect changes in the test light deteriorates, at first slowly and then more rapidly. The critical point is $\sim 3.5 \text{ cd/m}^2$, above which discrimination is fairly stable and below which it begins to fall off	Ref. 6

Factor	Comment	Refs.
Luminance (cont.)	<p>With decreasing luminance, observers show symptoms of tritanopia, a pronounced weakness in discrimination along the blue-yellow axis. This effect, tritanomaly, has been well documented</p> <p>Color matches between two metameric fields hold over a wide range of retinal illumination, from about 1 to 8000 trolands; chromaticity discrimination is best at a similar range. Below 1 troland, however, the scotopic (dark-adapted) system operates, intruding into color matching and discrimination processes</p> <p>With color-defective observers, an illuminance level of 50 trolands produces rod interaction. In fact, with low retinal illuminance, even normal observers can show tritanomaly, a pronounced weakness in discrimination along the blue-yellow axis. With very high illuminance levels, normal observers can show protanomaly, a weakness in discrimination along the red-green axis</p>	<p>CRefs. 1.702, 1.704</p> <p>Refs. 2, 4, 9, 13; CRef.1.726</p>
Retinal position	<p>With peripheral stimulation, observers require larger visual fields for the perception of color</p> <p>Peripheral presentations appear desaturated compared to foveal presentations. Rod participation may also induce substantial hue changes</p>	<p>Refs. 1, 4</p> <p>Ref. 8</p>
Spatial structure	As the two halves of a bipartite field are separated, luminance discrimination deteriorates, although chromatic discrimination is either unaffected (for red-green discrimination) or actually improved (for blue-yellow discrimination)	Ref. 5
Stimulus duration	<p>Increasing presentation times in a range from 0.02 sec to 5.0 sec at low illumination levels (eg., 10.69 cd/m²) produces increasingly greater sensitivity to changes in wavelength of a test light compared to a standard. The average standard deviation among observers in one study (Ref. 10) dropped from over 0.8 nm to about 0.4 nm in a decreasing monotonic function of exposure time. Subjective reports of observers, however, indicated that long fixation times were difficult and unpleasant; these conditions would also be likely to induce several fixations, making the effective exposure time shorter than the actual time</p> <p>For practical work in color discrimination, it has been suggested that there are only significant changes in sensitivity for exposure times greater than about 0.02 sec</p> <p>Discrimination is adversely affected when two lights to be compared are presented successively rather than simultaneously. Spectral chromatic discrimination begins to deteriorate with a stimulus onset synchrony of about 60 msec and then worsens to asymptote at 5 sec</p>	<p>Ref. 10</p> <p>Ref. 12</p>

Key References

1. Abramov, I., & Gordon, J. (1977). Color vision in the peripheral retina. I. Spectral Sensitivity. *Journal of the Optical Society of America*, 67, 195-202.
2. Alpern, M. (1979). Lack of uniformity in colour matching. *Journal of Physiology*, 288, 85-109.
3. Bedford, R. E., & Wyszecki, G. W. (1958). Wavelength discrimination for point sources. *Journal of the Optical Society of America*, 48, 129-135.
4. Brindley, G. S. (1953). The effects of colour vision of adaptation

to very bright lights. *Journal of Physiology* (London), 122, 332.

5. Boynton, R. M., Hayhoe, M. M., & MacLeod, D. I. A. (1977). The gap effect: Chromatic and achromatic visual discrimination as affected by field separation. *Optica Acta*, 24, 159-177.
6. Brown, W. R. J. (1951). The influence of luminance level on visual sensitivity to color differences. *Journal of the Optical Society of America*, 41, 684-688.
7. Krauskopf, J., Williams, D. R., & Heeley, D. W. (1982). Cardinal directions of color space. *Vision Research*, 22, 1123-1131.

8. Moreland, J. D., & Cruz, A. (1959). Colour perception with the peripheral retina. *Optica Acta*, 6, 117-151.
9. Pokorny, J., & Smith, V. C. (1981). A variant of red-green color defect. *Vision Research*, 21, 311-317.
10. Siegel, M. H. (1965). Color discrimination as a function of exposure time. *Journal of the Optical Society of America*, 55, 566-568.
11. Stiles, W. S. (1955). Interim report to the Commission Internationale de l'Eclairage, Zurich, on the National Physical Laboratory's investigation of color-matching

- (1955) with an appendix by W. S. Stiles & J. M. Burch. *Optica Acta*, 2, 168-181.
12. Tyndall, E. P. T. (1933). Chromaticity sensibility to wave-length difference as a function of purity. *Journal of the Optical Society of America*, 23, 15-24.
 13. Wyszecki, G. W., & Stiles, W. S. (1980). High-level trichromatic color matching and the pigment-bleaching hypothesis. *Vision Research*, 20, 23-37.
 14. Wyszecki, G. W., & Stiles, W. S. (1982). *Color science: Concepts and methods, quantitative data and formulae* (2nd Ed.). New York: Wiley.

Cross References

- 1.702 Color mixture and color matching;

- 1.703 Colorimetric purity and excitation purity;
1.704 Chromaticity discrimination;
1.726 Congenital color defects

1.706 Descriptive Attributes of Color Appearance

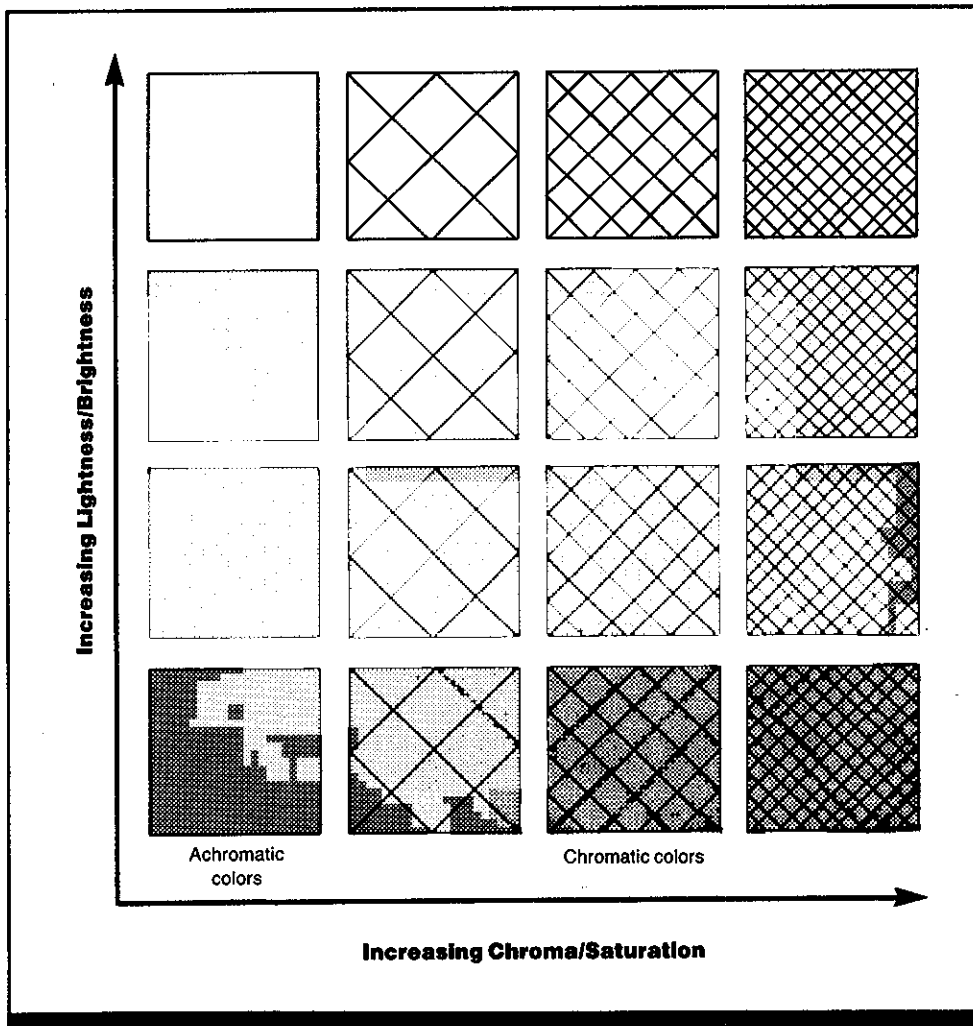

Figure 1. Variation of lightness and chroma for a constant-hue color. In this black and white simulation, the grid pattern inside the squares represents a given chromatic color (e.g., blue). The less detailed grid simulates a color with low chroma or saturation (such as pale sky blue). The more detailed grid represents the same color hue, but with high chroma or saturation (such as rich royal blue). The amount of achromatic color (varying from black through gray to white) mixed with the hue determines the degree of lightness or brightness for a given color chip (i.e., the chip with the lowest brightness and highest chroma might be dark navy blue).

Key Terms

Brightness; chroma; color appearance; color description; colorimetric purity; hue; lightness; luminance; saturation; tint; wavelength

General Description

Color is the aspect of visual perception that allows an observer to distinguish between otherwise identical objects, surfaces, or areas on the basis of different spectral compositions of radiant energy (wavelengths and wave amplitudes) emitted or reflected from them. Color appearance usually is described in terms of three basic color attributes:

Hue: the perceived color, which can be given a name such as red, yellow, blue-green, or purple. The four unique hues are those which cannot be further described using hue names other than their own: red, green, yellow, and blue. Binary or non-unique hues can be described by combining other hue names, such as reddish-yellow (orange) or bluish-red (violet). Chromatic colors possess hue; achromatic

colors are color stimuli devoid of hue, such as white, gray, or black.

Brightness or lightness: brightness refers to the degree of stimulus intensity or the level of light an area appears to emit, ranging from dazzling (very bright) to dim or very dark (often used as descriptive adjectives for the hues). Lightness usually refers to the reflectivity of a surface; that is, the amount of light the object or surface appears to emit in comparison with that emitted by a surface perceived as "white." Thus, lightness can be considered relative brightness. Lightness ranges from very light (white) to very dark (black).

Chroma or saturation: the degree of color purity or richness (apparent deviation from white). Chroma is the per-

ceived difference between a color with hue and an achromatic color of the same brightness or lightness (one in the same row on a Munsell chart; CRef. 1.724). Chroma decreases as lightness or brightness decreases. *Saturation* is the same basic attribute, but is judged independently of the lightness or brightness of the two compared colors. *Desaturation* is the addition of white pigment or light to a color so

that it becomes less rich in appearance (as in a single row on a Munsell chart).

Table 1 illustrates how radiometric, photometric, and colorimetric attributes of light influence perception of brightness, hue and saturation, and lightness.

Applications

Specification of desired color attributes for lights and luminous areas, painted surfaces, and various kinds of colored displays, such as cathode ray tubes.

Constraints

- Although the attributes given here are regarded as basic and useful for discussing color appearance, they are not a comprehensive descriptive set. For example, *colorfulness* is sometimes used to describe the degree to which an area appears to exhibit more or less chromatic color (such as when objects appear brighter and more colorful under high illumination) (Ref. 4).
- In the past, *brightness* sometimes was used as an equivalent term for *luminance*. This usage is now considered incorrect; the terms are not interchangeable—brightness is a purely perceptual term, whereas luminance is radiance weighted by a luminosity function (CRef. 1.104).
- The term *lightness* is sometimes reserved for describing achromatic surfaces only.
- In addition to the three basic perceptual attributes of color, colored objects can be specified by various physical characteristics such as spectral distribution, spatial proper-

ties (e.g., size, shape, location, texture), and temporal properties (stationary, moving, pulsing, flickering), etc.

- An observer's judgment of color appearance is seldom precise; it can vary widely depending on viewing conditions, the kind of stimuli presented, and cognitive factors (attention, memory, motivation, emotion) (CRef. 1.707).
- Color vision is due to stimulation of the **cone** cells in the eye, which are sensitive to radiant energy in the range of approximately 360 nm to 830 nm and at luminances above approximately 0.001 cd/m².
- Color vision is most vivid for large stimulus fields and moderate luminance levels; very low luminance results in **scotopic** vision with no color perception; very high luminance results in perception of objects as white.
- As the area of retinal stimulation increases or moves toward the periphery of the **retina**, observers report greater yellow and blue perception, compared to red and green.
- Very small or dim objects may appear white, especially in the 400 nm and 580 nm regions of the spectrum.

Key References

1. Burnham, R. W., Hanes, R. M., & Bartelson, C. J. (1963). *Color: A guide to basic facts and concepts*. New York: Wiley.

2. Commission Internationale de l'Eclairage (CIE) (1970). *International lighting vocabulary* (3rd ed.). Paris: CIE Central Bureau.

3. Evans, R. M. (1948). *An introduction to color*. New York: Wiley.

4. Hunt, R. W. G. (1978). Color terminology. *Color Research and Application*, 3, 79-87.

5. Judd, D. B. (1951). Basic correlates of the visual system. In S. S. Stevens (Ed.), *Handbook of experimental psychology*. New York: Wiley.

6. Munsell, A. H. (1942). *Book of color*. Baltimore: Munsell Color Book Co.

7. Wyszecki, G., & Stiles, W. S. (1982). *Color science* (2nd ed.). New York: Wiley.

Cross References

- 1.104 Measurement of radiant and luminous energy;
 - 1.707 Factors influencing color appearance;
 - 1.722 Color specification and the CIE system of colorimetry;
 - 1.724 Color-order systems: Munsell system;
- Handbook of perception and human performance*, Ch. 9, Sect. 1.0

Table 1. Correlation of perceived color with radiometric, photometric, and colorimetric attributes of light. (From Ref. 5)

Radiometric	Photometric and Colorimetric	Perceptual
Spectral radiance	Luminance	Brightness (dim to bright)
	Dominant wavelength and purity, or chromaticity coordinates	Hue and saturation, or red-green, blue-yellow
Spectral transmittance	Luminous transmittance	Lightness (dark to clear)
	Dominant wavelength and purity, or chromaticity coordinates	Hue and saturation, or red-green, blue-yellow
Spectral directional reflectance	Luminous directional reflectance	Lightness (black to white)
	Dominant wavelength and purity, or chromaticity coordinates,	Hue and saturation, or red-green, blue-yellow
	or Munsell value Munsell blue Munsell chroma	Lightness (black to white) Hue } (red-green Saturation } (blue-yellow

1.707 Factors Influencing Color Appearance

Key Terms

Achromatic induction; age; border effects; brightness; chroma; chromatic induction; color appearance; colorimetric purity; contour effects; contrast; flicker; hue; lightness; luminance; saturation; size; spectral radiance; stimulus duration; texture; wavelength

General Description

The perception of color in or on an object, a surface, or an area is affected by numerous factors. These include characteristics of the target itself (spectral content, luminance,

etc.), of the environment in which it is viewed (surround, contrast, etc.), and of the observer (age, etc.). The table lists some of these factors, describes their effects, and cites sources of more detailed information.

Applications

Selection and specification of various parameters for desired color attributes for lights and luminous areas, for painted objects and surfaces, and for monochrome or multicolored display formats.

Factor	Conditions	Effects	Constraints	Refs.
Target Characteristics				
Spectral content	Luminous colored objects or areas emitting light of various wavelengths	Systematic variation in color appearance, depending on dominant wavelength of object or area		
	Colored objects or areas illuminated by lights of various wavelengths	Systematic variation in color appearance, depending on dominant wavelengths of object and illuminant; there is more variation in hue than in saturation level	Background reflectance and lightness levels significantly influence this effect	CRef. 1.710
Luminance level	Luminous chromatic area with increasing or decreasing luminance level	Hue changes with luminance level (Bezold-Brücke effect)	Effect does not occur for the four unique hues (red, blue, green, yellow), and is attenuated for brief illumination times	CRef. 1.709
Illumination level	Colored objects or areas illuminated by lights of various illuminances	Some viewing conditions lead to perceived color changes, with changes in illumination levels		CRef. 1.709
Illumination changes	Colored objects or scene observed under changing light conditions	A change in hue is recognized and attributed to lighting conditions; after about 5 min, hue drifts back to the original (color constancy)	Process of drift back to the original hue perception is usually not complete	
Chromatic purity	An achromatic component is added to monochromatic light	Hue changes (Abney effect)	Some purple-blue and yellow lights are not affected	CRef. 1.708
Border distinctness	Adjacent homogenous light and dark fields with a distinct border	The appearance of light or dark narrow bands on the fields, parallel to and near the border (Mach bands)	Pronounced effect for achromatic fields, but not well documented for chromatic fields	CRef. 1.716
	A colored area with an indistinct ("fuzzy") border, against a white background	The area appears lighter, "softer," more translucent, and of lower chroma than when the border is sharp and distinct		

Factor	Conditions	Effects	Constraints	Refs.
Adjacent colored or achromatic fields	Two adjacent fields with different chromaticity coordinates	A distinct border is perceived between the fields, more distinct with increasing luminance difference between the fields	If edges show gradient (not a distinct border) the fields appear lighter, "softer," with lower chroma; effect varies with the color locations in the visual spectrum	CRef. 6.313
Surface texture	Area or object with a glossy or transparent surface	The degree of glossiness is correlated with the regularity of light reflection from surface; the degree of transparency is correlated with the regularity of light transmission through the surface		Ref. 3
Directionality (angle of light entry through pupil)	Colored objects presented through different parts of the pupil and imaged on the same retinal area	Variation in sensitivity to color, depending on path of light entry into the eye (Stiles-Crawford effect)	This effect is most pronounced with foveal stimulation	Ref. 1
Stimulus duration	Colored objects presented for varying durations	Hue changes with very brief exposure relative to that perceived with longer viewing times	May be a special instance of induction (see below)	CRef. <i>Handbook</i>
	Colored objects or areas illuminated for a very brief time	Perception of color may not be the same as for longer illumination times	May be a special instance of induction	CRef. 1.717
Flicker	Two similar fields with different chromaticity coordinates, presented in rapid alternation	At appropriate flicker rates, colors fuse into a hue, saturation, and brightness that is the additive mixture of the two	Modulation rates at which colors fuse and at which flicker disappears depend on luminance level, area size, retinal location, chromatic differences, and light adaptation	Ref. 6
Environment Factors				
Size of surround	A center area which is surrounded by a larger area with different color characteristics	Hue, brightness, and saturation of the center area may appear different, with different surrounds	Effect is not constant; it increases as surround area increases, especially for large surrounds	CRefs. 1.717, 1.718
Surround contrast	Colored object is brighter than the surrounding area	Under some conditions, object color appears to have no gray content and to be glowing (<i>farbenglut</i> or <i>fluorence</i> effect)		CRef. 1.711
Chromatic induction	Two close or adjacent fields with different chromatic properties, under constant illumination	The hue of one field (the test field) appears to shift away from that of the other (inducing field) instantaneously; the effect is correlated with the closeness of the fields	With complex visual patterns, sometimes the two hues appear more similar rather than more different (color assimilation)	CRefs. 1.717, 1.713
Achromatic induction	Two adjacent fields with different chromatic properties, where one increases in brightness while the other remains constant	Instantaneous impression that constant-brightness field has grown less bright	Although brightness of the constant field decreases, lightness may remain constant	CRefs. 1.712, 1.713
Observer Characteristics				
Age	Humans with normal color vision, in a color matching task	Ages 20-24 have best color discrimination; irregular decline with age	Blue/yellow sensitivity often decreases with age, due to narrowing of pupil and to changes (yellowing) of the lens	Ref. 7
Visual defects	Humans with congenital or acquired (illness-caused) color vision deficiencies, in a color matching task	About 8% of males and 1% of females have color deficiencies; red-green (deuteranopia, protanopia) is most common; yellow-blue (tritanopia) is rare	Congenital and acquired defects may have the same diagnostic label, but may exhibit different effects	Ref. 7

Constraints

• The appearance of a colored area is influenced by nearby areas. For example, two adjacent areas may interact to produce apparent lightness changes (Mach bands) (CRef. 1.716). Two patches of light in a center-surround arrangement may exert reciprocal influences in the form of enhanced contrast between the center and surround

or, with more complex patterns, a reduction of contrast known as color assimilation (CRef. 1.717, 1.718).

- For very indistinct borders between the target and its background, prolonged, fixated viewing of the target may cause the contrast between the target and the background to decrease to zero, making the target disappear.
- Color appearance is influenced by many other target characteristics and by viewing conditions.

Key References

1. Crawford, B. H. (1972). The Stiles-Crawford effects and their significance in vision. In D. Jameson & L. M. Hurvich (Eds.), *Visual psychophysics*. New York: Springer-Verlag.

2. Ishak, I. G. H. (1952). Determination of the tristimulus values of

the spectrum for eight Egyptian and one British observer. *Journal of the Optical Society of America*, 42, 844-849.

3. Judd, D. B. (1951). Basic correlates of visual stimulus. In S. S. Stevens (Ed.), *Handbook of experimental psychology*. New York: Wiley.

4. McCollough, C. (1965). Color adaptation of edge detectors in the human visual system. *Science*, 149, 1115-1116.

5. Sweeney, E. J., Kinney, J. A. S., & Ryan, A. (1960). Seasonal changes in scotopic sensitivity. *Journal of the Optical Society of America*, 50, 237-240.

6. van der Horst, G. J. C. (1969). Chromatic flicker. *Journal of the Optical Society of America*, 59, 1482-1488.

7. Verriest, G. (1963). Further studies on acquired deficiency of color discrimination. *Journal of the Optical Society of America*, 53, 185-195.

Cross References

1.706 Descriptive attributes of color appearance;

1.708 Hue; effect of saturation changes (Abney effect);

1.709 Hue: effect of luminance level (Bezold-Brücke effect);

1.710 Hue and chroma: shifts under daylight and incandescent light;

1.711 Fluorescence of color glow;

1.712 Brightness constancy;

1.713 Brightness induction;

1.715 Model of brightness contrast;

1.716 Mach bands;

1.717 Simultaneous color contrast;

1.718 Color assimilation;

1.722 Color specification and CIE system of colorimetry;

6.313 Perception of chromatic and achromatic borders;

6.318 Feature-selective adaptation and masking;

6.320 Contingent aftereffects;

Handbook of perception and human performance, Ch. 9, Sect. 2.

Notes

✓

✓

✓

✓

1.708 Hue: Effect of Saturation Changes (Abney Effect)

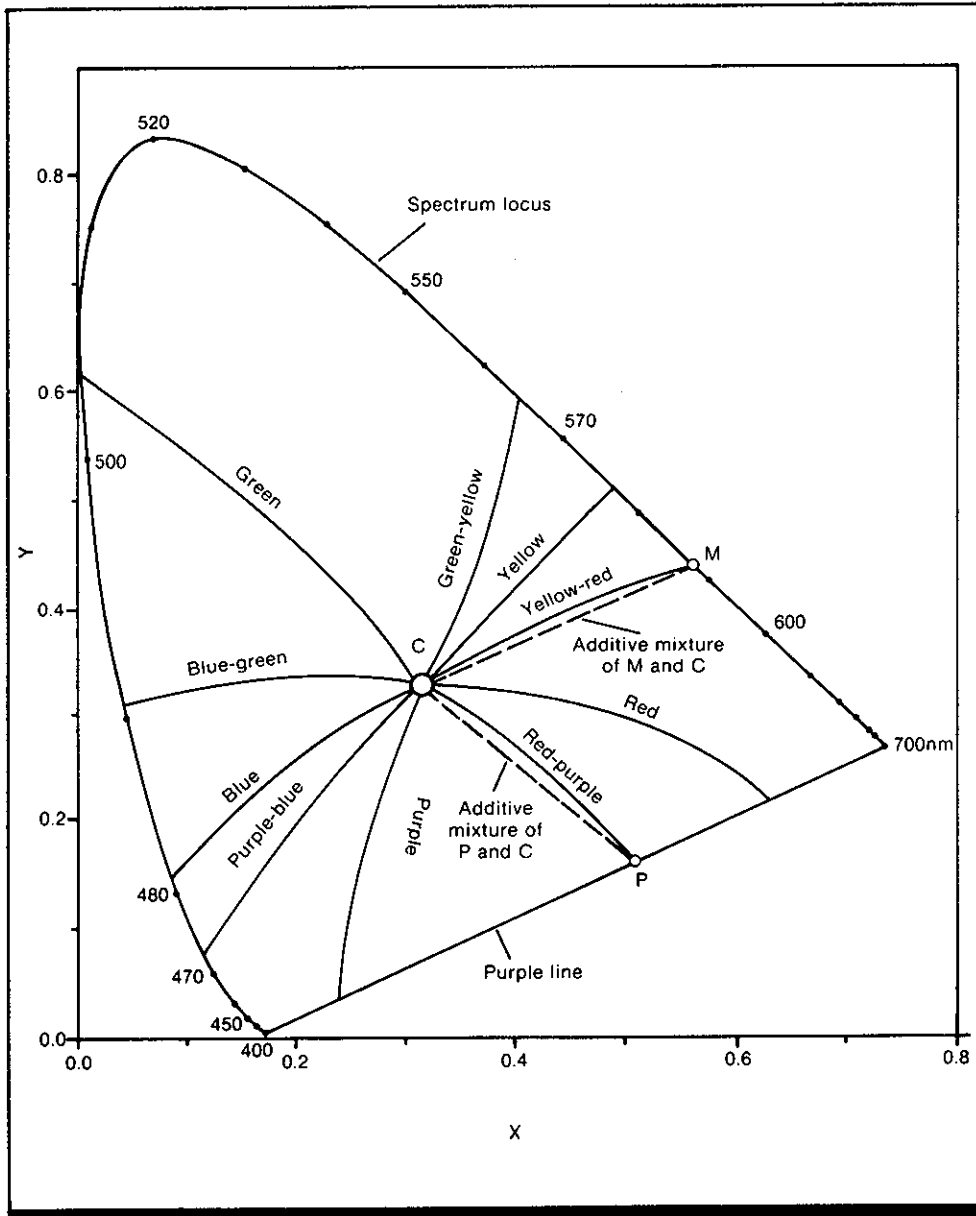

Figure 1. CIE 1931 (x, y) chromaticity diagram, with solid lines representing color mixtures that have constant hue. Excitation purity is maximal for colors whose coordinates lie on the spectrum locus and falls to zero at point C. (From *Handbook of perception and human performance*)

Key Terms

Abney effect; chroma; color appearance; color mixture; excitation purity; hue; saturation; tint

General Description

Changes in the **saturation** (or excitation purity) of a colored object, surface, or area are accompanied by changes in its hue (Abney effect). For example, adding white light to (desaturating) a red light that is highly saturated produces a

color that is more yellowish, as well as less saturated (closer to pink). When hue constancy is desired, the **dominant wavelength** of the color mixture must be adjusted whenever excitation purity level is changed. This effect is illustrated on the CIE 1931 (x, y) **chromaticity diagram** in Fig. 1. Lines of *constant hue* are represented by curved lines

radiating from the central **achromatic** (white) point, C ($x = .310, y = .316$), which corresponds to CIE standard illuminant C . These are connected either with a location on the purple line, such as P , or with a location of **monochromatic** light on the **spectrum locus**, such as M .

If exact hue constancy is not required, the Abney effect can be ignored. In this case, it is usually satisfactory to merely hold dominant wavelength constant. The two

dashed, straight lines in Fig. 1 are lines of constant dominant wavelength.

The Abney effect does not occur for all dominant wavelengths. The perception of a bluish-purple of ~ 562 nm and a yellow of ~ 570 nm is not affected by changes in excitation purity, as is shown by the two solid straight lines at those wavelengths.

Applications

Selection and specification of desired hues at various saturation levels (excitation purities) for colored lights, painted surfaces, and colored display formats, either when hue constancy is desired or when specific differences in hue must be assured; use, interpretation, and updating of color-specifi-

cation systems such as the CIE chromaticity diagrams (CRef. 1.722), Munsell system (CRef. 1.724), and OSA system (CRef. 1.725); compensation for the effects of ambient illumination striking the surface of self-luminous displays.

Constraints

- Figure 1 should be regarded as an approximation because of its reliance on color judgments, lack of data for some areas on the chromaticity diagram, and the extrapolation of curves to reach the spectrum locus; curves were selected which best fit the data and, when in doubt, straightness rather than curvature was preferred (Ref. 4).
- Brightness as well as hue varies with changes in excitation purity; hue can vary with changes in luminance (CRef. 1.709).

- The shape of constant hue lines depends on the chromaticity of the desaturating stimulus; daylight and tungsten lighting give different results (Ref. 2, CRef. 1.710).
- An observer's judgment of color appearance is seldom consistent; it can vary widely, depending on viewing conditions, the kind of stimuli presented, and cognitive factors (attention, memory, motivation, emotion) (CRef. 1.707); background reflectance/luminance significantly influences estimates of constant hue loci, as does the degree of observer adaptation to the surround (Ref. 4).

Key References

*1. Abney, W. de W. (1910). On the change of hue of spectrum colors by dilution with white light. *Proceedings of the Royal Society of London*, A83, 120-127.

*2. MacAdam, D. L. (1950). Loci of constant hue and brightness determined with various surrounding colors. *Journal of the Optical Society of America*, 40, 589-595.

3. MacAdam, D. L. (1951). Influence of visual adaptation on loci of constant hue and saturation. *Jour-*

nal of the Optical Society of America, 41, 615-619.

*4. Newhall, S. M., Nickerson, D., & Judd, D. B. (1943). Final report of the O.S.A Subcommittee on the spacing of the Munsell colors.

Journal of the Optical Society of America, 33, 385-418.

5. Robertson, A. R. (1970). A new determination of lines of constant hue. In M. Richter (Ed.), *Color 69*. Göttingen: Muster-schmidt-Verlag.

Cross References

1.703 Colorimetric purity and excitation purity;
1.706 Descriptive attributes of color appearance;
1.707 Factors influencing color appearance;

1.709 Hue: effect of luminance level (Bezold-Brücke effect);
1.710 Hue and chroma: shifts under daylight and incandescent light;
1.722 Color specification and the CIE system of colorimetry;

1.724 Color-order systems: Munsell system;
1.725 Color-order systems: Optical Society of America System;
Handbook of perception and human performance, Ch. 9, Sect. 2.1

1.709 Hue: Effect of Luminance Level (Bezold-Brücke Effect)

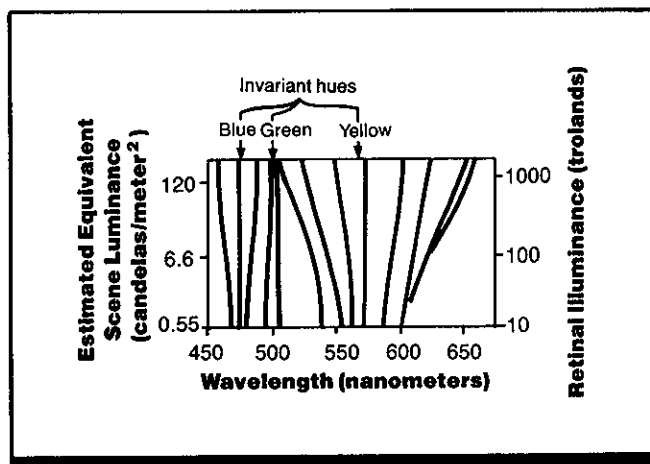

Figure 1. Contours of constant hue (Study 1). All combinations of luminance and wavelength lying along a given contour have identical hue. There is no shift in hue with luminance changes for three wavelengths: 572 nm (yellow), 503 nm (green), and 478 nm (blue). (From Ref. 5)

Key Terms

Bezold-Brücke effect; color appearance; hue; luminance

General Description

The hue of a target depends upon both wavelength and luminance. If the luminance of a target is varied, with wavelength held constant, its perceived color (hue) changes (the Bezold-Brücke effect). There are three wavelengths that show no hue shift with changes in luminance; which precise wavelengths these are varies according to whether the target is presented as a steady-state light or as a brief flash. With steady-state presentation, the invariant hues fall around 475, 507, and 570 nm; with flashes, the values are somewhat lower (bluer), approximately 470, 504, and 555 nm. The Bezold-Brücke effect is attenuated when very brief pulses of light are used rather than steady-state lights. The greatest effect appears with long-wavelength targets as they converge toward invariant yellow (572 nm); smaller hue shifts are associated with short wavelengths as they converge on invariant blue (478 nm).

Applications

Selection and specification of desired hues at various luminance levels for colored lights, painted surfaces, and colored display formats, either when constancy of hue is desired or when specific differences in hue are necessary (as for color coding).

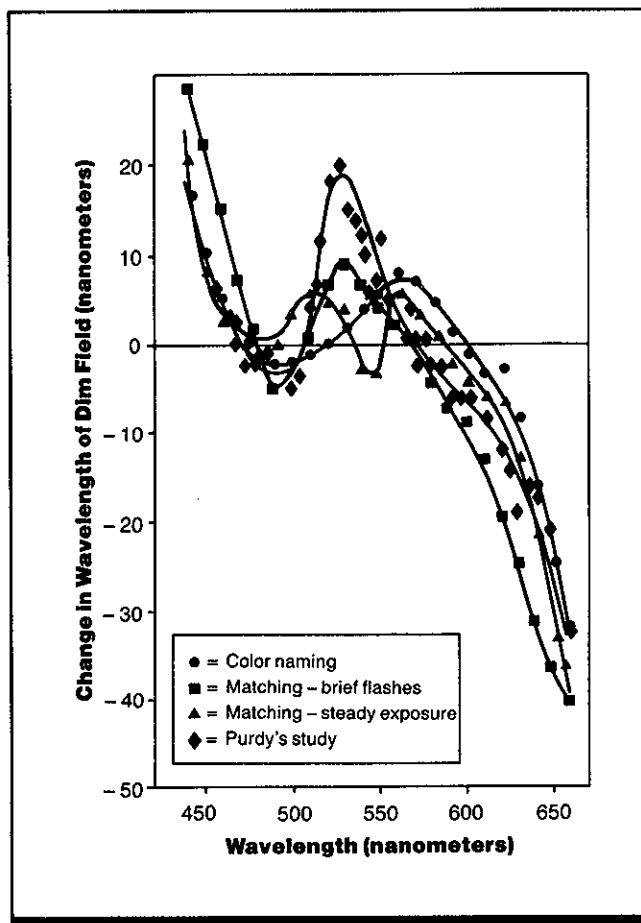

Figure 2. Hue shift with change in luminance. The ordinate shows the change in wavelength of a dim (6.6 cd/m^2) target required for it to match in hue a bright 120 cd/m^2 target of the wavelength shown on the abscissa. Data are given for a color-matching task with brief targets (Study 2), a color-matching task with continuous (steady) targets (Study 2), and a color-naming task with brief targets (Study 3); for comparison, data from Ref. 5 (Purdy) are shown for a color-matching task with continuous targets. (From Ref. 1)

Methods

Test Conditions

Study 1 (Ref. 5)

- Lights of 460-660 nm wavelengths
- Circular 3-deg target, divided in half vertically
- Pairwise comparisons between hues at the following luminance levels: 280 and 35; 280 and 6.6; 35 and 6.6; 35 and 1.2; 6.6 and 0.55 cd/m²

Study 2 (Ref. 1)

- Lights of wavelength 440-660 nm in 10 nm steps, presented in random order; observers dark-adapted for 5 min
- Circular 3-deg target, divided in half vertically, superimposed upon fixation point; presented in Maxwellian view; 120 cd/m² (1000 trolands) comparison field

on left, 6.6 cd/m² (100 trolands) test field on right

- Head held immobile via bite board
- Presentation time: either indefinite (until match completed) or 300-msec flashes with 9 sec between flashes (number of flashes unspecified—probably as many as desired by observer)

Study 3 (Ref. 1)

- Same as Study 2, except single uniform circular 3-deg target, flashed for 300 msec; luminance 120 or 6.6 cd/m²
- Presentation time: 300 msec with 12 msec between flashes

Experimental Procedure

Study 1

- Independent variable: wavelength of comparison light
- Dependent variable: wavelength

of test light needed to match hue of comparison light

- Observer's task: adjust monochromatic test light to match monochromatic comparison light, first with test light of higher wavelength than comparison light and then with test light of lower wavelength than comparison light
- 1 observer

Study 2

- Independent variable: wavelength of comparison field (the brighter light)
- Dependent variable: wavelength of dimmer test field selected by observer to match hue of comparison field
- Observer's task: adjust wavelength of continuously presented test field by turning unmarked knob until test target's hue matched that of comparison light
- 3 male observers with normal color vision

Study 3

- Independent variables: wavelength of target, target luminance
- Dependent variable: target hue, measured by weighting for the presence of one or two of the hues (red, yellow, green, and blue) at each wavelength (three points assigned to each trial, with all three points going to one hue for response involving only one color name and with two points to dominant hue, one to lesser hue for responses involving two color names)
- Observer's task: name color of target using only the hue names red, yellow, green, or blue, or some ordered pair of these names (e.g., "blue-green" to denote a target appearing primarily blue with a lesser amount of green)
- Same observers as Study 2

Experimental Results

Study 1

- The hue associated with a given wavelength of light changes as luminance changes. The direction and magnitude of the change depends upon wavelength (Fig. 1).
- A long-wavelength test light (>574 nm) becomes more red as luminance decreases. A dim light will match the hue of a bright light only if the wavelength of the dim light is lower than that of the bright light.
- Between wavelengths of 574 and 507 nm, decreasing luminance of test light causes hue to become more greenish; the maximum hue shift in this region is at ~525 nm. Within this region, an observer must increase the wavelength of a dim light relative to that of a brighter light to achieve a hue match.
- Short-wavelength light (i.e., 476-507 nm) becomes greener with lower luminance; to match the hue of a dim light to that of a bright light, the dim light must be lower in wavelength.
- Below ~476 nm, the hue shifts toward violet from blue as luminance decreases; a dim test light must be of higher wavelength to achieve the same hue as a bright light.
- Hue is independent of luminance at ~572 nm (yellow), 503 nm (green), and 478 nm (blue).

Study 2

- With continuous display of target, results (given in Fig. 2) are similar to those found in Study 1: hue shifts as luminance changes except for targets of ~480, 508, and 567 nm.
- For briefly presented targets, the hue shift caused by luminance change is attenuated, reflecting a relative weakening of the perception of reds and greens compared to yellow and blues. Also, both long and short wavelength lights tend to be less reddish than with steady exposure conditions, and the typical hue shift at ~550 nm for steady-state targets is missing (Fig. 2).

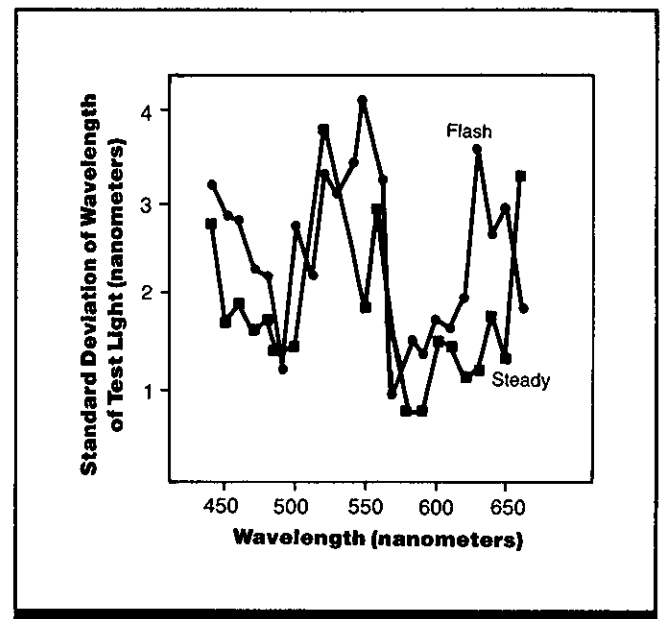

Figure 3. Variability of color matching with continuous (steady) and brief (flash) targets. Average of standard deviations (in nanometers) of three subjects for color-matching data shown in Fig. 2 (Study 2) is given as a function of wavelength. (From Ref. 1)

Study 3

- When a color-naming procedure is used to measure hue shift for brief targets, long wavelength lights appear more yellow at high luminance than at low luminance, while short wavelengths appear more red at low luminance than at high.

Variability

No information on variability was given for Study 1. For Study 2, the mean standard deviation for all subjects across wavelengths is 2.8 nm for flashes and 2.2 nm for steady-state presentations. The average of standard deviations as a function of wavelength is given in Fig. 3. For Study 3, all split-half reliability correlation coefficients for even versus odd trials associated with each invariant hue for each of the observers exceed 0.90, with a mean correlation coefficient

of ~0.96. Color naming is slightly more reliable at lower luminances than at higher luminances. Among the three test conditions in Studies 2 and 3 (color naming, color matching with flashed targets, color matching with continuous targets), discrepancies between color naming and flash matching data are smaller than between any other pair of conditions.

Constraints

- In the region around 508 nm, desaturation influences comparison of hues.
- Small visual fields produce results at variance with findings for larger fields. For non-monochromatic, two-component lights with large luminance differences between the spectral components, the dimmer of the two components shows a dramatic hue shift. In such cases, the observers are not always able to compensate for the effects of widely differing luminances in matching tasks.
- Matching tasks with pulsed flashes may produce different induction effects than tasks with steady-state targets, resulting in different hues with changes in presentation times. The Bezold-Brücke effect may be weakened for longer-duration presentation because of a perceived diminution of

the reddish and greenish components of the target over time. The reddish and greenish components also grow more slowly with increasing luminance, so that with brief targets, these two colors may not be perceived as strongly as with longer durations.

- Noticeable changes in hue can occur due to various induction effects, such as occur with color assimilation (CRef. 1.718), color contrast (CRef. 1.717), or due to the nature of the border separating the fields; this type of effect has been shown to affect hue of adjacent color fields for long-duration exposures and may also occur even with brief exposures.
- A number of other factors affect color appearance and should be considered in applying these results under different conditions (CRef. 1.707).

Key References

*1. Boynton, R. M., & Gordon, J. (1965). Bezold-Brücke hue shift measured by color-naming technique. *Journal of the Optical Society of America*, 55, 78-86.

2. Coren, S., & Keith, B. (1970). Bezold-Brücke effect: Pigment or neural locus. *Journal of the Optical Society of America*, 60, 559-562.

3. Larimer, J., Krantz, D. H., & Cicerone, C. M. (1974). Opponent-process additivity. I. Red/green equilibria. *Vision Research*, 14, 1127-1140.

4. Nagy, A. L., & Zacks, J. L. (1977). The effects of psychophysical procedure and stimulus duration in the measurement of the

Bezold-Brücke hue shifts. *Vision Research*, 17, 193-200.

*5. Purdy, D. M. (1931). Spectral hue as a function of intensity. *American Journal of Psychology*, 43, 541-559.

*6. Purdy, D. M. (1937). The Bezold-Brücke phenomenon and contours for constant hue. *American Journal of Psychology*, 49, 313-315.

7. Van der Wildt, G. J., & Bouman, M. A. (1968). The dependence of Bezold-Brücke hue shift on spatial intensity distribution. *Vision Research*, 8, 303-313.

8. Walraven, P. L. (1961). On the Bezold-Brücke phenomenon. *Journal of the Optical Society of America*, 51, 1113-1116.

Cross References

1.707 Factors influencing color appearance;

1.708 Hue: effect of saturation changes (Abney effect);

1.717 Simultaneous color contrast;

1.718 Color assimilation

Notes

1.710 Hue and Chroma: Shifts Under Daylight and Incandescent Light

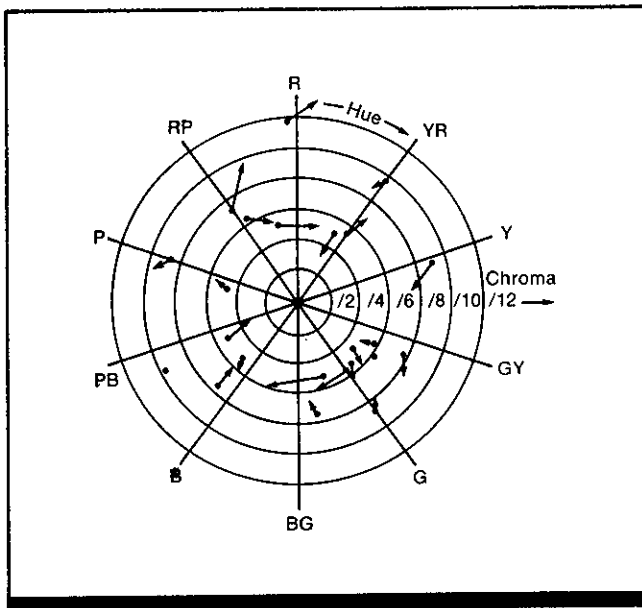

Figure 1. Changes in hue and chroma with changes in state of chromatic adaptation. Lines of constant hue are radii originating at the center and lines of constant chroma are concentric circles; the greater the radius of the circle, the higher the chroma. Shown in this diagram are the observed shifts in color appearance of Munsell color samples of medium Munsell value when the observer's state of adaptation is changed from daylight (CIE source C; arrow tails) to tungsten light (CIE source A; arrow heads). The data shown are representative of those obtained in Ref. 5. (From Ref. 6)

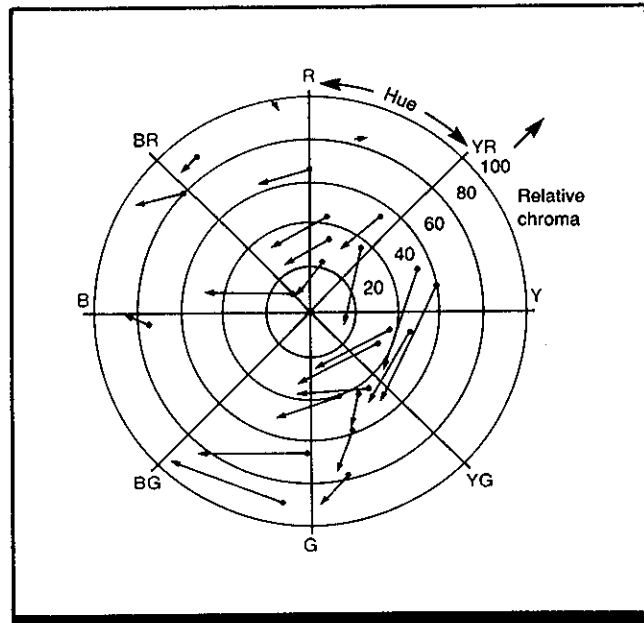

Figure 2. Change in hue and chroma of 1 deg arc colored test samples with illumination change from daylight (CIE D_{65} ; arrow tails) to tungsten light (CIE source A; arrow heads) (data from Refs. 1, 3). Samples were surrounded by a very high reflectance background field. (From Ref. 2)

Key Terms

Brightness; chroma; chromatic adaptation; chromaticity; color appearance; colorimetric purity; hue; illumination level; lightness; saturation; Von Kries coefficients

General Description

An object or area viewed under daylight will be perceived to have different hue, **lightness**, and **chroma** than the same object or area viewed under incandescent (tungsten filament) light. This is due both to colorimetric shift (changed spectral distribution of the radiant flux leaving the object) and to adaptive shift (chromatic adaptation) of the eye, or the adjustment of the visual system to changes in the spectral distribution (wavelength) of light. Resultant color shifts have been mapped for daylight and some artificial illumination conditions.

Perceived differences in **chromaticity** of Munsell color chips (CRef. 1.724) with medium chroma, when viewed under CIE standard light sources C (average daylight) and A (tungsten light) (CRef. 1.107) against a white background, are illustrated in Fig. 1. Six well-practiced observers were completely adapted to each kind of light, in turn, and re-

ported perceived colors in terms of memorized descriptions of hue and chroma. Each arrow starts at the perceived hue and chroma in daylight, and ends at perceived values for the same Munsell sample under tungsten light.

Figure 2 shows changes in hue and chroma for 24 circular test areas, each 1 deg arc of visual angle in diameter and surrounded by a high-reflectance (1000 cd/m^2) field. The colored test areas had luminance of 200 cd/m^2 . Seven observers were adapted for 20 min to a uniform daylight source (CIE standard D_{65} with luminance of at least 200 cd/m^2), then gave direct magnitude estimations of hue and chroma for the test areas (presented for 2 sec at 10 sec intervals) illuminated by that source. The process was repeated using illumination from a tungsten source (CIE standard A). Each arrow starts at hue and chroma judgments in daylight and ends at the judgments for the same sample under incandescent illumination.

The *von Kries coefficient law*, as modified by Bartleson (Ref. 3), permits prediction of how the hue and chroma of a test area seen under one lighting condition will change when seen under another. The model assumes that the visual mechanism contains three fundamental sensitivity processes which remain invariant in relative spectral distribution. Changes in spectral quality of illumination alter the fundamental sensitivities in inverse proportion to the strength of their activation by the illuminant.

Applications

Predicting expected changes in the hue and chroma of an area or object when it will be seen under various lighting conditions (primarily those of daylight and of incandescent lighting); selecting and specifying chromaticity coordinates for samples that will elicit the same color appearances when the observer is adapted to different conditions ("corresponding colors"); evaluating the color-rendering properties of artificial lights; evaluating the color reproduction characteristics of photographs viewed under varying conditions.

Constraints

- An observer's judgment of perceived color can vary widely depending on viewing conditions, the kind of stimuli presented, and cognitive factors (attention, memory, motivation, emotion) (CRef. 1.707); judgments based on short-duration viewing of dim or intensely bright objects are especially variable.
- Research on chromatic adaptation has been done systematically primarily for illuminant changes from daylight to incandescent lighting.
- Predictions from the model for daylight adaptation are relatively poor in the yellow region of color space.
- Judgments of the color of textured papers show much more color constancy than do those of colored lights, because specular reflection cues about nature of the illumination enable the observer to discount the illuminant in judging color.
- The degree of observer adaptation to background luminance significantly affects chromatic judgments; adaptation is the result of a weighted mean of the luminance of all objects in the field of view, but is largely determined by the background.

Key References

1. Bartleson, C. J. (1977). A review of chromatic adaptation. In F. W. Billmeyer Jr., & G. Wyszecki (Eds.), *Color 77*. Bristol, England: Adam Hilger.
2. Bartleson, C. J. (1977). *Factors affecting color appearance and measurement by psychophysical methods*. Unpublished doctoral

dissertation, City University of London.

- *3. Bartleson, C. J. (1979). Changes in color appearance with variations in chromatic adaptation. *Color Research and Application*, 4, 119-138.
- *4. Bartleson, C. J. (1979). Predicting corresponding colors with

changes in adaptation. *Color Research and Application*, 4, 143-155.

5. Helson, H., Judd, D. B., & Warren, M. H. (1952). Object-color changes from daylight to incandescent filament illumination. *Illuminating Engineering*, 47, 221-223.
- *6. Judd, D. B., & Wyszecki, G. (1975). *Color in business, science,*

and industry (3rd ed.). New York: Wiley.

7. Stiles, W. S. (1961). Adaptation, chromatic adaptation, color transformation. *Anales de la Real Sociedad Española de Física y Química*, 57, 149-175.

8. Wyszecki, G., & Stiles, W. S. (1982). *Color science* (2nd ed.). New York: Wiley.

Cross References

- 1.107 Color temperature;
- 1.706 Descriptive attributes of color appearance;

- 1.707 Factors influencing color appearance;

- 1.708 Hue: effect of saturation changes (Abney effect);

- 1.709 Hue: effect of luminance level (Bezold-Brücke effect);

- 1.722 Color specification and the CIE system of colorimetry;

- 1.724 Color-order systems: Munsell system;

Handbook of perception and human performance, Ch. 9, Sect. 4.2

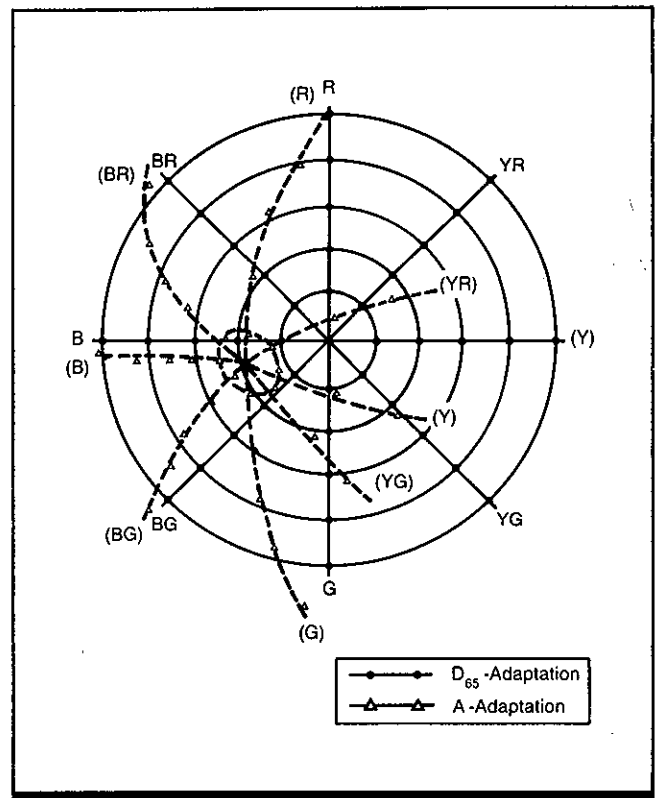

Figure 3. Superimposed color-appearance diagrams for D_{65} adaptation (solid dots) and for A adaptation (open triangles), derived from data given in Fig. 2. A triangle in the A-adaptation diagram indicates the color appearance of a test stimulus viewed under D_{65} adaptation that, under A adaptation, would have the same color appearance as the corresponding solid dot in the D_{65} -adaptation diagram. (From Ref. 2)

- Chromatic adaptation has been measured under a variety of conditions and with many different techniques, including color naming, magnitude estimation, binocular color matching, and monocular color matching; resulting chromatic shifts differ at least in part due to the techniques and conditions used.

1.711 Fluorence or Color Glow

Key Terms

Brightness; color glow; Farbenglut; fluorence; fluorescence

General Description

The apparent brightness of a target is not totally dependent on the absolute level of target illumination. A patch of light ringed by a bright surround appears black under conditions of low or no illumination, but gradually loses its darkness and becomes chromatic with a noticeable gray content as illumination increases. At some point, as illumination rises further, the test patch loses its grayish cast and becomes a pure hue. As illumination continues to increase, the patch begins to be fluorent (i.e., to have a fluorescent appearance; sometimes known as *Farbenglut* or "color glow"). Finally, as the luminance of the patch increases still further, the patch appears to be illuminant (a light source) (Fig. 1). The luminance required for the patch to appear fluorent varies with the wavelength of the illuminating light: the luminance necessary for fluorence decreases as wavelength increases from 450 nm to ~580 nm and then increases with longer wavelengths (Fig. 2). The threshold for fluorence is very dependent on the chromaticity of the surround (Fig. 3) but relatively independent of the luminance of the surround.

Applications

Displays incorporating visual alerting mechanisms.

Methods

Test Conditions

Study 1 (Ref. 2)

- 53.3 × 66.0 cm (21 × 26 in.) white, gray, or black surround viewed from 76.2 cm with normal binocular vision; surround luminance of ~318 cd/m² (100 mL)
- Test field at center of surround was 2.2 × 2.5-cm aperture filled by colorimetric mixture; aperture subtended 2 deg vertically
- Colorimetric test-field purity could be varied from zero to maximum available; test-field luminance could be varied over a 100 to 1 range
- Dominant wavelength of test field at maximum purity (produced by Wratten filters) was 452.7, 491.9, 524.1, 583.6, or 605.5 nm

Study 2 (Ref. 4)

- 1 deg central test field with a 10-deg surround; chromaticity varied for both test field and surround
- For white background, surround luminance varied from approxi-

mately 160 to ~1590 cd/m² (50-500 mL); color temperature 7000° K; surround also presented at luminance of ~318 cd/m² and color temperature of 3000° K

- Surrounds of 17 different colors presented at ~318 cd/m² luminance.
- 16 different colors of test field used

Experimental Procedure

Study 1

- Within-subjects design
- Independent variables: Munsell value (brightness) and colorimetric purity of the test field
- Dependent variable: luminance levels associated with changes in perceived quality of stimulus (Fig. 1)
- Observer's task: (1) adjust purity of test field to match amount of grayness in test field to that of nearby comparison field with specified level of grayness; (2) adjust luminance of test field until it was perceived to be free of gray, but was just below level required for

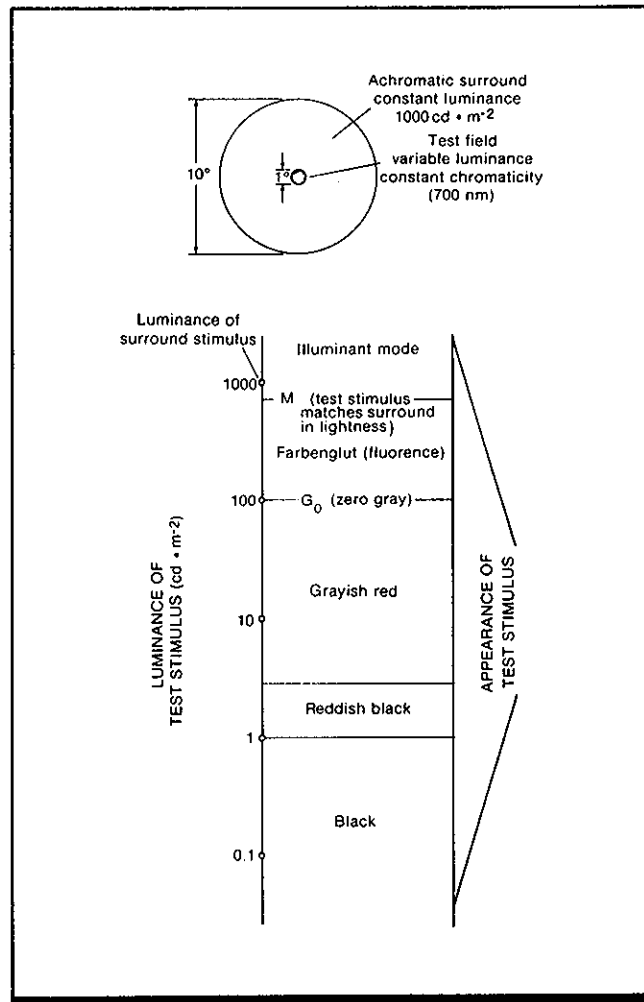

Figure 1. Pattern of changes in the appearance of a monochromatic (reddish) test target of varying luminance surrounded by an achromatic (white) field of constant luminance (Study 1). G_0 is the threshold for fluorence (fluorescence). (From *Handbook of perception and human performance*)

fluorence; (3) identify equal brightness levels for test field compared to different-colored surround; and (4) mark luminance point for each level of purity of test field at which appearance changed from surface mode to illuminant mode

- 1 observer with normal color vision; another observer with anomalous color vision (deuteranomaly; CRef. 1.726) also participated in similar secondary experiment

Study 2

- Independent variables: chromaticity of test field, chromaticity of surround, surround luminance, color temperature
- Dependent variable: fluorence threshold, G_0 , defined as $\log(L_S/L_T)$, where L_S is the luminance of the surround and L_T is the luminance of the test field at which fluorence first appears
- Observer's task: not described
- Number of observers not reported

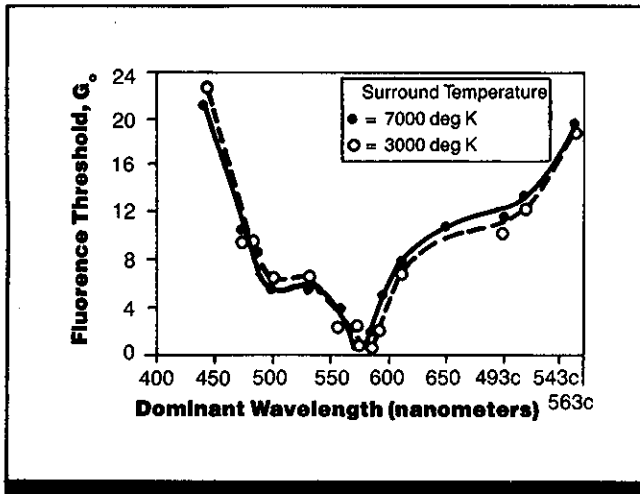

Figure 2. Fluorence threshold G_0 as a function of dominant wavelength of the test field for one observer (Study 2). Color temperature of the surround was either 7000° K or 3000° K. (Wavelength followed by the letter "c" denotes complements of colors which lie along the line of purples.) Note that G_0 must equal zero when the luminance of the test field equals the luminance of the surround, since G_0 is measured as the log of the ratio of surround luminance to test field luminance. (From Ref. 5)

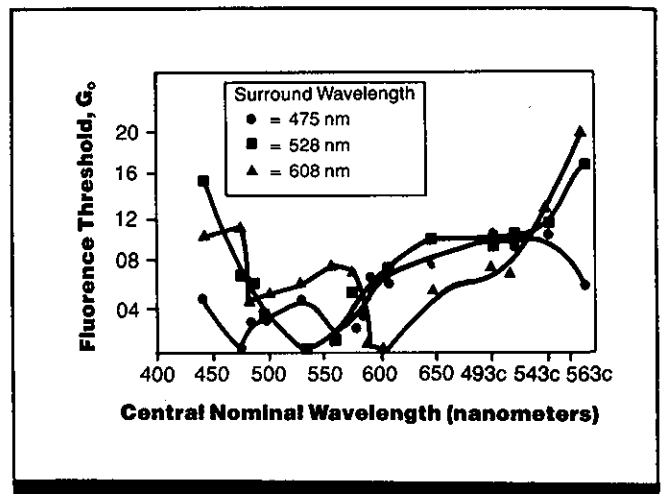

Figure 3. Fluorence threshold G_0 as a function of nominal wavelength of the test field (central spot) for surrounds of three different colors. (From Ref. 5)

Experimental Results

- For a target of given purity (saturation), as target luminance increases relative to the luminance of its surround, observers report seeing first a black target (at very low target luminance), then a colored patch with decreasing grayness, followed by fluorence or color glow (fluorescence), and finally, when the luminance of the target exceeds that of the surround, illuminance (Fig. 1).
- The data for a deuteranomalous observer (able to distinguish blues and yellows, but confuses reds and greens) are similar to the data for an observer with normal color vision.
- The threshold for fluorence (G_0) generally decreases as dominant wavelength increases up to ~580 nm; above 580 nm, fluorence threshold increases as wavelength increases (Fig. 2).
- Changing the color temperature of the surround from

7000° K to 3000° K does not change the shape of the function, but only shifts it slightly to the right in the yellow part of the spectrum. Thus any gray appearance of a color stimulus will be similar in daylight and artificial light.

- Fluorence threshold is independent of surround luminance within the test range (~160 - 1590 cd/m²).
- For a constant surround luminance, fluorence threshold changes as the chromaticity of the surround changes. As shown in Fig. 3, the differences in the functions for different-colored surrounds are fairly dramatic.

Variability

In Study 1, there were large individual differences in the luminance values associated with the thresholds for each type of effect, but the order of the various thresholds was the same as shown in Fig. 1 for all observers. No information on variability was given in Study 2.

Constraints

- Thresholds for changes in gray content, fluorescence versus illuminant mode, etc., can vary according to the observer's mode of fixation: constant viewing of test patch, constant viewing to the side of the patch, or consistent

movement of the eyes. Flash exposure of the target may produce a more controlled procedure for inducing fluorence.

- Color appearance is influenced by many target characteristics and viewing conditions (CRef. 1.707).

Key References

1. Boynton, R. M. (1975). Color, hue and wavelength. In E. C. Carterette, & M. P. Friedman (Eds.), *Handbook of perception: Vol. V. Seeing* (pp. 301-350). New York: Academic Press.

*2. Evans, R. M. (1959). Fluorence and gray content of surface colors. *Journal of the Optical Society of America*, 49, 1049-1059.
 3. Evans, R. M. (1974). *The perception of color*. New York: Wiley.
 *4. Evans, R. M., & Swenholt, B. K. (1969). Chromatic strength

of colors, III. Chromatic surrounds and discussion. *Journal of the Optical Society of America*, 59, 628-634.
 5. Hurvich, L. M., & Jameson, D. (1955). Some quantitative aspects of an opponent-colors theory: II. Brightness, saturation, and hue in normal and dichromatic vision.

Journal of the Optical Society of America, 45, 602-616.
 6. Jameson, D., & Hurvich, L. M. (1955). Some quantitative aspects of an opponent-colors theory: I. Chromatic responses and spectral saturation. *Journal of the Optical Society of America*, 45, 546-552.

Cross References

1.707 Factors influencing color appearance;

1.709 Hue: effect of luminance level (Bezold-Brücke effect);
 1.710 Hue and chroma: shifts

under daylight and incandescent light;
 1.717 Simultaneous color contrast;

1.726 Congenital color defects; *Handbook of perception and human performance*, Ch. 9, Sect. 1.4

1.712 Brightness Constancy

Key Terms

Brightness; brightness constancy; Brunswik ratio; color appearance; contrast; lightness; lightness constancy; luminance

General Description

Under normal viewing conditions, the **lightness** of an object or area (i.e., its relative whiteness, grayness, or blackness) remains fairly constant despite large changes in the illumination that falls on the object and its background. For example, a white square embedded in a black square will appear white in both moonlight and sunlight, even though the amount of light reflected from the surface of the white square in moonlight is actually less than the amount of light emitted from the surface of the black square in bright sunlight. This effect is called *lightness constancy*.

Figure 2 shows equal brightness contours for a test field surrounded by a background or inducing field in the configuration shown in Fig. 1. The figure shows the luminances of the test field (L_T) and the background field (L_I) at which the lightness of the test field matched that of a comparison field of fixed lightness. When lightness constancy holds, the data fall along a straight line with a slope of 1.0 (i.e., the luminances of test field and background field must be increased equally to maintain constant test-field lightness; L_T/L_I is constant). As can be seen from the figure, lightness constancy fails (L_T/L_I varies) when the background is much dimmer than the test field but holds at least approximately with increased background luminance.

The *Brunswik ratio* has been used as an index of lightness constancy. It is defined as

$$b = \frac{B_c - B'_T}{B_T - B'_T}$$

where B_T is the reflectance of a gray test stimulus receiving an illumination of E , and therefore having luminance L ; B'_T is the reflectance of another gray sample receiving an illumination of $E' \neq E$ such that the luminance of the second sample $L' = L$ (i.e., the reflectances of the two samples are different, but their luminances are the same because they

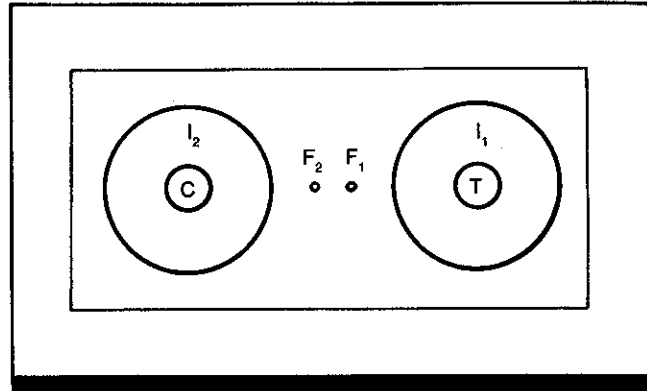

Figure 1. Visual display for lightness constancy experiment of Fig. 2. The test field T , inducing field I_1 surrounding it, and the fixation point F_1 were presented to the observer's right eye only. The comparison field C and the fixation point F_2 were presented to the left eye only; in half the sessions, an inducing field (I_2) surrounded the comparison stimulus and in half the sessions the comparison had a black surround (no inducing field). (From Ref. 3)

are viewed under different levels of illumination); B_c is the reflectance of a comparison gray stimulus that matches the test stimulus in lightness at illumination level E' .

The ratio b is maximal (1.0) when the lightness of the test field is constant, despite the change in illumination; that is, under illumination E' , the comparison must have the same *reflectance* as the test stimulus to match it in lightness ($B_c = B_T$); b is minimal (0.0) when the reflectance of the comparison field under illumination E' must be such as to make the *luminance* of the comparison field match the *luminance* of the test field ($B_c = B'_T$).

In other words, if the observer perceives that a difference in the luminances of test and comparison fields is due to differences in illumination, the observer will judge two targets as being the same if their reflectances are equal. Otherwise, the observer will ignore the effect of illumination changes and judge the targets as the same only if their luminances are equal. In most experimental situations, the observer's perceptions fall between these two extremes.

desired (such as in lighting, painting, or otherwise treating a surface when lightness homogeneity is important), or when specific differences in lightness are necessary (such as for lightness coding in visual displays).

Applications

Selection and specification of reflectance, luminance, and illumination levels for objects and areas and for their backgrounds or surrounds, either when lightness constancy is

Methods

Test Conditions

- Test configuration as shown in Fig. 1; circular test and comparison fields, each 28 min of visual angle; test and inducing field presented to observer's right eye; comparison field (with inducing field or black background) presented to left eye
- Central fixation point so fields appeared side by side; artificial pupils of 2.75 mm, viewing distance of 2.53 m

- Comparison field luminance held constant for each session, but in different sessions luminance ranged from 0.2 cd/m² to 140 cd/m² (-1.20 to 1.65 log mL); in half of sessions, comparison field had black surround; in other half, comparison surrounded by inducing field of 35.7 cd/m²
- Inducing field luminance varied in 9 or 10 progressively higher steps, from 0 (black) to 100 or 320 cd/m² during each experimental session

- Observers dark-adapted for 20 min
- Luminance measured with MacBeth illuminometer, not corrected for differences in response of the two eyes
- Six experimental sessions per observer, eight matches per observer per inducing or test field luminance level

Experimental Procedure

- Method of adjustment
- Independent variables: lumi-

- nance of test or inducing field, luminance of comparison field
- Dependent variable: luminance of test field when perceived to match lightness of comparison field
- Observer's task: match lightness of test and comparison fields by varying the luminance of the test field (for comparison with no surround) or the inducing field surrounding the test field (for comparison with inducing field)
- 2 practiced observers

Experimental Results

- When the comparison field has a black surround, the test field luminance needed to match the lightness of a fixed comparison field is almost constant at low levels of induction field luminance.
- At higher levels of inducing field luminance and/or comparison fields with a surrounding inducing field, the test field luminance needed to match a constant comparison field increases with increasing levels of the inducing field.
- When the luminance of the inducing field is higher than that of the test field, lightness remains approximately constant when the ratio L_T/L_I remains constant (i.e., lightness constancy holds).

Variability

No information on variability was given, but averaged values from the two observers appear reasonably consistent. Several naive observers also were tested; results did not differ in any consistent way from those of the experienced observers.

Constraints

- Lightness constancy is an *approximate* phenomenon; actual values vary from individual to individual.
- Numerous factors influence induction effects and can yield unexpected or unpredictable results; e.g., lightness constancy contours will not always hold if the test and comparison fields are widely separated, if test and comparison are not observed simultaneously and for the same duration, or if illumination is not uniform.
- Although the *lightness* of a field may remain fairly constant when both its luminance and that of its surround are increased, its brightness may change (Ref. 9).
- The Brunswik ratio is based on object reflectance and holds best for achromatic objects. To apply it to *color constancy*, three separate ratios are required, expressing differences in hue, chroma, and lightness (Ref. 7).
- Some researchers prefer the Thouless ratio (Ref. 8) over

Key References

1. Beck, J. (1972). *Surface color perception*. Ithaca, NY: Cornell University Press.
2. Graham, C.H., & Brown, J. L. (1965). Color contrast and color appearance. In C. H. Graham (Ed.), *Vision and visual perception*. New York: Wiley.
- *3. Heinemann, E. G. (1955). Simultaneous brightness induction as

- a function of inducing- and test-field luminance. *Journal of Experimental Psychology*, 50, 89-96.
4. Hochberg, J. (1971). Perception. I. Color and shape. In J. W. Kling & L. A. Riggs, (Eds.), *Woodworth and Schlosberg's experimental psychology* (3rd ed.). New York: Holt, Rinehart & Winston.
 5. Hurvich, L. M., & Jameson, D. (1966). *The perception of bright-*

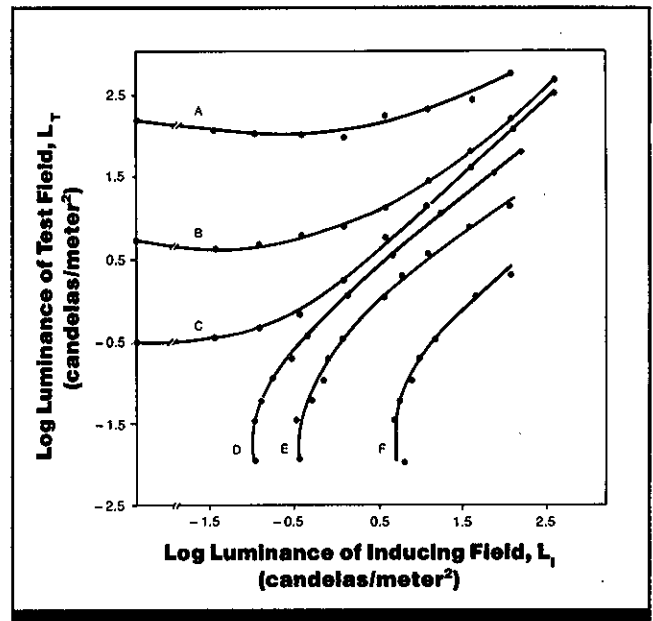

Figure 2. Test field luminance (L_T) at which the test field matched in lightness a comparison field of fixed luminance, as a function of the luminance of the inducing field (L_I). Curves A, B, and C are for three levels of comparison field presented on a black background; curves D, E, and F are for three levels of comparison field presented against a background of 35.7 cd/m². Data shown are for one observer. Lightness constancy is represented by the segments of the curves where points fall along a line with a slope of ~ 1.0 . (From Ref. 3)

the Brunswik ratio; in this index B_c , B_T , and B'_T are replaced by their logarithms; other variants of the Brunswik index involve luminance rather than the reflectance of the fields.

- ness and darkness. Boston: Allyn and Bacon.
6. Jameson, D., & Hurvich, L. M. (1964). Theory of brightness and color contrast in human vision. *Vision Research*, 4, 135-154.
 7. Newhall, S. M., Burnham, R. W., & Evans, R. M. (1959). Influence of shadow quality on color appearance. *Journal of the Optical Society of America*, 49, 909-917.

8. Thouless, R. H. (1931). Phenomenal regression to the real object. *British Journal of Psychology*, 21, 339-359.
9. Wyszecki, G. (1986). Color appearance. In K. R. Boff, L. Kaufman, & J. P. Thomas (Eds.), *Handbook of perception and human performance: Vol. 1. Sensory processes and perception*. New York: Wiley.

Cross References

- 1.713 Brightness induction;
 1.715 Model of brightness contrast;
 1.721 Lightness scales;
Handbook of perception and human performance, Ch. 9, Sects. 3.1, 3.5.1

1.713 Brightness Induction

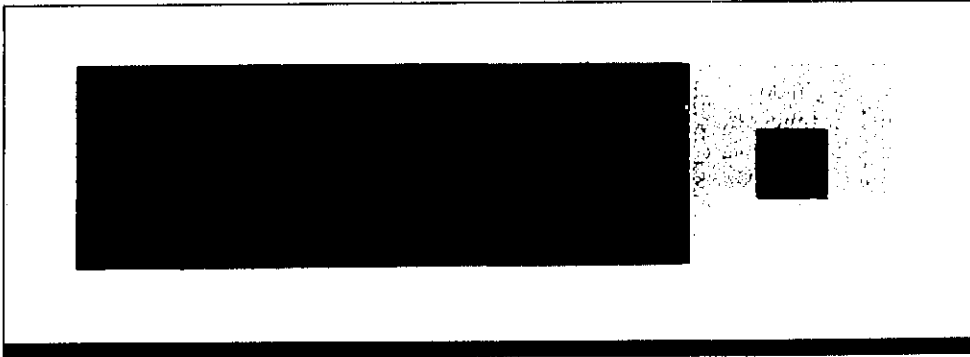

Figure 1. Example of lightness induction. All of the small squares have the same reflectance, but appear to have different lightnesses because they lie on backgrounds of different reflectances. (From *Visual perception* by T. N. Cornsweet, Copyright © 1970 by Academic Press. Reproduced by permission of Harcourt Brace Jovanovich, Inc.)

Key Terms

Achromatic induction; brightness; brightness induction; color appearance; lightness; lightness induction; luminance; simultaneous brightness contrast; spatial contrast

General Description

An area or object of fixed **luminance** or **reflectance** appears to increase or decrease in **lightness** or **brightness** when the luminance or reflectance of the area surrounding it is decreased or increased. This effect is called either *lightness* or *brightness induction*, depending on whether the target appears to reflect or emit light, respectively.

An example of lightness induction is shown in Fig. 1. The four small squares (test fields) have identical reflectances, yet their lightnesses appear different due to differences in the reflectances of the four backgrounds (inducing fields).

Figure 2 shows the results of an experiment in which the luminance of the test field is held constant while the luminance of the inducing field is gradually increased, and the observer adjusts the luminance of a separate matching field so that its lightness matches that of the test field. As the luminance of the inducing field is increased, starting from a very low level that appears black (i.e., luminance thresh-

old), the lightness of the test field increases. (Increases in the luminance of the test field from zero to threshold will obviously produce no induction because these changes will not be visible.) Eventually, though, this trend reverses and, once the inducing field's luminance reaches approximately half that of the test field, the test field regains its original lightness. As the luminance of the inducing field increases still further beyond this point, the lightness of the test field diminishes very rapidly and it soon appears black. Figure 2 is representative of data that have been collected for test fields having luminances ranging from approximately 0.1 to 113 cd/m². In cases such as those described above, where lightness induction causes the differences in the lightnesses of the test and background fields to increase, the effect is usually called *lightness contrast*. In other cases, induction leads to a decrease in lightness differences. This effect is called *reverse contrast*, *assimilation*, or *equalization*.

Lightness induction is influenced by a number of factors as summarized in Table 1.

Applications

Selection and specification of reflectance, luminance, and illumination levels for areas and objects and for their backgrounds, when constancy of brightness or lightness is desired (as in lighting, painting, or otherwise treating a surface when brightness homogeneity may be important) or when specific differences in brightness or lightness are necessary (as for brightness coding in visual displays).

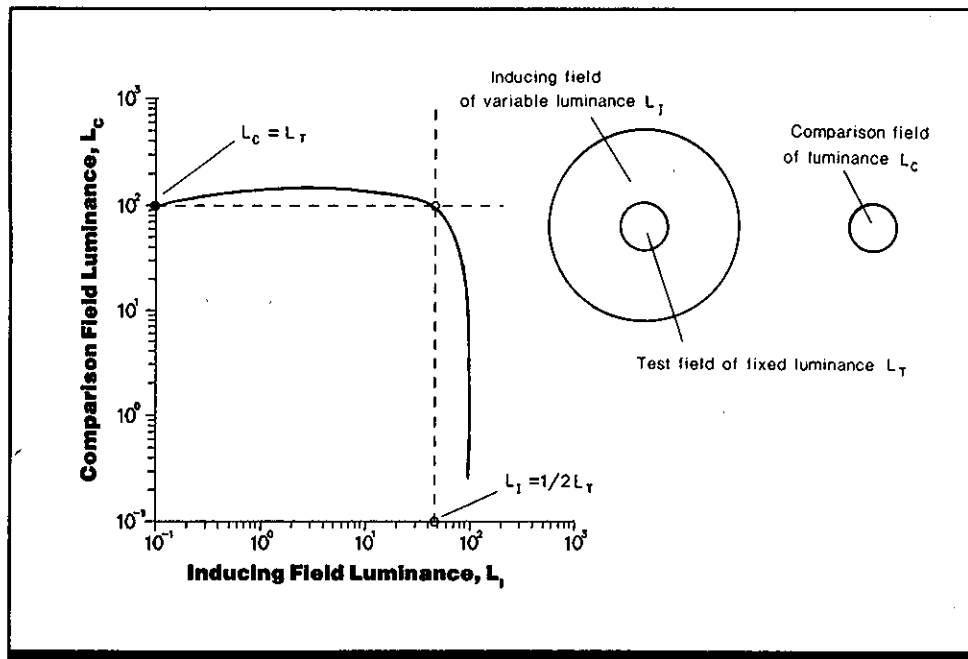

Figure 2. Typical change in the lightness of a constant-luminance achromatic test field (L_T), resulting from increasing luminance of an inducing field (L_I). Observers viewed the stimulus configuration shown on the right side of the figure, adjusting the luminance of a comparison field (L_C) (viewed against a black background) until it appeared to match the test field in lightness. The selection of luminance units for the figure is arbitrary (cd/m^2 , mL , fL , etc.); the induction effect is proportional. (From *Handbook of perception and human performance*, based on data from Ref. 6)

Methods

Test Conditions

- Test configuration as shown in Fig. 2; circular test and comparison fields, each 28 min arc of visual angle; test field and background inducing field presented to observer's right eye; comparison field against black background presented to left eye
- Central fixation point so fields

appeared side by side; 2.75 mm artificial pupils, viewing distance of 2.53 m

- Test field luminance held constant for each session, but seven luminances ranging from $0.1 \text{ cd}/\text{m}^2$ to $113 \text{ cd}/\text{m}^2$ (-1.45 to $1.55 \log \text{mL}$) were tested in different sessions
- Inducing field luminance varied in 7 to 12 progressively higher steps, from 0 (black) to about $140 \text{ cd}/\text{m}^2$ during each experimental session

- Observers dark-adapted for 20 min

Experimental Procedure

- Method of adjustment
- Independent variables: luminances of test and inducing fields
- Dependent variable: luminance of comparison field when it matched test field in lightness
- Observer's task: match lightness of test and comparison fields by

varying the luminance of the comparison field, as inducing field luminance increased

- Luminance measured with a Macbeth illuminometer, not corrected for differences in response of the observer's two eyes
- Seven experimental sessions per observer, 8 or 16 matches per observer per inducing field luminance
- 2 practiced observers

Experimental Results

- The lightness of a test field is enhanced when it is surrounded by an inducing field with comparatively low luminance.
- After inducing field luminance rises to about one-half that of the test field, the lightness of the test field drops rapidly.
- When the luminance of the inducing field exceeds test field luminance by about 30%, the matching field can no longer be adjusted to match the test field, even if the matching field's luminance is set to zero. In this case, the test field

appears "blacker than black," and a match can only be obtained by placing the matching field on a luminous background.

Variability

No information on variability was given, but averaged values from the two observers appear reasonably consistent. Several naive observers also were tested; results did not differ in any consistent way from those of the experienced observers.

Constraints

- This phenomenon is often called *simultaneous* brightness induction because it involves test and inducing fields that are presented simultaneously. It must be distinguished from induction effects that occur when the test and inducing

fields are separated in time, and which are usually discussed under the topic of adaptation.

- No simple physiological model is adequate to explain all brightness induction phenomena; e.g., the effect that changes in light at the edges of a field have on brightness (Ref. 3) is imperfectly understood.

Table 1. Factors influencing lightness and brightness induction.

Factor	Conditions	Effects	References
Test field location	Test field not centrally located in induction field	Induction effects are weaker	Ref. 7
Relative field sizes	Inducing and test fields of varied sizes	Larger inducing fields result in faster perception of brightness changes	Ref. 7
Distance between fields	Increasing separation between test and inducing fields, in the same plane	Induction rate and magnitude of effects diminish with increasing separation; major changes occur with small separations; further increases have little effect	Ref. 7
Inducing field configuration	Induction field not completely surrounding test field	Induction effects are much weaker	Ref. 7
	Two non-contiguous induction fields influencing the same test field	Induction effects are weaker than for a single induction field of the same total area	Ref. 7
Presentation duration	Test and induction fields observed very briefly	Flashes of light as brief as 0.2 msec result in induction effects	Ref. 7
Presentation sequence	Induction field light extinguished while the test field light remains on	Apparent brightness of test field still is affected by the luminance of the induction field before it was extinguished	Ref. 7
Relative distance of two test fields	Two identical test fields perceived to be against the same surround but at different distances from viewer	Estimates of test field lightness are less influenced by the lightness of the surround than if the test fields are perceived as being at the same distance	Refs. 3, 4
Apparent illumination of stimulus	Gray rectangular background containing black square and white square in illuminated room; half of field containing white square in shadow, half of field containing black square further illuminated by beam of projected light; illumination sources and shadowing device hidden from view	When observer is unaware of illumination on various parts of display, display appears as two coplanar adjacent black and white backgrounds, containing gray squares of slightly unequal lightness; when an additional black stimulus is placed to one side of the display so as to reveal to the observer the special illumination conditions, the display is correctly perceived as a gray background containing black and white squares	Refs. 3, 5

Key References

1. Brown, J. L., & Mueller, C. G. (1965). Brightness discrimination and brightness contrast. In C. H. Graham (Ed.), *Vision and visual perception* (pp. 229-240). New York: Wiley.

*2. Cornsweet, T. (1970). *Visual perception*. New York: Academic Press.

*3. Gilchrist, A. L. (1979). The perception of surface blacks and whites. *Scientific American*, 240, 112-124.

4. Gilchrist, A. L. (1980). When does perceived lightness depend on perceived spatial arrangement? *Perception & Psychophysics*, 28, 527-538.

5. Gilchrist, A. L., Delman, S., & Jacobsen, A. (1983). The classification and integration of edges as critical to the perceptance of reflectance and illumination. *Perception & Psychophysics*, 33, 425-436.

*6. Heinemann, E. G. (1955). Simultaneous brightness induction as a function of inducing- and test-field luminances. *Journal of Experimental Psychology*, 50, 89-96.

7. Heinemann, E. G. (1972). Simultaneous brightness induction. In D. Jameson & L. M. Hurvich (Eds.), *Handbook of Sensory Physiology: VIII/4. Visual Psychophysics* (pp. 146-169). New York: Springer Verlag.

8. Jameson, D., & Hurvich, L. M. (1964). Theory of brightness and color contrast in human vision. *Vision Research*, 4, 135-154.

Cross References

1.712 Brightness constancy;

1.714 Simultaneous lightness contrast: effect of perceptual organization;

1.715 Model of brightness contrast;

1.716 Mach bands;

1.717 Simultaneous color contrast;

1.721 Lightness scales;

Handbook of perception and human performance, Ch. 9, Sect. 3.1

Notes

1.714 Simultaneous Lightness Contrast: Effect of Perceptual Organization

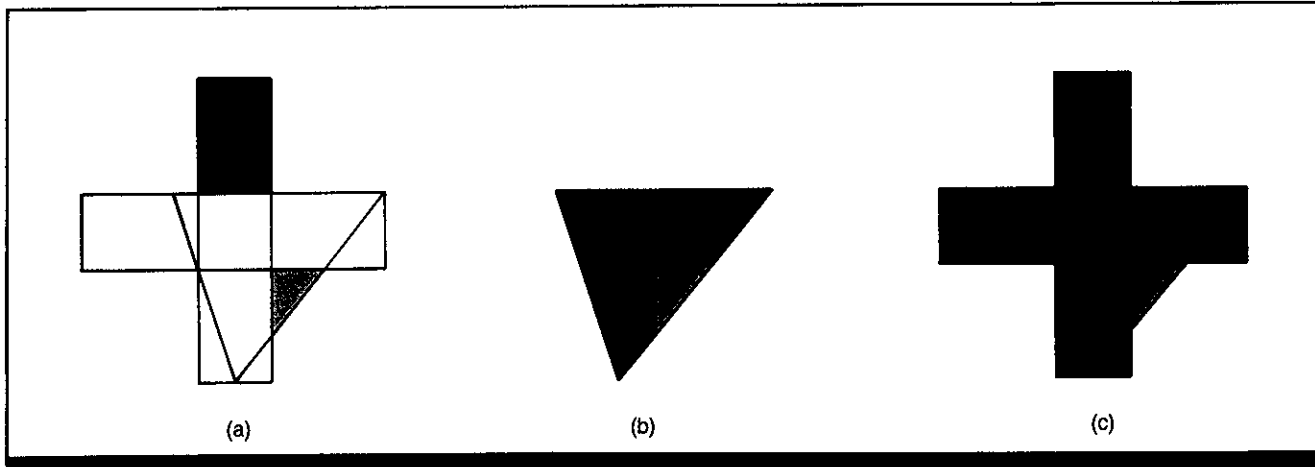

Figure 1. The Benary effect. The gray triangle on the larger black triangle (b) appears lighter than the one next to the black cross (c) despite the fact that the former is surrounded by less black than the latter. The drawing in (a) shows how the central figure is constructed from the cross. The “belongingness” of one gray triangle to the black triangle leads to greater contrast than the mere adjacency of the other gray triangle to the cross. (From Ref. 1)

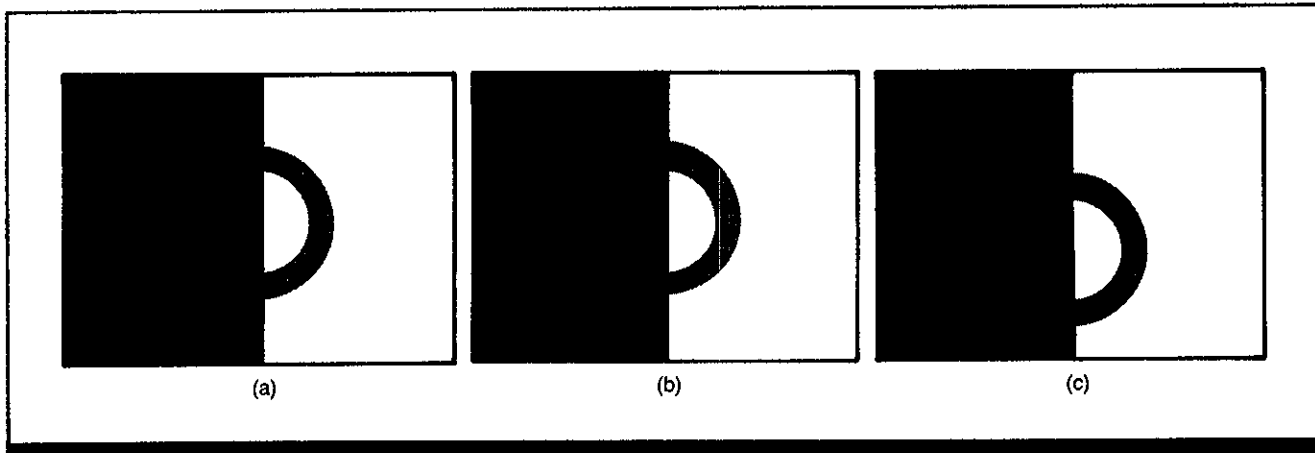

Figure 2. The Koffka-Benussi ring. (a) Each half of the gray ring should undergo contrast with the differing background reflectance values and thus appear different in lightness. That this does not occur suggests that the perceived unity of the ring opposes contrast. When thin vertical lines are placed on top of the central region of the ring (b) or the two halves of the ring are shifted (c), the contrast effect occurs. (From Ref. 6)

Key Terms

Lightness; lightness induction; perceptual organization; simultaneous brightness contrast

General Description

The *lightness* of an object or surface (its whiteness, grayness, or blackness) correlates primarily with its reflectance, i.e., the amount of incident illumination reflected from its surface. However, lightness is also influenced by the surroundings in which the object is viewed. For example, a gray square of given reflectance will appear lighter when it is viewed against a black background than when it is viewed

against a white background. This effect is an example of *lightness induction* and is known as *simultaneous lightness contrast* (CRef. 1.713).

The lightness of surfaces is also affected by the organization of the visual information. Surfaces which are perceived to belong together exhibit more lightness contrast than surfaces which are not perceived to belong together. For example, in Figs. 1b and 1c, the gray triangles have

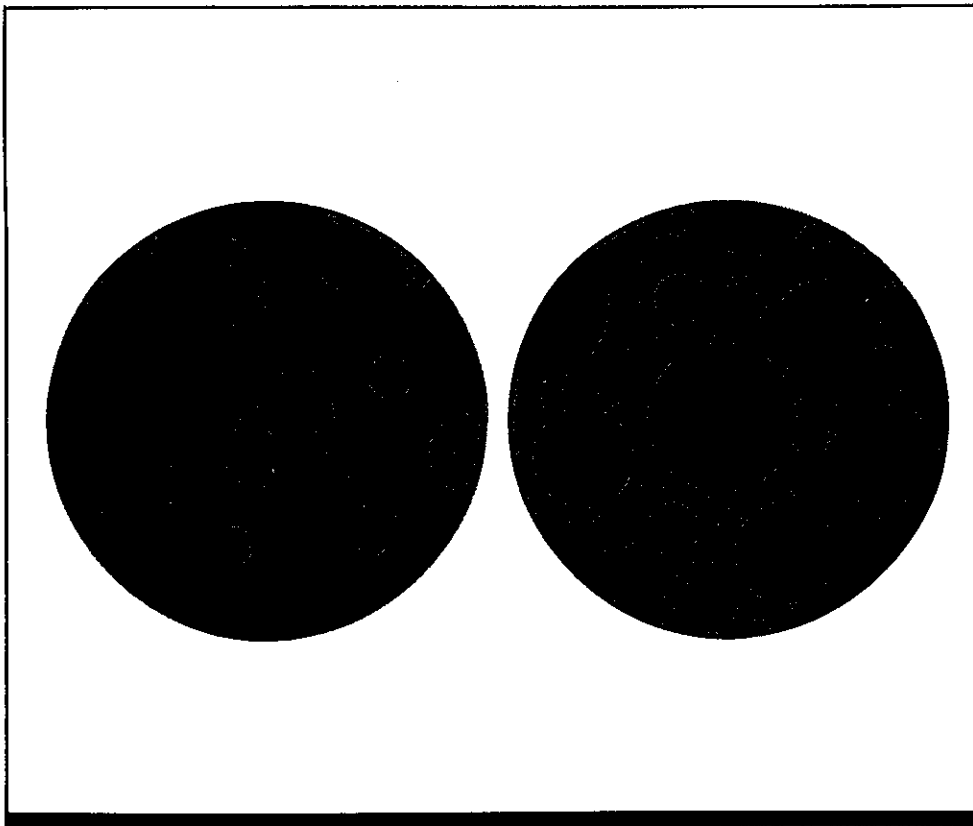

Figure 3. Differential contrast of figure and ground. Although the light gray regions in both circles are equal in area and lightness value, those perceived as figures (left) appear lighter than the region seen as ground (right). A similar effect occurs for the dark gray regions; those appearing as figures on the right appear darker than the ground on the left. (From Ref. 4)

equal reflectances and are bounded for equal extents by black; however, the gray triangle next to the cross shows less lightness contrast (appears darker) than the gray triangle that is perceived as part of a larger black triangle.

Effects of lightness contrast extend throughout a surface and are limited to the perceived surface (Fig. 2). The gray ring is unaffected by conflicting contrast information until it is broken into two half rings, each of which exhibits the expected lightness contrast effects (Ref. 5).

A surface perceived as figure contrasts with the background more than the background contrasts with the figure (Fig. 3, Ref. 4). For two lighter gray surfaces of equal re-

flectance intermixed with darker gray surfaces, the lighter gray figure appears lighter than the lighter gray background.

A surface does not exhibit lightness contrast with retinally adjacent surfaces if the surface is not coplanar with the background surface (i.e., if it is at a different distance than the background) (Ref. 3). In general, spatial position is as important in lightness contrast as are illumination and reflectance; this is consistent with the role played by the spatial position of a light source in determining illumination in real world scenes.

Applications

Selection and specification of reflectance, luminance, and illumination levels for areas and objects and for their backgrounds, when constancy of lightness is desired (as in light-

ing, painting, or otherwise treating a surface on which brightness homogeneity may be important) or when specific differences in lightness are necessary (as for lightness coding in visual displays).

Key References

1. Benary, W. (1924). Beobachtung zu einem Experiment über Helligkeitskontrast. *Psychologische Forschung*, 4, 131.
2. Cornsweet, T. N. (1970). *Visual perception*. New York: Academic Press.
3. Gilchrist, A. (1980). When does perceived lightness depend on perceived spatial arrangement? *Perception & Psychophysics*, 28, 527-538.
4. Metzger, W. (1953). *Gesetze des Sehens*. Frankfurt, W. Germany: Waldemar Kramer.
5. Rock, I. (1983). *The logic of perception*. Cambridge, MA: MIT Press.
6. Rock, I. (1986). The description and analysis of object and event perception. In K. R. Boff, L. Kaufman, & J. P. Thomas (Eds.), *Handbook of perception and human performance: Vol. II. Cognitive processes and performance*. New York: Wiley.

Cross References

- 1.712 Brightness constancy;
- 1.713 Brightness induction;
- 1.715 Model of brightness contrast

1.715 Model of Brightness Contrast

Key Terms

Achromatic induction; brightness; brightness constancy; brightness contrast; brightness induction; brightness matching; color appearance; lightness; lightness constancy; lightness contrast; lightness induction; lightness matching; luminance; spatial contrast

General Description

An area or object with fixed luminance or reflectance generally appears brighter or lighter against a dim or dark background than against a brighter or whiter background. For example, a gray square of given reflectance will appear a slightly darker gray when viewed against a white background than when viewed against a black background. This effect is known as *simultaneous brightness* or *lightness contrast* and is an example of *induction* (CRef. 1.713). (The effect is most frequently discussed in terms of brightness because the experimental stimuli usually appear self-luminous.)

A quantitative model presented in Ref. 4 has been successful in predicting the brightness of a test stimulus from its luminance and the luminance of the area surrounding it. According to this model:

$$R_f = \frac{c(S_f^n - kS_s^n)}{1 - k^2} \tag{1}$$

where S_f is the luminance of the test stimulus (whose image falls on the focal area of the retina), S_s is the luminance of the surround or background of the test stimulus (known as the inducing field), R_f is the resulting visual response to the test stimulus (i.e., its brightness), n is an empirically determined exponent (for an achromatic stimulus on a black background, $n = 1/3$), k is an empirically determined induction-strength factor; (for small test stimuli subtending up to 30 min arc of visual angle, $k \approx 0.1$ to 0.2 ; for larger stimuli up to 12 deg, $k \approx 0.4$), and c is a constant scaling factor of appropriate magnitude and dimension to account for the measurement unit used to specify the stimulus. (At the moment, there are no agreed upon units for brightness, so the value of c is arbitrary and can, for simplicity, be assumed = 1. The authors incorporated it into the model only for the sake of completeness.)

For example, if an achromatic test stimulus has luminance of 10 luminance units, the background is black ($S_s = 0$), the induction factor k is known to be 0.2, and the scaling constant c is taken to be 1, then stimulus brightness is predicted to be

$$R_f = \frac{(10)^{1/3}}{1 - (0.2)^2} = 10^{.35} = 2.24 .$$

If the same test stimulus is imbedded in a background with luminance of 200 units and n remains = 1/3, brightness drops:

$$R_f = \frac{(10)^{1/3} - 0.2(200)^{1/3}}{1 - (0.2)^2} = 10^{.01} = 1.03$$

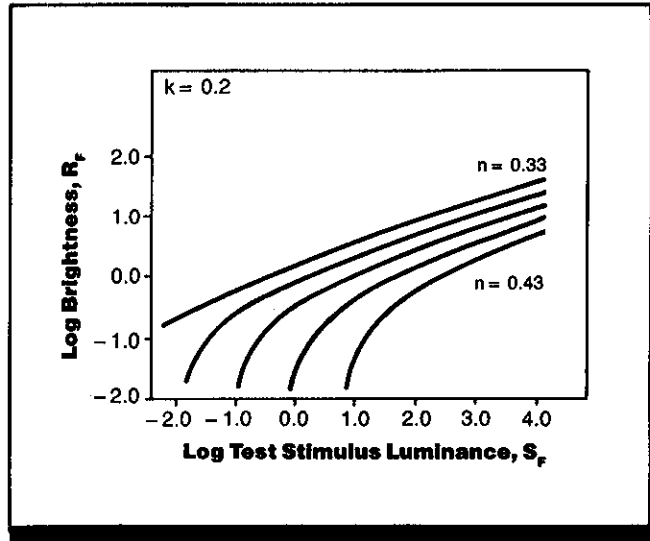

Figure 1. Examples of the relationship between brightness and luminance as predicted by the model. The five curves, from top to bottom, represent five levels of background (inducing field) luminance, ranging from black (curve whose linear portion has slope $n = 0.33$) to very bright (curve for which $n = 0.43$). The induction factor, k , is assumed = 0.2 for these curves. Selection of luminance units is arbitrary (cd/m², mL, fL, etc.). (From Ref. 4)

Figure 1 illustrates typical curves generated by this model. The top curve represents the test stimulus brightness-to-luminance relationship for a black background. The remaining four curves represent (from top to bottom) increasing levels of background luminance. The brightness of the test stimulus increases as its luminance increases and/or as the luminance of the background decreases. The effect of the background is proportionally greater at lower test stimulus luminances.

The model rests on the following propositions and assumptions:

1. Net visual response, R_f , in the focal area f (containing the image of the test stimulus) is proportional to the luminance of the test area raised to a power n , plus an induced response, I_f , in the same focal area, i.e;

$$R_f = cS_f^n + I_f. \tag{2}$$

2. Net visual response R_s in the surrounding area s (containing the image of the background or surround of the test stimulus) is proportional to the luminance of the background raised to the same power n , plus an induced response, I_s in the background; i.e.,

$$R_s = cS_s^n + I_s. \tag{3}$$

3. The induced responses I_f and I_s are assumed to be of opposite sign to visual responses R_s and R_f , but otherwise proportional to them and thus

$$I_f = -kR_s \text{ and } I_s = -kR_f. \tag{4}$$

Combining the above equations yields

$$R_f = cS_f^n - kR_s \text{ and } R_s = cS_s^n - kR_f$$

or the single expression in Eq. 1.

In a brightness matching experiment, a comparison field f' with its own background s' produces visual response $R_{f'}$. It is placed near the test stimulus f and its background s which produces the response R_f . A brightness match is obtained when net visual responses for the test and comparison

stimuli are equal, that is, when $R_f = R_{f'}$. For any such case, the induction factor k may be determined empirically from the equation

$$k = \frac{S_f^n - S_{f'}^n}{S_s^n - S_{s'}^n} \tag{5}$$

which can be derived from Eqs. 2-4 and the assumption $R_f = R_{f'}$.

Applications

Predicting whether two stimuli that differ in luminance and lie on backgrounds that also differ in luminance will match in brightness or lightness and, if they do not match, predicting the size of the difference.

Empirical Validation

The model has been applied with reasonable success to data from several experiments, including studies of brightness as a function of background area and luminance (Refs. 1, 2), brightness as a function of distance between test stimulus and inducing area (Ref. 4), and brightness with non-foveal viewing (Ref. 3).

Constraints

- With multiple inducing fields, the total effect is predictable but more complicated than a simple average of the induction effects for single inducing fields.
- Many factors influence induction effects and can yield unexpected or unpredictable results.
- The induction factor constant k is affected by the location of the test stimulus in the visual field (as well as by test

stimulus size); k may be as high as 0.6 for presentations 5 deg from the fovea.

- This model has not been applied to stimulus configurations that include special illumination conditions (shadowing and spotlighting) of which the observer is unaware (e.g., Ref. 3), and may not be appropriate for those visual conditions.

Key References

1. Diamond, A. L. (1953). Foveal simultaneous brightness contrast as a function of inducing- and test-field luminances. *Journal of Experimental Psychology*, 45, 305-314.
 2. Diamond, A. L. (1955). Foveal

simultaneous contrast as a function of inducing field area. *Journal of Experimental Psychology*, 50, 144-152.

3. Gilchrist, A. L., Delman, S., & Jacobsen, A. (1983). The classifi-

cation and integration of edges as critical to the perception of reflectance and illumination. *Perception & Psychophysics*, 33, 425-436.

*4. Jameson, D., & Hurvich, L. M. (1964). Theory of brightness and color contrast in human vision. *Vision Research*, 4, 135-154.

5. Leibowitz, H., Mote, F. A., & Thurlow, W. R. (1953). Simultaneous contrast as a function of separation between test and inducing fields. *Journal of Experimental Psychology*, 46, 453-456.

Cross References

1.712 Brightness constancy;
 1.713 Brightness induction;
 1.721 Lightness scales;
Handbook of perception and human performance, Ch. 9, Sect. 3.5

1.716 Mach Bands

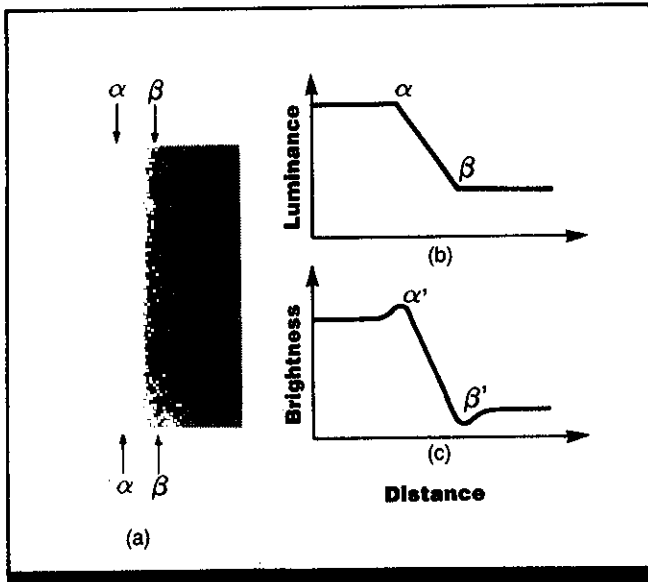

Figure 1. In pattern (a) the luminance is constant in the vertical direction and varies horizontally according to diagram (b). A bright Mach band appears at α and a dark band at β , so that the subjective brightness varies approximately as shown in (c). (From Ref. 3)

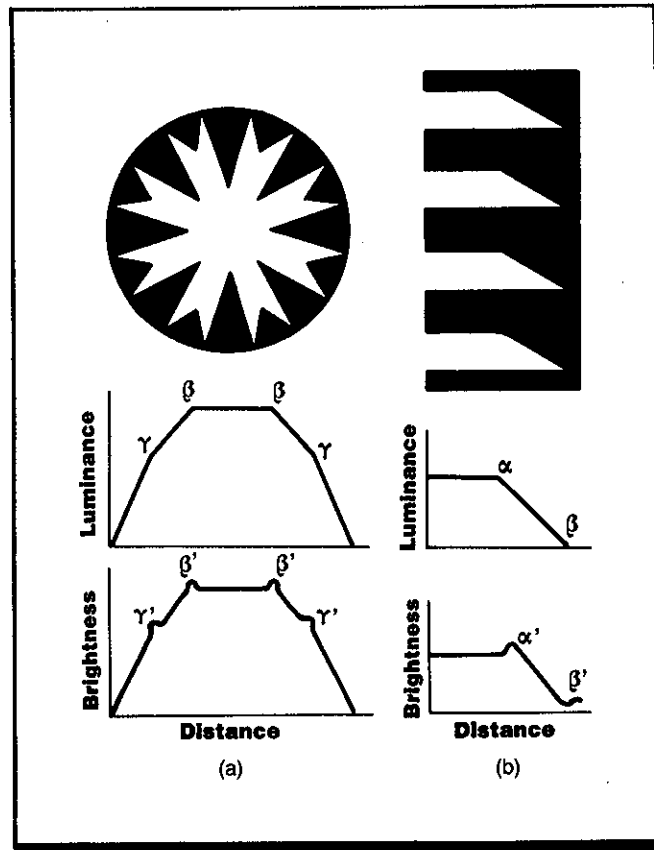

Figure 2. Patterns used with rotating discs (a) or cylinders (b) to produce Mach bands. The Mach bands are perceived at points where the luminance curves bend [points β' and γ' of the disc diameter in (a) and points α' and β' of the direction parallel to the axis of rotation of the cylinder in (b)]. (From Ref. 3)

Key Terms

Achromatic induction; border effects; color appearance; Mach bands; simultaneous color contrast

General Description

Mach bands are bright or dark bands that appear near a boundary between adjacent, illuminated light and dark regions in a visual field. Because the bright band is in the light region and the dark band is in the dark region (Fig. 1), the phenomenon functions as an edge enhancement. The effect occurs even though the physical distribution of light shows no changes in luminance that correspond to changes in perceived brightness.

Figure 2 shows the distribution of luminance and the perceived brightness for two patterns that generate Mach bands when they are rotated at an appropriate speed. The effect is influenced by several variables:

- Width of the bright band decreases if either the highest luminance or the steepness of the luminance gradient from α to β (i.e., the slope from dark to light) increases. The

dark band at β' (in the brightness plot in Fig. 2b) seems to be less dependent on the steepness of the gradient.

- Difference in brightness between the Mach bands and the adjacent areas increases as the angular width of the area from α to β decreases for patterns containing a linear gradient (e.g., the pattern in Fig. 2b).

- The threshold for perception of Mach bands depends on exposure duration. The bands are seen with stimulus durations as brief as 1-2 msec, provided the luminance gradient is very steep. As exposure increases to ~ 50 msec, the critical slope of the gradient decreases linearly.

- The appearance of Mach bands is uncertain if the border between regions of high and low illumination is maximally distinct, that is, if the α - β slope approaches infinity; likewise, as the steepness of the slope approaches zero, Mach bands disappear.

• The critical slope of gradient pattern (i.e., the smallest slope, m , at which Mach bands can be seen) varies with the local luminance level (luminance in the region of the edge). (For a linear gradient, the slope m is defined as the luminance difference between two points of the gradient divided by the angular separation of the points.) When $L > 3 \text{ cd/m}^2$ (50 trolands), m is proportional to L and their ratio is a constant; for $L < 3 \text{ cd/m}^2$, m/L increases as L decreases. At mesopic (low) or scotopic (very low) luminance levels, Mach bands are not visible even with a very steep gradient.

Although the examples in Fig. 2 are for rotating stimuli, the phenomenon also occurs with a simple ramp gradient (Fig. 1) and can interfere with perception (Ref. 3). If a target like a small spot or line appears near a region of abrupt change, the luminance threshold for its perception will increase; as the target is positioned away from the region of change, the luminance level required for perception of the

target decreases. Perception of the target is made more difficult with sharp gradients, high luminance contrast, and longer exposure times (i.e., 10 msec).

Some researchers have examined whether Mach bands are produced by a chromaticity gradient (e.g., red to green with luminance held constant), but there have been few positive results (see Repeatability section).

Repeatability/Comparison with Other Studies

Mach bands for achromatic stimuli are very well documented. There is controversy about the appearance of Mach bands for chromatic stimuli. Ref. 2 consistently found Mach bands for chromatic step gradients, but results were inconsistent for continuous gradients. Most previous work that failed to find Mach bands with chromatic stimuli used continuous gradients.

Constraints

- There are large individual differences in the perception of Mach bands.
- Results vary according to the experimental method used to measure Mach bands.

- The position of the bands depends on level of illumination, and may also vary from observer to observer.
- The level of light adaptation in the region of the retina on which the luminance gradient falls as well as stimulus exposure duration affects threshold for appearance of Mach bands.

Key References

1. Cornsweet, T. N. (1970). *Visual perception*. New York: Academic Press.

2. Daw, N. W. (1964). Visual response to gradients of varying col-

our and equal luminance. *Nature*, 203, 215-216.

*3. Fiorentini, A. (1972). Mach band phenomena. In D. Jameson & L. M. Hurvich (Eds.), *Visual psy-*

chophysics. New York: Springer-Verlag.

4. Ratliff, F. (1965). *Mach bands: Quantitative studies on neural networks in the retina*. San Francisco: Holden-Day.

5. Van der Horst, G. J. C., & Bouman, M. A. (1967). On searching for "Mach band type" phenomena in color vision. *Vision Research*, 7, 1027-1029.

Cross References

1.713 Brightness induction;

1.715 Model of brightness contrast;

1.717 Simultaneous color contrast

1.717 Simultaneous Color Contrast

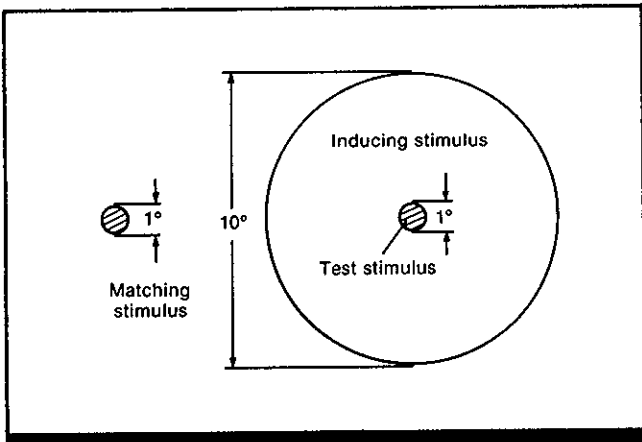

Figure 1. Example of a configuration commonly used to study color contrast effects. The colors of both test stimulus and inducing field are fixed; the observer adjusts the color of the matching stimulus (with a dark surround) until it completely matches the test stimulus. (Note: a different test configuration was used to obtain the data in Fig. 2; see text.) (From *Handbook of perception and human performance*)

Key Terms

Chromatic induction; color appearance; simultaneous color contrast

General Description

The color of a target area depends partly on contrast effects induced by the color of the surrounding area. In simple configurations with a small test area placed on a larger surround (Fig. 1), the color of the target tends to be shifted away from the color of the inducing stimulus (the background).

For example, a grey spot takes on a reddish hue when placed on a green surround and a greenish hue when placed on a red surround. In a more complex configuration in which colored test bars are altered with wider inducing bars of a different color, the hue of the test bars is also shifted away from the hue of the inducing bars (Fig. 2).

Applications

Selection and specification of desired hues for colored lights, painted surfaces, and colored display formats.

Methods

Test Conditions

- Two rectangular fields, a test field and a matching (variable) field, each 1.5 × 2.0 deg of visual angle and separated by 0.5 deg, produced by a two-channel Max-

- wellian viewing system; achromatizing lens in front of the test field; test field presented to right eye and matching field presented to left eye
- Test field made of five thin stripes (6 min wide) between wider (18 min) inducing stripes
- 15 test colors presented alone

and with red, yellow, green, blue, and white inducing colors

Experimental Procedure

- Method of adjustment
- Independent variables: presence versus absence of inducing field, color of inducing field, color of test field

- Dependent variable: chromaticity coordinates of match to test field
- Observer's task: adjust color of variable field to match that of test field
- 2 observers, 1 knowledgeable and practiced and 1 naive

Experimental Results

- For all test stimuli, color appearance of the test bars is shifted away from the color of the inducing field (left panel in Fig. 1).
- Patterns of shift in Fig. 2 are not consistent with any one-process model (either a pure receptor model or a pure opponent-channel model). Data are fairly well fit by either of two

models that assume induction effects at both receptor and opponent-channel levels. Predictions from one of the models are shown on the right side of Fig. 2. Especially noteworthy is the good agreement between the predictions of the model and the observed data for the blue inducing stimulus (second panel from bottom), which has a strongly curved chromaticity-vector pattern.

Variability

Open circles in lower left corners of data plots in Fig. 1 are two standard deviations in diameter, estimated from all matches for a given inducing color. Data from observers are very similar overall.

Repeatability/Comparison with Other Studies

General pattern of chromaticity shifts obtained with the achromatizing lens agrees with prior studies. Without the lens, axial chromatic aberration of the eye produces a distortion of matching judgments, especially for the blue inducing field.

Constraints

- Magnitude and direction of chromaticity shifts are likely to vary with display size and shape.
- Quantitative prediction of chromaticity shifts with complex displays has not been achieved.
- Effects of chromatic aberration on color appearance are not well understood.
- Color appearance is influenced by a number of target characteristics and viewing conditions (CRef. 1.707).

Key References

1. Chevreul, M. E. (1967). *The principles of harmony and contrast of colors*. New York: Van Nostrand. (Originally published in 1839).

2. Hurvich, L. M. (1981). *Color vision*. Sunderland, MA: Sinauer Associates.

*3. Ware, C., & Cowan, W. B. (1982). Changes in perceived color due to chromatic interactions. *Vision Research*, 22, 1352-1362.

Cross References

1.707 Factors influencing color appearance;

1.713 Brightness induction;

1.718 Color assimilation;

Handbook of perception and human performance, Ch. 9, Sects. 3.2, 3.3

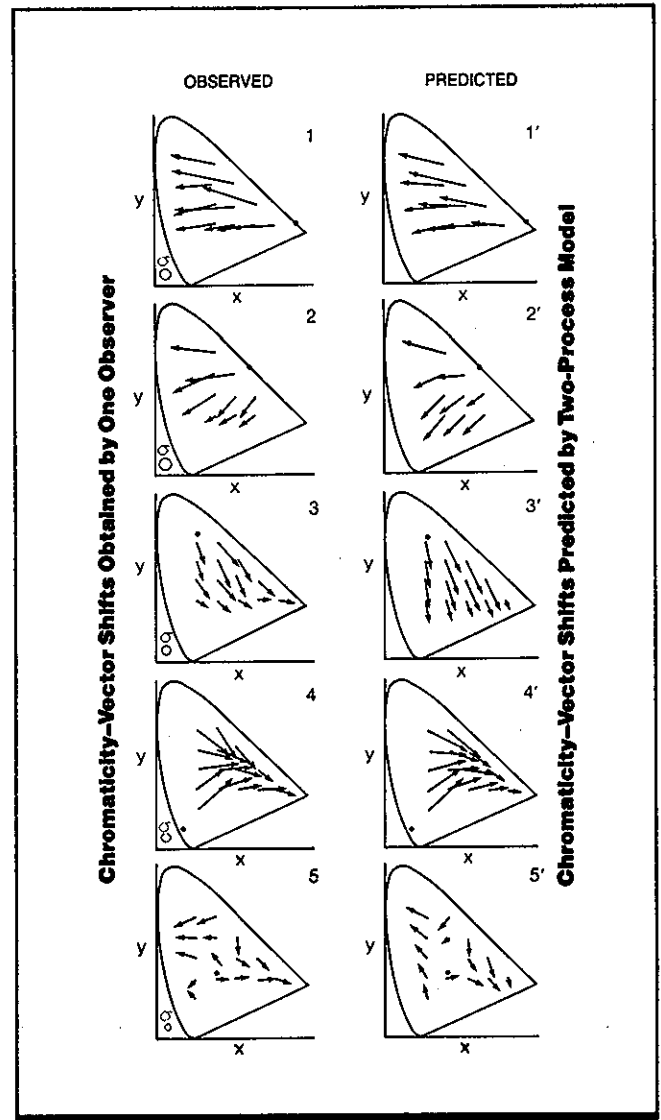

Figure 2. Chromatic induction. Observed and predicted values showing that the chromaticity of a test stimulus is shifted away from that of an inducing field. Results are plotted in the CIE 1931 (x, y) chromaticity diagram as chromaticity-vector shifts. The tail of the vector is the match obtained in the absence of the inducing field, and the head of the vector is the match obtained in the presence of the inducing field. Diagrams, from top to bottom, show chromaticity shifts induced by red, yellow, green, blue, and white inducing fields for 15 test stimuli. Chromaticity of the inducing field is indicated by the filled dot in each diagram. Data from one observer are shown on the left; the right side shows predictions made by a color-vision model that involves both receptor channels and opponent-color channels. (From Ref. 3)

1.718 Color Assimilation

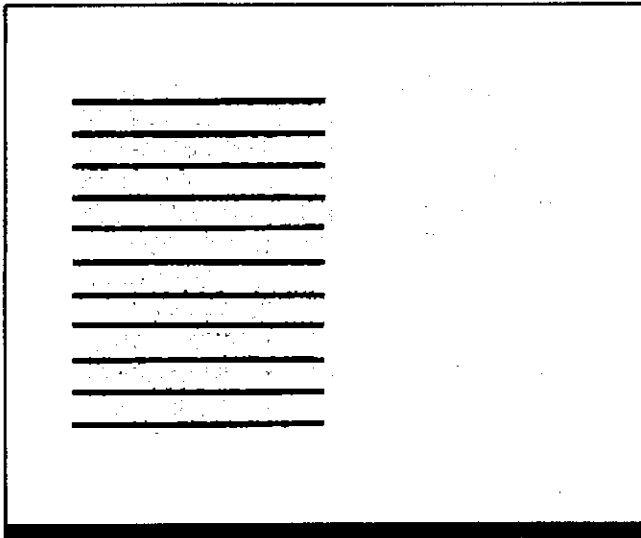

Figure 1. Configuration for demonstrating color assimilation; the uniform gray background tends to take on the color of the stripes that overlay it. If the black and white stripes are replaced by blue and yellow stripes, respectively, the grey on the left would appear bluish and the grey on the right would appear yellowish.

Key Terms

Bezold spreading effect; chromatic induction; color appearance; color assimilation; color spreading

General Description

With certain complex visual stimuli, such as patterns of stripes on a background of uniform color, the color of the background shifts toward the color of the stripes; this effect is known as *color assimilation*. Consider, for example, a uniform gray rectangular background with thin blue stripes on the left half and thin yellow stripes on the right half. Color assimilation leads to a bluish appearance for the gray in the left half and a yellowish appearance for the gray in the right half (i.e., reduced contrast between the colors). The effects of color assimilation are therefore opposite to that of simultaneous color contrast (CRef 1.717), which would result in a yellowish appearance in the gray on the left and a bluish appearance in the gray on the right (i.e. contrast enhancement). Color assimilation is also distinct from color blending, because, unlike blending, color assimilation does not involve any loss of spatial resolution. The pattern is

clearly visible despite the apparent shift in background color.

Descriptively, color assimilation represents a weighted averaging of the color of the background with that of the superimposed pattern. However, actual visual mechanisms that produce the phenomenon are not yet known.

There appears to be a continuum from color assimilation (reduced color contrast) to regular color contrast (enhanced color contrast), depending on such factors as the reflectance of the background, the size of pattern elements (e.g., the thickness of stripes), and the separation between pattern elements (e.g., distance between stripes). In general, though, color assimilation occurs with relatively fine pattern elements enclosing small areas and is replaced by color contrast as the pattern elements become thicker and more widely separated.

Applications

Selection and specification of desired hues for colored lights, painted surfaces, and colored display formats.

Constraints

- Color appearance is influenced by many factors, including target characteristics and viewing conditions (CRef. 1.707).
-

Key References

- | | | |
|--|---|--|
| 1. Burnham, R. W., Hanes, R. M., & Bartleson, C. J. (1963). <i>Color: A guide to basic facts and concepts</i> . New York: Wiley. | 2. Evans, R. M. (1948). <i>An introduction to color</i> . New York: Wiley. | 4. Hurvich, L. M. (1981). <i>Color vision</i> (pp. 175-176, plate 13-3). Sunderland, MA: Sinauer Associates. |
| | 3. Helson, H. (1963). Studies of anomalous contrast and assimilation. <i>Journal of the Optical Society of America</i> , 53, 179-184. | |
-

Cross References

- 1.707 Factors influencing color appearance;
- 1.713 Brightness induction;
- 1.717 Simultaneous color contrast

1.719 Phantom Colors

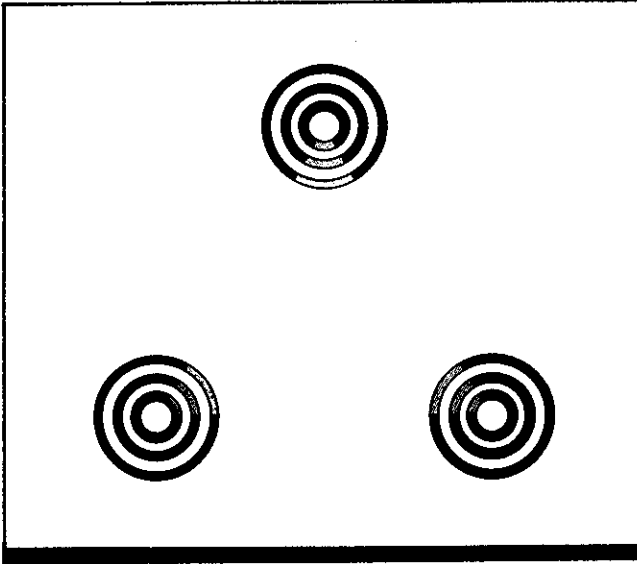

Figure 1. A configuration that produces an illusory colored triangle (Kanizsa's triangle). For example, if the shaded segments are colored red, the triangle will appear pinkish. (From *Handbook of perception and human performance*)

Key Terms

Benham's disk; color appearance; Fechner's colors; illusory color; phantom color; subjective color

General Description

Phantom or illusory colors refer to the perception of one or more hues in an area of a display that is actually **achromatic** (or contains only hues of a different **chromaticity** than the hue seen). Unlike afterimages, which appear after the observer's gaze is shifted or the display is removed, phantom colors appear during fixation of the display. Two general classes of phantom-color displays can be identified. One class includes the perception of color in a figure with illusory contours (Fig. 1) and can be thought of as a special case of color **assimilation** (CRef. 1.718) in which assimilation spreads within contours that are not physically present. A second class includes the perception of color within certain black and white displays. The critical element for phantom colors in the second case is the alternation of black and white elements. The alternation can be produced by a slow scan of a stationary display (Fig. 2) or by a stationary gaze at moving or pulsing displays (Fig. 3). Figure 3 depicts Benham's disc (Ref. 1), which produces desaturated hues between the curved line segments when the disk is rotated at 5-15 Hz. Clockwise rotation produces red in the inner rings,

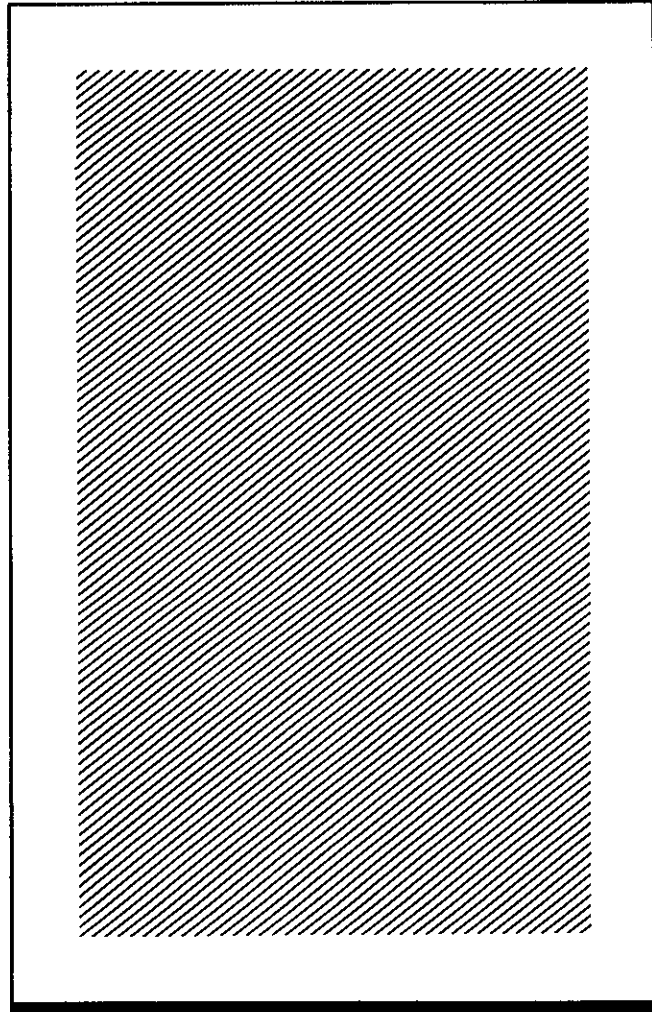

Figure 2. A stationary grid display which induces pastel-like phantom colors if the gaze is allowed to wander slowly over the pattern. (From Ref. 3)

green in the middle rings, and blue in the outer rings; counterclockwise rotation reverses this ordering.

Explanations for phantom colors have not been completely worked out. To account for the first class of phantom-color effects requires an adequate explanation of illusory contours, which are currently a source of controversy (Ref. 2). It is widely believed that differences in the temporal properties of excitation and inhibition among retinal neurons are involved in the second type of phantom-color effect (Ref. 4).

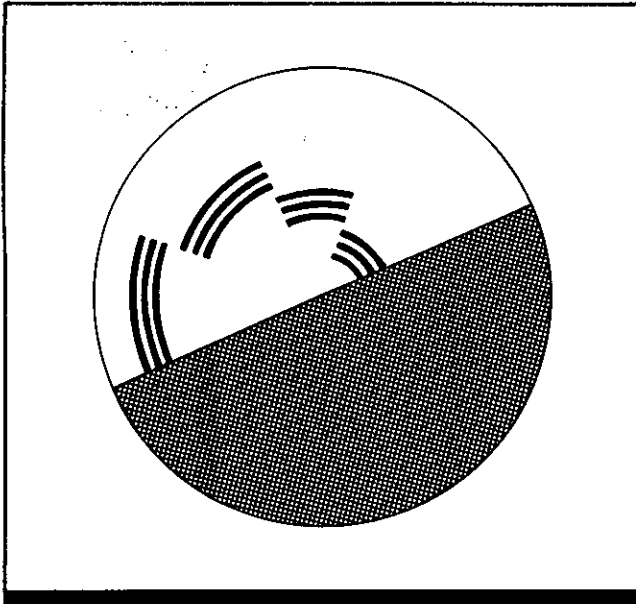

Figure 3. A depiction of Benham's disk. If the pattern is rotated about the center at 5-15 Hz, desaturated colors appear between the curved line segments. Clockwise rotation induces red in the inner segments, green in the middle segments, and blue in the outer segments; counterclockwise rotation induces the reverse ordering of the colors. (From *Handbook of perception and human performance*)

Applications

Pulsing monochromatic displays, such as video screens, oscilloscopes, and radar screens, where phantom colors may be produced.

Constraints

- The display characteristics that produce phantom colors have not yet been specified precisely.

Key References

- | | | |
|--|---|---|
| <p>1. Benham, C. E. (1894). Notes. <i>Nature</i>, 51, 113-114.</p> <p>2. Frisby, J. P. (1980). <i>Seeing: Illusion, brain and mind</i>. New York: Oxford University Press.</p> | <p>3. Hurvich, L. M. (1981). <i>Color vision</i> (pp. 175-176, plate 13-3). Sunderland, MA: Sinauer Associates.</p> <p>4. Jameson, D. L. (1972). Theoretical issues of color vision. In D. Jameson, & L. M. Hurvick (Eds.),</p> | <p><i>Visual psychophysics</i>. New York: Springer-Verlag.</p> <p>5. Ware, C. (1980). Coloured illusory triangles due to assimilation. <i>Perception</i>, 9, 103-107.</p> |
|--|---|---|

Cross References

- | | |
|--|---|
| <p>1.717 Simultaneous color contrast;</p> <p>1.718 Color assimilation;</p> | <p>6.314 Subjective or illusory contours;</p> <p><i>Handbook of perception and human performance</i>, Ch. 9, Sect. 3.3, 4.3</p> |
|--|---|

1.720 Brightness Scales

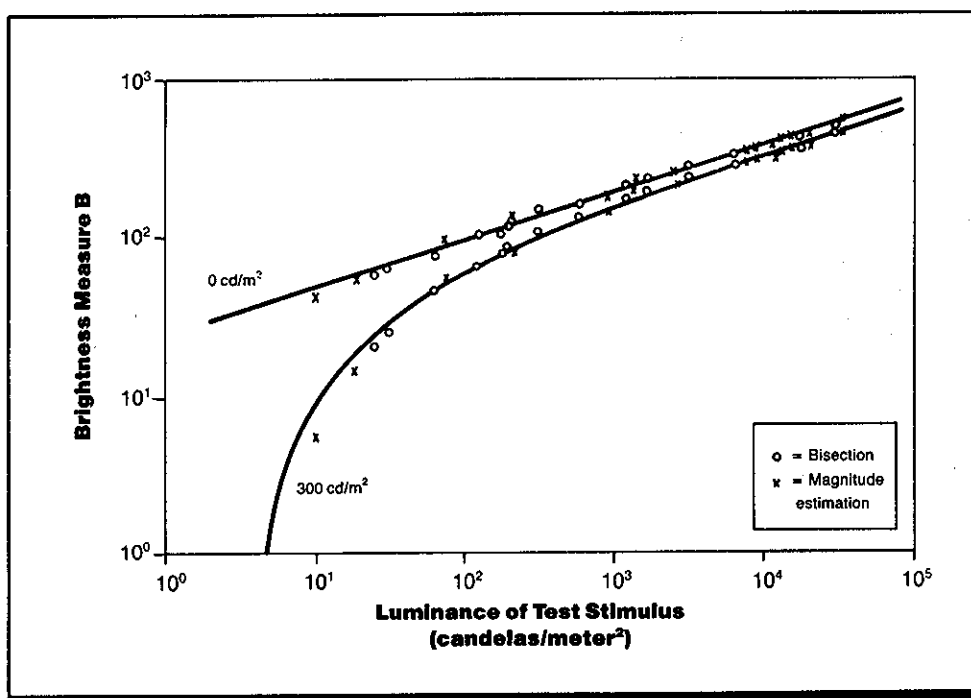

Figure 1. Perceived brightness of a test target as a function of target luminance for two surround luminance levels. Data were collected using a bisection task (circles) and a magnitude estimation task (crosses). (From *Handbook of perception and human performance* based on data from Ref. 3)

Key Terms

Brightness; brightness scale; color appearance; luminance; Stevens' power law

General Description

Brightness is a psychological property of a visual target related to the luminous intensity of the light emitted from that target. The brightness of a target can range from very bright (dazzling or brilliant) to very dim or dark. (Brightness is to be distinguished from *lightness*, which is the extent to which a surface appears to emit light in proportion to that emitted by a similarly illuminated surface which appears white) (CRef. 1.706). Brightness is not a linear function of luminance; rather, brightness is related to luminance by a power function. For a target with a dark surround, the brightness of the target can be calculated as:

$$B = aL^N; \quad (1)$$

and for a bright surround,

$$B = aL^N - B_0, \quad (2)$$

where B is the estimated brightness under a given luminance level L and a given set of viewing conditions. The exponent N is a constant equal to ~ 0.33 (Ref. 3 reports a value of 0.31 ± 0.03 for a variety of observers and suprathreshold viewing conditions). The values of a and B_0 are empirically determined and influenced by factors such as surround luminance and stimulus size; they include an arbitrary scaling factor. The term B_0 has been interpreted as a response correction that allows for neural induction when the test stimulus is viewed against a background of nonzero luminance (Ref. 6).

Brightness depends primarily on the luminance of the target, but is also influenced by the luminance of the target surround and, in some cases, the size of the target.

Methods

Test Conditions

- Bisection task: two reference stimuli and one test target, each 2-deg diameter, with 5.7-deg separation between them; homogeneous 180-deg surround of constant luminance equal to 0.0 or 300 cd/m²; luminances of reference stimuli ranged from 0 to 3×10^4 cd/m²; all

stimuli presented continuously until observer completed response

- Magnitude estimation task: same as for bisection task except only two stimuli (standard stimulus and test target) presented

Experimental Procedure

- Independent variables: brightnesses of two reference stimuli

(bisection task), brightness of standard stimulus (magnitude estimation task)

- Dependent variable: for bisection task, luminance at which brightness of test target appeared midway between brightnesses of reference stimuli; for magnitude estimation task, judged relative brightness of test target

- Observer's task: for bisection task, adjust brightness of test target until midway in brightness between two reference stimuli; for magnitude estimation task, estimate brightness ratio between test target and standard stimulus
- Number of observers not reported

Experimental Results

- For a dark surround, target brightness increases as a power function of target luminance and can be described by Eq. 1 except near threshold, with $N = 0.31$ (upper solid line in Fig. 1).
- With a bright surround, results follow Eq. 2, i.e., Eq. 1 with a constant term B_0 subtracted (lower solid line in Fig. 1).
- There is a reliable linear relationship between brightness scales obtained by a bisection task and by a magnitude estimation task.
- The brightness measure B decreases sharply when the lu-

minance of the target is lower than the luminance of the surround (bottom curve of Fig. 1). This decrease is due to induction effects (CRef. 1.713).

- The zero point ("black level," or brightness threshold) used as a natural origin for the brightness scale was determined empirically in a separate experiment. Brightness threshold increases as the luminance of the target surround increases; brightness threshold increases as target size decreases.
- The size of the test target significantly affects the perception of brightness only for small targets that have low luminance levels.

Variability

No information on variability was given.

Constraints

- Observer attitude exerts negligible effects on the results obtained.
- The power law function with $N = 0.31$ does not hold for targets with close-to-threshold luminance.

- Brightness is influenced by the observer's state of light adaptation, by the background against which the target is viewed, and possibly by the age of the observer.

Key References

1. Aiba, T. S., & Stevens, S. S. (1964). Relation of brightness and luminance under light- and dark-adaptation. *Vision Research*, 4, 391-401.
2. Bartelson, C. J., & Breneman, E. J. (1967). Brightness reproduction in the photographic process. *Photographic Science and Engineering*, 11, 254-262.

*3. Bodman, H. W., Hauber, P., & Marsden, A. M. (1980). A unified relationship between brightness and luminance. In *Proceedings of the 19th Session of the Commission Internationale de l'Eclairage (CIE), Tokyo, 1979*. Tokyo: CIE.

4. Eriksen, C. W., Hamlin, R. M., & Breitmeyer, R. G. (1970). Temporal factors in visual perception as

related to aging. *Perception & Psychophysics*, 7, 354-356.

5. Jameson, D. (1970). Brightness scales and their interpretation. In M. Richter (Ed.), *Color 69*. Göttingen: Musterschmidt Verlag.

6. Jameson, D., & Hurvich, L. M. (1964). Theory of brightness and color contrast in human vision. *Vision Research*, 4, 135-154.

7. Stevens, J. C., & Stevens, S. S. (1963). Brightness function: Effects of adaptation. *Journal of the Optical Society of America*, 53, 375-385.

8. Stevens, S. S., & Diamond, A. L. (1965). Effect of the glare angle on the brightness function for a small target. *Vision Research*, 5, 649-659.

Cross References

- 1.706 Descriptive attributes of color appearance;
- 1.713 Brightness induction; *Handbook of perception and human performance*, Ch. 9, Sect. 6.3

1.721 Lightness Scales

Key Terms

Achromatic lightness scale; color appearance; gray scale; lightness; lightness scale; luminance; reflectance; uniform lightness scale

General Description

Lightness is the degree to which an object or area appears to emit light, judged in proportion with another, similarly illuminated stimulus that appears white.

The physical correlate of the perceptual attribute of lightness is the luminance factor of the object, which is the object's luminance, divided by the luminance of the perfect reflecting diffuser (i.e., a Lambertian surface) when identically illuminated. Thus, the luminance factor is essentially a measure of the object's ability to reflect visible light.

Uniform lightness scales have been developed for a variety of viewing conditions; most describe **achromatic** stimuli only, and thus are called *gray scales*. One way to produce a gray scale uses the method of *bisection*. The observer is told to select a gray sample midway between white and black. Then, two more grays are selected, one midway between white and the middle gray and the other midway between black and middle gray. This sequence of bisecting steps is repeated until a designated number of gray steps is reached (usually 10). Another method is called *confusability scaling*. The observer views black and selects a gray that is lighter by a just-noticeable difference (JND). Then, another gray that is one JND lighter than the first is selected. This is repeated until white is reached. Either method yields interval data, i.e., lightness steps that are equal, and the steps are therefore often assigned incrementing scalar numbers (e.g., 0-10, where 0 = black), to indicate their lightness values (V).

Numerous models have been developed to describe experimentally determined relationships between lightness scale value, V , and luminance factor, Y . Six are illustrated here, and are derived from different viewing conditions. Although the curves vary, the fundamental relationship remains the same: lightness increases rapidly as luminance factor increases at lower luminance factor levels, and the

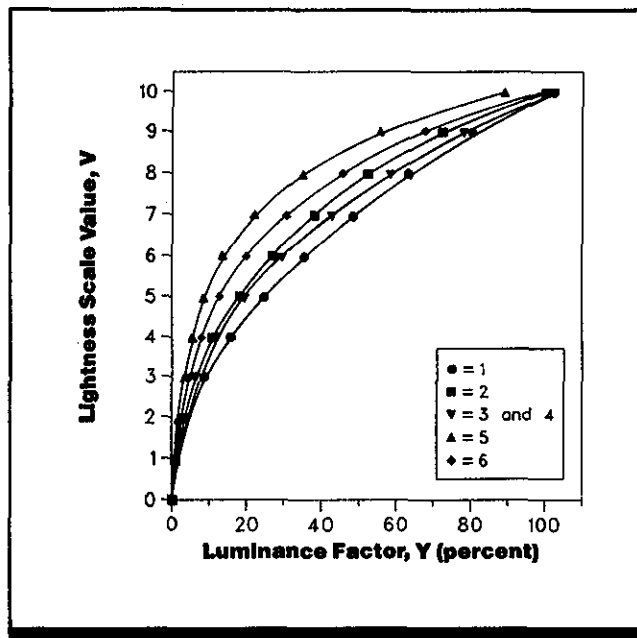

Figure 1. Relationships between lightness-scale value V and luminance factor Y , plotted in accordance with six models (see Table 1). $V = 0$ corresponds to a good pigment black ($Y = 0$); $V = 10$ corresponds to a good pigment white ($Y = 100$); $V = 5$ is a middle gray. (From Ref. 10)

rate of lightness increase tapers off as luminance factor increases. Table 1 describes the six models and the conditions under which each is appropriate.

Homochromatic lightness scales are related to achromatic scales, but apply to chromatic (colored) test areas that vary in lightness while hue and **chroma** remain constant. The functional relationship between V and Y is the same as for gray scales; typically a power function of the form $V = aY^p - Y_0$ (where a , p , and Y_0 depend on viewing conditions and individual differences and are empirically determined). However, the coefficients may take on different values.

Applications

Selection and specification of the allowable or required ratio of symbol luminance to background luminance, in achromatic display formatting and lightness coding, where specific levels of lightness are required.

Empirical Validation

The various curves exhibit important differences (i.e., middle gray [$V = 5$] for model 1 is at $Y = 22$; for model 5 it is at $Y = 10$). Differences are attributed to differences in the viewing conditions to which each is intended to apply, especially the luminance factor of the background against which the target sample is viewed. Under conditions similar to those for which data were collected, the models can provide useful indications of expected lightness values.

Table 1. Selected Formulas for Calculating Lightness-Scale Values V from Luminance Factors Y.

Model	Relationship between V and Y	Conditions/Derivation	Refs.
1	$V = 10 Y^{1/2}$	Used in connection with the original Munsell system. Applies best to observations with a white background	Ref. 7
2	$V = (1.474 Y - 0.00474 Y^2)^{1/2}$	A modified version of model 1. Applies best to observations with a middle-gray background of luminance factor $Y_b = 19.1$	Refs. 3, 5
3	$100Y = 1.2219V - 0.23111V^2 + \frac{0.23951V^3}{Y_{mgo}} - 0.021009V^4 + 0.0008404V^5$	Used in connection with the Munsell renotation system. Applies best to observations with a middle-gray background ($Y_b \approx 20$). Defines Munsell value in the Munsell renotation system. The luminance factor Y is relative to magnesium oxide taken as 97.5%; this gives a value of $Y = 102.568$ for $V = 10$	Ref. 6
4	$V = 116 (Y/Y_0)^{1/3} - 16$	CIE (1975) lightness function $L^* (= \Omega)$. The luminance factor Y_0 refers to the nominally white object-color stimulus; usually $Y_0 = 100$ (i.e. luminance factor of the perfect reflecting diffuser)	Ref. 1
5	$V = 0.25 + 5 \log Y$	Defines the gray scale of Color Harmony Manual and is based on Weber's law. Note that $V = 0$ corresponds to a good pigment black ($Y = 0.009$); $V = 10$ corresponds to a good pigment white ($Y = 0.891$). Applies best to observations with a gray background whose luminance factor is close to that of the gray chips being compared for their lightness difference	Refs. 2, 4, 10
6	$V = 6.1723 \log (40.7Y + 1)$	Used in connection with the gray scale of the German DIN color chart and is based on a modified Delboeuff formula. Applies best to observations with a gray background of luminance $Y_b \approx 50\%$	Ref. 8

Note: Models are illustrated in Fig. 1. Each equation represents an empirically determined quantitative relationship between the lightness-scale value V and luminance factor Y, for gray paint chips observed under various viewing conditions (primarily different background luminance factors).

Constraints

- Perception of an area's lightness is strongly influenced by the luminance factor of its background or surround. The background produces induction effects and influences **adaptation** of the eye, especially for small test areas (CRefs. 1.713, 1.715).
- In applying a lightness scale, it is critical that the model

selected was developed for the conditions to which it will be applied.

- Judgments of test area lightness may vary with the number of different observations in a given test situation.
- The degree of observer adaptation to surround illumination affects judgments of lightness.

Key References

1. Commission Internationale de l'Eclairage (CIE). (1978). *Recommendations on uniform color spaces, color-differences equations, psychometric color terms* (Supplement No. 2 of CIE Publication No. 15, E-1.3.1, 1971). Paris: CIE Central Bureau.
2. Foss, C. E., Nickerson, D., & Granville, W. C. (1944). Analysis of the Ostwald color system. *Journal of the Optical Society of America*, 34, 361-381.

3. Godlove, I. H. (1933). Neutral value scales, II. A comparison of results and equations describing value scales. *Journal of the Optical Society of America*, 23, 419.
4. Judd, D. B., & Wyszecki, G. (1975). *Color in business, science, & industry* (3rd ed.). New York: Wiley.
5. Munsell, A. E. O., Sloan, L. L., & Goodlove, I. H. (1933). Neutral value scales, I. Munsell neutral value scale. *Journal of the Optical Society of America*, 23, 394.

6. Newhall, S. M., Nickerson, D., & Judd, D. B. (1943). Final report of the O.S.A. subcommittee on spacing of the Munsell colors. *Journal of the Optical Society of America*, 33, 385-418.
7. Priest, I. G., Gibson, K. S., & McNicholas, H. J. (1920). *An examination of the Munsell color system, I. Spectral and total reflection and the Munsell scale of value* (U.S. National Bureau of Standards Technical Paper 167). Washington, DC: U.S. National Bureau of Standards.

8. Richter, M. (1953). Das System der DIN-Farbenkarte. *Die Farbe*, 1, 85-93.
9. Wyszecki, G. (1986). Color appearance. In K. R. Boff, L. Kaufman, & J. P. Thomas (Eds.), *Handbook of perception and human performance: Vol. 1. Sensory processes and perception*. New York: Wiley.
10. Wyszecki, G., & Stiles, W. S. (1982). *Color science* (2nd ed.). New York: Wiley.

Cross References

- 1.706 Descriptive attributes of color appearance;
1.712 Brightness constancy;

- 1.713 Brightness induction;
1.715 Model of brightness contrast;
1.720 Brightness scales

1.722 Color Specification and the CIE System of Colorimetry

Key Terms

Chromaticity; chromaticity coordinates; chromaticity diagram; CIE standard colorimetric observer; color matching function; color specification; colorimetric purity; colorime-

try; complementary wavelength; dominant wavelength; excitation purity; hue; purple line; saturation; spectral radiance distribution; spectrum locus; trichromacy; tristimulus values; wavelength

General Description

Color Specification

A basic problem in color research is how to precisely specify a given color. In casual conversation, a description such as "pale greenish yellow" will usually suffice; however, such a description is dependent upon a person's color vision and color experience. Furthermore, humans are capable of detecting extremely small color differences; several colors that are perceptibly different may be described as "pale greenish yellow."

In industrial and research applications, the ambiguities inherent in these verbal descriptions are unacceptable. Color must be specified with a level of accuracy that is more commensurate with human discrimination capabilities. In industry, for example, materials are manufactured whose color must absolutely match a standard. In research settings, it can be necessary to analyze subjects' behavior as a function of stimulus color and to report those colors so that they are reproducible. Furthermore, in both of these applications, mathematical analysis of color vision and the color-producing properties of materials can be useful. Verbal descriptions do not provide the required level of precision and so alternative methods have been developed.

The older method of precise color specification is to reference a physical standard. However, physical standards can be inconvenient because copies of the standards must be in the user's possession. It can be difficult to produce copies that match exactly, and both they and the original standard can become corrupted or lost. Also, specifying a color by referencing a physical standard provides no quantification of color properties and, thus, provides no basis for their mathematical analysis. A consequence of particular importance in industry is that there is no basis for calculating a color's deviation from its standard.

The most precise method of specifying color is to show the spectral radiance distribution of the light that produces it. This is accomplished by measuring and plotting the radiance of the light as a function of wavelength. (Because the human visual system is relatively insensitive to wavelengths shorter than 360 nm or longer than 830 nm, it is sufficient to measure radiance only within this range when one is concerned with human vision.) If the color is produced by a reflecting object, it may be preferable to determine its spectral reflectance distribution, rather than the spectral radiance distribution of the light reflecting from it. The spectral reflectance distribution is obtained by dividing the reflected radiance by the radiance of the illuminant as a function of wavelength. The advantage is that the spectral reflectance distribution is independent of the illuminant and permits the spectral radiance distribution of light reflected from the object to be calculated for any illuminant whose spectral radiance distribution is known.

Similarly, the spectral transmittance distribution may be preferable when dealing with an object that transmits light (e.g., a colored filter). The spectral transmittance distribution is obtained by dividing the radiance transmitted by the object by the radiance of the illuminant as a function of wavelength. One can then calculate the spectral radiance distribution of any light transmitted by the object, given the illuminant's spectral radiance distribution.

The use of spectral distributions to specify color is precise, but has two shortcomings. First, it can be difficult to visualize color based upon examination of a spectral distribution. Second, it is inefficient because it fails to take into account that different spectral radiance distributions can produce identical colors.

Colors that have different spectral radiance distributions, but nonetheless match, are called *metamers* (or *metameric pairs*). One way of explaining metamerism is to posit that the human visual system contains only three basic types of channels for distinguishing among lights of different spectral distributions. Thus, if two spectral radiance distributions produce the same channel activities, they will produce the same color, even though the distributions may be very different. The color-processing channels seem to receive signals from three basic types of color photoreceptors, which are called cones. Each type of cone integrates radiance over a different range of the spectrum, corresponding roughly with the long (red), medium (green), and short (blue) visible wavelengths. There is evidence that the channels also receive signals from the photoreceptors that are responsible for night vision (the rods), whose spectral sensitivity differs from that of the cones. However, the channels do not seem to process the rod signals independently. On the other hand, rods are located outside the area of the retina that correspond to the center of the visual field (i.e., the fovea), whereas cones are concentrated in this area. Therefore, the system as a whole behaves as though only three spectral sensitivities are involved, but these apparent sensitivities vary according to the size of the stimulus and the location of its image on the retina. Small (e.g., subtending 2 degrees of visual angle or less), centrally fixated targets tend to stimulate only cones and, thus, the channel sensitivities are those of the cones. As target size increases and/or its image moves away from the center of the visual field, the rod contribution increases and, thus, the channel sensitivities increasingly represent a combination of cone and rod sensitivities.

The preceding description of color vision is very simplified. No vision scientist would find it wholly satisfactory and even those who agree that it is basically accurate would disagree regarding the nature of the channels and the extent to which available evidence demonstrates their existence. Nonetheless, it is consistent with most evidence and pro-

vides a necessary background for understanding the material that follows.

Color Matching

It is possible to match any color using a mixture of no more than three properly chosen colored lights. (This appears to be a consequence of the fact that there are only three types of color-processing channels.) For this reason, normal color vision is said to be trichromatic. Persons whose color vision is deficient can often match all colors using only two or, rarely, one light. In general, the three colors of light that permit the broadest range of colors to be matched are reds, greens, and blues that are highly saturated (i.e., highly colorful and pure in appearance). This is why red, green, and blue dots or stripes are used on television screens. However, while any color can be matched by a mixture of only three properly chosen lights, no single set of three colored lights can match all colors. This limitation is due primarily to the overlap in the spectral sensitivities of the three cone types.

In 1931, the Commission Internationale de l'Eclairage (CIE, an international commission which has developed standards for the measurement of light) introduced a numerical method of color measurement and specification that takes advantage of the trichromacy of color vision. The method is based on the data from color-matching experiments in which a single monochromatic light (light containing only one wavelength) is matched by mixtures of three monochromatic lights. To understand these experiments, it is helpful to pretend for a moment that all colors can be matched by a mixture of red, green, and blue. Observers view a display divided into two adjacent fields. One field contains a monochromatic light of unit radiance and the other field contains a mixture of monochromatic red, green, and blue primaries. The observer then adjusts the mixture so that it matches the single light.

Repeating this procedure for lights covering the visible spectrum establishes the proportional amounts of red, green, and blue primaries that are needed to match all wavelengths of unit radiance. If one assumes that the radiance of a given wavelength has no effect on the requisite proportions of the primaries, then the amounts of the three primaries needed to match any wavelength can be calculated, even if the radiance differs from that used in the experiment. Furthermore, because non-monochromatic lights can be modeled mathematically as mixtures of monochromatic lights, one can also calculate the amounts of the red, green, and blue primaries that are needed to match any color of light. The numerical specification of these three amounts and the wavelengths of the primaries will uniquely and precisely identify any color.

In practice, of course, these experiments cannot be performed because no single set of three primaries can be mixed to match all wavelengths. Matches could always be obtained if one of the primaries could be negative, i.e., could be subtracted from the other two, but this is physically impossible. However, equivalent results can be obtained by adding, say, the red primary to the single monochromatic light (instead of subtracting it from the blue and green primaries) and letting the observer adjust both the red primary and, in the other field, the mixture of green and blue primaries. When this procedure is used, a match can always be obtained between the two fields using only a single set of three primaries. Because the visual system treats

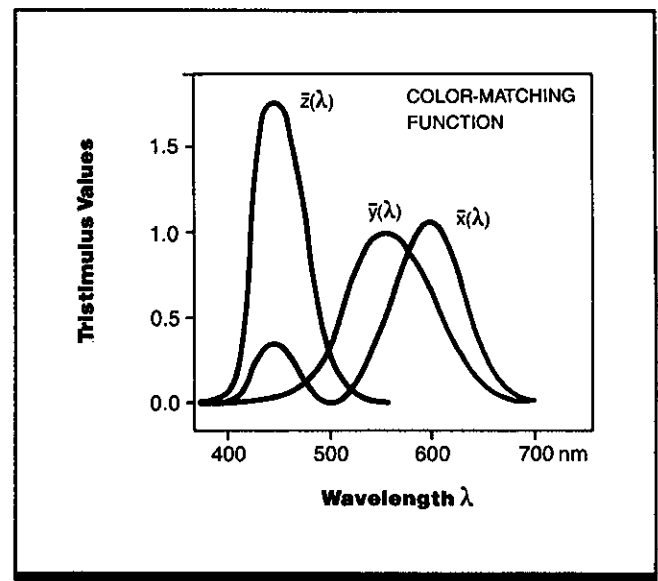

Figure 1. $\bar{x}(\lambda)$, $\bar{y}(\lambda)$, $\bar{z}(\lambda)$ color-matching functions of the CIE 1931 standard colorimetric observer. The figure shows the amounts of the three imaginary primaries (tristimulus values) that match each spectral wavelength. (From Ref. 7)

color mixtures additively, the amount of red that must be added to the monochromatic light to obtain a match will be the same as the amount that would have to be subtracted from the green plus blue field to obtain a match, if this were possible.

This approach allows specification of all colors using only three numbers that represent quantities of three given primaries. These numbers are called tristimulus values. The only complication is that one of the tristimulus values will be negative for many wavelengths. One tristimulus value will be negative from some non-monochromatic lights, as well, their identities depending on the primaries selected.

CIE 1931 Standard Colorimetric Observer

The procedure described above forms the basis of the color-matching experiments from which the CIE derived its standard system for color measurement and specification. Data from many different observers were combined and the results considered to represent the color-matching behavior of an average person having normal color vision. The use of negative numbers poses complications, however, when calculating tristimulus values. Also, it was deemed desirable to arrange the system so that, when a color's tristimulus values were calculated, one of the tristimulus values would equal the color's luminance. This provides a computational convenience because it eliminates the need to calculate luminance separately. (These computational issues were more important before the advent of digital computers.) Therefore, the CIE transformed the results to express them in terms of three imaginary primaries called X, Y, and Z, which are defined in such a way that they can be mixed (mathematically) in positive amounts to match all real colors. In addition, the Y primary is defined so that it represents luminance only. Thus, the X and Z primaries have no luminance and a color's Y tristimulus value equals its luminance.

The CIE tabulated the X , Y , Z tristimulus values for wavelengths having unit radiance and ranging from 380-780 nm in 5-nm increments. The resulting table defines the CIE 1931 standard colorimetric observer and the three columns of numbers (one each for X , Y , and Z), contained in it are known as the CIE 1931 $\bar{x}(\lambda)$, $\bar{y}(\lambda)$, $\bar{z}(\lambda)$ color-matching functions, which are plotted in Figure 1. (The CIE later expanded the table to cover the range from 360-830 nm in 1-nm increments.)

It is worthwhile to explain that the means which the CIE used to force all luminance onto the Y primary was to make the $\bar{y}(\lambda)$ color-matching function the same as the CIE 1924 photopic luminosity function (CRef. 1.110). The imaginary nature of the primaries, X , Y , and Z should be emphasized. No real lights can have zero luminance, as X and Z do, nor can a real light have luminance alone, as Y does.

The CIE 1931 standard colorimetric observer represents the behavior of an imaginary, idealized observer who has normal color vision, performs the color-matching task with perfect consistency, and does so in a way that is representative of the average person. Of course, no real person is perfectly consistent and there are differences in color vision even among persons whose color vision is classified as being normal. Therefore, no real person will match colors in exactly the same way as the standard observer. However, the standard observer provides a satisfactory approximation in most cases.

The fact that three color-matching functions suffice to describe color-matching behavior is a direct consequence of the trichromacy of normal color vision. The CIE 1931 color-matching functions are not, however, the same as the spectral sensitivities of any real photoreceptors (although the $\bar{z}(\lambda)$ color-matching function does seem to approximate the spectral sensitivity of the short-wavelength cones). They may be regarded as linear transformations of the spectral sensitivities associated with the cones of the CIE standard colorimetric observer.

The calculation of CIE 1931 tristimulus values for a given color consists of multiplying its spectral radiance distribution by each of the three color-matching functions $\bar{x}(\lambda)$, $\bar{y}(\lambda)$ and $\bar{z}(\lambda)$, integrating with respect to wavelength, and multiplying by a scaling constant which converts the resulting three numbers from radiometric to photometric units. (The constant is 683, which is the number of lumens in one watt of monochromatic light having a wavelength of 555 nm.) As explained previously, the resulting Y tristimulus value is the color's **photopic** luminance.

If color is that of a reflecting object, its spectral reflectance distribution can be used instead, in which case the tristimulus values will describe its color when it is illuminated by a source having equal radiance at all visible wavelengths. Alternatively, the spectral reflectance distribution can first be multiplied by a light's spectral radiance distribution (e.g., one of the CIE standard illuminants), in which case the tristimulus values will describe the object when illuminated by that light. In either instance, tristimulus values for reflecting objects are usually normalized with respect to the perfect reflecting diffuser (i.e., an imaginary standard that diffuses light perfectly and has a reflectance of unity) and, thus, the Y tristimulus value becomes the object's luminance factor. (A reflecting object's luminance factor is the ratio of its luminance to that of a perfect reflecting diffuser under identical illuminating and measuring conditions.) The reason for this practice is that an object's luminance depends

upon its illuminance and, therefore, its luminance factor is often of greater interest.

If the color is that of a transmitting object, options analogous to those for reflecting objects exist. In this case, however, normalization is made with respect to the perfect transmitting diffuser (i.e., an imaginary standard that diffuses light perfectly and has a transmittance of unity). The normalized Y tristimulus value for a transmitting object is still its luminance factor but, for a transmitting object, the luminance factor is the ratio of the object's luminance to that of the perfect transmitting diffuser under identical conditions of illuminance and measurements.

The CIE 1931 color-matching functions enable colors to be specified succinctly and precisely. Knowledge of a color's tristimulus values enables another person to produce color that will be judged by most people to match the original color at least reasonably well. This can be accomplished merely by ensuring that the second color has the same tristimulus values, which is the same as ensuring that the colors are metamers. It is not necessary that the spectral radiance distributions be the same. In fact, the spectral radiance distributions may be very different.

It is important to realize that, although the tristimulus values define the mixture of three primaries that will match a given color, they do not specify the resulting color perception. This is because color perception is subject to many influences besides the object's spectral radiance distribution and, therefore, the same spectral radiance distribution can produce different perceptions under different viewing conditions (CRef. 1.707). One of the most familiar examples occurs when the viewer adapts to a colored light before viewing the object. For example, if the viewer stares at a red surface and then views a surface that would normally appear white, it will instead appear green. The CIE never intended its colorimetric system to be used to define color perceptions. It is only a method for specifying color by defining how to reproduce it.

CIE 1931 Chromaticity Diagram

A highly useful diagram can be produced based upon proportions among colors' tristimulus values. Let us define

$$x = \frac{X}{X+Y+Z}, \quad y = \frac{Y}{X+Y+Z}, \quad (1-3)$$

and

$$z = \frac{Z}{X+Y+Z},$$

where X , Y , and Z are a color's tristimulus values and x , y , and z are the associated proportions required to obtain a color match. They represent chromaticity, i.e., the purely chromatic aspects of color matching, independent of luminance. Note that they always sum to unity. Therefore, if the values of x , y , and z for all possible colors are plotted in a three-dimensional space having x , y , and z as its axes, the result is a plane containing all chromaticities, both real and imaginary. The values of x , y , and z for any given color specify its location on the chromaticity plane and are, therefore, referred to as *chromaticity coordinates*.

It is useful to have a diagram that shows the domain of real chromaticities and against which chromaticity coordinates can be referred. A diagram of this type can be easily derived by plotting the coordinates of the visible wavelengths. Because all chromaticities lie on a plane, this dia-

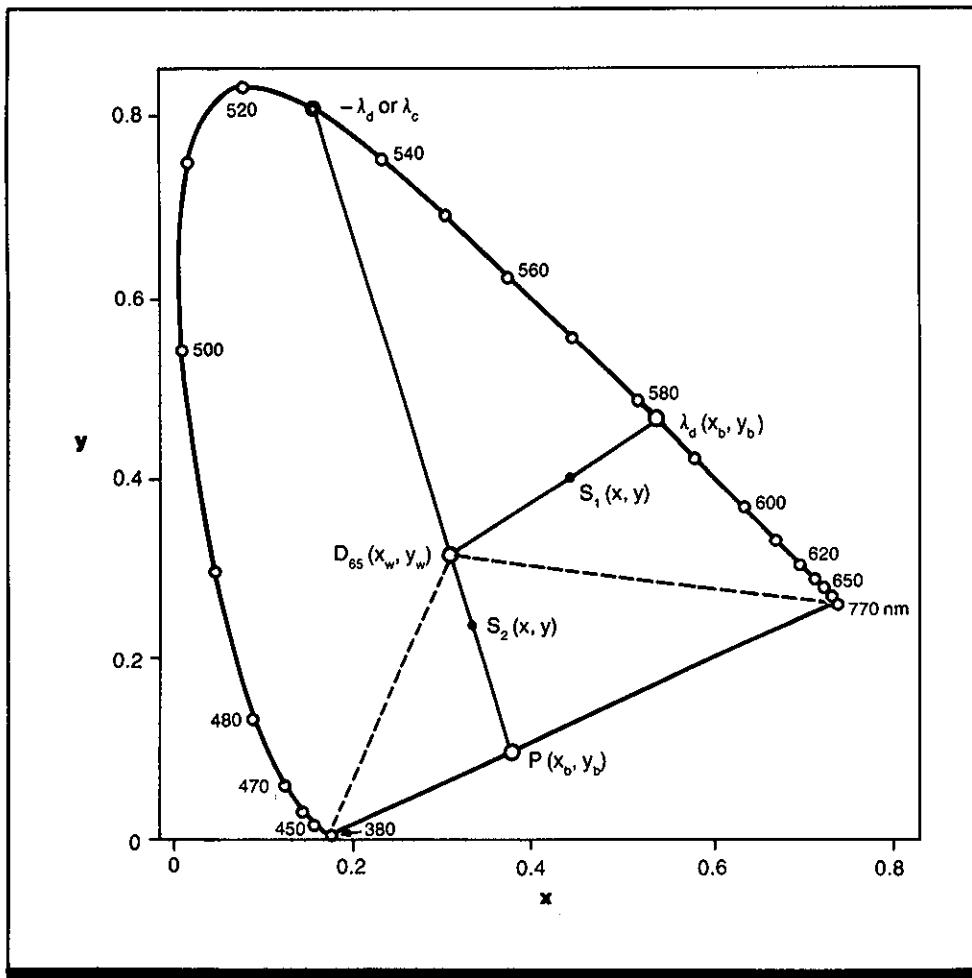

Figure 2. The CIE 1931 (x, y) -chromaticity diagram. $\lambda_d(x_b, y_b)$ is the dominant wavelength of a color stimulus S_1 , with a chromaticity point $S_1(x, y)$ determined with respect to CIE standard illuminant D_{65} whose chromaticity coordinates are denoted by x_w, y_w . λ_c (or $-\lambda_d$) is the complementary wavelength of a color stimulus S_2 with a chromaticity point $S_2(x, y)$ with respect to D_{65} . The intersection $P(x_b, y_b)$ of the line running through the chromaticity points $D_{65}(x_w, y_w)$ and $S_2(x, y)$ with the purple line is needed to calculate the excitation purity of S_2 , as explained in the text. (From Ref. 7)

gram can be drawn in two dimensions, i.e., only two coordinates are needed. For example, if the coordinates x and y are plotted for the visible wavelengths and the end-points (the points representing 360 and 830 nm) are joined by a straight line, the diagram given in Figure 2 results. This diagram shows the projection of the real portion of the chromaticity plane onto the $z = 0$ plane.

The diagram in Fig. 2 is only of an infinite number of projections that could be chosen. However, it is advantageous to choose one standard projection for universal use and reference. Figure 2 has special significance because it is the standard projection that was chosen by the CIE. It is called the CIE 1931 (x, y) -chromaticity diagram. The curved line representing the visible wavelengths is called the *spectrum locus* and the straight line which closes the figure is called the *purple line*. All visible wavelengths lie on the spectrum locus, all pure purples (i.e., mixtures of 360 and 830 nm light) lie on the purple line, and all other real colors lie in the figure's interior.

A color can be completely specified by either its tristimulus values or its luminance and chromaticity coordinates. When a color is specified in terms of chromaticity coordinates, only two need to be indicated; the third is then completely defined (because $x + y + z = 1$). By convention, x and y are used for this purpose. Therefore, a color can be specified either in terms of $X, Y,$ and Z or in terms of $x, y,$ and Y .

The CIE 1931 chromaticity diagram has several useful

properties. One is that all chromaticities that can be produced by mixing two primaries in positive amounts lie on a straight line between the coordinates of those two primaries. Similarly, all chromaticities that can be produced by mixing three primaries (e.g., a color CRT's red, green, and blue guns) lie on and within the triangle formed by the coordinates of the primaries. This property generalizes to polygons formed by any number of primaries and is shared by all chromaticity diagrams.

The CIE 1931 chromaticity diagram can be used to define a quantity which correlates (imperfectly) with a color's hue. This quantity is the color's dominant wavelength, which is the wavelength that, when mixed with the correct amount of white light, yields a chromaticity that matches that of the color. To obtain a color's dominant wavelength, one must first select a reference white. Ordinarily, one of the CIE standard illuminants (illuminants C and D_{65} are common choices) or the point of equal energy (i.e., the coordinates of light having equal radiance at all visible wavelengths, which are $x = 1/3, y = 1/3$) is used for this purpose. A line is then drawn from the coordinates of the white through the coordinates of the color to the spectrum locus. The wavelength at which the line intersects the spectrum locus is the color's dominant wavelength (See Fig. 2). The dominant wavelength of a color whose chromaticity coordinates match that of the reference white is, of course, undefined.

In some cases, the line produced by the procedure described above will intersect the purple line instead of the spectrum locus. This means that the color does not have a dominant wavelength, i.e., it cannot be reproduced by mixing monochromatic light with the reference white. The convention in such cases is to denote the intersected location on the purple line by the color's complementary wavelength (i.e., the wavelength that, when mixed in proper proportion with the color, matches the reference white), followed by the letter *c*. (An alternative notation is to show the complementary wavelength as a negative number.) The complementary wavelength is determined by finding the point on the spectrum locus which is intersected by a line passing from the color in question through the reference white on the spectrum locus (See Fig. 2). It is important to understand, though, that the complementary wavelength denotes a location on the purple line when it is followed by the letter *c* or shown as a negative number, even though the wavelength itself lies on the spectrum locus. Thus, for example, the chromaticity coordinates associated with a wavelength of 555 nm lie on the spectrum locus, but the coordinates associated with 555*c* will ordinarily lie on the purple line. ("Ordinarily" because the exact location depends on the reference white. This underscores the fact that it is always necessary to specify the reference white when specifying either dominant or complementary wavelength. Otherwise, the specification is ambiguous.)

The chromaticity diagram can also be used to define a quantity which correlates (imperfectly) with a color's saturation. This quantity is the color's *excitation purity*, which is a proportion that indicates how close the color comes to having the maximum saturation possible at that color's dominant wavelength. Excitation purity is the ratio of two distances on the chromaticity diagram. The numerator is the distance from the color's coordinates to a reference white.

The denominator is the distance from the coordinates of the color's dominant wavelength to the reference white. (For colors that have no dominant wavelength, the denominator is the distance from the reference white to the point on the purple line that is intersected when computing wavelength; See Fig. 2.) Thus, the excitation purity of all colors on the spectrum locus and purple line is unity. The excitation purity of a color having the same chromaticity as the reference white is zero. Two equivalent equations for calculating excitation purity (P_e) are

$$P_e = (x - x_w)/(x_d - x_w) \text{ and} \tag{4}$$

$$P_e = (y - y_w)/(y_d - y_w), \tag{5}$$

where x and y are the chromaticity coordinates of the color whose excitation purity is being calculated, x_d and y_d are the coordinates of the color's dominant wavelength, and x_w and y_w are the coordinates of the reference white. If the color has no dominant wavelength, x_d and y_d are the coordinates on the purple line which are intersected by a line drawn from the reference white through the color to the purple line.

Sometimes a different quantity is used as a psychophysical correlate of saturation. This quantity is *colorimetric purity*, which indicates a color's deviation from a reference white. Colorimetric purity is the ratio of two luminances. The numerator is the luminance of the monochromatic light which, when mixed with an appropriate amount of the reference white, matches the color in both chromaticity and luminance. The denominator is the color's luminance. Thus, colorimetric purity is unity for all colors on the spectrum locus (because no white light is needed to obtain a match) and is zero for the reference white (because no monochromatic light is needed).

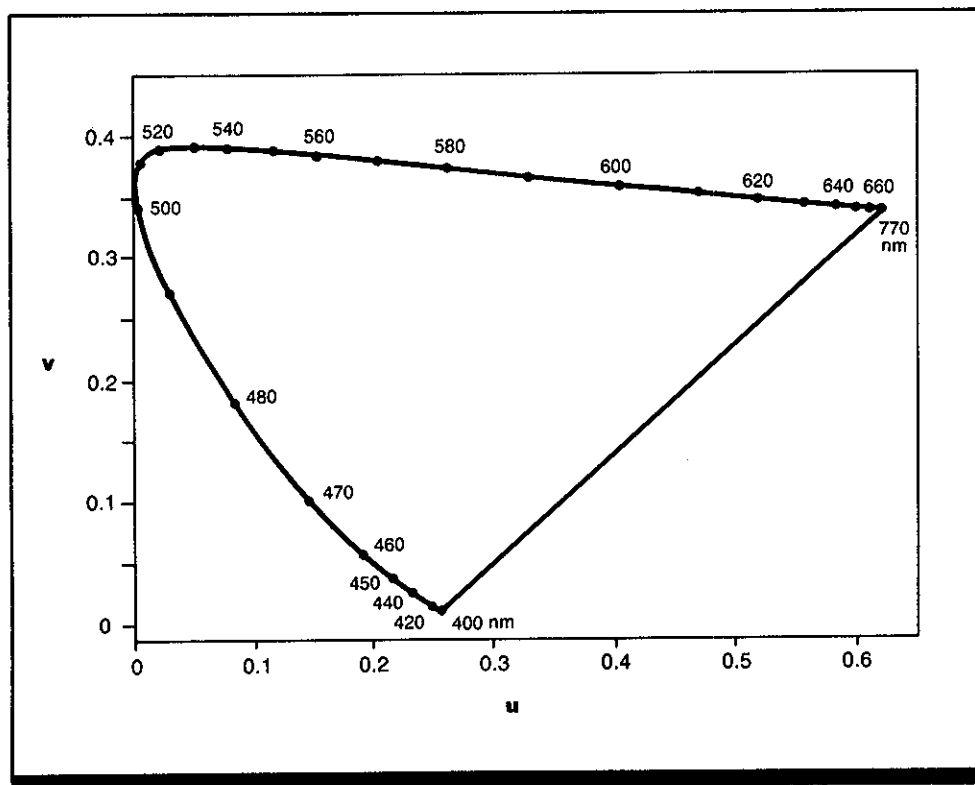

Figure 3. CIE 1960 uniform chromaticity scale diagram. (From Ref. 7)

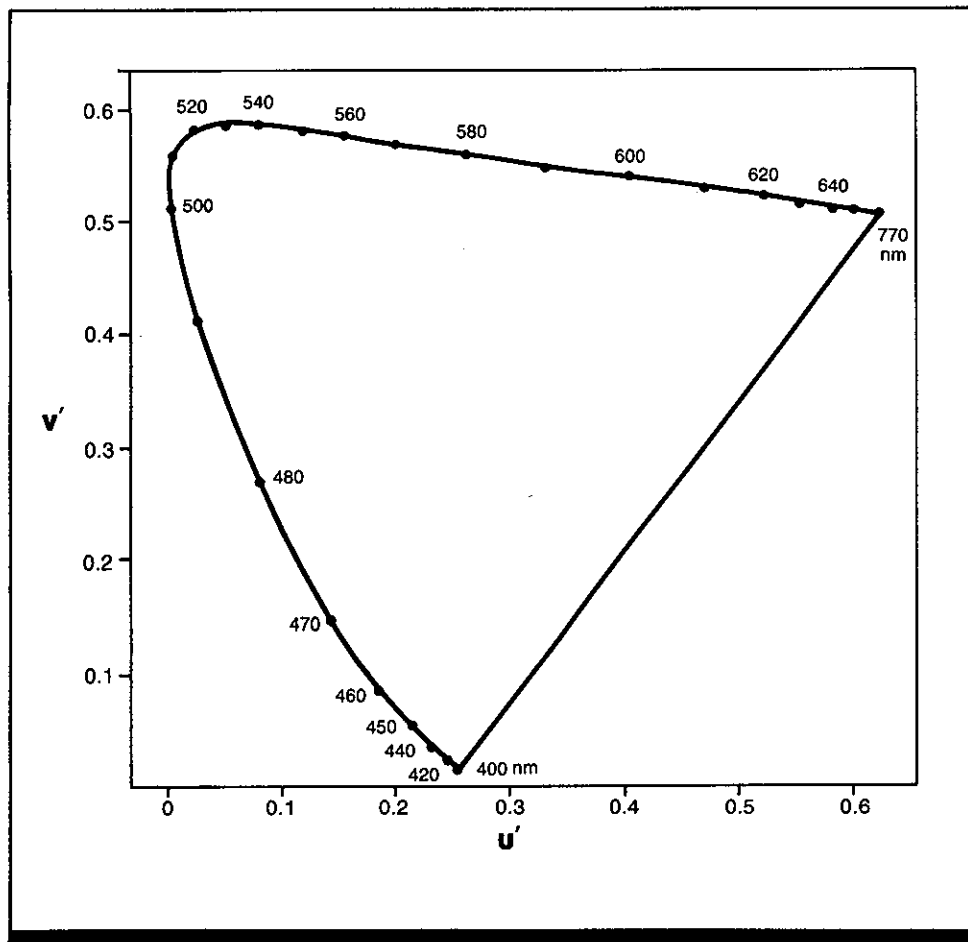

Figure 4. CIE 1976 uniform chromaticity scale diagram. (From Ref. 7)

This definition breaks down for colors that have no dominant wavelength, however, because they cannot be produced by mixing monochromatic and white light. Two conventions exist for handling such colors. The modern convention, which is recommended by the CIE, defines the numerator as the luminance of the color lying on the purple line which, when mixed in an appropriate amount with the reference white, matches the original color. (The color referred to in the numerator will be a mixture of monochromatic lights having wavelengths of 360 and 830 nm.) Thus defined, the colorimetric purity of colors that have no dominant wavelength ranges between zero and unity, just as is the case for colors that have dominant wavelengths. The older convention defines the numerator as the luminance of the color's complementary wavelength which, when mixed in an appropriate amount with the color, matches the reference white. Because this involves adding luminance to the color being measured, though, the added luminance is treated as a negative number in the question. (The reasoning is that which is invoked for the color-matching experiment.) Thus defined, colorimetric purity for colors that have no dominant wavelength is always negative. Furthermore, very large negative numbers can result for colors that have no dominant wavelength and lie near the blue corner of the chromaticity diagram, and there are discontinuities in the values obtained as one moves on the diagram from colors that have a dominant wavelength to those that do not. Therefore, the modern convention is preferred, but it is worthwhile to be aware that there are two.

Two (equivalent) equations which express the modern definition of colorimetric purity (P_c) are

$$P_c = Y_d/Y \quad (6)$$

$$P_c = (y_d/y) P_e \quad (7)$$

where Y_d is the luminance of the wavelength which, when mixed in the correct proportion with the reference white, matches the color, Y is the color's luminance, and y_d and y are the y -chromaticity coordinates of the wavelength and color, respectively. If the color has no dominant wavelength, Y_d is the luminance of the color on the purple line which, when mixed in the correct proportion with the reference white, matches the original color and y_d is the y -chromaticity coordinate of the location on the purple line which is intersected by a line drawn from the reference white through the color to the purple line.

Equations 6 and 7 correspond with the older definition of colorimetric purity for colors that have a dominant wavelength. For colors that do not, however, the older equations (all equivalent) are

$$P_c = -Y_c/Y, \quad (8)$$

$$P_c = (y_c/y) (x - x_w) / (x_c - x_w), \quad \text{and} \quad (9)$$

$$P_c = (y_c/y) (y - y_w) / (y_c - y_w), \quad (10)$$

where x , y , x_w , y_w , and Y are defined as above, Y_c is the luminance of the complementary wavelength which must be added to the color to match the reference white, and x_c and

y_c are the complementary wavelength's chromaticity coordinates.

Some researchers prefer colorimetric purity over excitation purity because it tends to correlate better with saturation. However, its calculation is more complex and neither measure predicts saturation particularly well. Therefore, although colorimetric purity is encountered occasionally when reading literature dealing with color vision, excitation purity is more common.

CIE 1960 UCS Diagram

Although the CIE 1931 chromaticity diagram is very useful, distances among chromaticity coordinates do not correspond in any consistent way with perceived differences. For example, if color *A* has coordinates $x = 0.2, y = 0.2$, color *B* has $x = 0.3, y = 0.3$, and color *C* has $x = 0.4, y = 0.4$, the perceived difference between *A* and *B* will, in general, be greater than that of *B* and *C*, even though the distances involved are the same. Similarly, the distance corresponding to the smallest chromatic difference that can be reliably detected varies as a function of location on the diagram. Another way of expressing these difficulties is to say that the spacing of colors on the diagram is not perceptually uniform.

The CIE 1931 chromaticity diagram's lack of perceptual uniformity is not surprising because the CIE made no attempt to incorporate this property. The diagram was meant only to provide a convenient representation of color-matching behavior, as embodied in the standard colorimetric observer. More recently, however, the CIE has developed transformations intended to yield improved perceptual uni-

formity. (For an explanation of these transformations, the reader is referred to Refs. 1, 2, 3, 7. The first is the CIE 1960 uniform chromaticity-scale (UCS) diagram, the transformation for which is

$$u = \frac{4x}{-2x + 12y + 3} = \frac{4X}{X + 15Y + 3Z}, \quad (11, 12)$$

$$v = \frac{6y}{-2x + 12y + 3} = \frac{6Y}{X + 15Y + 3Z}, \quad (13, 14)$$

where u and v are chromaticity coordinates on the transformed diagram, which is shown in Fig. 3.

CIE 1976 UCS Diagram

The CIE 1960 UCS diagram is mainly of historical interest now because it has been superseded by the CIE 1976 UCS diagram. The 1976 USC transformation is

$$u' = \frac{4x}{-2x + 12y + 3} = \frac{4X}{X + 15Y + 3Z}, \quad (15, 16)$$

$$v' = \frac{9y}{-2x + 12y + 3} = \frac{9Y}{X + 15Y + 3Z}, \quad (17, 18)$$

where u' and v' are chromaticity coordinates on the 1976 UCS diagram, which is shown in Figure 4. Note that $u' = u$ and $v' = 1.5v$.

CIE 1964 10-Degree Standard Colorimetric Observer

The CIE 1931 standard colorimetric observer is based upon viewing conditions that involve relatively small targets (2 deg of visual angle). Because color-matching behavior

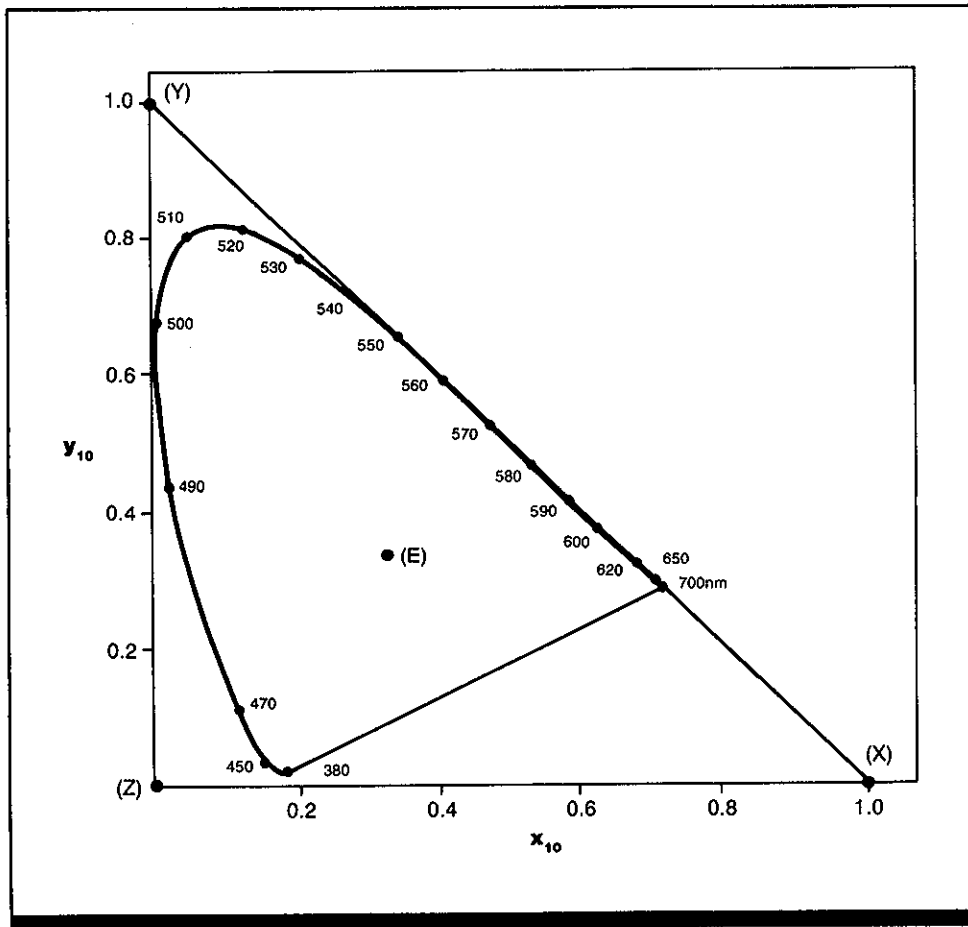

Figure 5. CIE 1964 (x_{10}, y_{10})-chromaticity diagram for the 10-deg (large field) standard colorimetric observer. (From Ref. 7)

changes systematically (although by a small amount) as a function of target size, questions arose concerning the range of stimulus sizes over which the 1931 observer is valid. (These changes result from rod contributions, as described earlier.) The CIE eventually resolved this issue by recommending that the 1931 observer be used for stimuli subtending 1-4 deg and by introducing a supplementary observer for targets subtending 4-10 deg. This large-field observer is known as the CIE 1964 10-deg standard colorimetric observer, which is defined by the color matching functions $\bar{x}_{10}(\lambda)$, $\bar{y}_{10}(\lambda)$ and $\bar{z}_{10}(\lambda)$. It was derived by performing color-matching experiments in which the stimulus subtends 10 deg. The associated chromaticity diagram is shown in Fig. 5. It can be seen, by comparing Figs. 2 and 5, that the 1931 and 1964 observers are very similar.

Useful Colorimetric Relationships

When performing colorimetric calculations, it is often helpful to be aware of the following relationships, all of which can be derived from Equations 1-3:

$$X = xY/y, \quad (19)$$

$$Z = zY/y, \quad \text{and} \quad (20)$$

$$X + Y + Z = X/x = Y/y = Z/z. \quad (21)$$

Some elaboration on color-mixture calculations may also be instructive. If color *A* consists of a mixture of lights *B* and *C*, then

$$X_A = X_B + X_C, \quad (22)$$

$$Y_A = Y_B + Y_C, \quad \text{and} \quad (23)$$

$$Z_A = Z_B + Z_C; \quad (24)$$

where X_A , Y_A , and Z_A are color *A*'s tristimulus values, etc. In other words, the tristimulus values of any color mixture are equal to the sums of its constituent colors' tristimulus values.

A slightly more complicated example of color mixture, which is relevant when working with color CRTs, is

$$\begin{bmatrix} X \\ Y \\ Z \end{bmatrix} = \begin{bmatrix} x_R/y_R & x_G/y_G & x_B/y_B \\ 1 & 1 & 1 \\ z_R/y_R & z_G/y_G & z_B/y_B \end{bmatrix} \begin{bmatrix} Y_R \\ Y_G \\ Y_B \end{bmatrix}, \quad (25)$$

where x_R , x_G , y_R , etc., are the chromaticity coordinates of the CRT's red, green, and blue primaries, Y_R , Y_G , and Y_B are the luminances to which the red, green, and blue primaries (respectively) have been set, and X , Y , and Z are the tristimulus values of the color which appears on the CRT screen. Note that, if the 3×1 vector of luminances is denoted by L , the 3×3 matrix containing chromaticity coordinates is denoted by C , and the 3×1 vector of tristimulus values is denoted by T , Eq. 25 implies that

$$L = C^{-1}T. \quad (26)$$

That is, the luminances which are needed from the red, green, and blue CRT primaries to produce a desired color can be calculated by multiplying the color's tristimulus values by the inverse of matrix C .

Key References

1. Bartleson, C. J. (1980). Colorimetry. In C. J. Bartleson & F. Grum (Eds.), *Optical radiation measurements, Vol. 2: Color measurement* (pp. 33-148). New York: Academic Press.
2. Judd, D. B., & Wyszecki, G. (1975). *Color in business, science,*

and industry (3rd ed.). New York: Wiley.

3. MacAdam, D. L. (1981). *Color measurement*. New York: Springer-Verlag.

4. Pokorny, J., & Smith, V. (1986). Colorimetry and color discrimination. In K. R. Boff, L.

Kaufman, & J. P. Thomas (Eds.), *Handbook of perception and human performance: Vol. 1. Sensory processes and perception*. New York: Wiley.

5. Wright, W. D. (1964). *The measurement of colour* (3rd ed.). Princeton: D. Van Nostrand.

6. Wyszecki, G. (1986). Color appearance. In K. R. Boff, L. Kaufman, & J. P. Thomas (Eds.), *Handbook of perception and human performance: Vol. 1. Sensory processes and perception*. New York: Wiley.

7. Wyszecki, G. & Stiles, W. S. (1982). *Color science* (2nd ed.). New York: Wiley.

Cross References

- 1.104 Measurement of radiant and luminous energy;
- 1.110 Luminous efficiency (spectral sensitivity);

1.301 Scotopic and photopic (rod and cone) vision;

1.702 Color mixture and color matching;

1.703 Colorimetric purity and excitation purity;

1.704 Chromaticity discrimination;

1.707 Factors influencing color appearance

1.723 Color-Order Systems

Key Terms

Additive color mixture; color appearance; color-order system; colorant mixture; subtractive color mixture

General Description

A color-order system is a rational plan of ordering and specifying all object colors within a limited domain: a set of material standards is selected and displayed to represent the entire set of object colors being considered. There are three major types of color-order systems, each based on a different principle of organization: (1) the principle of additive mixture of color stimuli, (2) the principle of colorant mixture, and (3) the principle of color appearance. Examples of each type of system will be described.

1. In color-order systems based on additive color mixture, color scales are generated by systematically varying the settings of a **tristimulus colorimeter** or a (rotating **color wheel** sector disk). These devices can add chromatic or **achromatic** components in specified proportions to produce color mixtures with desired properties. Chips can be painted to match the colors that are produced. Two examples are the *Ostwald Color System* and the *Ridgway Color System*. Ostwald used a double cone arrangement of colors in which grays are distributed between black and white along an axis perpendicular to the hue circle. The various tints of each hue from white to fully saturated are arranged along a line from the apex of the double cone down along the surface to the center rim; darker shades of the same tints are on cones parallel to the outer surface with the darkest shade on the lower of the two cones. Ostwald spaced the "pure" hues around the rim at angles in accordance with the magnitude of their differences, distributed the grays on the axis in proportion to their reflectances, and distributed the tints in proportion to color, white, and black content (Ref. 2).

In the Ridgway system, 35 different **dominant** (or **complementary**) **wavelengths** are represented. Color samples are arranged on each page with light samples grading down through eight steps to black at the bottom. Each column shows seven chromatic colors of constant dominant wavelength obtained by painting matches for three color wheel mixtures of a color with white and three mixtures of the same color with black. The seven colors are usually seen as having about the same hue.

2. In systems based on principles of colorant mixture, colors are developed by mixing a limited number of pigments or dyes in systematically varied proportions. Examples are the *Plochere Color System* and the *Martin-Senour Nu-Hue System*. Colorant mixtures are subtractive (i.e., pigments reflect some wavelengths of light while absorbing or "subtracting out" others; the hue seen depends on the

wavelengths that are reflected). Spacings of color samples in these systems are very different from those of the other types in that the mixtures of pigments do not necessarily result in colors perceived to have constant hue.

These systems show what can be produced by mixtures of the base colorants. For example, the Nu-Hue system is developed by combinations of six particular chromatic base paints and one near-black and one white paint. For each of the 1,000 colors produced, the weight and volume of each base paint is specified and a match can be produced by weighing out or measuring these amounts. In the Plochere system there are 26 basic hues. Each hue has five shades produced by adding progressive amounts of base paints to a near-black of the same hue. Seven tints for each of the 156 colors (26×6) are produced by adding increasing amounts of white paint.

Color-order systems intermediate between the additive color mixture types and subtractive colorant mixture types also exist. These are obtained by using a screen-plate process of printing and varying the screening systematically. Examples are the *Maerz and Paul Dictionary of Color*, the *Villalobos Colour Atlas*, and the *Hickethier System*. Using progressive amounts of coverage by the printing process (i.e., progressively denser screens), a series of colors from the white of the paper to the color of the ink, printed solid, is produced. Such a series produces color mixtures by the juxtaposition of small dots unresolvable by the eye. If rows of a series of a second colorant are printed on top of the series of the first colorant, a two-dimensional array of the mixtures of the two colorants with the white of the paper is produced.

3. The third type of color-order system is based on color appearance (color perception). In these systems, material standards (color samples) are selected to represent scales of constant hue, constant **saturation**, and constant **lightness**, each one spaced uniformly in accordance with the perceptual judgments of observers with normal color vision. The two main examples are the *Munsell Color System* (CRef. 1.724) and the *Optical Society of America (OSA) Color System* (CRef. 1.725.)

The Munsell system is organized into separate charts representing subjective scales of constant hue, saturation, and lightness. Each color chip is identified by three symbols corresponding to each of these dimensions. In the OSA system a regular rhombohedral lattice arrangement of color samples is used to construct a system in which all the color samples are perceptually equidistant from a given color. A three-dimensional scale is needed when the color differences being judged are a combination of differences in lightness, hue, and saturation.

Applications

Selection of colors and color schemes, color matching, color printing and dyeing, color specification.

Key References

1. Judd, D. B., & Wyszecki, G. (1975). *Color in business, science, and industry* (3rd ed.). New York: Wiley.
 2. MacAdam, D. L. (1981). *Color measurement: Theme and variations*. New York: Springer Verlag.
-

Cross References

- 1.724 Color-order systems: Munsell system;
- 1.725 Color-order systems: Optical Society of America System

1.724 Color-Order Systems: Munsell System

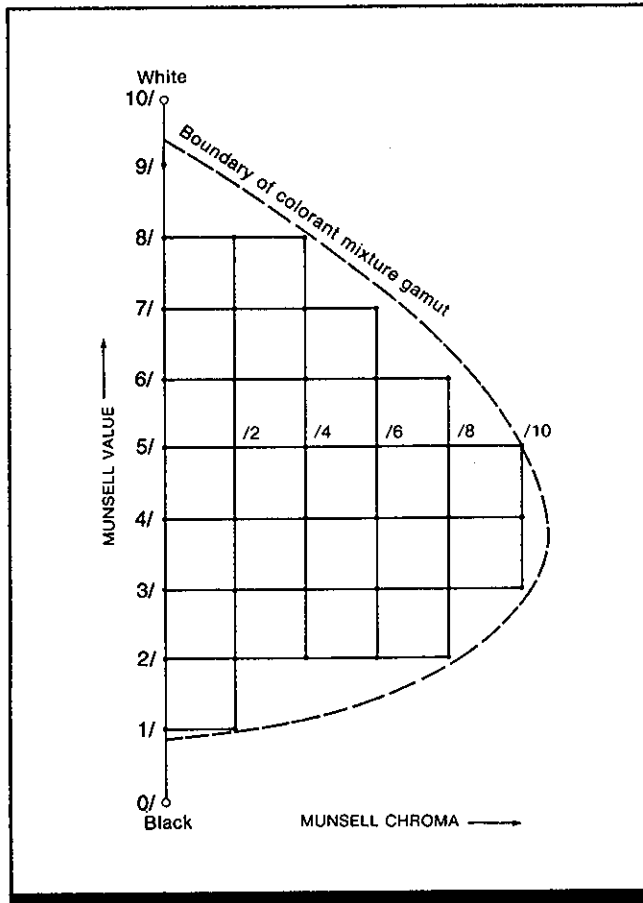

Figure 1. Organization of colors of constant Munsell hue in the Munsell Book of Color. (From Ref. 1)

Key Terms

Color appearance; color-order system; Munsell chroma; Munsell Color System; Munsell hue

General Description

Color appearance refers to that aspect of perception in which an observer is able to assign perceptual attributes such as hue, saturation, and brightness or lightness to a given visual target. The subject's judgment of the perceived color of a target results from the subjective impressions experienced when viewing the display. The Munsell Color System is the outstanding example of a color-order system (a rational method of ordering and specifying a set of object colors) based on the principles of color appearance.

In the Munsell Color System, material standards (color samples) are selected to represent subjective scales of constant hue, saturation, and lightness. Each sample color is spaced uniformly in accordance with the perceptions of an observer with normal color vision and is intended to be

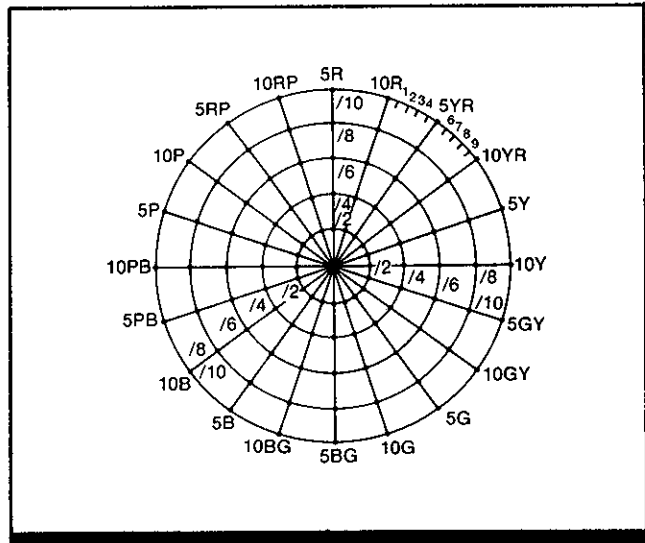

Figure 2. Organization of colors of constant Munsell value in the Munsell Book of Color. (From Ref. 1)

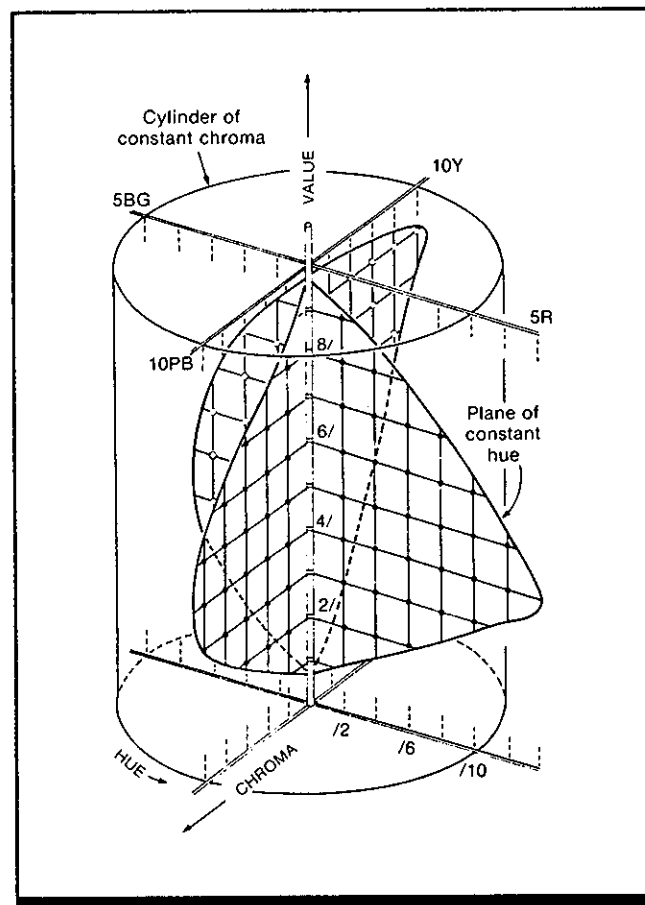

Figure 3. Schematic diagram of the Munsell color solid. (From Ref. 1)

viewed under standard viewing conditions. The system is embodied in the *Munsell Book of Color*, which is available through the Munsell Color Company and the Japan Color Research Institute. There are different editions of the book, each having different numbers of samples, different sample sizes, and different sample finishes (glossy or matte). The books consist of colored paint chips inserted into slots that are arranged in charts of constant hue, constant value, and constant chroma. The complete collection contains 1,225 different samples (paint chips).

Each chip is identified by three symbols: the first indicates *Munsell hue*, the second *Munsell value* (lightness), and the third, *Munsell chroma* (saturation). For example, the notation 2.5 YR 5/10 indicates a Munsell hue of 2.5 yellow-red, a Munsell value of 5/ (which is equally separated from black and white), and a Munsell chroma of /10 (10 steps away from gray of the same Munsell value).

The organization of a Munsell constant-hue chart is shown in Fig. 1. Samples in this chart have the same hue but vary in Munsell value and Munsell chroma. For the value scale, black is denoted by 0/ and white by 10/ with 9 grays placed uniformly in between. Colors of constant chroma are placed on the vertical lines parallel to the value scale, in increments of 2 from 0 (gray) to /10 (the maximum shown on this chart). The natural limit up to which chips can be produced by mixtures of chromatic pigments with black and white pigments is indicated in the figure by the dotted line which is the boundary of the colorant-mixture gamut. Different constant hue charts in the system have different gamuts. The size of the gamut and the shape of its boundary depend primarily upon the chromatic color used in the mixture, and is limited by available paints.

The organization of a Munsell constant-value chart, which is built from the constant-hue charts, is illustrated in Fig. 2. The 100-point Munsell hue scale and notation are shown on the outer circle. Colors of constant hue are shown by the radial lines, with the center being gray (chroma /0). The hue scale consists of 10 segments of 10 hues each, ranging from red (5R) to yellow (5Y), green (5G), blue-green (5BG), blue (5B), purple-blue (5PB), purple (5P), red-purple (5RP), and back to red (5R). The chroma scale is shown along the radial lines. It changes in increments of two from gray (0) at the center to the highest possible value on the chart (/10) at the outer circumference. Concentric circles are lines of constant Munsell chroma; radial lines are lines of constant Munsell hue. The *Munsell Book of Color* shows only 40 out of the 100 Munsell hues (i.e., 2.5, 5, 7.5, 10) on the constant-value charts. This organization has one defect, as does any radially organized system: the sampling of the color solid near the center is much denser than that of the high chroma colors represented toward the periphery.

The Munsell color solid, which is a cylindrical schematic of the overall system, is shown in Fig. 3.

A cross-section of the cylinder appears as the constant-value radial organization shown in Fig. 2, (only four planes of constant hue are shown, the 5R, 10PB, 5BG, and 10Y radials). The length of the cylinder under each radial is the constant-hue chart (Fig. 1) for that radial (hue). The center (vertical) axis of the cylinder is the Munsell value axis, which is the common axis for all planes of constant hues. The radius of the cylinder is determined by the constant chroma value (e.g., /10 for the cylinder in Fig. 3).

Applications

Selection of colors and color schemes, color matching, and color specification.

Constraints

- The samples in the *Munsell Book of Color* are designed for viewing under daylight (CIE standard illuminants C or D_{65}) and cannot be used as standards under other illuminants.

Key References

1. Judd, D. B., & Wyszecki, G. (1975). *Color in business, science, and industry* (3rd ed.). New York: Wiley.

Cross References

1.723 Color-order systems;
1.725 Color-order systems: Optical Society of America System;
Handbook of perception and human performance, Ch. 9, Sect. 7.1

1.725 Color-Order Systems: Optical Society of America System

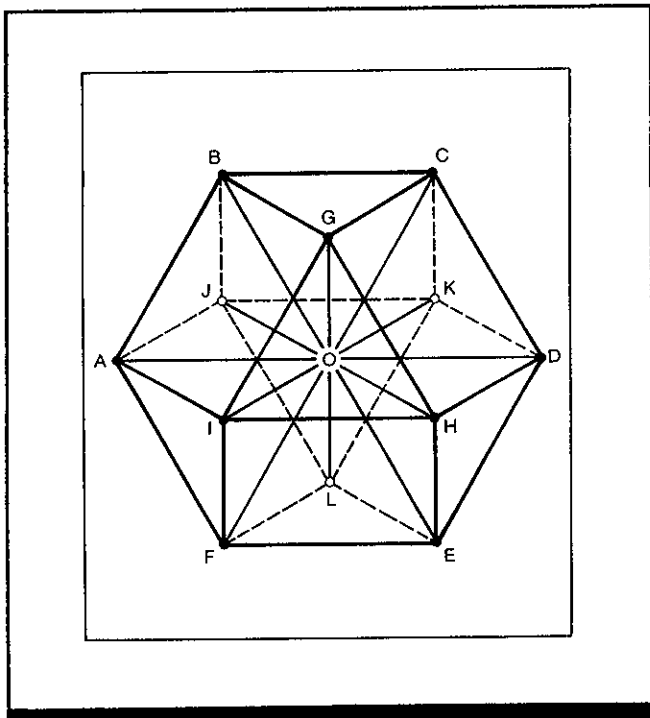

Figure 1. Cubo-octahedron used in OSA Color System. The twelve corners (colors A-K) are equidistant from the center (color 0). (From *Handbook of perception and human performance*)

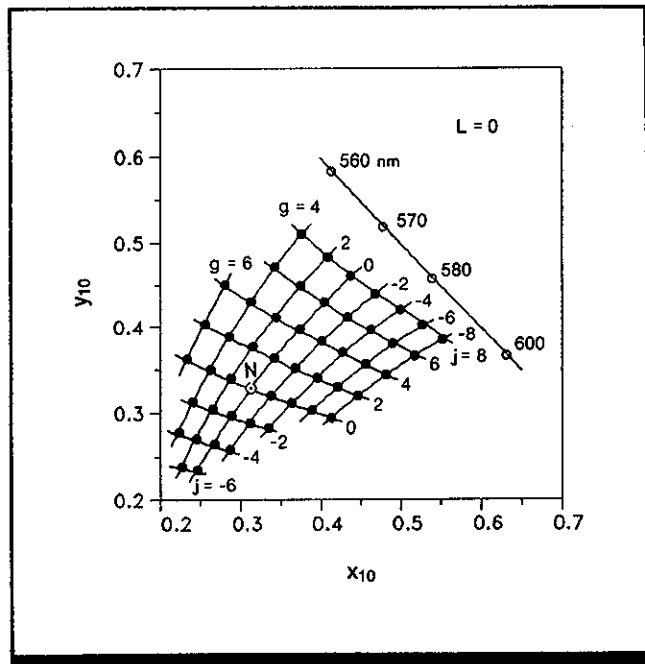

Figure 2. CIE 1964 (x_{10}, y_{10}) chromaticity diagram showing the square lattice of chromaticity points (j, g) of the colors of the OSA system for lightness level $L = 0$. The chromaticity point N is that of the nominal gray D_{65} in the system. (From Ref. 10)

Key Terms

Color Appearance; color-order system; OSA color system

General Description

The Optical Society of America (OSA) Color System is a three-dimensional color-order system based on the principles of color-appearance (i.e., observers' subjective judgments of perceived hue, **saturation**, and **brightness or lightness**). The system was developed by the Committee on Uniform Color Scales and is available from the Optical Society of America (Washington, DC). The system is advantageous when the colors being judged differ on the dimensions of lightness, hue, and chroma.

The system uses a regular rhombohedral lattice arrangement in three dimensions (a cubo-octahedron) to achieve uniform spacing of color samples that are perceptually equidistant from a central color (Fig. 1). Each color is surrounded by twelve equally distant neighbors. The rhombohedral lattice, which provides the most closely packed arrangement of colors, can be resolved into a series of seven parallel plane lattices using equilateral triangles and squares.

The system is available on color cards made with permanent glossy acrylic paints. There are 424 basic colors plus an addition 134 "half-step" intermediate samples in the near neutral region for a total of 558 colors. Each color (except those at the extremes) appears in six entirely different sets of equally spaced colors, with each set spanning the color solid. Two of the six sets show colors of equal lightness; the other four span light-to-dark colors and include variations in hue and saturation that are unlike those of any other color-order system (e.g., deep green to pastel greenish yellow to bright orange). It is possible to construct 422 scales of different colors that are visually equidistant from each other, with each scale composed of more than three colors. The paint chips are made to be viewed under daylight illumination (CIE standard illuminant D_{65}) on a middle-gray (30% reflectance) background. The colors in the system are specified in terms of the CIE 1964 (x_{10}, y_{10}, Y_{10}) coordinates for a 10-deg standard observer.

The three coordinates of the final color space are L (lightness), j (yellowness), and g (greenness). For planes of constant lightness, the representative arrangement is a lattice of squares. Lightness (L) ranges from -7 to $+5$. $L = 0$ indicates colors of medium lightness (the luminance factor $Y = 30$ background was used in the original judgments); negative values are darker, and positive values are lighter. A portion of the CIE 1964 (x_{10}, y_{10}) chromaticity diagram for $L = 0$ is shown in Fig. 2; Point N , where j and g are both zero, is a gray.

Positive values of j with zero values of g are yellow or brownish colors; negative j values and zero g values are blues; positive g values with zero j values are greens; negative g values with zero j values are reddish purples. Since colors of constant L are of constant perceived lightness, the luminance factor, Y , of such colors varies with chromatic-

ity, usually decreasing with distance from gray. The OSA Committee adopted the following formula:

$$L = (L' - 14.4)\sqrt{2}$$

where

$$L' = 5.9 [\bar{Y}_{10}]^{1/3} - 2/3 + 0.042 (\bar{Y}_{10} - 30)^{1/3}.$$

\bar{Y}_{10} is obtained from:

$$\bar{Y}_{10} = Y_{10} (4.4934 x_{10}^2 + 4.3034 y_{10}^2 - 4.276 x_{10} y_{10} - 1.3744 x_{10} - 2.5643 y_{10} + 1.8103).$$

The calculated \bar{Y}_{10} is the luminance of the gray sample that appears equally light as a given color sample. A perfect reflecting diffuser illuminated by the CIE standard D_{65} results in $Y_{10} = 100$ (white).

Applications

Selection of colors and color schemes, color matching, and color specification.

Constraints

- The color samples in the system are intended to be viewed under daylight illumination (CIE standard illuminant D_{65}) and against a gray background of 30% reflectance and cannot be used as standards under other viewing conditions.

Key References

1. Davidson, H. R. (1978). Preparation of the OSA Uniform Color Scales Committee samples. *Journal of the Optical Society of America*, 68, 1141-1142.
2. Foss, C. E. (1978). Space lattice used to sample the color space of the Committee on Uniform Color Scales of the Optical Society of America. *Journal of the Optical Society of America*, 68, 1616-1619.
3. MacAdam, D. L. (1974). Uniform color scales. *Journal of the Optical Society of America*, 64, 1691-1702.
4. MacAdam, D. L. (1978). Colorimetric data for samples of OSA uniform color scales. *Journal of the Optical Society of America*, 68, 121-130.
5. MacAdam, D. L. (1981). *Color measurement: Theme and variations*. New York: Springer Verlag.
6. Nickerson, D. (1975). Uniform color scales: Munsell conversion of OSA committee selection. *Journal of the Optical Society of America*, 65, 205-207.
7. Nickerson, D. (1977, Winter). History of the OSA Committee on Uniform Color Scales. *Optics News*, 3, 8-17.
8. Nickerson, D. (1978). Munsell renotation of samples of OSA uniform color scales. *Journal of the Optical Society of America*, 68, 1343-1347.
- *9. Wyszecki, G. (1986). Color appearance. In K. R. Boff, L. Kaufman, & J. P. Thomas (Eds.), *Handbook of perception and human performance: Vol. 1. Sensory processes and perception*. New York: Wiley.
10. Wyszecki, G., & Stiles, W. S. (1982). *Color science* (2nd ed.). New York: Wiley.

Cross References

- 1.723 Color-order systems;
- 1.724 Color-order systems: Munsell system

1.726 Congenital Color Defects

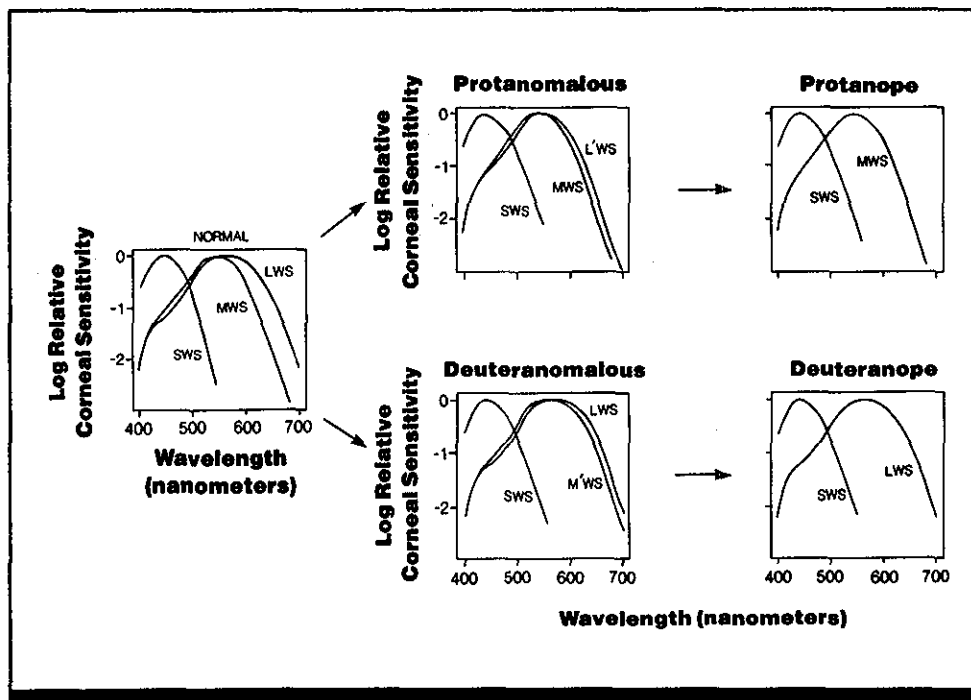

Figure 1. Log relative spectral sensitivities of the visual photopigments assumed to be active in normal trichromats and in anomalous trichromats and dichromats with red-green deficiencies. The normal photopigment absorption spectra are designated as LWS, MWS, and SWS, representing photopigments where maximal sensitivity occurs in the long-, middle-, and short-wavelength regions of the spectrum. Protanopes lack the long-wavelength system (LWS); protanomalous individuals are hypothesized to have the abnormal photo-pigment L'WS instead of the normal long-wavelength pigment. Likewise, deuteranomalous individuals display weakness in the medium-wavelength system (abnormal pigment M'WS), while deuteranopes lack the medium-wavelength system altogether. (From J. Pokorny & V. C. Smith, *New observations concerning red-green color defects*, *Color Research and Application*, 7. Copyright 1982 by John Wiley & Sons, Inc. Reprinted with permission)

Key Terms

Absorption defect; alteration defect; color blindness; color defect; deutan; deuteranomaly; deuteranopia; dichromacy; filtering defect; monochromacy; protan; protanomaly; protanopia; purity discrimination; reduction defect; trichromacy; tritan; tritanopia

General Description

Color-defective individuals show differences in color-matching and color-discrimination performance compared to those with normal color vision. Two ways to classify so-called "color blindness" are according to the presumed visual mechanism involved, and according to performance on visual tests. In reality, the term "color blindness" is poor because even individuals with the most severe form of color deficit (monochromacy) can discriminate among some colors, although they do so differently from those with normal color vision and can be deceived in their perception of colors. Further, many individuals with color deficits go

through adulthood unaware that they see colors differently from the way other people do. It is not uncommon for such individuals to insist that they have no deficits, even after tests indicate specific abnormalities.

The most common classification system for color deficits is based on performance on color matching tasks (CRef. 1.704). Normal color vision is called *trichromacy*, because any color in the spectrum can be matched by a mixture of no more than three primary colors (CRef. 1.702). Color-deficient observers require only two primaries for color matching (*dichromacy*), or even just one primary

(*monochromacy*) (i.e., any color can be matched by adjusting only the luminance of one primary color—hue differences are not seen). Color defects are usually subdivided into problems with red-green and violet-yellow discriminations.

The classification system becomes complex because trichromats and dichromats may share similar problems in dealing with colors in various regions of the visible spectrum. That is, a trichromat may be deficient in the ability to perceive long-wavelength lights, while a dichromat may be unable to perceive red at all. Such a trichromat is referred to as *protanomalous*; the dichromat is termed a *protanope*. Even though these observers fall into different categories, their perceptual performances are similar enough that they are collectively referred to as *protans*. Anomalous trichromats and dichromats who are deficient in perceiving medium-wavelength lights are called *deuteranomalous* individuals and *deuteranopes*, respectively; they are collectively identified as *deutans*. A third defect, the inability to perceive short-wavelength lights, occurs only in dichromacy and is called *tritanopia*. Anomalous trichromats and dichromats can be regarded as being able to see real colors, even though the colors they perceive would be subjectively different from those perceived by someone with normal trichromacy.

Some individuals show total color blindness, achromatopsia, or monochromacy. Two colored targets will be seen as identical by a monochromat if they show equal brightness. Thus, even people who are the most "color blind" can discriminate among some different colors on the basis of their brightnesses, context, and expectations. The incidence of the various color defects and the performance associated with these defects appear in Table 1.

Figure 1 shows the relative sensitivity of the various cone types in normal trichromats, anomalous trichromats, and dichromats to light of different wavelengths. Protanopes and protanomalous observers show similar contours, as do both types of deutans. Normal trichromats and tritans show best wavelength discrimination at about 590 nm, while protans and deutans are best at 490 nm and 495 nm, respectively. Further, there are individual differences on this measure. Likewise, worst **colorimetric purity** discrimination is at 570 nm for normal trichromats and tritans, but at 494 nm and 499 nm for deutans. These wavelengths are the neutral points for dichromats, i.e., the wavelengths are perceived as achromatic (without hue). The neutral point for tritans is at 570 nm. Normal trichromats see all such spectral points as having chromaticity, although the 570 nm point is the locus of worst purity discrimination for that group.

Protans and deutans do differ considerably, however, with respect to the wavelength seen as brightest with equal retinal illuminance. Normal trichromats and tritans show greatest **luminous efficiency** at about 555 nm, protans at 540 nm, and deutans at 560 nm. It has also been suggested that the luminous efficiency function of a protan, in addition

to being shifted toward the short-wavelength end of the spectrum, is also narrower, reflecting a markedly low efficiency at long wavelengths.

When the color confusions of a dichromat are plotted on a **chromaticity diagram**, the samples that are confused fall on straight lines that radiate from a single point, known as the copunctal point. Specified in terms of the CIE 1931 chromaticity diagram, the (x,y) -chromaticity coordinates for the copunctal point are (0.75, 0.24) for a protan, (1.40, -0.40) for a deutan, and (0.17, 0.00) for a tritan. These values vary considerably and will differ according to the individuals studied. The presence of these lines of confusion illustrates that even though an individual is classified as having, for example, "red-green color blindness," that person may have difficulty discriminating colors other than the two for which the defect is named.

When color defects are classified according to the mechanism of the deficiency, three types of color defect can be identified: absorption (or filtering) defects, alteration defects, and reduction defects. *Absorption defects* are color defects caused by abnormal filtering of light by ocular structures. The receptors (**rods** and **cones**) of such individuals are normal, and when the appropriate correction is made for the abnormal filtering (WDW normalization: CRef. 1.702) the color matches of these individuals agree with those of normal trichromats. *Alteration defects* occur when one or more of the visual pigments of the cones differ from those of normal trichromats; even with normalization, the color matches of individuals with alteration defects do not match those of normal trichromatic observers. Some color-defective observers accept all the color matches made by a color-normal observer, but accept additional matches as well. Such observers are said to suffer a *reduction defect*, which occurs when one of the normal receptor mechanisms is non-functional or when two receptor mechanisms are fused.

Congenital color defects are inherited. The most common are red-green defects. The recessive gene carrying these defects is sex-linked; thus, many more men than women suffer from such deficiencies. About 8-10% males and <1% of females show red-green color defects. Violet-yellow defects are much less common and do not appear to be sex-linked; estimates of the incidence of violet-yellow defects range from 1 in 1,000 to 1 in 65,000 of the population.

Typically, defects are assessed in detail by means of an anomaloscope, a viewing device which requires the observer to adjust one half of a split field to match a standard in the other half in a color matching task. Other screening tests are also available for the detection of color defects. They include relatively easy-to-use devices such as pseudo-isochromatic plates (which consist of printed dots forming different colored figure and ground configurations) and the Farnsworth-Munsell 100-Hue Test (colored paper chips arranged in order of hue by the normal subject).

Applications

Any task which requires an observer to make responses based on color distinctions will be affected by possible color defects that may go unnoticed in routine activity.

Table 1. Classes of congenital color defect, with performance characteristics and incidence in the population. (From Ref. 7)

Preferred Designation		Color Discriminations Possible*	Incidence in Population (percent)	
By Number of Components	By Type		Male	Female
Trichromatism (3) (normal or color weak)	Normal	L-D, Y-B, R-G	—	—
	Protanomaly	L-D, Y-B, weak R-G	1.0	0.02
	Deuteranomaly	L-D, Y-B, weak R-G	4.9	0.38
Dichromatism (2) (partial color blindness)	Protanopia	L-D, Y-B	1.0	0.02
	Deuteranopia	L-D, Y-B	1.1	0.01
	Tritanopia	L-D, R-G	0.002	0.001
Monochromatism (1) (total color blindness)	Congenital total color blindness	L-D	0.003	0.002

*L-D = Light-Dark

Y-B = Yellow-Blue

R-G = Red-Green

Constraints

• The color-matching performance of color-defective individuals depends on the size of the target field used in the matching task. For example, dichromatic observers become trichromatic when large field sizes are used (due to the contribution of rods or anomalous cones); most tritanopes show normal color matching for large fields.

- In addition to the absence of color vision, most monochromats show other disturbances of visual function, such as poor visual acuity and photophobia (intolerance of bright light).
- Color-vision defects may also be acquired through injury or disease.

Key References

1. Boynton, R. M. (1979). *Human color vision*. New York: Holt, Rinehart & Winston.
2. Breton, M. E., & Cowan, W. B. (1981). Deuteranomalous color matching in the deuteranopic eye. *Journal of the Optical Society of America*, 71, 1220-1223.
3. Farnsworth, D. (1947). *The Farnsworth dichotomous test for color blindness*. New York: Psychological Corporation.
4. Farrell, R. J., & Booth, J. M. (1984). *Design handbook for imagery interpretation equipment*. Seattle, WA: Boeing Aerospace Co.
5. Hsia, Y., & Graham, C. H. (1965). Color blindness. In C. H.

- Graham (Ed.), *Vision and visual perception*. New York: Wiley.
6. Hurvich, L. M. (1972). Color vision deficiencies. In D. Jameson & L. M. Hurvich (Eds.), *Handbook of sensory physiology: Vol. VIII/4. Visual psychophysics*, (pp. 582-625) Berlin: Springer-Verlag.
7. Judd, D. B., & Wyszecki, G. (1963). *Color in business, science, and industry*. New York: Wiley.
8. Nagy, A. L. (1980). Large-field substitution Rayleigh matches of dichromats. *Journal of the Optical Society of America*, 70, 159-164.
9. National Academy of Science—National Research Council Committee on Vision (1981). *Procedures for testing color vision*.

- Washington, DC: National Academy Press.
10. Pokorny, J., & Smith, V. C. (1982). New observations concerning red-green color defects. *Color Research and Applications*, 7, 159-164.
11. Pokorny, J., Smith, V. C., Verriest, G., & Pinckers, A. J. L. G. (1979). *Congenital and acquired color defects*. New York: Grune & Stratton.
12. Pokorny, J., Smith, V. C., & Went, L. N. (1981). Color matching in autosomal dominant tritan defect. *Journal of the Optical Society of America*, 71, 1327-1334.
13. Smith, V. C., & Pokorny, J. (1977). Large-field trichromacy in protanopes and deuteranopes.

- Journal of the Optical Society of America*, 67, 213-220.
14. van Heel, L., Went, L. M., & van Norren, D. (1980). Frequency of tritan disturbances in a population study. In G. Verriest (Ed.), *Colour vision deficiencies V*. Bristol, England: Hilger.
15. Wright, W. D. (1946). *Researches on normal and defective color vision*. London: Henry Kimpton.
16. Wright, W. D. (1952). The characteristics of tritanopia. *Journal of the Optical Society of America*, 42, 509-520.
17. Wyszecki, G., & Stiles, W. S. (1982). *Color Science: Concepts and Methods, Quantitative Data and Formulae* (2nd Ed.). New York: Wiley.

Cross References

- 1.109 Photometric techniques for measuring spectral sensitivity;
- 1.702 Color mixture and color matching;
- 1.704 Chromaticity discrimination

Section 1.8 Binocular Vision

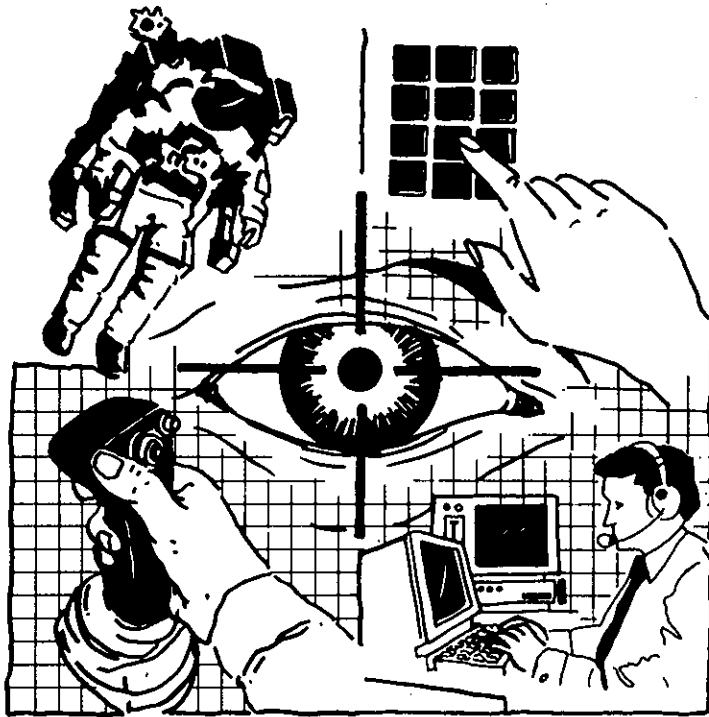

1.801 Advantage of Binocular over Monocular Vision

Key Terms

Binocular enhancement; binocular interaction; binocular summation; binocular viewing; monocular viewing; neural summation

General Description

In addition to the fact that **binocular** vision affords us the advantage of **stereopsis**, many visual tasks can be performed better with two eyes than with one. Binocular viewing conditions produce superior:

- Visual detection at threshold, including absolute light detection and contrast sensitivity
- Visual acuity, as assessed by **Snellen letters**, **Landolt rings**, and the high spatial frequency range of the contrast sensitivity function (CRef. 1.802)
- Form recognition, especially in simple displays
- Reaction time to onset of light flashes and bar patterns (**sine-wave gratings**).

There are two possible sources of this binocular advantage. The first, *probability summation* between the eyes, is due to each eye's independent chance of detecting a stimulus, which engenders better overall performance than if only a single eye is tested (CRef. 1.814). The concept of binocular probability summation implies that independent detection decisions can be made monocularly before the observer makes the overall decision response (CRef. *Handbook*).

The second possible source of binocular advantage is

neural summation. This refers to the actual convergence of **monocular** neural pathways to produce a physiological "sum" (which here means greater than monocular activity but less than or equal to the arithmetic sum of monocular activities).

When binocular performance is found to be better than monocular, it is difficult to separate the relative contributions of probability summation and neural summation. Usually one adopts a particular model of probability summation, attributes to it whatever its predictions can account for, and attributes the excess to neural summation. It is also possible to empirically estimate the effects of probability summation by measuring performance under conditions which simulate the independent decisions of the two eyes. For example, Ref. 3 employed two methods to estimate probability effects using a single eye: giving the eye two simultaneous chances to detect, but presenting the stimulus to widely separated retinal locations; and giving the eye two nonsimultaneous chances to detect at the same retinal location. These provided an empirical probability summation baseline. Binocular performance was even better than that predicted by the empirical baseline, providing evidence for neural summation.

Applications

Stereoscopic, autostereoscopic, and volumetric display designs, especially those in which detection of a target is critical.

Key References

1. Blake, R., & Fox, R. (1973). The psychophysical inquiry into binocular summation. *Perception & Psychophysics*, 14, 161-185.

2. Blake, R., Sloane, M., & Fox, R. (1981). Further developments in binocular summation. *Perception & Psychophysics*, 30, 266-276.

3. Thorn, F., & Boynton, R. M. (1974). Human binocular summation at absolute threshold. *Vision Research*, 14, 445-458.

Cross References

1.802 Monocular versus binocular contrast sensitivity;

1.803 Binocular combination of brightness and contrast;

1.814 Probability summation; *Handbook of perception and human performance*, Ch. 23, Sect. 1.1

Notes

✓

✓

✓

✓

1.802 Monocular Versus Binocular Contrast Sensitivity

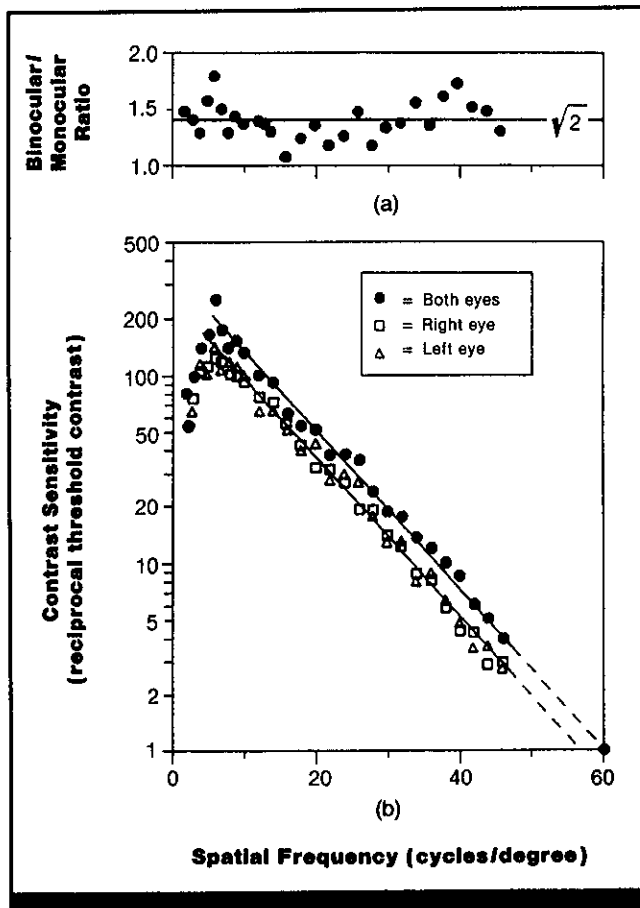

Figure 1. (a) Ratio of binocular to mean monocular sensitivity and (b) binocular versus monocular contrast sensitivity. Note logarithmic axis. (From Ref. 3)

Key Terms

Binocular summation; binocular viewing; contrast sensitivity; contrast summation; monocular viewing

General Description

Sensitivity to low luminance contrast is greater under binocular than under monocular viewing conditions.

Applications

Stereoscopic or autostereoscopic display designs under low luminance or low contrast viewing conditions.

Methods

Test Conditions

- Sine-wave grating patterns viewed on a CRT raster display; luminance across screen varied sinusoidally for variable number of cycles; constant average overall luminance across screen of 80 cd/m²
- Display adjustable independently

in contrast and spatial frequency (number of cycles per degree of visual angle)

- Grating filled rectangular area subtending 2 × 1.3 deg surrounded by 12-deg circular field; viewed at 144.8 cm (57 in.)
- Eyes corrected to within 0.12 diopter with spectacle lenses; 2.8-mm artificial pupils,

eyes treated with atropine to fix accommodation

- Other eye viewed frosted glass during monocular viewing

Experimental Procedure

- Method of adjustment
- Independent variable: luminance contrast
- Dependent variable: contrast

sensitivity, or the reciprocal of threshold contrast; contrast (modulation contrast) is defined as (max luminance - min luminance)/(max luminance + min luminance)

- Observer's task: set contrast so pattern was just visible
- Two trials per data point
- 2 observers, practiced

Experimental Results

- In every case, binocular contrast sensitivity is higher than the monocular contrast sensitivity of either eye alone.
- Ratio of binocular to mean monocular sensitivity, shown in Fig. 1a, is $\sim\sqrt{2}$ for all spatial frequencies.
- Extrapolating curves to highest visible spatial frequency indicates a binocular improvement in grating acuity of $\sim 40\%$ (curves in Fig. 1b fit by eye).
- 2 observers tested with natural pupils and normal accommodation gave similar results.

Variability

The mean ratio of binocular to monocular sensitivities was 1.42 for the three experiments with 2 observers. The standard error (SE) about that mean was 0.021. Individual SEs for the same ratio ranged from 0.021 - 0.045.

Repeatability/Comparison with Other Studies

Ratio of binocular to monocular sensitivity of $\sim\sqrt{2}$ is similar to most studies, despite differences in absolute sensitivity and method of measurement.

Constraints

- Binocular enhancement seems to exist only when the gratings in the two eyes are within 1/2 octave in spatial frequency, are flickering at the same temporal frequency, are

within ± 15 deg in orientation, and are moving in the same direction.

- Many factors affect contrast sensitivity and must be considered in applying these results under different conditions (CRef. 1.628).

Key References

1. Arditi, A., Anderson, P., & Movshon, J. A. (1981). Monocular and binocular detection of moving sinusoidal gratings. *Vision Research*, 21, 329-336.

2. Blake, R., & Levinson, E. (1977). Spatial properties of binocular neurons in the human visual system. *Experimental Brain Research*, 27, 221-232.

*3. Campbell, F. W., & Green, D. G. (1965). Monocular versus binocular visual acuity. *Nature*, 208, 191-192.

Cross References

1.628 Factors affecting contrast sensitivity for spatial patterns;
1.801 Advantage of binocular over monocular vision;

1.803 Binocular combination of brightness and contrast;
Handbook of perception and human performance, Ch. 23, Sect. 1.2

1.803 Binocular Combination of Brightness and Contrast

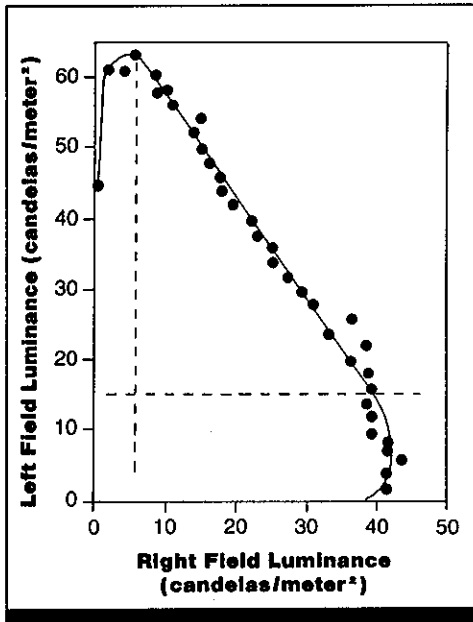

Figure 1. Binocular equal brightness contour. The figure shows, for a given right- or left-eye luminance, the luminance required in the other eye for the binocular combination to appear equal in brightness to a standard luminance 30 cd/m². Dotted lines demarcate the portion of the curve over which binocular brightness averaging holds. The nonlinear tails of the curve show regions where brightness averaging fails and binocular brightness is determined primarily by the luminance of the brighter eye. (From Ref. 5)

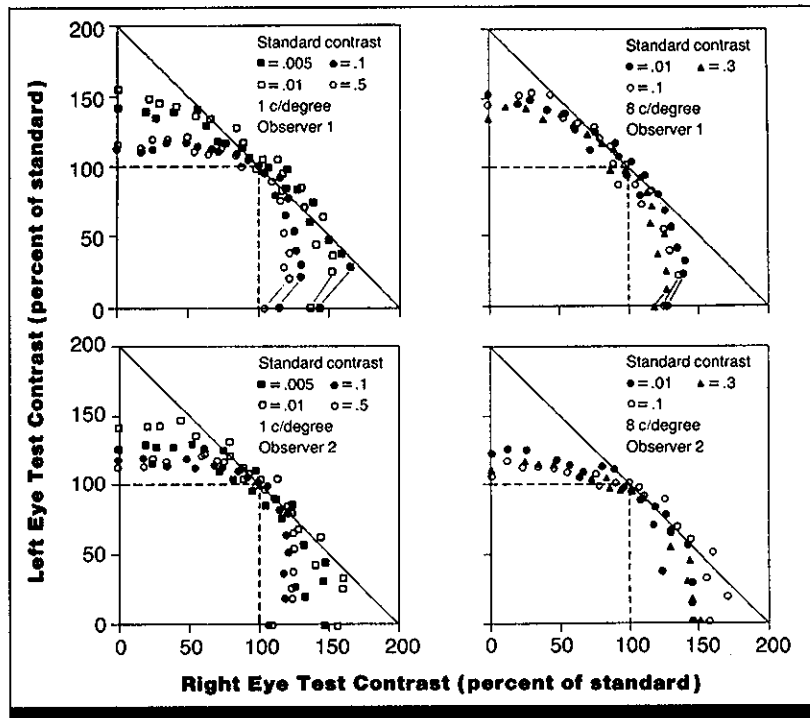

Figure 2. Binocular equal contrast curves. Figure shows, for given right- or left-eye contrast, the contrast required in the other eye for the combination to appear equal in brightness to a standard of the indicated contrast. Left panels show equal contrast functions for bar patterns of 1 cycle/deg; right panels, for bar patterns of 8 cycles/deg (1 cycle = 2 times width of individual bar). Negative diagonal line represents values for simple binocular averaging of monocular contrasts; horizontal and vertical lines at 100% contrast represent binocular contrast determined solely by the greater monocular contrast. Measured binocular contrasts fall in between two theoretical curves, indicating that some binocular averaging occurs, but higher weight is given to the greater of the monocular contrasts. (From Ref. 4)

Key Terms

Binocular averaging; binocular summation; brightness; contrast; Fechner's paradox

General Description

In general, the brightness of a binocular visual scene is the average of the brightness of the left eye's view and the brightness of the right eye's view. Thus, when the luminance in one eye is attenuated relative to the luminance in the other eye, the brightness of the visual scene may be greater with the dimmer eye closed than with both eyes open, even though less total light reaches the visual system. This phenomenon is known as *Fechner's paradox*. When the luminances of the two eyes' fields are very different,

however, binocular brightness depends more on the luminance of the brighter eye and may be greater than the average of the two half-fields.

Binocular contrast combination shows a different pattern from binocular brightness combination. The apparent contrast of a binocular pattern is greater than the average of the contrasts in the right and left eyes, but is less than the contrast of the higher-contrast eye; that is, binocular contrast is determined more strongly, but not wholly, by the greater of the monocular contrasts.

Methods

Test Conditions

Binocular brightness combination (Ref. 5)

- Two circular targets 3 deg of visual angle in diameter, viewed against black background
- Luminance of standard target 30 cd/m² in both eyes; luminance of test target fixed in one eye, variable in other
- Standard target and test target presented simultaneously

Binocular contrast combination (Ref. 4)

- Vertical sine wave grating presented via CRT; spatial frequency

- 1 or 8 cycle/deg; constant mean luminance 10 cd/m²; dark surround
- Contrast of standard bar pattern equal in both eyes; contrast levels were .005, .01, .1, .3, .5 where contrast = (max luminance - min luminance)/(max luminance + min luminance)
- Contrast of test bar pattern different in each eye; contrast variable, but right/left contrast ratio held constant at one of several values
- Standard pattern and test pattern viewed sequentially; 180 msec presentation per pattern, 600 msec between patterns; standard and test patterns continued to alternate until match made by observer

Experimental Procedure

Binocular brightness combination

- Method of adjustment, under observer's control
- Independent variable: luminance of test target in fixed-luminance eye
- Dependent variable: luminance setting of test target in variable-luminance eye needed to match standard target
- Observer's task: adjust target luminance in variable-luminance eye until brightness of test target matched brightness of standard target
- Data shown for 1 observer

Binocular contrast combination

- Method of adjustment, under observer's control
- Independent variables: contrast of standard pattern, left/right contrast ratio of test pattern, spatial frequency
- Dependent variable: contrast of test pattern needed to match contrast of standard
- Observer's task: adjust contrast of test pattern to match contrast of standard
- Eight settings per point
- 6 observers; data are plotted for 2 observers at each spatial frequency

Experimental Results

- For brightness matching (Fig. 1), when the difference between left and right eye luminances is not great, perceived binocular brightness is the average of the monocular brightnesses (matches fall on straight line with slope of -1).
- When the two eyes receive very different luminances, as the luminance ratio between the eyes is increased beyond some value (points of inflection on equal brightness contour in Fig. 1), binocular brightness increases, so that the total of the monocular luminances required to match the standard target is smaller than elsewhere along the curve.
- When only one eye receives the test target and the other views a dark background, the binocular percept is less bright than if both eyes see the target, since the luminance of the eye viewing the target must be made higher than the luminance of the standard to match it in brightness.

- For contrast matching, perceived binocular contrast is determined more strongly, but not wholly, by the greater of the two monocular contrasts (Fig. 2).

- Binocular contrast combination is similar for coarse (1 cycle/deg) and finer (8 cycles/deg) bar patterns.

Variability

No information on variability was given.

Repeatability/Comparison with Other Studies

Other investigators have found some binocular brightness summation (binocular brightness is slightly greater than the brighter monocular stimulus) when monocular brightness differences are small (Refs. 2, 3). Results for binocular contrast combination are consistent with those of other studies.

Constraints

- Many individuals show eye dominance effects in which the inputs of the right and left eyes contribute unequally to the binocular percept. Such eye dominance is evident in the

binocular luminance matching function by departure of the equal brightness contour from a slope of -1 and in binocular contrast functions by asymmetrical tilt of equal contrast curves with respect to the diagonal.

Key References

1. Curtis, D. W., & Rule, S. J. (1980). Fechner's paradox reflects a nonmonotone relation between binocular brightness and luminance. *Perception & Psychophysics*, 27, 263-266.

2. Da Silva, H. R., & Bartley, S. H. (1930). Summation and subtraction of brightness in binocular perception. *British Journal of Psychology*, 20, 242-252.

3. Engel, G. R. (1967). The visual process underlying binocular brightness summation. *Vision Research*, 7, 753-767.

*4. Legge, G. E., & Rubin, G. S. (1981). Binocular interactions in

suprathreshold contrast perception. *Perception & Psychophysics*, 28, 49-61.

*5. Levelt, W. J. M. (1968). *On binocular rivalry*. The Hague: Mouton.

Cross References

1.801 Advantage of binocular over monocular vision;

1.802 Monocular versus binocular contrast sensitivity

1.804 Binocular Suppression and Rivalry

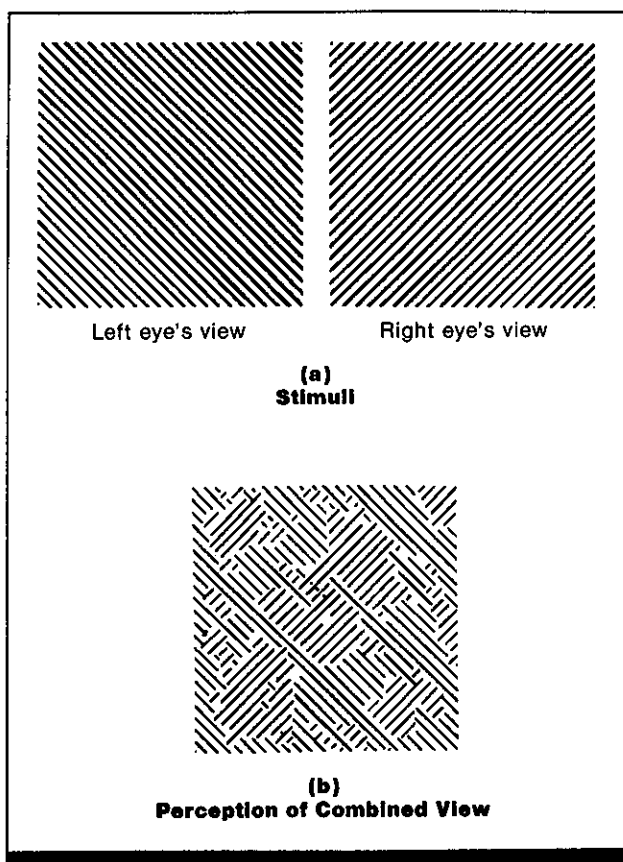

Figure 1. (a) Stereogram composed of orthogonally oriented lines in the two half-fields, to determine binocular suppression and rivalry; (b) Binocular appearance of (a) when half-fields are $> \sim 1$ deg. (From *Handbook of perception and human performance*)

Key Terms

Binocular rivalry; binocular suppression; image prevalence; retinal rivalry; single vision

General Description

Binocular suppression is the decrease or loss of visibility of a portion (or all of) one eye's view due to stimulation of the same visual field location of the other eye. A simple demonstration of such suppression can be had by viewing a stereogram which has grossly conflicting information in the two half-fields, such as the one shown in Fig. 1a. In such situations of conflict, the eyes usually engage in *retinal rivalry*, in which the suppressed (unseen) and dominant (visible) half-fields alternate in 1-4 sec time periods. Suppression may also be piecemeal, and appear as in Fig. 1b, where each eye contributes dominant portions to the combined percept. Part of the time, only one pattern will be seen; part of the time only the other; and part of the time a mixture, as shown. This figure, however, illustrates only an instant of the stereogram's appearance, since the dominance and suppression of each portion are in a constant state of flux. Piecemeal suppression tends to occur with patterns subtending more than ~ 1 deg arc of visual angle.

Very different orientations of contours in the two half-fields (i.e., to the two eyes) are not the only conditions which produce suppression rivalry. Nearly any difference that might be produced by different objects imaged on corresponding portions of the retinas will produce rivalry. Placing a hand in front of one eye and viewing a distant object illustrates suppression. Although one is aware of the hand, one can also see through it to the environment beyond. Other conditions which produce suppression rivalry include differences in contour length, size, brightness, and hue. Even targets of equal luminance, if made to appear very different in intensity (lightness) or hue through **simultaneous contrast**, may produce rivalry. When targets whose contours are identical but differ in other ways (such as hue), the binocular image takes on a lustrous appearance, dynamically changing the appearance of local regions of the target over time.

Applications

Stereoscopic and autostereoscopic displays in which left and right eyes, or portions thereof are stimulated with grossly conflicting information.

Constraints

- Suppression and rivalry may also occur with identical visual stimulation in both eyes, and hence be ubiquitous. There is as yet no way to determine this, since there is no

way to identify the eye of origin of the percept.

- Under highly specific conditions, such as long exposure time, equal luminance, and uniform surround, lights of similar wavelength may mix rather than rival (Ref. 3).

Key References

1. Kaufman, L. (1974). *Sight and mind*. New York: Oxford University Press.
2. Levelt, W. J. M. (1968). *On binocular rivalry*. The Hague: Mouton.
3. Thomas, F. H., Dommick, F. L., & Luria, S. M. (1961). A study of binocular color mixture. *Vision Research, 1*, 108-120.
4. Wallach, H., & Adams, P. A. (1954). Binocular rivalry of achromatic colors. *American Journal of Psychology, 67*, 513-516.

Cross References

- 1.805 Spatial extent of binocular suppression;
 - 1.806 Time course of binocular suppression and rivalry;
 - 1.807 Visual sensitivity and performance during binocular suppression;
- Handbook of perception and human performance*, Ch. 23, Sect. 2.

1.805 Spatial Extent of Binocular Suppression

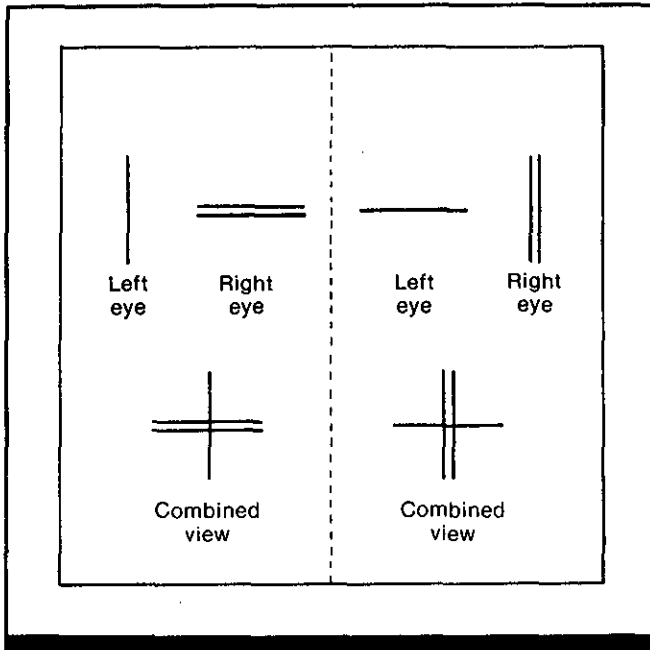

Figure 1. Target configurations presented stereoscopically. Combined view illustrates percept in the absence of suppression; when suppression occurs, portion of single line which falls between the two parallel lines is not visible. (From Ref. 1)

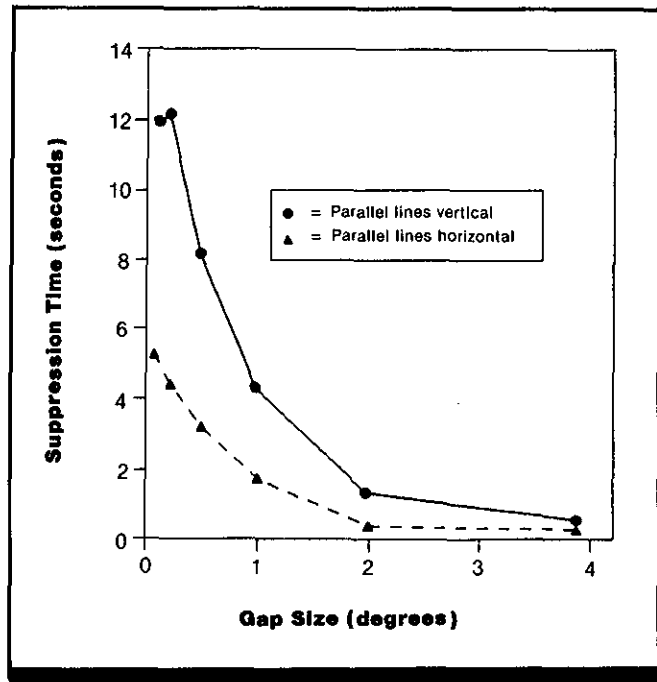

Figure 2. Spread of suppression for line patterns shown in Figure 1. The graph shows the mean length of time within 30-sec trials that the portion of the cross bar falling between the two parallel lines was suppressed (not visible) as a function of the distance between the parallel lines. (From Ref. 1)

Key Terms

Binocular rivalry; binocular suppression; image prevalence; retinal rivalry; single vision

General Description

When the visual patterns presented to the left and right eyes are not identical, part or all of one eye's pattern may be suppressed, i.e., may drop from visibility (CRef. 1.804).

Monocular contours carry into the binocular view zones

of suppression which define the smallest possible regions which can be suppressed. The measured spread of suppression is ~1 deg arc of visual angle and is greater in the horizontal than in the vertical dimension.

Applications

Stereoscopic and autostereoscopic displays in which contours of different orientation are presented to the two eyes. Viewing a monocular display with one eye while simultaneously viewing the world with the other eye. Optically displayed visual field with spatially distributed distortion.

Methods

Test Conditions

- Targets were one single vertical and two horizontal lines, or two vertical and one horizontal line; Fig. 1 shows configurations and combined views assuming no suppression

- Targets drawn with a hard pencil on white cards viewed in a stereoscope
- Separation between lines: ~0.125, 0.25, 0.5, 1, 2 and 4 deg of visual angle

Experimental Procedure

- Independent variable: angular separation between lines of the two-line half-fields (gap size); horizontal or vertical parallel lines
- Dependent variable: mean (complete) suppression times per 30-sec trial

- Observer's task: register left and right half-fields binocularly and press a button when single line completely disappeared from region between two lines of other half-field
- Four 30-sec trials per data point
- 10 naïve observers

Experimental Results

- In line patterns such as those in Fig. 1, as the gap between parallel lines decreases, the duration of suppression of the portion of the single line that falls within the gap increases monotonically.
- Suppression reaches a maximum of ~ 14 min arc, beyond which further decreases in gap size do not result in greater suppression time.
- Suppression in a horizontal direction (parallel lines verti-

cal) is significantly greater than vertical suppression for all but largest two gap sizes ($p < 0.025$). Frequency of suppression (not shown) showed similar results.

- Other experiments (Ref. 1) indicate that the greater horizontal extent of suppression is due to greater instability of convergence eye movements than vertical eye movements.

Variability

One-tailed t -tests used to test significance; no specific information on variability given.

Constraints

- The spatial extent of suppression may vary with other parameters as well, such as contrast and spectral content of the target.
 - The spatial extent of suppression may also fluctuate over time, to some degree, within rivalry phases.
-

Key References

*1. Kaufman, L., (1963). On the spread of suppression and binocular rivalry. *Vision Research*, 3, 401-415.

2. Kaufman, L., (1974). *Sight and mind*. New York: Oxford University Press.

Cross References

1.804 Binocular suppression and rivalry;

1.806 Time course of binocular suppression and rivalry;

1.807 Visual sensitivity and performance during binocular suppression;

Handbook of perception and human performance, Ch. 23, Sect. 2.3

1.806 Time Course of Binocular Suppression and Rivalry

Table 1. Variables Affecting Binocular Rivalry and Suppression.

Variable	Effect on Alternation Rate	Effect on Image Prevalence	Effect on Suppression Duration	References
Field Luminance (one eye)		+		Ref. 2
Field Luminance (both eyes)	+			Ref. 2
Contrast		+	-	Ref. 2, 5, 6
Field area (both eyes)	+			Ref. 2
Amount of "contour" (one eye)		+		Ref. 1, 2, 6
Field motion (one eye)		+		Ref. 2
Blur of pattern (both eyes)	-			Ref. 2
Target distance from fixation (both eyes)	-			Ref. 2

Key Terms

Binocular rivalry; binocular suppression; image prevalence; retinal rivalry; single vision

General Description

When visual patterns presented to the right and left eyes are not identical, an observer may experience *binocular rivalry* (CRef. 1.804), in which some or all of one eye's view is suppressed and the visible half-field alternates from eye to eye over time. If the pattern to each eye is appropriately structured (e.g., vertical lines in one eye, horizontal lines in the other) the observer can identify which half-image is visible and can track shifts in the perceived image from eye to eye. Three measures of interest are the alternation rate (the rate at which the predominant view shifts from eye to eye), image prevalence (the proportion of time a given eye's view is predominant), and average duration of suppression (the average time the other eye's view is visible). (Note that the

duration of suppression will vary with both image prevalence of the other eye and alternation rate.)

Table 1 lists variables known to affect these three aspects of binocular rivalry and suppression and indicates the direction of the effect. A plus sign indicates that increasing the variable increases the value of the indicated measure; a minus sign indicates that increasing the variable decreases the value of the measure. Note that each variable can be increased in one or both eyes. For cases where the value of a variable is changed in one eye only, the effect indicated is for that eye. An empty cell indicates that the effect of the variable on the given measure is not known. Reference 6 contains a review of virtually all studies of binocular rivalry prior to 1965.

Applications

Stereoscopic and autostereoscopic displays in which the information simultaneously presented to the two eyes is not identical.

Constraints

- Duration of suppression may be affected by other variables not listed here.
- Studies showing that field luminance increases image prevalence have confounded luminance with contrast; other studies have found no effect of field luminance.

Key References

1. Alexander, L. T. (1951). The influence of figure-ground relationships in binocular rivalry. *Journal of Experimental Psychology*, 41, 376-381.
2. Blake, R. (1977). Threshold conditions for binocular rivalry. *Journal of Experimental Psychology: Human Perception and Performance*, 3, 251-257.
3. Breese, B. B. (1899). On inhibition. *Psychological Monographs*, 3, (1, Whole No. 11).
4. Fox, R., & Rasche, F. (1969). Binocular rivalry and reciprocal inhibition. *Perception & Psychophysics*, 5, 215-217.
5. Kakizaki, S. (1960). Binocular rivalry and stimulus intensity. *Japanese Psychological Research*, 2, 94-105.
6. Levelt, W. J. M. (1968). *On binocular rivalry*. The Hague: Mouton.

Cross References

- 1.804 Binocular suppression and rivalry;
- 1.805 Spatial extent of binocular suppression;
- 1.807 Visual sensitivity and performance during binocular suppression

1.807 Visual Sensitivity and Performance During Binocular Suppression

Table 1. Effect of Binocular Suppression on Visual Performance

Visual Task	Sensitivity or Performance Change	References
Detection of test flashes	Threshold in suppressed condition higher by 0.5 log unit	Refs. 1,9,10
Detection of contrast decrements	Changes detected almost immediately in suppressed condition	Ref. 2
Detection of contrast decrements	Changes detected only after altered target returns to dominant phase	Ref. 2
	Introduction of contrast decrement reduces duration of suppression phase	Ref. 11
Detection of changes in spatial frequency	Changes detected only after altered target returns to dominant phase	Ref. 2
	Introduction of spatial frequency changes reduces duration of suppression phase	Ref. 11
Detection of changes in orientation	Changes detected only after altered target returns to dominant phase	Ref. 2
	Introduction of change in orientation reduces duration of suppression phase	Ref. 11
Latency for detecting onset of motion	Reaction time to movement is significantly increased during suppression; the magnitude of the increase is inversely related to the strength of the movement stimulus	Ref. 6
Letter recognition	Letter recognition is significantly lower (by 20%) for letters presented during suppression	Refs. 5, 7

Key Terms

Binocular rivalry; binocular suppression; letter recognition; motion detection; retinal rivalry; spatial frequency discrimination; spatial orientation discrimination; target detection

General Description

When the visual stimuli to the right and left eyes are not identical, part or all of the image of one eye may be suppressed, that is, the visibility of one eye's image may be reduced (CRef. 1.804). Usually the dominant (unsuppressed) image alternates from eye to eye over time—a phenomenon known as *binocular rivalry*. Performance on many visual tasks has been found to decline when the eye is in a state of suppression. This decline is measured by comparing sensi-

tivity to a target under **monocular** viewing, or when the eye is in a dominant phase, with sensitivity when the same eye is in a suppression phase under **binocular** rivalry conditions.

Table 1 lists some of the visual tasks on which performance or sensitivity decreases during suppression, describes the observed differences between the suppressed and dominant or monocular conditions, and cites sources of additional information.

Applications

Stereoscopic and autostereoscopic displays in which the information simultaneously presented to the two eyes is not identical.

Constraints

- Suppression affects a retinal area as a whole, rather than any specific set of target dimensions.

Key References

1. Blake, R., & Camisa, J. C. (1979). On the inhibitory nature of binocular rivalry suppression. *Journal of Experimental Psychology: Human Perception and Performance*, 5, 315-323.
2. Blake, R., & Fox, R. (1974). Binocular rivalry suppression: Insensitive to spatial frequency and orientation change. *Vision Research*, 14, 687-692.
3. Blake, R., Westendorf, D. H., & Overton, R. (1980). What is suppressed during binocular rivalry? *Perception*, 9, 223-231.
4. Breese, B. B. (1909). Binocular rivalry. *Psychological Review*, 16, 410-415.
5. Collyer, G., & Bevan, W. (1970). Objective measurement of dominance control in binocular rivalry. *Perception & Psychophysics*, 8, 437-438.
6. Fox, R., & Check, R. (1968). Detection of motion during binocular rivalry suppression. *Journal of Experimental Psychology*, 78, 388-395.
7. Fox, R., & Check, R. (1966). Forced-choice recognition during binocular rivalry suppression. *Psychonomic Science*, 6, 471-472.
8. Makous, W., & Pulos, E. (1981). Grating colors mix while their contours rival. *Visual Science Supplement*, 20, 225.
9. Makous, W., & Sanders, K. (1978). Suppressive interactions between fused patterns. In J. C. Armington, J. Krauskopf, & B. R. Wooten (Eds.), *Visual psychophysics and physiology. A volume dedicated to Lorrin Riggs*. New York: Academic Press.
10. Wales, R., & Fox, R. (1970). Increment detection thresholds during binocular rivalry suppression. *Perception & Psychophysics*, 8, 90-94.
11. Walker, P., & Powell, D. J. (1979). The sensitivity of binocular rivalry to changes in the nondominant stimulus. *Vision Research*, 19, 247-249.

Cross References

- 1.804 Binocular suppression and rivalry;
- 1.805 Spatial extent of binocular suppression;
- 1.806 Time course of binocular suppression and rivalry

1.808 Convergence Angle

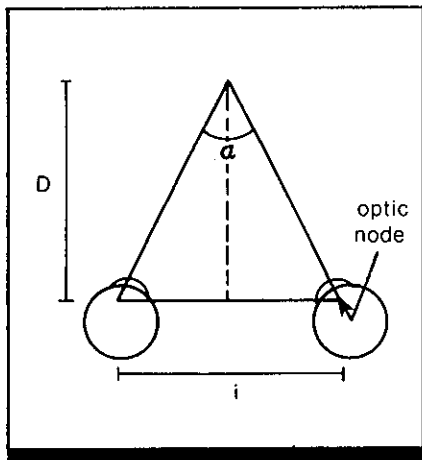

Figure 1. Symmetric convergence.

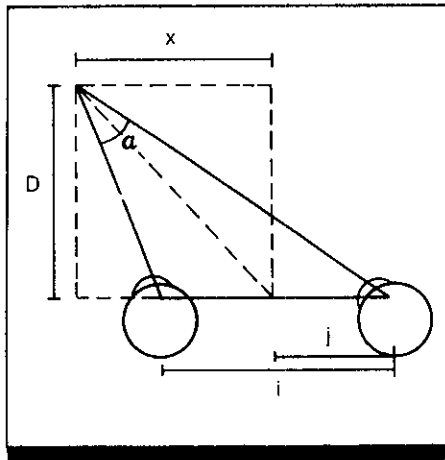

Figure 2. Asymmetric convergence.

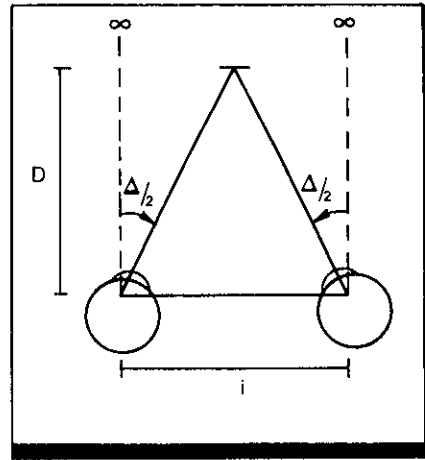

Figure 3. Convergence in diopters.

Key Terms

Binocular fixation; convergence; divergence; eye movements; vergence eye movements

General Description

Vergence is the rotation of the eyes inward or outward so that the lines of sight intersect at roughly the distance of the object being viewed; this allows the separate retinal images of the object to be seen as single or fused, and brings the images of the object into the central **foveas** of each eye, where acuity is greatest. *Convergence* is the movement of the eyes to focus on a point nearer the observer; *divergence* is movement to focus on a point further away.

Measurement of Convergence Angle

The convergence angle a is the angle formed between the lines of sight when the two eyes are fixated on a point in space (Fig. 1). The magnitude of a varies with fixation distance and **interpupillary distance (IPD)**.

The value of a in angular units (degrees or radians) is derivable from the geometry of target fixation by the eyes. Convergence can also be measured in **diopters**, linear units expressing the amount by which the eyes must rotate from parallel to fixate a target at a given distance (Fig. 3).

Table 1 shows how to determine the value of a in angular units for both *symmetric convergence* (fixation on a point directly ahead of observer) (Fig. 1) and *asymmetric convergence* (fixation displaced to one side) (Fig. 2). When a is small, and when the displacement of fixation from straight ahead is not too great, the simplified calculation formulas of Eqs. 3 and 4 in Table 1 provide reasonable approximations to a (the errors introduced by these simplifica-

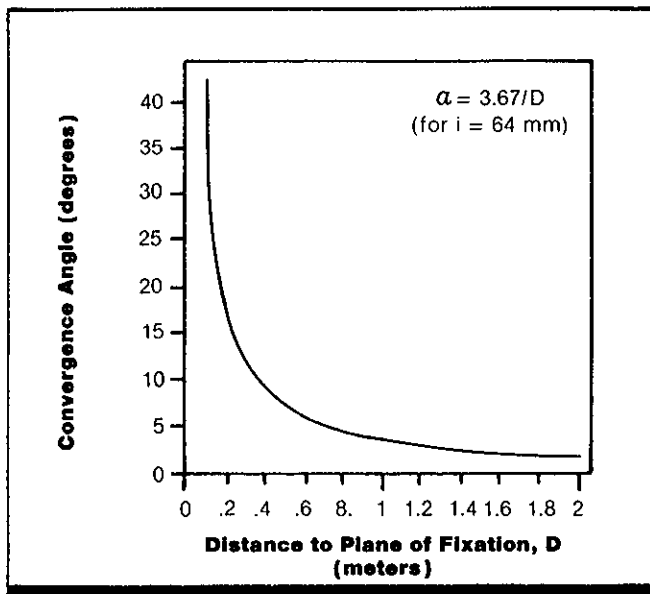

Figure 4. Convergence angle as a function of fixation distance.

tions are also given in the table). Convergence in diopters (Δ) is given by Eq. 5 of Table 1. Convergence in diopters and angular convergence are related as $a_{\text{rad}} = \Delta/100$.

Relation of Convergence Angle to Fixation Distance

Figure 4 shows how a varies with fixation distance for symmetric fixation. a decreases rapidly for distances ~ 1 m from observer, but changes only slightly beyond 2 m.

Table 1. Calculation of convergence angle.

In Angular Units			
Type of Fixation	Complete Calculation Formula	Simplified Approximation	Errors of Approximation
Symmetric (Fig. 1)	(1) $\tan a_{deg}/2 = i/2D$	(3) $a_{rad} = i/D$	<1% for $a < 10$ deg (i.e., $D < 75$ cm)
Asymmetric (Fig. 2)	(2) $a_{rad} = (2j/D) - 2j(3x^2 + j^2)/3D^3 + 2j(5x^4 + 10x^2j^2 + j^4)/5D^5 - \dots$	(4) $a_{rad} = 2j/D$	% error = $(3x^2 + j^2)/3D^2 \times 100$
In Diopters (Fig. 3): (5) $\Delta = 1/D \cdot i$, where i is in centimeters and D is in meters			
Key	a_{deg} = convergence angle in degrees a_{rad} = convergence angle in radians Δ = convergence in diopters	i = IPD j = $i/2$ D = fixation distance	x = magnitude of lateral displacement of fixation from straight ahead Note 1 rad = 57.3 deg

Applications

The near point of convergence is ~ 0.05 m ($a = \sim 64$ deg) for normal observers; objects closer than this distance appear blurred or double. For distances greater than a few meters, the eyes are effectively parallel ($a \approx 0$ deg). Under normal viewing conditions, the eyes do not diverge beyond parallel.

Depth discrimination of targets varies with convergence angle. Convergence angle provides some information about absolute distance but is a relatively weak depth cue. For a given angular size of target at fixed distance, apparent size decreases as convergence angle increases.

Constraints

- Under normal conditions, changes in convergence angle are linked to accommodative changes of the lens of the eye. Decoupling of accommodation and convergence may result in discomfort during prolonged viewing and, for extreme cases, in loss of single vision (double images, or diplopia). Consequently, designs which manipulate convergence angle may need to incorporate adjustments for focus of each eye (CRefs. 1.222; 1.231).
- Resting convergence (convergence angle assumed by eyes in absence of any stimulus for fixation) is ~ 3 deg for normal observers. Some observers show marked deviation

from normal values; this should be considered in certain applications (CRef. 1.809).

- Definition of nonsymmetric convergence angle given here assumes that center of rotation of the eyeball is coincident with **optic node** of the eye. Since this is not strictly true, certain small errors of estimation are introduced, although these are generally too small to be of practical consequence. Detailed analysis and a more precise formula can be found in Ref. 2.
- Change in convergence angle is accomplished through eye movements. Convergence angle may be manipulated artificially by placing prismatic lenses in front of one or both eyes.

Key References

- Graham, C. H. (1965). *Vision and visual perception*. New York: Wiley.
- Gulick, W. L., & Lawson, R. B. (1976). *Human stereopsis: A psychophysical approach*. New York: Oxford University Press.
- Hochberg, J. (1971). *Perception*. II. Space and movement. In J. W. Kling & L. A. Riggs, (Eds.), *Woodworth and Schlosberg's experimental psychology* (pp. 475-482). New York: Holt, Rinehart & Winston.
- Scheie, H. G., & Albert, D. M. (1977). *Textbook of ophthalmology* (pp. 115-120). Philadelphia: W. B. Sanders.

Cross References

- 1.950 Factors affecting vergence eye movements;
1.222 Visual accommodation;
1.231 Relation between accommodation and convergence;
1.809 Phoria;
- 1.952 Vergence eye movements: eliciting target characteristics

1.809 Phoria

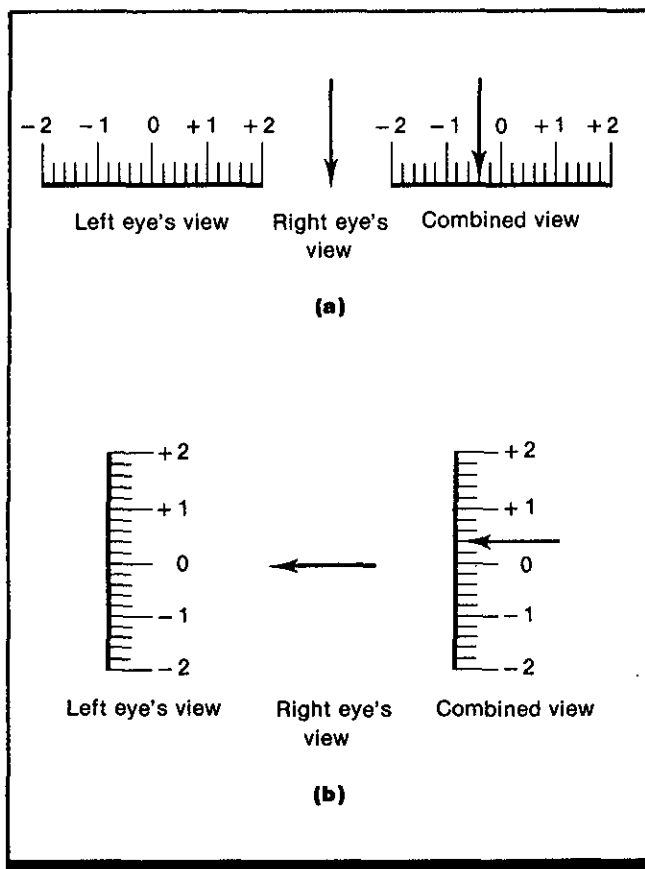

Figure 1. Stereograms used in measurement of (a) lateral and (b) vertical heterophoria. The combined views are for observers with (a) 0.4 diopter esophoria and (b) 0.4 diopter right hyperphoria.

Key Terms

Convergence; heterophoria; motor fusion; phoria; vergence eye movements

General Description

The proper alignment of the eyes in **convergence** to a fixation object is guaranteed by *motor fusion*, a mechanism which aligns spatial contours arising from the attended plane of fixation on corresponding points of the two **retinas** by convergent and divergent eye movements. *Phoria* is the vergence condition of the eyes when the stimulus to fusion is removed, e.g., when contours in the eyes are dissimilar and cannot be aligned. Such viewing conditions generally reveal some amount of *heterophoria*, the latent tendency

for one or both eyes to turn in (*esophoria*) or turn out (*exophoria*).

Orthophoria is the absence of heterophoria and is rarely observed. Heterophoria may also be vertical. Right *hyperphoria* occurs if the right eye exhibits a latent tendency to deviate upward; if it tends to deviate downward it is right *hypophoria*. Phoria must be distinguished from *tropia*, the vergence condition of the eyes when fusion contours are present.

Applications

Displays and viewing arrangements in which binocular alignment is critical even in the presence of grossly disparate half-fields; large uncorrected phorias, especially vertical phorias, can lead to visual problems and visual discomfort.

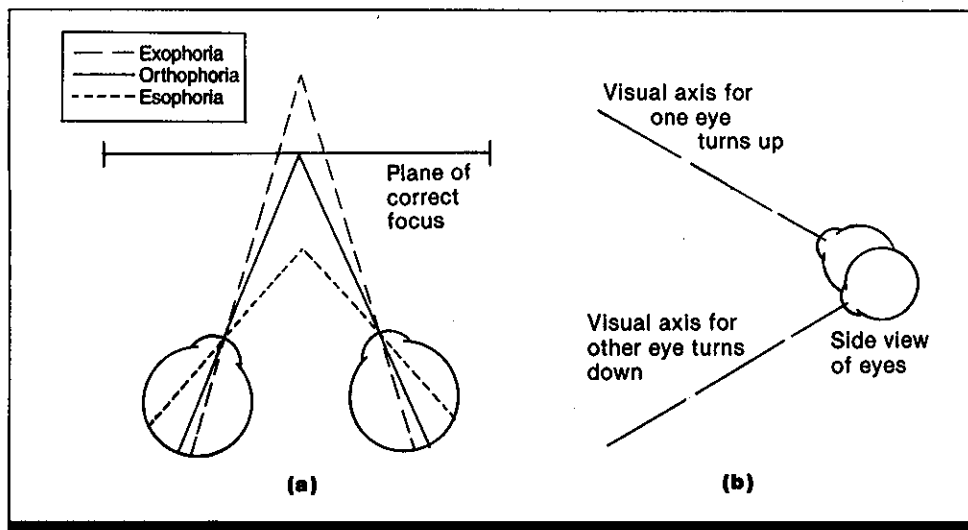

Figure 2. (a) Lateral phoria types: horizontal position of one or both eyes deviates when viewing dissimilar patterns as in Fig. 1a. (b) Vertical phoria: vertical position of one or both eyes deviates when viewing dissimilar patterns as in Fig. 1b. (From Ref. 2)

Methods

Testing Procedures

- To test for heterophoria, a stereoscope or other suitable instrument with prisms is used to force vergence to standard near-viewing (40-cm) or far-viewing (3-m) distances. The observer views stereo-

grams such as those in Fig. 1; one half-field has a pointer, the other an index calibrated in prism diopter units.

- The observer attempts to fuse the half-fields binocularly and reads the position of the pointer on the index.

Constraints

- Heterophoria by itself is not a visual problem, and its clinical value is primarily in relation to other measures, such as amplitudes of motor fusion.
- Fixation disparity** is found in most heterophorics, in the same direction as the phoria (Ref. 1).

Key References

- Bishop, P. (1981). Binocular vision. In R. A. Moses (Ed.), *Adler's physiology of the eye. Clinical application* (pp. 575-649). St. Louis: C. V. Mosby.
- Farrell, R. J., & Booth, J. M. (1984). *Design handbook for im-*

agery interpretation equipment. Seattle, WA: Boeing Aerospace.

- Ogle, K.N. (1950). *Researches in binocular vision*. Philadelphia: Saunders.
- Von Noorden, G.K. (1980). *Binocular vision and ocular motility*. St. Louis: C. V. Mosby.

Cross References

- 1.808 Convergence angle;
 1.810 Incidence of lateral and vertical phorias;
 1.912 Fixation stability: magnitude of horizontal drift

1.810 Incidence of Lateral and Vertical Phorias

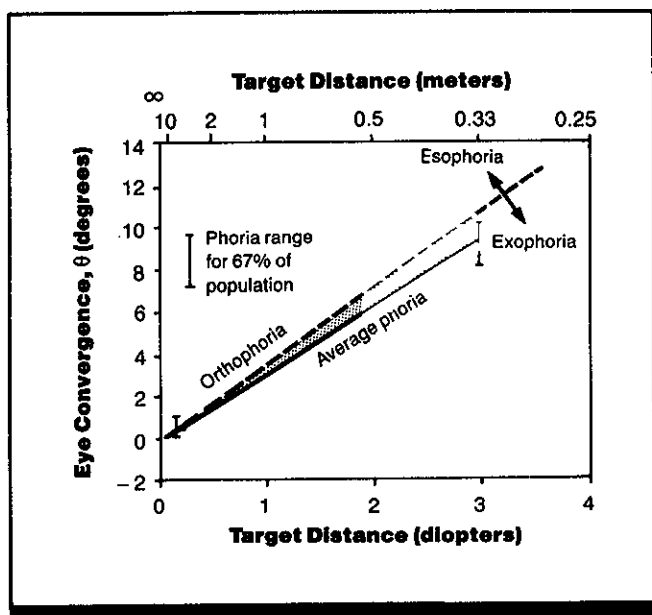

Figure 1. Lateral phoria in the normal population as a function of fixation distance (Study 1). (From Ref. 2)

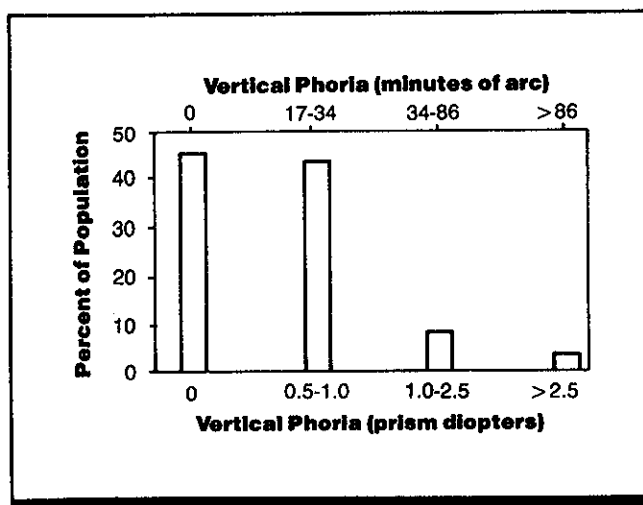

Figure 2. Incidence of vertical phoria in 1000 refraction cases (Study 2). (From Ref. 2)

Key Terms

Convergence; heterophoria; motor fusion; phoria; vergence eye movements

General Description

Under normal viewing conditions, when the eyes are converged on a fixation target, motor fusion causes spatial contours arising from the plane of fixation to align on corresponding points of the two retinas. When the stimulus to fusion is removed (i.e., the contours in the two eyes are dissimilar and cannot be aligned), the eyes frequently show a tendency to deviate from parallel, a condition known as *heterophoria*. Heterophoria can be lateral (one or both eyes turn inward [esophoria] or outward [exophoria]) or vertical

(one or both eyes deviate upward [hyperphoria] or downward [hypophoria]). In the general population, the average individual is slightly exophoric (eyes tend to turn out) at near distances and approaches orthophoria (no tendency to deviate) as distance increases (Fig. 1). Over half of a large sample of refraction patients (i.e., patients consulting an eye specialist in connection with refractive problems such as near-sightedness or far-sightedness) showed some degree of hyperphoria (upward deviation) (Fig. 2).

Applications

Displays and viewing arrangements in which binocular alignment is critical or situations which involve prolonged convergence to near distances. Uncorrected vertical phorias may lead to visual problems and visual discomfort.

Methods

Study 1 (Ref. 1)

- Data from 7,516 observers in 15 separate studies using a variety of methods

Study 2 (Ref. 3)

- Maddox rod test used to assess vertical phoria; 1000 refraction patients studied

Experimental Results

- Average lateral phoria increases as viewing distance increases. At 1/3 m, the average person has ~1.2 deg (2 prism diopters) of exophoria (convergence insufficiency). At 10 m, the average person is orthophoric.
- 55% of refraction patients have demonstrable hyperphoria; 43.2% have vertical phorias of <1 prism diopter

(0.57 deg), and less than 12% have >1 prism diopter of vertical phoria.

- Twice as many cases show greater hyperphoria at near distances than at far distances.

Variability

Bars in Fig. 1 indicate standard deviations about two data points.

Constraints

- The Maddox rod test is widely used but is a gross measure of phoria.
 - Figure 2 shows the incidence of vertical phoria in 1000 refraction cases but does not necessarily describe the normal population.
-

Key References

*1. Bureau of Visual Science. (1950). *American optical refraction handbook* (p. 105). American Optical Co.

2. Farrell, R. J., & Booth, J. M. (1984). *Design handbook for imagery interpretation equipment*. Seattle: Boeing Aerospace Co.

*3. Oaks, L. W., & Oaks, L. E. (1936). Some clinical observations on vertical phorias in one thousand refraction patients. *Eye, Ear, Nose and Throat Monthly*, 15, 333-336.

Cross References

1.809 Phoria;

1.813 Alignment and adjustment tolerances for binocular instruments;

1.912 Fixation stability: magnitude of horizontal drift

1.811 Eye Signature: Discrimination of Which Eye Is Stimulated

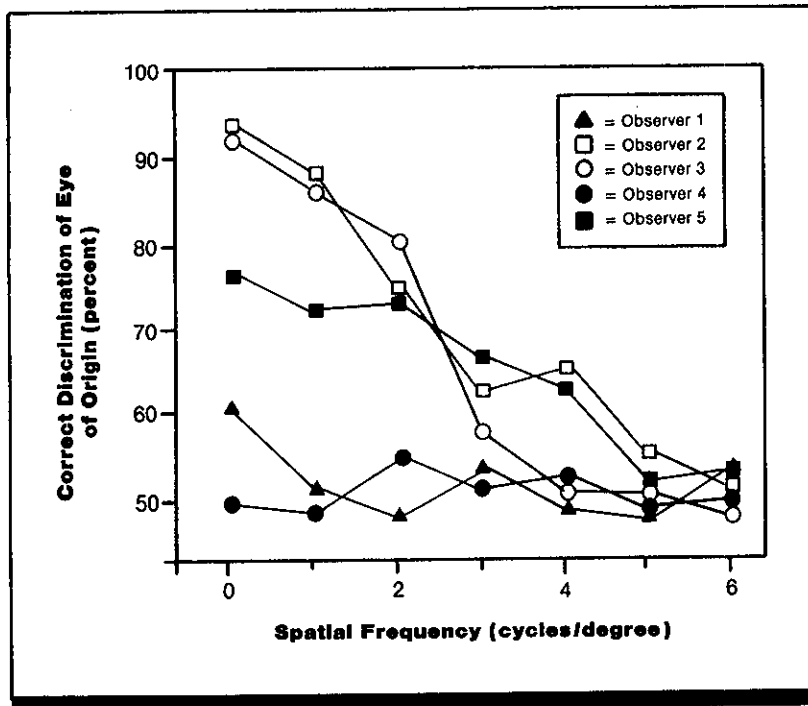

Figure 1. Discrimination of which eye receives a bar pattern when the other eye receives a blank field, as a function of spatial frequency of the bar pattern (1 cycle = 2 x width of individual bar). (From Ref. 1)

Key Terms

Eye signature; utrocular discrimination

General Description

Utrocular discrimination is the ability to distinguish which eye receives a target image when one eye views the target and the other eye sees a blank field. Most observers show reliable utrocular discrimination for relatively coarse bar patterns (sine-wave gratings of low spatial frequency).

Performance falls to chance levels, however, for targets with relatively narrow bars (high spatial frequency). For coarse bar patterns, observers are also able to discriminate which eye receives a pattern of higher contrast and whether the target is presented to one or to both eyes.

Applications

Stereoscopic and autostereoscopic display designs.

Methods

Test Conditions

- Two CRT monitors arranged as a mirror stereoscope with one eye viewing each screen; screen size 7×5 deg of visual angle; one screen blank, one filled by vertical bar pattern (sine-wave grating); bar width (spatial frequency)

- varied from 1-6 cycles/deg in 1 deg steps
- Mean luminance constant at 7 cd/m^2 ; patterns amplitude-modulated by Gaussian function with 1.5-deg space constant to remove abrupt lateral borders; 0.10 maximum contrast at center of patterned screen
- Viewing distance 114 cm

- Blocked counterbalanced conditions, with eye which received pattern randomly varied

Experimental Procedure

- Two-alternative forced-choice discrimination
- Independent variables: spatial frequency of grating, which eye viewed bar pattern

- Dependent variable: percent correct identification of which eye viewed pattern
- Observer's task: report which eye saw the bar pattern
- At least 100 trials per data point
- 5 observers with normal stereopsis as assessed by modified Orthorater

Experimental Results

- Four out of five observers perform better than chance in discriminating which of the two eyes views a bar pattern when the bars are relatively coarse (spatial frequency of 1 cycle/deg); however, performance declines to chance levels as bar width decreases (higher spatial frequencies).
- Follow-up experiments show good utrocular discrimination with more complex patterns if patterns contain significant energy at low spatial frequencies.
- In a related study, with a stationary vertical bar pattern presented to either one or both eyes, observers can discriminate monocular from binocular stimulation with an accuracy of >85% when the bars are 1 cycle/deg; performance falls to chance levels for 8 cycle/deg bars.
- In a second related study, when one eye is shown a coarse (1 cycle/deg) bar pattern of higher contrast than an identical bar pattern presented to the other eye, observers can dis-

criminate which eye receives the target of higher contrast provided that the difference in target contrast is >6-8 decibels. For contrast differences above this level, performance improves as contrast difference increases.

Variability

Ninety-five percent confidence intervals, assuming 100 trials per point, are ± 0.098 for 50% correct identification, ± 0.084 for 90%, and ± 0.058 for 75% correct identification. There is large variability from individual to individual as not all observers are capable of utrocular discrimination.

Repeatability/Comparison with Other Studies

Earlier studies have disagreed as to whether utrocular discrimination ever rises above chance performance, but none used bar patterns (see Ref. 3).

Constraints

- Utrocular discrimination seems to be unaffected by target distance from fixation, orientation of bar pattern, contrast of bars, target duration, or practice with feedback.

- Individuals who lack stereopsis perform this task well at all resolvable bar widths (Ref. 2).
- Utrocular discrimination seems to be unrelated to binocular summation or interocular transfer.

Key References

*1. Blake, R., & Cormack, R. (1979). On utrocular discrimination. *Perception & Psychophysics*, 26, 53-68.

2. Blake, R., & Cormack, R. (1979). Psychophysical evidence for a monocular visual cortex in stereoblind humans. *Science*, 203, 274-275.

3. Templeton, W. B., & Green, F. A. (1968). Chance results in utrocular discrimination. *Quarterly Journal of Experimental Psychology*, 20, 200-203.

1.812 Binocular Displays

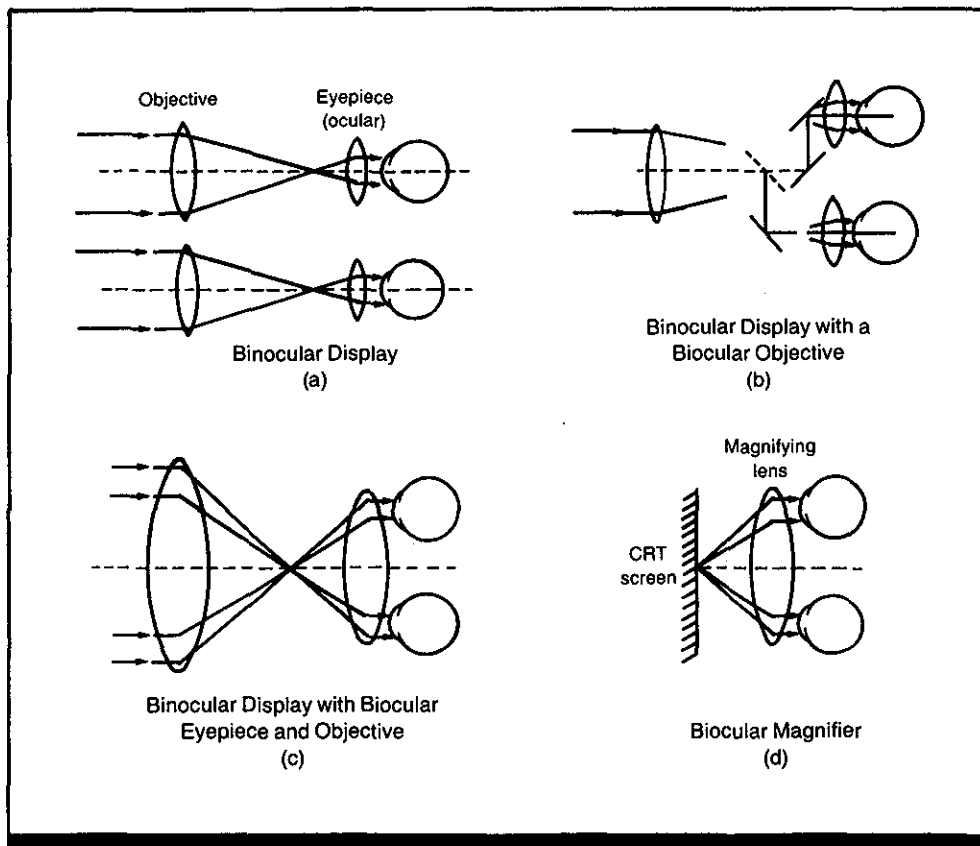

Figure 1. Some examples of lens arrangements in binocular displays. (From Ref. 1)

Key Terms

Autostereoscope; binocular display; pseudoscopic display; stereoscope; telestereoscope; volumetric display

General Description

Binocular displays are those for which an observer uses both eyes. If the same two-dimensional image is viewed by both eyes, the display is said to be *binoptic* (also called *monoscopic*). If different images are presented to the two eyes, the display is termed *dichoptic*; if these differences are depth-producing, the display is *stereoscopic* as well. Viewing the world with the unaided eyes is the simplest type of binocular display, and it is, of course, stereoscopic. When two eyes share a single optical element with a single axis of symmetry, that element is said to be *biocular*. An example of a biocular element is a single eyepiece of larger diameter than the *interpupillary distance*, through which both eyes gain access to the rest of the lens system. Several examples of the use of binocular elements are shown in Fig. 1b-d.

The use of lenses, prisms, mirrors, and other optical hardware often makes binocular displays complicated, but allows great flexibility in manipulating what the observer perceives, especially with regard to depth relations in the

visual environment. For example, mirrors can be made to amplify lateral **retinal image disparity** by effectively increasing the horizontal separation of the eyes. Such *telestereoscopic* displays have the effect of increasing apparent depth magnitude and improving linear (but not angular) depth discrimination. Similarly, if the two eyes' images (half-fields) are reversed, the normal stereoscopic depth relations are reversed, that is, objects that are farther than the fixation point in normal view appear nearer than the fixation point in this *pseudoscopic* view.

Autostereoscopic displays are those in which the visible pattern varies continuously with the viewing angle, and thus the observer may move about and see the displayed objects from different angles without destroying or diminishing the stereoscopic percept. Holographic displays are autostereoscopic, and although they appear truly three-dimensional, they are, in fact, reflected from a single flat plate. *Volumetric* displays, in contrast, use images that are actually dispersed through three-dimensional display spaces.

Constraints

- Binocular terminology is often confusing and inconsistent in the literature.
- Binocular displays are capable of disturbing the normal relations between retinal disparity, accommodation, and

convergence, and may produce discomfort unless these variables are calibrated properly (CRef. 5.912).

- Apparent depth in binocular displays depends on many cues other than stereopsis.

Key References

*1 Farrell, R. J., & Booth, J. M. (1984). *Design handbook for imagery interpretation equipment*. Seattle: Boeing Aerospace Co.

2. Okoshi, T. (1976). *Three-dimensional imaging techniques*. New York: Academic Press.

3. Valyus, N. A. (1966). *Stereoscopy*. London: Focal Press.

Cross References

1.813 Alignment and adjustment tolerances for binocular instruments;

5.912 Tolerance for vertical disparity;

5.914 Filter separation and free stereoscopic display methods

1.813 Alignment and Adjustment Tolerances for Binocular Instruments

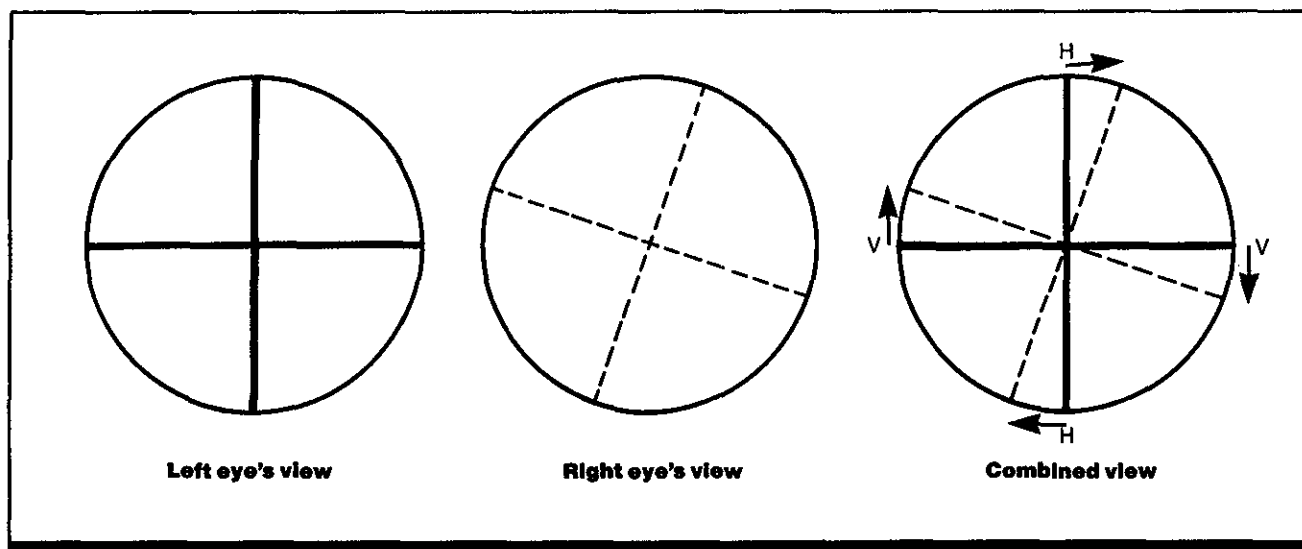

Figure 1. Vertical and horizontal displacement produced by relative rotation (rotation difference). Target is cross-hair reticle. Maximum vertical displacement (V) is at left and right field edges. Maximum horizontal displacement (H) is at top and bottom field edges. There is no displacement at center. Displacement increases with distance from center.

Key Terms

Binocular display; binocular misalignment; double vision; image alignment

General Description

A *binocular* instrument presents one image to the right eye and another to the left eye, each generally representing the same object or scene. With a well constructed and aligned instrument, adjusted to the user's **interpupillary distance** and focused for the user's eyes, only one object or scene is perceived and viewing is comfortable. However, all binocular instruments have slight differences between the two images in size (magnification difference), orientation (rotation difference), or location (vertical or horizontal misalignment). Small differences are unnoticeable; as differences of any of these three types increase, no discomfort is noticed initially, but extended use can cause severe headache. Very large differences between left and right images can cause eyestrain, possibly nausea, and headache. The scene or object will occasionally split into two objects or misregistered images and one image may be suppressed (not seen). When image differences are too large, single vision is impossible; double vision (diplopia) always occurs.

With optical axes misaligned, or with differences in magnification or rotation, all corresponding points in the two images are misaligned both vertically and horizontally. With axis misalignment, the amount of misalignment is uniform over the field. With either rotation or magnification differences, angular misalignment increases with angular distance from the field center.

With a *rotation* difference, R , maximum vertical misalignment, V , in the field of view (FOV) is on a horizon-

tal line through field centers at the field's edge. Maximum horizontal misalignment, H , also at field's edge, is on a vertical line through field center. Maximum V in minutes of arc for a rotation R in minutes with a total FOV of F deg is $V = R \sin (F/2)$. Maximum H is determined similarly.

With a *magnification* difference of d percent, the largest V in the FOV is at the edge of the FOV on a vertical line through field center. For a total FOV of F degrees, V in minutes is $V = 0.3 Fd$.

Tolerances for Image Differences

People differ greatly in tolerance to differences in the two images of a binocular instrument. Also, the criterion for tolerance is a significant factor. Tolerance limits based on comfort in use are much smaller (tighter, stricter) than tolerance limits for avoidance of double vision. In turn, these differ from tolerance limits based on the minimization of effect on **stereoacuity**. Tolerances and formulas for calculating misalignment have been extensively reviewed (Refs. 1, 5). The most valid research on comfort-in-use tolerances for head-up displays (Refs. 3, 4) recommends not over 3.4 min arc of vertical image misalignment, not over 8.6 min arc of convergent horizontal misalignment, and not over 3.4 min arc of divergent horizontal misalignment. Similar values for convergent (≤ 8 min arc) and divergent (≤ 4.1 min arc) misalignment were obtained in another study (Ref. 2). More horizontal misalignment than vertical misalignment is tolerable.

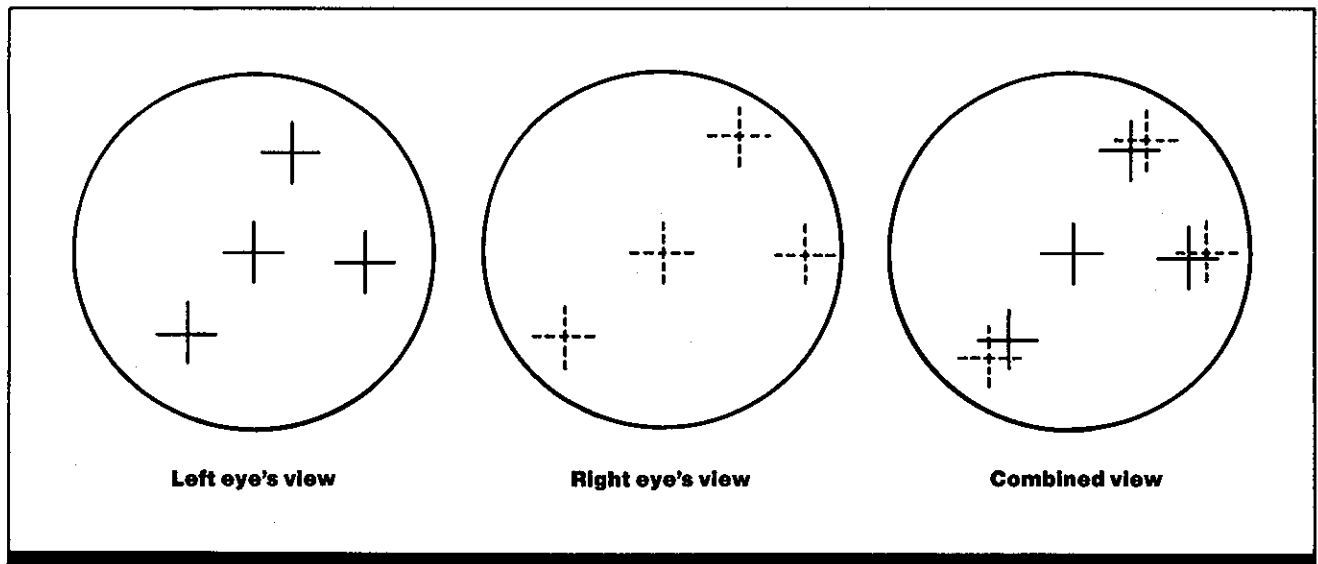

Figure 2. Vertical and horizontal misalignment produced by magnification difference. Targets are cross-hair reticles. Magnification differences cause no misalignment at center but do cause vertical misalignments along the vertical axis through center and horizontal misalignments along the horizontal axis through center. Displacement is maximum at the edges of the field; vertical displacement is maximum at top and bottom, horizontal displacement is maximum at sides.

Applications

Tolerance specifications are required when designing, constructing, purchasing, or testing binocular instruments. Repair and maintenance adjustment also require tolerance values.

Constraints

• For instruments that are focused so that the two images, right and left, are closer than optical infinity, convergence required of the observer's eyes should agree with the optical distance of the images.

• The eyes of individuals with *phorias* (CRef. 1.809) have a tendency to depart from parallelism of the visual axes for distant objects. Device misalignment, when in a direction opposite to the phoria, can cause problems for these individuals, even though the misalignment is within tolerance limits for most people.

Key References

1. Farrell, R. J., & Booth, J. M. (1984). *Design handbook for imagery interpretation equipment*. (Boeing document No. D180-19063-1). Seattle, WA: Boeing Aerospace Co.

2. Genco, Louis V. (1983). Optical interactions of aircraft windscreens and HUDs (head-up displays) pro-

ducing diplopia. Reported in Wayne L. Martin (Ed.), *Optical and human performance evaluation of HUD system design*, (AFAMRL-TR-83-5019) Wright-Patterson Air Force Base, OH: Air Force Aerospace Medical Research Laboratory. (DTIC No. ADA140601)

3. Gold, T. (1971). Visual disparity tolerances for head-up displays.

Electro-optical system design conference, Anaheim, CA (pp. 399-406). Chicago, IL: Industrial and Scientific Conference Management, Inc.

4. Gold, T., & Hyman, A. (1970). *Visual requirements for head-up displays*. (JANAIR Tech. Rep. No.- 680712). Great Neck, NY:

Sperry Rand Corp. (DTIC No. ADA174536)

5. Self, H. C. (1986). Optical tolerances for alignment and image differences for binocular helmet-mounted displays (AAMRL-TR-86-019). Wright-Patterson AFB, OH: Air Force Aerospace Medical Research Laboratory. (DTIC No. ADA1745362)

Cross References

1.809 Phoria;

5.907 Retinal image disparity due to image magnification in one eye;

5.908 Retinal image disparity due to image rotation in one eye

1.814 Probability Summation

Key Terms

Binocular summation; probability summation; statistical independence; target detection

General Description

Probability summation refers to the inherent advantage that a detection process has under conditions of multiple, statistically independent detection opportunities, relative to a single detection opportunity. For example, if an observer is given two independent trials (opportunities) to detect a dim light, the probability of detection will be greater than it would be given a single trial, because detection can take place on either trial. More subtle cases of probability summation in sensory systems are those in which it is reasonable to suppose that different subsystems have independent opportunities to simultaneously detect a stimulus. There has been a large body of literature devoted, for example, to testing the assumption that each of the two eyes has an independent opportunity to detect a **binocular** stimulus, and this example will serve to introduce basic probability summation concepts. In its earliest and simplest formulation (Ref. 5), binocular performance is assumed to be determined by the logical **OR** of each eye's decision (either the left [*l*] eye, or the right [*r*] eye, or both eyes, detect). Equivalently,

$$P_b = 1 - (1 - P_l)(1 - P_r) \quad (1)$$

that is, binocular probability (probability of detection using both eyes) (P_b), is 1 (the certain event) minus the probability that neither the left nor the right eye detected the stimulus. Note that the probability summation advantage is measurable only in situations such as near-threshold stimulation levels where behavior on a particular trial is uncertain.

There have been nearly as many different models of probability summation as there have been sensory threshold models, for all testable probability summation models require the adoption of an underlying threshold model. A refinement of the logic described by Eq. 1, for example, was proposed by Eriksen (cited in Ref. 1) to account appropriately for guessing behavior assuming a two-state, high-threshold model. The model assumes that the observer's detection behavior allows him or her to be in only one of two states: a correct detection state or a guessing state. When this refinement is applied to binocular probability summation (Ref. 1), the binocular probability of responding correctly is given by

$$P_b = 1 - G_l G_r + G_l G_r / n \quad (2)$$

where n is the number of response alternatives, and G_l and G_r are the proportions of guess trials estimated from **monocular** performance P_l and P_r (estimates are given by $[1 - P_l]/[1 - 1/n]$ and $[1 - P_r]/[1 - 1/n]$ respectively).

Equation 2, the appropriate probability summation estimator for the high-threshold, two-state model, predicts a greater performance increment due to probability summation than any model based on multiple states. Therefore, when testing for increased performance due to connectivity between systems (such as the two eyes), it provides the most conservative baseline against which to compare empirically observed increments.

Most probability summation models predict performance increments expressed as performance probabilities, rather than as threshold enhancements. The Campbell and Green (Ref. 2) model, however, based on the theory of signal detection, predicts a $\sqrt{2}$ binocular improvement in **contrast sensitivity** relative to (equal) monocular sensitivities. Their model assumes that monocular responses have uncorrelated noise that is sampled, and that the sum of such samples is what comprises, or limits, the binocular response.

Watson et al. (Ref. 7) have developed a model of probability summation that assumes a mathematically similar but more convenient **psychometric function** than the usual normal integral. From that model, they also derive threshold predictions. Applied to the binocular enhancement of contrast, a model of that form would assume that monocular performance probabilities are expressed as

$$P_l = 1 - \exp[-(I_l/\alpha_l)^\beta]$$

and,

$$P_r = 1 - \exp[-(I_r/\alpha_r)^\beta]$$

where I_l and I_r are monocular contrasts, α_l and α_r are contrast thresholds, and β is a parameter equal to the slope of the psychometric functions at $P = 0.50$. For the case where the monocular thresholds are equal, Ref. 7 proves the following relation, expressed in decibels:

$$dB(\alpha_l) - dB(\alpha_b) = 6/\beta$$

where α_b is the binocular contrast threshold. Notice that when $\beta = 1$, binocular sensitivity should be 6 dB, or about twice monocular sensitivity.

Applications of probability summation concepts

In sensory science, probability summation estimates have been used in two ways: (a) as baselines against which to measure neural connectivity, as in binocular summation, or (b) as a means of demonstrating independence, or lack of connectivity between structures. In demonstrating neural interaction between the eyes in binocular summation experiments, as an example of (a), one must show that perfor-

mance probabilities or threshold sensitivities exceed those predicted by mere probabilistic considerations (i.e., probability summation). This issue of neural summation in binocular summation has received a great deal of attention in recent years (Ref. 1), and has often been ascribed a more substantive role in mediating interaction between sensory mechanisms than probability summation. However, probability summation, too, involves neural integration: but of *decisions* output by each mechanism, rather than of signals on which decisions are made.

Demonstrating binocular neural summation, that is, convergence of monocular signals prior to detection decisions, involves showing that binocular sensitivity not only exceeds monocular sensitivity, but exceeds that predicted by probability summation. Since, however, the appropriate threshold and probability summation rules may be points of contention, some investigators have circumvented these issues by empirically estimating probability summation effects. Two methods used are to measure simultaneous detection of targets presented to very disparate locations in a single eye (Ref. 6), and to measure detection of targets presented to the same eye under non-simultaneous conditions (Refs. 4, 6). Both methods are intended to test performance under conditions where the two "looks" at the stimulus can be assumed to be independent (because of spatial or temporal separation). Under both methods, binocular summation has been found to produce modest but clearly demonstrable binocular neural summation (i.e., performance increments larger than those due to probability summation as measured by these two methods; Ref. 1).

As a means of demonstrating independence of mechanisms, probability summation plays a weaker role because of methodological problems in affirming the null hypothesis (a hypothesis of no interaction), but it has an important explanatory role. For example, early multiple-channel models of spatial analysis assumed that one channel (the one most sensitive to the stimulus) always detects the stimulus. Probability summation between channels with independent variability (uncorrelated noise) was a refinement that helps to explain a number of threshold summation experiments with aperiodic (broadband) stimuli that would otherwise make multiple channel models less tenable (Ref. 3). Probability summation has also been used to explain the slightly higher detectability of so-called counterphase sine-wave gratings, which are composed of two gratings drifting in opposite directions at equal speeds, compared with stationary single gratings. Since the increment in detectability falls within the range predicted by probability summation, counterphase gratings are thought to be detected by independent channels, each maximally sensitive to one direction of image motion.

The above are examples of probability summation logic applied to a few specific problems. However, the ideas are applicable whenever it is reasonable to suppose, or to test the supposition, that two or more processes that make detection decisions do so independently prior to combining their decisions.

Key References

1. Blake, R., & Fox, R. (1973). The psychophysical inquiry into binocular summation. *Perception & Psychophysics*, *14*, 161-185.
2. Campbell, F. W., & Green, D. G. (1965). Monocular versus

binocular visual acuity. *Nature*, *208*, 191-192.

3. Graham, N. (1977). Visual detection of aperiodic spatial stimuli by probability summation among narrowband channels. *Vision Research*, *17*, 637-652.
4. Matin, L. (1962). Binocular

summation at the absolute threshold for peripheral vision. *Journal of the Optical Society of America*, *52*, 1276-1286.

5. Pirenne, M. H. (1943). Binocular and unocular thresholds in vision. *Nature*, *152*, 698-699.
6. Thorn, F., & Boynton, R. M. (1974). Human binocular summa-

tion at absolute threshold. *Vision Research*, *14*, 445-458.

7. Watson, A. B., Thompson, P. G., Murphy, G. J., & Nachmias, J. (1980). Summation and discrimination of gratings moving in opposite directions. *Vision Research*, *20*, 341-347.

Cross References

- 1.627 Target detection: effect of spatial uncertainty;
- 1.802 Monocular versus binocular contrast sensitivity;
- Handbook of perception and human performance*, Ch. 23, Sects. 1.1, 1.2

Notes



Section 1.9 Eye Movements

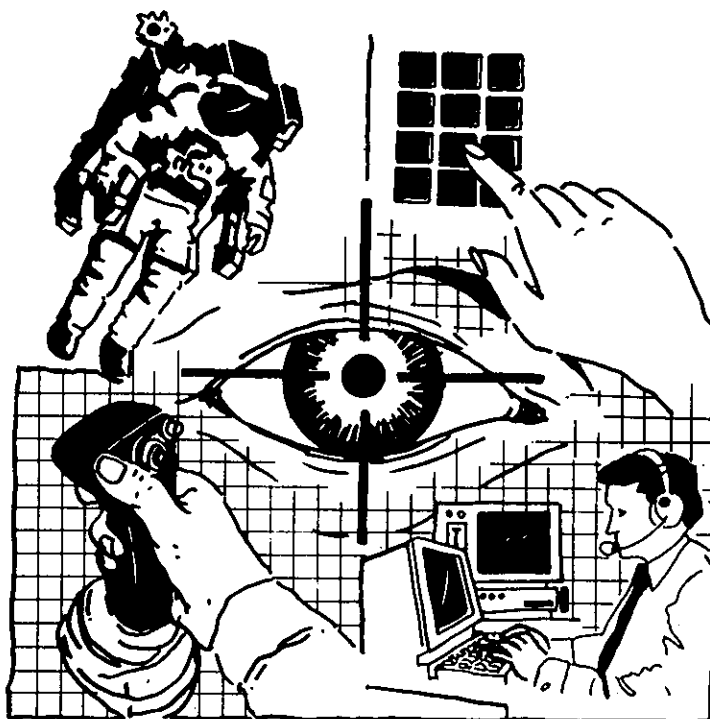

1.901 Anatomy and Mechanics of Eye Movements

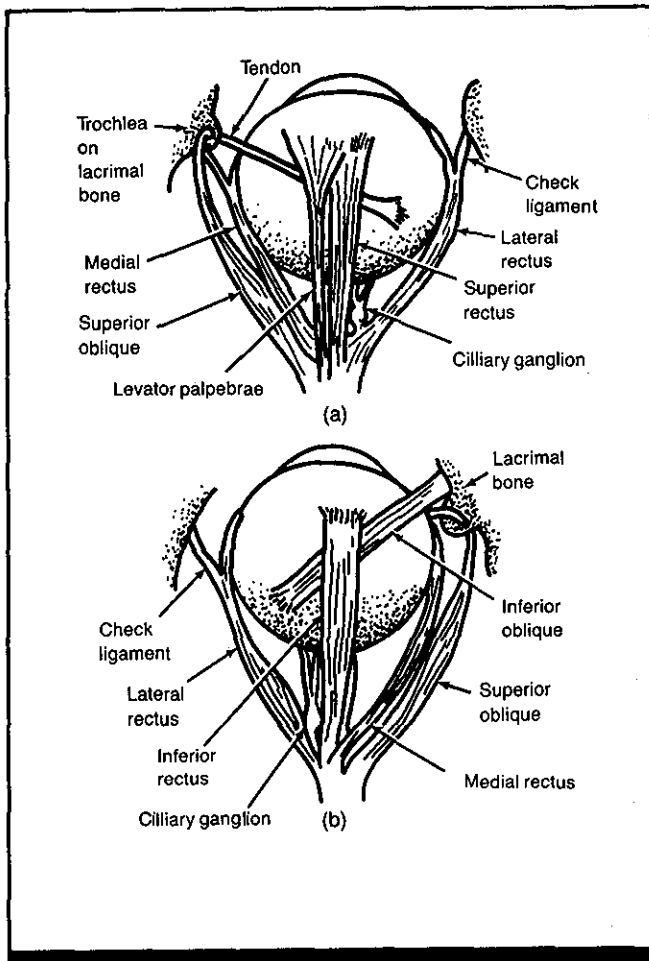

Figure 1. (a) Relative positions of the six extraocular muscles and their insertions (sites of attachments) as seen from above the eye; (b) relative positions of the extraocular muscles and their insertions as seen from below. (From Ref. 1)

Key Terms

Cycloduction; nystagmus; oblique muscles; physiological nystagmus; rectus muscles; torsion

General Description

There are three sets of extraocular muscles that control the movement and positioning of the eye. These muscle pairs include the horizontal and vertical rectus muscles, the lateral and medial rectus muscles, and the inferior and superior oblique muscles. Their positions are illustrated schematically in Fig. 1a, b. The positions and axes of orientation for some of the muscles are depicted in Figs. 2 and 3. The muscles do not all contribute equally to each possible movement of the eyes, but the relative contributions can be predicted (CRef. 1.902). Each pair of muscles exerts effort in a different axis, so that the eye is capable of movement to an extremely large number of positions. Some of the movements

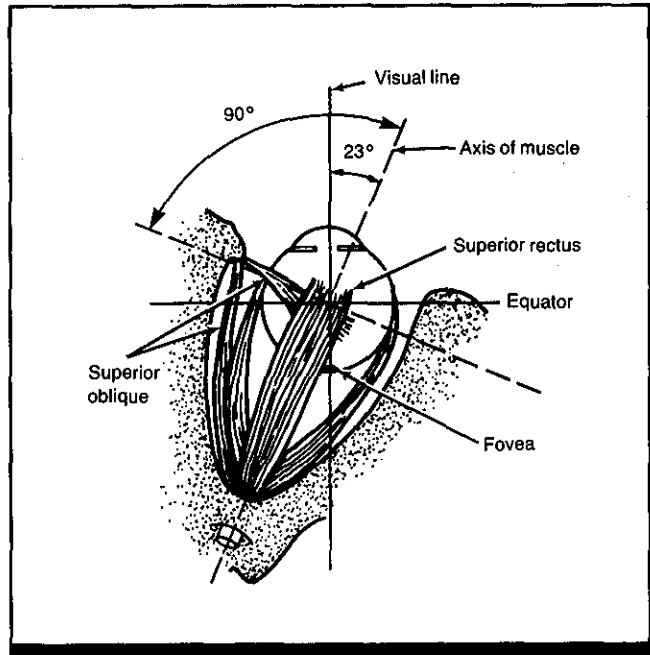

Figure 2. Extraocular muscles and eye in the standard anatomical position, as seen from above, showing insertion and axis of superior rectus in relation to the anatomical straight-ahead. (From Ref. 3)

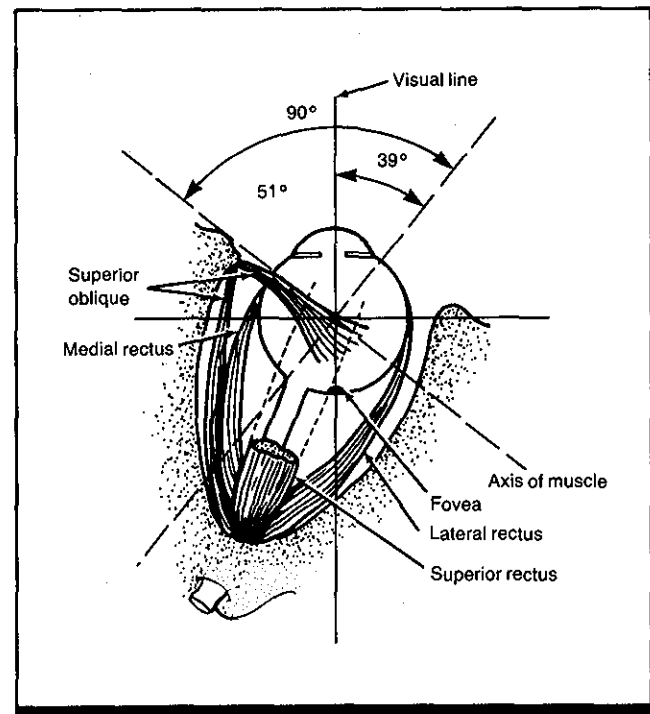

Figure 3. Extraocular muscles and eye in the standard anatomical position, as seen from above, showing insertion and axis of medial and lateral rectus muscles and of the superior oblique muscle in relation to the anatomical straight-ahead. (From Ref. 3)

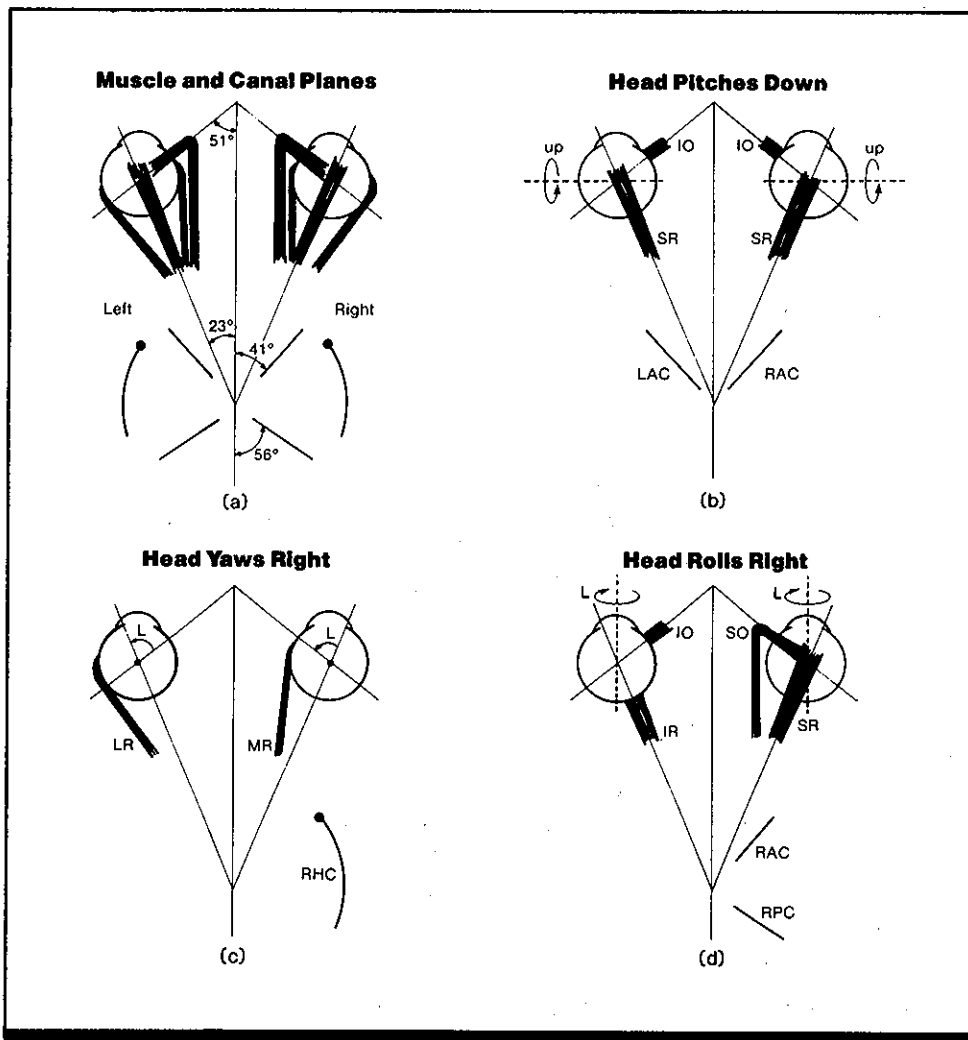

Figure 4. (a) Schematic diagram showing the semi-circular canals of the inner ear and the eye muscles that are activated by different movements of the head (i.e., yaw, pitch, and roll). The canals and the muscles interact through shared neural pathways so that head movements and compensatory eye movements are related. (b, c, d) The extraocular muscles and semi-circular canals that are implicated in particular head movements. The arrows near the axes show the compensatory eye movements. (LR, MR, SR, IR = lateral, medial, superior, inferior recti. IO, SO = inferior, superior obliques. RHC, LHC = right, left horizontal canal. RAC, LAC = right, left anterior canal. RPC, LPC = right, left posterior canal.) (From Ref. 2)

are involuntary and involve compensatory responses to movements of the head or to stimulation of certain facial nerves.

Vestibular reactions interact with the visual responses through shared neural pathways between the extraocular muscles and the six semicircular canals (CRef. 3.201); each semicircular canal excites one ipsilateral muscle and one contralateral muscle. The relations are given in Table 1. The positions of the canals and of the muscles appear in Fig. 4a. The head movements leading to the compensatory responses are illustrated in Fig. 4b, c, d. There is also a wide variety of voluntary muscle movements that are under control of the observer; these movements can be classified on a number of dimensions, including speed (CRef. 1.906), purpose (CRef. 1.906), and direction (CRef. 1.902).

Table 1. Summary of pattern of excitation of extraocular muscles by movements exciting the vestibular semicircular canals of the inner ear.

Canal	Muscles Affected
Anterior Canal	Ipsilateral superior rectus Contralateral inferior oblique
Posterior Canal	Ipsilateral superior oblique Contralateral inferior rectus
Horizontal Canal	Ipsilateral medial rectus Contralateral inferior rectus

Key References

1. Barlow, H. B., & Mollon, J. D. (Eds.). (1982). *The senses*. New York: Cambridge University Press.

2. Hallett, P. (1986). Eye movements. In K. R. Boff, L. Kaufman, & J. P. Thomas (Eds.), *Handbook of perception and human performance: Vol. 1. Sensory processes*

and perception. New York: Wiley.

3. Moses, R. A. (1981). *Adler's physiology of the eye* (7th ed.). St. Louis: C. V. Mosby.

Cross References

1.902 Muscular control of the eyes;
1.905 Summary of eye movements according to direction and axis of rotation;

1.906 Classifications of eye movements;
3.201 The vestibular system

1.902 Muscular Control of the Eyes

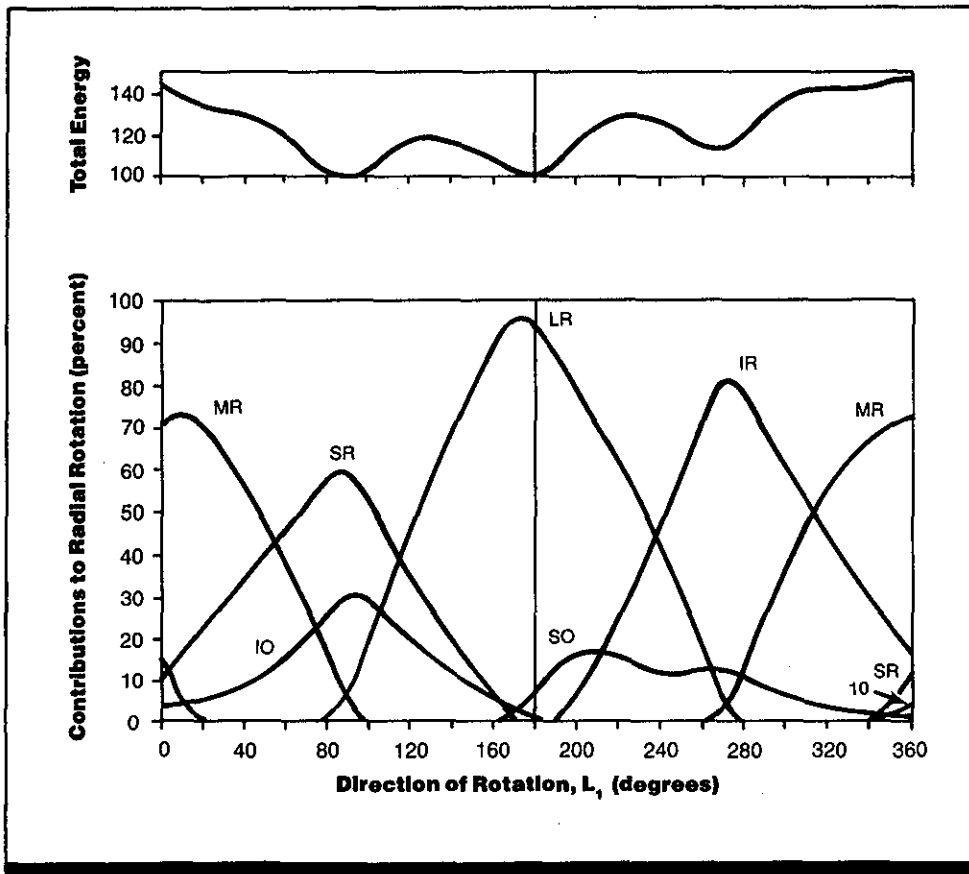

Figure 1. Index of contribution of individual muscles to eye movements (lower portion) and the relative amounts of energy expended in these movements (upper portion). L_1 is the direction of eye movement in the Listing coordinate system, where 0 deg is adduction, 90 deg elevation, 180 deg abduction, and 270 deg depression. The magnitude of rotation, L_2 , is 30 deg. In the lower panel, the effective contribution is the estimated exertion of a muscle (degree of contraction times muscle force), corrected for the movement of the eye in a direction at an angle to the muscle's axis. In the upper panel, the total muscular energy required for a given movement is plotted relative to the minimal amount of effort required for any eye positioning (with minimum = 100); the value of the curve on the y-axis at any point is the percentage of energy expenditure relative to the minimum. (MR, LR, SR, IR = medial, lateral, superior, inferior rectus muscles; IO, SO = inferior, superior oblique muscles.) (From P. Boeder, *The cooperation of extraocular muscles*. Published with permission from *The American Journal of Ophthalmology*, 51. Copyright 1961 by the Ophthalmic Publishing Company)

Key Terms

Adduction; convergence; esophoria; exophoria; horizontal rectus; inferior oblique; lateral and medial rectus muscles; phoria; superior oblique; vertical rectus

General Description

Movements of the eyes are effected by the three pairs of extraocular muscles (horizontal and vertical recti, lateral and medial recti, and inferior and superior obliques). Those muscles do not participate equally in movement, however. Estimates have been made (Ref. 1) of the relative effect that

the individual muscles have on the movements (Fig. 1). These estimates are based on presumed energy expenditure computed by multiplying the calculated contraction by the muscle's force (which is proportional to its cross-section). In actual viewing situations, such energy expenditures may induce heterophoric shifts, that is, differences between the actual alignment of the eyes due to functioning of the extra-

ocular muscles and the normal binocular eye positions for a given fixation. The possible inaccurate alignments include **exophoria**, the tendency to converge the eyes in a position beyond the target, and **esophoria**, the tendency to converge in front of the target. These phorias are the tendency to turn in or out even when not trying to fixate. The total energy expenditure varies, with minima for elevation (eye movement upward) and for abduction (movement sideways and out), with a second, slightly higher minimum for depression. Maximum energy expenditure is for adduction.

Prolonged viewing of a close object may induce inaccurate estimates of the distance to a visual target, even when the task is threading a needle under naturalistic conditions (Ref. 2). The errors in distance estimates are a result of an esophoric shift, a loss of fixation accuracy. However, these errors can be minimized when targets are viewed in full-field, normal lighting situations with the observer allowed free head movement.

Methods

Test Conditions

- For distance perception test observer binocularly-viewed small (3 mm²), circular, luminous target with either reduced-field viewing at 0.10 cd/m² (0.03) or field viewing at 20.58 cd/m² (6.00 fL); observer positioned pointer at same distance as target with unseen right hand; free head movement by observer; target at 30-36 cm from observer (average = 33 cm)

- Bausch and Lomb Ortho-Rater used for phoria pretests and post-tests; observer indicated perceived horizontal position of a vertical arrow
- Phoria induced for Exp. 1 by three 5-min periods of close handwork (i.e., needle threading with left hand) in room illuminated with sixteen 34-W fluorescent lamps; handwork alternated with distance perception test; monetary reward for each time needle was threaded

- Phoria induced for Exp. 2 by observer viewing small, circular, luminous disc subtending 2.6 deg of visual angle and flanked by two vertical bars; viewing period of 10 min, with illumination at 7.31 cd/m² (2.31 fL)
- Observer's head held in fixed position via chin and forehead rest; disc at 11 cm from observer in median plane at eye level

full-versus reduced-field viewing

- Dependent variables: distance from handwork to eyes (Exp. 1), degree of esophoric shift, estimates of distance to target
- Observer's task: for distance, position pointer at same distance as target using unseen hand; for phoria, report arrow position by reporting which dot appeared in line with vertical arrow
- 10 undergraduates (Exp. 1), 16 undergraduates (Exp. 2)

Experimental Procedure

- Independent variable: time spent on phoria-inducing task (Exp. 1),

Experimental Results

Experiment 1

- With free-movement of head, observers choose viewing distances (average = 21.3 cm) similar to distances previously found to produce esophoric shifts with fixed-head conditions.
- Close handwork produces significant esophoric shift (average = 1.20 diopters).
- In reduced-field viewing, observers significantly overestimate distance to target by an average of 1.22 cm.
- Full-field viewing eliminates the esophoric shift.

Experiment 2

- With fixed-head viewing, there is a significant average esophoric shift of 4.65 diopters and an average overestimation of 6.34 cm in reduced viewing conditions;

there is an average 2.3-cm overestimation with full-field viewing.

- Full-field viewing led to significantly greater overestimation of distances relative to reduced-field viewing.

Variability

The range of average distances at which observers held their handwork was 14.7-33.8 cm; there was considerable within-subject variability, with the smallest within-subject range at 15.2-15.8 cm and the largest at 12.7-30.5 cm. Three observers were dropped from Exp. 1 because of high variability in their pretest pointing responses. Two observers dropped from Exp. 2 because of poor performance in the distance perception pretest. *t*-tests were used to test significance.

Constraints

- Wide individual differences make specific predictions difficult.

Key References

1. Boeder, P. (1961). The co-operation of extraocular muscles. *American Journal of Ophthalmology*, 51, 469-481.

*2. Shebilske, W. L., Karmiol, C. M., & Proffitt, D. R. (1983). *Journal of Experimental Psychology: Human Perception and Performance*, 9, 270-277.

Cross References

1.901 Anatomy and mechanics of eye movements;
1.905 Summary of eye movements

according to direction and axis of rotation;
1.906 Classification of eye movements

1.903 Coordinate Systems for Describing Eye Movements

Key Terms

Binocular eye movements; Fick coordinate system; Helmholtz coordinate system; horizontal eye movements; Listing coordinate system; torsion; vertical eye movement

General Description

The three coordinate systems used to describe the movements of one eye specify three different and perpendicular polar axes: in one system the polar axis is horizontal and passes through the centers of both eyes, in the second it is vertical, and in the third it is horizontal and perpendicular to the other polar axes, coinciding with the line of sight in the standard anatomical position. Each alternative confers different advantages.

The table and figures summarize the three coordinate systems that specify eye movements: Helmholtz's system, Fick's system, and Listing's system.

The eye does not use all three of its degrees of rotational freedom. In the absence of head tilt, and with stationary visual surroundings, the degree of torsion measured relative to any system of axes is determined by the degree of horizontal and vertical rotation and is the same regardless of how the eye arrives at the position. Consequently, eye position needs only two, and not three, parameters to be fully described.

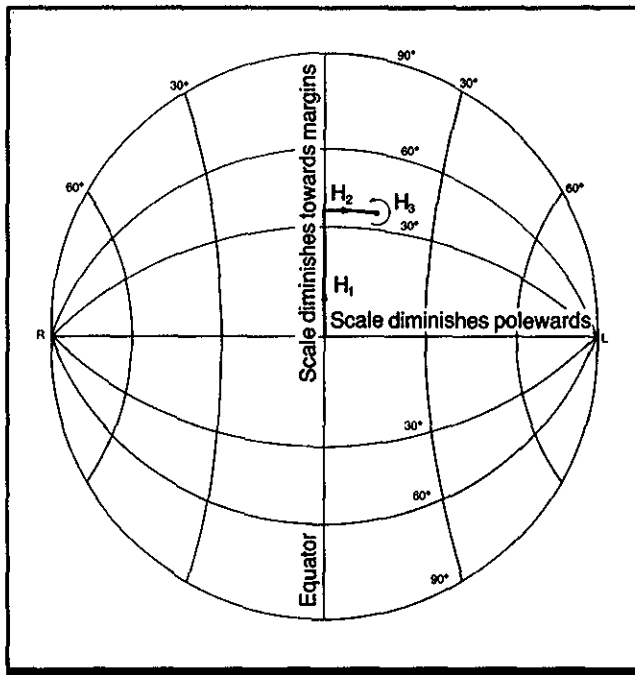

Figure 1. The Helmholtz coordinate system. The polar axis is horizontal and the eye is imagined as being at the center of the geodesic sphere. An arbitrary position of the line of sight can be specified by ascending the equator by H_1 deg, moving outwards H_2 deg along a meridian, and then rolling H_3 deg around the line of sight. Lambert's zenithal equal area projection. (From Ref. 3)

System	Description	Advantages and Disadvantages
Helmholtz system (Fig. 1)	The polar axis is horizontal and passes through both eyes. The useful plane of regard is defined as the plane that includes this axis and the lines of sight of both eyes. The plane of the zero meridian corresponds to the horizontal plane of regard, and the other meridian circles correspond to various elevations of the plane of regard	<p>The straight-ahead position is less precisely defined vertically than horizontally. If some correction has to be made on this account, only the elevation components of the position have to be modified (by simple addition)</p> <p>It is also easier to determine binocular movements with this system, because each eye fixating the same object, by definition, has the same elevation component. The angle of vergence is then given by the difference between the H_2 angles of each eye</p>
Fick system (Fig. 2)	The polar axis through the eye is vertical. The planes of the meridians of longitude are useful reference planes	<p>An error in the straight-ahead position will affect both the apparent latitude and longitude of eye position by an amount that is a complex function of both</p> <p>Also, if binocular movements are considered, each eye has different longitudinal and latitudinal components, and the vergence angle is a complex function of both</p>
Listing system (Fig. 3)	The polar axis is horizontal and coincides with the line of sight when the eye is in the primary anatomical position. The meridians specify the directions, and the circles of latitude the eccentricities, of stimuli that may attract the eye	<p>This system removes the asymmetry implicit in the two other systems</p> <p>L_3 is usually zero in the absence of head tilt. This system is inferior to Helmholtz's system, though, in dealing with binocular movement</p> <p>The system is mainly used when the interest is in the visual, and not the oculomotor, system</p>

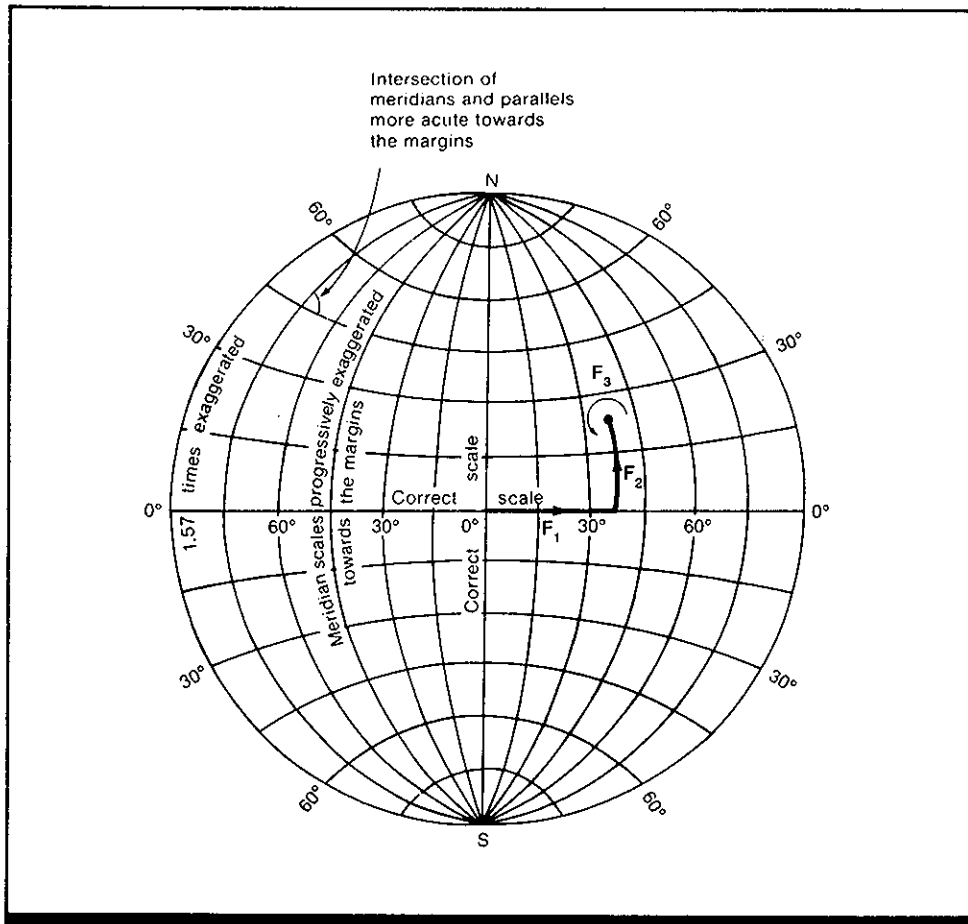

Figure 2. The Fick coordinate system. The polar axis is retinal. The point 0,0 is the straight-ahead or primary position of the line of sight. The static orientation of the eye at another position is specified by moving F_1 deg horizontally along the equator to the meridian, ascending to the latitude F_2 , and rolling around the line of sight by F_3 deg. Zenithal equidistant projection. (From Ref. 3)

Key References

1. Carpenter, R. H. S. (1977). *Movements of the eyes*. London: Pion.
2. Fry, G. A. (1968). Nomograms for torsion and direction of regard. *Archives of the American Academy of Optometry*, 45, 631-641.
3. Hallett, P. E. (1986). Eye movements. In K. R. Boff, L. Kaufman, & J. P. Thomas (Eds.), *Handbook of perception and human performance: Vol. 1: Sensory processes and perception*. New York: Wiley.
4. Helmholtz, H. (1926). *Physiological optics* (J. P. C. Southall, Ed. and Trans.) New York: Dover. (Original work published 1910)

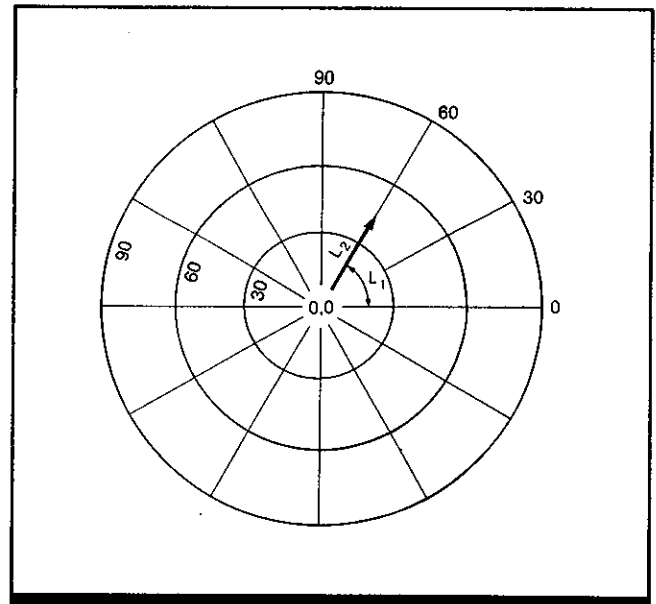

Figure 3. The Listing coordinate system. The polar axis is horizontal and corresponds with the line of sight in the primary anatomical position. A new orientation of the eye is specified by moving L_2 deg along a chosen meridian L_1 away from the pole (0,0) or primary axis. There is usually no rolling L_3 around the line of sight (Fick's Law). Zenithal equidistant projection. (From Ref. 3)

1.904 Methods of Measuring Eye Movements

Key Terms

Corneal reflection; electro-oculography; eye movement measurement; Purkinje image; retinal image

General Description

Instruments that measure eye movements detect the angular rotations of the eyes (i.e., changes in eye orientation) and ignore eye movements resulting from head or body movement. The methods defined in this entry are commonly used to measure eye movements.

Detailed information about apparatus, methodology, advantages and disadvantages of each method, observer-related factors, and tradeoffs are given in Ref. 5. The choice of an optimum method for any situation will depend on such factors as the type of data needed, the necessity of knowing the position of the observer's head, the type of observer (e.g., adults or children), and such tradeoffs as precision versus observer comfort. There are also tradeoffs between range and accuracy, between speed and signal noise, and between simplicity and complexity of output processing.

- **Contact lens method:** The contact lens is a spherical surface that is in tight contact with the cornea and the sclera; when the eye moves, the lens should move with very little slippage. An optical device, such as a mirror surface, or a non-optical device, such as two wire coils, is attached to or embedded in the lens and is used in sensing and recording eye movements. The contact lens method is one of the most precise forms of eye-movement measurement, but at a cost in setup time, observer comfort, and hazard.

- **Corneal reflection:** Light reflected from the cornea surface is imaged by a lens on some type of recording device or transducer (e.g., film or photocells).

- **Distance from corneal reflection to pupil center or retinal image tracking:** The reflection of a source of illumination (e.g., single or one of multiple lights, or scene illumination) is used to track corneal reflection (e.g., the image of a light

source or part of the visual scene) with respect to the center of the observer's pupil. A similar method tracks a retinal image (e.g., a spot of light) with respect to some other prominent landmark on the retina (e.g., a pronounced blood vessel).

- **Double Purkinje image measurement:** This method requires tracking two of the four Purkinje images (reflections) that occur at various depths in the eye: the first Purkinje image, which is the corneal reflection, and the fourth Purkinje image, which occurs at the interface of the lens with the vitreous humor. The relationship between the two images is invariant during eye translation, but changes whenever the eye is rotated.

- **Electro-oculography (EOG):** Skin electrodes located around the eye record the potential differences resulting from the corneoretinal potential (which is an electrostatic field). Measuring eye position with direct current is usually called electro-oculography (EOG); measuring eye movements, which is the best use of the method, uses alternating current and is usually called electronystagmography (ENG). Potential differences resulting from muscle movement can interfere with eye-movement measurements.

- **Limbus boundary or pupil tracking:** Tracking the movement of the limbus boundary, which is the boundary between the iris and the sclera, provides a measure of horizontal movements. Tracking the pupil is suggested for tracking horizontal or vertical eye movements. Tracking may be done by scanning (e.g., using a television camera with adequate sensitivity) or by differential reflection (e.g., using two photocells).

Key References

1. Collewijn, H., vander Mark, F., & Jansen, T. C. (1975). Precise recording of human eye movement. *Vision Research*, 15, 447-450.
2. Cornsweet, N., & Crane, H. D.

(1973). An accurate eye tracker using first and fourth Purkinje image. *Journal of the Optical Society of America*, 63, 921-928.

3. Eizenman, M., Frecker, R. C., & Hallett, P. E. (1984). Precise

noncontacting measurement using the corneal reflex. *Vision Research*, 24, 167-174.

4. Hallett, P. E. (1986). Eye movements. In K. R. Boff, L. Kaufman, & J. P. Thomas (Eds.), *Handbook of perception and human perfor-*

mance: Vol. 1. Sensory processes and perception. New York: Wiley

5. Young, L. R., & Sheena, W. S. (1975). Survey of eye movement recording methods. *Behavior Research Methods and Instrumentation*, 7, 397-429.

Cross References

- 1.903 Coordinate systems for describing eye movements;
- 1.905 Summary of eye movements according to direction and axis of rotation

Notes

1.905 Summary of Eye Movements According to Direction and Axis of Rotation

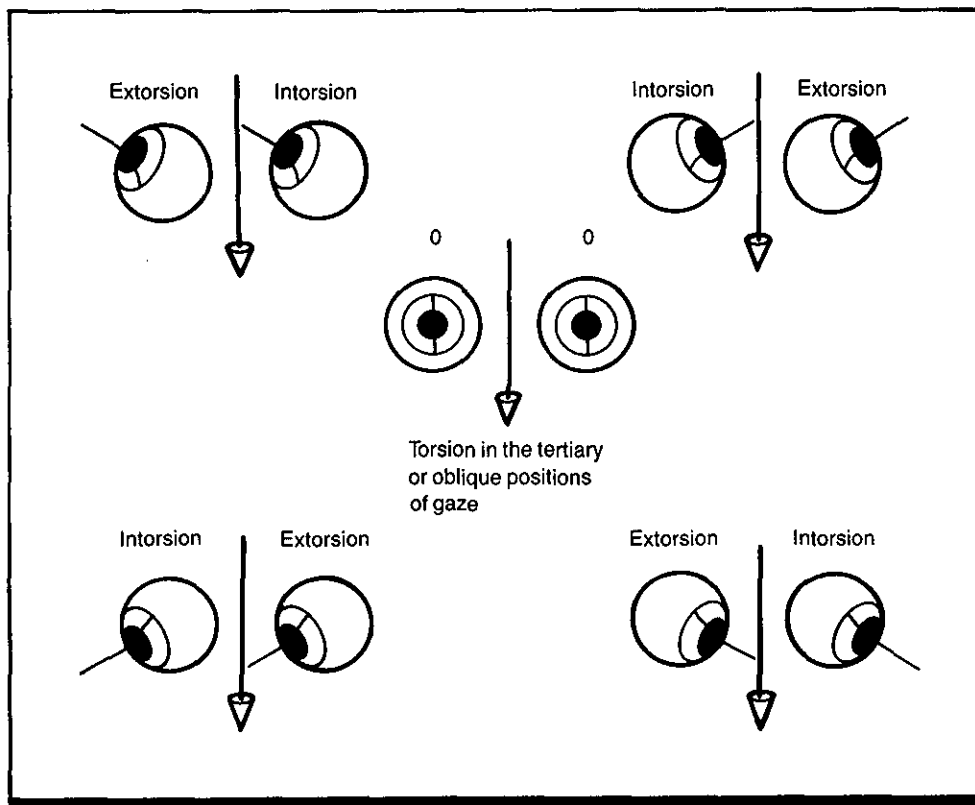

Figure 1. The position of the eyes as they move in false torsion. (From Ref. 1)

Key Terms

Compensatory eye movements; convergence; involuntary eye movements; pursuit eye movements; saccadic eye movements; torsional eye movements; vergence eye movements; visual fixation

General Description

Movement of the eye in the horizontal and vertical planes is effected by the mechanics of the eye's three complementary muscle pairs (CRef. 1.901), with certain directions of movement traversed theoretically with less energy expenditure than others (CRef. 1.902) and at varying speeds

(CRefs. 1.906, 7.504). Conjugate voluntary eye movements (in which both eyes move in the same direction) are used in pursuit of visually fixated objects in the transverse plane. Convergent and divergent eye movements are used to view objects moving toward or away from the observer.

Key References

1. Moses, R. A. (Ed.). (1981). *Adler's physiology of the eye: Clinical application* (7th ed.). St. Louis: C. V. Mosby.

Cross References

1.901 Anatomy and mechanics of eye movements;
1.902 Muscular control of the eyes;
1.903 Coordinate systems for describing eye movements

1.906 Classification of eye movements;
Handbook of perception and human performance, Ch. 10, Sect. 1.1

Table 1. Summary of eye movements according to direction and axis of rotation.

Abduction	Horizontal rotation around vertical axis of Fick (CRef. 1.903), with anterior of eye rotating temporally (outward)
Adduction	Horizontal rotation around vertical axis of Fick, with anterior of eye rotating nasally (inward)
Elevation/Depression	Vertical rotation around horizontal axis of Helmholtz (CRef. 1.903) when anterior of eye moves up/down
True Torsion	Rotation of the eye around the foveal line of sight. True torsion is not usually voluntary. It occurs as a compensatory movement to labyrinthine and tonic neck reflex arcs but may be trained. It compensates for small movements of the head to keep vertical meridians of the retina perpendicular to the horizon
False Torsion	Rotation of the vertical meridian of the eye relative to the vertical planes through the Fick meridians (i.e., vertical planes whose intersection passes through the center of the eye)
Extorsion	False torsion with right eye moving right and up or left and down and left eye moving left and up or right and down
Intorsion	False torsion with right eye moving right and down or left and up and left eye moving left and down or right and up
Translation	Sight movement of the eyeball in its socket which is not necessarily related to voluntary movements during fixation
Vergence/Disjunctive Movements	Movement of eyes in opposite directions. Vertical divergence refers to opposite vertical eye movements; it is a rare condition
Version/Conjugate Movements	Movement from primary to secondary positions by abduction, adduction, elevation, or depression, there being no change in the parallelism or convergence of the two eyes

1.906 Classification of Eye Movements

Key Terms

Abrupt eye movements; conjugate eye movements; corneal reflection; disjunctive eye movements; pursuit eye movements; saccadic eye movements

General Description

An observer of a visual scene exhibits varied eye movements according to the nature of the pattern being viewed. In general, these eye movements fall into arbitrary but convenient categories and subcategories. The first division is between abrupt and smooth movements. All abrupt move-

ments and some smooth movements proceed with the eyes moving in the same direction (conjugate); in some smooth movements, the eyes move in opposite directions (disjunctive). These categories can be further subdivided according to speed of movement (Table 1). The movements can also be described in terms of the type of force.

Applications

Considerations of eye movements are important when an observer is required to track moving objects visually, particularly when those objects may show either regular or irregular velocities or when they are visible constantly versus intermittently.

Methods

Test Conditions

- Eye movements recorded via corneal reflection method (CRef. 1.904) in an otherwise darkened room
- For step patterns and pulse patterns, two small neon light sources on a dark, homogeneous background presented at different positions on an arc of 150-cm radius concentric with observer's head; offset of one light synchronous

- with or at different intervals with respect to onset of second light
- For movement conditions, small spot of light moved across cylindrical screen with 150-cm radius (as for step patterns)
 - Observer's head stationary via a bite board; observer unaware of expected nature of apparent movement and timing for stimuli
 - Six types of target patterns:
 1. Step patterns: offset of first light synchronous with onset of second

2. Pulse patterns: brief temporal gap between offset of first and onset of second lights, and then subsequent return to original position; time gap from 40-500 msec
3. Constant velocity movement: horizontal movement with constant angular velocity
4. Predictable movement: horizontal movement controlled by trigonometric sine function
5. Unpredictable movement: light often changed velocity and/or reversed directions
6. Intermittent presentation: same as constant velocity movement, but

target exposed for only 10 msec of each 120 or 240 msec

Experimental Procedure

- Independent variables: type of target pattern, speed of movement of stimulus across visual field
- Dependent variable: observer responses to changes in location and timing of displayed lights
- Observer's task: fixate on lights presented to visual field
- 3 young adults with normal vision

Experimental Results

- Abrupt, saccadic movement always require (at least) ~150 msec to begin; eye movements persist for ~100 msec after cessation of movement or disappearance of light.
- Step pattern results: response is always saccadic eye movement, with one or more corrective saccades, if necessary.
- Pulse patterns: two saccades always occur, even if the target has already returned to its original position before the first saccadic movement has begun.
- Constant velocity target movement: with target velocities of 25-30 deg/sec, an initial saccade brings about fixation on the target and then smooth movements of target velocity are used to track the stimulus. Occasional small saccades are superimposed on the tracking movement of the eye. With target velocities of >30 deg/sec, corrective saccades are often needed to reduce the discrepancies between actual position of the light and the fixation point.

- Unpredictable target movement: smooth tracking movements and saccadic movements both occur; changes in tracking speed occur at intervals >100 msec and are associated with small saccades. The lag between major changes in target velocity and changes in tracking velocity is ~150 msec.
- Predictable target movement: observers initially show responses similar to tracking of unpredictable movement, but after learning occurs, eye movements are similar to target movements. Sometimes changes in eye velocity may precede changes in target velocity.
- Intermittent target presentation: observer's eye movements are similar to those for smooth movement of a continuously presented light, although saccadic corrections are used to reduce discrepancy between fixation and actual light position; such discrepancies occur more frequently than with continuously presented stimuli.

Variability

No information on variability was given.

Table 1. Types of eye movements and associated stimuli. (From Ref. 1)

Type of Eye Movement	Stimulus	Effect	Speed
Smooth pursuit	Slowly moving object	Track slowly moving objects	Slow, usually only up to 40 deg/sec
Saccade	Either peripherally detected motion or decision to change fixation	Examine new targets, visual search	Very fast, up to 1000/deg/sec
Vestibulo-ocular	Head or body motion	Maintenance of fixation during head or body movement	As appropriate, may reach 500 deg/sec
Vergence	Retinal disparity	Maintain convergence of both eyes on same fixated target	Very slow, up to 10 deg/sec
Drift	Spontaneous	Maintain fixated detail close to foveal center. Maintain stimulation of photoreceptors and retinal neurons.	Moderate, up to 4 min arc/sec and very small
Microsaccade (flick)	Prior drift. Psychological ("busy work")	Reposition the eye with respect to previous fixation	Very fast, like saccade, and very small
Physiological nystagmus (tremor)	Irreducible muscle imbalance	Random	Very fast and very small

Constraints

- This discussion does not make reference to any lower-level reflexive eye movements (e.g., vestibulo-ocular movements).
- This discussion does not include potential eye movements for apparent motion (i.e., phi phenomenon).

Key References

1. Haber, R. N., & Hershenson, M. (1980). *The psychology of visual perception*. New York: Holt, Rinehart & Winston.

*2. Westheimer, G. (1954). Eye

movement responses to a horizontally moving visual stimulus. *AMA Archives of Ophthalmology*, 52, 932-941.

3. Westheimer, G. (1957). Kinematics of the eye. *Journal of the*

Optical Society of America, 47, 967-974.

4. Westheimer, G. (1971). Discussion of the control of eye movements. In P. Bach-y-Rita, C. C.

Collins, & J. Hyde (Eds.), *The control of eye movements*. New York: Academic Press.

5. Yarbus, A. L. (1967). *Eye movements and vision*. (B. Haigh, Trans., & L. A. Riggs, Ed.) New York: Plenum.

Cross References

1.901 Anatomy and mechanics of eye movements;

1.904 Methods of measuring eye movements

1.907 Adaptability of Eye Movements

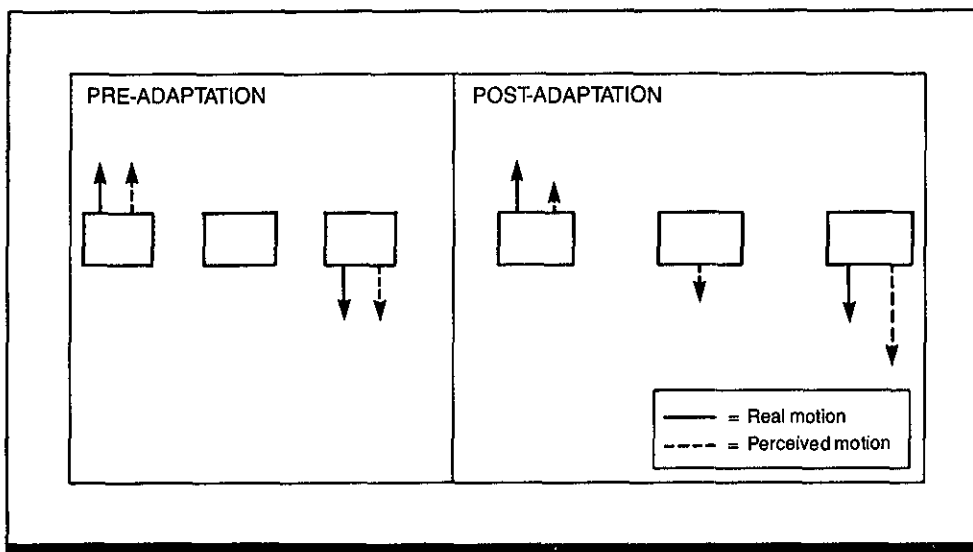

Figure 1. Perceived and actual motion before and after adaptation. Before adaptation to a square that moves up as eyes move right, motion and stationarity are perceived accurately. After adaptation, upward motion is seen as less than it is, stationarity is perceived as downward motion, and downward motion is enhanced. The middle position in pre- and post-adaptation sides of figure represents stationarity.

Key Terms

Adaptability; saccadic eye movements; visual fixation; visual position constancy

General Description

Normally, the retinal image of a stationary object moves to the left as the eye moves to the right, and the object is perceived as stationary. If the stimulus moves vertically as the observer makes a lateral saccade (eyes jump from one posi-

tion to another) the observer initially sees stimulus motion. After adaptation to this altered relationship between eye and retinal image motion, position constancy is re-established (the vertically moving object comes to be perceived as stationary).

Applications

Environments where there is an altered relation between eye and/or head motion and retinal displacement.

Methods

Test Conditions

- Uniformly-lit square subtending visual angle of 0.5 deg, positioned to coincide with subjective straight ahead, shown midway between two briefly flashed horizontal points separated by 6 deg on a fast-phosphor CRT
- Observer's head position secured by rigid bite plate
- Eye movements monitored by a Purkinje image eyetracker, whose output was adjusted so that each 3-deg horizontal excursion of

observer's eye to left or right produced a 1.5-deg upward or downward displacement of square; experimenter could adjust the vertical motion of the square from its maximum calibrated value of 50% down to 0% in 23 uniform steps of 2.17% each.

- Pre-exposure threshold determined by having observer saccade between two briefly flashed points, at first while square was stationary, and later as it was moved up and down in successive increments of 2.17% of the horizontal saccadic distance; when observer reported vertical motion in correct direction on three successive trials, threshold

was recorded as first of these trials and a descending series was begun; two ascending and two descending series were conducted

- Post-exposure threshold determined similarly, but with only one ascending and one descending series
- Adaptation period (between threshold determinations); observer had to saccade to left and right of stimulus square in time with a 0.5-Hz sequence of audible clicks in absence of flashed points as square was displaced vertically by 26.04% of horizontal distance of the saccade, for 90 sec, rested

for 60-sec, and then repeated the procedure for 30 such periods.

Experimental Procedure

- Up and down motion trials presented randomly, with no-motion trials intermixed (~1 per 10 trials)
- Independent variable: up or down motion of the square dependent on, respectively, right or left motion of the eyes
- Dependent variable: difference between the pre- and post-adaptation thresholds
- Observer's task: saccade to and from flashing squares, as directed
- 8 observers with normal uncorrected vision

Experimental Results

- If square moved up when observer looked right and down when observer looked left during adaptation, then threshold for perceiving upward motion significantly increases (mean of 7.8%), and the threshold for perceiving downward motion significantly decreases (mean of 6.4%), while observer saccades right; opposite is true when observer saccades left. These results indicate that upward motion begins to be perceived as stationary, or of lesser magnitude, and is therefore harder to see, while the criterion for downward motion is correspondingly recalibrated, resulting in its being seen more easily when eyes move to the right.

- When observer is required to move the eyes horizontally, observer moves them obliquely, in comparison to pre-exposure eye movements with same instructions.

Variability

No information on variability was given.

Repeatability/Comparison with Other Studies

A similar modification of eye movements can result from laterally changing the position of the target to which the saccade is directed (Ref. 3). Head movements and altered retinal image displacements have been similarly recalibrated.

Constraints

- It is not yet known if complete adaptation to an altered relation between eye and/or head movement and altered image movement can occur.
- A considerable number of subjects were eliminated during trials because they could not adequately perform task

(i.e., could not saccade ~6 deg between flashes, could not hold eyes steady between flashes, or could not control impulse to saccade to the square). Perhaps this task is too unrealistic to assess adaptability of eye movements.

Key References

1. Hay, J. (1968). Visual adaptation to an altered correlation between eye movements and head movements. *Science*, 160, 429-430.

*2. Mack, A., Fendrich, R., & Pleune, J. (1978). Adaptation to an altered relation between retinal image displacements and saccadic eye movements. *Vision Research*, 18, 1321-1327.

3. McLaughlin, S. C. (1967). Parametric adjustment in saccadic eye movements. *Perception & Psychophysics*, 2, 359-361.

Cross References

1.904 Methods of measuring eye movements;

1.908 Effect of fatigue on eye movements

1.908 Effect of Fatigue on Eye Movements

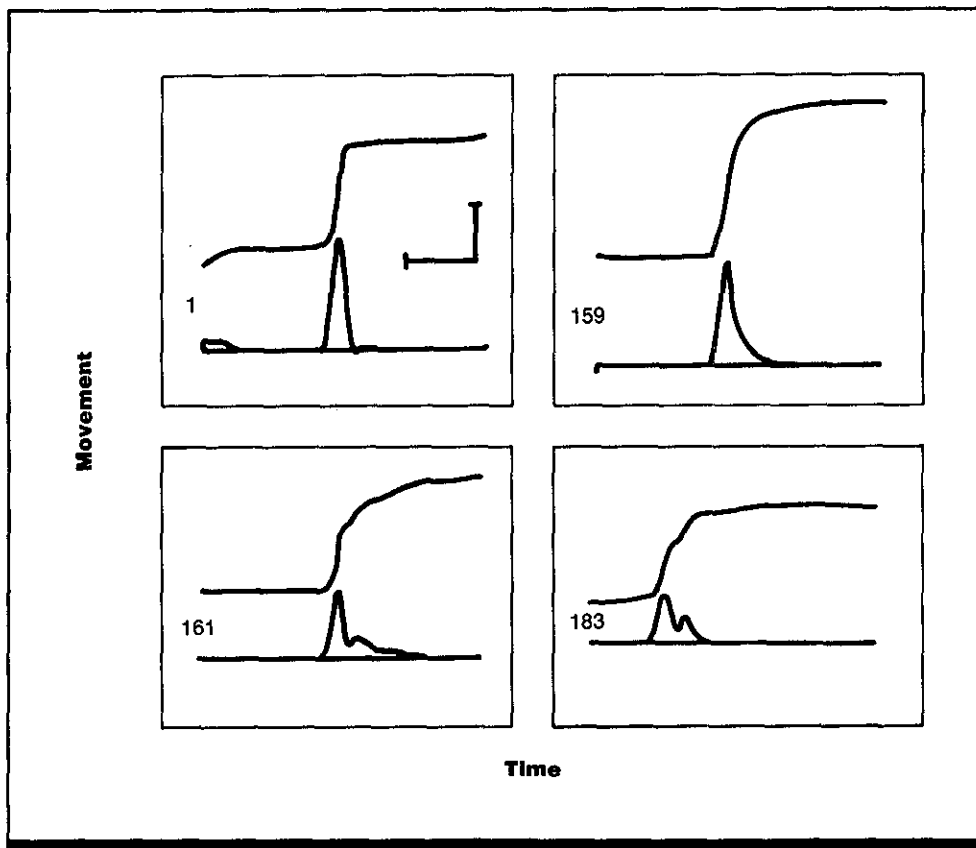

Figure 1. Eye position (upper curves) and eye velocity (lower curves) as functions of time for four saccades in temporal sequence. The first recorded saccade of the day, coded "1," is normal. The 159th fell short of its final position and was completed by a glissade; saccade "161" took eye only halfway to normal position but was normal in velocity. Two overlapping saccades are shown in "183." The calibrations represent 5 deg, 250 deg/sec, and 100 msec. (From Ref. 1)

Key Terms

Fatigue; glissades; saccadic eye movements; visual fixation

General Description

Visual fatigue in observers leads to anomalous patterns of eye movement, resulting in overlapping saccades, post-saccade glissades (slow drifting eye movements), and low-velocity, long-duration saccades. Large-magnitude saccades produce fatigue more quickly and completely than do smaller saccades.

Applications

Tasks requiring a sensitive index of fatigue. Environments where accurate fixation is required.

Methods**Test Conditions**

- Targets for small saccades (≤ 25 deg) were 1-mm diameter spots of light produced by a slide

projector, reflected off mirror galvanometer, and presented on semicircular screen 46 cm from observer; pieces of white tape were targets for larger eye movements

- Observer's head steadied by head rest and bite bar

Experimental Procedure

- Independent variables: size, number of saccades observer required to make

- Dependent variables: eye movement magnitude, velocity, pattern
- Observer's task: saccade between targets 40 saccades/min (0.33 Hz)
- Number of observers not specified

Experimental Results

- When observer is fatigued, glissades (monocular) appended to end of fast saccadic portion of eye movement occur more often, the number of overlapping saccades (monocular) increases, as does the occurrence of low-velocity, long-duration saccades, which often occur when the observer attempts to make a smaller saccade after being fatigued by making larger ones.
- Fatigue decreases the percentage of saccades with dynamic overshoot, but increases the frequency of saccades having an abnormally large amount of dynamic overshoot.
- For a typical observer, after 500 saccades of 10-deg magnitude, fixations become less accurate, with more corrective

and double saccades. Still, the observer responds to instructions to be more accurate and, after 1200 saccades, can still saccade accurately, although speed is reduced.

- Large saccades are much more fatiguing: thirty 50-deg saccades or eighty 30-deg saccades make an observer incapable of normal saccades. Change from larger to smaller size of required saccades restores saccade accuracy temporarily, but this effect does not apply when changing from smaller to larger saccades.

Variability

No information on variability was given.

Repeatability/Comparison with Other Studies

Other studies (Refs. 3, 4, 5) have reported eye movements comparable to those reported here (Ref. 1).

Constraints

- Factors other than fatigue may increase the occurrence of eye movements that are not in the normal range.

Key References

*1. Bahill, A. T., & Stark, L. (1975). Overlapping saccades and glissades are produced by fatigue in the saccadic eye movement system. *Experimental Neurology*, 48, 95-106.

2. Dell'Osso, L. F., Daroff, R. B., & Troost, B. T. (1973). Reply to "A comment on the 'glissade'" (Letter to the editor). *Vision Research*, 13, 883-884.

3. Miles, W. R. (1936). The reac-

tion time of the eye. *Psychological Monographs*, 47, 268-293.

4. Täumer, R. (1975). Three reaction mechanisms of the saccadic system in response to a double jump. In G. Lennerstrand & P. Bach-y-Rita (Eds.), *Basic mechanisms of ocular motility and their*

clinical implications (pp. 515-518). Oxford: Pergamon Press.

5. Weber, R. B., & Daroff, R. B. (1972). Corrective movements following refixation saccades: Type and control system analysis. *Vision Research*, 12, 467-475.

Cross References

1.901 Anatomy and mechanics of eye movements;

1.932 Factors influencing the latency of saccades

1.909 Maladaptive Eye Movements: Eliciting Conditions

Key Words

Latency; maladaptive eye movements; nystagmus; saccadic eye movements; visual fixation

General Description

Under tranquil conditions, performance is not dangerously affected by underreaction in eye movements to task instructions. Because most eye movements are <15 deg in

amplitude, underestimating the movement by ~10%, with the head in a fixed position, still leaves the stimulus close to the fovea. Other situations, however, do elicit inappropriate eye movements, as summarized in the table.

Constraints

- There may be other situations not listed.
- The inaccuracy of the primary saccade, when an observer is instructed to look away from a target, is often corrected, at least partially by a secondary saccade.

Key References

1. Carpenter, R. H. S. (1981). Oculomotor procrastination. In D. F. Fisher, R. A. Monty, & J. W. Senders (Eds.), *Eye movements: Cognition and visual perception* (pp. 237-246). Hillsdale NJ: Erlbaum.
2. Haddad, G. M., & Winterson, B. J. (1975). Effect of flicker on

oculomotor performance. In G. Lennerstrand & P. Bach-y-Rita (Eds.), *Brain mechanisms of ocular motility and their clinical implications*. Oxford, England: Pergamon.

3. Hallett, P. E. (1978). Primary and secondary saccades to goals defined by instructions. *Vision Research*, 18, 1279-1296.

4. Hallett, P. E., & Adams, B. D. (1980). The predictability of saccadic latency in a novel voluntary oculomotor task. *Vision Research*, 20, 329-339.

5. Mack, A., Fendrich, R., & Wong, E. (1982). Is perceived motion a stimulus for smooth pursuit? *Vision Research*, 22, 77-88.

6. Melvill Jones, G. (1965). Vestibulo-ocular disorganization in the

aerodynamic spin. *Aerospace Medicine*, 36, 976-983.

7. Steinman, R. M., & Cunitz, R. J. (1968). Fixation of targets near the absolute foveal threshold. *Vision Research*, 8, 277-286.

8. Zeevi, Y. Y., & Peli, E. (1979). Latency of peripheral saccades. *Journal of Optical Society of America*, 69, 1274-1279.

Cross References

- 1.907 Adaptability of eye movements;
- 1.915 Effects of target characteristics on eye movements and fixation;

1.937 Voluntary control of saccadic eye movements;

9.102 Simple reaction time to visual targets of different luminances;

Handbook of perception and human performance, Ch. 10, Sect. 2.1

Table 1. Situations that elicit apparently inappropriate or inefficient eye movements.

Instructions to Observer	Resulting Eye Movement	References
Track a small, bright spot against a dark background	Saccadic latencies are longer than the duration of the saccade.	Ref. 1
Fixate a stimulus whose luminance is below foveal threshold	Smooth eye movements repeatedly bring targets to the foveal region, where they can no longer be seen.	Ref. 7
Fixate under flickering lighting	Fixation stability disrupted.	Ref. 2
Follow movements of a target after being in a spinning aircraft	Post-rotary nystagmus results, and can induce dizziness and disorientation.	Ref. 6
Look away from a target displacement by an equal and opposite amount	Angular errors of primary saccades are about twice that of saccades toward target; mean latency is twice the normal mean latency minus 144 msec; performance shows little or no improvement with practice.	Refs. 3, 4 CRef. 1.937
Superpose a point that indicates an eye area other than the fovea on a target	Initial eye-movement latency is about twice that of foveating saccades but improves with practice to about normal levels.	Ref. 8 CRef. 1.937
Shift eccentric fixation (i.e., fixating with eye area other than fovea) to follow a stepping target	Observer must foveate stimulus before doing this.	Ref. 8 CRef. 1.937
Pursue object moving behind a fixed slit	Some smooth pursuit errors	Ref. 5

Notes

1.910 Control-Systems-Analysis Model of Visual and Oculomotor Functions in Retinal Image Stabilization

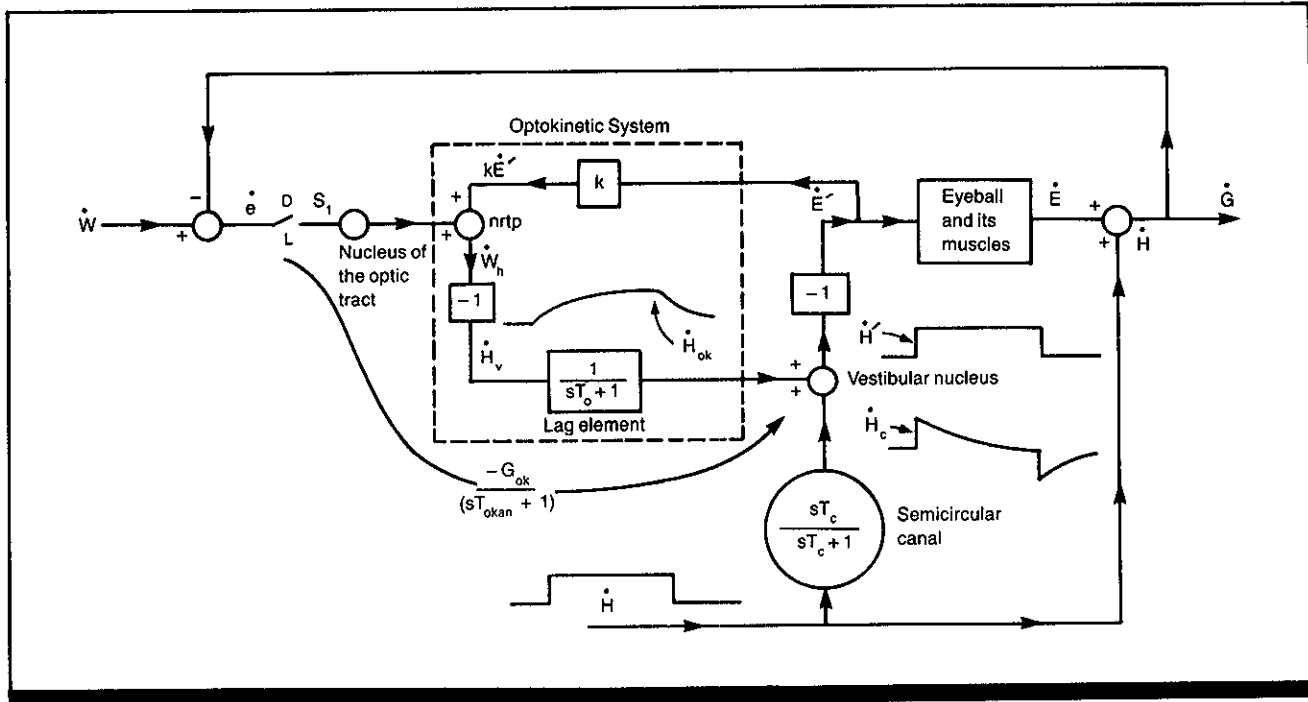

Figure 1. General model for the optokinetic system (OKS) and its connection with the vestibulo-ocular reflex (VOR); one specific model of the OKS is contained in the dotted square. The OKS (in conjunction with the VOR) attempts to keep eye velocity in space (\dot{G}) equal to the velocity of the visual world (\dot{W}) regardless of head rotation; retinal slip velocity \dot{e} is the error signal. Input is velocity of the visual world (\dot{W} , which equals 0 for a stationary environment) and head velocity in space (\dot{H}); output is eye velocity in space (\dot{G}), which is the sum of eye velocity in the head (\dot{E}) and head velocity in space (\dot{H}). As measures of head velocity, the output (\dot{H}_{ok}) of the OKS is the primary signal during constant-velocity head rotation and the output (\dot{H}_c) of the semicircular canal is the primary signal during transient activity. The nucleus reticularis tegmenti pontis (nrtp) is a particular nucleus in the brain; \dot{E} is an internal efference copy (corollary discharge signal) of eye velocity \dot{E} ; \dot{W}_h is the nervous system's estimated velocity of the world with respect to the head; \dot{H}_v is the visual system's estimate of head velocity (which equals $-\dot{W}_h$ because the nervous system expects the visual world to be stationary—under conditions where the visual world is nonstationary, such as laboratory situations involving a rotating drum, this can result in an illusion of self-rotation known as circularvection after a period of time consistent with the washout dynamics of the canal); \dot{H}' is the output signal of the vestibular nucleus (\dot{H}' equals $\dot{H}_c + \dot{H}_{ok}$ and approximates \dot{H}); G_{ok} is the gain (normally about 3 to 5) and T_{okan} the time constant (normally about 15 to 20 sec) of the \dot{e} to \dot{H}_{ok} forward transfer function (the subscript *okan* refers to optokinetic after-nystagmus); k is the OKS loop gain constant (normally about 0.6 to 0.8); T_o is the optokinetic time constant and T_c is the semicircular-canal time constant; s is the Laplace transform complex frequency; and S_1 is a switch which closes the feedback path from \dot{G} if the environment is in the light (position L) or opens it in the dark (position D). (Reproduced, with permission, from the *Annual Review of Neuroscience*, Vol. 4. © 1981 by Annual Reviews Inc.)

Key Terms

Corollary discharge; eye-movement control; eye-head coordination; nystagmatic gain; oculomotor control; optokinetic nystagmus; retinal image stabilization; semi-circular canals; vestibulo-ocular reflex

General Description

Robinson's control-systems-analysis model (Ref. 4) predicts eye velocity required to stabilize the retinal image when it would be perturbed by head and environmental movements. This model is based on the widely accepted notion that the optokinetic system (OKS) functions to supplement the signal from the semicircular canals in the low-frequency region where the canals are no longer effective. This system attempts to maintain angular eye velocity in space (\dot{G}) equal to the angular velocity of the visual world

(\dot{W}) by minimizing retinal slip (\dot{e}). The OKS includes a **corollary-discharge** positive-feedback path to augment the canal dynamics at low frequencies. A first-order lag (time constant T_o) removes high-frequency components from this signal.

The model relates retinal slip and head velocities to eye velocity using the formulas:

$$\dot{H}_c/\dot{H} = sT_c/(sT_c + 1)$$

for the semicircular canal transfer function, and

$$\dot{H}' = \dot{H}_c + \dot{H}_{ok} = \frac{sT_c}{sT_c + 1} \dot{H} + \frac{1}{sT_o + 1} \dot{H}_v$$

to represent the nervous system's estimate of head velocity obtained by combining canal response with optokinetic feedback in the vestibular nucleus. For humans, T_c has a nominal value of roughly 7 sec (although a fairly wide range of values have been reported, as summarized by Ref. 5). In order that the OKS dynamics complement the frequency range of the canals, T_o is nearly equal to T_c . The symbols are as defined in the caption of Fig. 1.

Applications

The model can be used as an aid to understand how the optokinetic and vestibular systems interact, and to investigate changes in parameters, such as nystagmic gain. It can be useful as a research tool for proposing various hypotheses of oculomotor and visual function that can be tested experimentally.

Empirical Validation

The model has been tested by comparing predicted values with empirical measurements. The following eye movement functions are accurately simulated in the linear range:

- The vestibulo-ocular reflex, which causes an eye rotation in the opposite direction of a head rotation (Fig. 2);
- Pursuit eye movements;
- Optokinetic eye movements;
- Various normal combinations of the above; and
- Conflict combination of pursuit and optokinetic eye movements (Fig. 3).

Constraints

- The model does not deal with nonlinearities (Ref. 2).
- Other factors such as fatigue, attention, and prior knowledge of target location may produce results in the real oculomotor system that are not predictable by this model.
- The model does not allow for the role of intervestibular interactions in the control of vestibular nystagmus (Ref. 1).
- The model describes what signal processing is being done at a higher level of organization in which relatively simple neural networks are represented by transfer functions. It does not describe how this signal processing is done at the neural level.

Key References

1. Galiana, H. L., & Outerbridge, J. S. (1984). A bilateral model for central neural pathways in vestibulo-ocular reflex. *Journal of Neurophysiology*, 51, 210-241.
2. Henn, V., Cohen, B., & Young, L. R. (1980). Visual-vestibular interactions in motion perception and the generation of nystagmus. *Neurosciences Research Program Bulletin*, 18, 575-651.
3. Robinson, D. A. (1977). Vestibular and optokinetic symbiosis: An example of explaining by mo-

delling. In R. Baker & A. Berthoz (Eds.), *Control of gaze by brainstem neurons. Developments in Neuroscience Vol. 1*. Amsterdam: Elsevier/North Holland Biomedical Press.

4. Robinson, D. A. (1981). The use of control systems analysis in the neurophysiology of eye movements. *Annual Review of Neuroscience*, 4, 463-503.

5. Zacharias, G. L. (1978). Motion cue models for pilot-vehicle analysis (AMRL-TR-78-2). Wright-Patterson AFB, OH: Aerospace Medical Research Laboratories. (DTIC No. ADA061477)

Cross References

- 1.913 Visual fixation: relationship between head and eye movements;
1.915 Effects of target characteris-

tics on eye movements and fixation;

- 1.916 Visual fixation on dimly illuminated targets

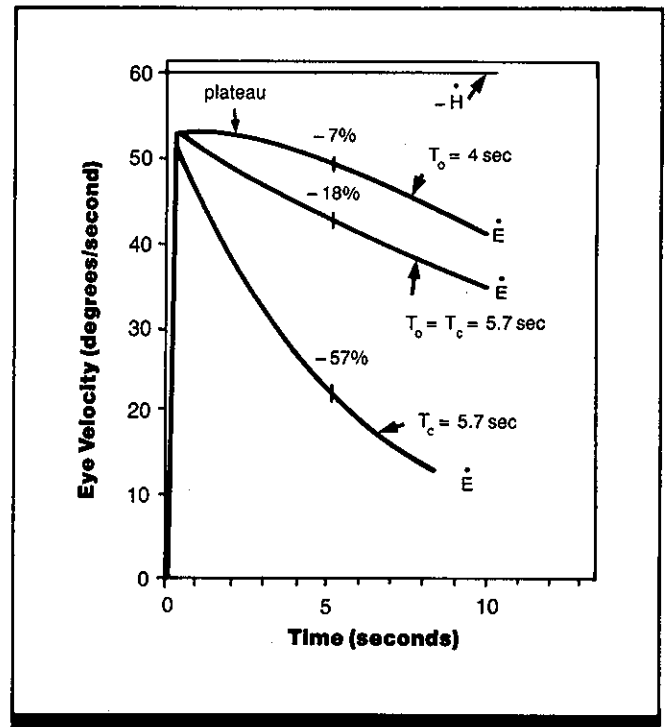

Figure 2. Model's simulation of vestibulo-ocular response (VOR) with a step rotation of head velocity (\dot{H}) of 60 deg/sec in the dark (i.e., S_1 in Fig. 1 is open); shows how the presence of the eye-velocity feedback loop ($k\dot{E}$) greatly enhances the VOR response. The lowest curve is with the semicircular-canal signal only; the middle curve shows the effect of adding the optokinetic loop (within the OKS dashed outline in Fig. 1). The top curve shows the consequence of deliberately mismatching the values of T_o (the optokinetic time constant) and T_c (the semicircular-canal time constant) so that the characteristic plateau (assumed to be the usual biological response) is observed. The canal response was set to mimic that of a monkey ($T_c = 5.75$) in this case. (From Ref. 2)

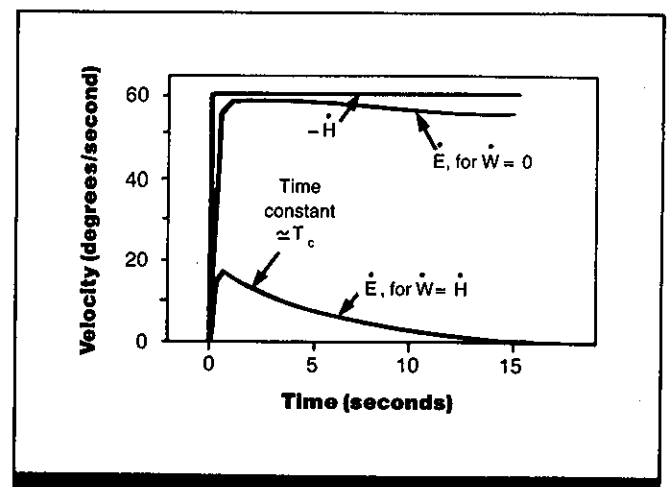

Figure 3. Model's simulation for observer's rotation (60 deg/sec) in the light with a stationary visual surround (top curve) and with observer and visual world moving at same velocity (bottom curve). \dot{H} indicates head velocity in space; \dot{E} indicates eye velocity in the head; and \dot{W} indicates the velocity of the visual world (a stationary or rotating drum for the top and bottom curves, respectively). (From Ref. 2)

1.911 Visual Fixation Stability in the Dark

Key Terms

Drifts; eye movement control; fixation stability; monitoring; visual fixation

General Description

When an observer fixates on a target, the drift of the eye from the fixation point is small. When the target is removed and the observer maintains fixation in darkness, fixation error increases with time. Fixation stability decreases immediately after the target is removed; an increased variability level is maintained throughout the dark period. This finding suggests a deterioration of spatial memory rather than a loss of eye-movement control.

Applications

Controls, displays, and environments requiring steady fixation and memory for target locations.

Methods**Test Conditions**

- Target disk of tungsten-white light (0.44 cd/m^2), 16 min arc of visual angle diameter, located 0.75 m from observer's right eye; left eye covered; target placed straight ahead of observer or 10 deg to right or left of straight ahead position; observers instructed to keep eye in constant position
- Observer initiated each trial, which consisted of 10-sec fixation of target followed by 38 sec of total darkness
- Eye movements recorded using contact lens optical lever technique (Ref 4; CRef. 1.904)

Experimental Procedure

- Independent variable: time in dark
- Dependent variables: distance between mean eye position with target visible and mean eye position in dark (error), standard deviation of eye position; both during successive 7.6-sec periods of darkness
- Observer's task: maintain fixation on spot at which target had appeared
- Four experimental sessions, with total of 24 trials/target position
- 2 observers, both experienced with contact lenses and fixation of visible targets but not experienced at trying to keep eye in place for long periods in total darkness

Experimental Results

- Mean eye position in the dark is displaced 30-40 min arc from positions defined by visible targets.
- Fixation error increases throughout the dark period, but the rate of increase is small (1-2 min arc/sec).
- Immediately after the target is extinguished, fixation stability decreases (variability increases); an increased level of variability is maintained thereafter for >2 min.

Variability

Results are comparable for each target position.

Repeatability/Comparison with Other Studies

Results are consistent with other studies (Refs. 1, 2, 3) re-

Constraints

- Data may not be valid for larger targets, longer periods of darkness, or dim targets (Ref. 5).

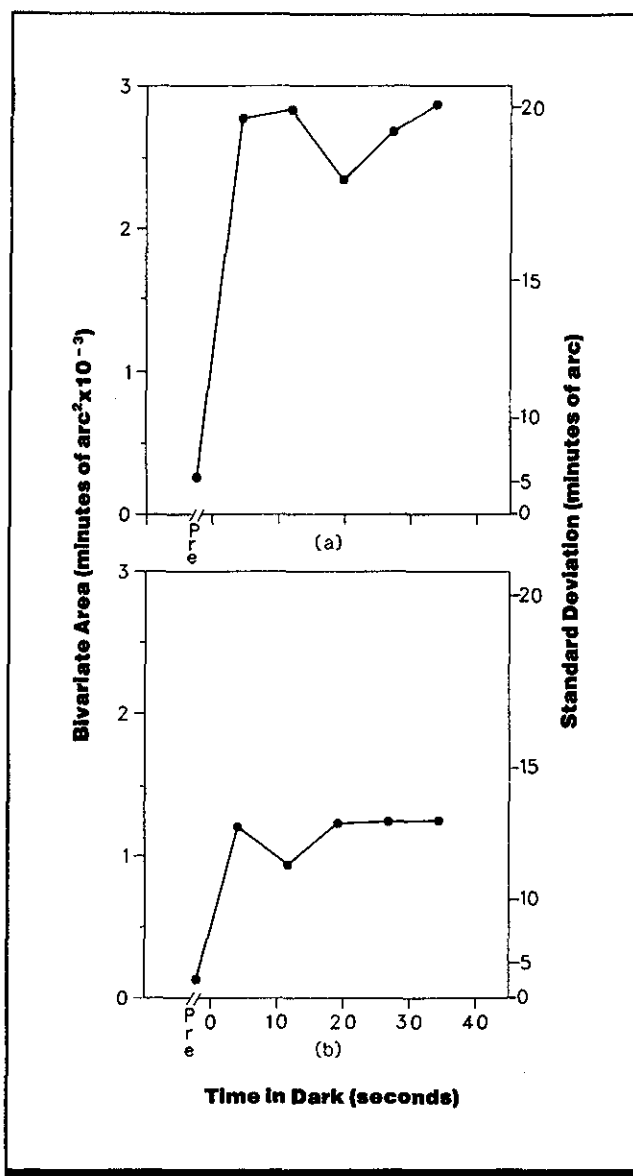

Figure 1. Fixation stability for 2 observers, averaged over three target positions. Left ordinate is the area which contains 68% of eye positions during each 7.6-sec period. Right ordinate is an estimate of the corresponding standard deviation about the mean eye position in each 7.6-sec period. "Pre" represents the period when the target was visible. (From Ref. 4)

porting inability to maintain eye-position control during short periods in the dark.

Key References

1. Cornsweet, T. N. (1956). Determination of the stimuli for involuntary drifts and saccadic eye movements. *Journal of the Optical Society of America*, 46, 987-993.

2. Matin, L., Matin, E., & Pearce, D. G. (1970). Statistical characteristics of eye movements in the dark during the attempt to maintain a prior fixation position. *Vision Research*, 10, 837-857.

3. Nachmias, J. (1961). Determiners of drift of the eye during monocular fixation. *Journal of the Optical Society of America*, 51, 761-766.

*4. Skavenski, A. A., & Steinman, R. M. (1970). Control

of eye position in the dark. *Vision Research*, 10, 193-203.

5. Steinman, R. M. (1965). Effect of target size, luminance, and color on monocular fixation. *Journal of the Optical Society of America*, 55, 1158-1165.

Cross References

1.904 Methods of measuring eye movements;

1.913 Visual fixation: relationship between head and eye movements;

1.914 Monocular fixation on stationary targets;

1.916 Visual fixation on dimly illuminated targets;

7.313 Eye fixations and eye movements during display monitoring;

7.511 Search time and eye fixations: effects of symbol color, size, and shape;

11.403 Target coding: effect on search time;

Handbook of perception and human performance, Ch. 10, Sect. 3.2

1.912 Fixation Stability: Magnitude of Horizontal Drift

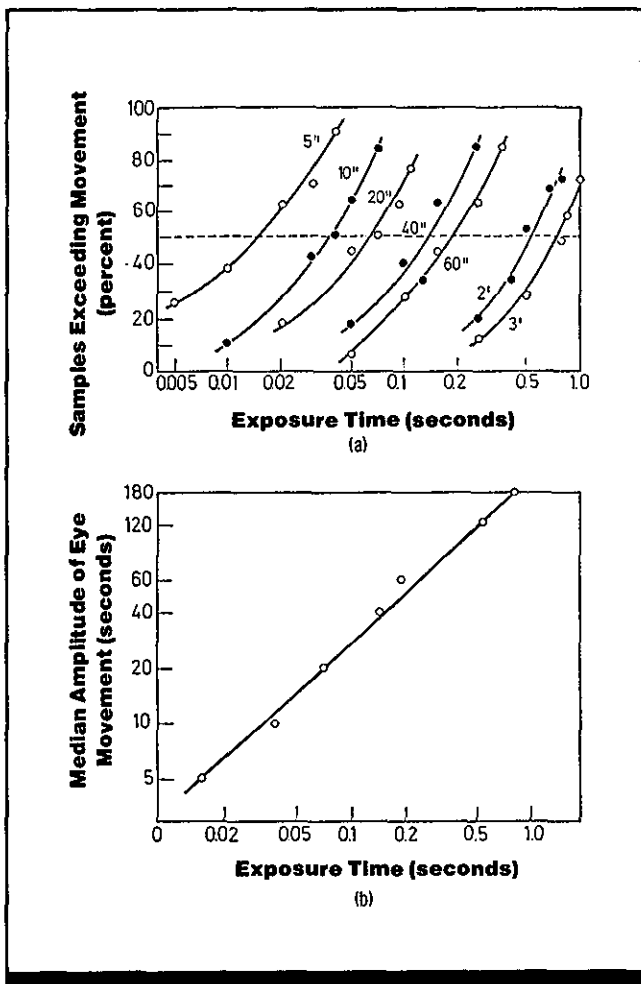

Figure 1. (a) Percentage of eye movement records containing excursions longer than values indicated on curves as a function of length of record. (b) Median extent of eye movement as a function of length of record. (From Ref. 2)

Key Terms

Eye tremor; involuntary eye movements; ocular tremor; visual direction; visual fixation; visual localization

General Description

Eye position is maintained by a dynamic balance of opposing muscular systems; therefore, involuntary ocular tremor occurs, limiting the ability of an observer to maintain a steady gaze. Because excursions from fixation may be

small, a sensitive measuring system is required. A state-of-the-art contact lens system indicates that the eye does indeed drift from the point of fixation and that these excursions increase in amplitude when the time frame for measurement increases (Ref. 2).

Methods

Test Conditions

- Horizontal eye movements recorded by means of contact lens upon which a small mirror was mounted; light reflected from mirror recorded on a moving film strip

- Observer viewed a dark fixation point at the center of a bright field
- Eye movements recorded for 0.005, 0.01, 0.02, 0.03, 0.04, 0.05, 0.07, 0.09, 0.1, 0.14, 0.16, 0.2, 0.3, 0.4, 0.5, 0.7, 0.8, 0.9, or 1 sec
- Head fixed by bite board

Experimental Procedure

- Independent variable: length of eye movement record
- Dependent variable: excursion of eye

Experimental Results

• Figure 1a plots the percentage of eye movement records that show an excursion from fixation exceeding given values. Excursions increase in amplitude with increased length of eye movement record.

• Figure 1b plots the median extent of eye movement (intersections of the dashed 50% line with each curve in Fig. 1a) as a function of length of record. Median amplitude increases linearly with log length of eye movement record.

Variability

No information on variability was given.

Constraints

• Data are available over a longer sampling time. For a 30-sec fixation period, 68% of the time the eye is within 3 min arc of the fixation point (Ref. 1).

Key References

1. Nachmias, J. (1959). Two-dimensional motion of the retinal image during monocular fixation. *Journal of the Optical Society of America*, 49, 901-908.

*2. Riggs, L. A., Armington, J. C., & Ratliff, F. (1954). Motions of the retinal image during fixation. *Journal of the Optical Society of America*, 44, 315-321.

Cross References

1.911 Visual fixation stability in the dark;
1.913 Visual fixation: relationship between head and eye movements;

1.914 Monocular fixation on stationary targets;
1.915 Effects of target characteristics on eye movements and fixation;

1.916 Visual fixation on dimly illuminated targets;

7.313 Eye fixations and eye movements during display monitoring;

11.403 Target coding: effect on search time;

Handbook of perception and human performance, Ch. 20, Sect. 3.4

1.913 Visual Fixation: Relationship Between Head and Eye Movements

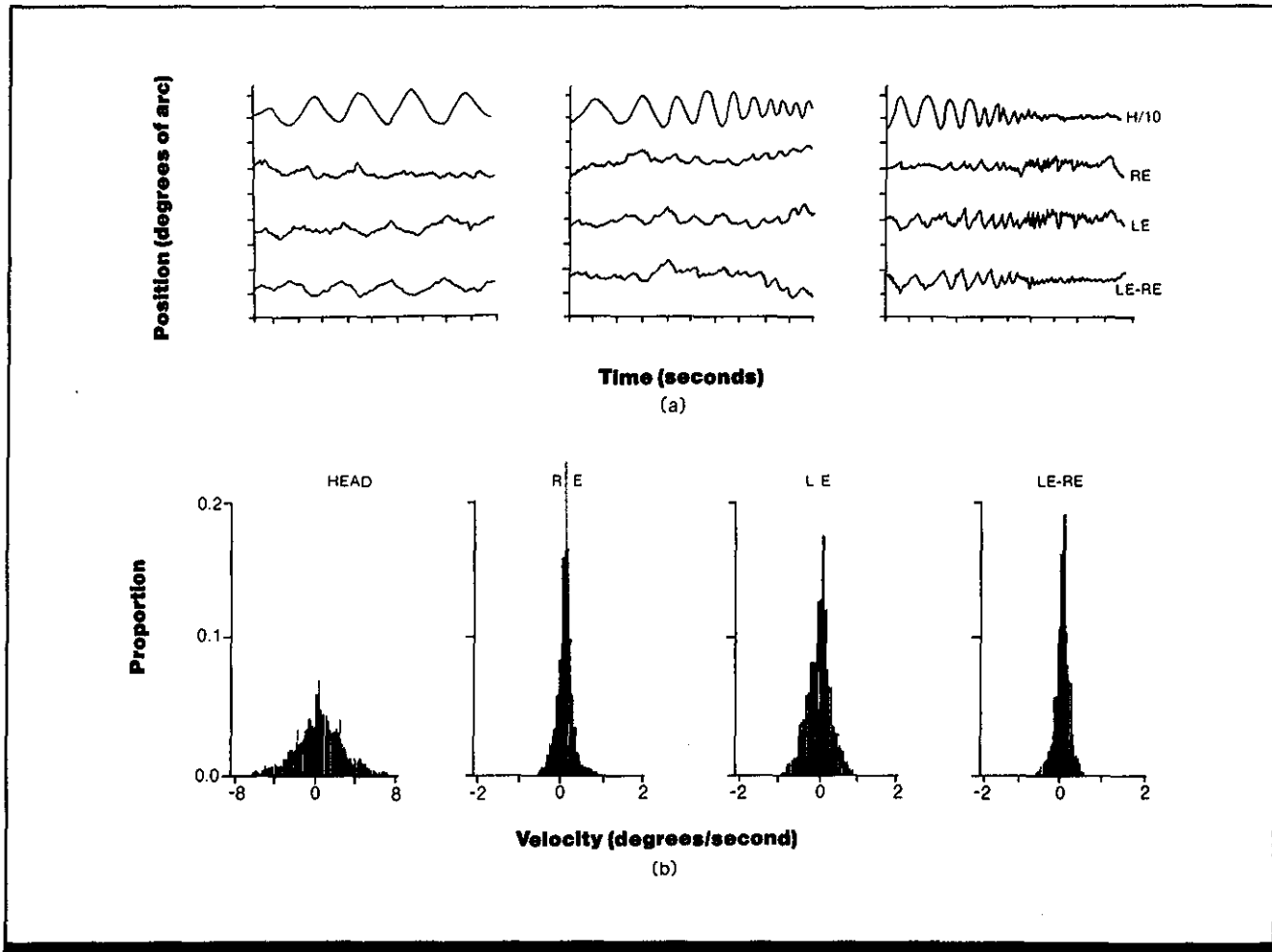

Figure 1. (a) Representative horizontal eye and head movement records of one observer. H/10 represents head position scaled down ten times, RE and LE are right and left eye positions, respectively (right movement upwards), and LE-RE is the difference in position of left and right eye vergence. Time-scale marks signify scale marks, 1 deg distances. (b) Horizontal velocity histograms for one observer during head movement. Histograms plot proportions of velocities over 100-msec periods, head velocity in 4 deg/sec demarcations, and right eye, left eye, and vergence velocities in 1 deg/sec demarcations. Vergence velocities to the right of zero signify convergence, whereas vergence velocities to the left of zero signify divergence. (From Ref. 2)

Key Terms

Binocular viewing; image velocity; monocular vision; vergence eye movements; vestibulo-ocular reflex

General Description

When observers rotate their heads while fixating a distant target with both eyes, eye movement compensation for head rotation is neither very good nor the same in both eyes. Av-

erage retinal image speed within each eye is 0-5 deg of visual angle/sec, and the speed of changes in retinal image position between eyes is up to 3 deg/sec. Subjectively, vision remains clear.

Applications

Tasks where fixation must be maintained during active movement of observer.

Methods

Test Conditions

- Eye, head, and visual field rotations with respect to fixed-earth framework recorded by rotating magnetic field technique
- Sensor coils of fine wire embedded in annulus of silicone rubber were attached to each eye and forehead
- Noise of recording technique, expressed as standard deviation, was 2 min on eye position and dif-

ference in eye position channels and <6 min on head channel

- Observers maintained line of sight monocularly or binocularly on a distant target (airport control tower 5000 m away) from a 15th floor window while rotating head back and forth at increasing frequencies of oscillation until highest possible frequency obtained (range of oscillations 0.25-5 Hz, and from 30 deg to ~15 min)

- Task repeated while maintaining fixation on an imaginary target in the dark to assess vestibulo-ocular response
- Coil removed from forehead and attached to mirror; with head still, observers maintained binocular line of sight on target through mirror that oscillated horizontally (binocular smooth pursuit)

Experimental Procedure

- Independent variables: head position (still or active rotation), type

of target (real or imaginary), type of fixation (monocular or binocular)

- Dependent variables: retinal image motion in each eye, difference between retinal image motion in each eye (position of left eye less position of right eye) or vergence
- Observer's task: maintain line of sight at instructed target
- 4 experienced observers with normal or corrected 20/20 distance vision

Experimental Results

- Average retinal image speed is ~4 deg/sec within each eye during head rotation (compared with 20-40 min/sec when observer required to hold head still); these small motions are beneficial for the processing of visual information because they prevent perceptual fading that results from a stabilized image and yet are below the speed (~2 deg/sec) at which retinal image motion has adverse effects on contrast sensitivity.
- Observers report phenomenally clear, fused, and stable images.
- Two observers had much higher retinal image motion in dark, i.e., during fixation of imaginary target; one observer did not benefit much from visual target (about equal visual

motion in both conditions); a fourth observer compensated better with one eye in light (real target) and with other eye in dark (imaginary target).

Variability

All observers showed comparable retinal image motion in each eye and comparable vergence movements. However, each observer's pattern of eye-movement compensation varied.

Repeatability/Comparison with Other Studies

Other studies (e.g., Ref. 1) have shown that the two eyes differ in saccade size, i.e., that vergence movements can be of unequal amplitude, during fixation tasks.

Constraints

- Despite observer's reports of phenomenal clarity during head rotation, psychophysical experiments have not been performed to determine if there is a loss in acuity.

Key References

1. Krauskopf, J., Cornsweet, T. N., & Riggs, L. A. (1960). An analysis of eye movements during monocular and binocular fixation.

Journal of the Optical Society of America, 50, 572-578.

*2. Steinman, R. M., & Collewijn, H. (1980). Binocular retinal image motion during active head rotation. *Vision Research*, 20, 415-429.

Cross References

1.911 Visual fixation stability in the dark;

1.914 Monocular fixation on stationary targets;

1.916 Visual fixation on dimly illuminated targets;

7.313 Eye fixations and eye movements during display monitoring;

7.511 Search time and eye fixations: effects of symbol color, size and shape;

Handbook of perception and human performance, Ch. 10, Sect. 3.1

1.914 Monocular Fixation on Stationary Targets

Key Terms

Eye drifts; microsaccades; microtremors; square wave jerks; visual fixation

General Description

When an observer is asked to fixate a static point, several residual unintentional eye movements may occur, including microtremors, drifts, and saccades. The table summarizes the characteristics of common residual eye movements.

Applications

Situations where it is necessary to know the eye movements that may occur during a fixation task.

Constraints

• This information applies to conditions in which the observer's head is stabilized by a dental bite plate. When the head can move freely, the amplitude of eye movements during fixation increases.

Key References

1. Barlow, H. B. (1952). Eye movements during fixation. *Journal of Physiology*, *116*, 290-306.
2. Dell'Osso, L. F., Abel, L. A., & Daroff, R. B. (1977). "Inverse latent" macro square jerks and macro saccadic oscillations. *Annals of Neurology*, *2*, 57-60.
3. Ditchburn, R. W. (1980). The function of small saccades. *Vision Research*, *20*, 271-272.
4. Ditchburn, R. W., & Drysdale, A. E. (1977). The effect of retinal image movements on vision: I. Step-movements and pulse-movements. *Proceedings of the Royal Society*, *197 B*, 131-144.
5. Ditchburn, R. W., & Foley-Fisher, J. A. (1967). Assembled data on eye movements. *Optica Acta*, *14*, 113-118.
6. Ditchburn, R. W., & Ginsberg, B. L. (1953). Involuntary eye movements during fixation. *Journal of Physiology*, *119*, 1-17.

7. ten Doesschate, J. (1954). A new form of physiological nystagmus. *Ophthalmologica*, *127*, 65-73.
8. Feldon, S. E., & Laneston, J. W. (1977). Square-wave jerks: A disorder of microsaccades? *Neurology*, *27*, 278-281.
9. Haegerstrom-Portnoy, G., & Brown, B. (1979). Contrast effects on smooth-pursuit eye movement velocity. *Vision Research*, *19*, 169-174.
10. Heywood, S., & Churcher, J. (1971). Eye movements and the after-image: I. Tracking the after-image. *Vision Research*, *11*, 1163-1168.
11. King-Smith, P. E., & Riggs, L. A. (1978). Visual sensitivity to the controlled motion of a line or edge. *Vision Research*, *18*, 1509-1520.
12. Kowler, E., & Steinman, R. M. (1979). The effect of expectations on slow oculomotor

• During a short fixation period (400 msec), the retinal image may show a standard deviation of only 0.25 min arc of visual angle. That is, the displacement for 65% of the time may be less than half a foveal cone's width. (Ref. 1)

control: I. Periodic target steps. *Vision Research*, *19*, 619-632.

13. Kowler, E., & Steinman, R. M. (1979). The effect of expectations on slow oculomotor control: II. Single target displacements. *Vision Research*, *19*, 633-646.

14. Kowler, E., & Steinman, R. M. (1980). Small saccades serve no useful purpose: Reply to a letter by R. W. Ditchburn. *Vision Research*, *20*, 273-276.

15. Mack, A., Fendrich, R., & Pleune, J. (1979). Smooth pursuit eye movements: Is perceived motion necessary? *Science*, *203*, 1361-1363.

16. Mack, A., Fendrich, R., & Wong, E. (1982). Is perceived motion a stimulus for smooth pursuit? *Vision Research*, *22*, 77-88.

17. Murphy, B. J., Kowler, E., & Steinman, R. M. (1975). Slow oculomotor control in the presence of moving backgrounds. *Vision Research*, *15*, 1263-1268.

18. Pola, J., & Wyatt, H. J. (1980). Target position and velocity: The stimuli for smooth pursuit eye movements. *Vision Research*, *22*, 461-466.

19. Ratliff, F., & Riggs, L. A. (1950). Involuntary motions of the eye during monocular fixation. *Journal of Experimental Psychology*, *40*, 687-701.

20. Steinbach, M. J., & Pearce, D. G. (1972). Release of pursuit eye movements using after-images. *Vision Research*, *12*, 1307-1311.

21. Steinman, R. M., & Cunitz, R. J. (1968). Fixation of targets near the absolute foveal threshold. *Vision Research*, *8*, 277-286.

22. Steinman, R. M., Haddad, G. M., Skavenski, A. A., & Wyman, D. (1973). Miniature eye movements. *Science*, *181*, 810-819.

23. West, D. C., & Boyce, P. R. (1968). The effect of flicker on eye movements. *Vision Research*, *8*, 171-191.

Cross References

- 1.913 Visual fixation: relationship between head and eye movements;
1.916 Visual fixation on dimly illuminated targets

Table 1. Characteristics of residual eye movements during monocular fixation.

Type of Eye Movement	Amplitude	Frequency	Purpose	References
Microtremor	Average: 15 sec arc; always <1 min arc	30-100 Hz	No visual relevance because of high frequency relative to usual visual integration times	Refs. 5, 6, 17
Microsaccades	Range: 2-28 min arc; average: 5 min arc	1-2/sec	May improve visibility, since an image, stationary on the retina, soon fades	Refs. 3, 4, 10, 19
Square wave jerks, i.e., horizontal conjugate saccades that take eye away from fixation point and are corrected by foveating (center of fovea) saccade ~200 msec later	Range: 0.5-3 deg; average: 1 deg	Maximum frequency in normal subject is ~9/min	Not known	Refs. 2, 8
Visually controlled drift, or slow control	2.5 min	4 min arc/sec	Helps to maintain accurate fixation	Refs. 5, 16, 19
Anticipatory smooth movements (occur when observer expects fixation point to move)	No data	2-30 min arc/sec; if subject does not know direction of target's motion, speed is less; speed increases as time-until-target-movement-begins decreases	May improve promptness of pursuit, but no benefit for fixation of stationary target	Refs. 11, 12, 13
Drifting eye movements when the surround of the fixation point is subjected to real or illusory movement	No data	<12 min arc/sec in direction of grating; can be significantly reduced by using a larger fixation point	Not known	Refs. 14, 15, 16
Variable eye movements which result from viewing image still perceived after actual image removed (afterimage)	1-deg oscillations	0.5-1 Hz	Without visual landmarks, no feedback via change in retinal image position to inform subject that his eye has moved; highly variable eye movements result, which can have no bearing on fixation	Refs. 7, 9, 18
Drift which shifts retinal image into night-blind fovea, then peripheralizing saccade which restores visibility; dim red or white light as fixation target	42-64 min arc for drift vectors; 34-39 min arc for saccade vectors	Target disappeared every 7.3 sec (Observer 1) or 14.1 sec (Observer 2)	Drift is maladaptive; saccade restores visibility	Ref. 21

1.915 Effects of Target Characteristics on Eye Movements and Fixation

Key Terms

Maladaptive eye movements; pursuit eye movements; saccadic eye movements; saccadic latency; visual fixation

General Description

Human performance is largely independent of stimulus or target variables. Luminance (within the range of photopic illumination), size, and color have little effect on the efficiency of eye movements. The oculomotor system is not completely indifferent to target characteristics: (1) smooth pursuit without a moving target is very difficult, (2) it is dif-

ficult to maintain eye position without a visual signal, and (3) if illumination is beneath the photopic level, so that a target cannot be seen on the fovea, voluntary control is largely lost, and maladaptive eye movements result. The table summarizes the effects of several target characteristics on saccades, smooth movements, and fixations.

Constraints

• Some target characteristics for which there were no data reported may have effects on the characteristics of eye movements or fixation.

• Testing for the effects of target characteristics on eye movements is usually conducted with the head held immobile. Results might differ with a freely moving head or body.

Stimulus Parameter	Saccades	Smooth Movements	Eye Fixation	References
Wavelength (color)	No effect on latency	No effect on latency	Very small effect on mean fixation position, <3 or 4 min arc of visual angle	Refs. 1,6
Duration (target extinguished 1-300 msec after beginning of saccade)	Primary saccade that follows has normal accuracy and latency	No data reported	No data reported	Ref. 5
Contrast	Saccadic latency decreases dramatically as contrast is increased	Smooth-pursuit velocity to predictable ramp targets is independent of target contrast; eye velocity to unpredictable targets increases with increasing target contrast over a narrow range (0.3 log units)	No data reported	Ref. 4
Luminance (range for smooth movement information 0.5 log units above scotopic level to 1.85 log units above foveal threshold)	Saccadic latency decreases with increased target luminance (no data on extent of this relationship)	Smooth pursuit characteristics to predictable targets largely uninfluenced by target luminance, except its phase shows greater lag with scotopic targets	Maladaptive eye movements occur to bring dim targets back to foveal regions where they cannot be seen; above photopic levels, luminance has small effect on fixation characteristics	Refs. 7,8
Shape	No data reported	Some dissimilarity in shape between configurations in two eyes can still elicit normal horizontal vergence movements	Oculomotor system can maintain line of sight on any part of the stimulus free from the influence of stimulus shape characteristics	Refs. 6,9
Flicker	No data reported	No data reported	Stability of fixation is disrupted	Ref. 3

Key References

1. Doma, H. & Hallett, P. E. (1986). Aspects of saccadic eye movements towards or away from photopic, mesopic, or scotopic stimuli (Tech. Rep. RBCV-TR-86-11). In *Research in biological and computational vision*. Toronto: Department of Computer Science, University of Toronto.
2. Goodwin, A. W. (1973). The effect of colour on time delays in the human oculomotor system. *Vision Research*, 13, 1395-1398.
3. Haddad, G. M., & Winterson, B. J. (1975). Effect of flicker on oculomotor performance. In G. Lennerstrand & P. Bach-y-Rita (Eds.) *Basic mechanisms of ocular motility and their clinical implications* (pp. 489-496). Oxford: Pergamon.
4. Haegerstrom-Portnoy, G., & Brown, B. (1979). Contrast effects on smooth-pursuit eye movement velocity. *Vision Research*, 19, 169-174.
5. Hallett, P. E., & Lightstone, A. D. (1976). Saccadic eye movements towards stimuli triggered by prior saccades. *Vision Research*, 16, 99-106.
6. Steinman, R. M. (1976). Role of eye movements in maintaining a phenomenally clear and stable world. In R. A. Monty & J. W. Senders (Eds.), *Eye movements and psychological processes* (pp. 121-149). Hillsdale, NJ: Erlbaum.
7. Westheimer, G., & Mitchell, D. E. (1969). The sensory stimulus for disjunctive eye movements. *Vision Research*, 9, 749-755.
8. Wheelless, L. L., Cohen, G. H., & Boynton, R. M. (1967). Luminance as a parameter of the eye-movement control system. *Journal of the Optical Society of America*, 394-400.
9. Winterson, B. J., & Steinman, R. M. (1978). The effect of luminance on human smooth pursuit of perifoveal and foveal targets.

Cross References

- 1.916 Visual fixation on dimly illuminated targets;
- 1.934 Elicitation of saccades: effects of target size and proximity to fovea;

1.916 Visual Fixation on Dimly Illuminated Targets

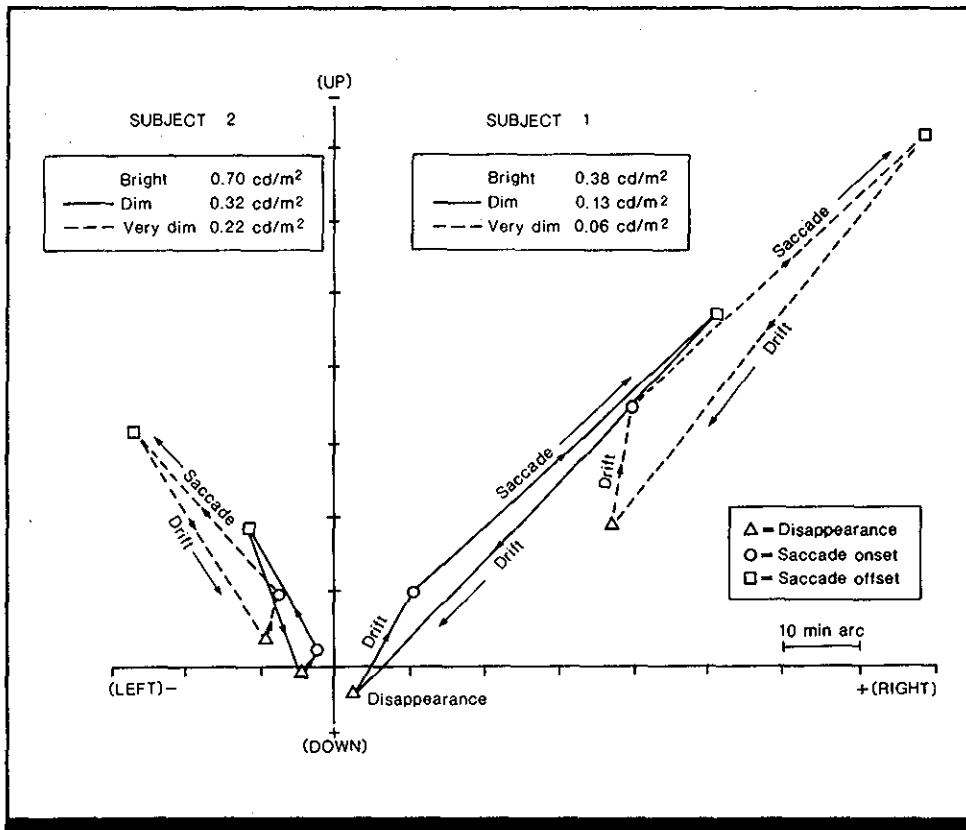

Figure 1. Disappearance cycles for 2 subjects during eccentric fixation of dim and very dim targets (bright targets not plotted). The plot represents the observer's visual field; the origin is the fixation locus for a bright stimulus. (From Ref. 4)

Key Terms

Drifts; saccadic drift; saccadic eye movements; visual fixation

General Description

When a light is too dim to be seen clearly with the foveal region of the retina, it may be seen better by fixating the light with a more eccentric (peripheral) retinal area. With dim

fixation points, regular eye movements are actually maladaptive, as they bring the light back to the fovea where it will be seen less clearly. These maladaptive eye movements do not occur with a red light of similar luminance.

Applications

Environments where dimly illuminated targets must be kept in view.

Methods

Test Conditions

- Eye position recorded by scleral contact lens method (Ref. 3) in which a mirror is attached to a stalk on a contact lens, permitting two-dimensional recording of eye position uncontaminated by head translations or torsions of eyeball

- Observers viewed 5.4 min-arc of "tungsten white" light produced by aperture in front of opal diffuser transilluminated by collimated light from a GE 1183 bulb operated at 5.0 amperes
- Neutral density filters inserted in stimulus path to alter target luminance; room dark except for light from fixation point
- Target luminances chosen separately for each observer (see Fig. 1 for values)

- Each low-luminance-target trial lasted 45 sec, preceded and followed by a 10-sec trial with bright target; order of trials with each low-luminance target alternated

Experimental Procedure

- Independent variables: target luminance, target color
- Dependent variables: eye position at moment of target disappearance, at onset of first saccade following target disappearance (following any unintentional movement), and at end of target-finding saccade

- Observer's task: indicate by an infrared strobe flash when target disappears; make a target-finding saccade
- 2 experienced observers

Experimental Results

- For both observers, the mean disappearance position of the dim target is < 10 min arc of visual angle away from the bright locus (the preferred central foveal fixation locus determined in previous tests).
- Cycles for dim target's disappearance are almost twice as long as those for very dim target's disappearance (i.e., the latter disappear more frequently), although for both targets ~50% of saccades move eye toward disappearance position.
- 76% of intersaccadic drifts with dim target, and 83% of intersaccadic drifts with very dim target move eye toward disappearance position.
- As target luminance is reduced, tendency to move eye toward disappearance position, either by drift or by saccade, increases; however, drifts play a major role in returning target to disappearance position.

- Intersaccadic drifts toward disappearance position are relatively more frequent and longer than the average saccade in either direction.
- Observers can look away from a bright target and maintain eye position fairly well, i.e., without making reflexive eye movements to bring target toward bright locus.
- Using red lights matched in brightness to the dim and very dim white lights, the target disappearance positions are scattered over a large region within fovea and near its periphery; there is no tendency to bring the target back to the portion of the central fovea preferred when bright red light is fixated; decreases in red target's visibility cause an increase in the variability of eye movements.

Variability

The pattern of results was consistent for the 2 subjects.

Repeatability/Comparison with Other Studies

An early study (Ref. 2), reported also in Ref. 4, yielded similar results.

Constraints

- Other variables, such as stimulus size or contrast, may affect eccentric fixation.
- Only 2 observers were studied.

Key References

1. Ditchburn, R. W. (1981). Small involuntary eye movements: Solved and unsolved problems. In D. F. Fisher, R. A. Monty, & J. W. Senders (Eds.), *Eye move-*

ments: Cognition and visual perception (pp. 227-235). Hillsdale, NJ: Erlbaum.

2. Simon, R. (1904). Über fixation in Dämmerungssehen. *Zeitschrift*

für Psychologie Physiologische Sinnesorgan., 36, 181-189.

3. Steinman, R. M. (1965). Effect of target size, luminance, and color on monocular fixation. *Journal of*

the Optical Society of America, 55, 1158-1165.

*4. Steinman, R. M., & Cunitz, R. J. (1968). Fixation of targets near the absolute foveal threshold. *Vision Research*, 8, 277-286.

Cross References

1.934 Elicitation of saccades: effects of target size and proximity to fovea;

1.936 Timing and accuracy of saccades to briefly lit targets;

1.937 Voluntary control of saccadic eye movements;

7.313 Eye fixations and eye movements during display monitoring;

Handbook of perception and human performance, Ch. 10, Sect. 3.1

1.917 Factors Affecting the Vestibulo-Ocular Reflex

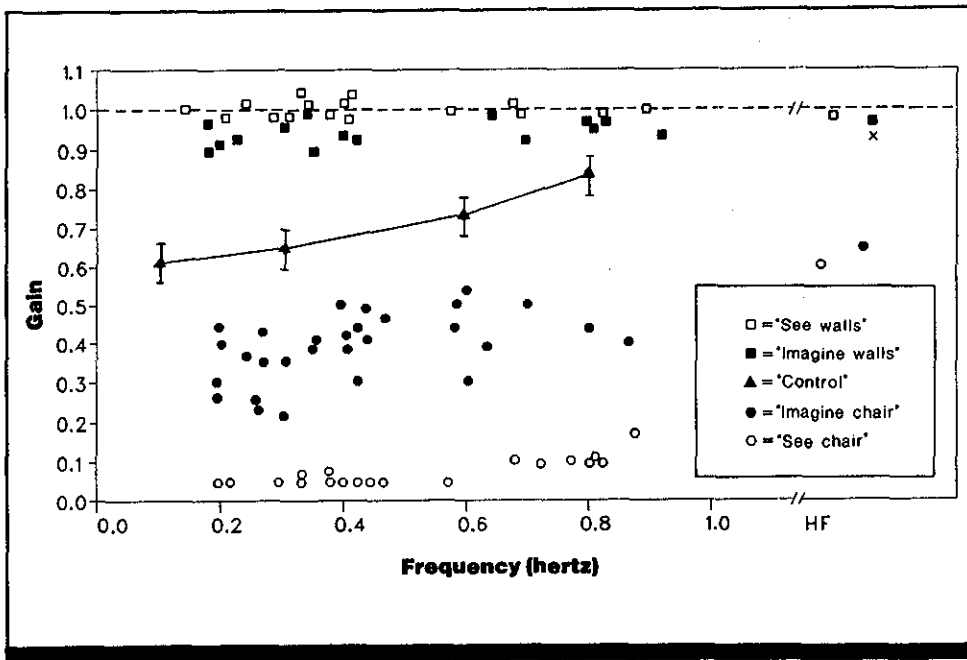

Figure 1. Gain (the ratio of slow-phase eye velocity to head velocity) as a function of the frequency of the sinusoidal motion of the subject's body (which was rotated by turning the subject's chair). "See" conditions used target lights; control (mental arithmetic task) and "imagine" conditions were done in the dark. "Chair" conditions used real or imaged light attached to subject's chair. HF indicates a single, transient, high-velocity rotation. (From Ref. 1)

Key Terms

Compensatory eye movements; electro-oculography; eye-head coordination; head rotation; instructions; retinal image stabilization; vertigo; vestibulo-ocular reflex; visual fixation

General Description

In the vestibulo-ocular reflex (VOR), head rotation in one direction is countered by eye movements in the opposite direction. The VOR serves to stabilize visual images on the retina during rotations of the head or body so that objects in the visual field remain clear. The ratio of peak compensatory eye velocity to head rotation velocity is called the gain of the VOR. A gain of 1.0 suggests a stable retinal image

since eye movement would perfectly compensate for head movement; a gain of 0.0 suggests an absence of compensation, with the eyes maintaining a fixed position relative to the head. The VOR is often measured using electro-oculographic techniques to record eye position (CRef. 1.904). The table summarizes the effects of several factors on the VOR.

Factor	Effect on VOR	References
Task	With attention to visual task precluded by rotation in dark while performing mental arithmetic, gain ranges from 0.65-0.83 (for 0.3-0.8 Hz), and is 0.97 for high-frequency (HF on Fig. 1) transient movements Gain is ~1.0 when observer fixates on stationary target (a light) and falls only slightly when imagining a stationary target Gain with fixation on visible moving target (a light) attached to observer's rotating chair is lower than with imaginary moving target (~0.1 versus ~0.4)	Ref. 1
Rotational velocity	Compensation is poorer at high angular head velocities (> 350 deg/sec)	Ref. 3
Extent of head movement	Gain increases with increasing amplitude of head rotation; small head movements are compensated relatively poorly in the dark	Ref. 4
Type of motion	At low frequencies (<3 Hz), compensation is better if motion is predictable	Ref. 2

Constraints

- Interactions among the various factors may affect the VOR, but such interactions have not been studied. The results may be valid only for the VOR in darkness.

Key References

1. Barr, C. C., Schultheis, L. W., & Robinson, D.A. (1976). Voluntary, non-visual control of the human vestibulo-ocular reflex. *Acta Otolaryngologica*, 81, 365-375.

2. Hyden, D., Ista, Y. E., & Schwarz, D. W. F. (1982). Human visuo-vestibular interaction as a basis for quantitative clinical diagnostics. *Acta Otolaryngologica*, 94, 53-60.

3. Pulaski, P. D., Zee, D. S., & Robinson, D. A. (1981). The be-

havior of the vestibulo-ocular reflex at high velocities of head rotation. *Brain Research*, 222, 159-165.

4. Skavenski, A.A., Hansen, R. M., Steinman, R. M., & Winterston, B. J. (1979). Quality of ret-

inal image stabilization during small natural and artificial body rotations in man. *Vision Research*, 19, 675-683.

5. Wilson, V. J., & Melvill Jones, G. (1979). *Mammalian vestibular physiology*. New York: Plenum Press.

Cross References

1.904 Methods of measuring eye movements;

1.918 Factors influencing visual suppression of vestibular nystagmus;

1.919 Visual suppression of vestibular nystagmus: effect of direction of head inclination;

1.958 Eye movements induced by head and body movements;

1.959 Eye torsion in response to lateral head tilt

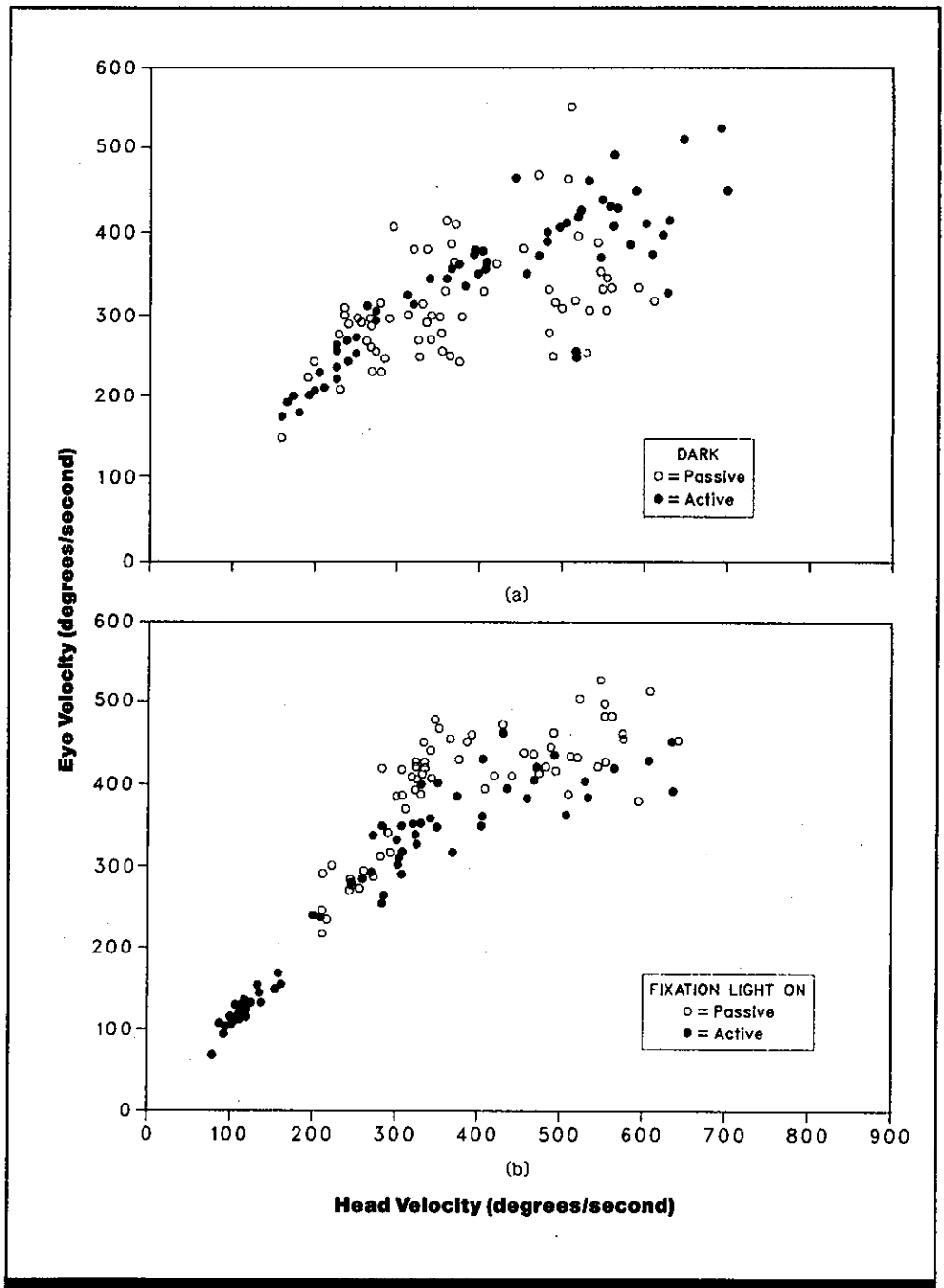

Figure 2. Eye velocity as a function of head velocity for (a) in the dark and (b) with fixation light. Eye velocity perfectly compensates for head movement when the two velocities are equal (a gain of 1.0). "Passive" indicates whole body rotation, and "active" indicates head movements only. (From Ref. 3)

1.918 Factors Influencing Visual Suppression of Vestibular Nystagmus

Key Terms

Helmet-mounted displays; intermittent illumination; optokinetic nystagmus; pursuit eye movements; target acquisition; vestibular function; vestibular nystagmus; visual fixation; visually coupled systems

General Description

When the observer or the visual scene is rotated, stability of the retinal image is maintained by a compensatory combination of vestibular and optokinetic nystagmus and voluntary visual pursuit. The vestibular nystagmus occurs around an axis parallel to the axis of head rotation, and in a normal visual environment the vestibular nystagmus is congruent in magnitude and direction with optokinetic nystagmus induced by the moving image of the stationary scene. When the observer fixates on a target that rotates with the head,

however, vestibular nystagmus is in conflict with optokinetic nystagmus and with visual-pursuit eye movements normally produced to maintain a stable target image on the fovea. When this occurs, visual suppression of some or all of the vestibular nystagmus resolves the conflict. The table lists some of the factors that influence the degree of suppression of vestibular nystagmus, indicates the effect of the factor, and cites sources of additional information.

Applications

Visual fixation of a helmet display that rotates with the head, or of cockpit displays that rotate with the body, may be degraded if visual suppression of vestibular nystagmus is reduced or absent.

Constraints

- Interactions may occur between the factors affecting the visual suppression of vestibular nystagmus.

Key References

1. Barnes, G. R. (1982). Effects of retinal location and strobe rate of head-fixed visual targets on suppression of vestibular nystagmus. In A. Roucoux (Ed.), *Physiological and pathological aspects of eye movements*. The Hague, Netherlands: W. S. Junk.
2. Barnes, G. R., Benson, A. J., & Prior, A. R. J. (1974). Visual suppression of inappropriate eye movements induced by vestibular stimulation. In H. G. J. M. Kuypers (Ed.), *Workshop meeting of European Brain and Behavior Society, Pavia: Vestibular functions and behavior*. Amsterdam: Elsevier.
3. Barnes, G. R., Benson, A. J., & Prior, A. R. J. (1978). Visual-vestibular interaction in the control of eye movement. *Aviation Space and Environmental Medicine*, 49, 557-564.
4. Barnes, G. R., & Edge, A. (1983). The effects of strobe rate of head-fixed visual targets on suppression of vestibular nystagmus. *Experimental Brain Research*, 50, 228-236.
- *5. Benson, A. J., & Barnes, G. R. (1978). Vision during angular oscillation: The dynamic interaction of visual and vestibular mechanisms. *Aviation, Space and Environmental Medicine*, 49, 340-345.
6. Benson, A. J., & Guedry, F. E. (1971). Comparison of tracking-task performance and nystagmus during sinusoidal oscillation in yaw and pitch. *Aerospace Medicine*, 42, 593-601.
7. Cohen, B., Henn, V., Raphan, T., & Dennett, D. (1981). Velocity storage, nystagmus, and visual-vestibular interactions in humans. In B. Cohen (Ed.) *Vestibular & oculomotor physiology: International meeting of the Barany Society*, Vol. 374 (pp. 421-433). New York: New York Academy of Sciences.
8. Guedry, F. E., Lentz, J. M., Jell, R. M., & Normal, J. W. (1981). Visual-vestibular interactions: The directional component of visual background movement. *Aviation, Space and Environmental Medicine*, 52, 304-309.
9. Jell, R. M., Guedry, F. E., & Hixson, W. C. (1982). The vestibulo-ocular reflex in man during voluntary head oscillation under three visual conditions. *Aviation, Space and Environmental Medicine*, 53, 541-548.
10. Ornitz, E. M., Brown, M. B., Mason, A., & Putnam, N. H. (1974). The effect of visual input on post-rotary nystagmus in normal children. *Acta Otolaryngologica*, 77, 418-425.
11. Wilson, V. J., & Melvill Jones, G. (1979). *The vestibulo-ocular system*. In V. J. Wilson & G. Melvill Jones, *Mammalian vestibular physiology*. New York: Plenum Press.

Factor	Effect on Visual Suppression of Vestibular Nystagmus	References
Frequency of sinusoidal (rotational) oscillation of head	At low frequencies (0.5 Hz) in the yaw plane , the suppression of vestibular nystagmus is nearly complete. At higher frequencies (2 Hz) there is almost no suppression	Refs. 2, 5; CRefs. 1.921, 1.926, 1.928
Plane and direction of head oscillation	Suppression of vestibular nystagmus in the pitch plane is less in the pitch forward direction than in either the pitch-backward direction or the yaw plane of oscillation	Ref. 3; CRefs. 1.959, 5.803
Foveal versus peripheral presentation of the target image	Presentation of the target image in the periphery rather than the fovea of the retina lessens the suppression of vestibular nystagmus	Ref. 1
Intermittent versus continuous illumination	Intermittent illumination of the visual target decreases the degree of suppression of vestibular nystagmus when compared to the degree of suppression during continuous illumination	Refs. 1, 4
Time constant of primary vestibular input	The duration of the postrotary nystagmus with visual fixation is limited by the time constant of the primary vestibular input (7-8 sec in humans)	Refs. 7, 10, 11
Peripheral background movement	Visual suppression of nystagmus is more effective when the relative movement of the peripheral background is appropriate to the vestibular stimulus than when it is inappropriate	Ref. 9
Voluntary head oscillations in the yaw plane	When the observer tries to match frequencies ≤ 0.5 Hz, visual suppression is evident, and there is a loss of suppression at frequencies ≥ 1.0 Hz In the dark there is no suppression at any frequency	Ref. 8; CRef. 1.917

Cross References

1.917 Factors affecting the vestibulo-ocular reflex;
1.919 Visual suppression of vestibular nystagmus: effect of direction of head inclination;

1.920 Visual suppression of vestibular nystagmus: effect of fixation;
1.921 Vestibulo-ocular nystagmus during and after aircraft spin;

1.926 Factors affecting gain of vestibulo-ocular reflex;
1.928 Gain of vestibular nystagmus: effect of object distance;
1.959 Eye torsion in response to lateral head tilt;

5.803 Perceived displacement of the horizon with head tilt and visual display rotation;
10.420 Perception of information on helmet-mounted displays during vibration

1.919 Visual Suppression of Vestibular Nystagmus: Effect of Direction of Head Inclination

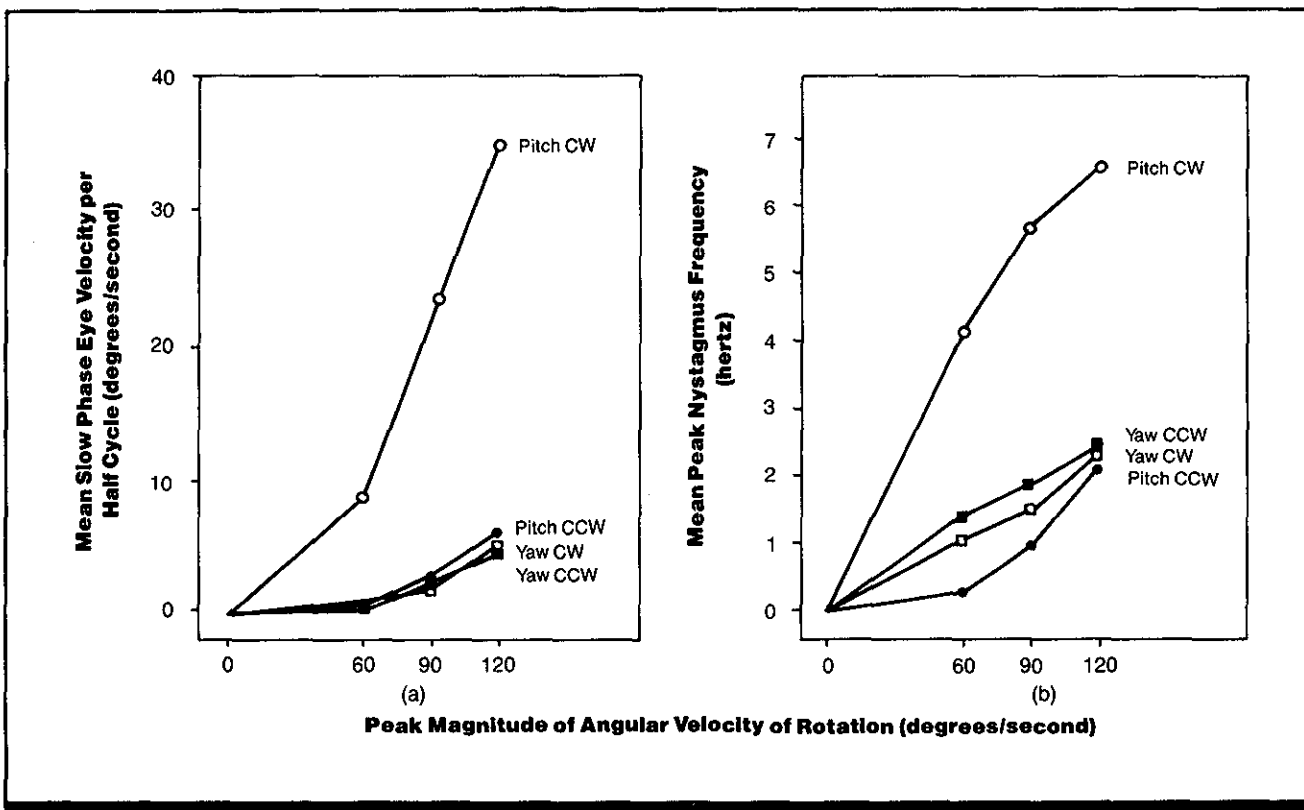

Figure 1. Nystagmus as a function of peak magnitude of angular velocity of sinusoidal rotation during angular motion of the observer in terms of (a) magnitude of mean slow-phase eye velocity and (b) mean peak frequency. CW and CCW indicate forward and backward directions, respectively, for pitch (head inclination) and clockwise and counterclockwise, respectively, for yaw (head rotation). (From Ref. 1)

Key Terms

Eye-head coordination; head rotation; nystagmus; retinal image stabilization; vestibular nystagmus; vestibulo-ocular reflex

General Description

Vestibular nystagmus produced during rotation about a vertical axis through the head by inclining the head forward (forward or clockwise pitch) is less effectively suppressed by visual stimulation than nystagmus produced by either in-

clining the head backward or rotating the head (clockwise or counterclockwise yaw). Incomplete suppression of nystagmus can produce impairment of vision that reduces performance on visual tasks.

Applications

When visual performance is degraded by vestibular reflexes brought about by rotations in different planes, the pilot of an aerospace vehicle may experience difficulties in reading displays.

Methods

Test Conditions

- Observer and instrument display rotated 90 deg about axis through head; sinusoidal rotations of 0.04 Hz about either yaw or pitch axes of head; rotation axes always Earth vertical, so that in some orientations observer lying on side; peak angular velocity magnitudes of ± 60 , ± 90 , or ± 120 deg/sec
- Stimulus for tracking task was vertical needle of cross-pointer of instrument landing system (ILS); luminance 0.34 cd/m²; needle in its null position was always parallel to rotation axes; quasi-random signal deflected needle
- Eye movements recorded both during tracking task and in darkness

Experimental Procedure

- Electro-oculographic recording of eye movements during compensatory tracking task
- Independent variables: magnitude of peak angular velocity of rotation, orientation of axis rotation, direction of angular rotation
- Dependent variables: error in tracking task performance (averaged over 5 cycles), nystagmus slow-phase velocity (averaged over 5 cycles), nystagmus frequency (measured over a 3-sec interval at peak magnitude of eye velocity)
- Observer's task: maintain needle of cross-pointer in null position by moving joystick
- 6 young male observers who did not suffer from motion sickness

Experimental Results

- Vertical nystagmus has a greater amplitude and frequency during forward tilt than during either backward tilt (pitching) or rotation (yawing) in either direction ($p = 0.01$) (Fig. 1).
- The ratios of vestibular nystagmus in pitch-forward to pitch-backward direction are 13.8, 7.6, and 5.6 at peak angular velocity magnitudes of 60, 90, and 120 deg/sec, respectively.
- When the observer is rotated sinusoidally with visual input from a tracking task, slow-phase velocity and peak frequency of nystagmus increase with peak angular velocity of rotation.
- There is a strong positive correlation between error score on the tracking task and magnitude of peak angular velocity of rotation. Error scores for pitch-forward rotation were sig-

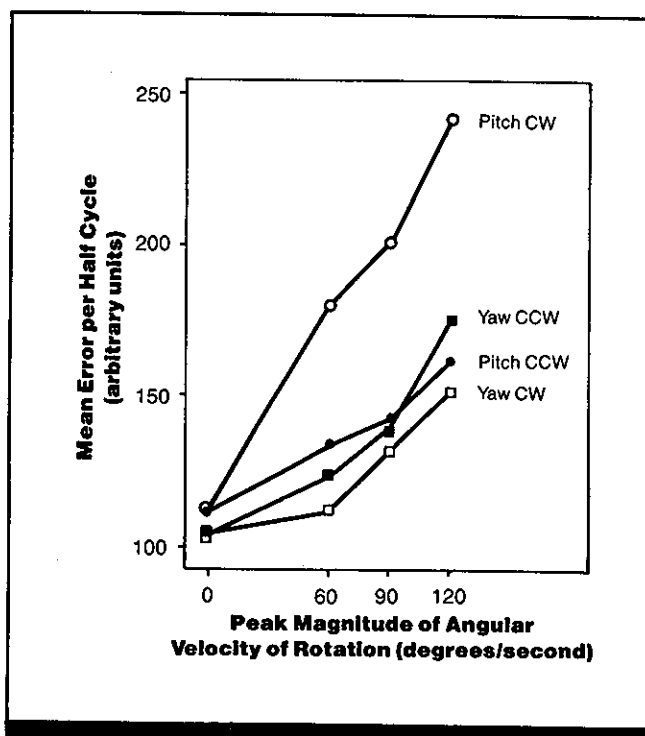

Figure 2. Tracking-task error as a function of peak magnitude of angular velocity of rotation for different axes and directions of rotation. CW and CCW as for Fig. 1. (From Ref. 1)

nificantly greater ($p = 0.01$) than scores for other rotations and directions (Fig. 2).

Variability

Analysis of variance of mean eye-velocity scores was used to test significance.

Constraints

- A number of other factors (such as voluntary head oscillation, background illumination, target illumination, etc.) are also known to influence visual suppression of vestibular nystagmus and should be taken into account when apply-

ing these results under different conditions (Ref. 2; CRef. 1.920).

- Results may vary for non-Earth vertical orientations for other magnitudes of angular velocity of rotation, and for other oscillation frequencies.

Key References

*1. Benson, A. J., & Guedry, F. E. (1971). Comparison of tracking-task performance and nystagmus during sinusoidal oscillation in yaw and pitch. *Aerospace Medicine*, 42, 593-601.

2. Jell, R. M., Guedry, F. E., & Carroll, H. (1982). The vestibulo-ocular reflex in man during voluntary head oscillation under three visual conditions. *Aviation, Space, and Environmental Medicine*, 53, 541-548.

3. Matsuo, V., Cohen, B., Raphen, T., de Jong, V., & Henn, V. (1979). Asymmetric velocity storage for upward and downward nystagmus. *Brain Research*, 176, 159-164.

Cross References

1.917 Factors affecting the vestibulo-ocular reflex;

1.920 Visual suppression of vestibular nystagmus: effect of fixation;

1.959 Eye torsion in response to lateral head tilt;

1.960 Factors affecting coordination of head rotation and eye movements;

5.803 Perceived displacement of the horizon with head tilt and visual display rotation

1.920 Visual Suppression of Vestibular Nystagmus: Effect of Fixation

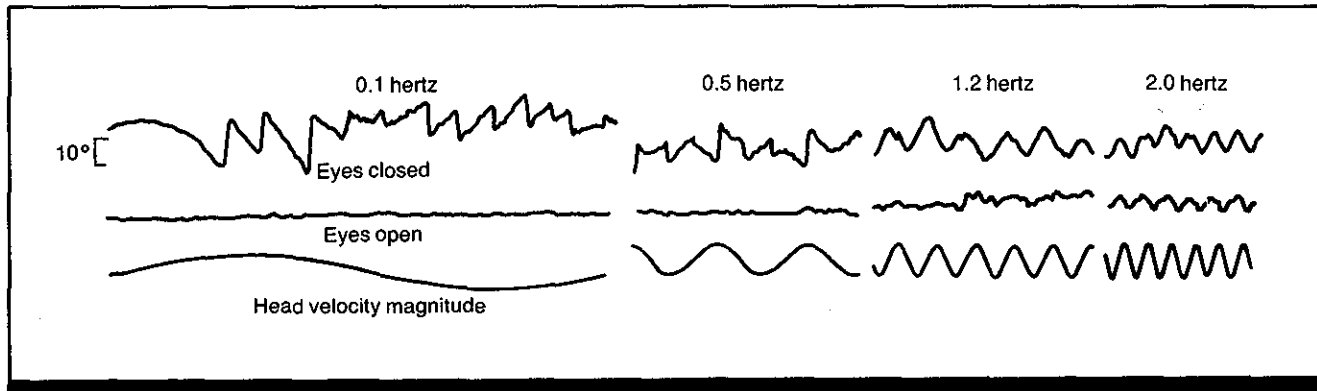

Figure 1. Eye movement with head oscillation about the yaw-axis (sinusoidal head rotation) with the eyes closed or with the eyes open while attempting to read a head-fixed display. Magnitude of head velocity is shown for comparison. (From Ref. 1)

Key Terms

Digital displays; electro-oculography; eye-head coordination; head rotation; helmet-mounted displays; nystagmus; retinal image stabilization; vestibular nystagmus; vestibulo-ocular reflex; visual fixation; visual-vestibular interaction

General Description

Vestibular nystagmus produced by sinusoidal head rotation about a vertical axis is suppressed by visual fixation on an object rotating with the head up to a frequency of 1.0 Hz. Beyond 1.0 Hz, the amplitude of nystagmus increases until,

at a frequency of 2 Hz, its amplitude is almost as great as with eyes closed. Incomplete suppression of nystagmus leads to impairment of vision and reduced performance on visual tasks such as reading digital displays.

Applications

Reading helmet-mounted digital displays is impaired at high frequencies of head rotation.

Methods

Test Conditions

- Observer rotated about earth-vertical yaw-axis of body; head immobilized with respect to body; sinusoidal rotations with randomized frequencies of 0.2-2 Hz; peak

angular velocity ± 40 deg/sec

- Row of three randomized digits flanked by checker board-pattern visual display; luminance 85 cd/m^2 for digits and 0.7 cd/m^2 for background; each digit subtended 12×7 min arc of visual angle at the eye

Experimental Procedure

- Electro-oculographic recording while reading numerical display
- Independent variable: frequency of angular oscillation
- Dependent variables: lateral eye movements, number of digits read, number of reading errors made
- 20 measurements of magnitude of slow-phase velocity were made

at each frequency of oscillation for 10 consecutive cycles at the two peaks of stimulation

- Observer's task: close eyes for 30-60 sec and perform simple arithmetic; open eyes and read digits quickly and accurately
- 5 male and 3 female observers with normal eyesight and no known neuro-otological defects

Experimental Results

- When the observer is rotated sinusoidally while attempting to read, slow-phase nystagmus first occurs at rotational frequencies >1 Hz ($p = 0.01$).
- The slow-phase velocity of vestibular nystagmus increases rapidly until it is only 20% less at 2 Hz than that obtained with the eyes closed.
- The suppression of the vestibular nystagmus, as a ratio of the magnitudes of the slow-phase velocity in the "eyes open" and "eyes closed" conditions, is fairly adequate at frequencies up to 1.0 Hz, but at higher frequencies suppression rapidly declines in effectiveness.

- Concomitantly, an observer experiences little difficulty reading the display at frequencies of 0.1 and 0.2 Hz; as the frequency of oscillation increases, there is a progressive deterioration, and at the higher frequencies there is a marked decrement in reading performance.

Variability

Standard deviations are shown in Fig. 2.

Repeatability/Comparison with Other Studies

Results are similar to those reported by other studies.

Constraints

- Relative movement between head and display was <1 min arc of visual angle at frequencies of <8 Hz.
- Results may vary for pitch and roll axes of rotation, for non-vertical axes of rotation, or for peak angular velocities different from those employed here.
- A number of other factors (such as peripheral background movement, voluntary head oscillation, etc.) are also known to influence visual suppression of vestibular nystagmus, and should be taken into account when applying these results under different conditions (Refs. 2, 3, 4, 5; CRef. 1.918).

Key References

- *1. Barnes, G. R., Benson, A. J., & Prior, A. R. J. (1978). Visual-vestibular interaction in the control of eye movement. *Aviation, Space, and Environmental Medicine*, 49, 557-564.
2. Gauthier, G. M., Piron, J.-P., Roll, J.-P., Marchetti, E., & Martin, B. (1984). High-frequency vestibulo-ocular reflex activation through forced head rotation in man. *Aviation, Space, and Environmental Medicine*, 55, 1-7.
3. Guedry, F. E., Lentz, J. M., Jell, R. M., & Norman, J. W. (1981). Visual-vestibular interac-

tions: The directional component of visual background movement. *Aviation, Space, and Environmental Medicine*, 52, 304-309.

4. Jell, R. M., Guedry, F. E., & Hixson, W. C. (1982). The vestibulo-ocular reflex in man during voluntary head oscillation under these visual conditions. *Aviation, Space, and Environmental Medicine*, 53, 541-548.

5. Wells, M. J., & Griffin, M. J. (1984). Benefits of helmet-mounted display image stabilization under whole-body vibration. *Aviation, Space, and Environmental Medicine*, 1, 13-18.

Cross References

- 1.918 Factors influencing visual suppression of vestibular nystagmus;
- 1.919 Visual suppression of vestibular nystagmus: effect of direction of head inclination;
- 1.960 Factors affecting coordination of head rotation and eye movements;
- 10.409 Factors affecting human performance during vibration;
- 10.420 Perception of information on helmet-mounted displays during vibration

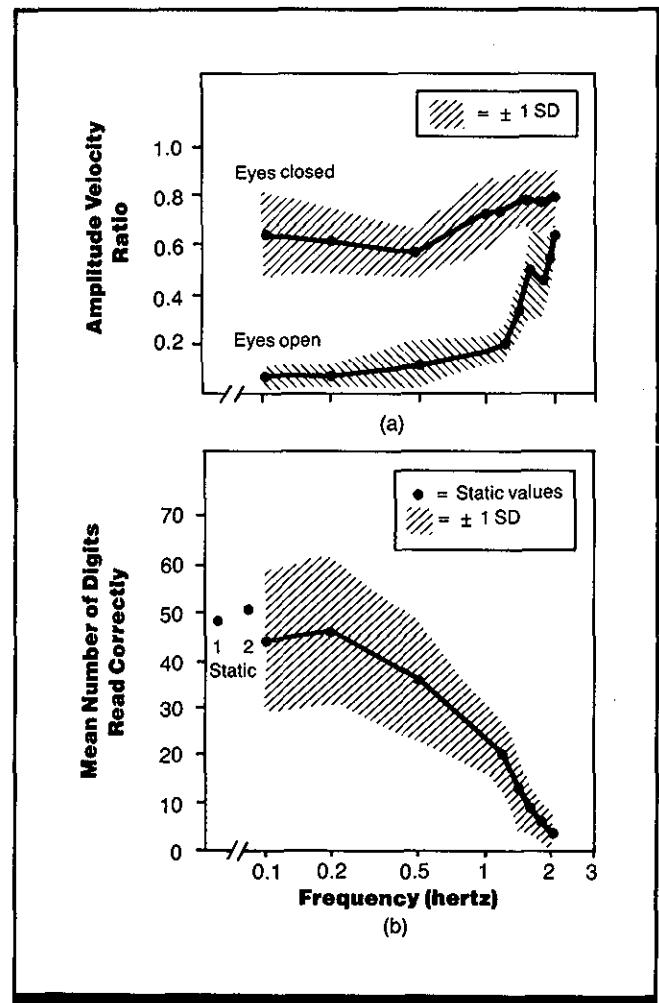

Figure 2. (a) Comparison of the amplitude ratio of slow-phase-nystagmus eye velocity to head velocity during sinusoidal rotation of the head for eyes closed and for eyes open while reading a display rotating with the head. (b) Reading performance in terms of the number of digits correctly read in a 30-sec interval as a function of rotation frequency. (From Ref. 1)

1.921 Vestibulo-Ocular Nystagmus During and After Aircraft Spin

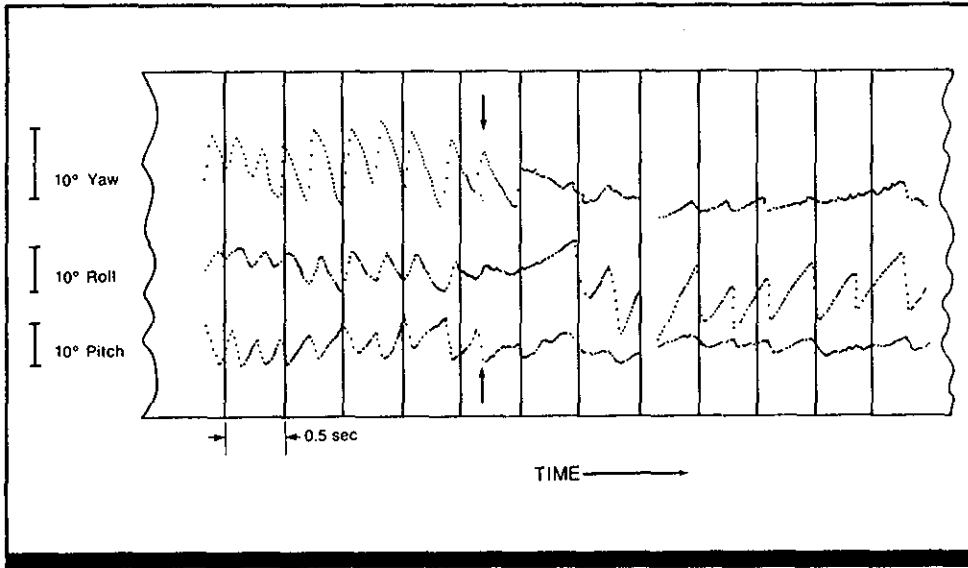

Figure 1. Vestibulo-ocular nystagmus during aircraft spin. Records show yaw, roll, and pitch of eyes relative to head for 1 observer. Spinning aircraft recovers at time indicated by arrow (From Ref. 3.)

Key Terms

Aircraft spin; compensatory eye movements; eye-head coordination; head roll; nystagmus; oculogyral illusion; optokinetic nystagmus; retinal image stabilization; semicircular canals; spatial disorientation; vertigo; visual fixation; visual-vestibular interaction

General Description

When an airplane spins, the pilot is subjected to violent pitch, roll, and yaw movements. When the plane recovers, the inertia of the semicircular canals stimulates reverse nystagmus (CRefs. 1.909, 1.917). The reverse nystagmus for

pitch and yaw are probably counteracted by an opposite optokinetic after-nystagmus (CRef. 1.917). Roll after-nystagmus is not counteracted and is substantial, and may lead the pilot to enter a new spin.

Applications

The limited capacity for visual-following in the plane of the roll may make recovering from an aerodynamic spin difficult. Multiple turn spins lasting longer than 5-10 sec are inadvisable in the early stages of training, and even experienced pilots should approach multiple-turn spinning in

stages. Director-type indication of procedures for recovery from a spin should be installed. Effects attributable to rotational stimulation in the roll plane can be minimized by keeping the head and eyes directed toward the horizon at all times during a spin.

Methods

Test Conditions

- Observer exposed to two eight-turn erect spins, one to the left and one to the right, in jet trainer aircraft; during one spin, observer looked through forward windscreen, and during the other at the instrument panel

- One record obtained while subject flying the aircraft
- Observer wore helmet containing eye-movement recording system; helmet fixed to skull by dental bite-plate; nasal oxygen mask used at high altitude
- Yaw component of aircraft angular velocity rose gradually to 50-60 deg/sec, then fell to zero; average angular pitch velocity ~0; roll angular velocity rose rapidly

- to ~150 deg/sec and then oscillated violently, with angular accelerations reaching ~200 deg/sec
- Eye movements recorded for left eye; observer viewed through right eye
- Eye movements recorded using cine-oculographic technique (16 mm motion pictures of the eyes) (CRef. 1.904)

Experimental Procedure

- Independent variable: time from onset of spin, observer looked through windscreen or at panel
- Dependent variables: roll, pitch, and yaw components of eye movements relative to the skull
- Observer's task: look outside through forward windscreen or at instrument panel, as instructed, during spin
- 5 pilots and 1 non-pilot as observers

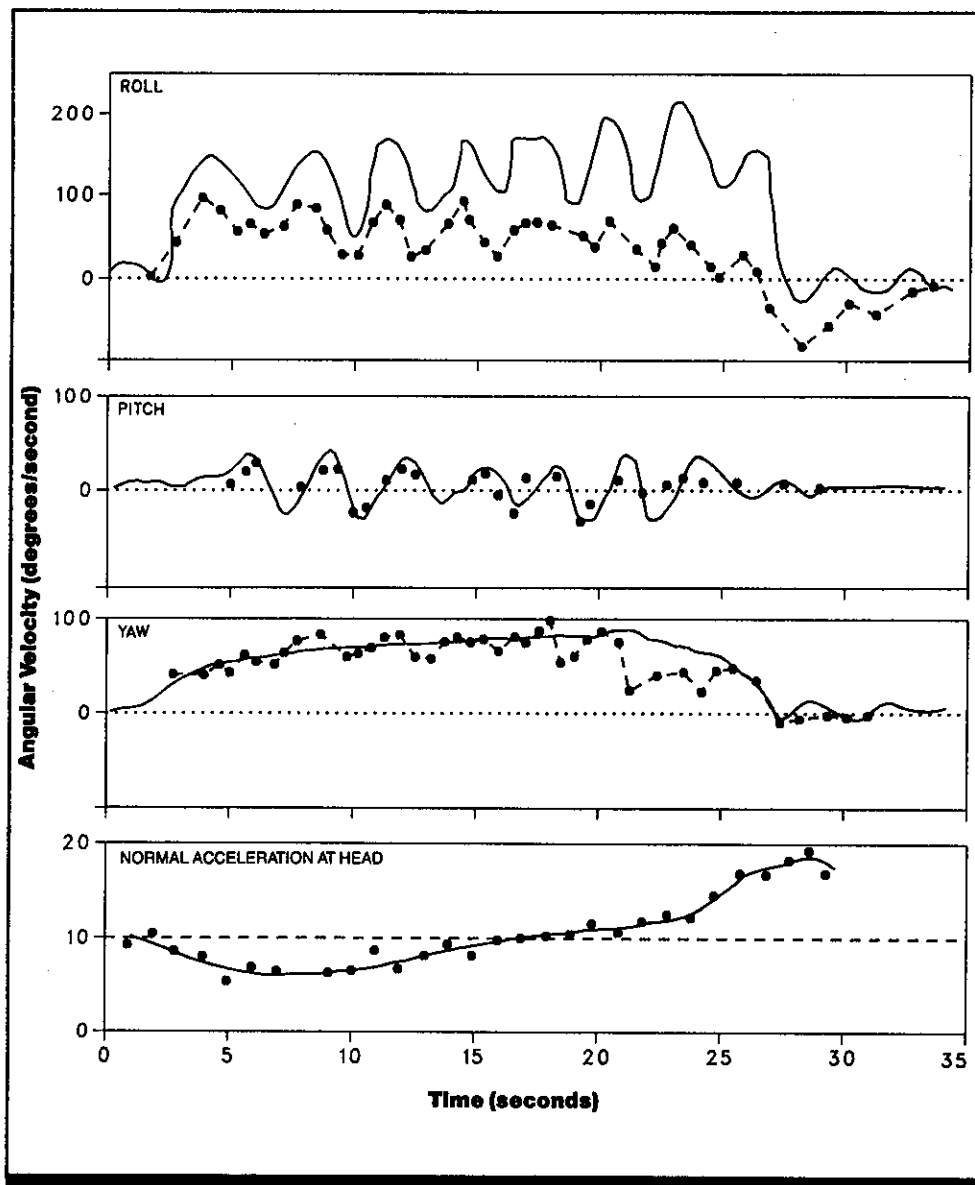

Figure 2. Vestibulo-ocular eye movements in aerodynamic spin. Pilot looking through windscreen during eight-turn spin; aircraft recovers at 27 sec. Plot shows slow-phase eye velocity from photographic measurement of roll, pitch, and yaw components referred to skull. Continuous lines show smooth eye angular velocity required to counteract aircraft angular rotation; points are observed compensatory eye movements. Yaw: intermediate level of stress (~ 70 deg/sec) is well compensated until ~ 20 sec, at which point vestibular signal wanes due to mechanical properties of canal (elastic restoration of cupula). Pitch: mild stress and good compensation along pitch axis in this example. Roll: severe stress of $100\text{--}150$ deg/sec along roll axis with compensation deteriorating with time. (From Ref. 3.)

Experimental Results

- Performance was not affected by direction of observer's view.
- Approximately correct compensatory angular eye-movement velocity in the yaw plane is maintained until ~ 20 sec after spin entry. This is followed by intermittent failure to follow, although as rotation slows, good following is restored. On recovery, only slight reverse nystagmus appears in the yaw plane, presumably because of compensatory optokinetic after-nystagmus.
- Visual-following in the pitch plane is good throughout.
- The greatest discrepancy between actual and required eye angular velocity for retinal image stabilization occurs in the roll plane. Initially, the roll component of compensatory eye angular velocity closely matches the required value for image stabilization, but thereafter there is a progressively larger discrepancy. The pilot may risk losing control during aircraft recovery because of severe post-rotatory rolling

movements. At the time of recovery of the aircraft, eye angular velocity in the roll plane reverses.

Variability

No information on variability was given.

Repeatability/Comparison with Other Studies

During rolling maneuvers that induce strong vestibular inputs, pilots tend to perceive a bending of the artificial horizon on the instrument panel (an oculogyral illusion) (Ref. 4). Another oculogyral illusion, illusory visual movement in the direction of body rotation, can be induced by rotating observers about the midbody axis (Ref. 5). When observers are asked to estimate the headcentric velocity of an object that is fixed with respect to the head, illusory movement increases during acceleration and subsides within ~ 40 sec after the observer reaches a steady velocity.

Constraints

- Data may be valid only for violent oscillations in the roll plane.
- Data may not be valid for larger or shorter duration aircraft spins and may not be valid for inverted spins.
- Data may not be valid for yaw and pitch angular velocities greater than those in this research.

Key References

1. Lentz, J. M., & Guedry, F. E. (1982). Apparent instrument horizon deflection during and immediately following rolling maneuvers.

Aviation, Space & Environmental Medicine, 53, 549-553.

2. Melvill Jones, G. (1963). Ocular nystagmus recorded simultaneously in three orthogonal planes. *Acta Otolaryngologica, 56, 619-631.*

*3. Melvill Jones, G. (1965). Vestibulo-ocular disorganization in the aerodynamic spin. *Aerospace Medicine, 36, 966-983.*

4. Melvill Jones, G., Barry, W., & Kawalski, N. (1964). Dynamics of

the semicircular canals compared in roll, pitch and yaw. *Aerospace Medicine, 35, 984-989.*

5. Parsons, R. D. (1970). Magnitude estimates of the oculogyral illusion during and following angular acceleration. *Journal of Experimental Psychology, 84, 230-238.*

Cross References

1.904 Methods of measuring eye movements;

1.909 Maladaptive eye movements; eliciting conditions;

1.917 Factors affecting the vestibulo-ocular reflex;

1.925 Optokinetic nystagmus: effect of instructions;

1.930 Vestibular nystagmus: effect of angular acceleration and deceleration;

5.503 Factors affecting illusory self-motion;

5.607 Factors affecting target localization;

5.706 Postural stability: effects of retinal image motion;

5.707 Postural stability: effects of illusory self-motion;

5.802 Illusory spatial displacements;

Handbook of perception and human performance, Ch. 10, Sec. 3.5

Notes

C

C

C

C

1.922 Vestibulo-Ocular Nystagmus: Interaction of Quick Phase Nystagmus and Saccades with Eye/Head Tracking

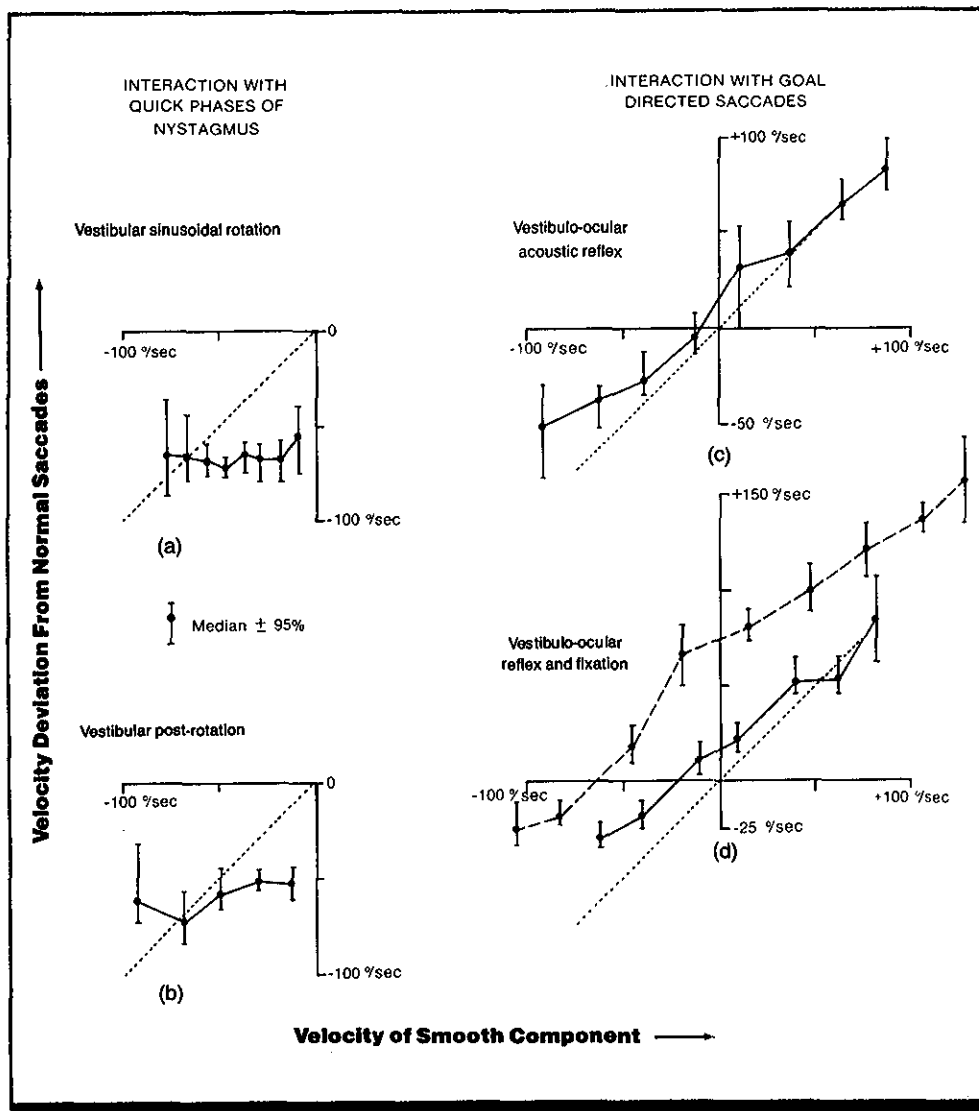

Figure 1. Interaction of quick phases and voluntary saccades with smooth eye movements (Study 1). Ordinates represent change in median saccade velocity in the dark; abscissas represent velocity of slow phase or smooth movement; both in deg/sec. The positive quadrant is for quick phases in the same direction as the smooth movement and negative quadrant is for opposite directions. The diagonal corresponds to an addition of smooth velocity and quick phase velocity. (a and b) When quick phases show a negative offset, they are uniformly slower than control saccades. A slope of zero indicates that there is no summation of velocities. (a) Quick phases of vestibular nystagmus during sinusoidal rotation in the dark. (b) Quick phases during post-rotational (reversed) vestibular nystagmus in the dark. (c and d) Voluntary saccades show two effects: the positive offset suggests that saccadic velocities are uniformly increased by smooth movement, and saccadic velocity is increased or decreased, depending on the direction of the smooth movement, by about 70% of smooth velocity. (c) Saccades to acoustic signals during *en bloc* rotation in the dark. (d) Saccades to small red light stepping within a range of 45 deg in 11-deg steps during rotations of 125 deg/sec (dashed line) or 75 deg/sec (solid line). Data in each panel are medians and 95% limits are based on 4-13 observers per panel. (From R. Jürgens, W. Becker, & P. Rieger, Different effects involved in the interaction of saccades and the vestibulo-ocular reflex, *Annals of the New York Academy of Science*, 1981, 374. Reprinted with permission.)

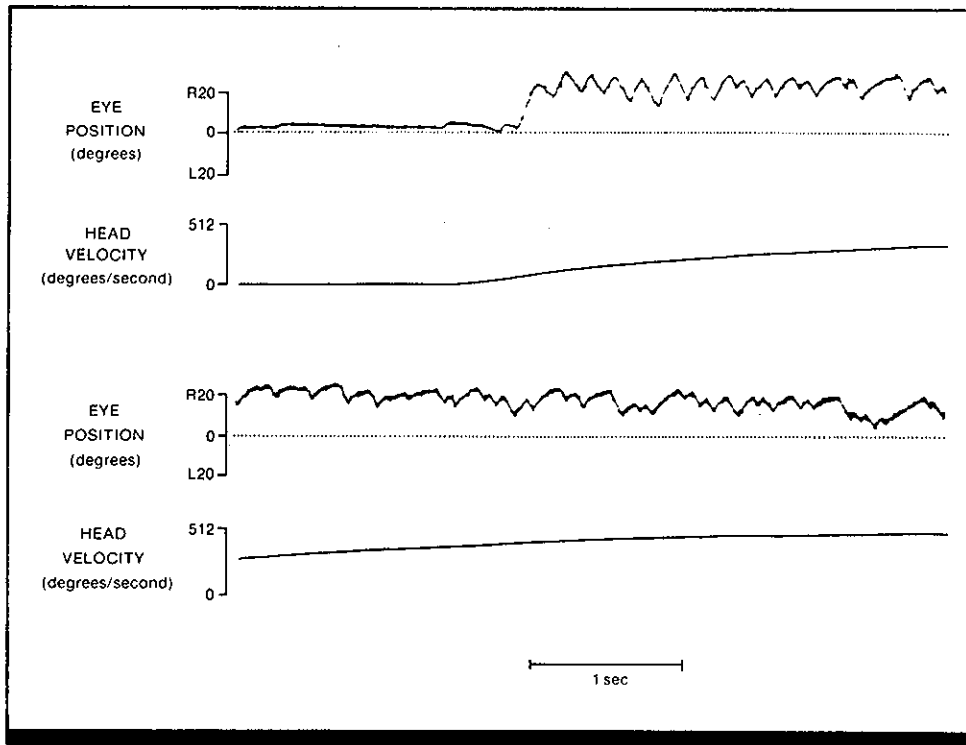

Figure 2. Vestibulo-ocular nystagmus at high head velocities (Study 2). Head and body rotated passively *en bloc* to right in darkness. Upper and lower records are continuous. (From Ref. 2)

Key Terms

Electro-oculography; eye-head coordination; head rotation; involuntary eye movements; nystagmus; quick phase nystagmus; saccadic eye movements; slow phase nystagmus; target acquisition; vestibular nystagmus; vestibulo-ocular reflex; visual fixation

General Description

Vestibular nystagmus is eye movement resulting from disturbance of the vestibular system and may be categorized as slow phase (the vestibulo-ocular response) or quick phase (quick, involuntary movements that counteract the slow-phase movements). The quick-phase movements of nystagmus are in the same direction as head rotation. When head

rotation velocity is <120 deg/sec, the quick-phase movements are 60 deg/sec slower than voluntary saccades of the same amplitude; quick-phase velocity is independent of slow-phase velocity. For head rotation velocities >200 deg/sec, the quick-phase velocity is slower than slow-phase velocity; also, the quick-phase duration is prolonged.

Applications

Situations in which a rotating observer is required to visually fixate targets.

Methods

Test Conditions

Study 1 (Ref. 1)

- Observer, with head stabilized, seated in chair that rotated sinusoidally at 1.0 Hz and 120 deg/sec peak velocity
- Two horizontal bars, one rotating with observer and one at a fixed location; each bar had five targets [red light-emitting diodes (LEDs)] separated by 11.4 deg of visual angle
- Targets turned on in random sequence

- Horizontal eye movements between two stationary targets or two rotating targets recorded electro-oculographically

Study 2 (Ref. 2)

- Dark-adapted observer rotated *en bloc* in Bärány chair accelerated to head velocities near 500 deg/sec
- Observer wore head-movement monitor
- Observer fixated stationary target (red LED) located ~ 80 cm away, then made head movements covering ~ 100 -500 deg/sec, target then

extinguished and observer asked to fixate remembered target location while continuing to make eye movements of varying peak velocities; target then re-lit and same events repeated except that observer's head not moved passively (with body stationary) at similar velocities; finally, observer rotated *en bloc* in darkness and asked to look into environment during rotation

Experimental Procedure

Study 1

- Independent variable: type of target (stationary or rotating)

- Dependent variables: eye position and velocity
- Observer's task: fixate on target
- 10 healthy observers

Study 2

- Independent variables: (a) type of rotation (active or passive head only; *en bloc*); (b) rotation velocity
- Dependent variables: duration and speed of quick and slow phases of nystagmus
- Observer's task: fixate on remembered target location or look into environment
- 3 observers, aged 27-54

Experimental Results

- Goal-directed saccades during passive *en bloc* rotation are as accurate as normal saccades with the head still (Fig. 1d).
- For head velocity of 120 deg/sec, the quick phase of nystagmus is ~60 deg/sec slower than voluntary saccades of similar amplitude.
- For head velocity of 120 deg/sec, quick-phase velocity is independent of low-phase velocity.
- For head velocity >200 deg/sec, the quick-phase slows as head velocity increases above 200 deg/sec, eventually becoming slower than slow-phase velocity, although its duration is prolonged.
- No differences are seen between active or passive rotations or between head and body rotations.
- Similar results are found for both illuminated and remembered targets.

- For peak head velocities <350 deg/sec, gain eye movements (peak eye velocity/peak head velocity) is ~1 when observer fixates on a real or imagined object.
- Maximum slow-phase velocity of the vestibulo-ocular reflex is ~500 deg/sec, and both results hold for active and passive head rotation (Ref. 2).

Variability

For Study 1, variability data are as shown in Fig. 1. In Study 2, eye velocity data become more variable at higher rotation velocities.

Repeatability/Comparison with Other Studies

Data are compatible with recent models of saccade generation.

Constraints

- Data may not be valid for more complex rotational movements.
- Data may vary depending on physiological characteristics of observer.

Key References

*1. Jürgens, R., Becker, W., & Rieger, P. (1981). Different effects involved in the interaction of sac-

cades and the vestibulo-ocular reflex. *Annals of the New York Academy of Sciences*, 374, 744-754.

*2. Pulaski, P. D., Zee, D. S., & Robinson, D. A. (1981). The behavior of the vestibulo-ocular reflex at high velocities of head rotation. *Brain Research*, 22, 159-165.

3. Zee, D. S., & Robinson, D. E. (1978). A hypothetical explanation of saccadic oscillations. *Annals of Neurology*, 5, 405-414.

Cross References

1.917 Factors affecting the vestibulo-ocular reflex;
 1.918 Factors influencing visual suppression of vestibular nystagmus;

1.919 Visual suppression of vestibular nystagmus: effect of direction of head inclination;

1.920 Visual suppression of vestibular nystagmus: effect of fixation;

1.960 Factors affecting coordination of head rotation and eye movements;

Handbook of perception and human performance, Ch. 10, Sect. 3.2

Notes

C

C

C

C

1.923 Factors Influencing Duration of Postrotary Nystagmus

Key Terms

Cupulometry; head rotation; oculomotor disturbances; post-rotary nystagmus; spatial orientation; turning illusions; vertigo; vestibular illusions; vestibulo-ocular interaction; visual fixation

General Description

When an observer's head is rotated at a constant velocity for longer than ~20 sec, **postrotary nystagmus** occurs on cessation of the rotation. This postrotary nystagmus results in inappropriate vestibulo-ocular compensation. Such inap-

propriate compensation produces oculomotor disturbances and turning illusions. The table lists some of the factors that influence the duration of postrotary nystagmus, indicates the direction and magnitude of the effect, and cites sources of additional information.

Constraints

- Interaction may occur between factors that influence the duration of postrotary nystagmus.

Factors	Direction and Magnitude of the Effect	References
Rotational axes of head	Mean time constants of the decay of the angular velocity in the slow phase of nystagmus following head rotations in the yaw, pitch, and roll planes are 15.6 (± 1.2), 6.6 (± 0.7), and 4.0 (± 0.4), respectively. Differences between the means for yaw and roll, yaw and pitch, and roll and pitch are all statistically significant. Mean time constants obtained from subjective cupulometry following rotations in yaw, pitch, and roll planes are 10.2 (± 1.8), 5.3 (± 0.7), and 6.1 (± 1.2), respectively. Differences between means for yaw and roll and for yaw and pitch are statistically significant ($p < 0.001$); means for roll and pitch are not significantly different. All values are in seconds; parentheses contain twice the standard error. No reports related to sense of rotation were found	Refs. 1,4 CRefs. 1.909, 1.921
Strength of stimulus	Using the method of subjective cupulometry, duration of postrotary nystagmus varies directly with the logarithm of magnitude of angular head velocity (in the range from 5-60 deg/sec). No corresponding information is available using oculography	Ref. 4 CRefs. 1.960, 3.210, 5.503, 5.505
Fixation of a target in the environment	Duration of postrotary nystagmus is decreased from ~30 to ~5 sec when the observer fixates a stationary target.	Refs. 5, 7 CRef. 1.913
Attention	Increased mental alertness increases the duration of nystagmus	Refs. 2, 7 CRef. 1.929
Practice	Subjective measurements of duration do not change with practice, even though nystagmus intensity is reduced	Ref. 3
Head tilt	The duration and gain of postrotary nystagmus is reduced if the observer tilts the head to the side after rotation of the body	Ref. 6

Key References

1. Buttner, U., & Waespe, W. (1981). Vestibular nerve activity in the alert monkey during vestibular and optokinetic nystagmus. *Experimental Brain Research*, *41*, 310-315.
2. Collins, W. E. (1974). Arousal and vestibular habituation. In H. H. Kornhuber (Ed.), *Handbook of sensory physiology: Vol. VII/2*.

Vestibular system Part 2. Psychophysics, applied aspects and general interpretations (pp. 361-368). Berlin: Springer-Verlag.

3. Collins, W. E. (1974). Habituation of vestibular responses with and without visual stimulation. In H. H. Kornhuber (Ed.), *Handbook of sensory physiology: Vol. VII/2. Vestibular system Part 2. Psychophysics, applied aspects and general interpretations* (pp. 369-389). Berlin: Springer-Verlag.

*4. Melvill Jones, G., Barry, W., & Kowalsky, N. (1964). Dynamics of the semi-circular canals compared in yaw, pitch and roll. *Aerospace Medicine*, *35*, 984-989.

5. Ornitz, E. M., Brown, M. B., Mason, A., & Putnam, N. H. (1974). The effect of visual input on post-rotary nystagmus in normal children. *Acta Otolaryngologica*, *77*, 418-425.

6. Schrader, V., Koenig, E., & Dichgans, J. (1985). The effect of head tilt or horizontal postrotary nystagmus I and II and the Purkinje effect. *Acta Otolaryngologica*, *100*, 98-105.

*7. Sokolovski, A. (1966). The influence of mental activity and visual fixation upon caloric-induced nystagmus in normal subjects. *Acta Otolaryngologica*, *61*, 209-220.

Cross References

- 1.909 Maladaptive eye movements: eliciting conditions;
- 1.913 Visual fixation: relationship between head and eye movements;
- 1.921 Vestibulo-ocular nystagmus during and after aircraft spin;

1.929 Vestibular nystagmus: effect of attention;

1.960 Factors affecting coordination of head rotation and eye movements;

3.210 Vestibular illusions;

5.503 Factors affecting illusory self-motion;

5.505 Oculogravic illusion

1.924 Optokinetic Nystagmus and Circularvection (Illusory Self-Motion)

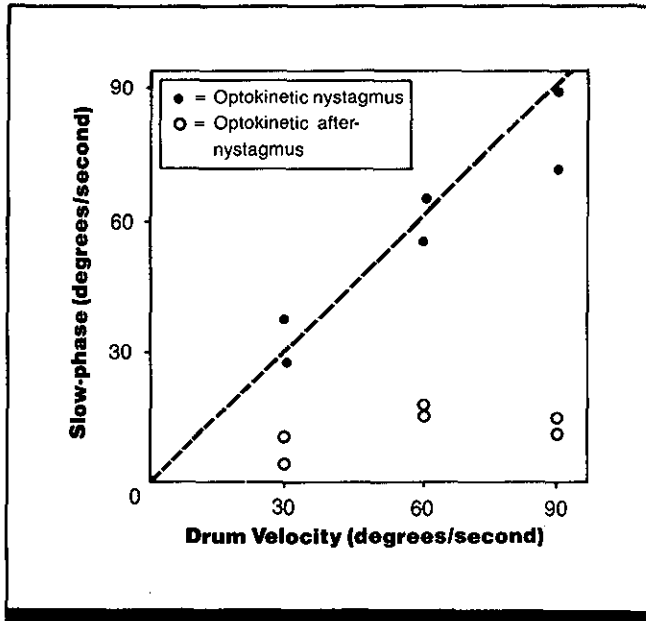

Figure 1. Slow-phase velocity of optokinetic nystagmus (●) and optokinetic after-nystagmus (○) plotted against drum velocity for 1 observer. Note that the gain of optokinetic nystagmus is close to 1, while that of optokinetic after-nystagmus is much less. (From B. Cohen, V. Henn, T. Raphan, & D. Dennett, *Velocity storage, nystagmus, and visual-vestibular interactions in humans*, *Annals of the New York Academy of Sciences*, 1981, 374. Reprinted with permission.)

Key Terms

Circularvection; moving surround; nystagmus; optokinetic nystagmus; pursuit eye movements; self-rotation; vertigo; visual fixation

General Description

When an observer is exposed to a moving surround, the eyes move reflexively so as to stabilize the image on the retina by interspersed saccadic return movements of the eyes; such a to-and-fro eye movement is termed **optokinetic nystagmus**. When suddenly exposed to a moving surround, the velocity of the pursuit movement (i.e., the slow phase) of nystagmus rises rapidly to match that of the moving surround. The time required for this matching process may be the time taken to store the velocity signal driving the slow

phase of optokinetic nystagmus. Shortly after the onset of exposure to the moving surround, **circularvection** (a sensation of self-rotation) is produced.

On turning off the light after maintained exposure to a moving surround there is a pronounced persistence of nystagmus, termed optokinetic after-nystagmus, which acts in the same direction as the preceding optokinetic nystagmus, and which declines in velocity. Such a decline may represent the discharge of activity related to slow-phase velocity stored during maintained exposure to the moving surround.

Applications

Relative movement of the visual environment with respect to the observer, such as that which occurs during aircraft spin, can produce inappropriate eye movements and vertigo.

Methods

Test Conditions

- Observer seated centrally inside earth-vertical rotating drum with internal alternating black-and-white vertical stripes, each subtending 7.5 deg arc of visual angle at rotation axis

- Drum rotated about its axis at 30, 60, or 90 deg/sec
- Observer's head was earth-vertical
- Eye movements recorded by electro-oculographic recording in light for optokinetic nystagmus and in dark for optokinetic after-nystagmus

Experimental Procedure

- Independent variables: drum velocity, duration of exposure to drum rotating at 60 deg/sec
- Dependent variables: peak angular velocity of the slow phase of nystagmus, gain of nystagmus (slow phase velocity divided by

- stimulus velocity), degree of circularvection, duration of optokinetic after-nystagmus
- Observer's task: move handle fixed to shaft of potentiometer so that each full revolution of shaft represented 360 deg of circularvection ("rotation sensation")
- 5 observers, ages 13-48

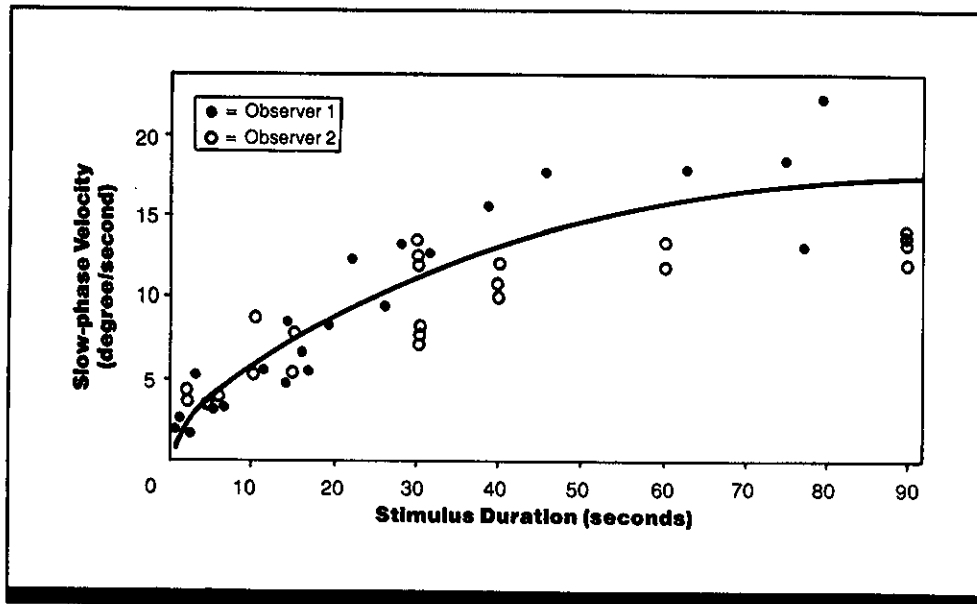

Figure 2. Velocity of optokinetic after-nystagmus in the dark plotted as a function of duration of exposure to illuminated rotating surround for 2 observers (● and ○). (From B. Cohen, V. Henn, T. Raphan, & D. Dennett, *Velocity storage, nystagmus, and visual-vestibular interactions in humans*, *Annals of the New York Academy of Sciences*, 1981, 374. Reprinted with permission.)

Experimental Results

- Onset of visual surround rotation produces horizontal optokinetic nystagmus in which eye velocity rises rapidly to maximum in first nystagmic beat.
- Gain of optokinetic nystagmus is close to 1 for drum rotations <60-90 deg/sec (Fig. 1).
- Circularvection (illusory sense of self rotation) occurs within 5-6 sec after onset of drum rotation, and persists for duration of rotation.
- Immediately after cessation of long-term exposure to rotating surround, low-amplitude optokinetic after-nystagmus begins and lasts for 45-50 sec; eye velocity magnitude is maximally 15-20 deg/sec.

- No circularvection is experienced along with optokinetic after-nystagmus.
- Increasing the duration of exposure to the rotating surround produces an increasing duration of optokinetic after-nystagmus, reaching a maximum at ~30-40 sec of exposure; time constant of rise in optokinetic after-nystagmus is ~20 sec; time constant of decay in optokinetic after-nystagmus in the dark is ~25 sec (Fig. 2).

Variability

- No information on variability was given.

Constraints

- The results, particularly the recruitment time of optokinetic nystagmus, differ considerably from those of monkeys (Ref. 3).
- Results may vary for head orientations or drum velocities different from those used in this study.

- Optokinetic nystagmus and optokinetic after-nystagmus can interact with vestibular nystagmus (Refs. 1, 2).
- Other factors may also modify the recruitment time of optokinetic nystagmus and the time constants of the rise and decay of optokinetic after-nystagmus, and should be taken into account when applying these results under different conditions.

Key References

*1. Cohen, B., Henn, V., Raphan, T., & Dennett, D. (1981). Velocity storage, nystagmus, and visual-vestibular interactions in humans. *Annals of the New York Academy of Sciences*, 374, 421-433.

2. Koenig, E., & Dichgans, J. (1981). Aftereffects of vestibular and optokinetic stimulation and their interaction. *Annals of the New York Academy of Sciences*, 374, 434-445.

3. Raphan, T., Cohen, B., & Matsuo, V. (1977). Velocity-storage

mechanism responsible for optokinetic nystagmus (OKN), optokinetic after-nystagmus (OKAN) and vestibular nystagmus. In R. Baker, & A. Berthoz (Eds.), *Control of gaze by brain stem neurons*. Amsterdam: Elsevier/North-Holland Biomedical Press.

Cross References

1.917 Factors affecting the vestibulo-ocular reflex;

1.918 Factors influencing visual suppression of vestibular nystagmus;

1.919 Visual suppression of vestibular nystagmus: effect of direction of head inclination;

1.921 Vestibulo-ocular nystagmus during and after aircraft spin;

3.210 Vestibular illusions;

5.706 Postural stability: effects of retinal image motion;

5.707 Postural stability: effects of illusory self-motion

1.925 Optokinetic Nystagmus: Effect of Instructions

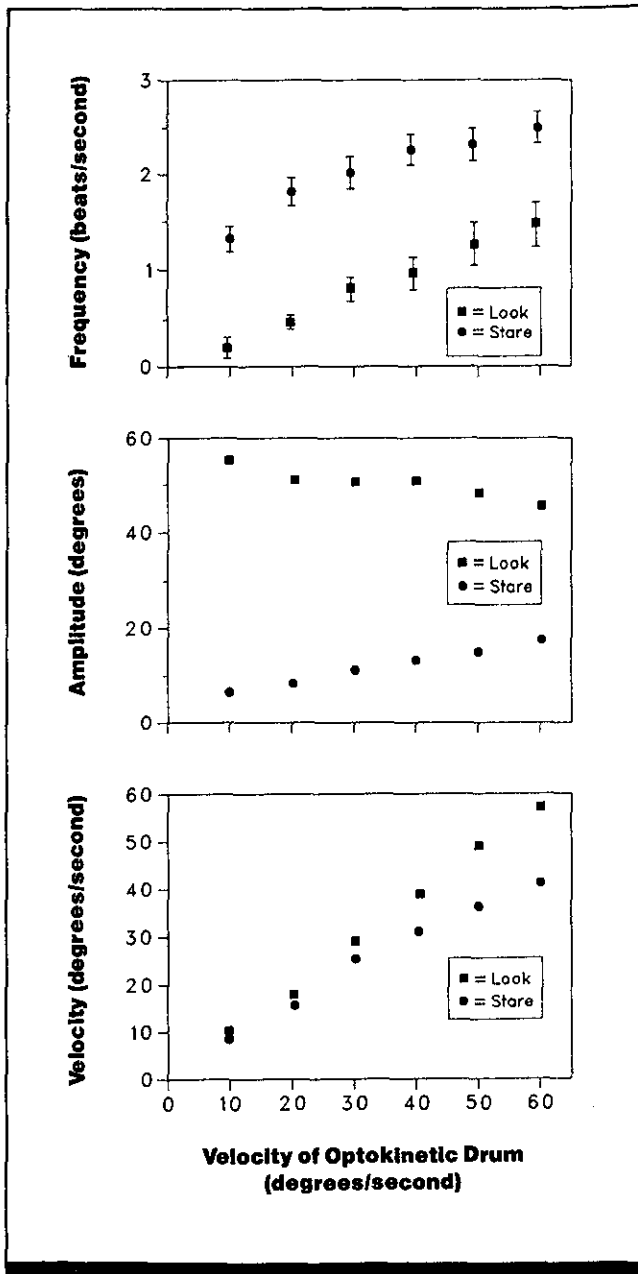

Figure 1. Optokinetic nystagmus. Frequency of the nystagmus (as fast phases/sec); mean amplitude of smooth movement between fast saccades; and velocity of smooth movement as a function of drum angular velocity. Means based on ~20 (14-33) observers. Compared with "look" nystagmus, "stare" nystagmus is of small amplitude, low velocity, and more frequently interrupted by fast saccades. (From Ref. 1)

Key Terms

Field of view; instructions; optokinetic nystagmus; target acquisition; tracking eye movements; training, visual-vestibular interaction

General Description

Observers are instructed to "look" at one stripe in a large-striped rotating drum or to "stare" straight ahead. When instructed to stare, observers' smooth movement eye velocity

is 70% of the stripe velocity, compared to 90% of the stripe velocity for the look instructions. The frequency of counter-rotating saccadic eye movements is close to the number of passing stripes.

Applications

Displays and environments requiring visual tracking of moving targets or maintenance of visual fixation in the presence of moving targets.

Methods

Test Conditions

- Observers seated at center of cylinder 1.27 m (50 in.) diameter and 1.27 m high; bottom of cylinder 0.61 m from floor; observers isolated from experimenter and recording apparatus

- Observers' eyes at center of cylinder, with head fixation achieved with chin rest
- Inside wall of cylinder consisted of 12, white, equally spaced, 1-deg vertical stripes on black background
- Diffuse illumination through white lucite top
- Optokinetic nystagmus measured by electronystagmographic methods

Experimental Procedure

- Independent variables: velocity of drum rotation, instructions (stare straight ahead or to look at a particular stripe)
- Dependent variables: frequency, amplitude, velocity of optokinetic nystagmus

- Observer's task: follow the movement of a particular stripe (look test) or gaze straight ahead (stare test)
- Observers instructed not to turn heads while drum rotated
- 33 observers, mostly students

Experimental Results

- When observers are asked to follow stripes (look test), the nystagmus is of a larger amplitude than when they stare straight ahead.
- In the look condition, the amplitude of the nystagmus remains relatively constant regardless of stimulus velocity, while in the stare condition the amplitude of the nystagmus increases with increasing stimulus velocity.
- In the look condition, the frequency of the nystagmus increases linearly with stimulus velocity, while in the stare condition the frequency nearly doubles when stimulus ve-

locity increases from 10-40 deg/sec, but changes little with further increases in stimulus velocity.

Variability

Bars in Fig. 1 represent standard deviations.

Repeatability/Comparison with Other Studies

Data are consistent with hypothesis (Ref. 2) that there are two kinds of optokinetic nystagmus. With stare instructions, reduction of stimulus area increases apparent speed of low target velocities and provides edges, modifying the optokinetic nystagmus (Ref. 3).

Constraints

- Data may be valid only for uniformly separated 1-deg stripes.
- Data may not be valid for stimulus velocities <10 or >60 deg/sec or if free head movements are permitted.

Key References

*1. Honrubia, V., Downey, W. L., Mitchell, D. P., Ward, B. A., & Ward, P. H. (1968). Experimental studies on optokinetic nystagmus. II. Normal humans. *Acta Otolaryngologica*, 65, 441-448.

2. Rademaker, G. G. J., & Ter Braak, J. W. G. (1948). On the central mechanisms of some optic reactions. *Brain*, 71, 48.

3. Schor, C., & Narayan, V. (1981). The influence of field size upon the spatial frequency response of optokinetic nystagmus. *Vision Research*, 21, 985-994.

Cross References

1.919 Visual suppression of vestibular nystagmus: effect of direction of head inclination;

1.922 Vestibular-ocular nystagmus: interaction of quick phase nystagmus and saccades with eye/head tracking;

1.923 Factors influencing duration of postrotary nystagmus;

Handbook of perception and human performance, Ch. 10, Sect. 3.3

1.926 Factors Affecting Gain of Vestibulo-Ocular Reflex

Key Terms

Compensatory eye movements; eye-head coordination; involuntary eye movements; nystagmus; optokinetic reflex; vestibular nystagmus; vestibulo-ocular reflex; visual fixation; visual stability

General Description

The gain of the vestibulo-ocular reflex (VOR) adapts when an observer is continuously exposed to a motion of the visual scene that is mismatched to the motion of the head (vestibular input); the velocity of the pursuit phase of VOR

changes so that it again matches the velocity of scene motion and thus the retinal image is stabilized. The table lists some of the factors that influence VOR gain, indicates the effect of the factor, and cites sources of additional information.

Constraints

- Interactions may occur between factors influencing magnitude and sign of gain of vestibular nystagmus.
- The gain of VOR can be modified by a long period of mental effort during rotation in the dark (Ref. 6).

Factors	Direction and Magnitude of Effect on Gain of Vestibulo-Ocular Reflex	References
Distance of object with retinal image to be stabilized for head rotations	Head rotation translates to the eyes as well as rotates them. Such translations must also be corrected for by a change in the gain of compensatory eye movements, if retinal image stabilization is to be achieved. For distant objects, the effect of the translation is small so that the required gain remains close to 1 Convergence produces an equal and opposite change of angle for the two eyes. Such equal and opposite changes are likely to cancel in their effects on vestibulo-ocular reflex (VOR) gain	CRef. 1.928
Alertness of observer	Non-alertness produces a decline of gain in the dark; alertness maintains a gain of 1 or even greater in the dark	Ref. 5 CRef. 1.929
Optokinetic nystagmus	Repeated exposure to a moving whole visual scene of vertical stripes, when the head is fixed, results in a reduction of gain as measured by rotation in the dark	Refs. 8, 9, 10
Active rotational oscillations of the head	Oscillations while observer is exposed to optical magnification requiring a 36% change in gain produces complete adaptive change after 4-20 min	Ref. 2
Axis of rotation	For the yaw- and pitch-planes, changes in gain are specific to the plane within which the visual information is distorted	Ref. 1, 7
Optical distortion of visual scene	Twofold optical magnification produces a 70% increase of gain after 4 days Optical lateral reversal of the visual scene produces a reduction of gain to 0 after 1 week, followed by a reversal of sign, and an increase in gain towards 1 after 2 weeks	Refs. 3, 4 CRef. 1.927

Key References

1. Berthoz, A., Melvill Jones, G., & Bague, A. E. (1981). Differential visual adaption of vertical canal-dependent vestibulo-ocular reflexes. *Experimental Brain Research*, *44*, 19-26.

2. Collewijn, H., Martins, A. J., & Steinman, R. M. (1983). Compensatory eye movements during active and passive head movements: Fast adaptation to changes in visual magnification. *Journal of Physiology*, *340*, 259-286.

3. Gauthier, G. M., & Robinson, D. A. (1975). Adaptation of the human vestibular-ocular reflex to magnifying lenses. *Brain Research*, *92*, 331-335.

4. Gonshor, A., & Melvill Jones, G. (1976). Extreme vestibulo-ocular adaptation induced by prolonged optical reversal of vision. *Journal of Physiology*, *256*, 381-414.

5. Johnson, D. D., & Torok, N. (1970). Habituation of nystagmus and sensations of motion after rotation. *Acta Otolaryngologica*, *69*, 206-221.

6. Melvill Jones, G., Berthoz, A., & Segal, B. (1984). Adaptive modification of the vestibulo-ocular reflex by mental effort in darkness. *Experimental Brain Research*, *56*, 149-153.

7. Melvill Jones, G., & Gonshor, A. (1982). Oculomotor response to rapid head oscillation (0.5-50 Hz) after prolonged adaptation to visual reversal. *Experimental Brain Research*, *45*, 45-58.

8. Optican, L. M., & Miles, F. A. (1985). Visually induced adaptive

changes in primate saccadic oculomotor control signals. *Journal of Neurophysiology*, *54*, 940-958.

9. Pfaltz, C. R., & Ohtsuka, Y. (1975). The influence of optokinetic training upon vestibular habituation. *Acta Otolaryngologica*, *79*, 253-258.

10. Young, L. R., & Henn, V. S. (1948). Selective habituation of vestibular nystagmus by visual stimulation. *Acta Otolaryngologica*, *77*, 159-166.

Cross References

1.917 Factors affecting the vestibulo-ocular reflex;

1.927 Vestibulo-ocular reflex in the presence of visual distortion;

1.928 Gain of vestibular nystagmus: effect of object distance;

1.929 Vestibular nystagmus: effect of attention;

3.210 Vestibular illusions

1.927 Vestibulo-Ocular Reflex in the Presence of Visual Distortion

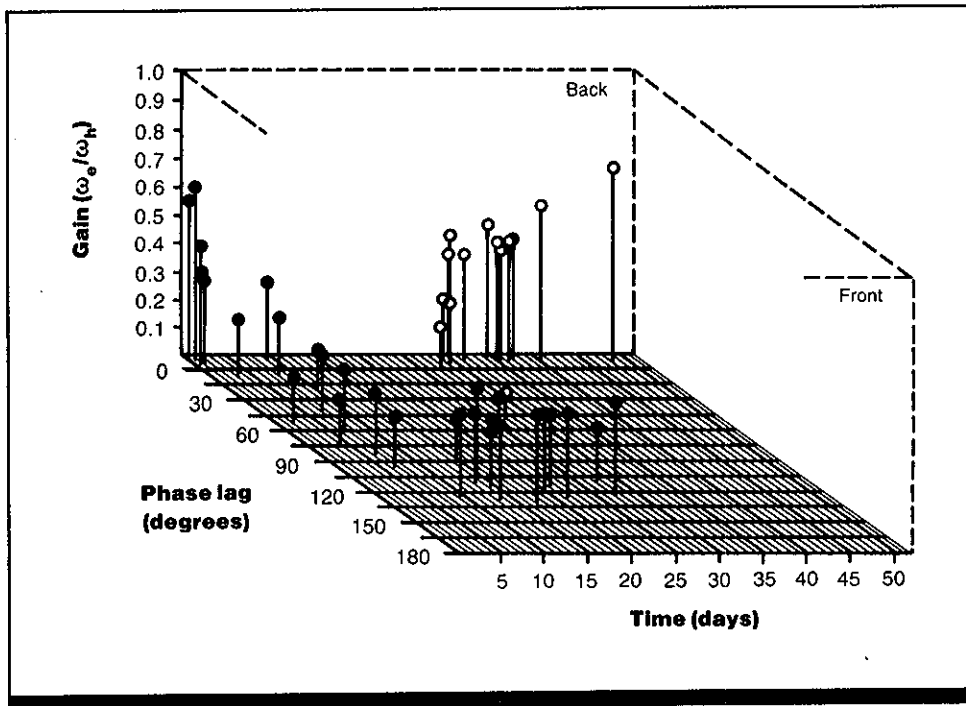

Figure 1. Three-dimensional representation of the interaction of gain, phase, and time for one observer before, during, and after visual field reversal (Study 1). Symbols indicate the values obtained for a test run in the dark before (half-filled circles), during (filled circles), and after (open circles) the period of maintained vision reversal. (From Ref. 4)

Key Terms

Compensatory eye movements; disorientation; electro-oculography; eye-head coordination; head rotation; perceptual adaptation; simulation; vertigo; vestibulo-ocular reflex; visual distortion; visual fixation; visual-vestibular interaction

General Description

The vestibulo-ocular reflex undergoes recalibration when the world is viewed through reversing magnifying or minifying lenses that produce a mismatch between the visual and vestibular inputs. This visually driven recalibration takes the form of an adjustment and perhaps even a change in sign

of the gain of the vestibulo-ocular reflex. (Gain is defined as the ratio of the peak magnitudes of the eye and head angular velocities.) While recalibration is taking place, visual instability is experienced when the head is moved. Further, after recalibration has taken place and the optical characteristics are changed back to normal, there is again a period of visual instability when the head is moved.

Applications

Operational or simulated environments where use of prisms or lenses in viewing displays or the environment can produce impairment of vision, as well as headache and nausea.

Methods

Test Conditions

Study 1 (Ref. 4)

- Observer exposed to a visual environment that was horizontally reversed by Dove prisms; awake exposure 2, 6, 7, and 27 days; continuity of exposure was rigorously maintained
- Observer rotated in plane of horizontal semicircular canals; head immobilized with respect to the body; 20 sinusoidal rotations with frequency of 0.167 Hz; angular

lar velocity amplitude ± 60 deg/sec; horizontal canals at earth horizontal

- Observer rotated as above, but rotations in head sagittal plane; head sagittal plane at earth horizontal

Study 2 (Ref. 3)

- Observer exposed to $2.1 \times$ magnified environment using magnifying lenses for 5 full days
- Observer rotated in the horizontal plane approximately sinusoidally at a frequency of ~ 0.25 Hz and an amplitude of 20 deg

- Observer attempted to live a normal life during time of adjustment

Experimental Procedure

Study 1

- Electro-oculographic recording while observer dark adapted
- Independent variable: duration of exposure to horizontally reversed visual environment
- Dependent variables: peak magnitude of eye horizontal angular velocity, phase, vestibulo-ocular gain
- Observer's task: maintain arousal by performing mental arithmetic

- 1 female and 3 male observers, who were free of vestibular and oculomotor disorders

Study 2

- Electro-oculographic recording while observer dark adapted
- Independent variable: exposure to magnified environment
- Dependent variables: peak magnitude of eye angular velocity, vestibulo-ocular gain
- Observer's task: perform mental arithmetic while in the dark, fixate a real or imaginary target that is either earth- or head-fixed
- 1 male observer

Experimental Results

Study 1

- Vestibulo-ocular gain is reduced during the first 2 days of vision-reversal to ~60%; after a week it is reduced to ~25% of the normal value.
- Phase of the vestibulo-ocular reflex lags relative to normal perfect compensatory eye movement by ~130 deg by the beginning of Week 3, with a corresponding restoration of the gain from 25-50% of its normal (absolute) value.
- On re-exposure to normal visual environment, gain returns to normal values along a time course similar to that of the original attenuation.
- No changes in gain and phase are observed when observer is oscillating in the sagittal plane.

Study 2

- Gain increases from 0.61 ± 0.07 standard deviation (SD) to 1.08 ± 0.14 SD after 5 days of adaptation when measurements are made with observer performing mental arithmetic in the dark.
- Gain increases from 1.0-2.0 when fixating on a visible target attached to a stationary wall; gain increases from 0.81 ± 0.12 SD to 1.24 ± 0.15 SD when fixating in the darkness on an imaginary target on wall.
- Gain remains at 0 when observer is fixating on a visible

Constraints

- Warning: In an aerospace environment, these experiments are dangerous both during the experiment itself and afterwards.
- Results may vary for exposure to vertical reversal of vision, or for frequencies and amplitudes of the test oscillations different from those employed here (Ref. 7).

Key References

1. Cannon, S. C., Leigh, R. J., Zee, D. S., & Abel, L. A. (1985). The effect of the rotational magnification of corrective spectacles on the quantitative evaluation of the VOR. *Acta Otolaryngologica*, 100, 81-88.
2. Collewijn, H., Martins, A. J., & Steinman, R. M. (1983). Compensatory eye movements during active and passive head movements: Fast adaptation to changes in visual magnification. *Journal of Physiology*, 340, 259-286.
- *3. Gauthier, G. M., & Robinson, D. A. (1975). Adaptation of the human vestibular-ocular reflex to magnifying lenses. *Brain Research*, 92, 331-335.
- *4. Gonshor, A., & Melvill Jones,

- G. (1976). Extreme vestibulo-ocular adaptation induced by prolonged optical reversal of vision. *Journal of Physiology*, 256, 381-414.
5. Hay, J. C., & Goldsmith, W. M. (1973). Space-time adaptation of visual position constancy. *Journal of Experimental Psychology*, 99, 1-9.
6. Jager, J., & Henn, V. (1981). Vestibular habituation in man and monkey during sinusoidal rotation. *Annals of the New York Academy of Sciences*, 374, 330-339.
7. Melvill Jones, G., & Gonshor, A. (1982). Oculomotor responses to rapid head oscillation (0.5-5.0 Hz) after prolonged adaptation to vision-reversal. *Experimental Brain Research*, 45, 45-58.

Cross References

- 1.907 Adaptability of eye movements;
- 1.909 Maladaptive eye movements: eliciting conditions;
- 1.917 Factors affecting the vestibulo-ocular reflex;
- 1.918 Factors influencing visual suppression of vestibular nystagmus;
- 1.926 Factors affecting gain of vestibulo-ocular reflex;
- 3.209 Long-term adaptability of the vestibular system;
- 3.210 Vestibular illusions;
- 5.1102 Visual effects of various optical devices;
- 5.1114 Perceptual effects of inversion and left-right reversal of the visual field

target attached to chair rotating with observer; gain increases from 0.18-0.45 when fixating in the darkness on an imaginary target on rotating chair.

- Immediately after removal of the lenses, 30-50% over-compensation of eye movements occurs on attempting to fixate an invisible target when observer is rotated in the dark; fixation occurs when the target reappears, but the target appears to have moved in the direction of chair rotation during the dark.
- When observer is rotated in the light, target is fixated with no over-compensation, but the target appears to move with the rotating chair.

Variability

In Study 1, the standard error of the mean gain ranged from 0.005-0.031 (average 0.011) for measurements made while prisms were worn and from 0.004-0.016 (average 0.008) for measurements made after prisms were removed; for phase, standard errors of the mean ranged from 0.98-11.77 (average 4.50) during prism wearing and from 0.87-7.88 (average 1.84) after prism removal. (Each mean was based on 7-23 measurements.) Standard deviations for vestibulo-ocular gain measured in Study 2 are indicated in the section above.

- Other factors may also modify gain and phase of the vestibulo-ocular reflex (Refs. 5, 6; CRefs. 1.917, 1.926).
- In Study 2, masking goggles restricted the visual field.
- Adaptation to magnification can occur much more rapidly than reported here if the magnification is smaller (Ref. 2).

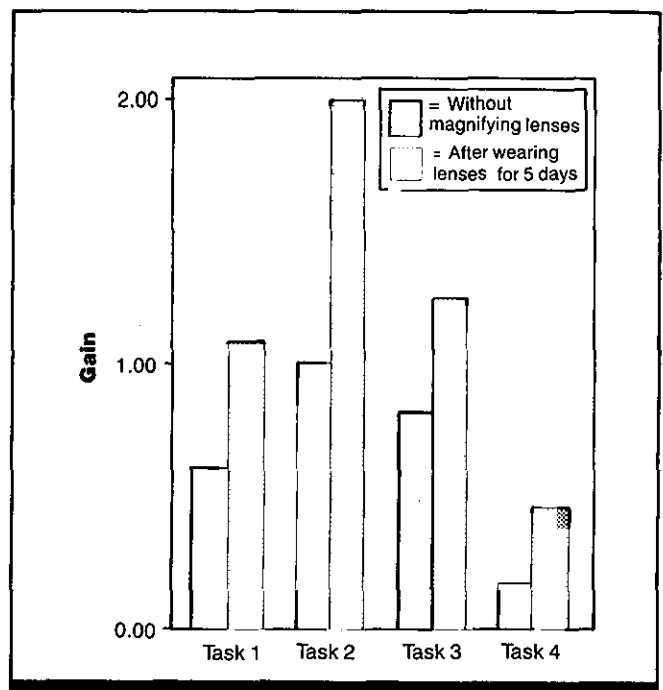

Figure 2. Gain of vestibulo-ocular nystagmus after observer wore magnifying lenses for 5 days (Study 2); values obtained without lenses are shown for comparison. Task 1: observer performed mental arithmetic in the dark; Task 2: earth-fixed target visible and fixated; Task 3: imaginary earth-fixed target fixated in dark; Task 4: imaginary head-fixed target fixated in dark. (Data from Ref. 3)

1.928 Gain of Vestibular Nystagmus: Effect of Object Distance

Key Terms

Compensatory eye movements; convergence; head rotation; helmet-mounted displays; optokinetic nystagmus; retinal image stability; vestibular gain; vestibular nystagmus; visual fixation; visual position constancy

General Description

The gain of vestibular nystagmus produced by head rotation is defined as the ratio of the compensatory angular velocity of the eyes during the slow phase to the angular velocity of the head (with sign reversed). If eye and head rotations were about the same axis, then with a gain of 1 the slow phase of vestibular nystagmus would compensate exactly for head rotation and so stabilize the retinal image. However, because the eyes and head rotate about separate parallel axes, rotation of the head produces both a translation and a rotation of the eyes. If the retinal image is to be stabilized, the additional effect of the translation of the eye must be taken into account by a change in the slow phase and hence in the gain of vestibular nystagmus.

An expression for rotation that compensates for the effect of both eye rotation and translation is

$$\theta + \arctan \frac{d \sin \theta}{D}$$

where θ is the head rotation, d is the distance of the nodal point of the eye from the axis of head rotation, and D is object distance. The second term of this expression, which gives the angular compensation for eye translation, is negligible for distant objects and approaches the value of θ for near objects. Consequently, compensatory eye rotation (and therefore the velocity of eye movements required to stabilize the retinal image of near objects) will be approximately double that required for far objects. This means that the gain of vestibular nystagmus varies with object distance, from a value of 2 for near objects to ~ 1 for far objects.

Adjustment of the gain of vestibular nystagmus with object distance may be related to the convergent state of the eyes (Refs. 1, 2).

Applications

Alternation between viewing the distant environment and nearby displays under conditions of head rotation requires changes in the value of the gain of vestibular nystagmus for successful retinal image stabilization.

Constraints

- Gain of vestibular nystagmus must be measured in the dark to avoid confounding vestibular nystagmus with optokinetic nystagmus.

Key References

1. Hay, J. C., & Sawyer, S. (1969). Position constancy and binocular convergence. *Perception & Psychophysics*, 5, 310-312.

2. Post, R. B., & Leibowitz, H. W. (1982). The effect of convergence on the vestibulo-ocular reflex and implications for perceived movement. *Vision Research*, 22, 461-465.

Cross References

1.907 Adaptability of eye movements;
1.915 Effects of target characteristics on eye movements and fixation;

1.917 Factors affecting the vestibulo-ocular reflex;
1.926 Factors affecting gain of vestibulo-ocular reflex;

1.927 Vestibulo-ocular reflex in the presence of visual distortion;
1.929 Vestibular nystagmus: effect of attention

Notes

✓

✓

✓

✓

1.929 Vestibular Nystagmus: Effect of Attention

Table 1. Median values of several indices of warmth-induced nystagmus. (From Ref. 3)

Test Condition	Duration of Nystagmus	Maximum Velocity Slow Phase	Velocity 1 min (deg/sec)	Total Number Beats	Maximum Number Beats	Ratio Beats Duration	Total Amplitude (10 sec)	Mean Amplitude (10 sec)
I	134	22.1	15.9	77	12	0.52	46	3.2
II	0	0	0	0	0	0	0	0
III	165	27.7	20.9	101	15	0.65	93	6.0

Test Condition I: no fixation (eyes closed) and no assigned mental task; Test Condition II: target fixation and assigned mental task; Test Condition III: no fixation (eyes closed) but assigned mental task.

Key Terms

Attention; degraded eye movement; nystagmus; spatial orientation; vertigo; vestibular nystagmus; vestibulo-ocular reflex; visual fixation

General Description

The level of attention of an observer influences the strength of vestibular nystagmus. States of relaxed attention (reverie) weaken the nystagmus, whereas a more vigorous nystagmus is produced when the observer is alert and performing some demanding mental activity.

Applications

Low levels of attention can produce degraded eye movements that result in impairment of vision.

Methods

Test Conditions

- Observer's left ear (external auditory meatus) irrigated with water at 44°C for 40 sec; observer supine in dark with head slightly flexed
- Illuminated fixation target 1 cm in diameter and 140 cm from observer's eyes

- Mental-activity task of serial-7 subtraction
- Eyes closed and no assigned mental task (Condition I), target fixation and assigned mental task (Condition II), and eyes closed and assigned mental task (Condition III)

Experimental Procedure

- Electro-oculographic recording of warmth-induced nystagmus
- Independent variables: presence or absence of assigned mental-task, presence or absence of visual fixation
- Dependent variables: indices of warmth-induced nystagmus (see Table 1)

- Observer's task: close eyes or fixate on target; perform mental arithmetic or relax
- 3 female and 3 male observers clinically free of ear pathology, with no history of vertigo or head injury, and had not taken drugs or alcohol during the previous 3 days

Experimental Results

- Median values for all the indices of nystagmus in Table 1 are greatest for the test with attention produced by performing mental arithmetic with eyes closed.
- Median values for indices of nystagmus are least (zero) for the test with attention produced by performing mental arithmetic during visual fixation of a target.

Variability

There is some intro-observer variability that could be some-

what controlled by eliminating the fixation and assuring the presence of mental activity. Physiological differences, as well as different effects of mental tasks, can be used to explain inter-subject variability.

Repeatability/Comparison with Other Studies

Other studies reporting similar results are listed in Ref. 3.

Constraints

- Results may vary for head positions or conditions of mental stimulation that differ from those used in this study.
- Other factors may also modify the indices of nystagmus, and should be taken into account when applying these results under different conditions (Ref. 2).

- The gain of vestibular nystagmus may be increased if the subject imagines a stationary visual object and decreased if the subject imagines an object moving with the head (Ref. 1).

Key References

- | | | |
|--|---|--|
| <p>1. Baloh, R. W., Lyerly, K. & Yee, R. D. (1986). Voluntary control of human vestibulo-ocular reflex. <i>Acta Otolaryngologica</i>, 97, 1-6.</p> | <p>2. Collins, W. E. (1974). Arousal and vestibular habituation. In H. H. Kornhuber (Ed.), <i>Handbook of sensory physiology</i>, Vol. VII/2, New York: Springer.</p> | <p>*3. Sokolovski, A. (1966). The influence of mental activity and visual fixation upon caloric-induced nystagmus in normal subjects. <i>Acta Otolaryngologica</i>, 61, 209-220.</p> |
|--|---|--|

Cross References

- | | | | |
|---|--|--|--|
| <p>1.917 Factors affecting the vestibulo-ocular reflex;</p> <p>1.919 Visual suppression of vesti-</p> | <p>bular nystagmus: effect of direction of head inclination;</p> <p>1.926 Factors affecting gain of vestibulo-ocular reflex;</p> | <p>1.927 Vestibulo-ocular reflex in the presence of visual distortion;</p> | <p>1.928 Gain of vestibular nystagmus: effect of object distance</p> |
|---|--|--|--|

1.930 Vestibular Nystagmus: Effect of Angular Acceleration and Deceleration

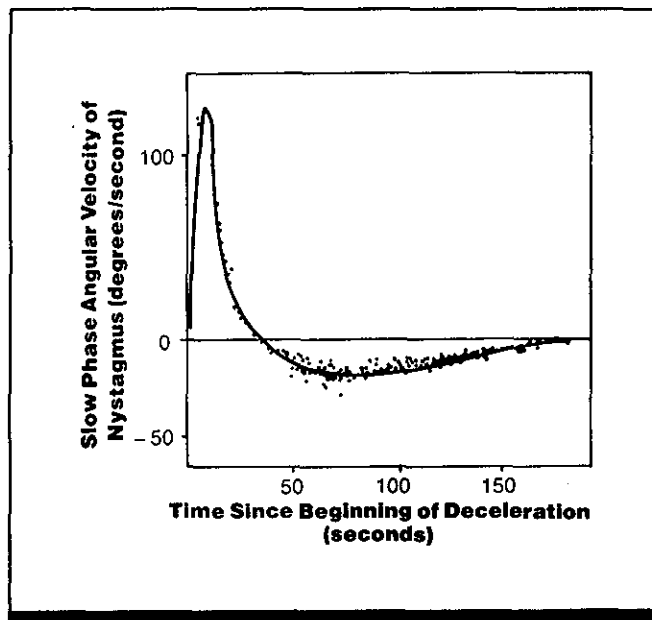

Figure 1. Nystagmus produced by exposure of one subject to strong angular deceleration lasting 10 sec (beginning at time zero) from a constant rotational velocity of 270 deg/sec. (From Ref. 3)

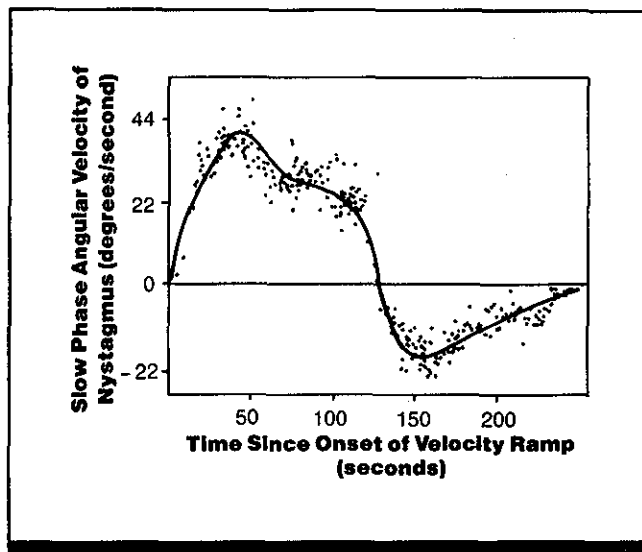

Figure 2. Nystagmus produced by exposure of one subject (same as in Fig. 1) to a velocity ramp generated by acceleration of 4.5 deg/sec² lasting 120 sec; angular velocity passed from maximum in one direction at 0.0 sec to maximum in opposite direction at 120 sec (marked by arrow). (From Ref. 3)

Key Terms

Angular acceleration; angular deceleration; electro-oculography; nystagmus; vestibular illusions; vestibular nystagmus; visual fixation; visual-vestibular interaction

General Description

Angular (rotary) acceleration of the body produces a nystagmus that is in phase with the perrotary response. Large-magnitude angular deceleration or cessation of constant acceleration produces a period of anti-phase postrotary nys-

tagmus that is in the opposite direction and that lasts from 20-30 sec (Fig. 1). The cessation of this postrotary nystagmus reveals a weaker secondary or post-postrotary nystagmus (shown with negative velocity in Fig. 1).

Applications

Prolonged and/or large angular acceleration or deceleration in the aerospace environment may produce illusions of rotary movements, biased impressions of attitude (the "leans"), and impairment of visual fixation.

Methods

Test Conditions

- Observer exposed to step change from an angular velocity of 270 deg/sec maintained for 3 min to 0 deg/sec within 10 sec
- Observer exposed to an angular acceleration of 4.5 deg/sec² lasting

120 sec; head fixed to rotating chair by dental bite; after constant rotation for 3 min, chair driven to follow required acceleration down a velocity ramp through zero angular velocity to a constant angular velocity in the reverse direction

- Observers dark-adapted in red light for a minimum of 50 min before each test; tests run in complete darkness

Experimental Procedure

- Electro-oculographic (EOG) recording with observer's eyes closed
- Independent variable: elapsed time after change in angular velocity

- Dependent variable: magnitude of angular eye velocity during slow phase of nystagmus
- Observer's task: maintain arousal by performing mental arithmetic for monetary reward
- 3 normal males and 5 normal females (ages 18-39), with an unknown amount of practice

Experimental Results

- Strong deceleration of short duration (a step change in angular velocity) yields initial anti-phase postrotary nystagmus that stops in ~30 sec. There follows an in-phase secondary nystagmus with a slow phase that increases in angular velocity and then declines toward zero for ~100 sec (Fig. 1).
- Anti-phase nystagmus occurs with onset of a velocity ramp (Fig. 2). The slow-phase velocity initially increases, reaches a maximum at ~50 sec, and then decreases. The nystagmus then reverses direction with velocity reaching a maximum at ~150 sec after ramp onset.
- Mean canal cupular restoration time constant underlying the time course of nystagmus at onset and cessation of angular acceleration is 21 sec.
- Mean adaptive time constant underlying the time course

of declining nystagmus under constant acceleration (adaptation) and secondary nystagmus is 82 sec.

Variability

- Standard deviation of canal cupular restoration time constant was 5.9 sec and standard error was 1.5 sec.
- Standard deviation of adaptation time constant was 25.8 sec and standard error was 6.5 sec.

Repeatability/Comparison with Other Studies

Latency of vestibular nystagmus (when eye movement is first visible) is a function of the rate of acceleration (e.g., 0.5 sec for 8 deg/sec, but several seconds for 1 deg/sec), and variability decreases as rate of acceleration increases (Ref. 2).

Constraints

- Exposure to rotational velocities and/or large-magnitude accelerations is dangerous.
- Adaptation to constant acceleration is never complete.

- Results may vary for exposure to angular accelerations different from those employed here (Ref. 1).
- Other factors may modify the time constant values and should be considered when applying these results under different conditions.

Key References

1. Brown, J. H., & Wolfe, J. W. (1969). Adaptation to prolonged constant acceleration. *Acta Otolaryngologica*, 67, 389-398.

2. Fluor, E., & Mendel, L. (1966). Relation between strength of stimulus and duration of latency time in vestibular rotatory nystagmus. *Acta Otolaryngologica*, 61, 463-474.

*3. Malcolm, R., & Melvill Jones, G. (1970). A quantitative study of vestibular adaptation in humans. *Acta Otolaryngologica*, 70, 126-135.

Cross References

- 1.921 Vestibulo-ocular nystagmus during and after aircraft spin;
- 1.923 Factors influencing duration of postrotary nystagmus;

- 1.926 Factors affecting gain of vestibulo-ocular reflex;
- 3.202 Dynamics of the otolith organs

1.931 Duration and Amplitude of Saccades in the Absence of Targets

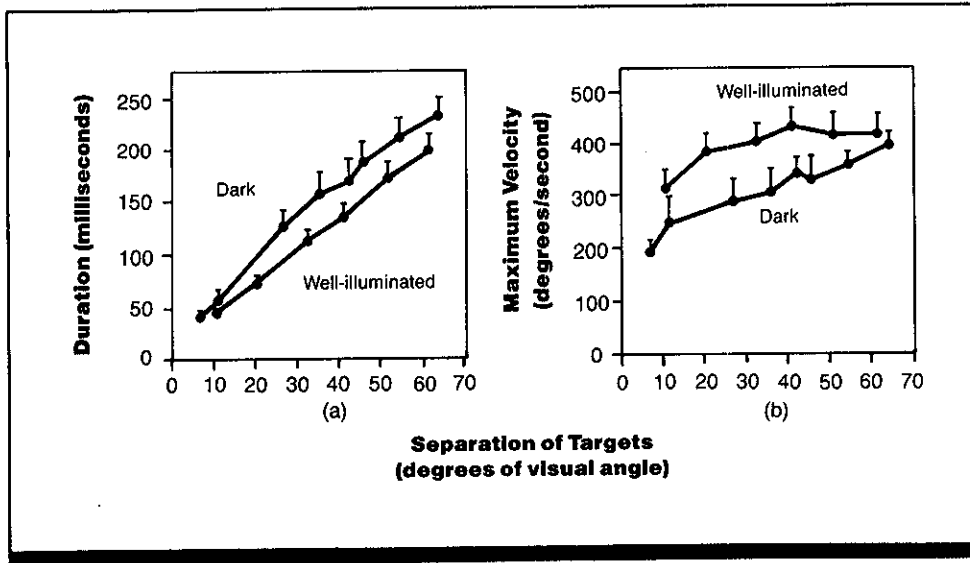

Figure 1. (a) Saccadic duration and (b) maximum velocity of eye movements between well-illuminated fixation points and eye movements in the dark for a representative observer. Each point is the mean of at least 10 values; the bars represent the standard deviation of the mean. (From Ref. 1)

Key Terms

Dark saccades; horizontal eye movements; saccadic eye movements; target acquisition

General Description

The saccade is a rapid and abrupt jump made by the eye as it moves from one fixation point to another. The most common form of eye movement, saccades are primarily used to search and explore the visual field, such as reading or examining a visual scene. Generally, the saccade is regarded as a ballistic eye movement whose trajectory cannot be altered once begun. The mean duration for a saccade of a given magnitude is very predictable, and saccadic movements exhibit remarkably reproducible trajectories (Ref. 1). However, the execution of normal saccadic eye movements depends on the presence of clearly visible fixation points. The following characteristic features distinguish eye movements and gaze fixation in the dark from those observed when targets are visible.

For a pair of targets separated by 10-60 deg of visual angle, when horizontal saccades are made between remembered target positions (targets extinguished at least 1 sec before), saccade duration is longer and maximum velocity of eye movements lower than for similar-sized saccades between always-visible points (see Fig. 1).

Dark saccades are slowed down from their inception. Figure 2a and c shows that dark saccades have a noticeably smaller initial slope than visible target saccades. How-

ever, the slowing is greater for the second half of the movement than for the first half.

Saccades in well-illuminated but uniform visual fields devoid of fixation points are similar to those in darkness (see Fig. 2c and d), suggesting that saccadic slowing can be prevented by one or two simple fixation points; an otherwise patterned visual field and total illumination play no role.

Eye movements under closed eyelids show variable trajectories, but the movement durations are longer and the velocities lower than those of dark eye movements (Fig. 2).

Saccades previously practiced with visible targets separated by <50 deg gradually become larger when the targets are extinguished; when the visible targets are separated by >60 deg, the dark saccades become smaller.

At the end of each saccade the eyes drift toward the primary position, with a velocity proportional to the eccentricity of gaze: 3 min arc/sec per deg of eccentricity (Fig. 3).

Consecutive saccades can be executed with reasonable accuracy based on remembered target locations. The saccade to target 1 extinguished all targets in 50% of trials. The mean error in fixation of target 3 was only 10% greater than the mean error for target 2 (Ref. 3).

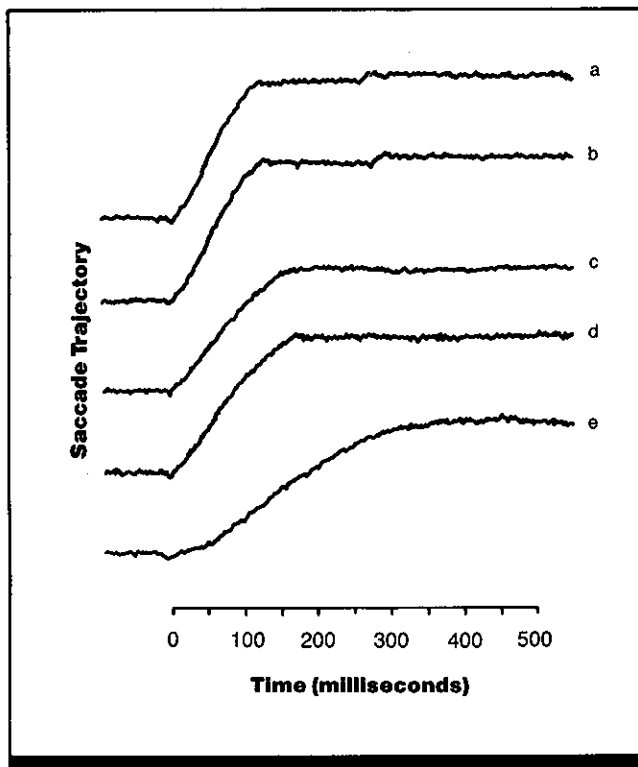

Figure 2. A comparison of saccadic trajectories obtained with and without visual fixation points: (a) normal saccade in a well-illuminated room; (b) saccade between two dim fixation points in an otherwise dark room; (c) saccade in complete darkness; (d) saccade in a homogeneous, well-illuminated visual field; (e) eye movement with closed eyes. In all cases, 40-deg eye movements typical of each condition were selected. (From Ref. 1)

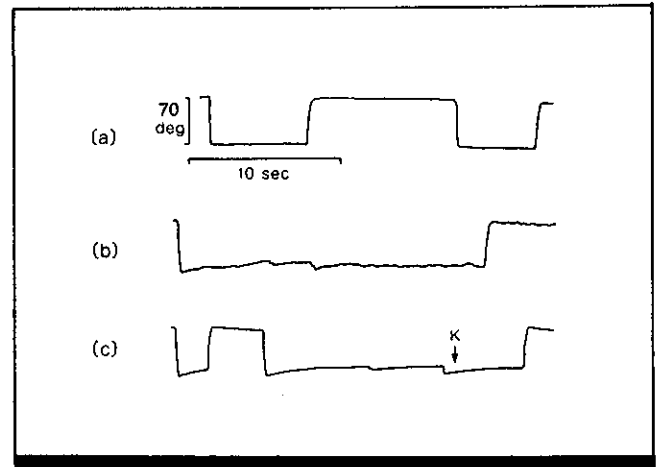

Figure 3. Search saccades, smooth drift, and counter saccades in the dark. After the observer practiced 16 saccades between two dimly lit fixation points, the points were extinguished, and the observer attempted to reproduce the movements in darkness. Electro-oculogram tracing: (a) eye movements and fixation during the learning period; (b, c) large search saccades, followed by drift towards center and small counter saccades that oppose the drift. Point K marks the observer having sensed one of the larger saccades that counter drift. Such experiments demonstrate that observers prefer to make fairly large search saccades of approximately constant amplitude, though amplitude is erratic if the initial fixation points are close, e.g., 5 deg apart. (From Ref. 2)

Constraints

- Results are of unknown validity for longer intervals following target offset, for eye movements in other than a horizontal plane, and for more complex visual fields, or in the presence of vestibular input.

Key References

*1. Becker, W., & Fuchs, A. F. (1969). Further properties of the human saccadic system: Eye movements and correction saccades with and without visual fixation points. *Vision Research*, 9, 1247-1258.

*2. Becker, W., & Klein, H. M. (1973). Accuracy of saccadic eye movements and maintenance of eccentric eye positions in the dark. *Vision Research*, 13, 1021-1034.

3. Komoda, M. K., Festinger, L., & Sherry, J. (1977). The accuracy of two-dimensional saccades in the absence of continuing retinal stimulation. *Vision Research*, 17, 1231-1232.

Cross References

1.904 Methods of measuring eye movements;

1.932 Factors influencing the latency of saccades;

1.935 Patterns and errors in sac-

cadic eye movements: effect of visual task;

1.937 Voluntary control of saccadic eye movements;

7.313 Eye fixations and eye movements during display monitoring;

1.932 Factors Influencing the Latency of Saccades

Key Terms

Amblyopia; luminance; pursuit eye movements; saccadic eye movements

General Description

Saccades are short-duration, high-velocity eye movements made by the observer, for example, to maintain fixation on an object that abruptly shifts position, to track a moving object that suddenly accelerates or changes direction, or to shift visual fixation from one object to another. Since response to a change of object position or the appearance of a new object of interest in the visual field requires activity of sensors, nerves and eye muscles, it cannot be instantaneous.

The length of the delay between the change of position of an object and the start of corrective or compensatory saccadic eye movements to maintain fixation on the object is known as *response latency* (or simply *latency*). Latency is influenced by many factors, some of which are summarized in the accompanying table. These include differences between individuals, as well as observation conditions and target characteristics.

Applications

Any task that requires rapid fixation or refixation will be affected by the viewing conditions and the observer's degree of arousal and proficiency in the situation.

Key References

1. Bartz, A. E. (1962). Eye-movement latency, duration, and response time as a function of angular displacement. *Journal of Experimental Psychology*, *64*, 318-324.
2. Ciuffreda, K. J., Kenyon, R. V., & Stark, L. (1978). Increased saccadic latencies in amblyopic eyes. *Investigative Ophthalmology and Visual Science*, *17*, 697-702.
3. Doma, H. (1980). *An investigation of the effects of different stimuli brightness on the human saccadic oculomotor system*. Master's thesis, University of Toronto.
4. Fitts, P. M., & Posner, M. I. (1967). *Human performance*. Belmont, CA: Brooks Cole.
5. Hallett, P. E., & Adams, B. D. (1980). The predictability of saccadic latency in a novel voluntary oculomotor task. *Vision Research*, *20*, 329-339.
6. Heywood, S., & Churcher, J. (1980). Structure of the visual array and saccadic latency: Implications for oculomotor control. *Quarterly Journal of Experimental Psychology*, *32*, 335-341.
7. Kinsbourne, M. (1972). Eye and head turning indicates cerebral lateralization. *Science*, *176*, 539-541.
8. Mansfield, R. J. W. (1973). Latency functions in human vision. *Vision Research*, *13*, 2219-2234.
9. Robinson, G. H. (1979). Dynamics of the eye and head during movement between displays: A qualitative and quantitative guide for designers. *Human Factors*, *21*, 343-353.
10. Robinson, G. H., Koth, B. W., & Ringenback, J. P. (1976). Dynamics of the eye and head during an element of visual search. *Ergonomics*, *19*, 691-709.
11. Saslow, M. G. (1967). Latency for saccadic eye movement. *Journal of the Optical Society of America*, *57*, 1030-1033.
12. Stark, L., Vossius, G., & Young, L. (1962). Predictive control of eye tracking movements. *IEEE Transactions on Human Factors in Electronics*, *HFE-3*, 52-57.
13. Steinbach, M. J. (1969). Eye tracking of self-moved targets: The role of efference. *Journal of Experimental Psychology*, *82*, 366-376.
14. Wheelless, L. L., Jr., Cohen, G. H., & Boynton, R. M. (1967). Luminance as a parameter of the eye-movement control system. *Journal of the Optical Society of America*, *57*, 394-400.

Cross References

- 1.906 Classifications of eye movements;
- 1.934 Elicitation of saccades: effects of target size and proximity to fovea;
- 7.501 Factors affecting visual search with monochrome displays;
- 7.504 Role of saccadic eye movements in search;

Factor	Description	References
Direction of target motion	Upward motions of the eyes start sooner than downward motions. Oblique movements start later than up or down motions	Refs. 1, 6, 11
Individual differences	There are notable differences, including amount of practice (which decreases latency), handedness, state of alertness (e.g., alcohol increases latency to respond, even in small quantities)	Refs. 6, 10
Handedness	Right-handed individuals show shorter latencies for rightward than for leftward saccades. In addition, righthanders consistently orient to the right after verbal questions, while looking up after numerical questions and up and to the left after spatial questions. Lefthanders, as a group, showed more variability in direction of looking	Ref. 4
Luminance	Time to respond varies as an inverse power function of flash intensity for short flashes; varies directly with luminance for longer flashes, i.e., >10 msec. The effect is independent of retinal locus, spectral composition, and flash duration beyond 10 msec. In some tasks, contrast between target and background influences saccade latency	Refs. 7, 14
Predictability	<p>When an observer controls target motion, target pursuit is quick and accurate; when the target position is correlated with an observer's arm movement, but the arm is passively moved, the tracking is still accurate. When target location is imperfectly associated with arm movement, monitoring is very poorly performed, with little actual tracking</p> <p>With intermittent target presentation, prior knowledge of likely target position may induce appropriate, anticipatory saccades; without prior knowledge, saccades increase in number, and latency increases. Further, if a target disappears during an initial saccade, the eye moves to the intended position of the now-invisible target, if target loss occurs late in the course of the first saccade</p>	Refs. 1, 12, 13
Target locus	<p>When a fixated target moves slightly (≤ 5 min visual angle); micro-saccades sometimes occur</p> <p>When a target moves, eye response latency may increase with increased separation between eye fixation and target (Ref.1). For very large angular separations (40-100 deg), the latencies of the multiple saccades required may not differ, although the total time to refixate may increase (Ref.8)</p> <p>In general, left and right directed eye movements are initiated with equal latency, although righthanders have shorter latencies for rightward saccades. Uncertainty as to left or right location of target does not influence saccadic latency</p>	Refs. 1, 10, 11
Target set size	Generally, the number of different targets exerts no effect on saccade initiation	Refs. 6, 11
Visual defects	Observers with amblyopia have longer latencies for the amblyopic eye to initiate saccades, even after treatment	Ref. 2
Visual warning	In general, saccades begin ~ 200 msec after target movement or appearance, decreasing by ~ 5 msec with advance warning of task onset	Ref. 4

1.933 Saccadic Velocity: Effect of Saccade Distance

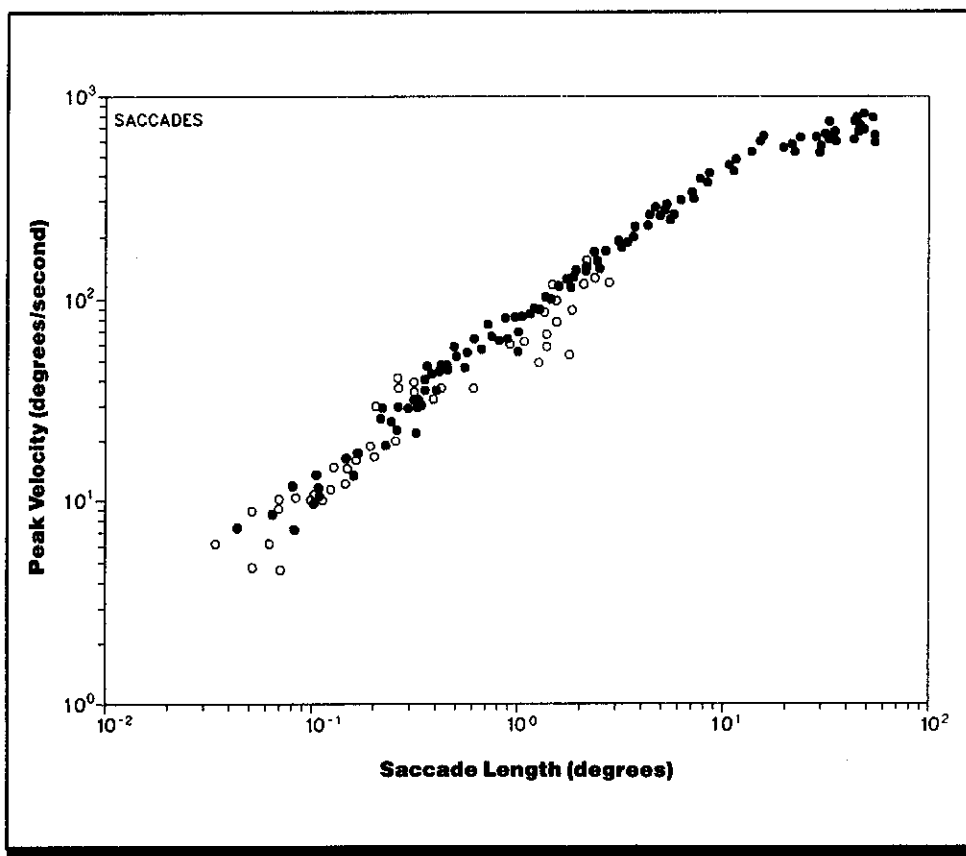

Figure 1. Peak velocities of saccades plotted as a function of saccade length. Filled circles indicate voluntary saccades and open circles indicate small corrective saccades (which typically follow the former). (From A.T. Bahill & L. Stark, *The trajectories of saccadic eye movements*. Copyright © 1979 by Scientific American, Inc. All rights reserved.)

Key Terms

Microsaccades; saccadic eye movements; saccadic velocity; visual direction

General Description

Peak velocity of a saccadic eye movement increases as the length of the saccade increases for both normal voluntary saccades (Ref. 1) and the small corrective saccades which generally follow them, and for involuntary microsaccades (Ref. 2).

Methods

Test Conditions

- Various targets used; details unknown

Experimental Procedure

- Various tasks were used, specifics not given
- Velocities and lengths of voluntary and involuntary eye move-

ments monitored using limbus reflection technique (CRef. 1.904) at a rate of 100 samples per sec

Experimental Results

- The peak velocity of saccades is a nonlinear, increasing function of the length of those saccades.
- Small, corrective saccades are made after normal voluntary saccades, which typically overshoot their target. These small corrective saccades (Fig. 1, open circles) fit on the main sequence with voluntary saccades (filled circles).

Variability

No information on variability was given.

Constraints

- Data from fatigued observers were rejected (CRef. 1.908).
- Drift and noise at the end of the eye movements were ignored.
- Only horizontal eye movements were recorded.
- The actual speed at which observers can traverse a certain

Repeatability/Comparison with Other Studies

An earlier study (Ref. 2) found the same nonlinear relationship between saccade length and peak saccade velocity for involuntary saccades during fixation as did Ref. 1 for voluntary saccades to visible targets. Ref. 2 also showed that microsaccades made during fixations to maintain steady fixation also fall on the main sequence with voluntary saccades.

distance will be slower than indicated by peak saccadic velocities. Velocity changes during a saccade, so peak velocity is not representative, and observers can also make multiple saccades to traverse some distance.

- In darkness, saccades may be slower than in light.
- Saccades to remembered targets may be slower than to visible targets.

Key References

*1. Bahill, A. T., & Stark, L. (1979). The trajectories of saccadic eye movements. *Scientific American*, 240, 108-117.

2. Zuber, B. L., Stark, L., & Cook, G. (1965). Microsaccades and the velocity-amplitude relationship for saccadic eye movements. *Science*, 150, 1459-1460.

Cross References

1.904 Methods of measuring eye movements;

1.908 Effect of fatigue on eye movements;

1.931 Duration and amplitude of saccades in the absence of targets

1.934 Elicitation of Saccades: Effects of Target Size and Proximity to Fovea

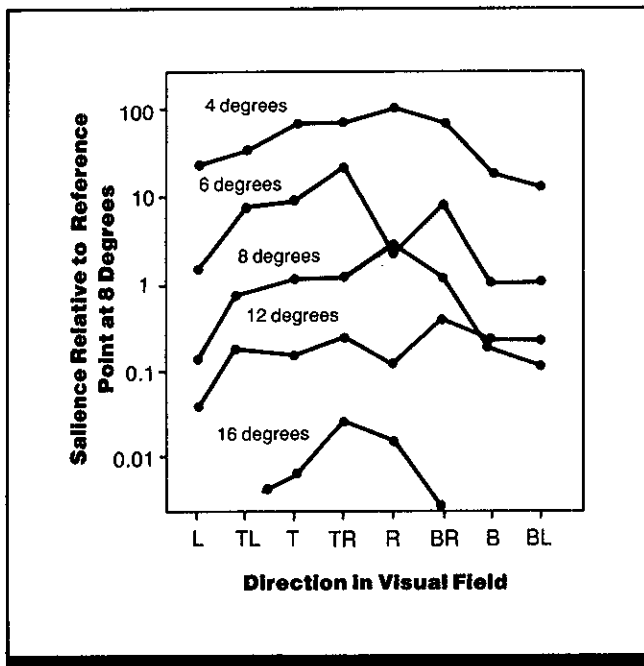

Figure 1. Sallence of stimulus as a function of proximity to fovea. The value of sallence plotted is the rate at the balance point obtained from the PEST procedure. Visual field directions are: L, left; R, right; B, bottom (down); T, top (up). Each point shows the median result (across 5 subjects for 4 and 6 deg; across 3 subjects for the remainder) of trials at a particular target eccentricity and field direction. (From Ref. 2)

Key Terms

Attention; retinal location; saccadic eye movements; visual fixation

General Description

The determinants of the direction of saccades is controversial. If two stimuli appear on either side of a fixation point in an otherwise dark field, a subject is most likely to saccade

to the one closer to the fixation point. To some extent, size can overcome the proximity factor. Contour and movement (at least within the parameters tested) are relatively less effective than proximity as determiners of saccade direction.

Applications

Tasks where it is important for visual attention to be directed to a specific location.

Methods

Test Conditions

• Fixation point appeared for 800 msec, followed by a 100-msec appearance of two square targets, one 8-deg of visual angle from the fixation point and the other at varied distances from fixation (4, 6, 8, 12, or 16 deg); targets appeared on either side of the fixation point (left, right, up, down, or oblique)

- After a 300-msec delay, two indicators (encircled digits) appeared for 100 msec at the prior location of the square target
- Stimuli displayed on oscilloscope screen at end of dark-painted viewing tube; subject's head immobilized by viewing mask and chin rest

Experimental Procedure

- Sequential testing algorithm (PEST) (Ref. 1), order of presentation of different conditions (dis-

tance between target and fixation) balanced across subjects; two randomly-selected digits appearing on each trial

- Independent variables: distance between fixation and target, target size (largest size was 10 x 10 square matrix of points whose side length was 54 min arc)
- Dependent variables: direction of saccade; salience of stimuli,

measured as the median value of the eight balance points (points at which size ratio of targets lead to equivalent likelihood of saccadic direction)

- Subject's task: fixate the center point until onset of display, then read off a digit; subject would only be able to read the digit at the target position to which she had saccaded.
- 6 first-year female undergraduate subjects with 20-20 vision

Experimental Results

- Measure of salience used shows a change of almost 2 log units for a factor of two changes in distance between target and fixation; that is, the closer the stimuli are to the fixation point, the more likely they are to attract a saccade.
- There are directional biases for saccades, in this case, to the right and upper directions; the bias is most likely due to the non-visual environment or intrinsic factors.
- Similar experimental paradigms show that neither apparent motion in the variable stimulus, nor the addition of contour to it, is as strong as the effect of distance between point

of fixation and target in determining the direction of the saccade.

Variability

Considerable individual differences were reported, but the trend of the results was consistent across subjects.

Repeatability/Comparison with Other Studies

This study confirms results first reported by Lévy-Schoen (Refs. 4, 5)

Constraints

- Only a limited number of the possible stimulus parameters that may affect salience have been explored. If targets had been larger in comparison to size of total visual field, the results may have been different.

Key References

1. Findlay, J. M. (1978). Estimates on probability functions: A more virulent PEST. *Perception & Psychophysics*, 23, 181-185.
- *2. Findlay, J. M. (1980). The visual stimulus for saccadic eye

movements in human observers. *Perception*, 9, 7-21.

3. Findlay, J. M. (1981). Local and global influences on saccadic eye movements. In D. F. Fisher, R. A. Monty, & J. W. Senders (Eds.), *Eye movements: Cognition and vi-*

sual perception (pp. 171-179). Hillsdale, NJ: Erlbaum.

4. Lévy-Schoen, A. (1969). Determination et latence de la réponse oculomotrice à deux stimuli simultanés ou successifs selon leur excentricité relative (Determination and latency of the oculomotor response for a simultaneous of successive

stimuli according to their relative eccentricity.) *L'Année Psychologique*, 69, 373-392.

5. Lévy-Schoen, A. (1974). Le champs d'activité du regard: Données expérimentales (The field of observed activity: Experimental data). *L'Année Psychologique*, 74, 43-66.

Cross References

- 1.915 Effects of target characteristics on eye movements and fixation;

1.948 Involuntary anticipatory eye movements;

- 7.406 Characteristics of the signal that affect vigilance, monitoring, and search;

7.511 Search time and eye fixations: effects on symbol color, size, and shape;

- 11.406 Visual warning signals: effects of background color and luminance;

11.407 Visual warning signals: effect of shape;

- 11.409 Visual warning signals: effect of size and location

1.935 Patterns and Errors in Saccadic Eye Movements: Effect of Visual Task

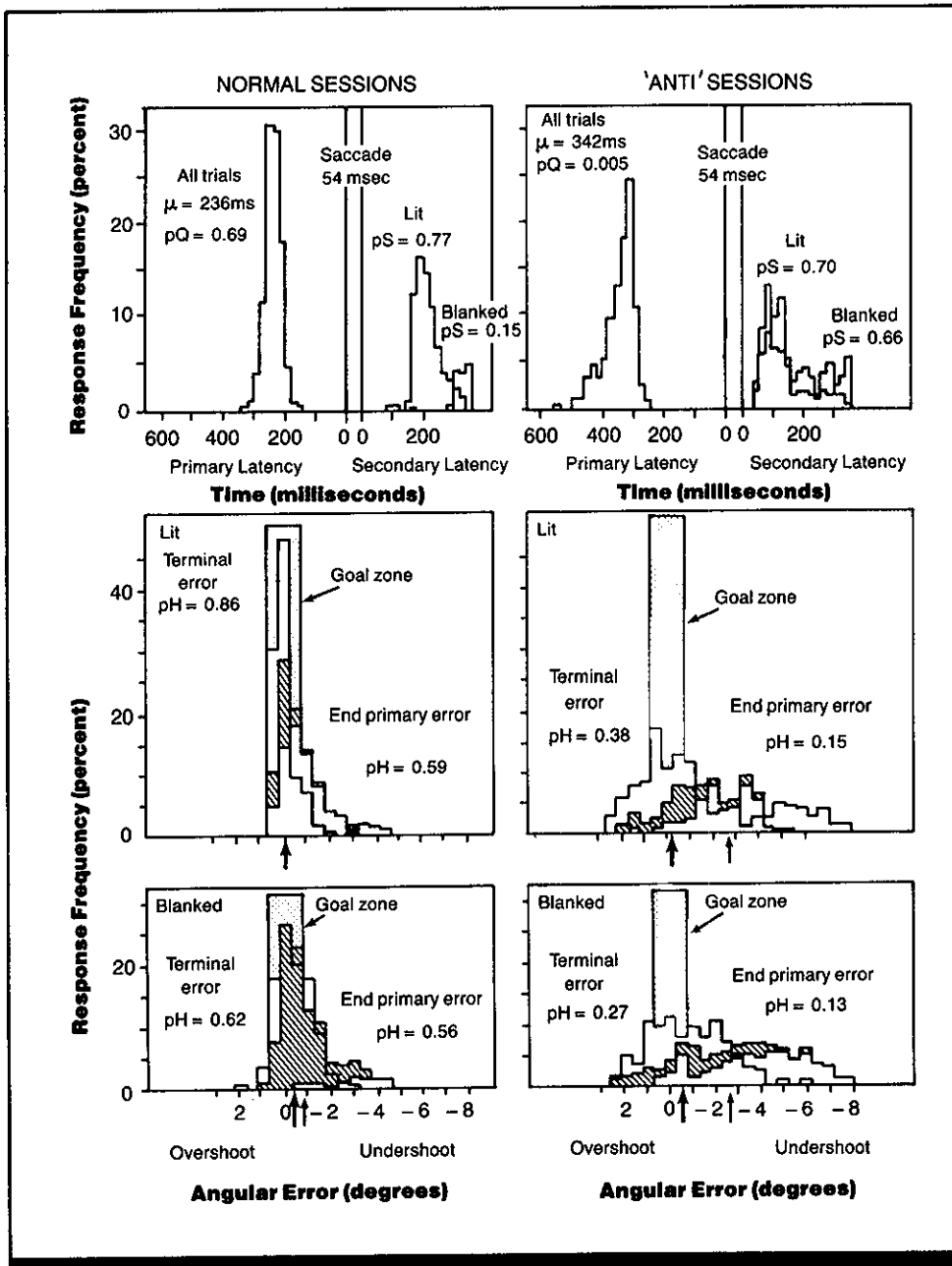

Figure 1. Results from single observer with normal and anti tasks randomly presented, and with the target blanked 50% of the time. In upper panels, latencies of primary saccades are plotted relative to onset of the target (at 0 sec). For secondary saccades, the heavy lines indicate trials during which the target was constantly present; light lines indicate blanked trials. Blanking tended to eliminate most secondary saccades on normal trials, but not on anti trials. pS = proportion of primaries followed by a secondary; pQ = proportion of quick primaries (<250 msec latency). Middle and lower panels plot degree of angular error on lit and on blanked trials. Terminal errors at the ends of the trials are represented with heavy lines; the mean values are indicated by the larger arrows. Terminal errors are increased by blanking in the normal task, but not in the anti location fixation task. Errors at the ends of primary saccades are shown with thin lines and are diagonally shaded, with the mean indicated by the small arrows; unshaded regions are errors which elicit secondaries. pH = proportion of end primary or terminal eye positions that hit the goal zone. End primary errors are equivalent for lit and for blanked trials. (From Ref. 2)

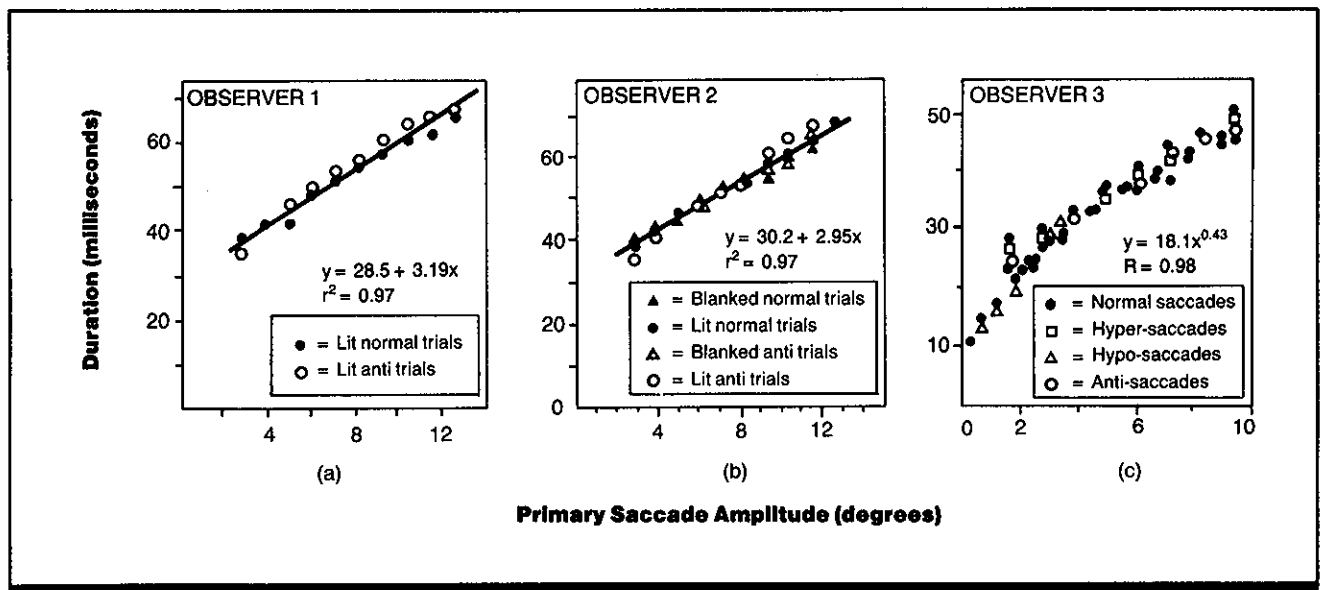

Figure 2. The relationship between the amplitude of the primary saccade and its duration varies by observer. (a) For this observer, anti primaries are slightly longer than normal primaries, ~2 msec, and show anomalous velocity profiles. Filled circles represent normal trials; open circles represent anti location fixation trials. (b) For this observer anti primaries show similar velocities and durations as normal primaries. (c) The primary saccades for this observer show a consistent relationship, best described by a power equation. (From Ref. 2)

Key Terms

Corrective saccades; saccadic eye movements; saccadic latency; visual fixation; visual search

General Description

When attempting to fixate on a visual target that appears on a visual field during a free search task (CRef. 7.504), an observer is likely to **saccade** more than once before finally being able to foveate. These saccades are characterized by short latency and high velocity, if the observer is alert and not fatigued. The nature of the eye movements and errors is partially predictable from the nature of the task, although few tasks have been studied (Ref. 2), and there are considerable individual differences. If instructed to fixate on a spot that might appear in any of several positions, observers

are faster and more accurate initiating saccades. On the other hand, if the fixation point is displaced and they have been told to foveate a spot equidistant from but opposite in direction to the initial fixation point, primary saccades occur later and errors are larger, although, after corrective secondary saccades, fixation and look away tasks show more nearly equal mean errors. Finally, with a fixation task, secondary saccades are nearly always eliminated if the spot to be fixated disappears before the primary saccade ends; with a look away task, the secondary saccades are impervious to the blanking of the stimulus.

Applications

A task which requires the observer to direct fixation at some specified position in *empty space* will likely involve a latency longer than normal and with greater error for the primary saccade. A short-latency secondary saccade will reduce the mean error, but there will be more error variability than in conventional refixation tasks.

Methods

Test Conditions

- Eye movement measured by monitoring horizontal eye movements through non-contacting near-

infrared technique that detects the edges of the pupil

- Target subtending 8 min of visual angle at 100 times foveal threshold; monocular viewing at 72.5 cm; peak-to-peak electrical noise in eye movement monitor

of 6 min; latencies measured to 1 msec-accuracy; technique sensitive only to horizontal movement and impervious to vertical movement or to changes in pupil size;

monocular, left-eye viewing with dark adaptation

- Presentation of target accompanied by tone until initiation of primary saccade; further saccades accompanied by tone pip audible to observer

1.9 Eye Movements

Experimental Procedure

- Mixed presentation of tasks, normal fixation versus "anti" fixation (Ref. 3); separate trial blocks for different tasks (Ref. 2)
- Independent variables: angular displacement of target from initial fixation point, normal fixation task

versus instruction to look in direction opposite to target (antifixation task) by equal distance, presence versus absence of target following initiation of primary saccade

- Dependent variables: latency of saccades, number of saccades, final angular fixation error

- Observer's task: observer-initiated trial consisted of three phases:
 1. Fixation phase, in which observer oriented to visual field
 2. Task phase, in which observer fixation is normal or anti (Ref. 3) and task is executed
 3. Reinforcement task, in which

observer received visual feedback as to accuracy of fixation; 1 observer (Ref. 2) not given feedback

- Approximately 3000 trials for each observer
- 7 adult observers with normal vision in viewing eye (3 in Ref. 2; 4 in Ref. 3)

Experimental Results

- Regardless of feedback condition or type of task (normal or anti), observers generally show large initial or primary saccades that tend to undershoot the actual goal, with subsequent smaller corrective saccades (Fig. 1). The latencies for the Normal responses are usually positively skewed; those for anti response less so. With larger initial errors, secondary saccades are more likely.
- The relationship between angular size of saccade and its duration is predictable and can be described by either a linear or nonlinear relationship, depending on the observer (Fig. 2).
- The latencies for anti tasks are larger than those for normal tasks by 40-120 msec, depending on the individual. With respect to angular errors in achieving foveation or anti-fixation, the anti task produced larger errors at the end of the primary saccade, although the secondary saccades generally reduce these errors. Further, the sizes and velocities of the anti task primary saccades are variable across observers.
- There seemed to be no systematic speed-accuracy trade-

off with respect to latency of the primary saccade and the degree of angular error associated with that saccade.

- Corrective saccades seem to fall into three categories:
 1. Short latency, large corrections, if angular errors are substantial; retinal feedback is not necessary.
 2. Medium-sized corrections for medium errors; the secondary saccades are facilitated by retinal feedback after medium saccadic latency, but without such feedback, may be delayed.
 3. Small corrections that are wholly dependent on retinal feedback.
- Blanking of a visual field after primary saccades have begun affects secondary saccades for normal foveation tasks, but not for the anti task.
- Practice does not reduce overall latency or errors, although some observers fail to accomplish the anti task until they have had some tens of practiced trials.

Variability

Terminal errors are symmetrical about zero, with about 90% of final fixations within 1 deg of the goal in the normal task and 30-40% in the anti task (*pH* in Fig. 1).

Constraints

- Few instructions have been tested and the field of view was dark and devoid of structure.
- Even though primary saccades tend to undershoot their goals, there is overshoot on some trials for all observers, especially for the closer targets.

Key References

1. Becker, W. (1976). Do correction saccades depend exclusively on retinal feedback? A note on the possible role of nonretinal feed-

back. *Vision Research*, 16, 425-427.

*2. Hallett, P. E. (1978). Primary and secondary saccades to goals defined by instructions. *Vision Research*, 18, 1279-1296.

*3. Hallett, P. E., & Adams, B. D.

(1980). The predictability of saccadic latency in a novel voluntary oculomotor task. *Vision Research*, 20, 329-339.

4. Prablanc, C., Masse, D., & Echallier, J. F. (1978). Error-

correcting mechanisms in large saccades. *Vision Research*, 18, 557-560.

5. Robinson, D. A. (1973). Models of the saccadic eye control system. *Kybernetik*, 14, 71-83.

Cross References

1.906 Classification of eye movements;
1.931 Duration and amplitude of saccades in the absence of targets;

1.934 Elicitation of saccades: effects of target size and proximity to fovea;

7.502 Visual search rates with eye movements;

7.503 Effect of head and eye movement on target acquisition;

7.504 Role of saccadic eye movements in search;

7.505 Eye movements during visual search and pattern perception

Notes

1.936 Timing and Accuracy of Saccades to Briefly Lit Targets

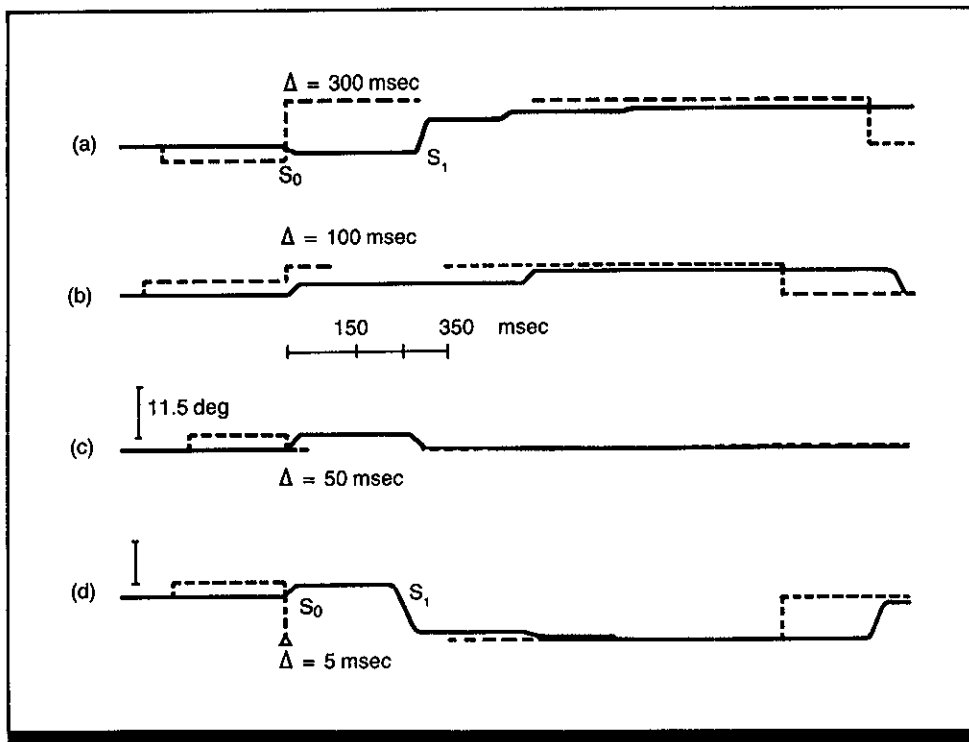

Figure 1. Examples of saccadic responses to briefly lit targets. Target position is indicated by the dotted lines; eye position, by the solid lines. A step in target position elicits saccade S_0 . Saccade S_0 triggers a second target step to a randomly chosen position. After a randomly chosen cue period Δ , the target is blanked for 250-350 msec (represented by break in dotted line) before being re-illuminated (for $\Delta = 5$ msec, Δ is represented by a triangle). (a) Saccade S_1 can be followed by a corrective saccade toward the unlit target, provided that the target is not blanked out before the start of S_1 . (b) There is the tendency for cues (steps) in the direction of the triggering saccade S_0 ("uncrossed cues") to be missed on occasion. (c,d) Short cue periods ($\Delta = 1-50$ msec), which are "intrasaccadic," typically elicit S_1 saccades toward the position of the unlit target, allowance being made for the size and direction of the triggering saccade S_0 . (From Ref. 2, after Ref. 4)

Key Terms

Corrective saccades; dim targets; monitoring; saccadic eye movements; target acquisition; visual fixation; visual search

General Description

When a visual target moves abruptly away from an observer's point of fixation, that individual can, with reasonable accuracy, bring the target into foveal view with one saccade and will subsequently fine tune the fixation with a corrective saccade. The error associated with the first (primary) saccade is typically an undershoot (i.e., the angular amplitude of the saccade falls short of the angular displacement of the

target). The nature of the error depends on a number of factors, including task (CRefs. 1.931, 1.935) and target (CRef. 1.915). When a target is presented only briefly, the observer can still generate corrective secondary saccades, even when the target disappears during the course of the primary saccade. This and related findings suggest that observers can process visual data during saccadic eye movements, at least when the scene is dark except for the target.

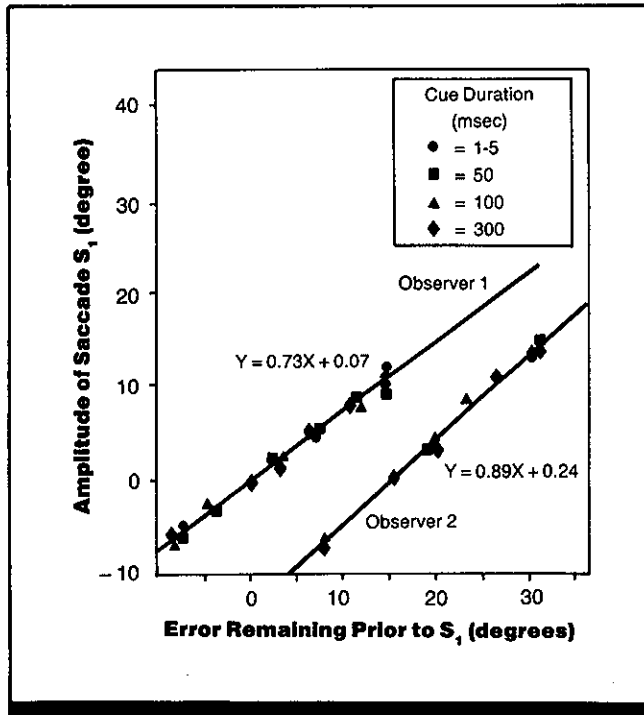

Figure 2. Amplitude of S_1 saccade (in deg of visual angle) versus amount of error prior to the S_1 saccade. Error is calculated as the discrepancy (in deg) between eye position and the actual target location before saccade S_1 . The duration of the cue is 1–5 (\circ), 50 (\blacktriangle), 100 (\blacksquare) and 300 msec (\blacklozenge). One subject's data points are displaced laterally by 15.3 deg. R is the origin for (\circ) data based on retinal position. Many of the closely-positioned points actually overlap, but are illustrated here with a slight scatter. (From Ref. 4)

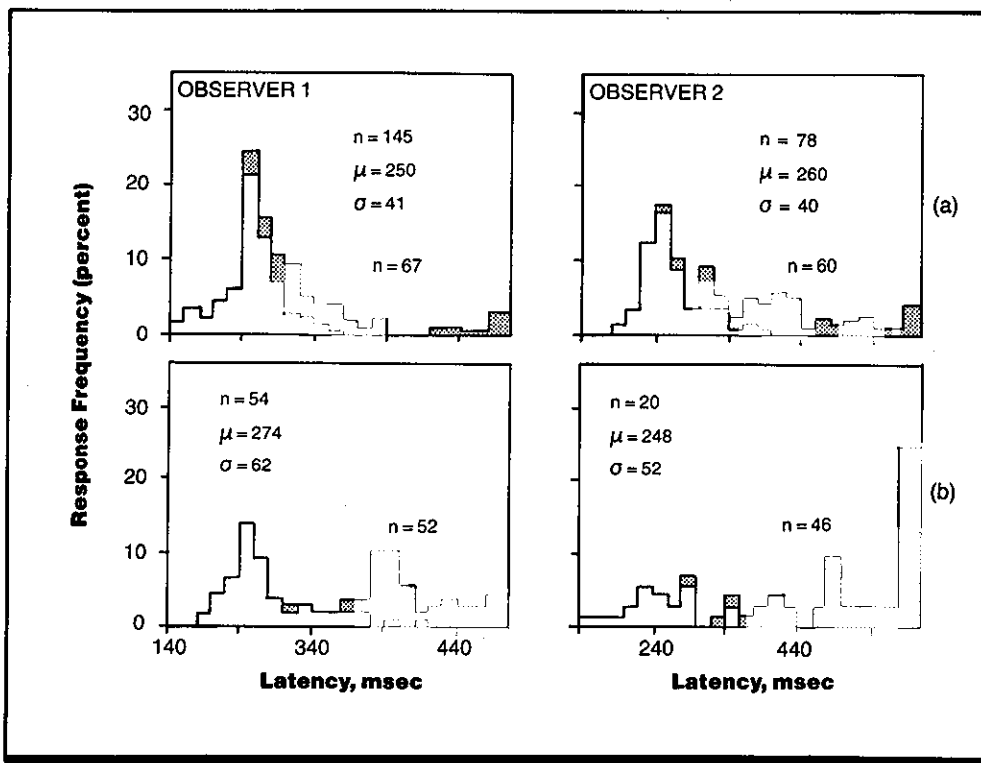

Figure 3. Latencies for S_1 saccades when the duration (D) of the target is 1–50 msec. For such durations, the initial S_0 saccade is not completed before blanking, but S_1 saccades still occur. The shaded areas show latencies of saccades that occur after target reappearance. For crossed cues (a), the delayed saccades are in a long latency tail. For uncrossed cues (b), there seem to be two populations, one showing the effects of missed cues, the other the result of normal variability in response. μ = mean latency and σ = standard deviation for saccades occurring before target reappearance; n = number of trials. (From Ref. 4)

Applications

Tasks requiring an observer to monitor the location of a target that appears briefly, disappears, and reappears in a different location.

Methods

Test Conditions

- Observer viewed oscilloscope screen (very-fast-decay P15 blue-green phosphor) with left eye; right eye occluded; observer's head held stationary via bite board; eye movements recorded by monitoring edges of the pupil with near-infrared light
- Observer completely dark-adapted before experiment

- Target subtended 8 min of arc and was 72.5 cm from observer's eye; target illumination at 2 log units above dark-adapted foveal threshold
- Target motion controlled by PDP8 computer, with clock triggered by eye movements; first movement occurred after a random delay and target returned to origin after series of horizontal steps
- First target step to 3.8 deg left or right elicited saccade S_0 which trig-

gered the second target step when eye velocity exceeded 37 deg/sec; target step was within 11.5 deg, left or right, from the instrument axis, in multiples of 3.8 deg; after exposure for 1-300 msec, the target was blanked for 250-350 msec before being relit and eventually returned to the instrument axis. See Fig. 1.

Experimental Procedure

- Independent variables: exposure time to target, blanking time for

target, amplitude and direction of target movement

- Dependent variables: saccadic accuracy, saccadic latency
- Observer's task: fixate on target at initial location, refixate target at randomly selected horizontal step from initial point (saccade S_0), and at third point which required additional saccade, S_1
- 2 observers with normal vision, trained in related visual search tasks, but not to current experimental conditions

Experimental Results

- Size of saccade S_1 is approximate to physical position of Δ target (Fig. 1) and is unrelated to duration of target presentation (Fig. 2).
- Latency of triggering saccade S_0 is normal and it tends to undershoot the target; corrective saccades are absent until after the next saccade, S_1 .
- With blanking of target during S_0 , the subsequent S_1 saccade still occurs, even though the target is invisible at the beginning of S_1 (Fig. 1d). The degree of undershoot of S_1 is unrelated to duration of target exposure.
- Delayed S_1 saccades occur in some circumstances (Fig. 1b).
- With crossed cues which require the observer to move the eyes in one direction (e.g., right) in S_0 and then in the other direction (left) in S_1 (Fig. 1c, d), late S_1 saccades are almost entirely associated with short presentation times of the target (intrasaccadic cues) (Fig. 3a).

- With uncrossed cues in which the observer's eyes travel in the same direction for the two saccades, delayed or missed S_1 saccades are presumably due to uncertainty as to the location of the target (Figs. 1b, 3b).
- If S_1 ends before the target reappears corrective saccades to S_1 may be delayed (Fig. 1d). The occurrence of a corrective saccade in the dark is critically dependent on the target's being available at least during the early stages of S_1 .
- When the target is blanked out immediately when S_0 begins, there is usually no S_1 , although in 17 of 66 trials, after the target reappeared, there was a second saccade that was always in the same direction as S_0 , which is inappropriate for crossed cue trials.

Variability

Variability of the degree of saccadic eye movement is not sensitive to the amount of time the target is present; the standard error of the mean for the 2 observers is 20% and 14%.

Constraints

- There are sizeable individual differences in latency to initiate saccades.
- Similar behavior may occur in other viewing conditions (Refs. 1, 2).

Key References

1. Gresty, M., & Leech, J. (1976). The assessment of position of stationary targets perceived during saccadic eye movements. *Pflügers Archives*, 366, 83-88.

2. Hallett, P. E. (1976). Saccades to flashes. In R. A. Monty & J. W. Senders (Eds.), *Eye movements and psychological processes*. Hillsdale, NJ: Erlbaum.

3. Hallett, P. E., & Lightstone, A. D. (1976). Saccadic eye move-

ments to flashed targets. *Vision Research*, 16, 107-114.

*4. Hallett, P. E., & Lightstone, A. D. (1976). Saccadic eye movements towards stimuli triggered by prior saccades. *Vision Research*, 16, 99-106.

5. Lévy-Schoen, A., & Blanc-Garin, J. (1974). On oculomotor programming and perception. *Brain Research*, 71, 443-450.

6. Lightstone, A. D. (1973). *Visual stimuli for saccadic and smooth pursuit eye movements*. Doctoral dissertation, University of Toronto.

Cross References

1.915 Effects of target characteristics on eye movements and fixation;

1.931 Duration and amplitude of saccades in the absence of targets;

1.935 Patterns and errors in saccadic eye movements: effect of visual task;

7.501 Factors affecting visual search with monochrome displays;

7.502 Visual search rates with eye movements;

7.504 Role of saccadic eye movements in search;

7.505 Eye movements during visual search and pattern perception

Notes

C

C

C

C

1.937 Voluntary Control of Saccadic Eye Movements

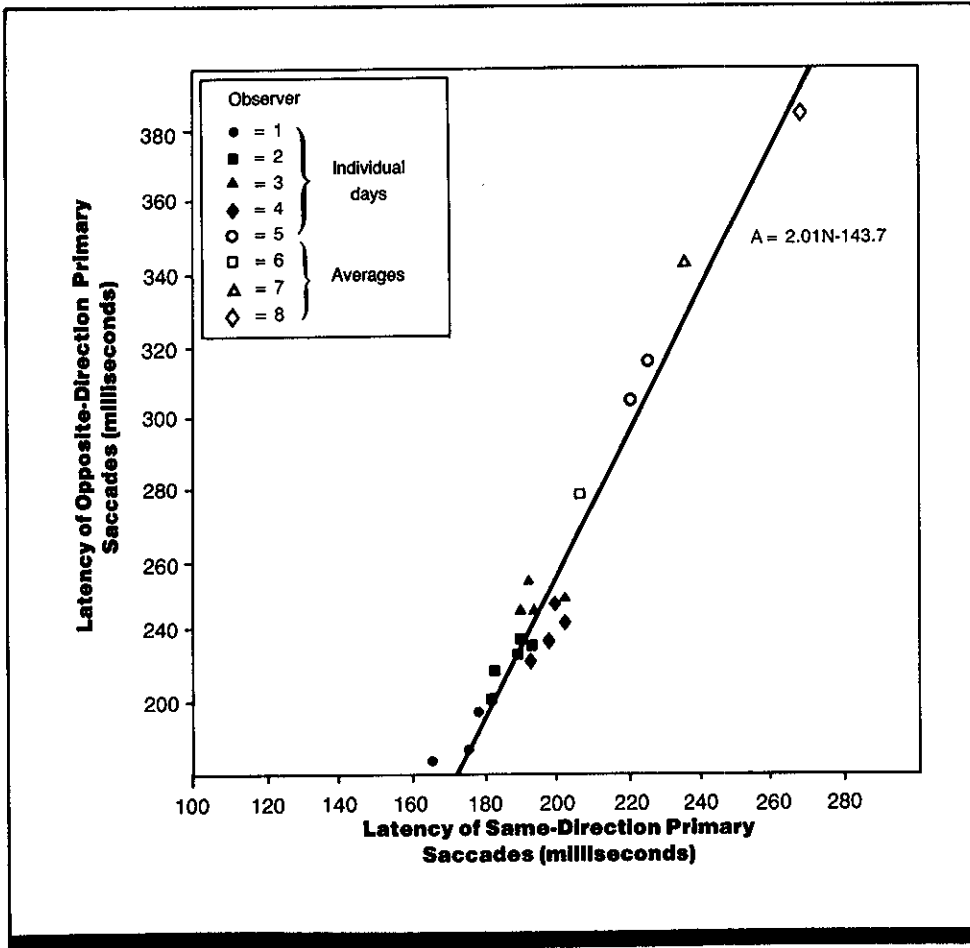

Figure 1. Mean latencies of opposite-direction primary saccades (observer instructed to move eyes in opposite direction from target) as a function of latencies of same-direction primary saccades (observer instructed to move eyes in same direction). (From Ref. 2)

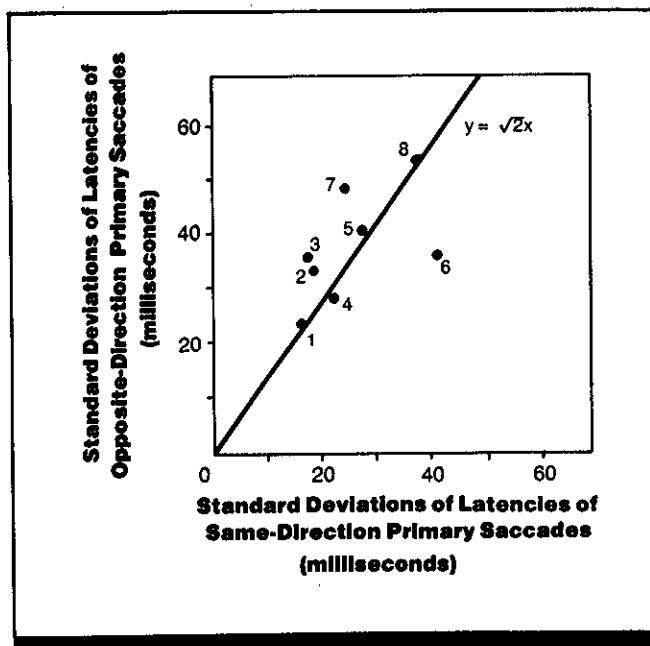

Figure 2. Standard deviations for data in Fig. 1. The slope of the regression line is $\sqrt{2}$. Only the variance ratio for observer is significantly different. (From Ref. 2)

Key Terms

Retinal feedback; saccadic eye movements; saccadic latency; visual fixation

General Description

Observers have a high degree of voluntary control of saccadic eye movements, a fact evidenced by the observers' ability to change the sign (equal magnitude and opposite, direction of target movement), gain (magnitude one-half of target movement), or offset (magnitude a fixed amount greater than target movement) of the first (primary) saccadic response to a target movement. A secondary saccade usu-

ally decreases the error (discrepancy in fixation) from the primary saccade, but the secondary saccade movement is not based on retinal feedback. However, performance for an opposite-movement task is relatively poor (low accuracy and long latency) even after hundreds of trials with high amounts of feedback. Thus saccadic eye movements are primarily designed to locate the target image on the foveal area of the eye.

Methods

Test Conditions

- Horizontal eye movements monitored by tracking pupil edges; dark-adapted observer
- Target was oscilloscope spot subtending 8 min of visual angle and illuminated at 100-times foveal threshold
- Observer triggered trial when

ready; target presented for brief fixation. After delay, target made a horizontal step within ± 11.5 or ± 15.3 deg from straight ahead; target sometimes blanked at start of primary saccade

- Auditory tone presented simultaneously with target movement terminated by primary saccade; tone pip triggered by each saccade
- At beginning of each trial, observer instructed to move eyes in

same direction (normal task) or opposite direction (anti task) as target movement

- Observer instructed to make eye movement one-half as large as target movement, or increase movement to go to next farther possible location, or to same location on opposite side of center

movements (same or opposite direction as target)

- Dependent variables: angular error of observer's fixation, latency of saccade, amount of improvement with practice
- Observer's task: make appropriate eye movement in response to target movement
- 5 observers; figures also include data for 3 observers in nearly identical experiments of Ref. 1

Experimental Procedure

- Independent variable: type of eye

Experimental Results

- Observers can voluntarily control their saccadic eye movements to some degree, but saccades away from the target take longer to begin and undershoot their goals. Performance does not improve with practice.
- There is a mean error of terminal eye position of 0-1 deg for opposite-direction trials, whereas the secondary saccades decrease the errors in same-direction (i.e., track the target) trials by a factor of 2 over opposite-direction error.
- A very similar experiment in Ref. 2 indicates mean opposite-direction primary latency ($\bar{O}p$) in msec is related to mean same-direction primary latency ($\bar{S}p$) by

$$\bar{O}p = 2\bar{S}p - 144.$$

The standard deviations are related by

$$\sigma(O_p) \approx \sqrt{2}(\sigma_p)$$

These formulas hold for both mixed trials and trials blocked

by type of movement (opposite or same direction).

Variability

There are large between-subject differences, particularly in amplitude and latency of the opposite-direction primary saccade. However, both the mean and standard deviation of the latency of the opposite-direction primary saccades of any observer can be predicted from the latencies for the same-direction primary saccades of the same observer (Ref. 2).

Repeatability/Comparison with Other Studies

Reference 3 reports that, when an observer must execute a saccade to superposition a visual target and a point that indicates the position of an eye area other than the fovea, the initial latency is about twice that of a foveating saccade, but, unlike the task discussed above, latency improves with practice and asymptotes near the regular saccadic latency.

Constraints

- Light sources are the only type of stimuli presented.

Key References

*1. Hallett, P. E. (1978). Primary and secondary saccades to goals defined by instructions. *Vision Research*, 18, 1279-1296.

*2. Hallett, P. E., & Adams, B. D. (1980). The predictability of saccadic latency in a novel voluntary oculomotor task. *Vision Research*, 20, 329-339.

3. Zeevi, Y. Y., & Peli, E. (1979). Latency of peripheral saccades. *Journal of Optical Society of America*, 69, 1274-1279.

Cross References

1.906 Classifications of eye movements;

1.934 Elicitation of saccades; effects of target size and proximity to fovea;

7.313 Eye fixations and eye movements during display monitoring;

7.503 Effect of head and eye movement on target acquisition

1.938 Model of Pursuit Eye Movements

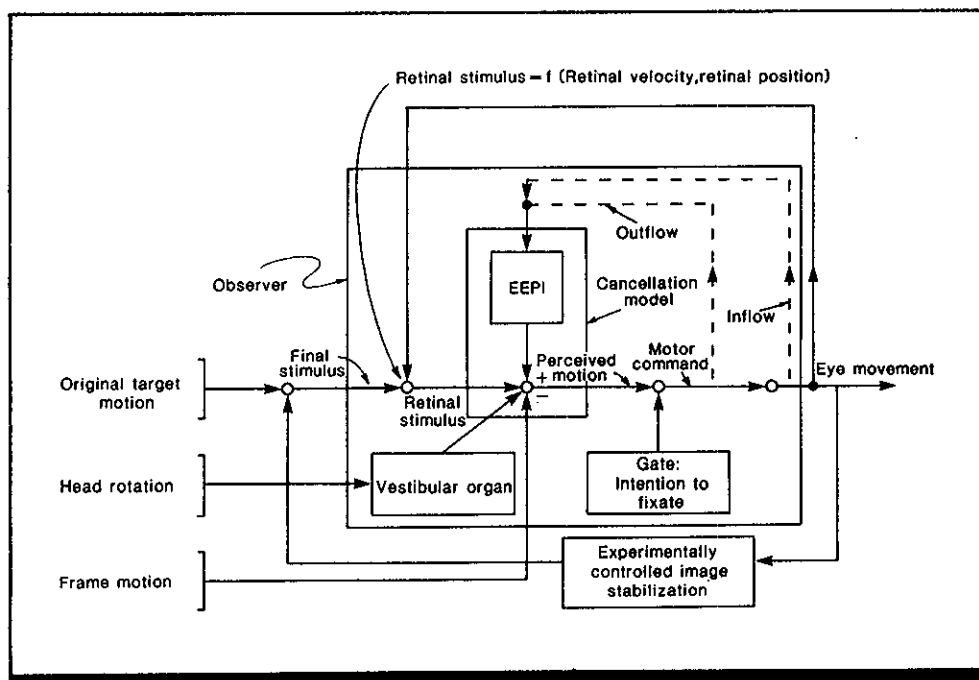

Figure 1. Model of system controlling pursuit eye movements. (From *Handbook of perception and human performance*)

Key Terms

Cancellation theory; pursuit eye movements; target motion; vestibulo-ocular interaction; visual direction; visual fixation; visual localization

General Description

Figure 1 represents a model of the generation of pursuit (slow) eye movement. Eye movement, the model's output, follows a motor command and the intention to fixate, both of which are controlled by the model's main driver, perceived stimulus motions. Perceived motion is determined by multiple sources, including the vestibular system, induced motion due to the configuration on the retina, retinal image motion, and inflow and outflow information about the eye's position.

Evidence that both induced movement and configural variables which affect perceived motion influence pursuit movements includes the following:

- Observers can track the bottom corner of a diamond-shaped image even though the corner is continuously occluded and its motion inferred (Ref. 2).
- Pursuit movements follow perceptual distortions introduced by anorthoscopic presentation (CRef 6.305, Ref. 2).
- Pursuit movements follow the imagined center of a rotating wheel when the retinal stimulus is a point of light moving in a cycloid fashion (CRef. 5.301, Ref. 2).
- Observers can track a stimulus produced by a dynamic random dot stereogram (Ref. 2).

The model posits two channels, one of retinal information (RI) and one of extraretinal eye position information (EEPI), both involved in the Cancellation Theory (for visual localization in the presence of eye movements). This theory explains perceptual stability of visual direction in the presence of eye movements by positing a neural mechanism that subtracts the magnitude of the registered eye movement (EEPI) from the retinal image shift produced by the eye movement. Inflow theory states that EEPI is derived from retrobulbar receptors; outflow theory indicates that EEPI is derived from a signal generated by the observer's motor command to turn the eye. The model suggests that the EEPI generated by an eye movement affects perceived motion via positive feedback to the cancellation mechanism. The system's open-loop gain (eye movement/retinal motion) is large and closed-loop gain = $(\text{open-loop gain}) / (1 - [\text{open-loop gain}] \times [\text{EEPI}/\text{eye movement}])$. There is evidence that non-visual information affects perceived motion and pursuit movements:

- Observers can track the movement of one of their hands in total darkness (Ref. 1).
- Pursuit movements occur when one attempts to maintain fixation on a foveal afterimage which appears to move due to vestibularly induced nystagmus (Ref. 3).

Constraints

- The model does not consider many of the complexities of eye movement dynamics and their relations to the vestibular-ocular linkage.

Key References

1. Steinbach, M. (1969). Eye tracking of self-moved targets: The role of efference. *Journal of Experimental Psychology*, 82, 366-376.

2. Steinbach, M. (1976). Pursuing the perceptual rather than the retinal stimulus. *Vision Research*, 16, 1371-1376.

3. Yasui, S., & Young, L. (1975). Perceived visual motion as effective stimulus to pursuit eye movement system. *Science*, 190, 906-908.

Cross References

1.901 Anatomy and mechanics of eye movements;

1.903 Coordinate systems for describing eye movements;

1.905 Summary of eye movements according to direction and axis of rotation;

1.939 Factors affecting smooth pursuit eye movements;

5.202 Image/retina and eye/head systems of motion perception;

5.301 Induced motion: determinants of objective-relative motion;

5.604 Target localization during pursuit eye movements;

5.606 Target localization accuracy: effect of gaze eccentricity;

6.305 Anorthoscopic perception;

Handbook of perception and human performance, Ch. 20, Sect. 6.3

1.939 Factors Affecting Smooth Pursuit Eye Movements

Key Terms

Attention; expectation; gain; perifovea; phase lag; photopic vision; primary line of sight; retinal location; saccadic eye movements; smooth pursuit eye movements; target acquisition; tracking eye movements

General Description

The table outlines factors which affect smooth pursuit eye movements. Characteristics of the observer (expectation, training, attention) and of the target (saliency, velocity, perceived movement, wavelength, location, luminance, predictability) are included.

Key References

1. Dallos, P. J., & Jones, R. W. (1963). Learning behavior of the eye fixation control system. *IEEE transactions on automatic control*, AC-8, 218-227.
2. Fender, D. H., & Nye, P. W. (1961). An investigation of the mechanisms of eye movement control. *Kybernetik*, 1, 81-88.
3. Goodwin, A. W., & Fender, D. H. (1973). The interaction between horizontal and vertical eye-rotations in tracking tasks. *Vision Research*, 13, 1701-1712.
4. Haegerstrom-Portnoy, G., & Brown, B. (1979). Contrast effects on smooth-pursuit eye movement velocity. *Vision Research*, 19, 169-174.
5. Kowler, E., & Steinman, R. (1979). The effect of expectations on slow oculomotor control. I. Periodic target steps. *Vision Research*, 19, 619-632.
6. Mack, A., Fendrich, R., & Pleune, J. (1979). Smooth pursuit eye movements: Is perceived motion necessary? *Science*, 203, 1361-1363.
7. Michael, J. A., & Melvill Jones, G. (1961). Dependence of visual tracking capability upon stimulus predictability. *Vision Research*, 6, 707-716.
8. Puckett, J., & Steinman, R. M. (1969). Tracking eye movements with and without saccadic corrections. *Vision Research*, 9, 695-703.
9. Rashbass, C. (1961). The relationship between saccadic and smooth tracking eye movements. *Journal of Physiology*, 159, 326-338.
10. Robinson, D. A. (1965). The mechanics of human smooth pursuit eye movement. *Journal of Physiology*, 180, 569-591.
11. Stark, L., Vossius, G., & Young, L. R. (1962). Predictive control of eye tracking movements. *I. R. E. Transactions on Human Factors in Electronics*, HFE-3, 52-57.
12. St. Cyr, G. J., & Fender, D. H. (1969). Nonlinearities of the human oculomotor system: Gain. *Vision Research*, 9, 1235-1246.
13. Steinbach, M. J. (1969). Eye tracking of self-moved targets: The role of efference. *Journal of Experimental Psychology*, 82, 366-376.
14. Steinbach, M. J. (1976). Pursuing the perceptual rather than the visual stimulus. *Vision Research*, 16, 1371-1376.
15. Steinman, R. M., Skavenski, A. A., & Sansbury, R. V. (1969). Voluntary control of smooth pursuit velocity. *Vision Research*, 9, 1167-1171.
16. Westheimer, G. (1954). Eye movement responses to a horizontally moving visual stimulus. *AMA Archives of Ophthalmology*, 52, 932-941.
17. Winterson, B. J., & Steinman, R. M. (1978). The effect of luminance on human smooth pursuit of perifoveal and foveal targets. *Vision Research*, 18, 1165-1172.

Cross References

- | | | | |
|---|---|---|--|
| <p>1.915 Effects of target characteristics on eye movements and fixation;</p> <p>1.940 Gain and phase of smooth pursuit eye movements: effect of target motion;</p> | <p>1.941 Gain of tracking eye movements: effects of target luminance and visual field location;</p> <p>1.942 Latency and velocity of smooth pursuit eye movements: effect of target velocity;</p> | <p>1.943 Visual tracking of random one-dimensional motion;</p> <p>1.944 Visual tracking of complex sinusoidal motion;</p> <p>1.945 Accuracy of tracking eye movements: effect of target velocity;</p> | <p>1.947 Visual tracking: effects of perceived versus real target motion;</p> <p>1.948 Involuntary anticipatory eye movements;</p> <p>9.501 Tactile and visual tracking: effects of error feedback;</p> <p>9.530 Characteristics of display formatting that influence tracking</p> |
|---|---|---|--|

Factor

Attention and Expectation

Effect

In non-stressful situations, observers can generally track a moving target without difficulty. When the task becomes subjectively difficult (e.g., some external threat, unpredictable signals, target moving with high angular velocity, etc.), saccades and head movements are likely to occur frequently. Predictable targets are easy to track, although the observer's attention might waver if the task is very simple. Random targets produce poorer tracking, but may evoke more observer interest if target motion is expected; anticipatory eye movements occur and may be in the direction of expected motion. The nature of the background can modulate the effect, but it cannot be suppressed and occurs without regard to movement characteristics or the experience of the observer at the task. Anticipatory movements begin about 350 msec before target motion, even when the observer cannot predict with certainty the direction of target motion

References

Refs 1, 5, 11;
CRefs 1.948

Factor	Effect	References
Attention and Expectation (cont.)	If a target is presented stroboscopically (i.e., intermittently), an observer may have difficulty visually pursuing it, even when the task could be done easily under conditions of continuous presentation. Performance is improved in the stroboscopic condition if the observer's hand motion is correlated with the motion of the target, (active motion being somewhat better than passive as judged by the less frequent interruption of smooth pursuit by saccades).	Ref. 13
Saliency	Eye movements are highly efficient, regardless of target characteristics such as luminance, size and color. If the target is presented with illumination too low for foveal (i.e., photopic) detection, voluntary control of eye movements diminishes and a more impaired eye motion results (see also Luminance of Target) With a clearly visible target, smooth pursuit velocity to predictable ramp target is almost independent of target/background contrast. Also, eye velocity to unpredictable targets increases with increasing target contrast	Ref. 4; CRef. 1.915
Location of Target	Observers have little difficulty tracking targets that are 5-7 deg below the primary line of sight and will, with practice, begin to show predictive tracking, i.e., appropriate anticipatory eye movements. With smooth pursuit of foveal targets, observers show a slightly greater gain (ratio of eye response to target movement) than with perifoveal (5-7 deg eccentric) tracking	Ref. 15; CRef. 1.941
Luminance of Target	For clearly visible targets, target luminance has little effect on the relationship between eye movement and actual target displacement, although with low luminance levels, the lag between target and eye movement increases somewhat	Ref. 17; CRef. 1.941
Perception of Movement	An observer will be able to track adequately a target being displaced across the retina, even if the perception of motion is illusory. Tracking is optimal for low velocities (e.g., 3 min arc/sec even though the stimulus is not perceived as moving) (Ref. 6). A purely perceptual motion is tracked to a limited extent (Ref. 14)	Refs. 6, 14; CRefs. 1.940, 1.943, 1.944, 1.942, 1.945
Task	When asked to move their eyes at a rate slower than the actual target motion, observers can orient their movements in general accord with the instructions, but they cannot reproduce the actual tracking speed requested. In general, they show smooth eye movements with instructions to go slower than the target but use saccades to track faster than target velocity	Refs. 6, 7, 8, 9, 12, 15, 16; CRef. 1.947
Predictability	Most of these cases involve predictable motions and it is to be expected that tracking will be relatively insensitive to the nature of the stimulus and task, because the subject is actually responding to an internal model (CRef. 1.948). With unpredictable targets, tracking is generally not accurate (Ref. 8) With sinusoid-based target motion, as the amplitude of target movement increases, the gain (ratio of eye movement to target movement) decreases. When movement is the sum of several sine waves, the gain is much less than for pure sinusoidal motions. Likewise, as predictability decreases, phase lag (time between target and eye movement) increases. Finally, analysis of tracking movements suggests a theoretical minimum time delay of 65 msec	Ref. 8; CRef. 1.948
Velocity of Target	Initiation of smooth pursuit movement (latency) is not a function of target velocity and has an average value of 128 msec when velocity is 5-20 deg/sec (Ref. 9). With slower angular velocity, there is initial smooth pursuit with a relatively late corrective saccade (e.g., at 282 msec with 5 deg velocity), then more smooth movement; with faster targets, the saccades appear earlier (e.g., 224 msec for 20 deg/sec velocity) and may be repeated because of the observer's inability to keep up with such movement	Ref. 10; CRef. 1.942
Wavelength	The wavelength of a target light (470-630nm) appears to have no effect on smooth pursuit tasks	Ref. 3

1.940 Gain and Phase of Smooth Pursuit Eye Movements: Effect of Target Motion

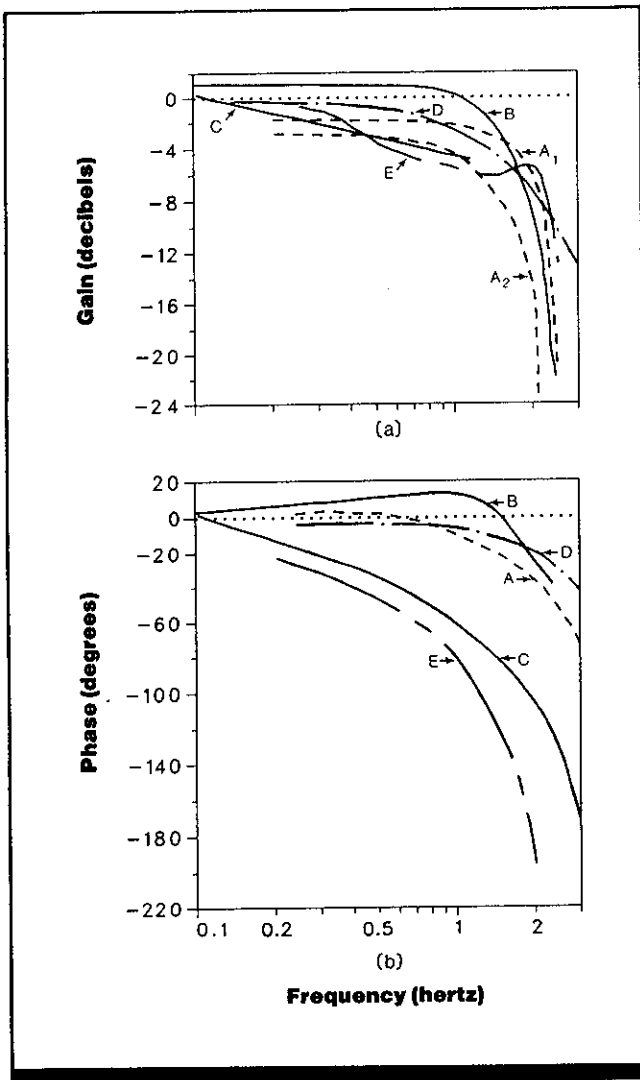

Figure 1. (a) Gain and (b) phase of the oculomotor system for photopic stimuli derived by various authors. A₁ and A₂: single sinusoids of 1.1 and 3.4 deg amplitude, respectively (Ref. 2). B: single sinusoids of 4-10 deg amplitude (Ref. 4). C: sums of 4-9 sinusoids (Ref. 4). D: single sinusoids (Ref. 1). E: band-limited Gaussian random motion (Ref. 1). (From Ref. 3)

Key Terms

Pursuit eye movements; smooth pursuit eye movements; tracking eye movements

General Description

It has been incorrectly assumed that an observer who is tracking a sinusoidally moving target fixates directly on the target and matches target velocity. However, at <1.5 Hz, the gain (eye movement divided by target motion) of the tracking eye movement is <1 and the phase is slightly advanced. Performance begins to deteriorate at $\sim 1-1.5$ Hz

and tracking ceases at 2.5-3.0 Hz. Even highly practiced subjects tracking slow targets have difficulty accurately matching the velocity of the target.

As the dynamic range and spectral content of the stimulus motion are increased (i.e., from lower to higher amplitudes for pure sinusoidal motion, to summing several sinusoidal inputs, and then to Gaussian random motion), gain decreases and phase lag increases.

Applications

Displays and environments requiring visual tracking of moving targets.

Methods

Test Conditions

Study 1 (Ref. 1)

- Observer fixated on a small, bright spot on oscilloscope screen; target movements were unsignalled and were sinusoidal, square-wave, or Gaussian random input (half-power point = 1.25 Hz) patterns
- Amplitude of target motion not given
- Binocular viewing, but only horizontal movements of right eye monitored via light reflection from the iris-scleral border

- Observer's head held stationary by chin and head rests in a dark room

Study 2 (Ref. 2)

- 5-min arc of visual angle square light oscillating horizontally with sinusoidal motion
- Amplitude of target displacement was 1.1, 2.0, or 3.4 deg
- Monocular viewing through left eye; horizontal eye movements tracked via mirror attached to a contact lens

Study 3 (Ref. 4)

- Target was "fairly bright" 0.5 x

- 6.0-cm projected vertical slit that was clearly visible in darkened room; random-step or square-wave input or sum of several sine waves
- Amplitude of target motion not given
- Viewing distance of 185 cm
- Two target motion waveform conditions: predictable and unpredictable
- Observer wore goggles containing peripheral light sources and photocells to measure eye movement
- Binocular viewing, but only horizontal movements of left eye monitored

Experimental Procedure

- Independent variables: target oscillation frequency, waveform of target motion (Ref. 1 and Ref. 4) and amplitude (Ref. 2)
- Dependent variables: gain and phase of tracking eye movements
- Observer's task: visually track target
- 6 young adults with good visual acuity (Ref. 1), 2 observers (Ref. 2) and a few trained observers plus 20 observers on additional related experiments (Ref. 4)

Experimental Results

- As the dynamic range and spectral content of the stimulus motion are increased (i.e., from lower to higher amplitudes for pure sinusoidal motion, to summing several sinusoidal inputs, and then to Gaussian random motion), gain decreases and phase lag increases.
- Tracking performance completely deteriorates at ~2.5-3 Hz.
- If described as a low-pass network, the oculomotor system has a corner frequency of ~1.5 Hz. However, an assumption of linearity is incorrect. For predictable stimuli, phase lags are generally smaller than predicted from the amplitude or gain using the minimum phase condition of servo-

mechanisms. For unpredictable stimuli, gain may increase for the higher frequencies, presumably in an attempt to minimize the faster shifts in retinal image motion that are most deleterious for clear vision (Ref. 3).

Variability

Reference 1 notes that the results are similar for other normal, young-adult observers. For Ref. 2, the gain for one observer was ~3 dB higher than for the other observer with input amplitude of 3.4 deg.

Repeatability/Comparison with Other Studies

Reported results are from several studies.

Constraints

- Data may be valid only for the range of target frequencies and amplitudes studied or for tracking horizontally moving targets.
- Data may be valid under conditions allowing free head movement.

Key References

*1. Dallos, P. J., & Jones, R. W. (1963). Learning behavior of the eye fixation control system. *IEEE Transactions on Automatic Control*, AC-8, 218-227.

*2. Fender, D. H., & Nye, P. W. (1961). An investigation of the mechanisms of eye movement control. *Kybernetik*, 1, 81-88.

3. St-Cyr, G. J., & Fender, D. H. (1969). Nonlinearity of the human oculomotor system: Gain. *Vision Research*, 9, 1235-1246.

*4. Stark, L. Vossius, G., & Young, L. R. (1962). Predictive control of eye tracking movements. *I.R.E. Transaction on Human Factors Engineering*, HFE-3, 52-57.

Cross References

1.904 Methods of measuring eye movements;
9.501 Tactile and visual tracking: Effects of error feedback;

9.528 Pursuit versus compensatory displays;
Handbook of perception and human performance, Ch. 10, Sect. 3.3

1.941 Gain of Tracking Eye Movements: Effects of Target Luminance and Visual Field Location

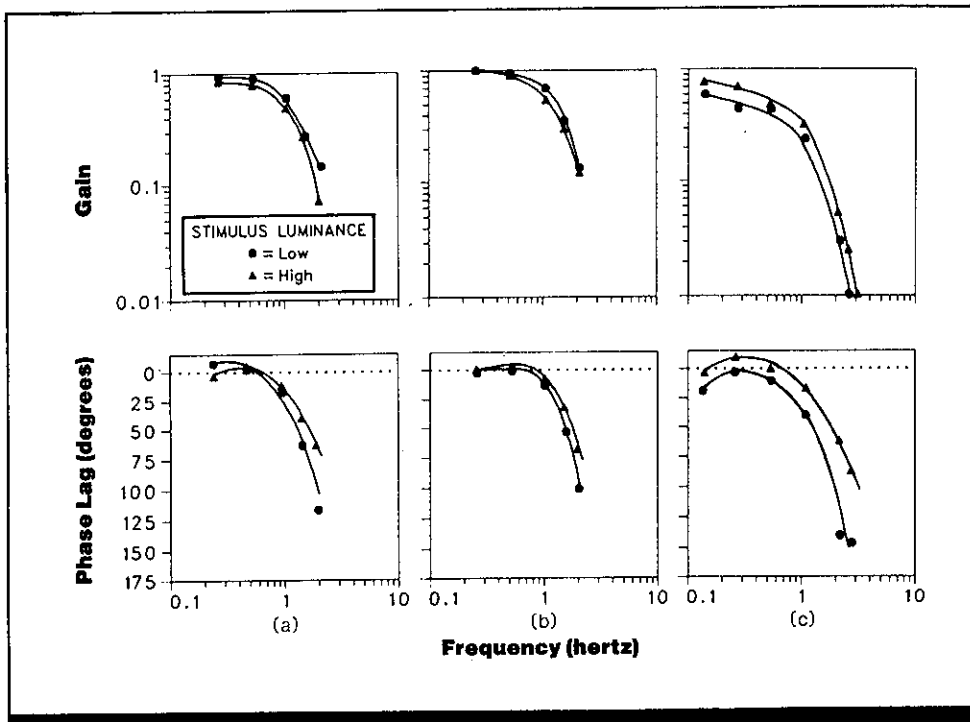

Figure 1. Tracking of predictable sinusoidal motion at high and low stimulus luminance. Phase lag is positive. Task: (a) smooth foveal pursuit without saccades, (b) smooth foveal pursuit with saccades, (c) smooth perifoveal pursuit. (From Ref. 1)

Key Terms

Pursuit eye movements; retinal location; smooth pursuit eye movements; target acquisition; tracking eye movements; visual fixation

General Description

The gain of tracking eye movements is not influenced by target luminance, although the phase lag increases as target luminance decreases. Free saccadic eye movements have little effect on visual tracking. Tracking of targets below the line of sight is easily accomplished without practice.

Applications

Displays and environments that require visual tracking of targets with different luminances and at different visual field locations.

Methods

Test Conditions

- After fixation on red point of light, point target presented via oscilloscope located 1.3 m from subject's right eye (left eye covered) to dark-adapted subject
- Target moved sinusoidally, with

frequencies of 0.13-5.0 Hz and amplitude of 2.18 deg

- For perifoveal targets (5-7 deg below line of sight), target luminance was either high in photopic range (1.85 log units above absolute foveal threshold), appearing as focused green point, or low in scotopic range (0.5 log units above absolute scotopic threshold), appearing as an achromatic blurred mass surrounded by "rayons"

- For foveal (line of sight) targets, luminance was 0.5 or 1.5 log units above absolute foveal threshold
- For foveal target, subject encouraged to smoothly pursue target (CRef. 1.940) or to use saccades as frequently as possible to keep line of sight on target
- Eye movements recorded by infrared contact lens optical lever using infrared

Experimental Procedure

- Independent variables: target luminance, frequency of target motion, visual field location of target, type of eye movement (vertical or horizontal)
- Dependent variables: gain and phase of eye movements
- Subject's task: initiate horizontal target movements for 20 sec when ready
- 2 experienced observers

Experimental Results

- Observers performed well on target tracking for targets 5-7 deg below line of sight.
- Effect of target luminance on gain of smooth-pursuit movements is small and differs for each observer, suggesting that reducing target luminance does not systematically reduce gain.
- Overall smooth-pursuit gain is slightly higher for foveal target than for perifoveal target.
- Smooth-pursuit movements for low-luminance targets slightly lag smooth-pursuit movements for high-luminance targets.
- Both observers show "predictive tracking" of perifoveal

targets, i.e., smooth-pursuit movements lead the target at 0.25 Hz under high luminance for one subject and at ≤ 0.5 Hz under both luminance conditions for the other subject.

- Freely permitting the use of saccades has little effect on gain or phase of pursuit eye movements.
- The above results are consistent with the notion that the observer is responding to an internal model of the stimulus motion that is not luminance-dependent.

Variability

Systematic changes in performance were not observed within or between sessions.

Constraints

- Results may be specific to retinal areas containing cones and may not apply to targets falling on a higher proportion of peripheral retinal areas without cones.
- Results may not be valid for more widely separated lumi-

nance levels, and levels different from those of the present study may produce different effects on tracking.

- Results may not be valid for targets with unpredictable or nonsinusoidal motion.

Key References

*1. Winterson, B. J. & Steinman, R. M. (1978). The effect of luminance on human smooth pursuit of perifoveal and foveal targets. *Vision Research*, 18, 1165-1172.

Cross References

- 1.904 Methods of measuring eye movements;
- 1.915 Effects of target characteristics on eye movements and fixation;
- 1.934 Elicitation of saccades: ef-

fects of target size and proximity to fovea;

- 1.940; Gain and phase of smooth pursuit eye movements: effect of target motion;
- 1.942 Latency and velocity of smooth pursuit eye movements: effect of target velocity;

1.944 Visual tracking of complex sinusoidal motion;

- 5.604 Target localization during pursuit eye movements;
- 5.605 Target localization during pursuit eye movements: effect of intensity of a brief target;

9.501 Tactile and visual tracking: effects of error feedback;

- 9.528 Pursuit versus compensatory displays;
- Handbook of perception and human performance*, Ch. 10, Sect. 3.3

1.942 Latency and Velocity of Smooth Pursuit Eye Movements: Effect of Target Velocity

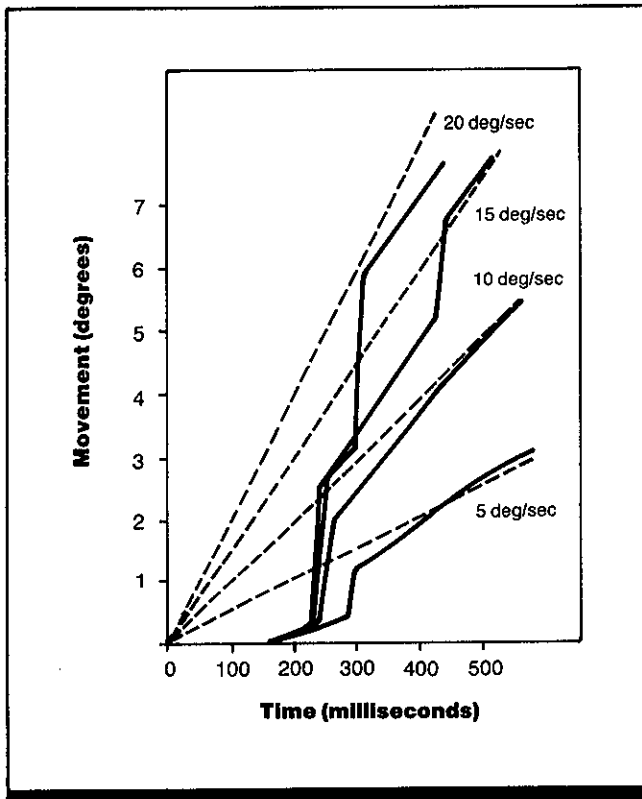

Figure 1. Eye movement responses to ramp target motions of different angular velocities. Broken lines indicate target motion; solid lines represent eye movements. (From Ref. 4)

Key Terms

Pursuit eye movements; saccadic eye movements; smooth pursuit eye movements; tracking eye movements

General Description

When a previously stationary target begins to move horizontally at a constant velocity (ramp target movement), pursuit eye movements lag ~ 130 msec behind target. This initiation latency is unrelated to target velocity in the range of 5-20 deg/sec. This movement also does little to reduce position error (target's distance from fovea). By the time

of the first corrective saccade, pursuit movement is about 6 deg/sec. The saccade becomes larger in amplitude and appears earlier as target velocity increases. After the first corrective saccade, position error is reduced and pursuit movement velocity is greater than target velocity. Pursuit velocity then slackens until the target catches up with eye position.

Applications

Displays or environments where the eye must track moving targets.

Methods

Test Conditions

- Black target dots or lines, 4-30 min arc of visual angle, on luminous background, or vice versa, rear-projected on translucent

screen 0.6 m from observer, who viewed target binocularly

- Unpredictable horizontal target motion beginning at constant velocity of 5-20 deg/sec
- Eye movements tracked by scleral contact lens (CRef. 1.904)

Experimental Procedure

- Independent variable: target velocity
- Dependent variable: time course of eye movement (deg/sec)
- Observer's task: track horizontal movement of target
- 3 adult male observers

Experimental Results

- For ramp target velocities of 5, 10, 15, and 20 deg/sec, the mean latencies for initiation of smooth-pursuit movements are 132, 125, 113, and 142 msec, respectively, suggesting that latency is not a function of target amplitude.
- The saccade appears earlier (at 282, 237, 221, and 224 msec, respectively) with increased target velocity, apparently approaching 200 msec as a lower limit.
- The saccade becomes larger in amplitude (0.74, 1.24, 2.0, and 1.92 deg, respectively) as target velocity increases. However, the correction is never adequate but is appropriate to the target location on retina ~100 msec earlier.
- The abrupt change in smooth-pursuit velocity which accompanies the saccade becomes far greater at high target velocities.
- Smooth-pursuit velocity overshoot is pronounced at 5 deg/sec but has disappeared at 15 deg/sec; at 20 deg/sec, the eye is approaching maximum velocity (Ref. 5).

- The 20 deg/sec target movement elicits a second saccade ~70 msec (range 50-90 msec) after the first.

Variability

Three additional, but less common, eye movement patterns were observed, showing variability in amount of velocity overshoot, occurrence of saccadic component, and amount of abrupt smooth-velocity change accompanying the saccade. No other information on variability was reported.

Repeatability/Comparison with Other Studies

While the latency between an abrupt target movement and the subsequent saccade does vary, the angular velocity of the saccadic movement is remarkably stereotyped (Ref. 3). The 70-msec separation of the two saccades for the 20-deg/sec target is one of a number of exceptions to the well-established intersaccadic refractory period of ~200 msec.

Constraints

- Data may be valid only for unpredictable patterns of target motion, may not be valid for visual fields containing distracting visual components, or may not be valid for accelerating or decelerating target movement.
- Smooth-pursuit movements are easily affected by certain drugs, e.g., barbiturates (Ref. 2), fatigue, and predictability (Ref. 1).

Key References

1. Hallett, P. E. (1986). Eye movements. In K. Boff, L. Kaufman, & J. P. Thomas (Eds.), *Handbook of perception and human performance: Vol. 1. Sensory processes*

and perception. New York: Wiley.

2. Rashbass, C. (1961). The relationship between saccadic and smooth tracking eye movements. *Journal of Physiology*, 159, 326-338.

3. Robinson, D. A. (1964). The mechanics of human saccadic eye movement. *Journal of Physiology*, 174, 245-264.

*4. Robinson, D. A. (1965). The mechanics of human smooth pur-

suit eye movement. *Journal of Physiology*, 180, 569-591.

5. Westheimer, G. (1954). Eye movement responses to a horizontally moving visual stimulus. *AMA Archives of Ophthalmology*, 52, 932-943.

Cross References

1.904 Methods of measuring eye movements;

1.939 Factors affecting smooth pursuit eye movements;

1.940 Gain and phase of smooth pursuit eye movements: effect of target motion;

1.945 Accuracy of tracking eye movements: effect of target velocity;

7.313 Eye fixations and eye movements during display monitoring;

7.318 Markov model for eye transitions during display monitoring

1.943 Visual Tracking of Random One-Dimensional Motion

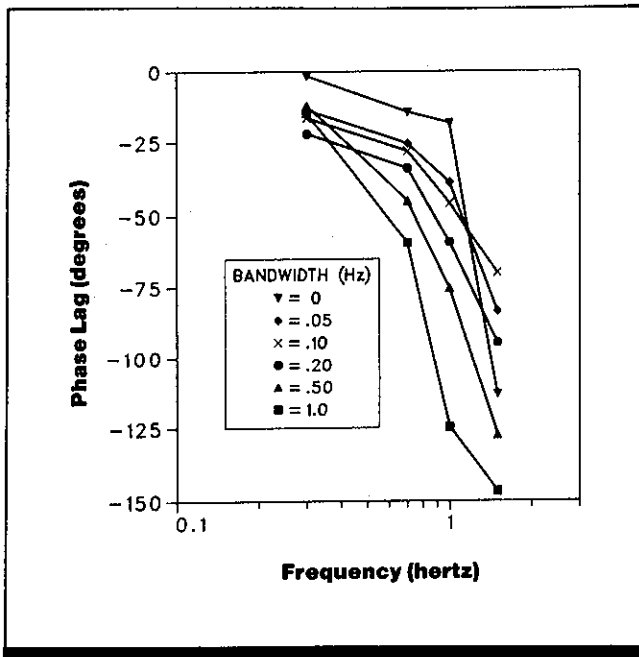

Figure 1. Mean phase shift as a function of center frequency of the stimuli. The six curves represent the responses to signals of six levels of stimulus predictability (six bandwidths in Hz) employed. Minus sign indicates a phase lag. (From Ref. 2)

Key Terms

Smooth pursuit eye movements; target motion; tracking eye movements

General Description

Fixation on a moving visual target is maintained more accurately if the target moves predictably than if it moves unpredictably. For predictably oscillating targets, phase lag of the tracking response is relatively constant at 15-25 deg up to 0.7-1.0 Hz. The cutoff occurs at lower frequencies for more random target movement.

Methods

Test Conditions

- Horizontally moving target produced by magnified oscilloscope trace back-projected on frosted glass screen
- Movement of graded predictability generated from narrow, variable bandwidths of random Gaussian

- noise; bandwidth of 0.0, 0.05, 0.10, 0.20, 0.50, and 1.00 Hz (high to low predictability) centered about 0.3, 0.7, 1.0, and 1.5 Hz
- Mean root mean square angular amplitude was 6.29 ± 1.00 deg for unpredictable stimuli and 10.0 ± 0.4 deg for predictable stimuli

- 24 stimuli presented randomly in single 2.5-hr session; each stimulus presented for 2-3 min with 2-min rest periods
- Observer's head held level and at fixed distance from screen by bite board; reduced ambient lighting in quiet, electrically shielded room
- Eye movements recorded using electro-oculographic technique (CRef. 1.904)

Experimental Procedure

- Independent variables: predictability of target movement, center frequency of target movement
- Dependent variable: phase relationship between target and eye movement responses
- Observer's task: track horizontal movement of target
- 10 observers

Experimental Results

- With 0.3-Hz target movement, phase lag does not vary significantly with predictability, suggesting the great ease of visual tracking at low movement frequencies.
- At 0.7 and 1.0 Hz, phase lag increases progressively as predictability decreases ($p < 0.001$).
- At 1.5 Hz, phase lag also increases progressively as predictability decreases for the most unpredictable targets (0.10-1.0 Hz bandwidths) ($p < 0.001$).
- The relatively high lag at 1.5 Hz with the zero bandwidth stimulus may be due to high angular target movement velocities, while the large lag associated with the 0.05-Hz bandwidth may represent chance variation.

Variability

Phase lag variability across observers was fairly large. Friedman two-way analysis of variance by ranks was used to determine whether the six means at any one frequency were actually drawn from separate populations, and a non-parametric analysis of trends was used to examine the significance of the serial order of the points at any frequency.

Repeatability/Comparison with Other Studies

Despite the novel method of generating unpredictable stimulus movement and larger movement amplitudes than in previous studies, the results are generally consistent with those of other studies (Refs. 1, 3) except for the predictable movement at 1.5 Hz. This discrepancy may be due to greater amplitude of movement in this study.

Constraints

- Data may be valid only for target movement amplitudes in the range of 6.20 ± 1.00 to 10.0 ± 0.4 deg.
- Data may not be valid for visual fields containing distracting visual components.
- Data may not be valid for accelerating or decelerating target motion if free head movement is allowed.

Key References

1. Dallos, P.J., & Jones, R.W. (1963). Learning behaviour of the eye fixation control system. *IEEE Transactions on Automatic Control*, AC-8, 218-227.

*2. Michael, J.A., & Melvill Jones, G. (1966). Dependence of visual tracking capability upon stimulus predictability. *Vision Research*, 6, 707-716.

3. Stark, L., Vossius, G., & Young, L. (1962). Predictive control of eye tracking movements. *I.R.E. Transactions on Human Factors in Electronics*, HFE-3, 52-57.

Cross References

1.904 Methods of measuring eye movements;

1.941 Gain of tracking eye movements: effects of target luminance and visual field location;

1.944 Visual tracking of complex sinusoidal motion;

5.604 Target localization during pursuit eye movements;

9.528 Pursuit versus compensatory displays;

Handbook of perception and human performance, Ch. 10, Sect. 3.3

1.944 Visual Tracking of Complex Sinusoidal Motion

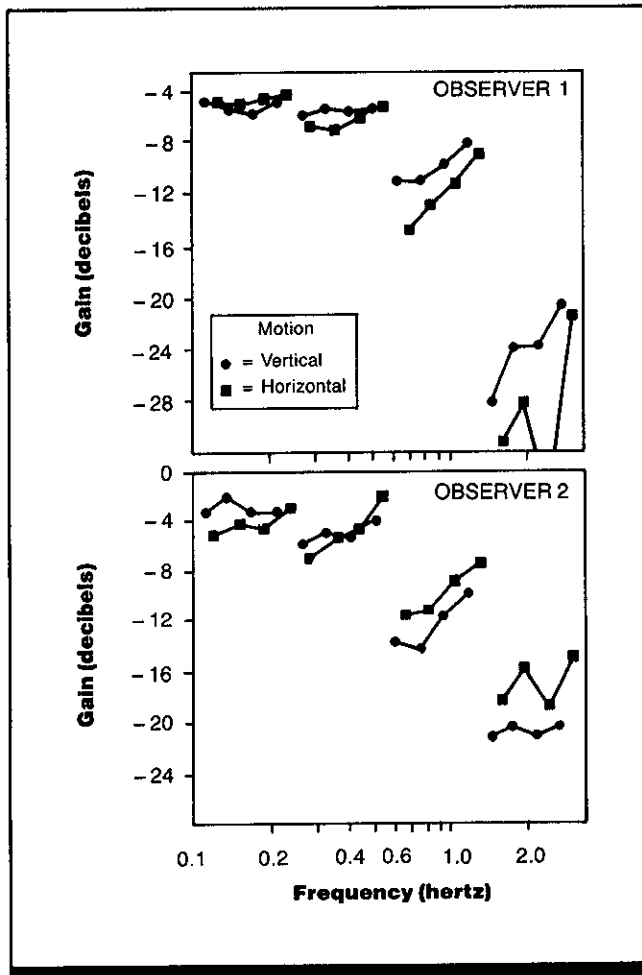

Figure 1. Gain of left eye movements as a function of frequency for 2 observers. Lines join the four frequencies which are members of one band. (From Ref. 3)

Key Terms

Smooth pursuit eye movements; tracking eye movements

General Description

When the eye tracks a spot of light whose motion is a mixture of sinusoids close in frequency, gain of eye movements falls for frequencies $>0.3-0.5$ Hz. However, within each narrow frequency band, the contrary applies; amplitude

rises for higher frequencies. The analysis implies a theoretical minimum delay of eye movements in tracking of ~ 65 msec, corresponding to the minimum transit time between photoreceptors and motor neurons plus a variable delay reflecting the complexity of the motion.

Applications

Displays or environments in which the eye must track targets with complex motion. The increasing gain for higher frequencies within each band suggests an active attempt to minimize the faster shifts of the retinal image that are more deleterious for clear vision, while slower drifts are tolerated.

Methods

Test Conditions

- Target dot 2 min arc of visual angle in diameter presented via oscilloscope 2.63 m in front of observer; dot moved for 116 sec as observer viewed it binocularly

- Dot set in motion with driving function equal to sum of eight non-integrally related sinusoids
- 32 frequencies, 0.1-3.0 Hz, divided into narrow bands of four vertical and four horizontal frequencies each
- Vertical and horizontal movements of both eyes tracked by scleral contact lenses (CRef. 1.904)

Experimental Procedure

- Independent variable: frequency band comprising target waveform
- Dependent variable: gain of visual tracking
- Observer's task: track target closely
- 2 observers

Experimental Results

- Despite subjective randomness of target motion, eye movements consist of only those frequencies present in the stimulus.
- The average gain of eye movements relative to target motion decreases as the average frequency of the band increases.
- Within a given frequency band, gain increases with increasing frequency.
- Tracking movements show a minimum delay of 65 msec, where delay is calculated as the time shift that minimizes the root mean square difference between stimulus and eye motion, plus a variable delay reflecting the complexity of motion (CRef. *Handbook*).
- Results are qualitatively the same for both observers and for both vertical and horizontal eye movements.
- There can be slight cross talk at the muscular or neural

levels, power appearing in the retinal component of eye movement at frequencies that only occur in the horizontal component of stimulus motion, and vice versa.

Variability

No information on variability was given.

Repeatability/Comparison with Other Studies

Eye movement gains found here are lower than those previously reported; however, the literature shows a trend toward lower gain as the complexity of target motion increases from single sinusoids (Refs. 1, 2, 4) to band-limited white noise (Ref. 1). Previous studies used horizontal tracking motions only; the addition of vertical motions may increase the complexity of the task imposed on the oculomotor system.

Constraints

- The specific results obtained may be valid only for foveal tracking tasks.

Key References

1. Dallos, P.J., & Jones, R.W. (1963). Learning behaviour of the eye fixation control system. *IEEE Transactions on Automatic Control*, AC-8, 218-227.

2. Fender, D. H., & Nye, P. W. (1961). An investigation of the mechanisms of eye movement control. *Kybernetik*, 1, 81-88.

*3. St-Cyr, G.J., & Fender, D. H. (1969). Nonlinearities of the human oculomotor system: Gain. *Vision Research*, 9, 1235-1246.

4. Stark, L., Vossius, G., & Young, L. R. (1962). Predictive control of eye tracking movements. *IEEE Transactions on Human Factors Engineering*, HFE-3, 52-57.

Cross References

1.904 Methods of measuring eye movements;

1.940 Gain and phase of smooth pursuit eye movements: effect of target motion;

1.941 Gain of tracking eye movements: effects of target luminance and visual field location;

1.943 Visual tracking of random one-dimensional motion;

9.523 Varying parameters of the crossover model;

9.530 Characteristics of display formatting that influence tracking;

Handbook of perception and human performance, Ch. 10, Sect. 3

1.945 Accuracy of Tracking Eye Movements: Effect of Target Velocity

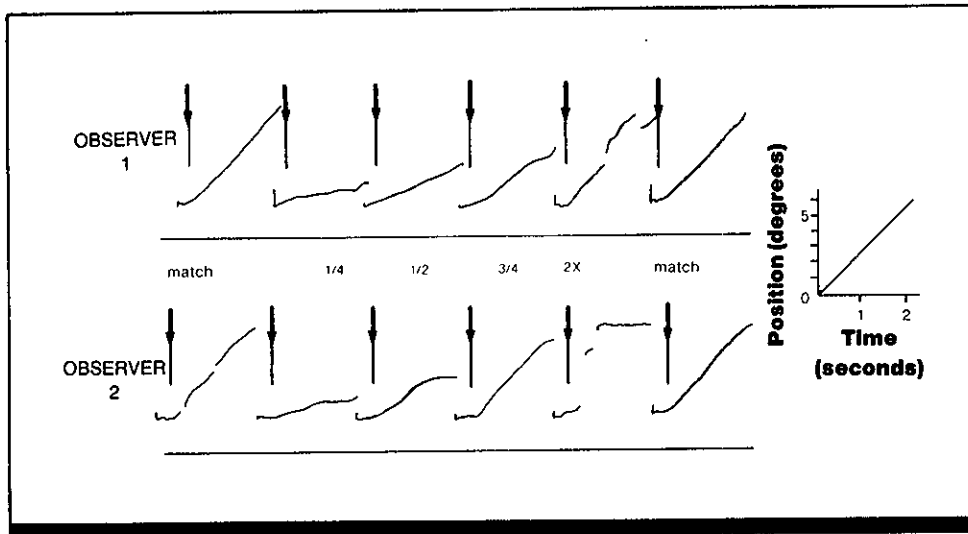

Figure 1. Horizontal eye movement recordings of 2 observers tracking a target moving at 172 min arc of visual angle/sec. The record for each observer shows six consecutive trials run under the following sequence of instructions: first match target velocity, then pursue at 1/4, 1/2, 3/4, 1, and 2 times target velocity, then again attempt to match. Arrows mark time of appearance of moving target. (From Ref. 3)

Key Terms

Pursuit eye movements; smooth pursuit eye movements; target acquisition; visual fixation

General Description

Observers can easily track target motion at reduced eye velocities when asked to track at 1/4, 1/2, or 3/4 target velocity, although actual tracking velocities sometimes depart from those specified. However, when tracking at full target velocity, they cannot accurately match or smoothly exceed target velocity of 0.5-11.00 deg/sec.

Methods

Test Conditions

- Moving target, a sharply focused green point 1.00 log unit above absolute foveal threshold, located 1.0 m from right eye (left eye covered)

- Between trials, observer fixated stationary red point at right side of oscilloscope screen
- Observer initiated trials, bringing target into view at position defined by red intertrial point; target immediately moved left, traveling through angle of 6.0 deg arc of visual angle at velocity of 34, 69, 172, 344, or 687 min arc/sec; target then disappeared

- Target viewed in otherwise dark room

Experimental Procedure

- Eye movements recorded using contact-lens optical lever technique (CRef. 1.904)
- Independent variables: target velocity, desired velocity of pursuit

- Dependent variable: smooth pursuit velocity, defined as mean of intersaccadic pursuit velocities, each weighted according to its duration
- Observer's task: visually track target at 1/4, 1/2, 3/4, 1 or 2 times target velocity
- Two sessions of 60 trials/target velocity; only eye movements in second session recorded
- 2 highly experienced observers

Experimental Results

- Observers exercised voluntary control of smooth-pursuit velocity. Neither observer successfully produced required fraction of target velocity, but both succeeded in altering smooth-pursuit velocity as instructed.
- Voluntary control of smooth pursuit velocity was possible only when observers tried to pursue more slowly than target moved. When asked to go twice as fast as target, observers did go faster but always made saccades.

- Neither observer matched eye to target velocity when asked to do so, averaging only ~80-90% of target velocity.

Variability

No information on variability was given.

Repeatability/Comparison with Other Studies

Reference 1 reports failure to match constant velocity target motion for unpredictable targets. Others (Refs. 2, 4) report accurate matching with unpredictable targets moving at velocities used in present study.

Constraints

- Data may be valid only for highly experienced observers or for horizontally moving targets.
- Data may not be valid for targets moving <34 or >687 min arc/sec or for targets moving through an angle >6.0 deg arc.
- Data may not apply to unpredictable target onset time or movement.

Key References

1. Puckett, J. W., & Steinman, R.M. (1969). Tracking eye movements with and without saccadic corrections. *Vision Research*, 9, 695-703.

2. Rashbass, C. (1961). The relationship between saccadic and smooth tracking eye movements. *Journal of Physiology*, 159, 326-338.

*3. Steinman, R.M., Skavenski, A. A., & Sansbury, R. V. (1969). Voluntary control of smooth pursuit velocity. *Vision Research*, 9, 1167-1171.

4. Westheimer, G. (1954). Eye movement responses to a horizontally moving visual stimulus. *AMA Archives of Ophthalmology*, 52, 932-941.

Cross References

1.904 Methods of measuring eye movements;

1.939 Factors affecting smooth pursuit eye movements;

1.940 Gain and phase of smooth pursuit eye movements: effect of target motion;

1.942 Latency and velocity of smooth pursuit eye movements: effect of target velocity;

1.943 Visual tracking of random one-dimensional motion;

5.604 Target localization during pursuit eye movements;

9.528 Pursuit versus compensatory displays;

Handbook of perception and human performance, Ch. 10, Sect. 3.3

1.946 Accuracy of Tracking Eye Movements: Effects of Target Motion

Key Terms

Active control; corrective saccades; end-primary error; passive control; saccadic eye movements; smooth pursuit eye movements; target acquisition; tracking eye movements; visual fixation

General Description

Observers can visually track moving targets accurately with smooth pursuit eye movements, can monitor the extent of their errors and can correct those errors with secondary saccades. The quality of smooth pursuit tracking by eye improves if the observer actively controls the target's movement. Passive movement of the arm controlling target motion leads to less accurate visual tracking than active movement, but more accurate tracking than when target movement is independent of arm movement.

Applications

Responses to visual tasks will be more accurate when the operator has control of or can successfully predict the locations of a visual target; under these conditions, tracking is smoother and requires fewer corrective saccades.

Methods

Test Conditions

Studies 1, 2 (Ref. 1)

- Binocular viewing of target (spot of light) at 30.5 cm from observer's right cornea; eye movement recorded by measuring infrared light reflected from iris-sclera junction of right eye; arm movement recorded; head held steady via bite board.
- Target moved 3-4 times per sec

Study 3 (Ref. 1)

- Same as for Studies 1 and 2, except stroboscopic (intermittent) presentation of target for 10 msec every 200 msec

Experimental Procedure

Study 1

- Independent variable: active versus passive movement of arm to control position of target, versus target position controlled independently of observer's arm movement
- Dependent variable: relationship between eye and hand movements in active, passive, and independent movement conditions
- Observer's task: to move arm, placed on flat lever pivoting near elbow, such that location of hand provided information about target location and motion (active condition); to rest hand on lever, moved by experimenter such that arm position signalled location of target without active movement by observer (passive condition)

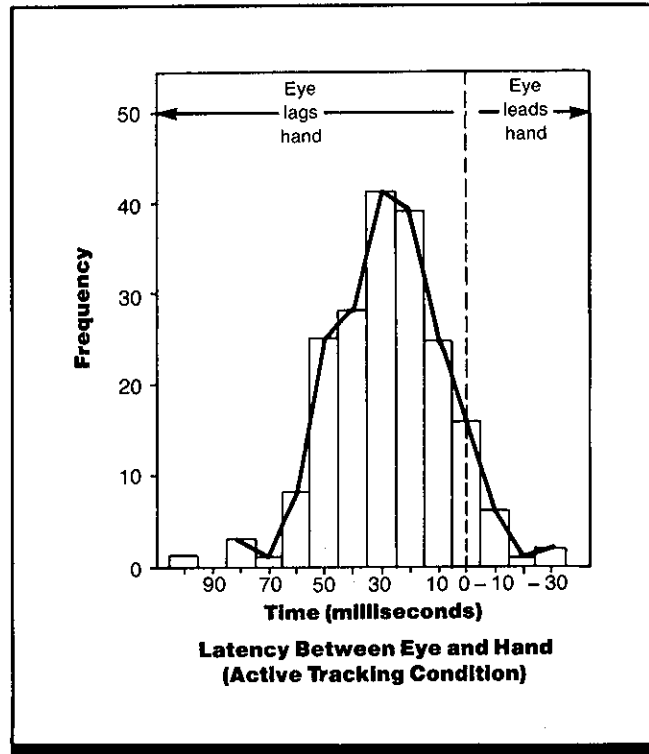

Figure 1. Frequency distribution illustrating the tendency for the observer's eye movements to lag slightly behind the hand movements used to control target position. Average lag is 30 msec and varies considerably across individuals. (From Ref. 1)

- 8 observers: 6 adult males and 2 adult females with no apparent visual abnormalities

Study 2

- Same as for Study 1, except for change in instrumentation, with observer's arm movement signalling motion, but not exact location, of target
- 4 adult male observers

Study 3

- Same as for Study 1, except that for one condition, observer had no contact with apparatus and monitored target without concurrent movement of arm and hand
- 5 adult male observers

Experimental Results

- In all conditions involving continuously present target and observer controlled target movement, eye and hand movements are most closely linked, with small latency differences between movement of hand and eye, and an average of 14.4 saccades in 10 sec of tracking.
- In passive conditions and with continuously present target, the mean number of saccades increases to 24.6 in any 10-sec tracking period; a lag between hand motion and subsequent eye movements appears (Fig. 1).
- When observer has no control over target movement, tracking is minimal (Fig. 2) and eye movements are not re-

lated to target movement; further, tracking only occurs at low rates of target movement.

- With intermittent presentation of the target, observers report the perception of a smoothly moving target in active and passive modes; when the target moves independently of the observer, the spot is seen as flashing on and off with no apparent motion, only a change of location.

Variability

The standard deviation of the difference between number of saccades for active versus passive conditions is 7.43 (Study 2). The standard deviation of the difference between number of saccades for active versus passive conditions is 3.43 (Study 3).

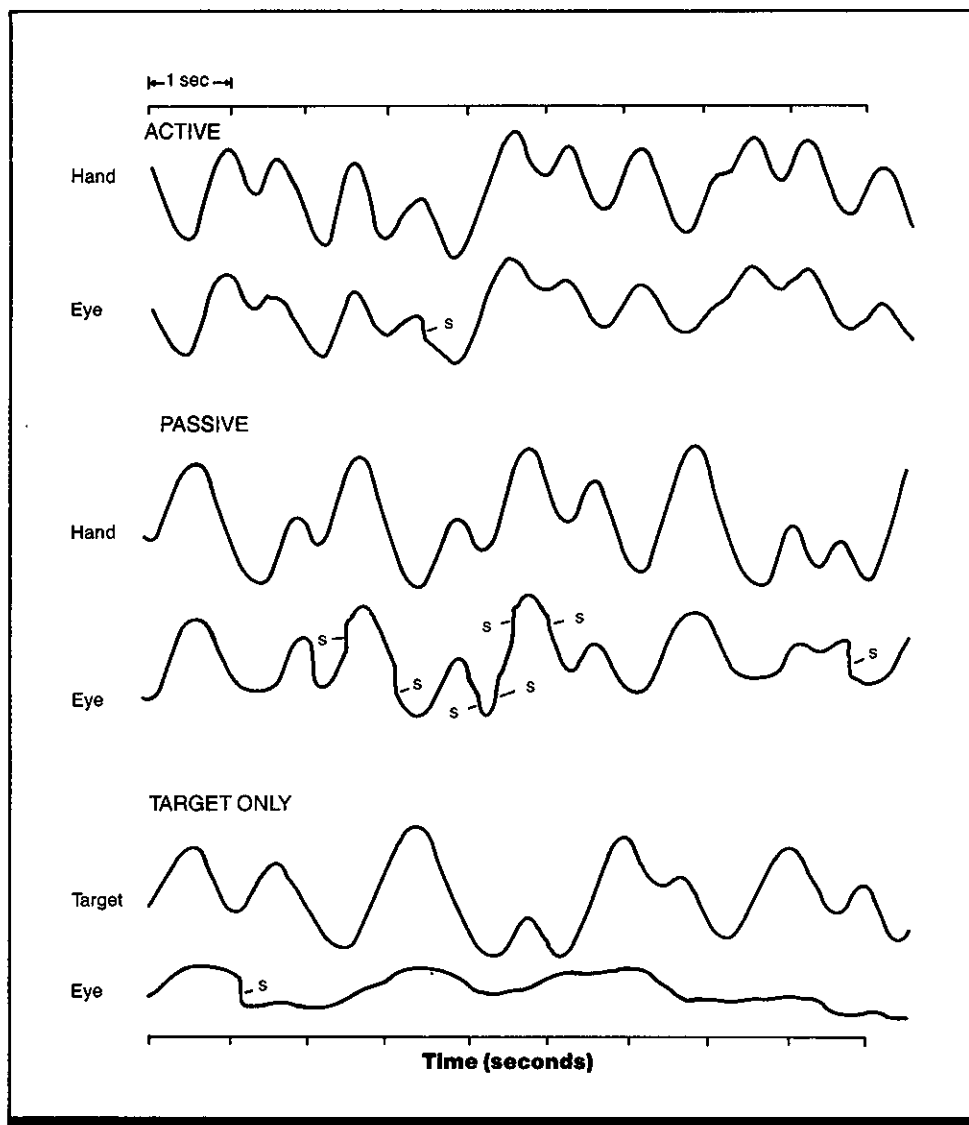

Figure 2. Relationship between hand movement that controls the visual target and subsequent tracking motions of the eye for active and passive conditions and when the target moves independently of the observer (target only condition). In the latter condition, tracking is very poor. For these data, the observer saw the target 10 msec out of 200 msec (5% of the time). The data for active and passive movements of the observer's arm resemble closely the data for continuous presentation of the target. Obvious saccades are marked with the letter s. (From Ref. 1)

Constraints

- Number of saccadic movements may differ by a factor of two (active conditions) or three (passive conditions) from one individual to another.
- When target is on appreciably more than 5% of the time, target motion, not just position change, may be seen when target motion is independent of arm motion.

Key References

*1. Steinbach, M. J. (1969). Eye tracking of self-moved targets: The role of efference. *Journal of Experimental Psychology*, 82, 366-376.

2. Steinbach, M. J., & Held, R. (1968). Eye tracking of observer-generated target movements. *Science*, 161, 187-188.

Cross References

1.910 Control-systems-analysis model of visual and oculomotor functions in retinal image stabilization;

1.940 Gain and phase of smooth pursuit eye movements: effect of target motion;

1.942 Latency and velocity of smooth pursuit eye movements: effect of target velocity;

1.944 Visual tracking of complex sinusoidal motion;

5.604 Target localization during pursuit eye movements;
9.501 Tactile and visual tracking: effects of error feedback;

9.528 Pursuit versus compensatory displays;

Handbook of perception and human performance, Ch. 10, Sect. 3.6

1.947 Visual Tracking: Effects of Perceived Versus Real Target Motion

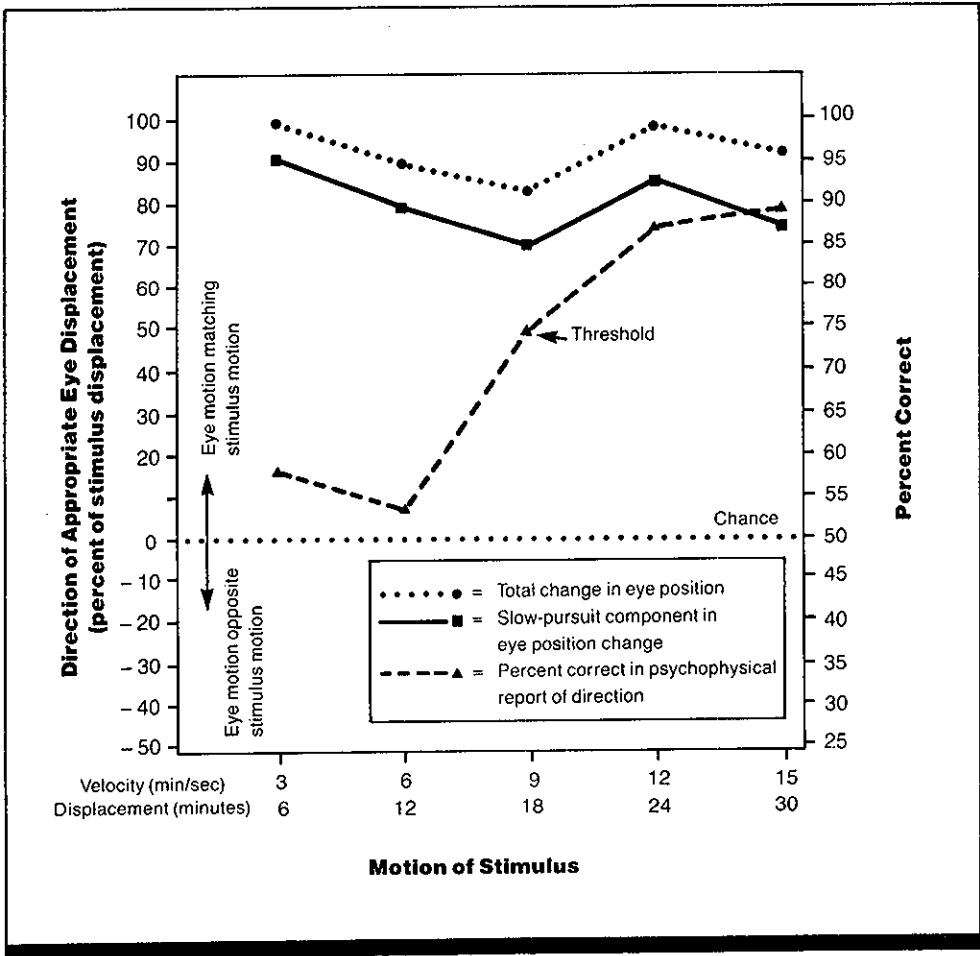

Figure 1. Eye motion and psychophysical report as a function of target velocity. Eye motions are plotted against the left ordinate as a percentage of total target displacement, and psychophysical reports are plotted against the right ordinate. (From Ref. 2)

Key Terms

Eye movements; pursuit eye movements; smooth pursuit eye movements; target motion; tracking eye movements; visual fixation

General Description

Movement of a target image across the retina (i.e., retinal movement) is an adequate stimulus for pursuit eye movements. Perceived target movement is not necessary for initiation of pursuit. When retinal and perceived movements

conflict, horizontal pursuit is controlled primarily by retinal movement if the horizontal components of target movement and perceived movement are in the same direction. If opposite, the path of the eye movement is influenced by the perceived target path.

Methods

Experimental methods are summarized in Table 1.

Experimental Results

Experimental results are summarized in Table 1.

Key References

*1. Holtzman, J. D., Sedgwick, H. A., & Festinger, L. (1978). Interaction of perceptually

monitored and unmonitored efferent commands for smooth pursuit eye movements. *Vision Research*, 18, 1545-1555.

*2. Mack, A., Fendrich, R., & Pleune, J. (1979). Smooth pursuit eye movements: Is perceived motion necessary? *Science*, 203, 1361-1363.

Cross References

1.904 Methods of measuring eye movements;

1.941 Gain of tracking eye movements: effects of target luminance and visual field location;

5.604 Target localization during pursuit eye movements

Table 1. Experimental methods and results.

Study	Methods	Results
Fig. 1 (Ref. 2)	Point of light moved horizontally for 2 sec at 3, 6, 9, 12 or 15 min arc/sec; observer instructed to fixate target and follow with eyes; horizontal eye movements measured by double-Purkinje image eye tracker (CRef. 1.904); observer reported direction of target movement	Accuracy of motion detection increases as target velocity increases; 75% criterion threshold falls just above 9 min/sec The following response of the eye is near optimum at high level for all other velocities Pursuit motion of eyes is not dependent upon perception of motion
Table 2 (Ref. 2)	Target (light spot) motion of 3 min/sec made perceptible by presenting within a surrounding stationary frame of four points marking corners of 0.5 x 3 deg rectangle Target stationary; frame moved horizontally at 3 min/sec for 2 sec, inducing an apparent opposite motion of stationary target	Pursuit behavior of the eye is somewhat better when target motion is perceived than when the target is visible but its motion is not perceived There is only a slight tendency for eye to drift when target is stationary but perceived to be in motion (attributable to 1 of 3 observers)
Fig. 2 (Ref. 1)	Observer tracked spot that moved horizontally in simple harmonic motion; path of second spot moved at angle to first; at signal, observer saccaded to and began to track second spot, which, at the completion of the saccade, was stabilized foveally; this manipulation created a condition of perfect tracking. With left eye occluded, position of right eye measured by double-Purkinje image eye tracker (CRef. 1.904). Perceived path of target is approximated by orientation of its path of motion relative to the horizontally moving spots	Target appears to continue in motion when stabilized on the fovea Eye movements are characterized by decelerating smooth pursuit along a straight path; a turn (~1 deg) at about the time the target would have turned; and acceleration of smooth pursuit after the turn When horizontal motion component of second spot is in the same direction as first spot, tracking continues along what would have been the physical (actual path of the second spot and even reverses appropriately) When the horizontal component of the second spot is opposite that of the first, tracking eventually follows the estimated perceived path of the second spot

Table 2. Mean direction of appropriate eye motions and psychophysical reports. (From Ref. 2)

Condition	Total Eye Movement	Slow Drift	Psychological Reports	
			Correct (%)	Confidence Rating
1	+5.06	+5.17	52	2.125
2	+4.64	+4.55	99	1.08
3	-.8	-.76	99	1.17

In Condition 1, the target is moving at 3 min/sec; in Condition 2, it is moving at the same velocity but is surrounded by a frame to make motion detectable; in Condition 3, apparent target motion is induced in a stationary target. A "+" mark indicates eye motions in the same direction as target motion, and a "-" mark indicates eye motion opposite target motion. The motion data are in minutes of arc; a +6 would indicate perfect following in Conditions 1 and 2, while a 0 would represent perfect following in Condition 3. In the psychophysical report data, the percentages of accurate reports are given for Conditions 1 and 2, and the percentage of induced reports is given for Condition 3. Mean confidence ratings are on a scale of 1 (certainty) to 3 (guess).

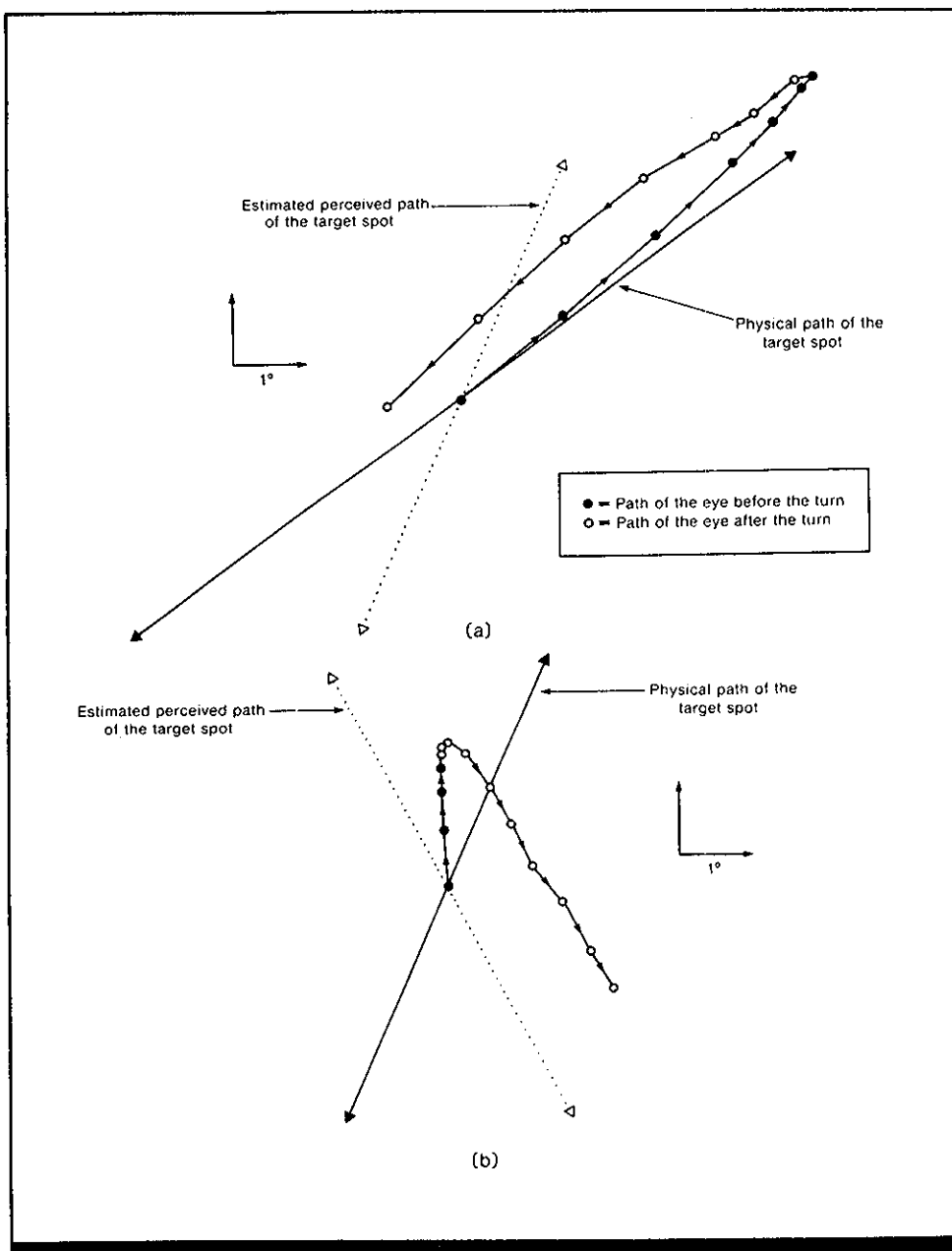

Figure 2. Switch of smooth pursuit from one smoothly moving target to another, showing the path of the eye as the second target is stabilized on the fovea after the saccade. The oblique lines show the physical and estimated perceived paths of the second target, and they are positioned so that their midpoints coincide with the beginning of the eye's path. (a) Horizontal component of second target is in same direction as first target. Tracking continues along what would have been the physical path of second target and even reverses appropriately. (b) Horizontal component of target is opposite to first target. Tracking eventually follows the estimated perceived path of the second target. (From Ref. 1)

Notes

1.948 Involuntary Anticipatory Eye Movements

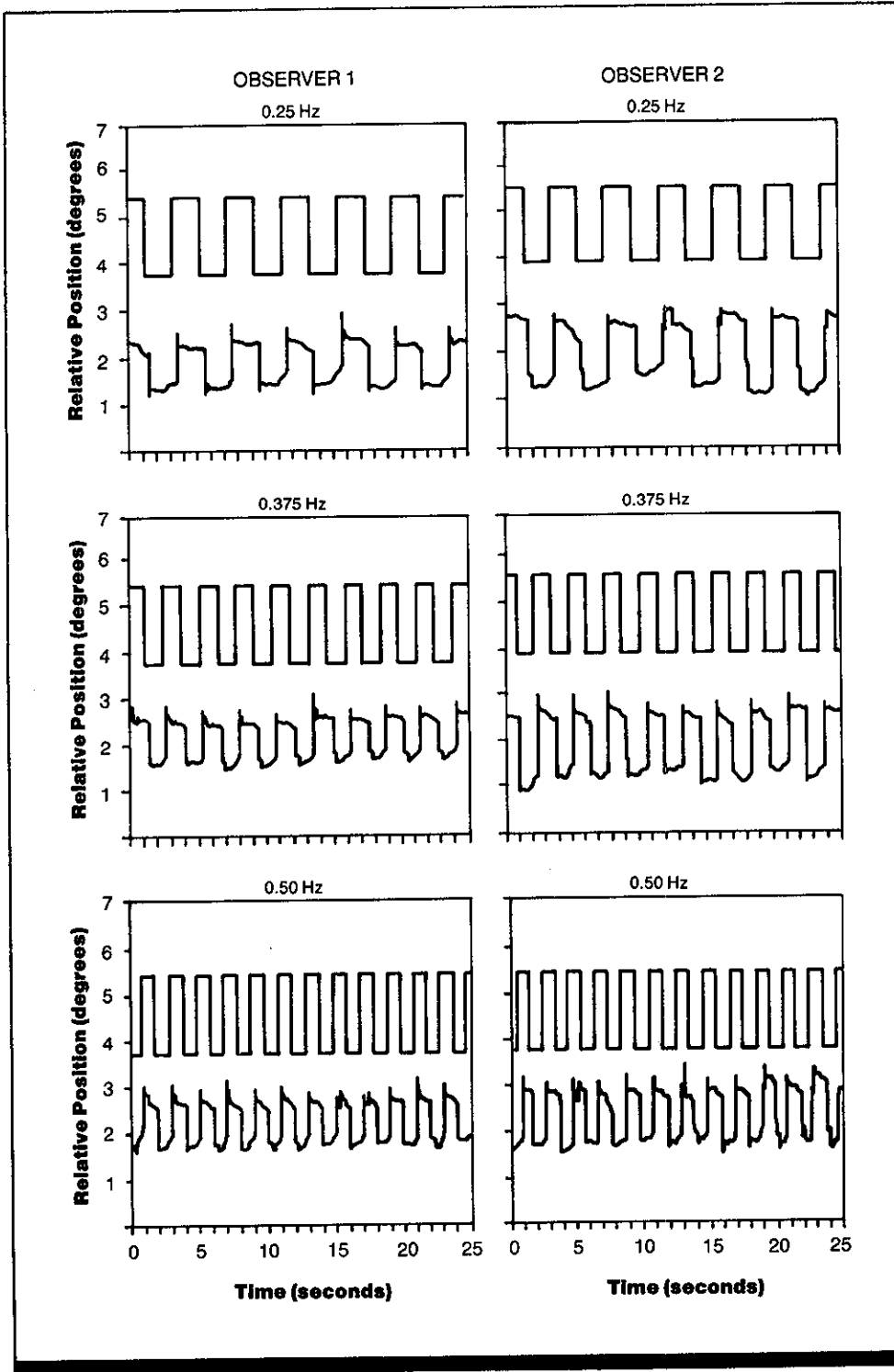

Figure 1. Horizontal anticipatory smooth eye movements (lower traces in each graph) with periodic target steps (top traces in each graph) for 2 experienced observers. Upward displacements of the tracers correlate with movement to the right. (From Ref. 1)

Key Terms

Anticipatory eye movements; target motion

General Description

When observers expect a target to move, their eyes begin to move smoothly away from a stationary point before the target actually moves. This response is involuntary, i.e., it

cannot be suppressed or produced under conditions of no target motion. The effect is robust: it occurs at varying target frequencies, backgrounds, and step sizes. It also occurs with experienced and inexperienced observers.

Methods

Test Conditions

- Stimuli generated in complete darkness on display monitor (P-4 phosphor) located 1.31 m directly in front of observer's eye
- Stimulus was a small point that stepped back and forth through 90 min arc of visual angle along the horizontal meridian, at one of three

frequencies (0.25, 0.375, or 0.50 Hz), i.e., point stepped every 2, 1.33 or 1 sec; point moved either right or left, point's intensity was 1 log unit above threshold

- Only right eye viewed display; left eye was closed and covered; head was stabilized by biteboard
- Beginning 100 msec after observer pressed button, trials lasted 25 sec

- Vertical and horizontal eye movements recorded by a contact lens optical lever; average eye position computed for successive 50-msec intervals

Experimental Procedure

- Repeated measures design
- Independent variables: direction and frequency of target motion
- Dependent variables: direction,

latency, and velocity of eye movements

- Observer's task: make saccades to track each target step, waiting until target stepped before making saccade
- Observers instructed to try to use a single saccade; informed of target direction
- 2 experienced and 3 naive observers

Experimental Results

- Eye drifts in direction of target well before step (target movement) occurs: these anticipatory motions occur on first trial for each observer.
- Anticipatory movements begin about 350 msec before target step, after which velocity increases with time at a relatively constant rate. Velocity is somewhat faster than velocity of slow control movements to maintain line of sight on a stationary point (mean 50-msec velocity for 1 observer, averaged over the three target frequencies, was 15.8 min/sec before rightward steps and 9.9 min/sec before leftward steps; when steps were not expected, mean 50-msec velocity was 0.2 min/sec)
- With vertical stimulus motion, anticipatory smooth eye movements are also vertical.
- These eye movements do not change with practice.
- A richly textured background diminishes, but does not abolish, these eye movements.

- With greater randomization the drift may not be in the direction of the target.

Variability

The range of standard error for velocity of drift eye movements in the expected direction of target motion (for 2 experienced observers) was 0.19-0.24.

Repeatability/Comparison with Other Studies

Several other studies report anticipatory smooth eye movements. Another study by the same authors (Ref. 2) extends these findings by reporting anticipatory smooth eye movements to unperiodic target motion, large target steps in large visual fields, and to unpredictable target directions and times. The latter causes eye movements in a particular idiosyncratic direction.

Constraints

- Voluntary effort reduced, but did not abolish, the anticipatory eye movements in one experienced observer, and did not influence the eye movements of the other. More practice might alter this result.

Key References

*1. Kowler, E., & Steinman, R. (1979a). The effect of expectations on slow oculomotor control-I. Periodic target steps. *Vision Research*, 19, 619-632.

2. Kowler, E., & Steinman, R. (1979b). The effect of expectations on slow oculomotor control-II. Single target displacements. *Vision Research*, 19, 633-644.

Cross References

1.915 Effects of target characteristics on eye movements and fixation;
7.613 Effect of alerted and unalerted search on target acquisition;

9.210 Time and accuracy of fast control movements;
11.401 Guidelines for designing alerting signals;
11.403 Target coding: effect on search time

1.949 Tracking of Targets Oscillating in Depth

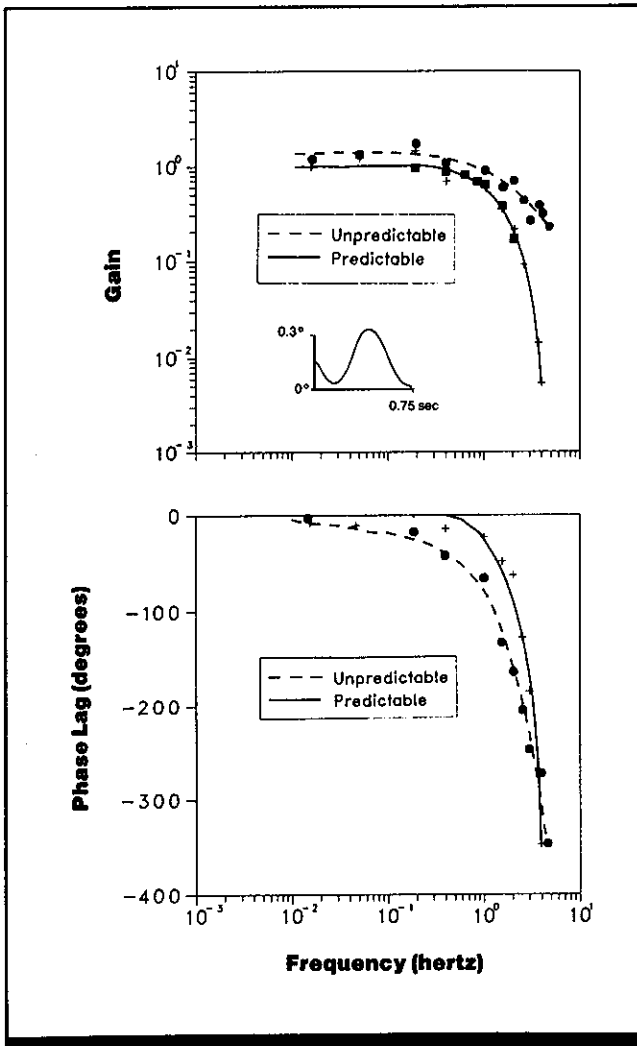

Figure 1. Predictable and unpredictable frequency response of the fusional vergence system. Data averaged over six experiments for 1 observer. Gain is amplitude ratio of vergence eye movement to stimulus disparity. Phase is phase lag of Hering vergence relative to stimulus disparity. (From B. L. Zuber & L. Stark, Dynamical characteristics of the fusional vergence eye-movement system, *IEEE Transaction on Systems, Science, and Cybernetics*, SSC-4. Copyright © 1968 IEEE. Reprinted with permission.)

Key Terms

Binocular viewing; disjunctive eye movements; retinal image disparity; target acquisition; tracking in depth

General Description

If identical but separate targets are presented to each eye, the eyes turn to allow the target images to "fuse" and appear as a single target at a distance corresponding to the intersection of observer's line of sight. Changing retinal

disparity simulates oscillation of the target in depth and invokes slow vergence movements of the eyes up to a frequency of ~ 0.7 Hz. The phase lag for predictable oscillation is significantly less than that for unpredictable oscillation.

Methods

Test Conditions

- Observer viewed faces of two CRTs, one with each eye; small identical spots projected on corresponding positions of the two screens so that the images were fused and observer saw one spot at apparent distance corresponding to the intersection of the two lines of sight

- Stimuli confined to small deviations about an average 6.2 deg of convergence, which corresponds to an apparent distance of ~33.5 cm
- Maximum limit of target excursion was 1.7 deg; observer's head held firmly in position
- Waveform of target movement was predictable (sinusoidal) or unpredictable (a mixture of three sin-

usoids with amplitudes adjusted so that maximum limits of target excursion were 1.7 deg)

- Frequencies of oscillation not specified (generated by Fourier analysis program), but same frequencies used individually and in combination (complex waveform)
- Movements of left eye monitored by light sensors mounted in spectacle frames worn by observer (CRef. 1.904)

Experimental Procedure

- Independent variables: waveform of target movement (predictable or unpredictable), frequency of target oscillation
- Dependent variables: gain, phase of fusional vergence movements
- Observer's task: track visual target
- Number of observers not specified

Experimental Results

- The fusional vergence system gain for unpredictable stimuli is consistently higher than that for predictable stimuli.
- For low-frequency oscillation, up to ~0.7 Hz, the gain for predictable and unpredictable targets is close to unity.
- Unpredictable gain curve appears to fall off more slowly at high frequencies.
- The difference in the two gain curves appears to result from an amplitude-dependent nonlinearity, rather than from the difference in predictability.

- Phase curve obtained in unpredictable stimulation is below that obtained with predictable stimulation.
- The existence in the fusional vergence system of a predictor operator which functions to reduce system phase lag is uncertain, given the nonlinearities.

Variability

No information on variability was given.

Repeatability/Comparison with Other Studies

Fusional vergence responses to sinusoidal oscillations usually die out after a few cycles (Ref. 1). The present observer responded as long as 30 cycles.

Constraints

- Data may not be valid for markedly different target disparities or for more complex target movement.

Key References

1. Rashbass, C., & Westheimer, G. (1961). Disjunctive eye movements. *Journal of Physiology*, 159, 339-360.

*2. Zuber, B. L., & Stark, L. (1968). Dynamical characteristics of the fusional vergence eye-movement system. *IEEE Transactions on Systems, Science, and Cybernetics*, SSC-4, 72-79.

Cross References

1.904 Methods of measuring eye movements;

1.940 Gain and phase of smooth pursuit eye movements: effect of target motion;

1.944 Visual tracking of complex sinusoidal motion;

1.950 Factors affecting vergence eye movements;

1.951 Prolonged convergence of the eyes;

5.904 Functional limits of various depth cues in dynamic visual environments;

5.916 Perceived depth as a function of lateral retinal image disparity

1.950 Factors Affecting Vergence Eye Movements

Key Terms

Binocular viewing; disparity; fusional vergence; stereopsis; three-dimensional displays; vergence eye movements

General Description

Eye movement responses to **retinal image disparity** are often termed fusional vergence because the disparity is reduced to within 0.5 min arc of visual angle, permitting the two images to be fused into a single percept. Target displays

are commonly presented via **stereoscope**; two identical movable targets are presented at a fixed distance, one to each eye. An optical device (e.g., Polaroid, mirrors, baffle) restricts each eye to its own target. The table summarizes several factors that influence vergence eye movements.

Constraints

- Interactions among the various factors may affect vergence movements.

Key References

1. Boltz, R. L., Smith, E. L., III, Bennett, M. J., & Harwerth, R. S. (1980). Vertical fusional vergence ranges of the rhesus monkey. *Vision Research*, 20, 83-85.

2. Duwaer, A. L., & van der Brink, G. (1981). Diplopia thresholds and the initiation of vergence eye-movements. *Vision Research*, 21, 1727-1737.

3. Frisby, J., & Mayhew, J. (1980). The role of spatial frequency tuned channels in vergence

control. *Vision Research*, 20, 727-732.

4. Mitchell, D. E. (1970). Properties of stimuli eliciting vergence eye movements and stereopsis. *Vision Research*, 10, 145-162.

5. Perlmutter, A. L., & Kertesz,

A. E. (1978). Measurement of human vertical fusional response. *Vision Research*, 18, 219-223.

6. Westheimer, G., & Mitchell, D. E. (1969). The sensory stimulus for disjunctive eye movements. *Vision Research*, 9, 749-755.

Cross References

1.951 Prolonged convergence of the eyes;

1.952 Vergence eye movements: eliciting target characteristics;

5.918 Factors affecting stereoacuity;

5.930 Limits of stereoscopic depth perception;

5.931 Stereoscopic depth percep-

tion: limiting differences in left and right half-images;

5.937 Hysteresis effects in stereoscopic vision;

Handbook of perception and human performance, Ch. 10, 23, 35

Factor	Effect on Vergence Eye Movements	References
Horizontal target disparity	Targets seen as single object which may be moved in apparent depth	CRef. <i>Handbook</i>
	Target may appear to enlarge as it apparently recedes	CRef. <i>Handbook</i>
	Typical tolerance for prism-induced disparity: 6 diopter base-in to 22 diopter base-out	Ref. 1
Vertical target disparity	Does not occur naturally for physical objects if head is erect unless there is a vertical phoria (i.e., vertical position of one or both eyes deviates when viewing dissimilar patterns)	
	Correct disparities as small as 0.5 min arc of visual angle	Ref. 2
	Corrects disparities of 0.5-1 deg about eight times more slowly than horizontal disparities	
Target similarity	Left and right eye responses differ in amplitude and dynamics	Ref. 5
	Identical targets elicit vergence movements when horizontal disparity as large as 10 deg	
Exposure duration	Dissimilar targets usually elicit incomplete vergence movements	CRef. <i>Handbook</i>
	Vergence movements elicited with target duration exposure <200 msec	Refs. 4, 6
Half-field onset asynchrony	If one eye occluded after 5 sec, vergence relaxes quickly; if occluded after 60 sec, relaxation is slow and incomplete	CRef. 1.951
	Dissimilar targets elicit vergence movements when presented with an asynchrony of 75-125 msec	Refs. 4, 6
Spatial frequency structure of target	Vergence may be slightly slower at higher spatial frequencies	Ref. 3

Notes

C

C

C

C

1.951 Prolonged Convergence of the Eyes

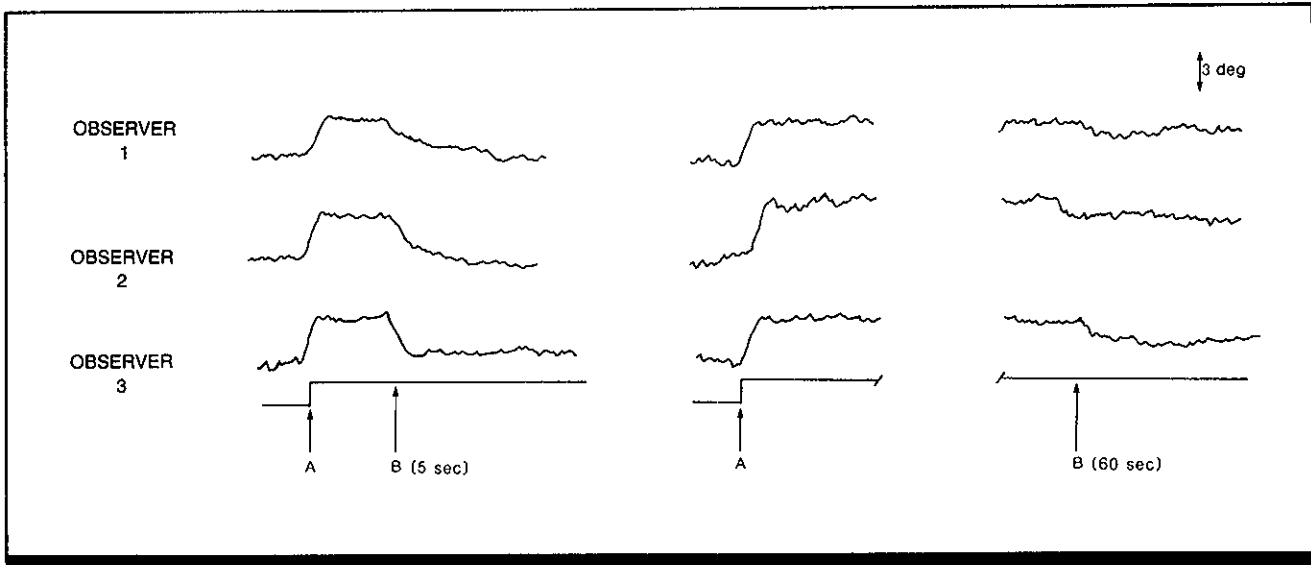

Figure 1. Disparity-induced convergence and its variable relaxation. Left: traces for 3 observers show convergence at onset of 5 sec disparity stimulus at A, and prompt relaxation at B when one eye is occluded. Right: prompt convergence at onset of a 60 sec stimulus, but very slow and incomplete relaxation after the stimulus is withdrawn at B. (From Ref. 5)

Key Terms

Binocular viewing; convergence; depth perception; fixation disparity; retinal image disparity; stereopsis; three-dimensional displays; vergence eye movements

General Description

After 5-sec exposure to retinal image disparity (CRef. 5.905), when one eye is covered, convergence of the eyes is relaxed quickly and completely. After 60-sec exposure,

convergence relaxes slowly and incompletely. This incomplete relaxation of fusional vergence can persist for several hours during monocular occlusion (Ref. 1) or even during sleep (Ref. 2).

Applications

Displays and environments requiring prolonged convergence of the eyes.

Methods

Test Conditions

- Two vertical lines reflected from two front surface mirrors; one line presented to each eye

- Target disparity introduced by displacing, 3 deg to the right, the line presented to the left eye
- Observer maintained vergence response to the disparity for short (5 sec) or long (60 sec) duration, then right eye occluded and observer instructed to continue viewing line placed before left eye

- Vergence eye movements monitored photoelectrically with infrared monitor having resolution limit of 10 min arc of visual angle; vergence movements obtained from the difference signal from the two eyes

Experimental Procedure

- Independent variables: duration of viewing of target lines prior to occlusion of right eye, time after occlusion of right eye
- Dependent variable: convergence of eyes
- Observer's task: fixate on target
- 3 observers

Experimental Results

- After viewing target lines for 5 sec, when one eye is covered, convergence relaxes quickly and completely.
- After viewing target lines for 60 sec, occlusion of one eye is followed by incomplete or no relaxation of convergence.

Variability

No information on variability was given.

Repeatability/Comparison with Other Studies

Several studies report that, when convergence is stimulated briefly, occlusion of one eye is followed by rapid relaxation (e.g., Ref. 2) while relaxation is incomplete following longer convergence times (e.g., Refs. 1, 3).

Constraints

- Data may be valid only for viewing conditions containing no other visual targets.
- Data may not be valid for target disparities other than 3 deg.

Key References

- | | | | |
|---|---|--|---|
| <p>1. Alpern, M. A. (1946). The after effect of lateral duction testing on subsequent phoria measurements. <i>American Journal of Optometry</i>, 23, 442-447.</p> | <p>2. Carter, D. B. (1965). Fixation disparity and heterophoria following prolonged wearing of prisms. <i>American Journal of Optometry</i>, 42, 141-151.</p> | <p>3. Ludvigh, E., McKinnon, P., & Zartzeff, L. (1964). Temporal course of the relaxation of binocular duction (fusion) movements. <i>Archives of Ophthalmology</i>, 71, 389-399.</p> <p>4. Schor, C. M. (1979). The influence of rapid prism adaptation</p> | <p>upon fixation disparity. <i>Vision Research</i>, 19, 757-765.</p> <p>*5. Schor, C.M. (1979). The relationship between fusional vergence eye movements and fixation disparity. <i>Vision Research</i>, 19, 1359-1367.</p> |
|---|---|--|---|

Cross References

- | | | |
|---|---|---|
| <p>1.952 Vergence eye movements: eliciting target characteristics;</p> <p>1.953 Disjunctive eye movements in response to accommodative stimuli;</p> | <p>5.905 Lateral retinal image disparity;</p> <p>5.926 Stereoacuity: effect of exposure duration;</p> | <p>5.931 Stereoscopic depth perception: limiting differences in left and right half-images;</p> <p>5.935 Duration thresholds for stereoscopic targets at different visual field locations</p> |
|---|---|---|

1.952 Vergence Eye Movements: Eliciting Target Characteristics

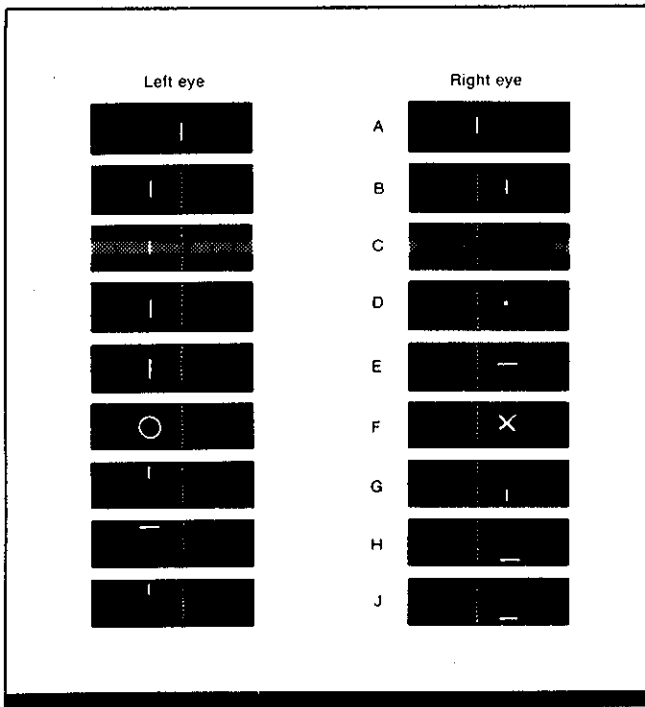

Figure 1. Pairs of sample stimuli used to study horizontal vergence eye movements. A illustrates the targets used to establish foveal positions shown by the white dotted lines. B-J illustrate pairs of stimuli with 2.75-deg horizontal disparity. G-J also display vertical disparity. (From Ref. 2)

Key Terms

Binocular viewing; convergence; depth perception; retinal image disparity; stereoacuity; three-dimensional displays; vergence eye movements

General Description

Vergence eye movements occur when the eyes simultaneously move in opposite directions (convergence or divergence). When identical targets are simultaneously presented, one to each eye, vergence eye movements are trig-

gered if the positions of the targets on the two retinas are disparate; this allows subjective fusion of the two images. Pairs of dissimilar stimuli may elicit incomplete vergence movements.

Applications

Displays and environments requiring binocular fusion of targets.

Methods

Test Conditions

- Observer in darkened room; bite bar used to prevent head movement
- Fixation light 150 cm from front center of observer's body; two 200-msec targets presented in same

frontal plane as fixation point (via slides or oscilloscopes), with one target presented to each eye; fixation light extinguished as targets illuminated

- All depth cues other than disparity were eliminated
- Photoelectric recording of

eye movements (CRef. 1.904), ≥ 5 min arc of visual angle; baseline fovea positions determined at beginning of run with Stimulus A.

Experimental Procedure

- Independent variables: target characteristics (Fig. 1); binasal or

bitemporal presentation (to cause divergent or convergent movement, respectively); vertical disparity; horizontal disparity

- Dependent variable: vergence eye movement
- Observer's task: look at targets
- Number of observers not specified

Experimental Results

- Horizontal disparity: with 0.75-deg vertical lines, response limits for horizontal disparity are 5-10 deg.
- Contrast and luminance: vergence movements are elicited even when one target is dimmed by 1.5 density units (with luminance at moderate photopic levels). Against a uniform background, disparate luminance values for targets (e.g., bright and dark lines) elicit a vergence movement.
- Disparate lengths: vergence movements are elicited by vertical lines when one line is as short as 3 min arc of visual angle and the other line is a different length.
- Shape dissimilarity: targets with different shapes (Fig. 1) and a 2.75-deg horizontal disparity can elicit vergence movements similar to those elicited by vertical lines.

- Vertical disparity: for horizontal disparities from 15 deg, vertical lines 40 min long elicit vergence responses when their centers are vertically separated by ≤ 4 deg.

Variability

There was between-subject variance, but no values were reported.

Repeatability/Comparison with Other Studies

Targets with shorter durations (50 or 100 msec) were sometimes presented with stimulus-onset intervals > 0 ; vergence responses no longer occurred with intervals > 75 -125 msec. Reference 1 demonstrates (1) that vergence response bias may exist within subjects and (2) that shape discrimination may not be a determining factor for directing vergence responses.

Constraints

- Data may be valid only for simple target configurations.
- Data validity unknown for less abstract sensory stimuli or when higher perceptual and memory factors are involved.
- Data validity is unknown when more than one factor (e.g., contrast and shape dissimilarity) varies.

Key References

1. Jones, R., & Kerr, K. E. (1972). Vergence eye movements to pairs of disparity stimuli with shape selection cues. *Vision Research*, 12, 1425-1430.

*2. Westheimer, G., & Mitchell, D. E. (1969). The sensory stimulus for disjunctive eye movements. *Vision Research*, 9, 749-755.

Cross References

1.904 Methods of measuring eye movements;
1.950 Factors affecting vergence eye movements;

1.951 Prolonged convergence of the eyes;
5.905 Lateral retinal image disparity;

5.909 Binocular differences in image size and shape (aniseikonia);
5.912 Tolerance for vertical disparity;
5.918 Factors affecting stereoacuity;

5.927 Stereoacuity: effect of vertical disparity;
5.931 Stereoscopic depth perception: limiting differences in left and right half-images

1.953 Disjunctive Eye Movements in Response to Accommodative Stimuli

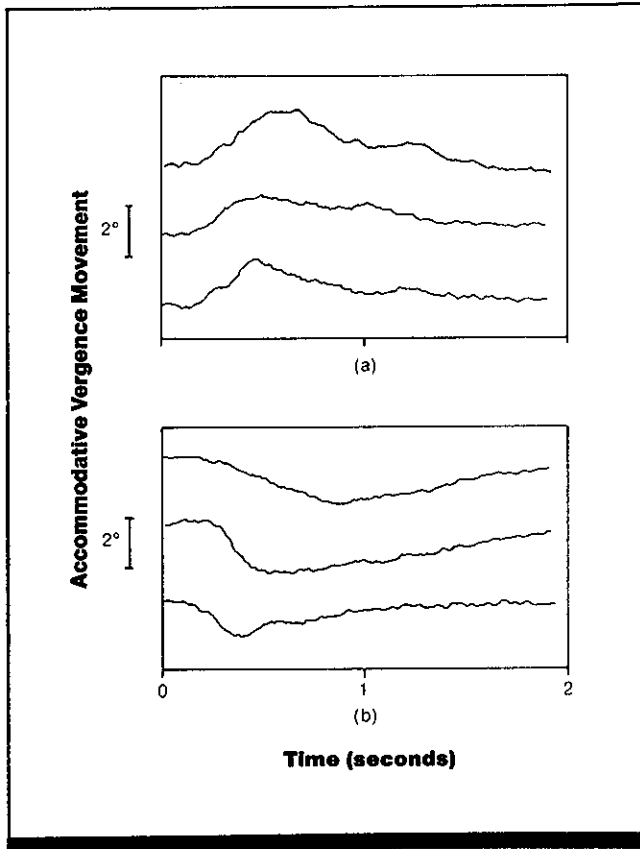

Figure 1. Binocular accommodative vergence. Three pairs of averaged records of night eye position for 3 observers. (a) Transient convergence to optical approach of stimulus from 1-4 diopters at time zero. (b) Transient movement due to optical recession of stimulus from 4-1 diopters at time zero. Optical distance in diopters is reciprocal distance in meters. (From Ref. 2)

Key Terms

Accommodation; binocular viewing; depth perception; disjunctive eye movements; retinal image disparity; three-dimensional displays; vergence eye movements

General Description

When optical distance, but not **retinal image disparity**, of a target is suddenly changed, the optical blur due to incorrect focus stimulates changes in lens shape (focus) and

vergence eye movements. However, this response is transient because the accommodative vergence causes greater **retinal image disparity**, which, in turn, elicits disparity-reducing vergence.

Applications

Displays requiring fixation on receding or approaching targets.

Methods**Test Conditions**

- In dark room, observers viewed target binocularly with symmetrical disparity-vergence stimulation to each eye; increasing and decreasing

step changes in accommodative stimulation (optical distance) presented while disparity vergence was constant

- Target consisted of a 1-deg red circle against a dark background with a small (6 min arc of visual angle) central spot to localize fixation and two small fixation spots

placed 2 deg apart for eye movement calibration

- Targets presented via a dynamic binocular stimulator (see Ref. 1)
- Vergence movements of right eye dynamically measured using differential infrared reflection technique (CRef. 1.904)

Experimental Procedure

- Independent variable: increasing and decreasing changes in accommodative stimulation (optical distance)
- Dependent variable: vergence movements of the right eye
- Observer's task: visually fixate on target
- 3 observers

Experimental Results

- Small vergence movement occurs after a brief delay followed by a return to the original vergence level.
- Return movement occurs 200-300 msec after the initial movement, bringing the eye to the correct, error-free vergence position in another 500-800 msec, a total of 700-1100 msec after the initial movement.
- Direction of initial movement is the same as the direction of the accommodative vergence movement which would have been produced if the target had been viewed

monocularly, although the velocity of binocular accommodative vergence is only half the velocity in the monocular situation.

Variability

No information on variability was given.

Repeatability/Comparison with Other Studies

Earlier attempts to detect vergence eye movements with binocular accommodative stimulation were unsuccessful, possibly because peripheral visual cues are used by observers as alternate targets to stabilize fusion and override any accommodative influence.

Constraints

- The obtained data may not be valid when there are peripheral visual cues, or when targets differ in retinal location, or when targets are larger.

Key References

1. Semmlow, J. L., & Tinor, T. (1978). Accommodative convergence response to off-foveal retinal images. *Journal of the Optical Society of America*, 68, 1497-1501.

*2. Semmlow, J., & Venkiteswaran, N. (1976). Dynamic accommodative vergence components in binocular vision. *Vision Research*, 16, 403-410.

Cross References

1.904 Methods of measuring eye movements;
1.949 Tracking of targets oscillating in depth;

1.950 Factors affecting vergence eye movements;
1.952 Vergence eye movements: eliciting target characteristics;
1.954 Disjunctive eye movements

in response to peripheral image disparity;

5.905 Lateral retinal image disparity;
5.911 Limits of single vision;
5.918 Factors affecting stereoacuity;

5.927 Stereoacuity: effect of vertical disparity;
5.928 Response time and accuracy of depth judgments: effect of vertical disparity

1.954 Disjunctive Eye Movements in Response to Peripheral Image Disparity

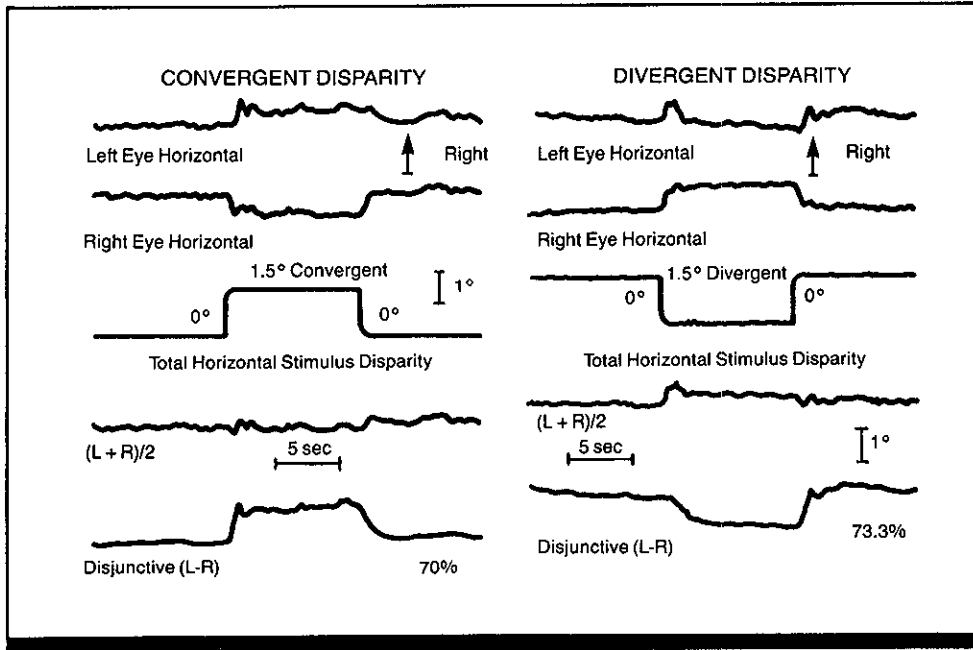

Figure 1: Average of ten fusional responses to a 1.5-deg horizontal convergent or divergent step disparity presentation to 1 observer. The 10-deg diameter blanked central area was stabilized on the left retina. The percentage of the disparity compensated is provided at the right of each panel. (From Ref. 1)

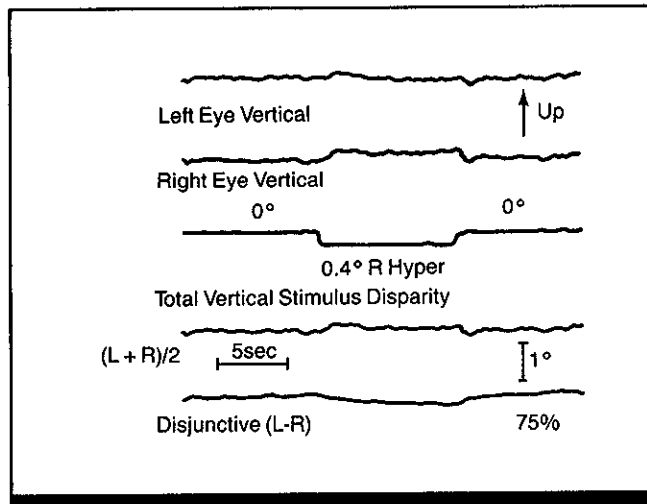

Figure 2. Average of ten fusional responses to a 0.4-deg vertical, right-hyper step disparity presentation to 1 observer. The 10-deg diameter blanked central area was stabilized on the left retina. The percentage of the disparity compensated is provided on the right. (From Ref. 1)

Key Terms

Binocular viewing; disjunctive eye movements; retinal image disparity; three-dimensional displays; vergence eye movements

General Description

Horizontal and vertical disparities in the peripheral retina are sufficient to evoke vergence eye movements to reduce the **retinal image disparity**. The two eyes typically respond asymmetrically and often show faster and slower components.

Methods

Test Conditions

- Wearing scleral contact lens, observer seated in dark room, head held stationary by bite board and headrest
- Targets were circular disks subtending 57 deg, composed of 11 equally spaced parallel horizontal or vertical lines

- Target presented to left eye contained central fixation point, while the central 10 deg of right eye target was electronically blanked; blanked region stabilized with respect to retinal position
- Nature of target disparity was either 1.5 deg horizontal (convergent or divergent) or 0.4 deg vertical

- Targets displayed on oscilloscope with luminance level in mesopic range (3.2 cd/m²)
- 10-sec presentation of zero disparity target, followed by 10-sec presentation of targets displaced an equal amount, but in opposite direction, after which disparity eliminated for 10 sec
- Eye movements recorded using contact-lens optical lever (CRef. 1.904)

Experimental Procedure

- Independent variable: nature of disparity
- Dependent variables: horizontal, vertical eye positions
- Observer's task: gaze (fixate) at center of targets
- 2 stereo-normal observers, vision corrected to 20/20 acuity

Experimental Results

- Following the introduction of horizontal disparity in the peripheral retina, both eyes move in the direction required to decrease the disparity and compensate for 40-77% of the disparity. However, the two eyes respond asymmetrically.
- In all cases, vertical disparity of 0.4 deg elicits a disjunctive motor response that compensates for 75% of the disparity. The eye whose retinal image contains the electronically

blanked central area experiences no net change in eye position, whereas the other eye moves by 0.3 deg.

Variability

No information on variability was given.

Repeatability/Comparison with Other Studies

Torsional disparities in periphery of retinas evoke a fusional response. Present results demonstrate that peripheral horizontal or vertical disparities also elicit a fusional response.

Constraints

- Data may be valid only for specific disparities tested.
- Data may not be valid for more peripheral retinal disparities.

Key References

*1. Kertesz, A. E., & Hampton, D. R. (1981). Fusional response to extrafoveal stimulation. *Investigative Ophthalmology and Visual Science*, 21, 600-605.

Cross References

1.904 Methods of measuring eye movements;
1.949 Tracking of targets oscillating in depth;
1.950 Factors affecting vergence eye movements;

1.952 Vergence eye movements: eliciting target characteristics;
1.953 Disjunctive eye movements in response to accommodative stimuli;
5.918 Factors affecting stereo-acuity

1.955 Fusional Eye Movements in Response to Vertical Disparity

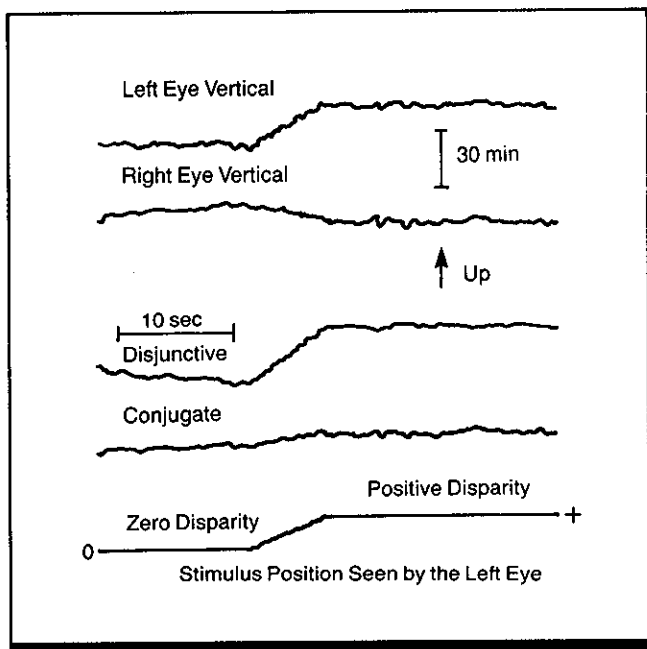

Figure 1. Eye movement responses of 1 observer to the presentation of a vertical disparity whose maximum positive disparity was 33.6 min. (From Ref. 3)

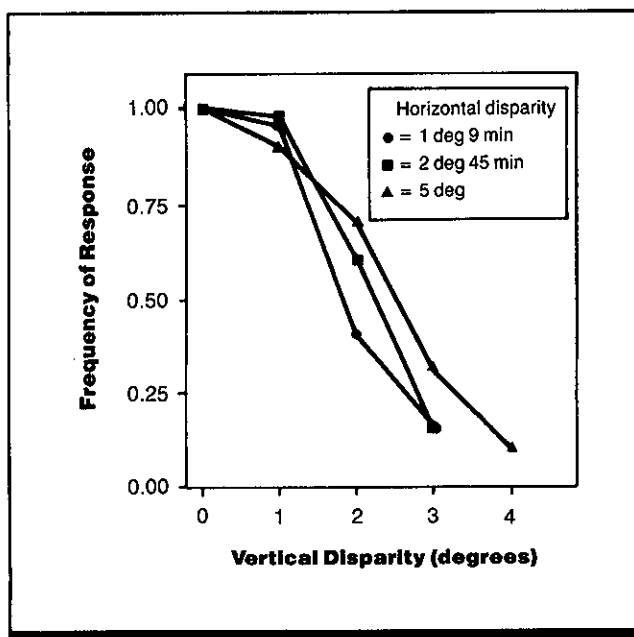

Figure 2. Frequency of horizontal vergence eye movement responses to 200-msec presentations of horizontal vergence targets as a function of the vertical separation (in angular measure) of the targets presented to the two eyes, for 1 observer. The targets were vertical lines subtending 40 min in length. (From Ref. 2)

Key Terms

Binocular viewing; disjunctive eye movements; double vision; fusional vergence; retinal image disparity; three-dimensional displays; vergence eye movements; vertical retinal image disparity

General Description

The mechanism to correct for vertical disparity in the central 4 deg of the visual field is quite sensitive, since vertical disparities as small as 0.5 min arc of visual angle are corrected by fusional eye movements. Vertical disparities of 0.5-1 deg between horizontal lines are corrected eight times

more slowly than similar horizontal disparities between vertical lines. Horizontal disparities do not trigger convergence eye movements if vertical disparities exceed 2-4 deg. Uncorrected or slowly corrected disparity may result in **diplopia** (CRef. *Handbook*).

Methods

Test Conditions

- Observer initially looked at fixation point
- Targets were binocularly-presented lines with horizontal or vertical disparity
- Targets presented via electronic stereoscope (background = 15 deg

in diameter at 3 cd/m²) (Ref. 1) or in darkened room via oscilloscope (Refs. 2, 3)

- Fixation point replaced by disparate dichoptic targets, leading to fusional eye movements

Experimental Procedure

- Independent variables: direction of disparity (horizontal or vertical), amount of disparity

- Dependent variable: latency of fusional eye movement
- Observer's task: move eye to target and indicate if one or two lines were perceived
- Observers instructed to fixate center of stimulus and not scan the pattern
- 3 observers, with correcting lens

Experimental Results

- Vergence eye movements are initiated by vertical disparities that are too small to induce diplopia (0.5 min arc).
- Vertical disparities are corrected eight times more slowly than similar horizontal disparities.

- Horizontal disparities of 1.5 deg are readily fused, but the maximum fusible vertical disparity is <1 deg
- With vertical disparities exceeding 2-4 deg, horizontal vergence responses cease completely.

Variability

No information on variability was given.

Constraints

- Data may not be valid for larger targets or for all retinal positions.
- Data may be valid only for straight line targets.

Key References

1. Duwaer, A. L., & Van den Brink, G. (1981). Diplopia thresholds and the initiation of vergence eye-movements. *Vision Research*, 21, 1727-1737.

*2. Mitchell, D. E. (1970). Properties of stimuli eliciting vergence eye movements and stereopsis. *Vision Research*, 10, 145-162.

*3. Perlmutter, A. L., & Kertesz, A. E. (1978). Measurement of human vertical fusional response. *Vision Research*, 18, 219-223.

Cross References

5.906 Vertical retinal image disparity;

5.910 The horopter: locus of points with no retinal image disparity;

5.911 Limits of single vision;

5.918 Factors affecting stereoacuity;

5.927 Stereoacuity: effect of vertical disparity;

5.928 Response time and accuracy of depth judgments: effect of vertical disparity;

5.930 Limits of stereoscopic depth perception;

5.931 Stereoscopic depth perception: limiting differences in left and right half-images;

Handbook of perception and human performance, Ch. 23, Sect. 5.2

1.956 Eye Torsion: Effects of Angular Disparity in Binocular Display Patterns

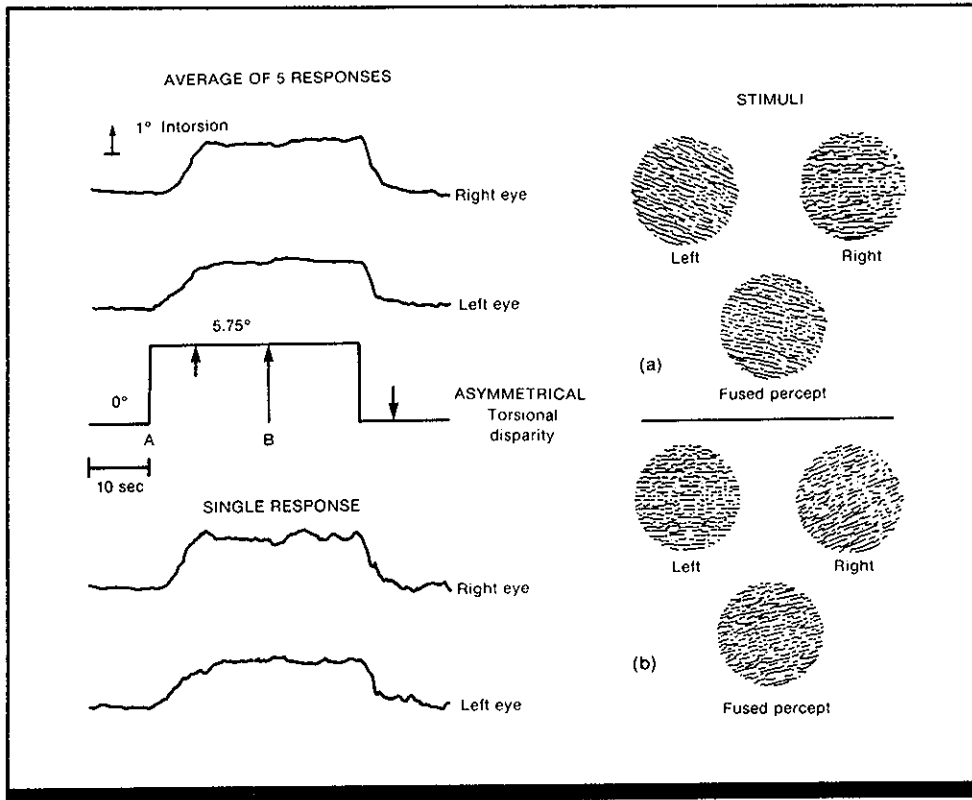

Figure 1. Torsional eye movements in response to asymmetrically tilted patterns. Left: Observer initially views horizontal patterns. At time A, there is a step roll of the left pattern, which is partially compensated by binocular intorsion (i.e., from observer's frame of reference, the left eye rolls clockwise and the right eye rolls counterclockwise). The fused percept develops toward the end of the torsional eye movement (indicated by the small arrow). Switching the patterns at some later time B, without altering the tilt disparity, changes the percept, but does not affect eye position. Right: The patterns presented to the left and right eyes at times A and B (respectively, the upper and lower patterns), and the corresponding fused percepts. (From Ref. 4)

Key Terms

Binocular viewing; cyclofusional eye movements; cyclorotation; fusion vergence; Hering's law of equal innervation; peripheral vision; retinal image disparity; three-dimensional displays; vergence eye movements; visual fixation

General Description

When differentially tilted visual patterns are presented separately to both the right and left eyes, each eye exhibits a corresponding distinct clockwise or counterclockwise rotation (optic torsion response) to minimize the angular disparity between target images in the two eyes and to facilitate the perception of a single, "fused" visual target. When either eye alone is presented with a tilted visual pattern, and an untilted pattern is presented to the other eye, only the eye

presented with the tilted display exhibits movement. If the tilt is then instantaneously reversed while the relative direction of tilt is held constant (i.e., a visual pattern with equal but opposite tilt is presented to the eye previously presented with the untilted pattern, and conversely), then no subsequent contingent eye movement is observed in either eye. The magnitude of such torsional eye movements is somewhat less than that required to compensate completely for the disparate tilt, even when the target appears fused.

Applications

Displays requiring binocular observation of visual patterns exhibiting tilt disparity relative to the vertical.

Methods

Test Conditions

- Pairs of circular discs enclosing disparately-tilted patterns of randomly segmented lines; visual displays presented at optical infinity; discs briefly projected; central fixation point 0.3 deg in diameter
- Head position unspecified but probably upright; head constrained by bite plate and forehead rest
- Field of view limited to 50 deg of

visual angle; luminance 34 cd/m² in dark room; visual pattern discs 10, 30, or 50 deg in diameter

- Pattern discs rotated clockwise or counterclockwise to produce tilt values of 2 or 5.75 deg, or continuous range from 0-10 deg with increments of 0.25 deg added every 62.5 msec; visual tilt symmetric (targets to both eyes tilted inward or outward) or asymmetric (visual display to only one eye tilted, while other remained horizontal)

- Eye movements unrestricted; movements of both eyes continuously recorded and monitored by stabilized magnetic coil contact lenses (Ref. 3) with resolution of 1 min arc and range of ± 5 deg of rotation; contact lenses corrected for refraction
- Four to ten trials per data point; 45-65-sec trials

- Independent variables: tilt magnitude, tilt direction, nature of tilt symmetry, visual display diameter (Ref. 5)
- Dependent variables: direction, amplitude, velocity of eye movements
- Observer's task: judge when randomly segmented lines in visual patterns appeared simultaneously unified, single, and straight (criterion for fusion)
- 1 highly experienced observer, screened for "normal" stereopsis

Experimental Procedure

- Method of limits

Experimental Results

- Binocular viewing of patterns tilted equally, but oppositely, for each eye causes torsional eye movements similar in amplitude and initial velocity, although they compensate for only 48-75% of the total tilt disparity present (and central visual mechanisms compensate for the remainder).
- During an asymmetric tilt of the visual display, the left and right eyes generally exhibit intorsions (rotations toward the midpoint between the eyes) and extorsions (rotations away from the midpoint) of similar amplitude and initial velocity.
- During symmetric tilt disparity, the intorsions of both eyes are of similar duration and amplitude.
- During asymmetric tilt disparity, both the right and left eyes exhibit intorsions and extorsions with similar time courses.
- If a target with asymmetric tilt disparity appears fused, then the perception of fusion is retained when the direction

of tilt disparity is instantaneously reversed. No further torsional eye movements are necessary to maintain fusion.

- Torsional eye movements in response to disparately tilted visual displays exhibit greater latency and slower velocity than those typically found in the case of other vergent eye movements.
- No clear trend is apparent between display diameter and amplitude of eye intorsion (Ref. 5).

Variability

Although eye movement responses on single trials are "noisier" than averaged responses, their shapes are similar in all other respects.

Repeatability/Comparison with Other Studies

Other investigators report comparable results with identical patterns (Refs. 2, 5) as well as with visual displays featuring highly stylized human facial contours and single and multiple horizontal or vertical straight line contours (Ref. 1) and more complex annular patterns (Ref. 5).

Constraints

Only one observer was used so that generalization of numerical values to other observers is hazardous.

Key References

1. Crone, R. A., & Everhard-Halm, Y. (1975). Optically induced eye torsion. I. Fusional cyclovergence. *Albrecht von Graefes Archiv fur Klinische und Experimentelle Ophthalmologie*, 195, 231-239.

2. Kertesz, A. E., & Sullivan, M. J. (1978). The effects of stimuli size on human cyclofusional response. *Vision Research*, 18, 567-571.

3. Robinson, D. A. (1963). A method of measuring eye move-

ment using a scleral search coil in a magnetic field. *IEEE Transactions in Biomedical Electronics, BME-10*, 137-145.

*4. Sullivan, M. J., & Kertesz, A. E. (1978). Binocular coordination of torsional eye movements

in cyclofusional response. *Vision Research*, 18, 943-949.

5. Sullivan, M. J., & Kertesz, A. E. (1979). Peripheral stimulation and human cyclofusional response. *Investigative Ophthalmology and Visual Science*, 18, 1287-1291.

Cross References

1.950 Factors affecting vergence eye movements;

1.952 Vergence eye movements: eliciting target characteristics;

1.957 Factors affecting counter-torsion of the eyes;

5.908 Retinal image disparity due to image rotation in one eye;

5.911 Limits of single vision;

5.931 Stereoscopic depth perception: limiting differences in left and right half-images

1.957 Factors Affecting Countertorsion of the Eyes

Key Terms

Countertorsion; gravitational effects; head tilt; nystagmus; otoliths; torsional eye movements; utricles; vestibular function

General Description

The ocular countertorsion reflex is the tendency of the eyes to remain upright relative to gravity when the head is rotated about an axis parallel to the visual axis. In man, the amplitude of countertorsion is only ~10% of the angle of head tilt.

Factor	Effect (Direction/Magnitude)	Inference/Constraint	References
Gravitational force	Amplitude of countertorsion is greater for gravitational forces $> 980 \text{ cm/sec}^2$	Demonstrates role of otolith organs	Ref. 7
Angle of head tilt	Amplitude of response is a function of the sine of the angle of head tilt	Suggests that countertorsion is induced by shear force on utricles	Ref. 7
Supine posture	Response is absent when head is tilted toward shoulder	Utricles do not respond in this posture and there is no cervico-ocular reflex	Ref. 8
Duration	Amplitude is not reduced for head held tilted for several hours	Suggests reflex is driven by non-adapting utricle receptors	Ref. 4
illumination	The countertorsion response is fairly smooth in darkness, with occasional nystagmic beat There are more prominent nystagmic beats with illumination	Nystagmus probably due to vestibular canal stimulation Suggests that beats are induced by optokinetic stimulation from moving retinal image	Ref. 6
Frequency of sinusoidal oscillation	Response is in phase with head displacement over range from 0.025-0.250 Hz At higher frequencies, response shows some phase lag	Must be neural in origin, because output from utricles shows phase lead at these frequencies	Ref. 1 CRef. 3.202
Labyrinth loss:			Refs. 2, 5, 9
Unilateral	Response is absent when head tilts to defective side		
Bilateral	Response is reduced in both directions. A residual response occurs in the dark and with whole body tilt	Suggests response is not visually instigated and is not a cervico-ocular response	

Key References

1. Anderson, J. H., & Precht, W. (1979). Otolith responses of extraocular muscles during sinusoidal roll rotations. *Brain Research*, 160, 150-154.

2. Berthoz, A., Baker, R., & Precht, W. (1973). Labyrinthine control of inferior oblique motoneurons. *Experimental Brain Research*, 18, 225-241.

*3. Howard, I. P. (1986). The vestibular system. In K. R. Boff, L. Kaufman, & J. P. Thomas (Eds.), *Handbook of perception and human performance: Vol. 1. Sensory processes and perception*. New York: Wiley.

4. Miller, E. F., & Graybiel, A. (1974). Human ocular counter-rolling measured during eight hours of sustained body tilt. *Minerva Otorinolaringologica*, 24, 247-252.

5. Nelson, J. R., & Cope, D. (1971). The otoliths and the ocular counter-torsion reflex. *Archives of Otolaryngology*, 94, 40-50.

6. Petrov, A. P., & Zenkin, G.M. (1973). Torsional eye movements and constancy of the visual field. *Vision Research*, 13, 2465-2477.

7. Schöne, H. (1962). Über den Einfluss der Schwerkraft auf die Augenrollung und auf die Wahrnehmung der Lage im Raum. *Zeitschrift für Vergleichende Physiologie*, 46, 57-87.

8. Scott, A. B. (1967). Extraocular muscles and head tilting. *Archives of Ophthalmology*, 78, 397-399.

9. Smiles, K. A., Hite, D., Hyams, V. J., & Junker, A. M. (1975). Effect of labyrinthectomy on the dynamic vestibulo-ocular counterroll reflex in the Rhesus monkey. *Aviation Space and Environmental Medicine*, 46, 1017-1022.

Cross References

1.917 Factors affecting the vestibulo-ocular reflex;

1.958 Eye movements induced by head and body movements;

1.960 Factors affecting coordination of head rotation and eye movements;

3.202 Dynamics of the otolith organs;

3.210 Vestibular illusions;

10.1001 Techniques for body self-rotation without surface contact in micro-gravitational environments

1.958 Eye Movements Induced by Head and Body Movements

Key Terms

Body rotation; cervico-ocular nystagmus; countertorsion; eye-head coordination; head tilt; involuntary eye movements; nystagmus; optokinetic nystagmus; postrotary nystagmus; rotary acceleration effects; stabilization; vestibular function; visual fixation

General Description

When the head or body moves, there are characteristic associated eye movements based on various sensory systems of the body and typically result in stabilization of the body, head, and retinal image. The table lists various movements of the head or body and characteristics, origin, and function of the associated eye movements.

Table 1. Characteristics, origin, and function of eye movements associated with particular head or body movements.

Movements of the Head or Body	Characteristics of the Associated Eye Movements	Origin of the Eye Movements	Function of the Eye Movements
Rotary acceleration	Nystagmic slow phase that is in phase with head position	Vestibular canals	Compensatory pursuit (followed by a saccadic return of gaze)
Rotary acceleration	Nystagmic deviation in phase with head velocity	Vestibular canals	Deviation of eyes
Deceleration (recovery from vestibular adaptation)	Postrotary nystagmus (followed by secondary nystagmus)	Vestibular canals	Phase reversed for ~20 sec (followed by phase-reversed nystagmus)
Ferris-wheel rotation of head and body about a horizontal axis	Horizontal nystagmus	Possibly vestibular canals or utricles	Sequential eye deviations
Low or constant velocities of body rotation relative to visual environment	Optokinetic pursuit of visual environment	Vision	Stabilized retinal image of visual environment
Cessation of relative movement of visual environment with respect to head	Optokinetic afternystagmus (followed by secondary optokinetic nystagmus)	Possibly a visual integrator	Continuation of optokinetic nystagmus (followed by a phase-reversed nystagmus)
Linear acceleration of body	Deviation	Otolith organ	Possible stabilization of visual environment retinal image
Head tilt	Countertorsion	Utricle	Tends to maintain the eyes upright relative to gravity
Head inclination	Inclination	Otolith organ	Tends to maintain the eyes in a level position
Barbeque rotation of body	Alternating deviation	Utricles	Attempts to stabilize visual image on the retina
Neck rotation	Cervico-ocular nystagmus and deviation	Proprioreceptors	Assists in stabilization of retinal image
Twisting of trunk	Arthro-ocular nystagmus	Proprioreceptors	Assists in retinal image stabilization

Key References

1. Howard, I. (1986). The perception of posture, self motion, and the visual vertical. In K. R. Boff, L. Kaufman, & J. P. Thomas

(Eds.), *Handbook of perception and human performance: Vol. I. Sensory processes and perception*. New York: Wiley.

Cross References

1.917 Factors affecting the vestibulo-ocular reflex;

1.921 Vestibulo-ocular nystagmus during and after aircraft spin;

1.922 Vestibulo-ocular nystagmus: interaction of quick phase nystag-

mus and saccades with eye/head tracking;

1.923 Factors influencing duration of postrotary nystagmus;

1.924 Optokinetic nystagmus and circularvection (illusory self-motion);

1.925 Optokinetic nystagmus: effect of instructions;

1.926 Factors affecting gain of vestibulo-ocular reflex;

1.927 Vestibulo-ocular reflex in the presence of visual distortion;

1.928 Gain of vestibular nystagmus: effect of object distance;

1.929 Vestibular nystagmus: effect of attention;

1.930 Vestibular nystagmus: effect of angular acceleration and deceleration;

1.959 Eye torsion in response to lateral head tilt

1.959 Eye Torsion in Response to Lateral Head Tilt

Key Terms

Compensatory eye movements; compensatory saccades; cyclorotation; head tilt; horizontal disparity; ocular counter-torsion; ocular torsion; optokinetic reflex; torsional eye movements; vertical retinal image disparity; visual orientation

General Description

When the head is tilted in a gravitational field, the eyes undergo torsional movements in an attempt to minimize retinal image motion without introducing vertical disparity.

When an observer tilts his head laterally in a steady, uniform manner, two distinct types of rotational eye movements can be detected. Initially, the eye rotates slowly in a direction opposing that in which the observer's head is tilted (ocular countertorsion), and the spatial orientation of the eye with respect to the true vertical (external gravitational frame of reference) remains relatively invariant. This ocular countertorsion is, in turn, immediately followed by a rapid (saccadic) rotation about the visual axis in the direction of the head tilt (i.e., an ocular torsion), such that the horizontal meridian of the eye is shifted away from the true horizontal to be once more in the plane of regard or Vieth-Müller horopter (Fig. 1).

In dark conditions, the eye "drifts" smoothly in the direction of head tilt, with little alternation between slow and fast movements.

Methods

Test Conditions

- Trials conducted under normal light or dark conditions; fixation point was small spot or dim lamp located 1.2 m in front of observer
- Movements of right eye recorded and measured using suction-cap device equipped with miniature lamp and lens that projected image of horizontally oriented bulb filament onto slit kymograph
- Head tilts recorded and measured using second lamp attached to plexiglass mask fit to face and head that constrained head movements
- Movements of right eye and head orientation recorded continuously on kymograph using photosensitive paper moving at speed of 15 mm/sec; eye movements sometimes also simultaneously recorded photo-

graphically (at rate of several frames per trial) using automated still camera temporally coordinated with kymograph

- Head maintained in either (initial, brief) vertical or tilted (50 deg peak-to-peak) position; trials lasted 4-6 sec
- Head tilts induced at average speed of 10 deg/sec and ranged from 5 deg clockwise (CW) to 50 deg counterclockwise (CCW)

Experimental Procedure

- Independent variables: magnitude and direction of head tilt
- Dependent variables: amplitude, direction, and velocity of eye movement
- Observer's task: fixate on small spot
- 6 observers, with an unknown amount of practice

Experimental Results

- Irrespective of either magnitude or direction of head tilt, two distinct types of eye movements occur when head is tilted in normal ambient lighting: an initial slow (stabilization) phase of movement in a direction opposing that of head tilt, which is immediately followed by a rapid saccadic movement in the direction of head tilt. During the slow-movement phase, the eye steadily rotates to maintain (stabilize) its spatial orientation relative to true vertical and so

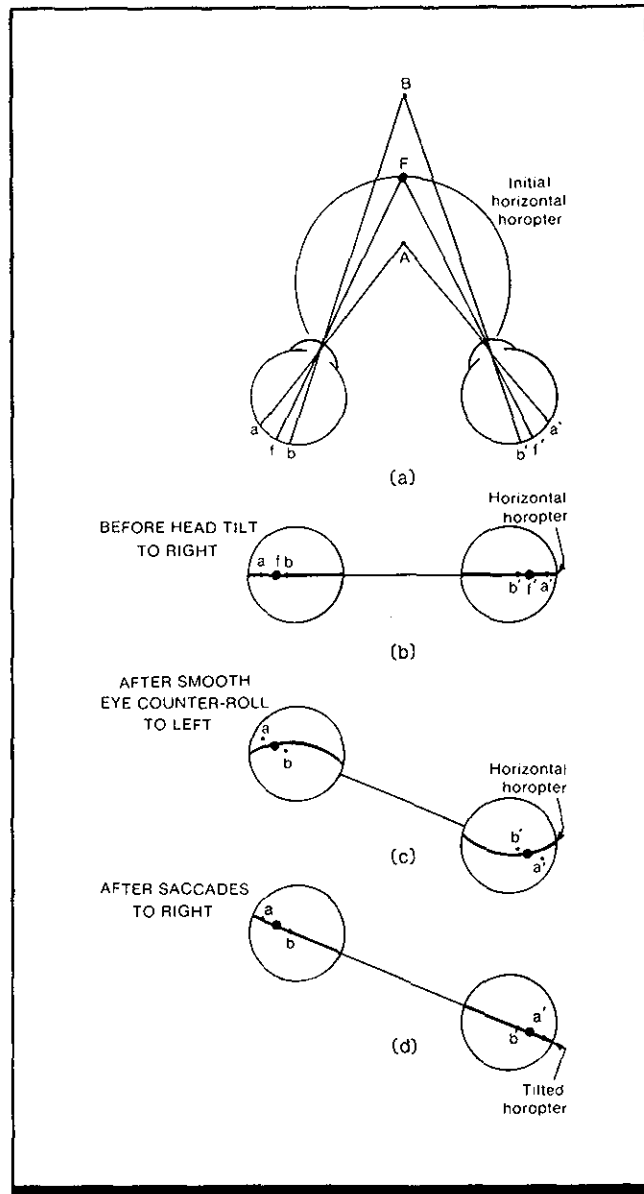

Figure 1. Eye movements to compensate for vertical or horizontal disparity as a function of lateral head tilt. Eyes viewed from above for (a) and from rear for (b, c, and d). (a) Convergence of left and right eyes on centermost of three collinear points, AFB , with head in vertical position. Vieth-Müller horopter, an imagery circle in the horizontal plane of regard, is also shown. (b) Positions of retinal images of collinear points AFB in left ($a/f/b$) and right ($a'/f'/b'$) eyes with head in vertical position. The heavy line on each eye is the horopter. (c) Retinal image positions of points AFB following lateral head tilt. Slow ocular movements of left and right eyes minimize shifting of retinal image, thus stabilizing visual percept, but introducing binocular vertical disparity relative to initial Vieth-Müller horopter. (d) Saccadic eye movements rapidly eliminate binocular disparity in retinal image positions of points AFB . New Vieth-Müller horopter is correspondingly shifted relative to true horizon. (From *Handbook of perception and human performance*)

minimizes retinal image slippage. However, this introduces vertical disparity (Fig. 1c) which is eliminated by torsional saccades (Fig. 1d). Torsional saccades are 0.5-8 deg in amplitude and occur at speeds ranging from 100-200 deg/sec.

- In some instances, saccadic torsions do not completely eliminate the smooth counterrolling. For example, a series of several saccades under head tilt conditions of 45 deg counterclockwise (CCW) may leave a residual torsional angle as large as 12-15 deg.
- Under dark conditions with eyes fixated on a dimly illuminated point, eye movement smoothly follows head movement with a slight lag and includes fewer torsional saccades of various amplitudes. This type of movement may be called "torsional drift."
- In the light, increasing speed of head tilt has no appreciable influence on either total number of rapid torsional saccades or duration of slow movements. However, rapid tilting of the head reduces torsional drift in the dark. Jerking head-tilt motion frequently induces rapid torsional saccades, but smoothing head motion does not lengthen the slow-movement phase.
- Changing the location of the fixation point has no discernible influence on torsional saccades.

Variability

Both the amplitude and total number of torsional saccades exhibited by observers varied on a highly idiosyncratic basis. As head tilt increased from 0 (vertical) to 50 deg, the total number of saccadic torsions exhibited by different observers ranged from as low as five or six to as high as 10-13.

Repeatability/Comparison with Other Studies

The amplitudes of the residual torsional angles found in the present investigation (Ref. 3) exceeded the limits reported in other studies (e.g., Ref. 1); the number of observers participating, number of trials to which observers were subjected, and/or range of head tilt amplitudes incorporated in the present investigation (Ref. 3) were less extensive.

Constraints

- Generalization of these results is risky because of lack of information about experimental variables (e.g., ambient illumination levels and relevant characteristics of observers).

Key References

1. Belcher, S. J. (1964). Ocular torsion. *British Journal of Physiological Optics*, 21, 1-20.
2. Merker, B. H., & Held, R. (1981). Eye torsion and the apparent horizon under head tilt and visual field rotation. *Vision Research*, 19, 543-547.
- *3. Petrov, A. P., & Zenkin, G. M. (1973). Torsional eye movements

and constancy of the visual field. *Vision Research*, 13, 2465-2477.

4. Udo de Haes, H. A. (1970). Stability of the apparent vertical and ocular counter-torsion as a function of lateral tilt. *Perception & Psychophysics*, 8, 137-142.
5. Yarbus, A. L. (1967). *Eye movements and vision*. New York: Plenum.

Cross References

- 1.956 Eye torsion: effects of angular disparity in binocular display patterns;
- 1.957 Factors affecting counter-torsion of the eyes;
- 5.801 Factors affecting judgment of the visual vertical;

5.803 Perceived displacement of the horizon with head tilt and visual display rotation;

5.804 Body tilt: effects on perceived target orientation (the Aubert and Müller effects);

Handbook of perception and human performance, Ch. 10, Sect. 3.5

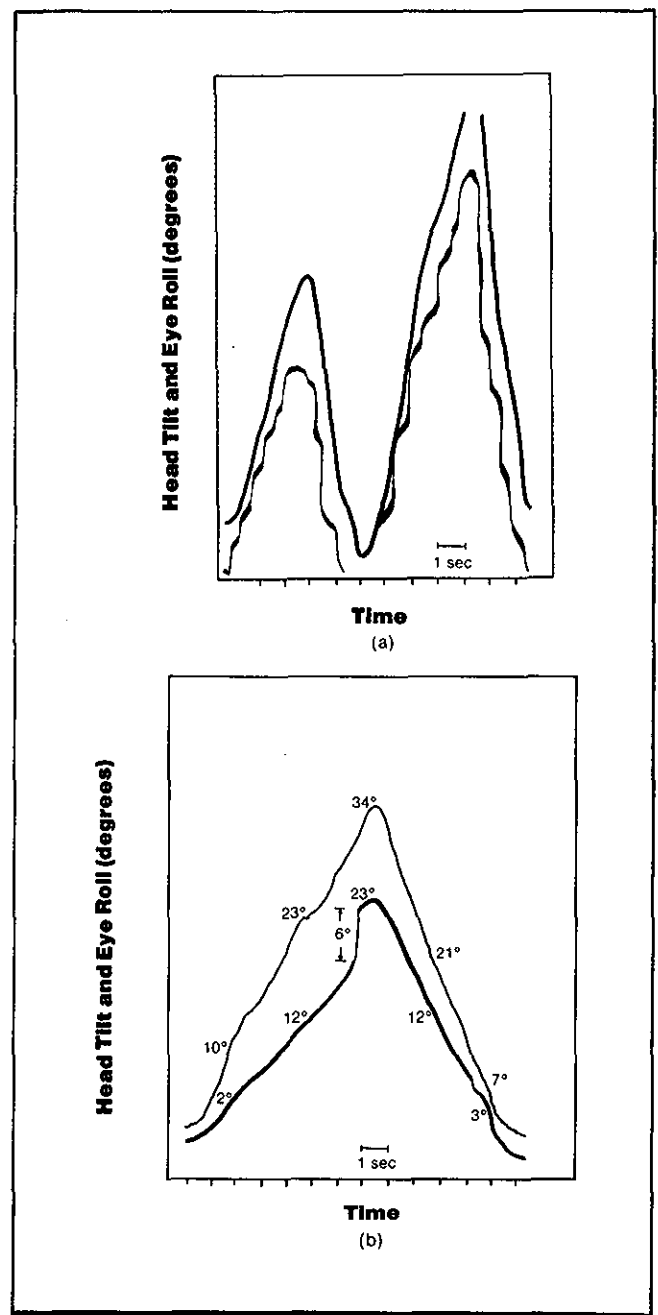

Figure 2. Eye movements generated as a consequence of lateral head tilt about visual axis. Ordinate gives degree of lateral head tilt (smooth upper curves) and eye rotation in space (lower curves). Abscissae give elapsed time in seconds. (a) Plots of eye movements for two lateral head tilts with a peak tilt of 25 and 50 deg. Slow eye movements in opposite direction of head tilt (to decelerate shift of retinal image) are immediately followed by rapid saccadic movements (to accelerate the image shift). (b) Eye movements for 34 deg lateral head tilt in a dark room. Compared to (a), slow eye movements are ineffective in minimizing retinal image shift and the total number of torsional saccades is reduced. (After Ref. 3)

1.960 Factors Affecting the Coordination of Head Rotation and Eye Movements

Key Terms

Eye-head coordination; head rotation; vestibulo-ocular interaction; visual fixation; visually coupled systems

General Description

When an observer changes his or her gaze towards an eccentrically placed visual target, the response is usually accomplished by coordinated rotations of the head and eyes. Experiments indicate that such rotations are determined by characteristics of the oculomotor and visual systems and of the environment. The table lists some of the factors known

to influence coordination of head and eye movements, indicates (when relevant) whether the eye movements are under preprogrammed or vestibular control, summarizes how the factors affect head-eye coordination, and cites both individual entries and outside research sources of additional information.

Factor	Programmed or Vestibular Control	Effects	References
Voluntary versus passive movement of the head	Saccadic eye movements are preprogrammed if head is voluntarily moved to direct gaze towards target. Eye movements are under vestibular control for passive head movements. The compensatory return eye movement is always under vestibular control	When an observer's head is passively moved, the saccadic eye movement occurring in the same direction is initiated after the head has started to move rather than effectively before (as in voluntary movements of the head)	Refs. 3, 6 CRefs. 1.925, 1.958
Dark versus illuminated surroundings	The saccade induced by a voluntary head movement in the dark is under vestibular control, whereas it is preprogrammed in illuminated surroundings. In both light and dark the slow return motion of the eyes is under vestibular control	The saccade induced by either passive or voluntary head movement is delayed in the dark, and the slow return motion of the eyes occurs for both voluntary and passive movements of the head	Ref. 1 CRef 1.911
Effort made in fixating a target	Saccades induced by voluntary head movements in which there is no attempt to fixate a target are under vestibular control. When the observer attempts to fixate a target, the saccade produced by voluntary head movement is preprogrammed	The saccade produced by voluntary movement of the head is delayed if the observer makes no attempt to fixate a target. The saccade occurs before the voluntary head movement when effort is made to fixate a target	Ref. 5 CRefs. 1.911, 1.913, 1.914, 1.929
Velocity of head movement	Not relevant	The amplitude of the saccade is reduced to take account of head movement	Ref. 7
Knowledge of target location	Not relevant	When the observer knows the timing and location of the target, the head is moved just before the target appears; this movement is followed by any necessary corrective saccades when the target is presented	Ref. 2
Random versus regular motion of the target	Not relevant	Only the eyes are moved when the observer pursues a visual target that is moving randomly or with high velocity. Targets moving regularly with a frequency of <1 Hz are pursued using a combination of eye and head movements, with corrective saccades when necessary	Ref. 4

Constraints

- Interactions may occur between the factors affecting the coordination of head and eye movements.

Key References

1. Barnes, G. R. (1979). Vestibulo-ocular function during coordinated head and eye movements to acquire visual targets. *Journal of Physiology*, 287, 127-147.
2. Bizzi, E., Kalil, R. E., & Marasso, P. (1972). Two modes of ac-

tive eye-head coordination. *Brain Research*, 40, 45-48.

3. Bizzi, E., Kalil, R. E., & Tagliasco, V. (1971). Eyehead coordination in monkeys: Evidence for centrally patterned organization. *Science*, 173, 452-454.

4. Gresty, M. A., & Leech, J. (1977). Coordination of the head

and eyes in pursuit of predictable and random target motion. *Aviation Space and Environmental Medicine*, 48, 741-744.

5. Henriksson, N. G., Novotny, M., & Tjernstrom, O. (1974). Eye movements as a function of active head turnings. *Acta Otolaryngologica*, 77, 86-91.

6. Melvill Jones, G. (1964). Prevalence of anti-compensatory oculomotor response during rapid head rotation. *Aerospace Medicine*, 35, 965-968.

7. Morasso, P., Bizzi, E., & Dichgans, J. (1973). Adjustment of saccade characteristics during head movements. *Experimental Brain Research*, 16, 492-500.

Cross References

- 1.911 Visual fixation stability in the dark;

1.913 Visual fixation: relationship between head and eye movements;

- 1.914 Monocular fixation on stationary targets;

1.925 Optokinetic nystagmus: effect of instructions;

- 1.929 Vestibular nystagmus: effect of attention;

1.958 Eye movements induced by head and body movements

Notes



Organization of Entries

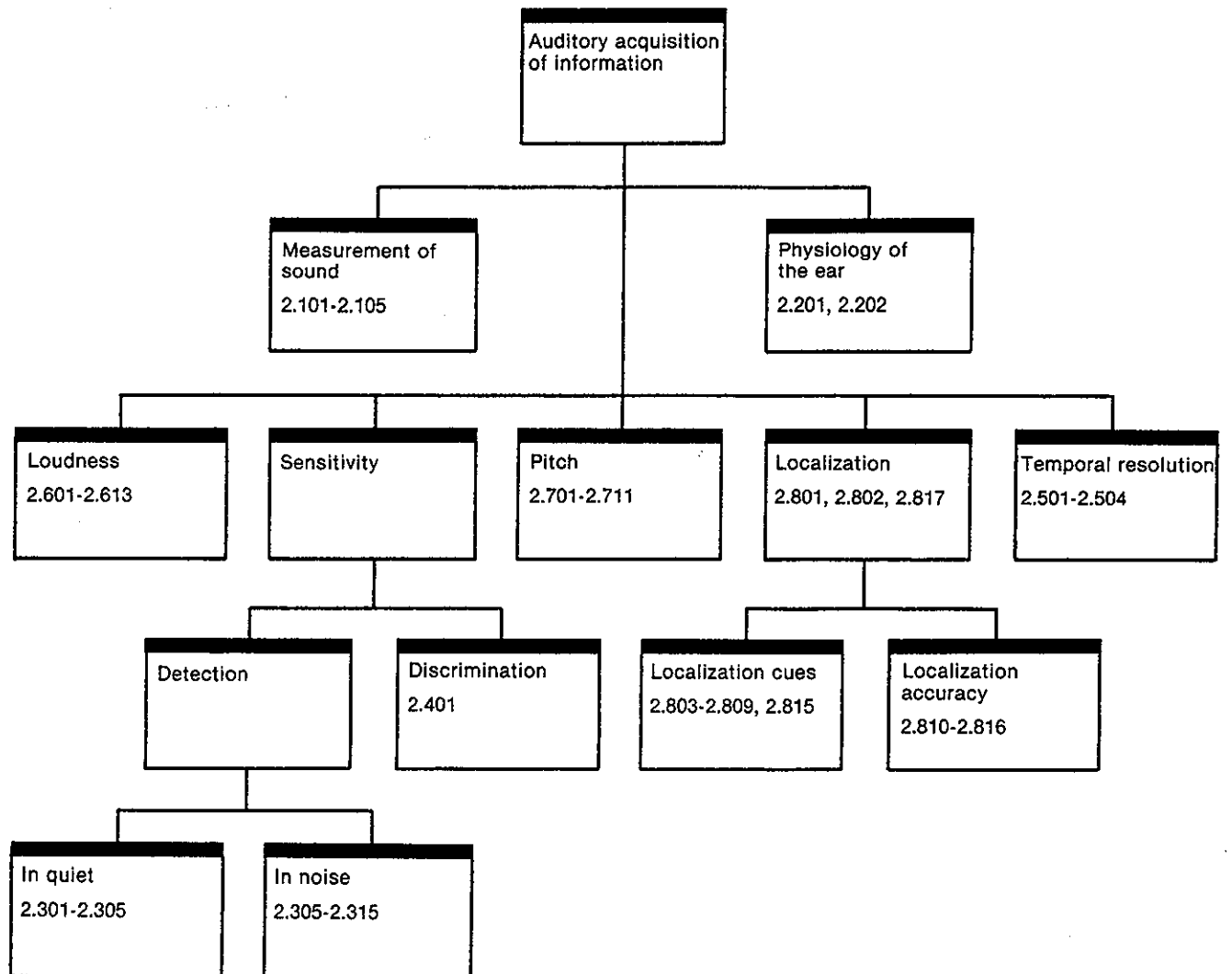

Contents

Section 2.1 Measurement of Sound

- | | |
|---|---|
| 2.101 Sound Propagation | 2.104 Calibration Procedures and Instruments for Measuring Sound |
| 2.102 Physical Parameters and Spectral Analysis of Sound | 2.105 Noise and Distortion |
| 2.103 Measurement of Sound Amplitude | |

Section 2.2 Physiology of the Ear

- 2.201** Anatomy and Physiology of the Ear
2.202 Acoustic Reflex

Section 2.3 Detection

- | | |
|---|---|
| 2.301 Factors Affecting Auditory Sensitivity in Quiet | 2.309 Auditory Sensitivity in Noise: Pure-Tone Masking |
| 2.302 Auditory Sensitivity in Quiet: Effect of Frequency | 2.310 Auditory Sensitivity in Noise: Effect of Bandwidth of Multitone Signals |
| 2.303 Auditory Sensitivity in Quiet: Effect of Age | 2.311 Auditory Sensitivity in Noise: Effect of Signal Duration |
| 2.304 Auditory Sensitivity in Quiet: Underwater Listening | 2.312 Auditory Sensitivity in Noise: Nonsimultaneous Masking |
| 2.305 Auditory Sensitivity in Quiet and in Noise: Effect of Binaural Versus Monaural Listening | 2.313 Auditory Sensitivity in Noise: Interaural Masking |
| 2.306 Factors Affecting Auditory Sensitivity in the Presence of Masking Noise | 2.314 Binaural Reduction of Masking: Effect of Signal Frequency and Listening Conditions |
| 2.307 Auditory Sensitivity in Noise: Broad-Band Noise Masking | 2.315 Binaural Reduction of Masking: Effect of Interaural Phase Differences |
| 2.308 Auditory Sensitivity in Noise: Narrow-Band Noise Masking | |

Section 2.4 Discrimination

- 2.401** Intensity Discrimination of Random Noise and "Square-Wave" Noise

Section 2.5 Temporal Resolution

- | | |
|--|---|
| 2.501 Sensitivity to Amplitude Modulation of Broad-Band Noise | 2.503 Discrimination of Event Duration |
| 2.502 Detection of Gaps in Continuous Noise | 2.504 Perceived Event Duration: Effect of Complexity and Familiarity |

Section 2.6 Loudness

- | | |
|--|---|
| 2.601 Factors Influencing Loudness | 2.607 Effect of Duration on the Loudness of Narrow-Band Noise |
| 2.602 Effect of Sound Pressure Level on Loudness | 2.608 Monaural Versus Binaural Loudness |
| 2.603 Effect of Frequency on the Loudness of Pure Tones | 2.609 Effect of Interaural Phase on the Loudness of Masked Tones |
| 2.604 Effect of Bandwidth on the Loudness of Two-Tone Complexes | 2.610 Loudness of Intermittent Stimuli |
| 2.605 Effect of Bandwidth on the Loudness of Broad-Band and Moderate-Band Noise | 2.611 Loudness Reduction Under Masking by Broad-Band Noise and Narrow-Band Noise |
| 2.606 Effect of Bandwidth and Intensity Level on the Loudness of Continuous Noise | 2.612 Loudness Adaptation |
| | 2.613 Loudness Discomfort Level |

Section 2.7 Pitch

- | | |
|---|---|
| 2.701 Factors Affecting Pitch | 2.707 Pitch Shift Following Adaptation to a Tone |
| 2.702 Effect of Frequency on Pitch | 2.708 Pitch Discrimination Under Simultaneous Masking |
| 2.703 Effect of an Interfering Stimulus on the Pitch of Pure Tones | 2.709 Pitch Discrimination Under Nonsimultaneous Masking |
| 2.704 Pitch Recognition with Interpolated Tones | 2.710 Nontonal Pitch |
| 2.705 Effect of Amplitude Envelope on the Pitch of Pure Tones | 2.711 Pitch of Amplitude-Modulated (Square-Wave Gated) Noise |
| 2.706 Binaural Pitch Disparity (Diplacusis) | |
-

Section 2.8 Localization

- | | |
|--|--|
| 2.801 Sound Localization | 2.810 Localization in the Median Plane |
| 2.802 Effects of the Body on a Sound Field | 2.811 Effect of Stimulus Duration on Lateralization of Pure Tones and Noise |
| 2.803 Interaural Intensity Differences | 2.812 Precision of Localization (Minimum Audible Angle) |
| 2.804 Discrimination of Interaural Intensity Differences for Pure Tones | 2.813 Effect of Frequency on the Localization of Pure Tones |
| 2.805 Interaural Time Differences | 2.814 Effect of Static Head Position on Localization |
| 2.806 Discrimination of Interaural Phase Differences for Pure Tones | 2.815 Effect of Visual and Proprioceptive Cues on Localization |
| 2.807 Lateralization of Clicks with Interaural Time Delay | 2.816 Localization in Noise |
| 2.808 Lateralization of Amplitude-Modulated Tones with Interaural Time Delay | 2.817 Echo Suppression in Localization |
| 2.809 Trading Between Interaural Intensity Differences and Interaural Time Differences in Auditory Lateralization | |

Key Terms

- Acoustic coupler, 2.104
 Acoustic reflex, 2.202
 Adaptation, 2.612, 2.701, 2.707, 2.710
 Adaptation pitch, 2.710
 Amplitude envelope, 2.701, 2.705
 Amplitude-modulated noise, 2.711
 Amplitude modulation, 2.501, 2.701, 2.808
 Backward masking, 2.306, 2.312, 2.709
 Bandwidth, 2.102, 2.310, 2.601, 2.604-2.606
 Binaural inhibition, 2.305
 Binaural listening, 2.305, 2.601
 Binaural loudness, 2.608
 Binaural pitch disparity, 2.706
 Binaural summation, 2.305
 Binaural unmasking, 2.305, 2.314, 2.315
 Broadband noise, 2.306, 2.307, 2.310, 2.311, 2.314, 2.315, 2.501, 2.502, 2.611, 2.613, 2.811
 Cochlea, 2.201
 Combination tones, 2.105
 Complex sound, 2.604, 2.606, 2.708, 2.709, 2.711, 2.807, 2.808
 Critical band, 2.307, 2.604, 2.606
 Decibel, 2.103
 Detection, auditory, 2.301-2.315
 Difference threshold. *See* Duration difference threshold; frequency difference threshold
 Diffraction, 2.803
 Diplacusis binauralis, 2.701, 2.706
 Direction, 2.801-2.803, 2.805, 2.812
 Discrimination, intensity, 2.401, 2.501
 Discrimination, pitch, 2.708, 2.709
 Discrimination, temporal, 2.503, 2.504
 Distance, 2.801
 Distortion, aural, 2.105
 Distortion, intermodulation, 2.105
 Dosimeter, 2.104
 Duration, of stimulus, 2.301, 2.306, 2.311, 2.709
 Duration difference threshold, 2.503
 Duration perception, 2.503, 2.504
 Ear, inner, 2.201
 Ear, middle, 2.201, 2.202
 Ear, outer, 2.201
 Echo, 2.817
 Echo pitch, 2.710
 Echo suppression, 2.817
 Edge pitch, 2.710
 Energy splatter, 2.102
 Event duration, 2.503, 2.504
 Facilitation, visual, 2.815
 Forward masking, 2.306, 2.312, 2.313
 Fourier analysis, 2.102
 Frequency, 2.101, 2.301, 2.302, 2.306, 2.601, 2.603, 2.701, 2.709, 2.802-2.806, 2.808, 2.810, 2.812, 2.813
 Frequency difference threshold, 2.711
 Frequency modulation, 2.708
 Gap detection, 2.502, 2.503
 Gated noise, 2.711
 Harmonic distortion, 2.105
 Harmonics, 2.102, 2.708
 Headphone, 2.104
 Head position, 2.814
 Head rotation, 2.814
 Intensity. *See* Sound intensity
 Intensity differences, interaural, 2.801, 2.803, 2.804, 2.809
 Intensity discrimination, 2.401, 2.501
 Interaural intensity differences, 2.801, 2.803, 2.804, 2.809
 Interaural masking, 2.313
 Interaural phase differences, 2.314, 2.315, 2.601, 2.609, 2.801, 2.806
 Interaural time differences, 2.315, 2.801, 2.805-2.809, 2.811, 2.817
 Interference, auditory, 2.703, 2.704
 Intermittent stimulation, 2.601, 2.610
 Intersensory interactions, 2.814
 Inverse square law, 2.103
 Lateralization, auditory, 2.801; 2.803-2.809, 2.811
 Localization, auditory, 2.801-2.817
 Loudness, 2.601-2.613
 Loudness, binaural, 2.608
 Loudness, monaural, 2.608
 Loudness adaptation, 2.601, 2.612
 Loudness discomfort level, 2.613
 Loudness reduction, 2.611
 Loudness summation, 2.604, 2.606, 2.608
 Masking, auditory, 2.105, 2.301, 2.305, 2.311, 2.313, 2.601, 2.605, 2.701, 2.703. *See also subentries below and* Noise Masking
 Masking, backward, 2.306, 2.312, 2.709
 Masking, forward, 2.306, 2.312, 2.313
 Masking, interaural, 2.313
 Masking, pure-tone, 2.309
 Masking, remote, 2.314
 Masking, simultaneous, 2.307-2.311, 2.313, 2.314, 2.708
 Masking level difference, 2.305, 2.314, 2.315
 Median plane, 2.810
 Mel scale, 2.702
 Microphone, 2.104
 Minimum audible angle, 2.806, 2.812, 2.816
 Minimum audible field, 2.302
 Minimum audible pressure, 2.302
 Mistuning, 2.708
 Monaural listening, 2.305, 2.601
 Monaural loudness, 2.608
 Multi-tone complex, 2.310
 Narrow-band noise, 2.306, 2.308, 2.312, 2.314, 2.502, 2.607, 2.611, 2.613, 2.810, 2.811
 Noise, 2.105, 2.606, 2.711
 Noise, bandpass, 2.703
 Noise, broadband, 2.306, 2.307, 2.310, 2.311, 2.314, 2.315, 2.501, 2.502, 2.611, 2.613, 2.811
 Noise, high-pass, 2.810
 Noise, low-pass, 2.810
 Noise, narrow-band, 2.306, 2.308, 2.312, 2.314, 2.502, 2.607, 2.611, 2.613, 2.810, 2.811
 Noise, pink, 2.105
 Noise, random, 2.401
 Noise, square-wave, 2.401
 Noise, white, 2.105, 2.602, 2.605, 2.608, 2.611
 Noise bandwidth, 2.306
 Noise exposure, 2.301
 Noise impulse, 2.809
 Noise-induced permanent threshold shift, 2.301
 Noise masking, 2.306, 2.308-2.312, 2.314, 2.315, 2.609, 2.611, 2.816. *See also* Masking
 Noise spectrum, 2.605
 Non-tonal pitch, 2.710
 Onset asynchrony, 2.709
 Overtones, 2.102
 Partial masking, 2.611
 Peak clipping, 2.401
 Phase differences, interaural, 2.314, 2.315, 2.601, 2.609, 2.801, 2.806
 Physiology, auditory, 2.201, 2.202
 Pitch, 2.701-2.711
 Pitch, echo, 2.710
 Pitch, edge, 2.710
 Pitch, nontonal, 2.710
 Pitch, repetition, 2.710
 Pitch discrimination, 2.708, 2.709
 Pitch disparity, binaural, 2.706
 Pitch recognition, 2.704
 Pitch shift, 2.703, 2.707
 Postural adaptation, 2.814
 Precedence effect, 2.817
 Presbycusis, 2.301, 2.303
 Pulse train, 2.610
 Pure tones, 2.806
 Repetition pitch, 2.710
 Resonance, 2.101
 Reverberation, 2.709
 Sensation level, 2.103
 Sensation magnitude, 2.602
 Sensitivity, auditory, 2.103, 2.301-2.312
 Sex differences, 2.303
 Signal detection, 2.306-2.313, 2.315, 2.708, 2.709
 Simultaneous masking, 2.307-2.311, 2.313, 2.314, 2.708
 Sociocusis, 2.303
 Sound, speed of, 2.101
 Sound intensity, 2.101, 2.103, 2.104, 2.202, 2.601-2.609, 2.611-2.613, 2.701, 2.802
 Sound measurement, 2.101-2.105
 Sound pressure transfer function, 2.802
 Sound propagation, 2.101, 2.201
 Sound shadow, 2.802-2.804
 Spatial localization. *See* Localization, auditory
 Spectral analysis, 2.102, 2.104
 Spectral distribution, 2.102
 Stapedius muscle, 2.202
 Straightahead, apparent, 2.814
 Summation, binaural, 2.305
 Summation, loudness, 2.604, 2.606, 2.608
 Summation, temporal, 2.311, 2.312, 2.607, 2.610
 Temporal discrimination, 2.503, 2.504
 Temporal resolution, 2.501-2.504
 Temporal summation, 2.311, 2.312, 2.607, 2.610
 Threshold shift, noise-induced permanent, 2.301
 Threshold shift, temporary, 2.202, 2.301
 Time differences, interaural, 2.315, 2.801, 2.805-2.809, 2.811, 2.817
 Time-intensity tradeoff, 2.809
 Tone intermittency, 2.601
 Underwater listening, 2.304
 Waveform analysis, 2.102
 White noise, 2.105, 2.602, 2.605, 2.608, 2.611

Glossary

- Absolute threshold.** The amount of stimulus energy necessary to just detect the stimulus. Usually taken as the value associated with some specified probability of stimulus detection (typically 0.50 or 0.75).
- Acoustic reflex.** Contraction of two small muscles attached to the conducting bones of the middle ear in response to a high-intensity sound; the contraction dampens sound pressure by increasing acoustic impedance and serves to protect the ear from damage by very loud sound. (CRef. 2.202)
- Adaptation.** A change in the sensitivity of a sensory organ to adjust to the intensity or quality of stimulation prevailing at a given time; adaptation may occur as an increase in sensitivity (as in dark adaptation of the retina) or as a decrease in sensitivity with continued exposure to a constant stimulus. Also called **sensory adaptation**.
- Amplitude modulation.** Modulation of the amplitude of a (usually) constant-frequency carrier in accordance with the strength of a second signal, generally of much lower frequency than the carrier; AM radio utilizes amplitude modulation.
- Anechoic room.** A room in which all surfaces are covered by large wedges of sound-absorbing material to minimize reflections and provide an essentially echo-free or free-field environment.
- Beats.** Periodic fluctuations in amplitude produced by the superposition of sound waves of slightly different frequencies.
- Békésy tracking procedure.** A procedure for measuring auditory thresholds in which the listener presses a switch to reduce the signal level as long as the signal is heard and releases it to increase the signal level when the signal becomes inaudible. When the procedure is continued over several minutes, a zigzag pattern of increasing and decreasing signal levels is produced on a chart recorder designed for the purpose. Threshold is usually calculated as the average of the median points between successive peaks and valleys in this pattern.
- Binaural.** Pertaining to, affecting, or impinging upon both ears; sometimes used to imply identity of the signals to the two ears. (See also **diotic**; **dichotic**.)
- Combination tone.** A secondary tone not present in the stimulus that is heard when two primary tones of widely differing frequencies are presented simultaneously and that is thought to be due to nonlinearity in the response of the human auditory system to sound waves. Combination tones are heard at frequencies that represent the sum and differences of the frequencies of the two primary tones, or the harmonics of the primary tones. They may also occur at frequencies that bear a more complex relation to the primary-tone frequencies.
- Complex sound.** A sound comprising more than one frequency, i.e., a sound that is not a pure sine-wave.
- Critical band.** That frequency bandwidth at which the subjective response to a sound changes abruptly; as measured by loudness, it is the frequency band within which the loudness of a sound of constant total sound pressure remains unaffected by the bandwidth of the sound; as measured by masking, it is the frequency band within which varying the bandwidth of narrow-band masking noise of constant power density does not affect the threshold for a pure tone located at the center frequency of the noise band.
- dB(A).** The relative sound pressure level of a sound in decibels measured using the A weighting network of a sound level meter. (CRef. 2.104)
- Decibel.** The standard unit used to express the ratio of the power levels or pressure levels of two acoustic signals. For power, one decibel = $10 \log P_1/P_2$ (where P_1 and P_2 are the powers of the first and second signals, respectively). For pressure, one decibel = $20 \log p_1/p_2$ (where p_1 and p_2 are the sound pressure levels of the two signals). In most applications, the power or pressure of a signal is expressed relative to a reference value of $P_2 = 10^{-12} \text{ W/m}^2$ for power and $p_2 = 20 \text{ } \mu\text{Pa}$ (or $0.0002 \text{ dynes/cm}^2$) for pressure.
- Dependent variable.** The response to a stimulus presentation measured by the investigator to assess the effect of an experimental treatment or independent variable in an experiment; for example, the investigator might measure the auditory threshold (dependent variable) for several tones that differ in frequency (independent variable). (Compare **independent variable**.)
- Dichotic.** Pertaining to listening conditions in which the sound stimulus to the left and right ears is not identical but differs with respect to some property (such as frequency or phase).
- Difference threshold.** The least amount by which two stimuli must differ along some dimension (such as sound pressure level or frequency) to be judged as nonidentical. Usually taken as the difference value associated with some specified probability of detecting a difference (typically 0.50 or 0.75).
- Diotic.** Pertaining to listening conditions in which the sound stimulus to both ears is identical.
- Diplacusis binauralis.** A condition in which a tone of given frequency is perceived as having a different pitch in the left and right ears; most normal listeners show at least some degree of diplacusis.
- Factorial design.** An experimental design in which every level or state of each independent variable is presented in combination with every level or state of every other independent variable.
- Free field.** A sound field in free space produced by a source that is far enough away from all objects so that they cause no reflections or other disturbances to it.
- Fundamental frequency.** For a complex periodic waveform, the repetition rate of the waveform; i.e., the harmonic component that has the lowest frequency (and usually the greatest amplitude). Also called **first harmonic**.
- Hearing threshold level.** The amount (in decibels) by which the level of a sound exceeds the average threshold of audibility of normal listeners as established in national and international standards.
- Independent variable.** The aspect of a stimulus or experimental environment that is varied systematically by the investigator in order to determine its effect on some other variable (i.e., the subject's response). For example, the investigator might systematically alter the frequency of a tone (independent variable) in order to assess the effect of these changes on the observer's auditory threshold (dependent variable). (Compare **dependent variable**.)
- Interaural phase.** The relative phase of a tone in the left and right ears, generally taken to imply a time in the mechanical activity of the middle ear.
- Interstimulus-onset interval.** The time between the onset of one stimulus and the onset of a second stimulus. Also called **stimulus-onset interval**.
- Inverse square law.** A law stating that the intensity (power) of a sound source is inversely proportional to the square of the distance of the listener from the sound source. (Because intensity is proportional to the square of the sound pressure level, sound pressure is inversely proportional to the distance of the sound source.)
- Lateralization.** Localization of a sound presented (usually dichotically) via earphones in terms of its apparent spatial position along an imaginary line extending from the right to the left ear.

2.0 Auditory Acquisition of Information

- Loudness level.** The loudness level of a sound (in phons) is the sound pressure (in decibels re $20 \mu\text{Pa}$) of a 1000-Hz tone judged equal in loudness to the sound being measured.
- Mask.** See *masking*.
- Masking.** A decrease in the audibility of one sound due to the presence of another sound (the *mask*) which occurs simultaneously or close in time to the first sound.
- Medial plane.** The vertical plane passing through the middle of the body from front to back and dividing the body into left and right. Sometimes called *sagittal plane*.
- Mel.** A subjective unit of pitch such that a pure tone of 1000 Hz has a pitch of 1000 mels.
- Method of adjustment.** A psychophysical method of determining a threshold in which the subject (or the experimenter) adjusts the value of the stimulus until it just meets some preset criterion (e.g., just appears audible) or until it is apparently equal to a standard stimulus.
- Method of constant stimuli.** A psychophysical method of determining a threshold in which the subject is presented with several fixed, discrete values of the stimulus and makes a judgment about the presence or absence of the stimulus or indicates its relation to a standard stimulus (e.g., louder, softer).
- Method of limits.** A psychophysical method of determining a threshold in which the experimenter varies a stimulus in an ascending or descending series of small steps and the observer reports whether the stimulus is audible or not or indicates its relation to a standard stimulus.
- Monaural.** Pertaining to, affecting, or impinging upon only one ear.
- Noise spectral level.** The average noise power in a 1-Hz band of noise (in decibels re 10^{-12} W/m^2); also called *noise-power density*.
- Overtone.** A constituent of a complex tone whose frequency is an integral multiple of the fundamental frequency; also called *harmonic* or *upper partial*.
- Phon.** A unit of loudness equal to the number of decibels (re $20 \mu\text{Pa}$) of a 1000-Hz tone that is equal in loudness to the sound being measured. Loudness in phons is termed the loudness level of a sound.
- Probability summation.** The increase in the probability of detecting a stimulus due to an increase in the number of independent opportunities for detection on a given trial (as by hearing with two ears or processing by multiple independent sensory mechanisms). (CRef. 1.814)
- Probit analysis.** A regression-like maximum-likelihood procedure for finding the best-fitting ogive function for a set of binomially distributed data. Originally developed in connection with pharmacological and toxicological assays to compute the lethal or effective dose (dosage affecting 50% of treated organisms); the procedure has also been applied in psychophysical studies in analyzing all-or-nothing (yes/no) responses to compute the 50% threshold (stimulus level eliciting a given response on 50% of trials) and its confidence limits.
- Proprioception.** The sensing of movement and position of the body or its parts.
- Psychometric function.** A mathematical or graphical function expressing the relation between a series of stimuli that vary quantitatively along a given dimension, and the relative frequency with which a subject answers with a certain category of response in judging a particular property of the stimulus (e.g., "yes" and "no" in judging whether a given stimulus is detected, or "less than," "equal to," and "greater than" in comparing the stimulus with a standard stimulus). (CRef. 1.657)
- Pure tone.** A tone of a single frequency produced by sinusoidal vibrations and without overtones.
- Randomized design.** An experimental design in which the various levels of the independent variable are presented in random order within a given block of trials or experimental session.
- Sensation level.** The amount (in decibels) by which the level of a sound exceeds the threshold of audibility of the sound for a given listener.
- Sensitivity.** In a general sense, the ability to detect stimulation; in psychophysical studies, refers in particular to the ability to be affected by and respond to low-intensity stimuli or to slight stimulus differences; commonly expressed as the reciprocal of measured threshold.
- Signal-to-noise ratio.** The ratio of the intensity of a signal to the intensity of noise in the absence of the signal. In most auditory studies, the signal-to-noise (S/N) ratio is measured as the relative sound pressure level of the signal and noise in decibels re $20 \mu\text{Pa}$, so that an S/N ratio of zero indicates that signal and noise are of equal amplitude, while positive and negative values indicate that the signal is of greater or lesser amplitude than the noise, respectively.
- Sine wave.** A periodic waveform in which the amplitude of displacement at each point is proportional to the sine of the phase angle of the displacement.
- Sinusoidal.** Varying according to a sine function.
- Sone.** A subjective unit of loudness equal to the loudness of a 1000 Hz tone presented binaurally at an intensity of 40 dB above the listener's threshold (or 40 dB SPL for the "average" listener).
- Sound pressure level.** The amount (in decibels) by which the level of a sound exceeds the reference level of $20 \mu\text{Pa}$ (or $0.0002 \text{ dynes/cm}^2$).
- Staircase procedure.** A variant of the method of limits for determining a psychophysical threshold in which the value of the stimulus on a given trial is increased or decreased depending on the observer's response on the previous trial or group of trials.
- Standard deviation.** Square root of the average squared deviation from the mean of the observations in a given sample. It is a measure of the dispersion of scores or observations in the sample.
- Standard error of the mean.** The standard deviation of the sampling distribution of the mean; mathematically, the standard deviation of the given data sample divided by the square root of one less than the number of observations. It describes the variability of the mean over repeated sampling.
- Threshold.** A statistically determined boundary value along a given stimulus dimension that separates the stimuli eliciting one response from the stimuli eliciting a different response or no response (e.g., the point associated with a transition from "not audible" to "audible" or from "greater than" to "equal to" or "less than"). (CRef. 1.657) (See also *absolute threshold*; *difference threshold*; *psychometric function*.)
- T-test.** A statistical test used to compare the mean of a given sample with the mean of the population from which the sample is drawn or with the mean of a second sample in order to determine the significance of an experimental effect (i.e., the probability that the results observed were due to the experimental treatment rather than to chance). Also known as *Student's t-test*.
- Two-alternative forced-choice paradigm.** An experimental procedure in which the subject is presented on each trial with one of two alternative stimuli and must indicate which stimulus occurred; a response must be made on each trial even if the subject must guess. Commonly referred to as a "criterion-free" method of determining sensitivity.
- White noise.** Random noise whose noise spectral level (noise-power density) is uniform over a wide frequency range; termed "white noise" by analogy to white light.

Section 2.0 Auditory Acquisition of Information

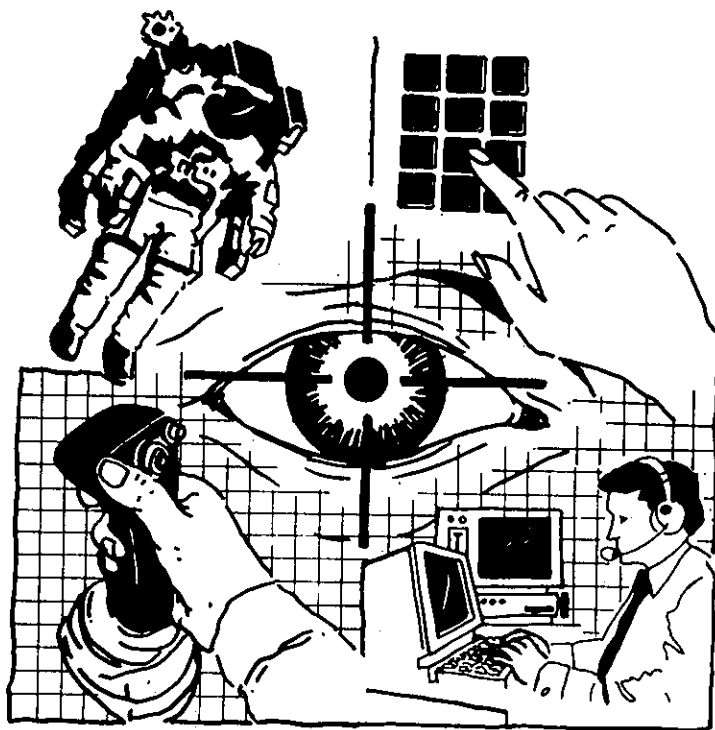

2.101 Sound Propagation

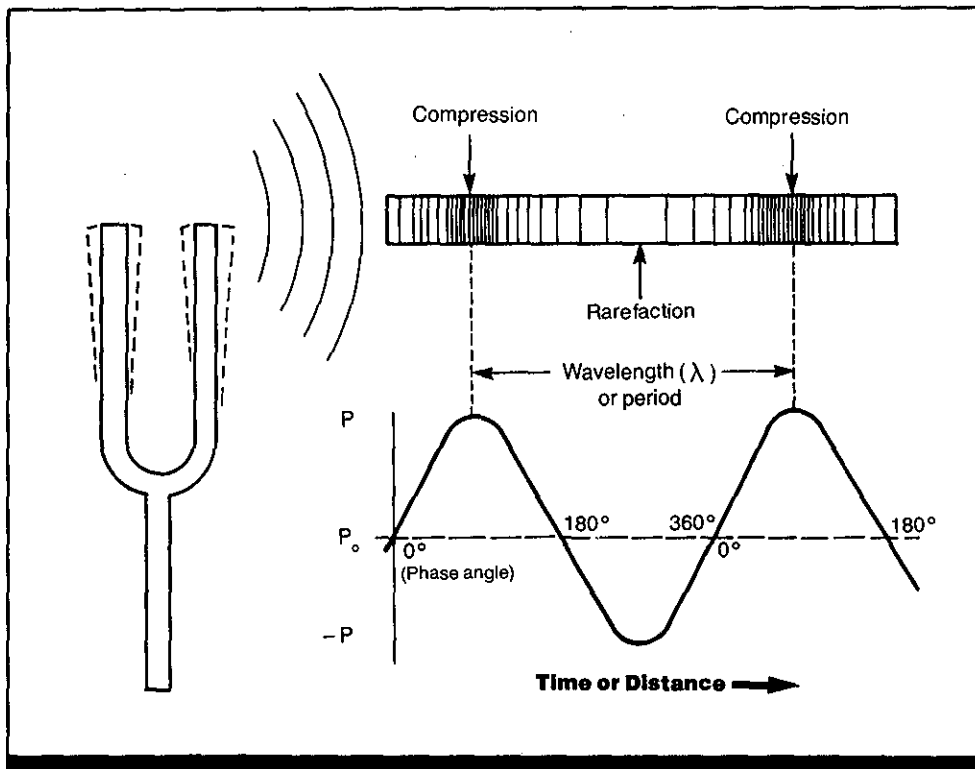

Figure 1. Propagation of sound. As the prongs of a tuning fork move back and forth in vibration, air molecules are displaced and oscillate in position around a central location. This leads to alternate compression and rarefaction at the same location in space as time progresses, and to alternate bands of compression and rarefaction over space at a given moment in time (top of figure). The graph at the bottom of the figure shows the pressure changes produced by the displacement of air molecules as a function of time for a given spatial location in front of the tuning fork or, alternatively, pressure changes as a function of distance from the sound source for a given instant in time. Pressure changes oscillate around the normal or static pressure, P_0 , reaching a maximum at P and a minimum at $-P$. The distance in space between successive pressure peaks of a sound wave at a given moment in time is the wavelength of the sound. The time interval between successive pressure peaks at a given spatial location is the period of the sound wave. (From Ref. 3)

Key Terms

Frequency; resonance; sound intensity; sound propagation; speed of sound

General Description

Sound is a physical disturbance in an elastic medium and cannot exist in the absence of a medium, that is, in a vacuum. The disturbance can be described in terms of pressure changes, particle velocity, or particle displacement. These three measures are not independent but depend on one another according to the laws of physics for elastic media. Particle displacement and particle velocity oscillate around a value of zero. In contrast, sound pressure is a change in pressure that takes place around some reference or static pressure, usually normal atmospheric pressure.

Sound originates from vibrating bodies. For example, when a tuning fork is struck, its prongs vibrate. Moving in one direction, the prongs push the air particles before them

to create a small increase in pressure (Fig. 1). When the prongs reach the end of their displacement, the pressure is maximal. Then they move the opposite way, bringing the pressure through its static value to a minimum that occurs at the other end of their displacement. The particles set in motion by the tuning fork set neighboring particles in motion. These particles then set their neighboring particles in motion, and so on. Thus the pressure changes (i.e., the sound) propagate through the air as a traveling wave. Sound cannot propagate through a vacuum, because there are no particles to transfer the motion.

Speed of Sound

The propagation of sound through a medium takes time; how much time depends on the medium. In air, the speed of

sound is approximately 343 m/sec measured in dry air at 20°C. The speed of sound, c , in any gas can be calculated as

$$c = \sqrt{\gamma RT/M} \quad (1)$$

where γ (~ 1.401 in dry air at 20°C) is the ratio of the specific heat at constant pressure to that at constant volume, R is the gas constant ($= 8,314.3 \text{ (g m}^2\text{/sec}^2\text{)/K per mole}$), T is the absolute temperature (in degrees Kelvin), and M is the molecular weight of the gas ($\sim 28.98 \text{ g/mol}$ for dry air). Thus the speed of sound in air is approximately proportional to \sqrt{T} and independent of the static pressure. Because the molecular weight of air decreases as the humidity increases, the speed of sound is faster in humid air than in dry air, although the effect is relatively small. For example, the speed of sound is about 0.4% faster in air with 100% relative humidity than in dry air at 20°C. In liquids and solids, on the other hand, speed of sound is considerably faster. In water, for example, it is about 1,500 m/sec. Table 1 shows the speed of sound in some different media. Generally, the lighter and the stiffer the medium, the faster the sound travels.

Frequency, Amplitude, and Phase

The simplest sound (and the sound produced by a tuning fork) is a **sine wave**, i.e., a sound in which pressure changes over time (or distance) can be described as a sine function. Sine waves are of special interest because, according to Fourier's theorem, any complex periodic sound can be represented as a sum of sine-wave components.

Simple sounds are generally described in terms of three properties: frequency, amplitude, and phase. The frequency

of a sine wave is defined as the number of complete pressure cycles or repetitions in one second (CRef. 2.102). The amplitude of a sound wave can be specified as the height of the point of maximum pressure (P in Fig. 1) above static pressure (P_0) or as the height from the minimum pressure ($-P$) to maximum pressure (P) (CRef. 2.103). Phase refers to the position in the cycle of the sine wave at a particular point in time (CRef. 2.102). Phase is measured in angular units. One complete cycle (e.g., one pressure peak to the next pressure peak) equals 360 deg and one-half cycle equals 180 deg.

The time required for one entire pressure cycle to be completed and to begin over again is known as the period of the sound wave. The distance in space between one point of maximum pressure on the wave to the next point of maximum pressure (or between any point in the wave to the next point of corresponding phase) is the wavelength of the sound.

Resonance

Many objects, such as a tuning fork or a crystal glass, vibrate at a specific frequency when struck. This natural or resonant frequency of vibration is determined by the mass and stiffness of the object. A sound source with the same frequency as the natural frequency of an object can easily set it into vibration. This phenomenon is called resonance.

Resonance can also occur when some dimension of an object such as the length of a pipe or a room matches the wavelength of the sound.

—Adapted from Ref. 5

Constraints

- Sound shadowing, standing waves, echoes, sound absorption, and resonances may interfere with the propagation of sound.

Key References

1. Beranek, L. L. (1954). *Acoustics*. New York: McGraw-Hill.
 2. Marshall, G. (1982). *Safety-engineering*. Monterey, CA: Brooks/Cole Engineering Division.
 3. National Institute for Occupational Safety and Health (1978). *Industrial hygiene engineering and control, Vol. 4. Sound*. Cincinnati, OH: Division of Training and Manpower, National Institute for Occupational Safety and Health (NIOSH).
 4. Roederer, J. G. (1973). *Introduction to the physics and psycho-physics of music*. New York: Springer.
 5. Scharf, B., & Buus, S. (1986). Audition I: Stimulus, physiology, thresholds. In K. R. Boff, L. Kaufman, & J. P. Thomas (Eds.), *Handbook of perception and human performance: Vol. 1. Sensory processes and perception*. New York: Wiley.
 6. Schiffman, H. R. (1982). *Sensation and perception: An integrated approach*. NY: Wiley.

Cross References

- 2.102 Physical parameters and spectral analysis of sound;
 2.103 Measurement of sound amplitude

Table 1. Approximate speed of sound in different media. (From Ref. 2)

Medium	Speed (m/sec)
Dry air (20°C and 1 atmosphere)	344
(0°C and 1 atmosphere)	332
Lead	1228
Sea water	1540
Fresh water	1410
Wood	3050-4575
Glass	4728
Steel	5005
Aluminum	5106

2.102 Physical Parameters and Spectral Analysis of Sound

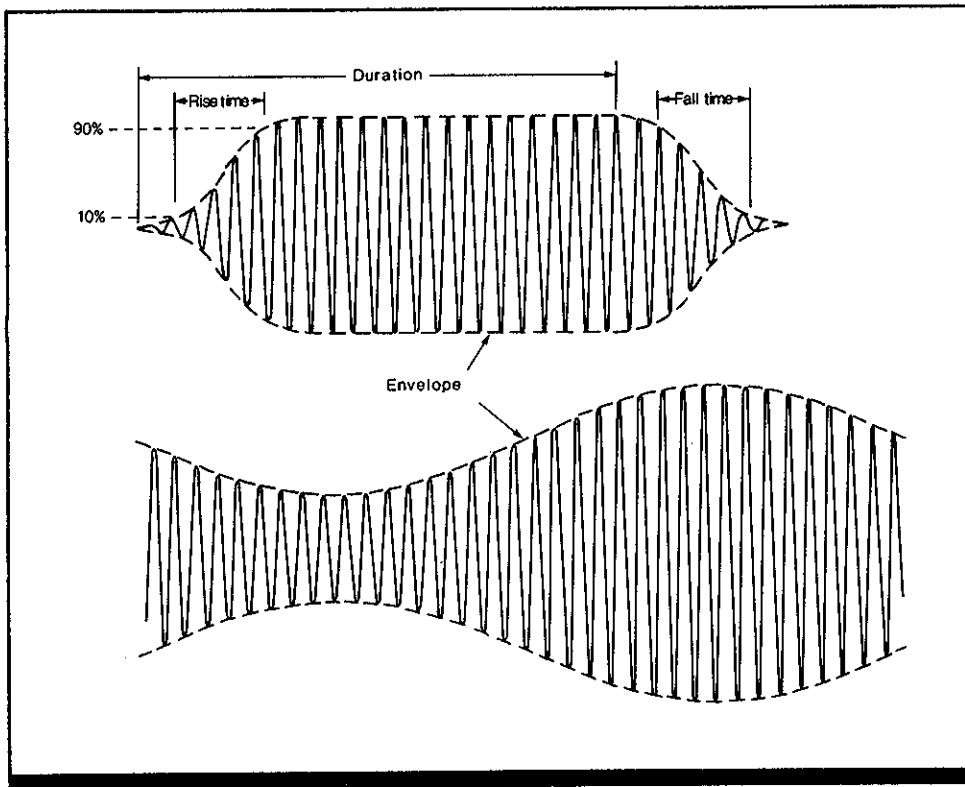

Figure 1. The waveform (solid line) and waveform envelope (dashed line) for a tone burst (top) and amplitude-modulated tone (bottom). (From *Handbook of perception and human performance*)

Key Words

Bandwidth; energy splatter; Fourier analysis; harmonics; overtones; spectral analysis; spectral distribution; waveform analysis

General Description

Three of the physical parameters of sound (frequency, waveform, and duration) are temporal characteristics; two other important physical characteristics are amplitude (expressed in terms of pressure) and phase relations. A pure tone, which is the most simple sound, is a sinusoidal pressure change transmitted through a medium (e.g., air). The frequency of the sinusoid is the number of repetitions of a cycle in one second (hertz = 1 cycle/sec), which is inversely proportional to the period T of the sound ($f = 1/T$), the duration of a cycle, and the wavelength (which is the distance between two peaks of the sinusoid). The frequency of a wave is associated with the subjective experience of pitch.

The waveform of a sound is the sound pressure of the wave plotted as a function of time (the solid line in Fig. 1). The waveform envelope may be described as the curve connecting successive peaks in the waveform (the dashed line in Fig. 1); rise time is the duration of the envelope's increase from 10 to 90% of its maximal value, and fall time is the duration of the envelope's decrease from 90 to 10% of its maximal value. The duration of sound is the time between the onset of the sound and the beginning of its offset (Fig. 1).

Signals with short durations (e.g., tone pips or clicks) have a greater energy range (called energy splatter) than signals with long durations. Energy splatter also occurs in the transitions from onset to steady-state amplitude and from steady-state to offset. The more abruptly a waveform changes, the wider its bandwidth (i.e., the greater its splatter).

Complex waves (Fig. 2a) are comprised of multiple sine waves. If a complex wave is repetitive, it is called periodic and the repetition rate is the fundamental frequency. Any complex wave can be described as the sum of perhaps an infinite number of component sine waves, which are integral multiples ($n > 1$) of the **fundamental frequency** and are called harmonics or overtones (Fig. 2b). The harmonic number of a frequency is the ratio of that frequency to the fundamental, and the number of an overtone is the harmonic number minus one. Musical instruments produce fundamental frequencies between 50-5000 Hz, depending on the note played (Fig. 3). The fundamental frequency of the average adult male's voice is 200 Hz, and the adult female's is about twice that. Much higher fundamentals may be produced by a voice under stress or by singing.

Waveform is associated with the subjective experience

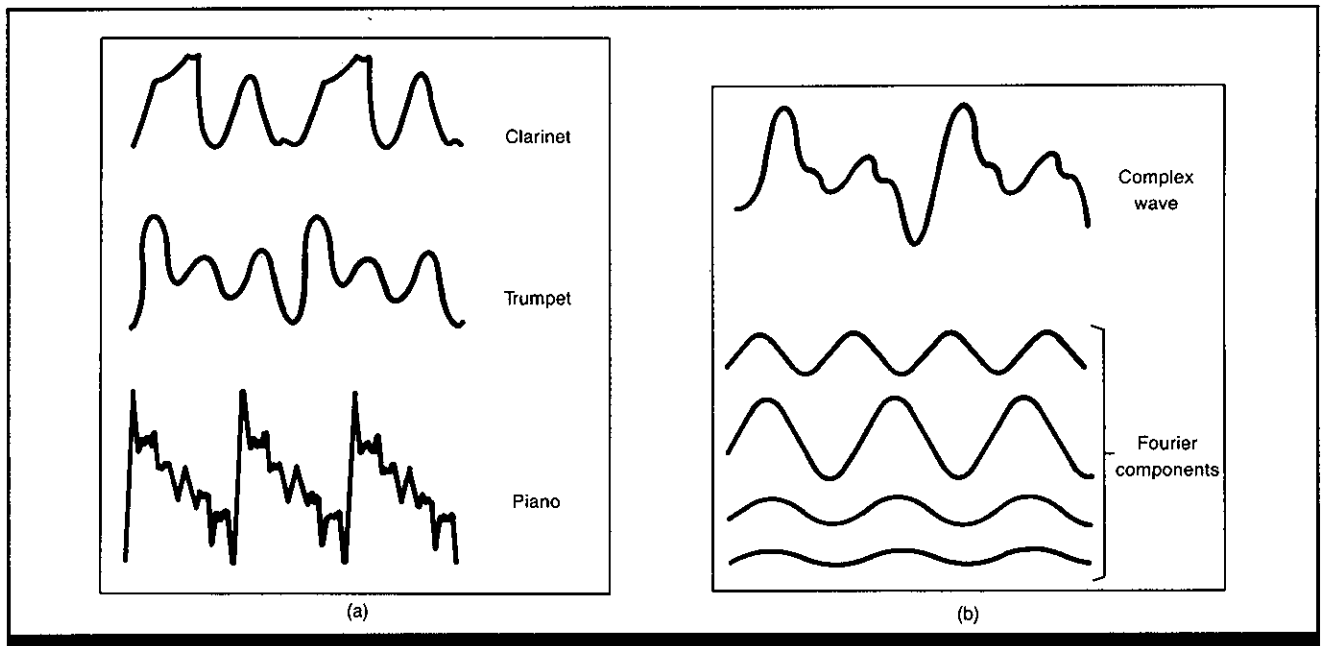

Figure 2. (a) Complex waveforms produced by three different musical instruments, each of which could be expressed as a sum of multiple component sine waves as in (b). (From Ref. 1)

of tonal quality (timbre). Examples of several different types of ideal waveforms are shown in Fig. 4: (a) a sinusoidal wave (a pure tone); (b) a sawtooth waveform; (c) a triangular waveform; (d) a rectangular waveform; and (e) **white noise**. Sawtooth waves contain all harmonics of the fundamental frequency with each harmonic present in proportion to the reciprocal of its harmonic number; triangular waveforms contain only odd harmonics with each harmonic present in proportion to the reciprocal of the square of its harmonic number.

Examples of phase relations are shown in Fig. 5. Waves can either be in phase (they have identical phase angles as in Fig. 6), perfectly out of phase (their phase angles differ by 180 deg as in Fig. 5), or somewhere in between (e.g., their phase angles differ by 90 deg as in Fig. 5). Phase is also expressed in radians; for example, 90 deg = $\pi/2$ radians and 180 deg = π radians. The formula for phase measurement

is $2\pi f\Delta t$ radians = 360 deg $f\Delta t$, where f is frequency and Δt is the time between the reference event (e.g., the peak) and the positive-going zero crossing of the sinusoid.

Any waveform can be completely described by its amplitude spectrum and its phase spectrum, which respectively plot amplitude and phase as functions of component frequencies. Several amplitude spectra are shown in Fig. 6. Line spectra (top two panels) for periodic sounds (e.g., complex tones) show the amplitude at each discrete frequency, while continuous spectra (e.g., for noise or speech) show an energy distribution across a range of frequencies (bottom three panels).

A phase spectrum of a complex sound is a plot of phase angles, each of which are the angular separation between a wave at reference time 0 and the nearest positive peak of the same wave. Phase angles (the y-axis) range from +180 to -180 deg (a complete cycle covers 360 deg). The

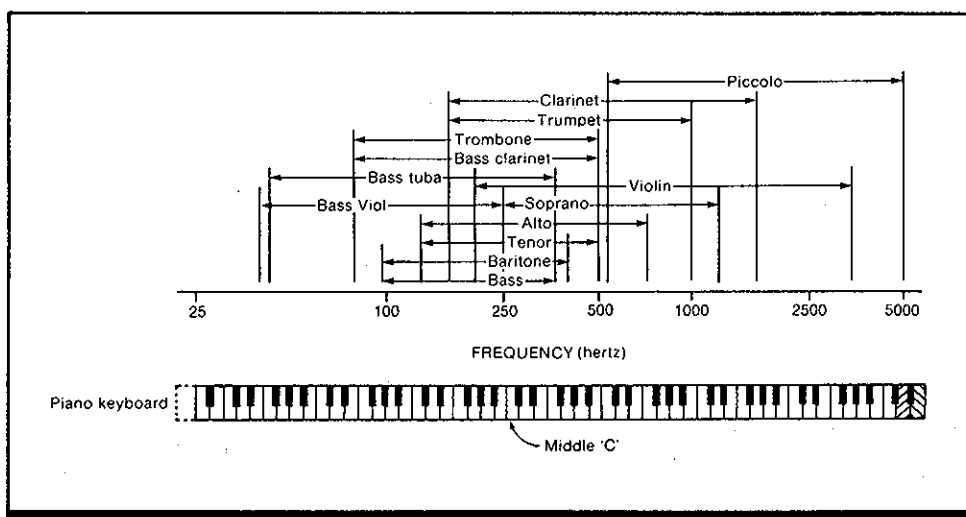

Figure 3. Range of fundamental frequencies produced by musical instruments and singing voices. (From Ref. 2)

2.1 Measurement of Sound

x-axis is identical to the x-axis of the amplitude spectrum for the same sound.

A Fourier transformation converts a waveform into a spectrum of its simple harmonic components. The spectrum of a periodic sound with period T consists of lines (some of which may have zero amplitude) with frequency spacing $1/T$. Because the Fourier transform requires an infinite in-

terval, its application is only an approximation. Short-term spectra are useful because the ear integrates sound over a short period (< 500 msec). For short-term spectra, the lines have a bandwidth that encompasses a frequency region (as opposed to infinitesimal width). Long-term spectra are a result of long-duration approximations; as the duration is lengthened, the approximation becomes more accurate.

Key References

*1. Coren, S., Porac, C., & Ward, L. M. (1984). *Sensation and perception*. New York: Academic Press.

2. Knudson, V. O., & Harris, C. M. (1980). *Acoustical designing in architecture*. New York: Acoustical Society of America. (Originally published, 1950).

Cross References

2.101 Sound propagation;
2.103 Measurement of sound amplitude;

2.313 Auditory sensitivity in noise: interaural masking;
Handbook of perception and human performance, Ch. 14, Sect. 1.2

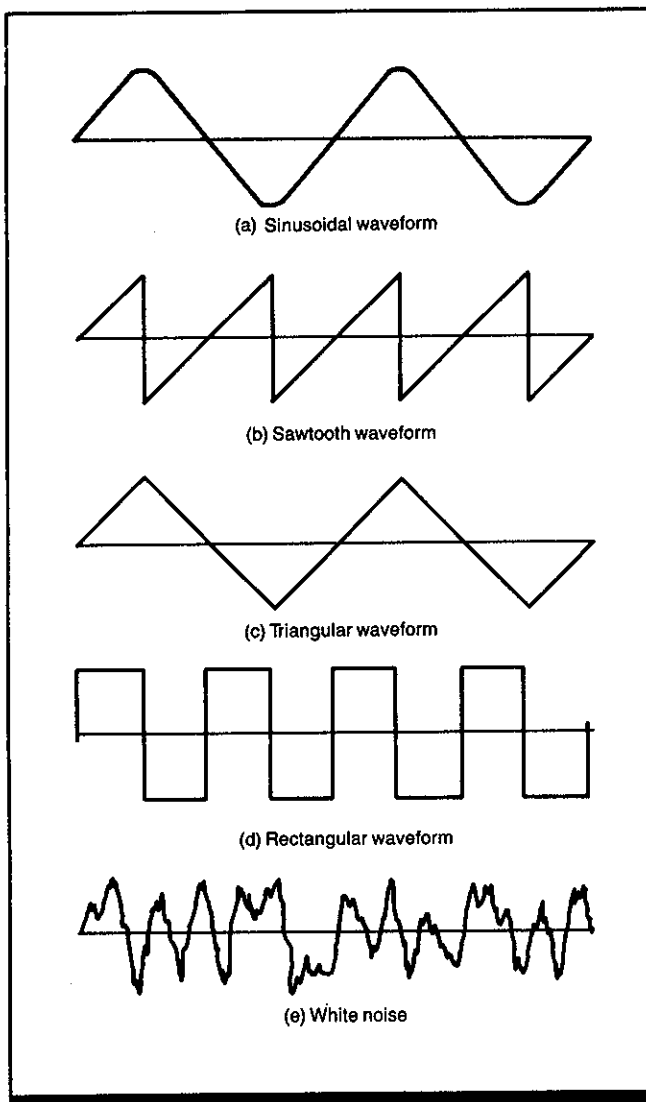

Figure 4. Examples of five ideal waveforms that produce different tonal qualities (sound timbre): (a) sinusoidal, (b) sawtooth, (c) triangular, (d) variable pulse, and (e) white noise.

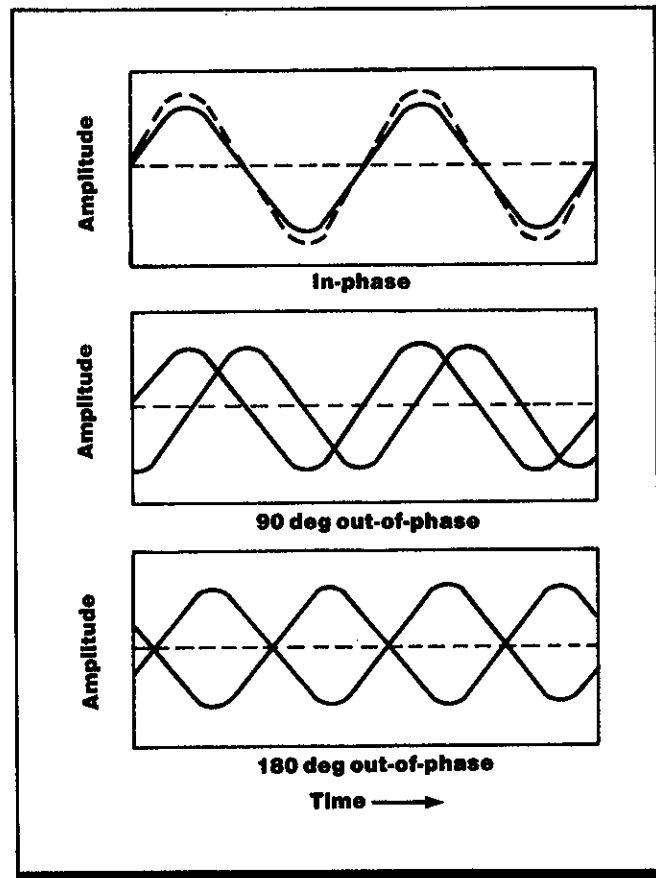

Figure 5. Three possible phase relations of two sine waves with the same frequency; in phase, 90 deg ($\pi/2$ radians) out of phase, and 180 deg (π radians) out of phase.

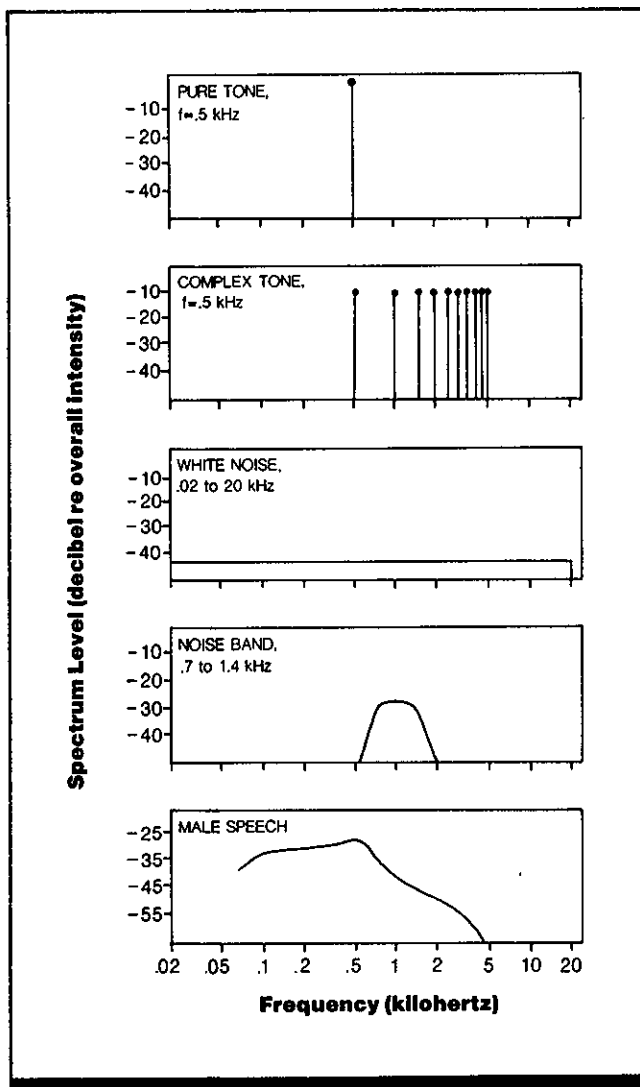

Figure 6. Amplitude spectra for (from top to bottom) a 500-Hz pure tone, a complex tone with 500-Hz fundamental frequency, 20000-Hz-wide white noise, noise with bandwidth 700-1400 Hz, and a long-duration average of male speech. (From *Handbook of perception and human performance*)

2.103 Measurement of Sound Amplitude

SOUND INTENSITY (W/m ²)	SOUND PRESSURE (dynes/cm ²)	SOUND PRESSURE (μ Pa)	SOUND PRESSURE LEVEL (dB SPL)	
10 ¹⁰	2 x 10 ⁷	20 x 10 ¹⁷	220	12" cannon, 4 m in front and below muzzle
			210	
10 ⁸	2 x 10 ⁶	20 x 10 ¹⁰	200	(Equivalent normal atmospheric pressure)
			190	
10 ⁶	2 x 10 ⁵	20 x 10 ⁹	180	
			170	
10 ⁴	2 x 10 ⁴	20 x 10 ⁸	160	
			150	
100	2000	20 x 10 ⁷	140	
10	630	63 x 10 ⁶	130	
1	200	20 x 10 ⁶	120	Threshold of pain
10 ⁻¹	63	63 x 10 ⁵	110	Rock band or loud discoteque
10 ⁻²	20	20 x 10 ⁵	100	Hammering on steel, 1 m
10 ⁻³	6.3	63 x 10 ⁴	90	Subway station, express passing
10 ⁻⁴	2	20 x 10 ⁴	80	Electric power station
10 ⁻⁵	0.63	63 x 10 ³	70	Average factory
10 ⁻⁶	0.2	20 x 10 ³	60	Very loud radio in home
10 ⁻⁷	0.063	63 x 10 ²	50	Ordinary conversation, 1 m
10 ⁻⁸	0.02	20 x 10 ²	40	Department store, noisy office
10 ⁻⁹	0.0063	630	30	Quiet residential street
10 ⁻¹⁰	0.002	200	20	Average residence
10 ⁻¹¹	0.00063	63	10	Quiet whisper, 1.5 m
10 ⁻¹²	0.0002	20	0	Out of door minimum
				Threshold of audibility

Figure 1. Sound intensity, sound pressure, and sound pressure level (dB re 20 μPa or 0.0002 dynes/cm²) compared for some familiar sounds. (From Ref. 5)

Key Terms

Auditory sensitivity; decibel; inverse square law; sensation level; sound intensity; sound measurement

General Description

Sound Pressure

Although sound can be considered in terms of particle velocity or particle displacement, in studying human hearing it is usually most convenient to consider sound as a change in pressure. Sound pressure can be expressed in many different units, but the presently preferred unit for sound pressure is the micropascal ($\mu\text{Pa} = 10^{-6} \text{ N/m}^2 = 10^{-6} \text{ kg/m/sec}^2$), which is useful for expressing the very small pressure changes encountered in acoustics. Other units are dynes per square centimeter and microbars. Both 1 dyne/cm^2 and $1 \mu\text{bar}$ are equal to $10^5 \mu\text{Pa}$.

Sound pressure is usually measured as the root-mean-square (RMS) value of the pressure deviation from the static pressure. The RMS value is the square root of the mean (over some time interval) of the squared instantaneous deviations. Peak sound pressure and peak-to-peak sound pressure are also useful to describe some aspects of sound. The peak sound pressure is the highest sound pressure encountered during the measurement interval. The peak-to-peak sound pressure is the difference between the highest and the lowest (most negative) sound pressure encountered during the measurement interval. For a **sine wave**, the peak sound pressure is $\sqrt{2}$ times higher than the RMS sound pressure and the peak-to-peak sound pressure is twice the peak pressure. The crest factor of a sound is the ratio of the peak sound pressure to the RMS sound pressure.

Intensity

When combining sounds of different frequencies, the total sound power equals the sum of the powers of each individual sound. For this reason, it is often practical to measure the strength of a sound in terms of power. To limit the measurement to a specific place (e.g., at the center of a listener's head), the sound is not measured by its total power, but rather in terms of intensity, which is a measure of power flow per unit area. The unit for intensity is watts per square meter (W/m^2). The RMS sound pressure and the intensity of a sound are closely related; for a plane sound wave

$$I = \frac{p^2}{\rho c} \quad (1)$$

where I is the intensity, p is the RMS sound pressure, ρ is the density of the medium, and c is the speed of sound (for air at atmospheric pressure and standard temperature of 20°C , $\rho c \approx 410 \text{ N sec/m}^3$). A *plane sound wave* can be assumed when the distance to the sound source exceeds a few wavelengths and reflections are absent.

The Inverse Square Law

The area over which the intensity of a sound is measured can be regarded as a small part of the surface of a sphere whose center is at the sound source. If the distance to the sound source is doubled, the power flowing through the measurement area will be spread out over an area four times as large. Consequently, the intensity of the sound will be one-fourth. In general, the intensity is inversely proportional to the square of the distance. The law is the *inverse*

square law. In a plane sound field the intensity is proportional to the square of the sound pressure; hence sound pressure is inversely proportional to the distance.

Level: The Decibel Scale

The range of sound pressures that can be heard exceeds $1:10^6$ and the range of intensities exceeds $1:10^{12}$. It is therefore convenient to express sound pressure and intensity as *level* on a logarithmic scale. A special scale, the *decibel* (dB) scale, is used almost universally in acoustics. The *intensity level*, L , of a sound is defined as follows:

$$L = 10 \log \left(\frac{I}{I_0} \right) \text{ dB} \quad (2)$$

where I is the intensity of the sound and I_0 is an arbitrarily chosen reference intensity. If the intensity of sound A is chosen as reference (I_0), and the intensity of sound B is I , the equation yields the level difference in decibels between A and B . It is usually desirable to express the intensity of a sound relative to a *standard reference intensity* of 10^{-12} W/m^2 . This standard intensity is close to the threshold of audibility for a 1,000-Hz tone.

The *sound pressure* can be derived from Eqs. (1) and (2) as:

$$L = 20 \log \left(\frac{p}{p_0} \right) \text{ dB}, \quad (3)$$

where p is the RMS pressure of the sound and p_0 is the pressure of the reference sound. In air, the standard reference sound pressure corresponding to $I_0 = 10^{-12} \text{ W/m}^2$ is $p_0 = 20 \mu\text{Pa}$. When the level of a sound is expressed relative to $20 \mu\text{Pa}$ (0.0002 dyne/cm^2) it is referred to as *sound pressure level* (SPL) which is always expressed in decibels. In air, the SPL of a sound is equal to the intensity level of the sound, provided the reference intensity equals 10^{-12} W/m^2 .

Figure 1 shows the relation between intensity, sound pressure, and SPL and indicates where some familiar sounds would fall on the scale. The levels that are usually considered in studies of human hearing range from a little below 0 dB SPL to somewhat above 100 dB SPL.

The distinction between intensity level and sound pressure level is often blurred, although it is important when calculating the total level of a combination of sounds.

Sensation Level, Hearing Level, and Hearing Threshold Level

Sound level is always a relative measure, that is, the ratio between the sound in question and some reference sound. The level is meaningful only when the reference is stated. The level in dB SPL is always relative to $20 \mu\text{Pa}$, but this is not the only reference that may be used. In many hearing experiments, the level is expressed relative to the listener's threshold for the sound. The level in decibels above a listener's threshold is the *sensation level* (dB SL). The listener's threshold for the sound (the sound pressure, p_{TH} , at which he can just hear the sound) is first measured, and the level of sound is calculated with p_{TH} as the reference sound pressure.

2.1 Measurement of Sound

Another commonly used reference is the average threshold of normal listeners as codified in national and international standards (Ref. 1, 2). The level relative to such a standard threshold is the hearing level (HL) or hearing threshold level (HTL). The intensity of a sound at a given

SL depends on the frequency, the sound source, and the listener. The intensity of a sound at a given HTL depends only on the frequency and the sound source.

—Adapted from Ref. 5

Constraints

- The inverse square law holds only for sound in a **free field**, i.e., with no interfering objects to reflect or absorb sound; while such conditions may be duplicated to a good approximation in specially designed laboratories, they virtually never occur in the normal environment.

Key References

1. American National Standards Institute (1969). *American national standard specifications for audiometers*, 53.6. New York: ANSI.
2. International Standards Organi-

zation (1975). *Standard reference zero for the calibration of pure-tone audiometers*, 389. New York: ISO.

3. Olishifski, J. B. (1979). *Fundamentals of industrial hygiene* (2nd Ed.). Chicago, IL: National Safety Council.

4. Roederer, J. G. (1973). *Introduction to the physics and psycho-physics of music*. New York: Springer.

- *5. Scharf, B., & Buus, S. (1986). *Audition I: Stimulus, physiology,*

thresholds. In K. R. Boff, L. Kaufman, & J. P. Thomas (Eds.). *Handbook of perception and human performance: Vol. I. Sensory processes and perception*. New York: Wiley.

Cross References

- 2.101 Sound propagation;
- 2.104 Calibration procedures and instruments for measuring sound

Notes

2.104 Calibration Procedures and Instruments for Measuring Sound

Key Terms

Acoustic coupler; dosimeter; headphone; microphone; sound intensity; sound measurement; spectral analysis

General Description

Direct calibration of an auditory stimulus requires the measurement of the acoustic spectrum in some well-specified location. However, direct acoustic measurements are somewhat difficult and time consuming. Therefore, calibration usually is done on the electric wave form that drives the electroacoustic transducer (loudspeaker or headphone). This electrical calibration is less rigorous than acoustic calibration because it assumes that the acoustic output of the transducer is specified exactly for a given electrical input and remains stable over time. Whether the calibration measurements are made on the acoustical or the electrical wave form, at some point they involve electrical wave forms, because the acoustic wave forms almost always are converted into electrical wave forms by means of a microphone.

Calibration Microphones

To be useful for calibration, the electrical output voltage of the microphone must be specified exactly for any given acoustical input. Although the conversion of acoustical wave forms into electrical wave forms can be achieved in many different ways, calibration measurements are made almost exclusively with condenser microphones. The condenser microphone is preferred because its conversion characteristics are relatively stable. Moreover, its frequency response, which is its electrical output as a function of frequency when the SPL is kept constant, is flatter than that of most other types of microphones.

To make measurements where the microphone itself does not fit, such as in the ear canal, or is so large that it disturbs the sound field, a probe microphone is often used. This is a microphone with a thin metal or plastic tube (the probe) attached to it. The resonances of the tube alter radically the frequency characteristic of the microphone. The resonant peaks and valleys can be made smaller and broader by damping the probe with sound-absorbing material.

The probe and microphone must be calibrated together as a unit to yield useful measurements. Calibration is typically done by measuring the output of the probe microphone in response to a constant sound pressure generated in a small enclosure such as an acoustic coupler. However, the acoustical characteristics of the coupler can change the measured frequency response of the probe microphone by a substantial amount in some frequency ranges. Therefore, calibration should preferably be made in an acoustical environment that is similar to the environment in which the measurements are to be made.

Voltmeters and Sound Level Meters

The level of a sound is usually measured with a *voltmeter*. Most voltmeters measure the RMS voltage of the wave form, but may also measure peak or peak-to-peak voltage. The precision of voltmeters is quite good; often their accu-

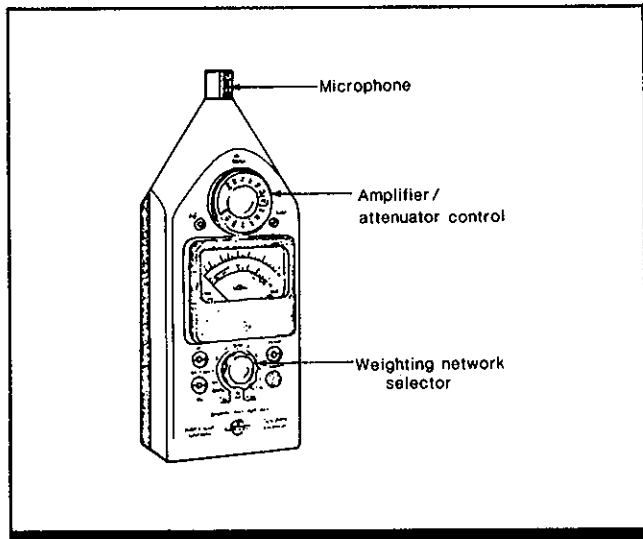

Figure 1. Sound level meter. A sound level meter consists of a microphone (top), an amplifier and attenuator (below microphone), weighting networks selected by the knob at the bottom, and a meter calibrated in dB SPL (middle). Newer models are based on the same general principles but frequently incorporate digital readouts. (Courtesy Bruel & Kjaer Instruments, Inc., 1970)

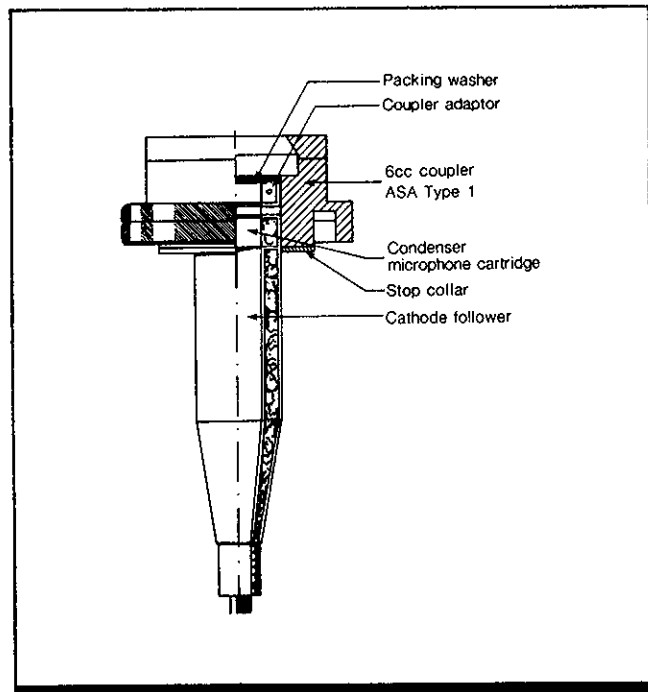

Figure 2. Coupler for earphone calibration. An ASA Type 1 (NBS-9A) coupler, mounted on a condenser microphone and cathode follower, is shown in cross section. The coupler provides a rough approximation of the acoustical impedance of an average human ear by means of its 6 cm³ volume. Newer models are similar. (Courtesy Bruel & Kjaer Instruments, Inc., 1961)

racy is within $\pm 2\%$ corresponding to ± 0.2 dB. From the frequency response of the measuring microphone, the voltage is easily translated into SPL. In fact, the voltmeter may be calibrated for use with a specific microphone and the SPL read directly from the instrument. The combination of a microphone and a voltmeter calibrated in SPL is called a *sound level meter* (see Fig. 1). The accuracy of sound level meters is usually less than that of voltmeters, owing to the characteristics of the microphone, but can be within ± 0.5 dB at a specified frequency and within ± 1 dB over most of the audible frequency range.

Many sound level meters have weighting networks that emphasize some frequencies and attenuate others. These weighting networks (designated A, B, and C) provide objective, weighted measurements of noise levels that are meant to correspond more closely to their subjective effects than unweighted measurements. Normally, the SPL specified in psychoacoustics is the unweighted SPL. The weighted sound pressure level is often called *sound level* and is stated with the weighting network indicated in parentheses after the measured sound level, such as 65 dB (A). The weighting networks are standard filters whose frequency responses approximate the pure-tone equal-loudness contours with loudness levels between 30 and 60 phons for the A weighting, between 60 and 90 phons for the B weighting, and above 90 phons for the C weighting. (The loudness level in *phons* is the SPL of a 1-kHz tone that is judged equally loud to the test sound.) In principle, these weighting networks should yield values that correspond to the loudness level of a single pure tone at any frequency; they are not expected to yield values that correspond to the loudness level of complex sounds due to the increased loudness of wide-band sounds. However, even for tones the weighted level only approximates the loudness level, because the weighting curves were chosen with as much attention to the ease by which they could be implemented electronically as to their agreement with equal-loudness measurements.

A noise dosimeter measures the total sound level a person is exposed to over one day. It is worn by the individual and accumulates a record of noise energy. Sudden bursts of noise can be measured by an impact sound level meter or impulse meter that records a level somewhat below the peak intensity.

Calibration in Free Field

The method used to calibrate the level of a sound depends

on the sound source and the listening environment. If the sound source is a loudspeaker, level is customarily measured at the location corresponding to the center of the listener's head. Thus the level is measured without disturbance of the sound field by the presence of the listener. If necessary, the disturbance caused by the microphone or sound level meter should be taken into account. Special freefield microphones, whose frequency response is corrected to compensate for their disturbance of the sound field, are available.

Calibration of Headphones

Calibration of the acoustical wave form produced by a headphone is usually performed by means of an *acoustic coupler* such as that shown in Fig. 2. The coupler provides a standard connection between headphone and microphone. The microphone should have a pressure response that changes little as a function of frequency up to 15-20 kHz. The acoustic coupler is sometimes called an *artificial ear*, because it is designed to provide an acoustical environment like that of the average human ear. Because this resemblance is restricted at best to a very narrow frequency range and only for some commonly used audiometric headphones, and because the geometry of standardized acoustic couplers is different from that of an ear, the SPL produced by a headphone in a coupler cannot be simply related to either the SPL in a real ear, or SPL in a free field. It does, however, provide a reproducible, standardized calibration that permits comparison of results from different laboratories.

Spectrum Analyzers

The instruments just discussed permit calibration of the overall SPL and, if it is periodic, the frequency of a sound. However, they do not provide information about spectrum. The amplitude spectrum of a wave form may be measured with a spectrum analyzer or wave analyzer. Most *spectrum analyzers* measure amplitude of a narrow band of frequencies by passing the signal through a sharply tuned filter. The center frequency of this filter may be swept across the audible frequency range to measure spectrum level at different frequencies, which in turn may be displayed graphically. Recently, analyzers performing a Fourier transformation on the wave form have become available. These *FFT-analyzers* (fast Fourier transformation) use computer technology to specify quickly and conveniently the precise amplitude spectrum of wave forms.

—Adapted from Ref. 3

Constraints

- The indicator needle or readout dial of a meter cannot follow very rapidly changing variations in sound level and thus averages the level, with integration time determined by the meter characteristics.

- Measurement of sound is affected by objects and people in the area (e.g., absorption and echoes), and thus may change with different microphone locations.
- Measuring equipment itself must be calibrated before use.

Key References

1. Marshall, G. (1982). *Safety engineering*. Monterey, CA: Brooks/Cole.
2. Olishifski, J. B. (1979). *Fundamentals of industrial hygiene*, (2nd

Ed.), Chicago, IL: National Safety Council.

- *3. Scharf, B. & Buus, S. (1986). Audition I: Stimulus, physiology, thresholds. In K. R. Boff, L. Kaufman, & J. P. Thomas (Eds.), *Handbook of perception and*

human performance: Vol. 1. Sensory processes and perception. New York: Wiley.

4. Shaw, E. A. G. (1965). Earcanal pressure generated by a free field sound. *Journal of the Acoustical Society of America*, 39, 365-470.

5. Shaw, E. A. G. (1965). Earcanal pressure generated by circumaural and supraural earphones. *Journal of the Acoustical Society of America*, 39, 471-479.

Cross References

2.103 Measurement of sound amplitude;

2.105 Noise and distortion;
2.602 Effect of sound pressure level on loudness

2.105 Noise and Distortion

Key Terms

Aural distortion; combination tone; harmonic distortion; intermodulation distortion; masking; noise; pink noise; white noise

General Description

In everyday usage, the word *noise* refers to sound with acoustic characteristics that are unwanted or sound that is deliberately introduced to interfere with the audibility of a signal. In auditory science, however, the term *noise* has a more precise meaning; it is the sound produced by pressure changes that are essentially random and unpredictable. The steady hissing of a radio tuned between stations is one example of such a sound. Table 1 lists several types of noise and indicates briefly how noise may be measured.

Nonlinearities in a sound transmission or sound reproduction system lead to distortion of the signal. One indication of distortion is the presence of audible tones, known as **combination tones**, at frequencies that were not present in the original signal. Nonlinearities in audio playback equipment, sound interaction with the room or headphones, and nonlinearities in the auditory system itself make it impossible to measure a response to a "pure signal." Distortion products may interfere with or enhance detectability of the signal. Table 1 lists several kinds of distortion and describes briefly how distortion may be measured.

Applications

Because noise or distortion is always present, it is important to be aware of its characteristics and effects when measuring auditory stimuli or assessing auditory performance.

Although noise is often undesirable, there are situations where addition of noise with specific characteristics may be useful. For example, if the listening environment permits leakage of conversation from another room, the addition of white noise can mask the leak. If there is constant noise from a machine, addition of lower frequency noise or white noise can mask the machine's noise or render it less distract-

ing by reducing the concentration of relative energy at the frequencies emitted by the machine so that energy levels are more equal throughout the entire audible spectrum. In auditory research, if the experimenter might hear the signal and inadvertently cue the subject, placing earphones with white-noise output on the experimenter may help.

To test for the presence of distortion products, an extra signal component is sometimes introduced which will interact with the distortion products if they are present. If an interaction sound (such as beats or combination tones) is detectable, then the distortion is verified.

Key References

1. Green, D. M. (1976). *An introduction to hearing*. New York: Wiley.

2. Roederer, J. G. (1973). *Introduction to the physics and psychophysics of music*. New York: Springer.

3. Scharf, B., & Houtsma, A. J. M. (1986). Audition II: Loudness, pitch, localization, aural distortion, pathology. In K. R. Boff, L. Kaufman, & J. P. Thomas (Eds.), *Handbook of perception and human performance: Vol. 1. Sensory processes and performance*. New York: Wiley.

Cross References

2.103 Measurement of sound amplitude;

2.306 Factors affecting auditory

sensitivity in the presence of masking noise;

10.301 Noise bursts: effect on task performance;

10.302 Continuous broadband noise: effect on task performance

Table 1. Types of noise and distortion.

Factor	Definition and Comments
Total harmonic distortion	Total harmonic distortion equals $100 \left(\frac{\sum_{n=2}^N A_n^2}{\sum_{n=1}^N A_n^2} \right)^{1/2}$ where A_n = amplitude of n th harmonic
Harmonic distortion	Arises from the effect of non-linearities on a sine wave signal, and is comprised of spectral components at frequencies that are integral multiples of the sine wave
Intermodulation distortion	Produces spectral components (combination tones) at frequencies that are the sum or difference of the input frequencies and their harmonics
Measurement of distortion	Measured as the difference in level (measured at output) between input frequencies and distortion components using the following formula (where A = amplitude): Distortion = $[A_{\text{overall}}^2 - (A_{\text{input}}^2/A_{\text{overall}}^2)]^{1/2}$ where A_{overall} = root mean square (RMS) value of the total signal at output and A_{input} = RMS value of input frequencies at output
White noise	The noise has equal power at all frequencies between the lower and upper cutoffs; usually has a broad bandwidth
Pink noise	The noise spectrum decreases at higher frequencies so that energy (power \times time) is equal in each octave band of frequencies
Equipment noise	Computed as signal-to-noise ratio (in decibels): $20 \log (v_s/v_n)$, where v_s = maximal or nominal signal voltage at output and v_n = noise voltage at output
Measurement of noise	In addition to the overall level of the noise, the <i>spectrum level</i> of the noise is frequently measured; the spectrum level, usually denoted N_0 , is the average noise power in a 1-Hz-wide band of the noise (the noise-power density)

2.201 Anatomy and Physiology of the Ear

Gross division	Outer ear	Middle ear	Inner ear	Central auditory nervous system
Anatomy				
Mode of operation	Air vibration	Mechanical vibration	Mechanical, hydrodynamic, electrochemical	Electrochemical
Function	Protection, amplification, localization	Impedance matching, selective oval window stimulation, pressure equalization	Filtering distribution, transduction	Information processing

Figure 1. The outer, middle, and inner portions of the ear, and their associated modes of operation and function. (From Ref. 1)

Key Terms

Auditory physiology; cochlea; inner ear; middle ear; outer ear; sound propagation

General Description

There are three major divisions of the ear, as shown in Fig. 1: the outer ear, which serves as a sound collector; the middle ear, which transforms low-force, high-amplitude vibrations into high-force, low-amplitude vibrations; and the inner ear, which changes mechanical vibrations into neural impulses.

The external ear extends from the visible portion outside the head (pinna or auricle) to the external acoustic (auditory) meatus, which forms the entrance to the auditory canal extending from the pinna to the tympanic membrane (or eardrum). In humans, the outer ear plays little part in sound modification. The resonance of the ear canal causes a slight improvement (~10 dB) in audibility of frequencies at ~3000 Hz, but the resonance is not sharp. The folds of the pinna modify sound intensities differently at different fre-

quencies, and these can provide cues to spatial localization in the absence of **binaural** cues (CRef. 2.810).

The sound pressure waves (air vibration) impinging on the ear are converted to mechanical forces in the middle ear. Three small bones, the ossicles (which include the malleus, the incus, and the stapes), connect the tympanic membrane to the membrane-covered opening (oval window) between the middle and the inner ears. The vibration of the tympanic membrane causes vibration of the ossicles, which in turn causes fluid vibration in the cochlea (inner ear). The difference in size of the tympanic membrane (~0.7 cm²) and the oval window (~0.3 cm²) causes the low-force, high-amplitude vibrations of the tympanic membrane to become high-force, low-amplitude vibrations at the oval window. The eustachian tube connects the middle-ear cavity with the nasopharynx and maintains environmental air pressure in the ear canal.

The spiral cochlea contains the Organ of Corti, which is supported by the basilar membrane and contains the hair cells. Hair cells are nerve receptors (transducers) that transform the mechanical vibrations that move the basilar membrane into electrical impulses in the sensory neurons of the eighth cranial nerve. There is a rough correspondence between sound frequency and the location of the hair cells giv-

ing maximum responses: high frequencies cause maximum response near the oval window and low frequencies cause maximum response at the apex of the cochlea (farthest away from the oval window). The round window, which is located directly below the oval window, dissipates the fluid vibrations that disturbed the hair cells.

Key References

1. Ades, H. W., & Engström, H. (1974). Anatomy of the inner ear. In W. D. Keidel & W. D. Neff (Eds.), *Handbook of sensory physiology: Vol. VII. Auditory system: Anatomy, physiology (ear)* (pp. 125-158). Berlin: Springer-Verlag.
 2. Békésy, G. von, & Rosenblith, W. A. (1951). The mechanical properties of the ear. In S. S. Stevens (Ed.), *Handbook of experimental psychology*. New York: Wiley.
 3. Scharf, B., & Buus, S. (1986). Audition I: Stimulus, physiology, thresholds. In K. R. Boff, L. Kaufman, & J. P. Thomas (Eds.), *Handbook of perception and human performance: Vol. 1. Sensory processes and performance*. New York: Wiley.
 4. Schiffman, H. R. (1982). *Sensation and perception: An integrated approach*. New York: Wiley.
-

Cross References

- 2.202 Acoustic reflex;
- 2.810 Localization in the median plane

2.202 Acoustic Reflex

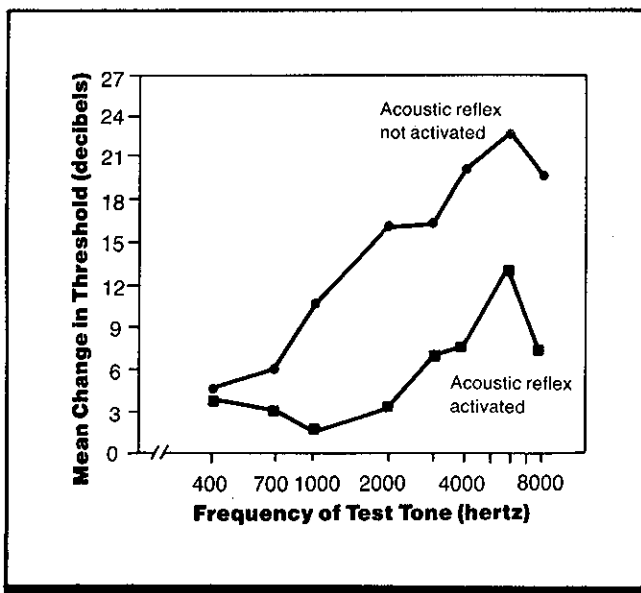

Figure 1. Hearing loss (temporary threshold shift) after exposure to machine-gun fire. The graph shows the difference in pre- and post-exposure thresholds for tones of eight different frequencies. The lower curve is from sessions in which the acoustic reflex was activated by presenting a loud tone prior to the gunfire; the upper curve is from sessions in which the acoustic reflex was not activated. Data are averages for 34 male subjects. (From Ref. 1)

Key Terms

Acoustic reflex; middle ear; sound intensity; stapedius muscle; temporary threshold shift (TTS)

General Description

The acoustic reflex is a contraction of the stapedius muscle attached to the stapes, one of the sound-conducting bones of the middle ear (CRef. 2.201), in response to high-intensity sounds. The acoustic reflex attenuates sound by making the eardrum and the conducting bones of the middle ear difficult to move and thus protects the inner ear from damage due to

intense sounds. The reflex also decreases low-frequency masking of high-frequency sounds. Table 1 lists the characteristics and effects of the acoustic reflex. Figure 1 illustrates a reduced temporary hearing loss (measured by threshold shift after 100 rounds of 0.30 caliber machine gun) attributed to exposure to 1000 Hz, 98 dB (SPL) tone for 200 msec prior to and during firing.

Applications

The acoustic reflex, activated by a pre-impact warning sound, can be used to alleviate temporary or permanent hearing loss from impulse sounds such as explosions, drop hammers, or gunfire.

Constraints

- Acoustic reflex activation is dependent upon sound quality and environmental conditions.
- There are large individual differences in the threshold for activating the acoustic reflex.

- The acoustic reflex can also be activated by some voluntary or involuntary facial muscle movements.
- Pre-activation of reflex is necessary for protection, because the interval before the onset of contraction after a high-intensity, brief sound is too long.

Key References

1. Fletcher, J. L., & Riopelle, A. J. (1960). Protective effect of the acoustic reflex for impulsive noises. *Journal of the Acoustical Society of America*, 32, 401-404.

2. Flottorp, G., Djupesland, G., & Winther, F. (1971). The acoustic stapedius reflex in relation to critical bandwidth. *Journal of the Acoustical Society of America*, 49, 457-461.

*3. Møller, A. R. (1974). The acoustic middle ear muscle reflex. In W. D. Keidel, & W. D. Neff (Eds.), *Handbook of sensory physiology: Vol. VII. Auditory system anatomy and physiology* (pp. 519-548). Berlin: Springer-Verlag.

Cross References

- 2.201 Anatomy and physiology of the ear;
10.315 Factors affecting noise-induced permanent threshold shift

Table 1. Characteristics and effects of the acoustic reflex.

Factor	Effect	References
Thresholds for triggering reflex	For pure tones of 250-4000 Hz, the reflex is triggered by tone bursts of at least 500 msec duration at ~70-75 dB above threshold to same ear in which reflex is measured. The contraction threshold is ~5 dB greater for the opposite ear and ~3 dB less when the triggering tone is presented binaurally .	Refs. 1, 3
	Minimum intensity for triggering the reflex is lower for complex sounds (noise) than for pure tones.	Ref. 3
	Trigger thresholds for speech sounds presented via earphones are approximately the same as for a 500-msec, 500-Hz tone.	Ref. 3; CRef. 10.315
Sound duration	Decreases in stimulus duration lead to increases in reflex contraction thresholds.	Ref. 3
Reflex latency	Latency from sound onset to beginning of reflex response is ~150 msec for sounds near threshold and 25-35 msec for loud sounds.	Ref. 3
Stimulus bandwidth	For noise bands and complex tone stimuli, at a given center frequency, trigger threshold for the reflex is constant, regardless of stimulus bandwidth, until a certain bandwidth (critical band) is exceeded; size of the critical band and threshold values for triggering the reflex vary with center frequency.	Ref. 2
	For noise bands wider than the critical band, there is ~3-6 dB decrease in threshold per octave increase in bandwidth.	Ref. 2
	For center frequencies of 1000-4000 Hz, the critical band, as measured by the acoustic reflex, is larger than the critical band measured by psychophysical methods by a factor of 3.	Ref. 2
Masking effects	Reflex decreases low-frequency masking of high-frequency sounds.	Ref. 3
Protective effects	Reflex is least effective for sounds that vary rapidly in intensity.	Ref. 3
	Exposure to a 1000-Hz tone for 200 msec prior to and during the firing of a 0.30-caliber machine-gun round reduced temporary hearing loss (measured by threshold shift after 100 rounds were fired) as shown in Fig. 1.	Ref. 1

2.301 Factors Affecting Auditory Sensitivity in Quiet

Key Terms

Auditory detection; auditory masking; auditory sensitivity; frequency; noise exposure; noise-induced permanent threshold shift; presbycusis; stimulus duration; temporary threshold shift (TTS)

General Description

The sound pressure level necessary to detect a sound depends on acoustic characteristics of the sound, acoustic characteristics of other sounds presented near it in time, the age and previous noise exposure of the listener, and the me-

dium through which the sound is presented. The table lists a number of specific factors that affect hearing thresholds, indicates the nature of the effect, and cites sources of more information.

Constraints

- Hearing thresholds may differ depending on the method used to measure performance.
- Hearing threshold may improve with practice.

Factor	Effect	References
Medium of sound transmission	Absolute thresholds are greater underwater than in air, particularly at high frequencies.	Ref. 2; CRef. 2.304
Frequency	Thresholds for pure tones are highest at low frequencies (<1000 Hz), decrease up to 4000 Hz, and then rise again.	Ref. 1; CRef. 2.302
Free field versus earphone presentation	Free-field thresholds are lower than earphone thresholds for signals <6000 Hz and higher for signals >6000 Hz.	CRef. 2.302
Binaural versus monaural listening	Binaural thresholds are ~3 dB lower than monaural thresholds, independent of frequency.	CRef. 2.305
Signal duration	As signal duration decreases from 200 msec, signal intensity must be doubled every time duration is halved. Threshold is constant above 200 msec, but constant signals near threshold become inaudible if they remain on for >10-20 sec.	
Bandwidth of multitone complexes	Threshold of multitone complexes is constant regardless of frequency separation of components provided all components fall within the same critical band ; threshold is raised when components are not within critical band.	CRef. 2.310
Masking	A masking stimulus raises the threshold for the signal when the mask is presented within the critical band of the signal and within 100 msec of the signal. Narrowing the mask to less than the critical band reduces the masking effect, but broadening it beyond a critical band normally does not increase threshold. The mask affects high-frequency targets more than low.	CRefs. 2.306, 2.307
Age	Thresholds increase from young adulthood to old age, particularly for high-frequency sounds. Age related hearing loss presbycusis has been claimed to be greater for men than for women, but this appears to be due exclusively to amount of noise exposure.	Refs. 4, 6; CRef. 2.303
Noise exposure Temporary threshold shift	Thresholds increase in proportion to duration and intensity of noise exposure, but gradually return to preexposure values after the noise is turned off.	Ref. 7; CRef. 10.311
Noise-induced permanent threshold shift	Permanent hearing loss is proportional to intensity and number of years of exposure.	Ref. 7; CRef. 10.311

Key References

1. Berger, E. H. (1981). Re-examination of the low- frequency (50-1000 Hz) normal threshold of hearing in free and diffuse sound fields. *Journal of the Acoustical Society America*, 70, 1635-1645.
2. Brandt, J. F., & Hollien, H. (1967). Underwater hearing thresholds in man. *Journal of the Acoustical Society of America*, 42, 966-971.
3. Chocolle, R. (1954). Etude statistique des seuils auditifs monauraux et binauraux. Interprétation des résultants. *Acustica*, 4, 341-350.
4. Corso, J. F. (1963). Age and sex differences in puretone thresholds. *Archives of Otolaryngology*, 77, 385-405.
5. Gässler, G. (1954). Über die Hörschwelle für Schallereignisse mit verschieden breitem Frequenzspektrum. *Acustica*, 4, 408-414.
6. Hinchcliffe, R. (1959). The threshold of hearing as a function of age. *Acustica*, 9, 303-308.
7. Kryter, K. D. (1970). *The effects of noise on man*. New York: Academic Press.
8. Kryter, K. D. (1983). Presbycusis, sociocusis, and nosocusis. *Journal of the Acoustical Society of America*, 73, 1897-1917.

Cross References

- | | | | |
|---|--|---|---|
| <p>2.302 Auditory sensitivity in quiet: effect of frequency;</p> <p>2.303 Auditory sensitivity in quiet: effect of age;</p> | <p>2.304 Auditory sensitivity in quiet: underwater listening;</p> <p>2.305 Auditory sensitivity in quiet and in noise: effect of binaural versus monaural listening;</p> <p>2.306 Factors affecting auditory</p> | <p>sensitivity in the presence of masking noise;</p> <p>2.307 Auditory sensitivity in noise: broadband noise masking;</p> <p>2.310 Auditory sensitivity in noise:</p> | <p>effect of bandwidth of multitone signals;</p> <p>10.311 Factors affecting the temporary threshold shift;</p> <p>10.315 Factors affecting noise-induced permanent threshold shift</p> |
|---|--|---|---|

2.302 Auditory Sensitivity in Quiet: Effect of Frequency

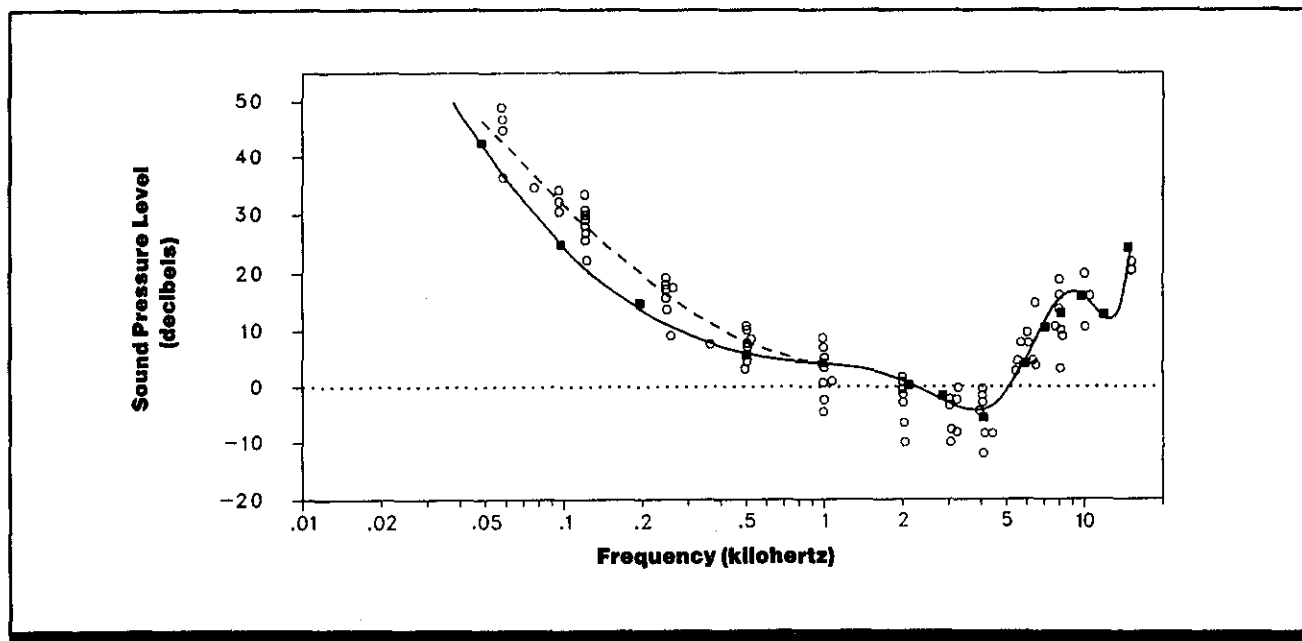

Figure 1. Threshold for pure tones or narrow-band stimuli in a free field (minimum audible field). Sound pressure level at threshold is plotted as a function of frequency. The solid curve is the ISO standard (Ref. 4) based largely on the data of Ref. 7 (filled squares). Open circles are data from 9 studies summarized in Ref. 2. Dashed curve is a second-order polynomial fit to the low-frequency data. (From Ref. 2)

Key Terms

Auditory detection; auditory sensitivity; frequency; minimum audible field; minimum audible pressure

General Description

The threshold for **pure tones** (or narrow-band noise) is a curvilinear function of frequency. Threshold is highest (sensitivity is lowest) at low frequencies (<1000 Hz); threshold decreases steadily up to ~4000 Hz and then rises again (Fig. 1). Measurements made under **free-field** listening conditions (minimum audible field, or MAF) produce lower thresholds for tones <6000 Hz and higher thresholds for tones >6000 Hz compared to values obtained when earphones are used (minimum audible pressure, or MAP) (Fig. 2). There are several reasons for this difference between free-field and earphone measurements: (1) free-field

listening is **binaural**, whereas earphone measurements are **monaural**, and binaural thresholds are lower (CRef. 2.305); with free-field listening, the acoustic properties of the head and body and the resonant properties of the outer ear lead to augmentation of the sound pressure level at the entrance to the ear canal (CRef. 2.802); and pressure on the ears from earphones induces a low-frequency masking noise from blood flow (Ref. 6).

For a given individual, substantial shifts in threshold may occur over a relatively narrow range of frequencies; such threshold patterns appear fairly stable over time (Fig. 3).

Applications

Hearing thresholds for individuals are used as a reference point in many situations (such as judging the effects of noise exposure).

Methods

Test Conditions

Figure 1 (Ref. 2)

- Pure tones or one-third octave band noise stimuli, with frequencies of 50-15,000 Hz

- Listening in free-field or diffuse field (values corrected to equivalent free-field thresholds); monaural or binaural presentation (to equate values for plotting, advantage of binaural over monaural thresholds taken as 3 dB)

Figure 2 (Ref. 8)

- Pure tone stimuli, with frequencies of 125-8000 Hz
- Presentation of tones through earphones
- Signal durations ranged from 0.8-1.2 sec; interval between signals ranged from 0.2-1.0 sec

Figure 3 (Ref. 3)

- Sinusoid signal presented monaurally through earphones, with frequencies of 1000-1800 Hz
- Signal duration was 250 msec with a linear rise/fall time of 25 msec and an interstimulus interval of 400 msec
- Twenty blocks of twelve trials

Experimental Procedure**Figure 1**

- Method of constant stimuli
- Independent variables: frequency of tone, tone loudness
- Dependent variables: dB SPL for just-audible tone, dB SPL for loudness inequality
- Subject's task: judge inequality of loudness in relation to pairs of pure tones, one of fixed intensity and the other variable in random

steps; adjust tone level to be just audible

- 290 subjects

Figure 2

- Method of loudness balancing
- Independent variables: tone loudness, earphone-coupler combination, tone frequency
- Dependent variable: dB SPL for judged loudness equality (balance)
- Subject's task: judge two sounds

to be equally loud

- 8-25 subjects

Figure 3

- Block-up-down two-interval forced-choice procedure
- Repeated measures design
- Independent variable: frequency of tone
- Dependent variable: dB SPL for just-audible tone
- Two threshold determinations per point

- Subject's task: adjust an attenuator so that tone was barely audible. Also, select frequencies, between 1000-2000 Hz, at which signal seemed either especially loud or soft. Thresholds were determined at these frequencies
- 5 subjects, normal hearing, paid volunteers selected on the basis of availability. They were not previously screened and had little previous listening experience

Experimental Results

- Thresholds for pure tones and narrow-band stimuli measured in a free field (MAF) are lowest at ~3000-4000 Hz.
- For frequencies <1000 Hz, threshold rises as frequency decreases; for frequencies >1000 Hz, threshold rises as frequency increases, but the rise is less regular than for low frequencies, due to diffraction caused by the subject's body.
- The solid curve in Fig. 1 is the standard curve of the International Organization for Standardization (ISO) (Ref. 4), which is based on the data of Ref. 5 (filled boxes).
- For low frequencies, a better fit to the data is provided by the dotted line representing the following second-order polynomial and set to meet the ISO curve at 1000 Hz (Ref. 2):

$$\text{SPL} = 17.18 (\log_{10} f)^2 - 144.65 (\log_{10} f) + 192.02,$$

where f is frequency in Hz.

- Thresholds measured with earphone presentation (MAP) are higher than thresholds measured in a free field (Fig. 2);

however, earphone thresholds vary with frequency in approximately the same way as free-field thresholds, with the greatest differences at high frequencies where diffraction by the body has an important effect.

- Solid line in Fig. 2 shows the ISO standard for earphone presentation (Ref. 5), based on data from Ref. 8.
- When thresholds are measured over a fairly small frequency interval, individual subjects show fairly large fluctuations in sensitivity to particular frequencies (Fig. 3). These shifts in threshold are stable, at least over a two-week period.

Variability

Standard deviations for the international standard MAF (free-field) curve in Fig. 1 range from 4.5-8.5 dB for frequencies of 50-8000 Hz (Ref. 4). Figure 2 shows error bars representing ± 1 standard deviation, which are averages from four studies summarized in Ref. 8.

Constraints

- Measurements are for pure tones (or narrow-band noise) only; results are likely to be different for the complex broadband sounds more typical of the natural environment.
- For earphone measurements, the precise threshold values obtained depend on the type of earphone used and the artificial ear used in calibrating the earphone.

- Many factors such as signal duration, age, and binaural versus monaural listening affect the hearing threshold and should be considered in applying these data under different conditions (CRef. 2.301).
- The most accurate and representative hearing thresholds for individuals are those based on multiple measurements separated in time.

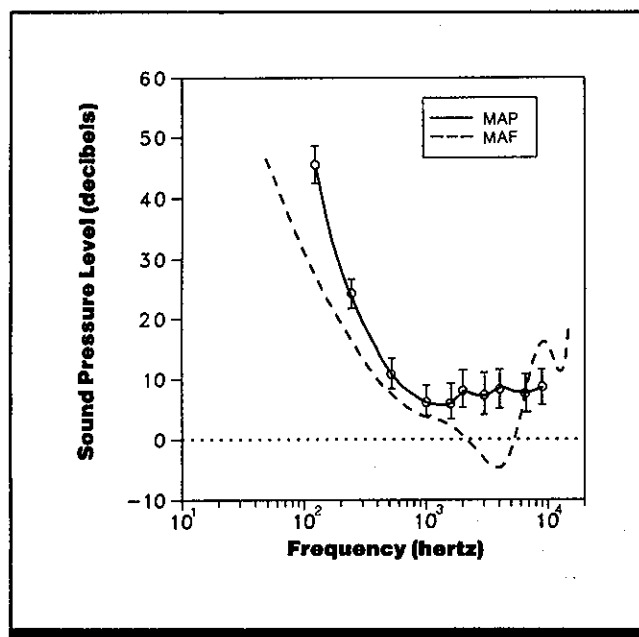

Figure 2. Thresholds for pure tones with earphone listening (minimum audible pressure). Sound pressure level at threshold is plotted as a function of frequency. The solid curve is from the ISO standard (Ref. 5) for the United States earphone-coupler combination (WE 705A earphone type and NBS 9-A coupler) as reported in Ref. 8. The dashed curve is the free-field threshold (MAF) curve from Fig. 1 (with modification for low frequencies). (From *Handbook of perception and human performance*)

Key References

1. Anderson, C. M. B., & Whittle, L. S. (1971). Physiological noise and the missing 6 dB. *Acustica*, 24, 261-272.

*2. Berger, E. H. (1981). Re-examination of the low-frequency (50-1000 Hz) normal threshold of hearing in free and diffuse sound fields. *Journal of the Acoustical Society of America*, 70, 1635-1645.

*3. Cohen, M. F. (1982). Detection threshold microstructure and its effect on temporal integration data. *Journal of the Acoustical Society of America*, 71, 405-409.

4. International Standards Organization. (1961). *Normal equal-loudness contours for pure tones and normal threshold of hearing under free field listening conditions*. (ISO-R-226). New York: ISO.

5. International Standards Organization. (1975). *Standard reference zero for the calibration of pure-tone audiometers (ISO-389)*. New York: ISO.

6. Killion, M. C. (1978). Revised estimate of minimum audible pressure: Where is the "missing 6 dB"? *Journal of the Acoustical Society of America*, 63, 1501-1508.

*7. Robinson, D. W., & Dadson, R. S. (1956). A redetermination of the equal-loudness relations for

pure tones. *British Journal of Applied Physics*, 7, 166-181.

*8. Weissler, P. G. (1968). International standard reference zero for audiometers. *Journal of the Acoustical Society of America*, 44, 264-275.

9. Whittle, L. S., Collins, S. J., & Robinson, D. W. (1972). The audibility of low-frequency sounds. *Journal of Sound and Vibration*, 21, 431-448.

Cross References

2.301 Factors affecting auditory sensitivity in quiet;

2.305 Auditory sensitivity in quiet and in noise: effect of binaural versus monaural listening;

2.802 Effects of the body on a sound field;

Handbook of perception and human performance, Ch. 14, Sect. 3.1

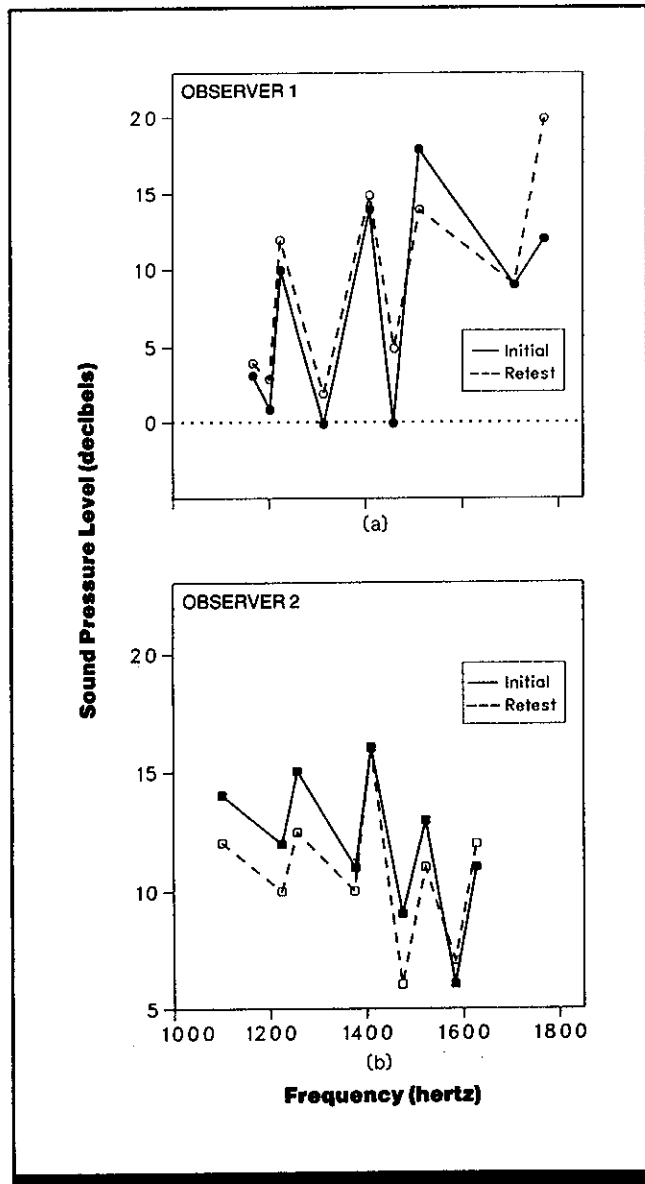

Figure 3. The fine structure of the threshold curve. Sound pressure level at threshold is plotted as a function of frequency for two subjects of Ref. 3. Solid lines are initial measurements and dotted lines are measurements taken two weeks later. (From *Handbook of perception and human performance*)

Notes

2.303 Auditory Sensitivity in Quiet: Effect of Age

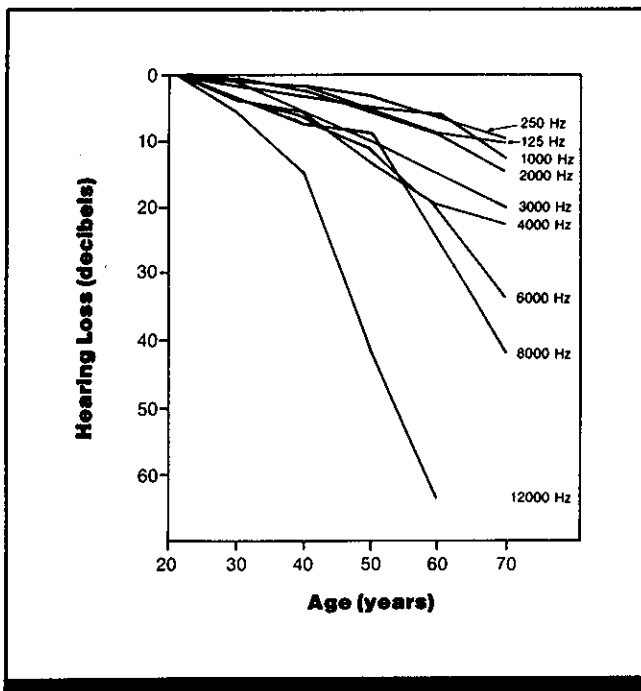

Figure 1. Hearing loss as a function of age and signal frequency. Hearing loss is given relative to the median threshold for the 18-24 age group. The median values shown in boldface in Table 1 are plotted. Data are for women and men or for women alone where women have significantly lower thresholds. (From Ref. 2)

Key Terms

Auditory detection; auditory sensitivity; presbycusis; sex differences; sociocusis

General Description

Hearing deteriorates from young adulthood to old age (although children have higher thresholds than young adults). The extent of the loss is greatest for high-frequency sounds. Age-related hearing loss (presbycusis) has been claimed to

be greater for men than for women, but recent studies attribute this difference to males' greater exposure to noise; this additional noise exposure causes a hearing loss (sociocusis) that is presumably added to the loss caused by age.

Methods

Test Conditions

- 125-12,000 Hz tones presented monaurally through Telephonics TDH-39 moving coil earphones

Experimental Procedure

- Method of limits
- Independent variables: signal frequency, signal intensity, age of subject, sex of subject

- Dependent variable: intensity of just-audible signal
- Subject's task: press a button when signal detected
- Male and female subjects selected from rural community in age

groups of 18-24, 25-34, 35-44, 45-54, 55-64, and 65-74, screened in each ear for clinically normal hearing; measurements made on a total of 326 male ears and 319 female ears

Experimental Results

- Hearing thresholds increase with age, declining most rapidly after 45-54 yr.
- The loss in hearing with age is greatest at frequencies >2000 Hz, and is especially striking at 12,000 Hz.
- Men have poorer hearing than women for frequencies >1000 Hz, and the sex difference increases with age; however, this difference is probably a consequence of males' greater exposure to industrial and/or military noise.

Repeatability/Comparison with Other Studies

The decline in hearing with age has been documented in many studies using a variety of experimental conditions and for large numbers of subjects. See, for example, Ref. 4, which surveys data from a number of studies which confirm the conclusions reported here. Reference 5 found that children have higher thresholds than adults, particularly for low frequencies.

Variability

Twenty-fifth and 75th percentiles are given in Table 1.

Table 1. Relative hearing threshold as a function of subject's age and stimulus frequency. (From Ref. 2)

Frequency (Hz)	Threshold (dB) re Youngest Age Group													
	Age 8-24 (176)		Age 25-34 (104)		Age 35-44 (93)		Age 45-54 (104)		Age 55-64 (74)		Age 65-74 (94)			
125	4.3		5.5		6.1		9.5		13.1		17.1			
	0.0		1.7		2.6		4.8		8.7		10.1			
	-3.9		-2.1		-1.1		1.8		4.6		6.0			
250	2.9		5.3		5.6		7.6		11.6		16.4			
	0.0		1.0		1.7		3.2		6.5		9.6			
	-3.4		-2.8		-1.5		0.1		2.3		4.5			
500	4.0		4.1		5.7		8.7		12.8		20.8			
	0.0		0.7		1.7		3.9		7.0		9.7			
	-2.7		-2.4		-2.0		0.4		2.4		4.8			
1000	3.7		4.1		6.4		9.5		10.0		24.7			
	0.0		1.0		1.7		4.7		5.6		12.8			
	-3.6		-2.4		-2.1		0.8		1.3		5.2			
2000	4.6		4.8		6.9		10.9		14.9 17.9		26.6 41.1			
	0.0		0.4		2.5		5.5		8.7 12.1		14.6 25.1			
	-4.2		-3.5		-0.5		1.2		4.6 5.7		9.4 15.6			
3000	4.6	8.0	6.9	11.1	10.3	16.5	18.2	29.4	20.2	45.3	40.6	53.1		
	0.0	2.1	1.5	5.8	5.5	8.6	9.9	18.2	14.8	31.5	19.8	40.9		
	-4.0	-0.9	-2.8	1.1	0.4	3.7	4.8	6.3	8.8	18.7	10.1	30.7		
4000	4.3	10.2	8.5	12.9	10.0	19.8	18.9	45.3	26.3	59.6	45.6	59.6		
	0.0	3.5	3.8	7.5	5.3	12.6	13.2	22.2	19.4	37.8	22.2	45.5		
	-4.3	-1.6	-0.2	2.4	1.7	5.4	6.6	12.4	8.7	30.7	12.1	29.9		
6000	5.8	9.6	8.8	12.9	13.6	20.9	22.4	36.7	28.7	59.7	47.2	66.5		
	0.0	2.5	3.6	5.3	6.2	12.4	11.2	23.1	22.3	49.5	33.9	50.9		
	-6.6	-2.6	0.5	-1.2	0.6	5.9	3.5	14.0	11.3	30.6	17.4	34.9		
8000	5.6		9.6		15.7		28.4	45.1	39.7	67.8	52.2	68.5		
	0.0		3.3		7.2		8.2	20.7	24.7	53.5	42.2	57.2		
	-6.3		-5.4		-2.3		2.6	10.7	11.0	30.1	32.2	48.7		
12000	9.2		17.6		28.5		58.0		70.0		70.0			
	0.0		5.2		14.4		41.7		64.2		70.0			
	-6.6		-4.0		3.9		19.0		54.2		63.1			

Note: The boldface value in each triplet is the median value; the bottom value is the 25th percentile and the top value is the 75th percentile. Thresholds are given relative to the threshold of the youngest age group at a given frequency. Accordingly, the median is always 0 dB in the first column. Where two sets of triplets appear together, the set on the left is for women and that on the right for men. In all these cases the men had significantly higher thresholds than the women. Where only one set is given, male and female thresholds did not differ significantly and were combined.

Constraints

- Measurements are for pure tones only; results are likely to be different for the complex sounds more typical of the natural environment.
- For earphone measurements, the precise threshold values obtained depend on the type of earphone used and the artificial ear used in calibrating the earphone.
- Many factors such as signal frequency, signal duration, and binaural versus monaural listening affect the hearing

- threshold and should be considered in applying these data under different conditions (CRef. 2.301).
- The most accurate and representative hearing thresholds for individuals are those based on multiple measurements separated in time.
 - Children are often difficult to test reliably and frequently are not checked for hidden middle ear infections (otitis media) before testing, which could affect low-frequency thresholds.

Key References

1. Corso, J. F. (1963). Age and sex differences in pure-tone thresholds. *Archives of Otolaryngology*, 77, 385-405.
 *2. Hinchcliffe, R. (1959). The

threshold of hearing as a function of age. *Acustica*, 9, 303-308.
 3. Johnson, D. L. (1978). *Derivation of presbycusis and noise induced permanent threshold shift to be used for the basis of a standard on the effects of hearing.* (Tech.

Rep. AMRL-TR-78-128). Wright-Patterson Air Force Base, OH: Aerospace Medical Research Laboratory.
 4. Kryter, K. D. (1983). Presbycusis, sociocucis and nosocucis. *Journal of Acoustical Society of America*, 73, 1897-1917.

5. Yoneshige, Y., & Elliott, L. L. (1981). Pure-tone sensitivity and ear canal pressure at threshold in children and young adults. *Journal of the Acoustical Society of America*, 70, 1272-1276.

Cross References

2.301 Factors affecting auditory sensitivity in quiet;

8.315 Noise masking of speech: effect of interaural phase relations for listeners of different ages;

10.315 Factors affecting noise-induced permanent threshold shift; *Handbook of perception and human performance*, Ch. 14, Sect. 3.1

2.304 Auditory Sensitivity in Quiet: Underwater Listening

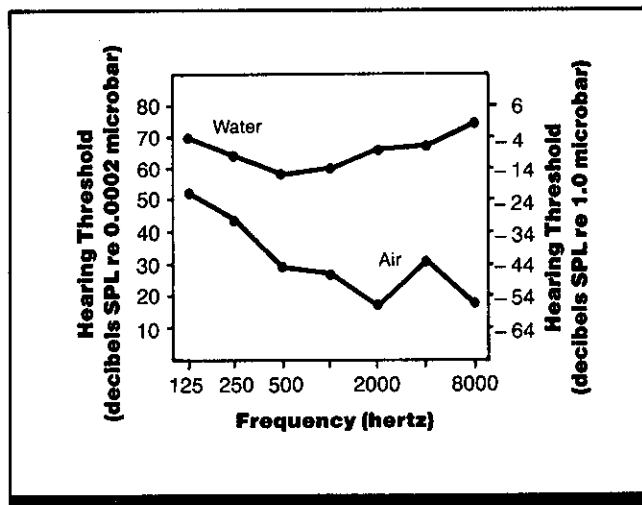

Figure 1. Hearing thresholds in air and underwater at 10.7-m depth as a function of stimulus frequency. (From Ref. 1)

Key Terms

Auditory detection; auditory sensitivity; underwater listening

General Description

Thresholds for pure tones heard underwater are generally higher than the corresponding thresholds for tones heard in air (Fig. 1). The difference increases as stimulus frequency

increases. Use of a diving hood further increases underwater thresholds even when there are channels through the hood to the ears. Underwater hearing appears to be mediated principally by bone conduction.

Methods

Test Conditions

- 500-msec sinusoidal stimuli of 125, 250, 500, 1000, 2000, 4000, and 8000 Hz; 50% duty cycle; 2.5-msec rise-fall time
- Underwater open-framework testing lab lowered to depth of 3.7-10.7 m (12-35 ft) in an elliptical fresh-water spring

61.0 x 121.9 m with maximum depth of 53.3 m; water temperature of 22°C; no currents; ambient noise comprised of waves, spring hiss, and fish sounds

- Air thresholds taken before underwater thresholds; for air testing, underwater stimulus and other background sounds picked up by hydrophone and led to earphones
- Diver wore open-circuit SCUBA

equipment and wet suit; diver seated in cage; position kept stable by weight-belt across legs; head in head positioner facing transducer

Experimental Procedure

- Békésy tracking procedure
- Independent variables: signal frequency, air versus water testing
- Dependent variable: hearing threshold, defined as sound pres-

sure level (SPL) of just audible signal

- Subject's task: adjust signal intensity until tone is just audible
- Diver held breath during threshold measurement to reduce noise level
- 8 subjects: 5 male and 3 female experienced divers with practice in taking hearing tests in air (ages 25-40)

Experimental Results

- Thresholds at 10.67-m underwater are relatively constant at ~70 dB SPL across a frequency range of 125-8000 Hz.
- Air thresholds change with stimulus frequency and average 20-30 dB SPL between 500 and 8000 Hz.
- Bone conduction appears to be the principal mechanism of underwater hearing, because connecting the ear canal to the outside of the diving hood (Ref. 3) or trapping air in the ear canal next to the tympanic membrane (eardrum) (Ref. 2) does not affect results.

Variability

Standard deviations are similar for underwater listening and listening in air; values range from 1.32-10.80 dB for underwater stimuli and 1.89-9.27 for stimuli in air.

Repeatability/Comparison with Other Studies

In a similar study (Ref. 3), underwater thresholds at a 9.14-m underwater depth were >90 dB for 4000 and 8000 Hz.

Constraints

- Thresholds were obtained only for brief pure tones; hearing may be better for more complex signals typical of the natural environment.
- Minimum audible field was measured for underwater thresholds, while minimum audible pressure was measured for thresholds in air. No correction was made for the typical ~6 dB difference in the two methods. Thus the difference between hearing underwater and hearing in air is even greater than shown in Fig. 1.
- Underwater thresholds were obtained while diver held breath; Ref. 1 estimates underwater breathing noise at ~30 dB. Underwater thresholds with normal breathing would thus be even worse in relation to air thresholds

than shown here. (For safety reasons, SCUBA divers should *not* hold breath underwater.)

- Underwater thresholds are 4-21 dB higher when a wet suit hood is worn than when no hood is worn (Ref. 3).
- Air thresholds used for comparison <1000 Hz are 10-15 dB greater than for a control study that eliminated all water and laboratory background noises.
- Many factors such as signal frequency, signal duration, age, and binaural versus monaural listening affect the hearing threshold and should be considered in applying these data under different conditions (CRef. 2.301).
- The most accurate and representative hearing thresholds for individuals are those based on multiple measurements separated in time.

Key References

*1. Brandt, J. F., & Hollien, H. (1967). Underwater hearing thresholds in man. *Journal of the Acoustical Society of America*, 42, 966-971.

2. Hollien, H., & Brandt, J. F. (1969). Effect of air bubbles in the external auditory meatus on underwater hearing thresholds. *Journal of the Acoustical Society of America*, 46, 384-387.

3. Hollien, H., & Feinstein, S. (1975). Contribution of the external auditory meatus to auditory sensitivity underwater. *Journal of the Acoustical Society of America*, 57, 1488-1492.

Cross References

2.301 Factors affecting auditory sensitivity in quiet

2.305 Auditory Sensitivity in Quiet and in Noise: Effect of Binaural Versus Monaural Listening

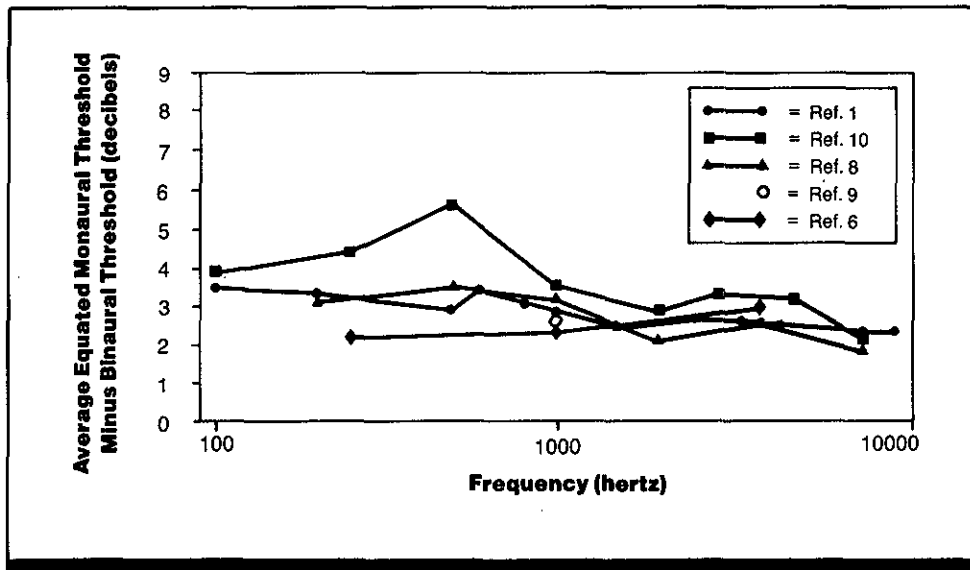

Figure 1. Difference between binaural and monaural thresholds for signals of different frequencies presented in quiet. Monaural signals were adjusted to equate sensation level in each ear. Results are shown for several studies summarized in Ref. 6.

Key Terms

Auditory detection; auditory masking; auditory sensitivity; binaural inhibition; binaural listening; binaural summation; binaural unmasking; masking level difference; monaural listening

General Description

Thresholds for **monaural** hearing in quiet are ~3 dB higher than **binaural** thresholds (i.e., binaural hearing is more sensitive); this difference is independent of signal frequency (Fig. 1). Subjects can detect 100% of stimuli presented binaurally at signal levels so low that no monaurally presented stimuli are detected (Fig. 2). Thus, a central processing mechanism is thought to summate stimuli presented simultaneously to both ears.

When a tone is presented in noise, binaural thresholds

are higher than monaural thresholds (binaural inhibition occurs) under "normal" listening conditions (tone and noise in phase in the two ears) or when both the tone and the noise are 180 deg out of phase (Fig. 3). In contrast, if the tone is in phase in the two ears while the noise is 180 deg out of phase, or vice versa, binaural summation occurs (i.e., binaural thresholds are lower than monaural thresholds). The effect of both summation and inhibition is greatest for tones of ~200-500 Hz and increases as the level of the noise increases (Refs. 5, 6).

Applications

Improvement of signal detection; masking of unwanted sounds.

Methods

Test Conditions

Figure 1 (Ref. 6)

- Monaural and binaural thresholds measured for pure tones and speech in quiet and masked by white noise, presented through headphones; pure tones presented

at frequencies from 100-10,000 Hz; monaural thresholds measured separately for each ear and binaural signals equated to be at same sensation level in each ear

Figure 2 (Ref. 3)

- Pure-tone stimuli of 200, 1000,

and 10,000 Hz (also 500 and 1300 Hz for some subjects) presented in quiet; binaural stimuli were adjusted to allow for differences in monaural thresholds between the two ears; subject in sound-proof booth

Figure 3 (Ref. 5)

- Pure tones from 100-5000 Hz masked by a 7000-Hz-wide white

noise; tones were either monaural or binaural, white noise always binaural; six combinations of phase relations between the ears (either in phase or 180 deg out of phase) for tones and noise; no adjustments made for different monaural thresholds for each ear

Experimental Procedure

Figure 1

- Method of adjustment, method of constant stimuli
- Repeated measures design, between-groups design
- Independent variables: monaural versus binaural presentation, frequency and intensity of tones, presence of masking noise
- Dependent variable: signal intensity at threshold (often defined as level at which probability of correct detection = 50%)
- Subject's task: indicate whether signal was present
- Subjects ranged in number from 3-84

Figure 2

- Method of constant stimuli

- Repeated measures design
- Independent variable: monaural versus binaural presentation
- Dependent variable: percentage of trials in which signal was heard
- Subject's task: indicate whether signal was present
- 2 subjects

Figure 3

- Method of adjustment
- Repeated measures design
- Independent variables: monaural versus binaural, phase relations of tones and noise
- Dependent variable: signal intensity at threshold, no threshold definition given
- Subject's task: adjust intensity of pure tone to threshold
- 3 subjects

Experimental Results

- Binaural thresholds in quiet are ~3 dB lower than the corresponding monaural thresholds (Fig. 1). The effect is roughly the same for signals of 100-10,000 Hz.
- For a given subject, the level at which a binaural signal can be detected on 100% of trials is still too low for a monaural signal to be detected on any trials (Fig. 2).
- This indicates that the advantage for binaural listening is not just statistical (i.e., due to **probability summation** [CRef. 1.814] or the fact that detection is statistically more probable with binaural listening if each ear is assumed to have an independent opportunity to detect the stimulus), but reflects summation of the signals from each ear at a central level by the auditory system.
- When tones are masked by noise, binaural thresholds may be lower than the corresponding monaural thresholds (due to binaural summation) or higher than monaural thresholds (due to binaural inhibition), depending upon the phase relations of the tones and the noise in the two ears.
- Binaural thresholds are higher than monaural thresholds (binaural hearing is less sensitive) when both the tone and the noise are either in phase or out of phase in the two ears.
- Binaural thresholds are lower than monaural thresholds (binaural hearing is more sensitive) when either the tone or the noise (but not both) is out of phase in the two ears. This improvement in detection with binaural listening is known as *binaural unmasking*, or the *masking level difference*.
- The amount of binaural unmasking generally increases as tone frequency decreases; however, results for frequencies <250 Hz are often contradictory.

Variability

The variability of the noise threshold was somewhat higher than the variability of the pure tone threshold (Ref. 9).

Repeatability/Comparison with Other Studies

Similar results for binaural versus monaural thresholds in quiet are reported across a variety of studies. Discrepant re-

Constraints

- Measurements are for pure tones only; results are likely to be different for the complex sounds more typical of the natural environment.
- Many different factors affect the hearing threshold in quiet, the threshold in noise, and binaural versus monaural

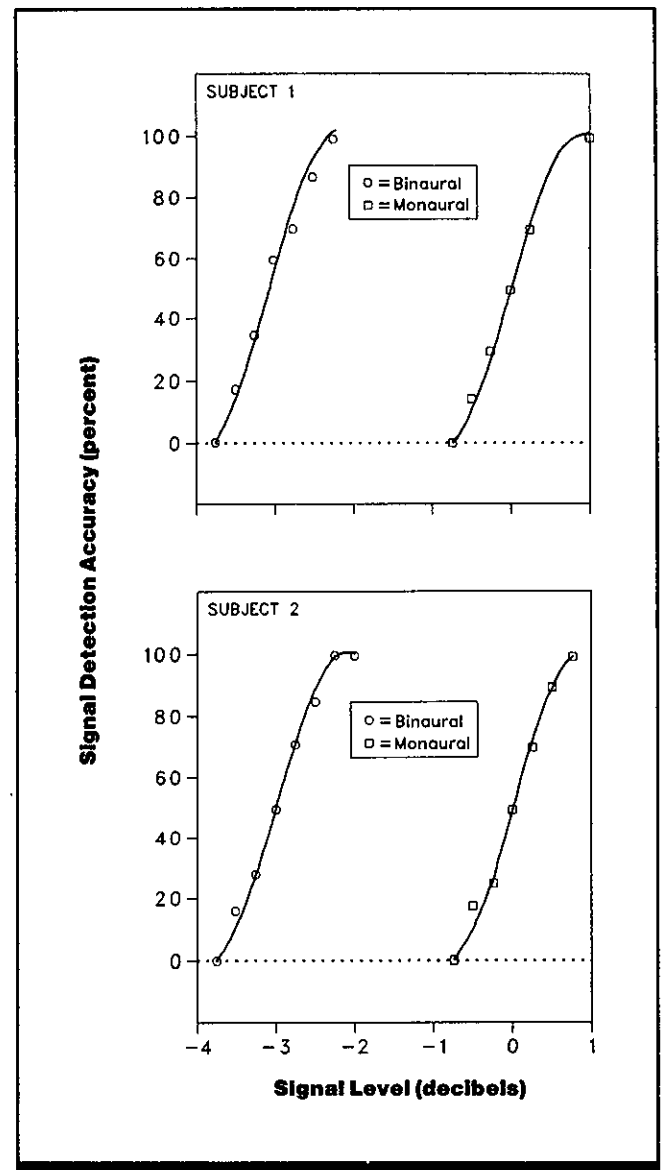

Figure 2. Comparison of binaural and monaural detection of a 1000-Hz tone presented in quiet. The graph for each subject plots the percentage of stimuli detected at each signal level (where 0 is the level at which detection accuracy reached 50% with monaural listening). Solid lines are ogives fitted to the data. (From *Handbook of perception and human performance*, based on Ref. 3)

sults in the literature may be due to failure to adjust binaural stimuli to equate the sensation level of the signals to each ear. The phenomenon of binaural unmasking has been widely replicated. Reference 8, for example, found that changing phase relations can change binaural thresholds by as much as 25 dB for a brief (10 msec) signal masked by a 7-Hz wide noise.

thresholds in noise and should be considered in applying these data under different conditions (CRefs. 2.301, 2.306, 2.314, 2.315, 8.315).

- The most accurate and representative hearing thresholds for individuals are those based on multiple measurements separated in time.

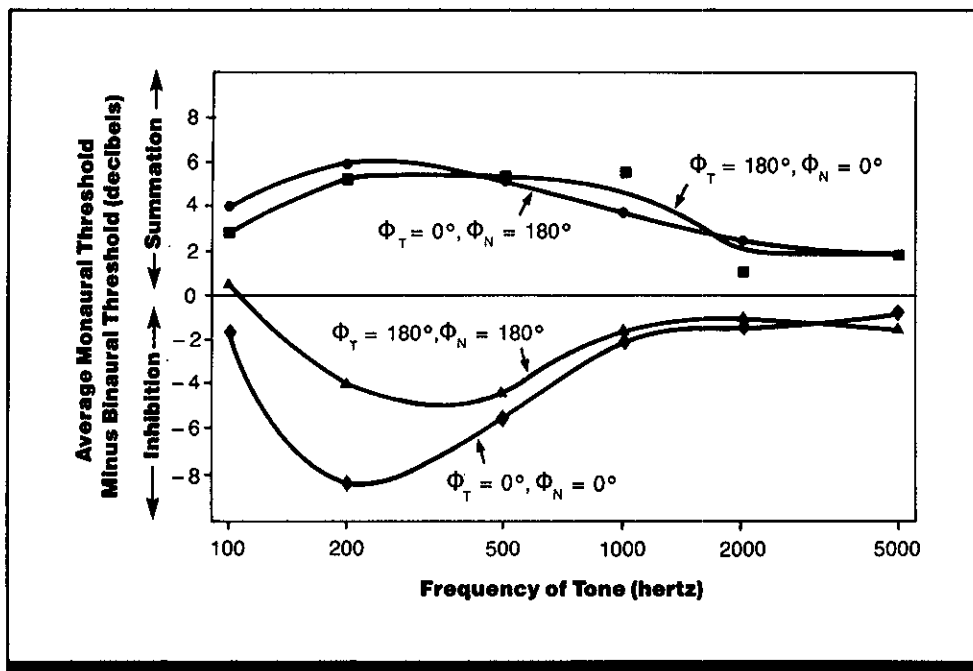

Figure 3. Difference between monaural and binaural thresholds for a pure tone masked by white noise. Graph shows the amount of binaural summation (binaural thresholds lower than monaural) or binaural inhibition (binaural thresholds lower than monaural) for tones of different frequencies. Interaural phase relations of the tone (ϕ_T) and the masking noise (ϕ_N) are indicated on the curves: tone and noise were either in phase (0 deg) or 180 deg out of phase. (From Ref. 5)

Key References

1. Caussé, R., & Chavasse, P. (1942). Différences entre le seuil de l'audition binaurculaire et le seuil monaurculaire en fonction de la fréquence. *Comptes Rendus des Séances de la Société de Biologie (Paris)*, 86, 301.

2. Caussé, R., & Chavasse, P. (1942). Différence entre l'écoute binaurculaire et monaurculaire pour la perception des intensités supraliminaires. *Comptes Rendus des Séances de la Société de Biologie (Paris)*, 86, 405.

*3. Chocholle, R. (1954). Etude statistique des seuils auditifs mon-

auraux et binauriaux. Interprétation des résultats. *Acustica*, 4, 341-350.

4. Green, D. M., & Henning, G. B. (1969). Audition. In D. H. Mussen & M. R. Rosenzweig (Eds.), *Annual Review of Psychology* (Vol. 20). Palo Alto, CA: Annual Reviews.

*5. Hirsh, I. J. (1948). The influence of interaural phase on interaural summation and inhibition. *Journal of the Acoustical Society of America*, 20, 536-544.

*6. Hirsh, I. J. (1948). Binaural summation—A century of investigation. *Psychological Bulletin*, 45, 193-206.

7. Hirsh, I. J. (1948). Binaural summation and interaural inhibition as a function of the level of masking noise. *American Journal of Psychology*, 61, 205-213.

8. Jeffress, L. A. (1965). Masking and binaural phenomena (Tech. Rep. No. DRL-A-245). Austin, TX: Defense Research Laboratory, Texas University. (DTIC No. AD616785)

9. Keys, J. W. (1947). Binaural versus monaural hearing. *Journal of Acoustical Society of America*, 19, 629-631.

10. Pollack, I. (1948). Monaural and binaural threshold sensitivity for tones and for white noise. *Journal of Acoustical Society of America*, 20, 52-58.

11. Shaw, W. A., Newman, E. B., & Hirsh, I. J. (1947). The difference between monaural and binaural thresholds. *Journal of Experimental Psychology*, 37, 229-242.

12. Wright, H. N. (1964). Backward masking for tones in narrow-band noise. *Journal of Acoustical Society of America*, 36, 2217-2221.

Cross References

1.814 Probability summation;

2.301 Factors affecting auditory sensitivity in quiet;

2.306 Factors affecting auditory sensitivity in the presence of masking noise;

2.314 Binaural reduction of masking: effect of signal frequency and listening conditions;

2.315 Binaural reduction of masking: effect of interaural phase differences;

8.314 Noise masking of speech: effect of interaural phase relations;

8.315 Noise masking of speech: effect of interaural phase relations for listeners of different ages

Notes

2.306 Factors Affecting Auditory Sensitivity in the Presence of Masking Noise

Key Terms

Auditory detection; auditory sensitivity; backward masking; broadband noise; forward masking; frequency; narrow-band noise; noise bandwidth; noise masking; signal detection; stimulus duration

General Description

The detectability of a signal is affected by the acoustic characteristics of sounds that occur close to the signal in time. Such sounds are said to *mask* the signal when they decrease its detectability. The amount of masking is measured as the difference between the threshold for the signal with and without the masking sound present. Masking can occur when the signal and mask are present at the same time (simultaneous masking) or when the mask precedes the signal (forward masking) or follows the signal (backward masking) by less than ~100-200 msec. Masking is greatest when the frequency of the mask is centered on the signal fre-

quency. For **pure-tone** signals, decreasing the frequency bandwidth of the mask within a **critical band** enhances signal detectability; increasing mask frequency beyond the critical band usually has no effect on detectability. Presenting signal and mask to different ears or to different perceived locations, as well as increasing signal duration, reduces the amount of masking. For pure tone masks, detectability may be enhanced if the signal and mask interact to produce audible beats or **combination tones**. The table lists the major factors that influence masking, describes their effects, and cites sources of further information.

Applications

Presentation of a signal in noisy environments. Characteristics of noise and signal determine whether detection is enhanced or inhibited. Simple manipulations of the signal and noise can enhance signal detection.

Constraints

- Most results are for pure-tone signals; results are likely to be different for complex signals more typical of the natural environment.

Factor	Effect	Reference
Simultaneous masking (mask present throughout presentation of signal)		
Signal delay	Delaying onset of signal until after onset of mask has no effect for narrow-band masks unless the mask is above the signal in frequency. Masking by broadband masks decreases as signal delay increases.	Ref. 18
Frequency of pure-tone masks	The closer the frequency of the mask to the frequency of the signal, the greater the masking effect. Masks of lower frequency than the signal decrease signal detectability more than masks of higher frequency. Masking is reduced when mask interacts with signal to produce combination tones.	Refs. 2, 3, 8, 14, 16; CRef. 2.309
Bandwidth and center frequency of narrow-band noise masks	A narrow-band noise mask centered on the signal frequency yields more masking than a pure tone because no combination tones are produced. Noise bands with center frequency below the signal frequency produce greater masking than bands centered above the signal frequency for mask level >40 dB sound pressure level.	Ref. 2; CRef. 2.308

Factor	Effect	Reference
Bandwidth of broadband noise masks	Masking increases as the bandwidth of the noise increases until the noise bandwidth exceeds a critical band; increasing the bandwidth beyond this value has no further effect. The more intense the mask within the critical band, the greater the masking effect.	Refs. 5, 9; CRef. 2.307
Number of signal components	For multitone complexes, masking by noise is constant regardless of the number of component tones as long as all added tones fall within a critical band; when components are added outside the critical band, the amount of masking increases as the number and frequency separation of the components increase.	CRef. 2.310
Signal duration	Detectability of a masked signal increases with signal duration up to ~200 msec; for durations below this limit, signal threshold may be maintained by compensating every tenfold decrease in signal duration with a tenfold increase in signal amplitude.	Refs. 1, 6, 7; CRef. 2.311
Mask intensity	The amount of masking increases as the intensity of the mask increases.	Refs. 9, 19
Interaural differences between signal and mask	Masking still occurs when the signal is presented to one ear and the mask to the other ear. Masking is reduced when the signal or the mask is out of phase in the two ears. Masking is reduced when the signal is presented to only one ear while the noise is presented to both.	CRefs. 2.314, 2.315, 8.314, 8.315
Backward masking (signal presented before mask onset)		
Signal-mask interval	Masking occurs only when mask follows signal interval by no more than 50-100 msec	CRef. 2.312
Frequency of pure-tone masks; bandwidth and center frequency of noise masks	Same effects occur as for simultaneous pure-tone masking, but with more variability.	Refs. 4, 12, 13; CRef. 2.312
Mask intensity	The amount of masking increases as the intensity of the mask increases.	Ref. 13
Forward masking (signal presented after mask offset)		
Mask-signal interval	The amount of masking decreases as the interval between mask offset and signal onset increases up to ~200 msec; for intervals greater than ~200 msec, no masking occurs; forward masking is less effective than simultaneous masking, even at small mask-signal intervals.	Ref. 4; CRef. 2.312
Frequency of pure-tone masks	Same general effects as in simultaneous masking; but masking decreases more rapidly as mask frequency departs from signal frequency than with simultaneous masking.	Refs. 4, 17; CRef. 2.312
Bandwidth and center frequency of noise masks	Same general effects as in simultaneous masking, but patterns of masking extend over a narrower frequency range.	Refs. 10, 13
Signal duration	Short-duration (5-msec) signals are masked more effectively by narrow-band noise, but longer ones (35 msec) are masked more effectively by tones.	Ref. 15
Mask intensity	The amount of masking increases as the intensity of the mask increases; however, the increase is always less rapid than with simultaneous masking. The shorter the delay between mask and signal, the more rapid the increase in masking as mask intensity increases.	Refs. 10, 17

Key References

1. Dallos, P. J., & Olsen, W. O. (1964). Integration of energy at threshold with gradual rise-fall tone pips. *Journal of the Acoustical Society of America*, 36, 743-751.
2. Egan, J. P., & Hake, H. W. (1950). On the masking pattern of a simple auditory stimulus. *Journal of the Acoustical Society of America*, 22, 622-630.
3. Ehmer, R. H. (1959). Masking patterns of tones. *Journal of the Acoustical Society of America*, 31, 1115-1120.
4. Fastl, H. (1976/77). Temporal masking effects: II. Critical band noise masker. *Acustica*, 36, 317-331.
5. Fletcher, H. (1940). Auditory patterns. *Reviews of Modern Physics*, 12, 47-65.
6. Garner, W. R., & Miller, G. P. (1947). The masked threshold of pure tones. *Journal of Experimental Psychology*, 37, 293-303.
7. Green, D. M., Birdsall, T. G., & Tanner, W. P., Jr. (1957). Signal detection as a function of signal intensity and duration. *Journal of the Acoustical Society of America*, 29, 523-531.
8. Greenwood, D. D. (1971). Aural combination tones and auditory masking. *Journal of the Acoustical Society of America*, 50, 502-543.
9. Hawkins, J. E., Jr., & Stevens, S. S. (1950). The masking of pure tones and speech by white noise. *Journal of the Acoustical Society of America*, 22, 6-15.
10. Jesteadt, W., Bacon, S. P., & Lehman, J. R. (1982). Forward masking as a function of frequency, masker level, and signal delay. *Journal of the Acoustical Society of America*, 33, 137-139.
11. Patterson, R. D., & Green, D. M. (1978). Auditory masking. In E. C. Carterette & M. P. Friedman (Eds.), *Handbook of perception, Vol IV* (pp. 337-360). New York: Academic Press.
12. Raab, D. H. (1961). Forward and backward masking between acoustic clicks. *Journal of the Acoustical Society of America*, 33, 137-139.
13. Robinson, C. E., & Pollack, I. (1971). Forward and backward masking: Testing a discrete perceptual-moment hypothesis in audition. *Journal of the Acoustical Society of America*, 50, 1512-1519.
14. Small, A. M., Jr. (1959). Pure-tone masking. *Journal of the Acoustical Society of America*, 31, 1619-1625.
15. Weber, D. L., & Moore, B. C. J. (1981). Forward masking by sinusoidal and noise maskers. *Journal of the Acoustical Society of America*, 69, 1402-1409.
16. Wegel, R. L., & Lane, C. E. (1924). The auditory masking of one pure tone by another and its probable relation to the dynamics of the inner ear. *Physiological Review*, 23, 266-285.
17. Widin, G. P., & Viemeister, N. F. (1979). Intensive and temporal effect in pure-tone masking. *Journal of the Acoustical Society of America*, 66, 388-395.
18. Zwicker, E. (1965). Temporal effects in simultaneous masking and loudness. *Journal of the Acoustical Society of America*, 38, 132-141.
19. Zwicker, E., & Scharf, B. (1965). A model of loudness summation. *Psychological Review*, 72, 3-26.

Cross References

- | | | | |
|---|---|---|--|
| <p>2.307 Auditory sensitivity in noise: broadband noise masking;</p> <p>2.308 Auditory sensitivity in noise: narrow-band noise masking;</p> | <p>2.309 Auditory sensitivity in noise: pure-tone masking;</p> <p>2.310 Auditory sensitivity in noise: effect of bandwidth of multitone signals;</p> <p>2.311 Auditory sensitivity in noise: effect of signal duration;</p> | <p>2.312 Auditory sensitivity in noise: nonsimultaneous masking;</p> <p>2.314 Binaural reduction of masking: effect of signal frequency and listening conditions;</p> | <p>2.315 Binaural reduction of masking: effect of interaural phase differences;</p> <p>8.314 Noise masking of speech: effect of interaural phase relations;</p> <p>8.315 Noise masking of speech: effect of interaural phase relations for listeners of different ages</p> |
|---|---|---|--|

Notes

2.307 Auditory Sensitivity in Noise: Broadband Noise Masking

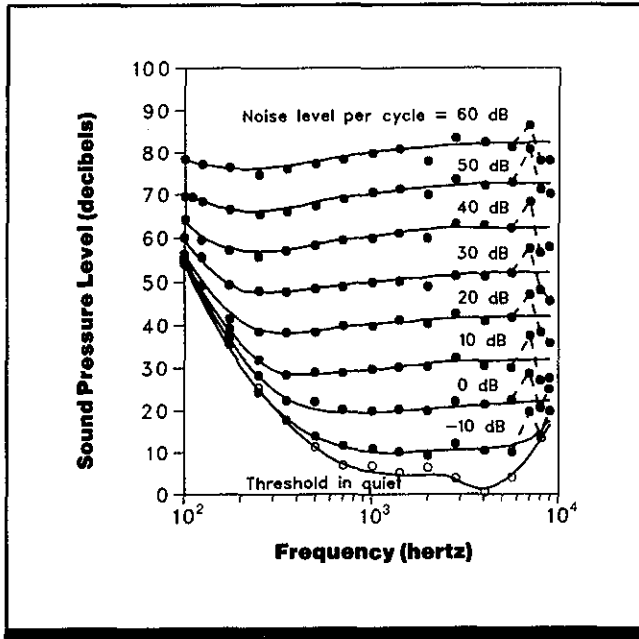

Figure 1. Masking of pure tones by broadband noise. Sound pressure level of the signal at threshold is shown as a function of signal frequency and spectrum level of the noise. Smooth curves were drawn through the data; deviations from the curve at the highest frequencies are due to the calibration problems with the earphones. (From Ref. 3)

Key Terms

Auditory detection; auditory sensitivity; broadband noise; critical band; signal detection; simultaneous masking

General Description

When a signal tone is presented simultaneously with broadband noise, the threshold for detecting the signal rises (signal detectability decreases) in proportion to the level of the noise (Fig. 1). For signals of frequencies >400 Hz, the threshold in noise increases very slowly as frequency increases.

It has been shown that, when a tone is masked by broadband noise, only a narrow portion of noise centered around the signal frequency actually is effective in masking a given

Applications

Improvement in signal detectability; masking of unwanted sounds. The investigation of masking patterns is one means used to assess the frequency selectivity of the auditory system. Noise is more useful than pure tones in masking

signal (Ref. 2). This narrow band of noise frequencies that is responsible for the masking is termed the *critical band*. Increasing the noise bandwidth beyond the critical band does not increase the amount of masking. The size of the critical band varies with center frequency, but for frequencies >1000 Hz, the critical band is generally equal to about 15-20% of the center frequency. (For a more detailed discussion of critical bands and methods of determining their size, see Ref. 6, Sect. 3.2.)

studies to determine the properties of internal auditory filters because fewer aural distortion products (beats and combination tones) are produced with noise masks than with pure tone masks.

Methods**Test Conditions**

- Signals were pure tones presented continuously at 16 frequencies between 100 and 9000 Hz; white noise mask with spectrum levels (sound pressure level per

cycle) of -10, 0, 10, 20, 30, 40, 50, and 60 dB (corresponding to sensation level of 20-90 dB)

- Signal and noise presented **monaurally** through PDR-10 earphone; opposite ear sealed and covered by dummy earphone; SPL measured in 6 cm² coupler

Experimental Procedure

- Independent variables: signal frequency, level of mask
- Dependent variables: threshold for tone in noise, defined as the sound pressure level at which the tone had a definite pitch

- Subject's task: adjust signal level until tone had a clear pitch
- Five to six threshold determinations per frequency in quiet, 2 to 5 determinations per frequency at each noise level
- 4 experienced subjects

Experimental Results

- Except near the threshold in quiet, raising the level of masking noise by 10 dB raises the signal threshold by 10 dB, although the changes are smaller and depend somewhat on frequency, for frequencies <1000 Hz (Fig. 1).

- Masked threshold increases slowly as frequency increases for frequencies >400 Hz (Fig. 1).

Variability

No information on variability was given.

Constraints

- Measurements are for pure-tone signals only; results are likely to be different for the complex sounds more typical of the natural environment.
- Many factors affect the detectability of a signal in the

presence of a masking sound and should be considered in applying these data under different conditions (CRef. 2.306).

- Critical-bandwidth measurements may break down at stimulus levels >80-90 dB or at long stimulus durations.

Key References

1. Fidell, S., Horonjeff, R., Teffteller, S., & Green, D. M. (1983). Effective masking bandwidths at low frequencies. *Journal of the Acoustical Society of America*, 73, 628-638.
2. Fletcher, H. (1940). Auditory patterns. *Review of Modern Physics*, 12, 47-65.
- *3. Hawkins, J. E. Jr., & Stevens, S. S. (1950). The masking of pure tones and speech by white noise.

Journal of the Acoustical Society of America, 22, 6-13.

4. Moore, B. C. J., & Glasberg, B. R. (1983). Growth of forward masking for sinusoidal and noise maskers as a function of signal delay; implications for suppression in noise. *Journal of the Acoustical Society of America*, 73, 1249-1259.
5. Scharf, B. (1970). Critical bands. In J. V. Tobias (Ed.),

Foundations of modern auditory theory (pp. 157-202). New York: Academic Press.

6. Scharf, B., & Buus, S. (1986). Audition I: Stimulus, Physiology, Thresholds. In K. R. Boff, L. Kaufman, & J. P. Thomas (Eds.), *Handbook of perception and human performance: Vol. 1. Sensory processes and perception*. New York: Wiley.
7. Zwicker, E. (1965). Temporal effects in simultaneous masking and loudness. *Journal of the*

Acoustical Society of America, 38, 132-141.

8. Zwicker, E., & Fastl, H. (1972). On the development of the critical band. *Journal of the Acoustical Society of America*, 52, 699-701.
9. Zwicker, E., & Terhardt, E., (1980). Analytical expressions for critical-band rate and critical bandwidth as a function of frequency. *Journal of the Acoustical Society of America*, 68, 1523-1525.

Cross References

- 2.306 Factors affecting auditory sensitivity in the presence of masking noise;

- 2.308 Auditory sensitivity in noise: narrow-band noise masking;
- 2.309 Auditory sensitivity in noise: pure-tone masking

2.308 Auditory Sensitivity in Noise: Narrow-Band Noise Masking

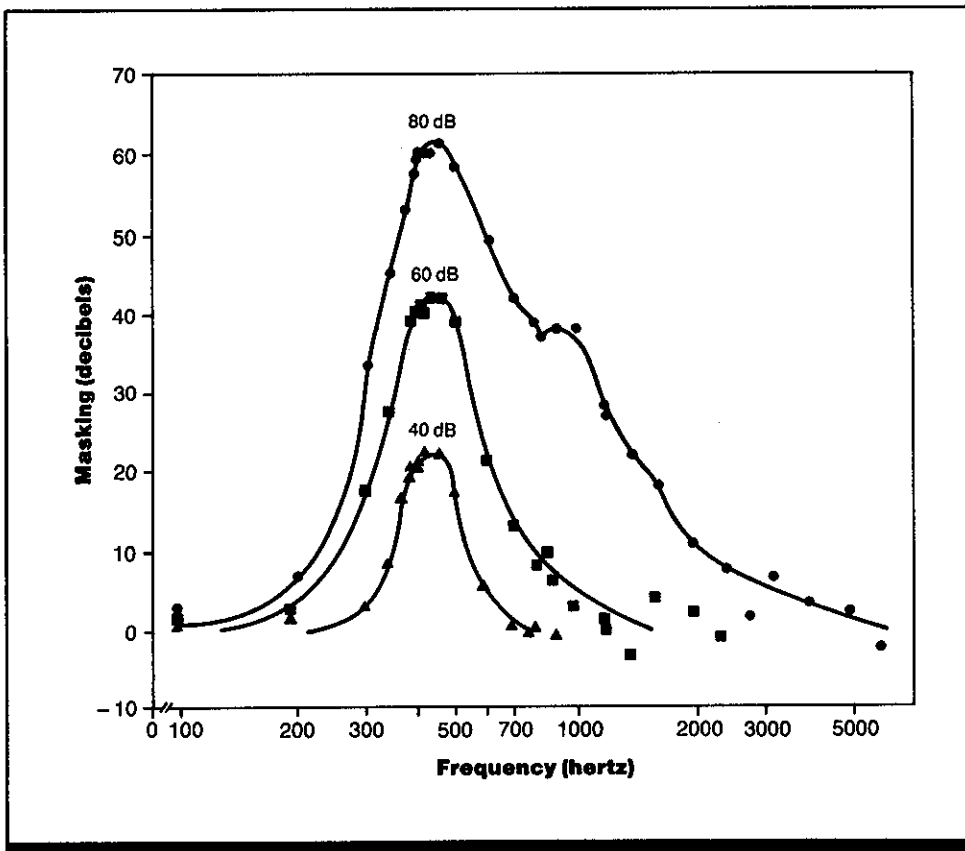

Figure 1. Masking of pure tones by narrow-band noise (90 Hz wide, centered at 410 Hz), as a function of signal frequency and overall sound pressure level of the noise. Data are shown for one subject. (From Ref. 1)

Key Terms

Auditory detection; auditory sensitivity; narrow-band noise; noise masking; signal detection; simultaneous masking

General Description

A narrow-band noise presented simultaneously with a **pure tone** signal may mask the signal (i.e., decrease signal detectability). Masking is greatest for tones that fall within the frequency range of the noise and declines with increasing frequency separation of tone and noise. At high mask in-

tensities, narrow-band noise is more effective in masking tones with frequencies above the noise band than with frequencies below the noise. Narrow-band noise masks produce smoother masking functions than do pure-tone masks because there is less interaction between mask and signal tone.

Applications

Improvement of signal detectability; masking of unwanted sounds.

The investigation of masking patterns is one means used to assess the frequency selectivity of the auditory system.

Narrow-band noise is more useful than pure tones in masking studies to determine the properties of internal auditory filters because fewer aural distortion products (**beats** and **combination tones**) result from narrow-band noise masks than from pure tone masks.

Methods

Test Conditions

- Signals were pure tones of 100-6000 Hz; tone duration 700 msec
- Mask was 90-Hz wide narrow-

band noise with center frequency of 410 Hz and uniform spectrum level; overall sound pressure level (SPL) of 20-80 dB

- **Monaural** testing with opposite ear covered; PDR-10 earphone and 6 cm³ coupler

Experimental Procedure

- Method of adjustment using threshold bracketing procedure
- Independent variables: mask intensity, signal frequency
- Dependent variable: amount of masking, defined as the increase in

signal intensity necessary to render it detectable in the presence of the mask

- Subject's task: adjust signal intensity until "anything" was detected
- 5 subjects with normal hearing

Experimental Results

- The detectability of pure tones decreases in the presence of narrow-band masking noise of similar frequency. The decline is greatest for tones that fall within the frequency range of the noise.
- The amount of masking declines as the difference between the signal frequency and the frequency limits of the noise increases. For low mask intensities, this decline is symmetrical; that is, masking is equal for frequencies an equal distance above and below the mask frequency. For high mask intensities, the masking effect is asymmetrical; frequencies above the noise band are masked more than those below the noise (a phenomenon referred to as the upward spread of masking).
- As the intensity of the noise mask increases, the range of frequencies that are masked increases.
- Narrow-band noise centered on 410 Hz is a more effective mask than a 400-Hz pure tone for signal frequencies below ~ 1200 Hz, but the pure-tone mask produces greater masking for frequencies above 1200 Hz (CRef. 2.309).
- Pure-tone masks interact with the signal to produce beats and combination-tones which reduce masking in local frequency regions (CRef. 2.309). Such effects are minimal with narrow-band masks and occur only at high mask intensities (e.g., discontinuity in the masking curve for 80 dB mask in Fig. 1 represents frequency region where masking is decreased because of audible combination tone).
- Masking functions for narrow-band noise masks are smoother than those for pure-tone masks because there is less interaction between mask and signal tone. Pure-tone masks are somewhat better than narrow-band noise masks at masking signals of much higher frequency than the mask (Fig. 2).

Variability

Results are shown for only 1 subject; results for other subjects were very similar. For individual subjects, variability of threshold measurements was lowest for signals falling

Constraints

- Measurements are for pure tone signals only; results are likely to be different for the complex sounds more typical of the natural environment.
- For earphone measurements, the precise threshold values

Key References

*1. Egan, J. P., & Hake, H. W. (1950). On the masking pattern of a simple auditory stimulus. *Journal of the Acoustical Society of America*, 22, 622-630.

2. Patterson, R. D., & Green, D. M. (1978). Auditory masking. In E. C. Carterette & M. P. Friedman (Eds.), *Handbook of Perception, Vol. IV: Hearing*

(pp. 337-360). New York: Academic Press.

3. Zwicker, E., & Scharf, B. (1965). A model of loudness summation. *Psychological Review*, 72, 3-26.

Cross References

2.306 Factors affecting auditory sensitivity in the presence of masking noise;

2.307 Auditory sensitivity in noise: broadband noise masking;

2.309 Auditory sensitivity in noise: pure-tone masking;

Handbook of perception and human performance, Ch. 14, Sect. 3.2

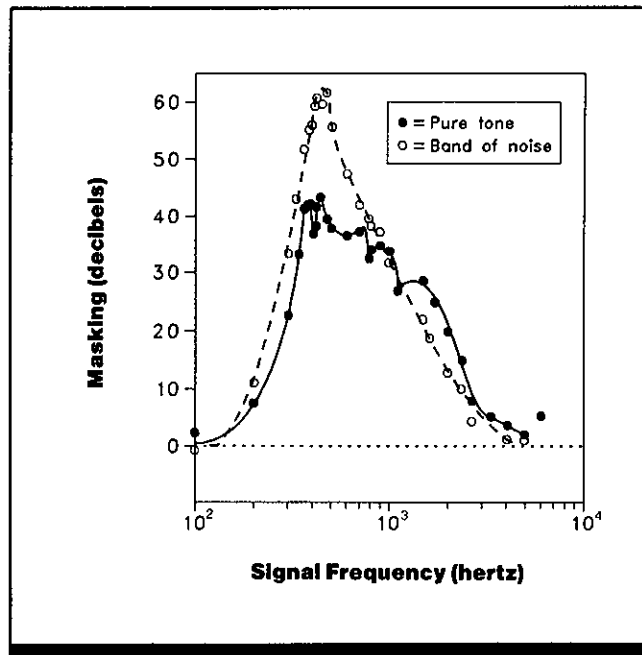

Figure 2. Masking of pure tones by pure tone or narrow-band noise as a function of signal frequency. Amount of masking (difference between masked and unmasked threshold intensity of the signal) is shown for an 80 dB SPL pure tone (400 Hz) or narrow-band noise (365-455 Hz) mask. (From Ref. 1)

within the frequency limits of the noise (standard deviation = ~ 1.3 dB) and greater for higher and lower frequencies (standard deviation = ~ 2.9 - 3.6 dB).

Repeatability/Comparison with Other Studies

This result has been obtained consistently in a variety of studies employing different techniques. The results are also consistent with results obtained from physiological experiments and experiments in loudness summation.

obtained depend on the type of earphone used and the artificial ear used in calibrating the earphone.

- Many factors affect the detectability of a masked signal and should be considered in applying these data under different conditions (CRef. 2.306).

2.309 Auditory Sensitivity in Noise: Pure-Tone Masking

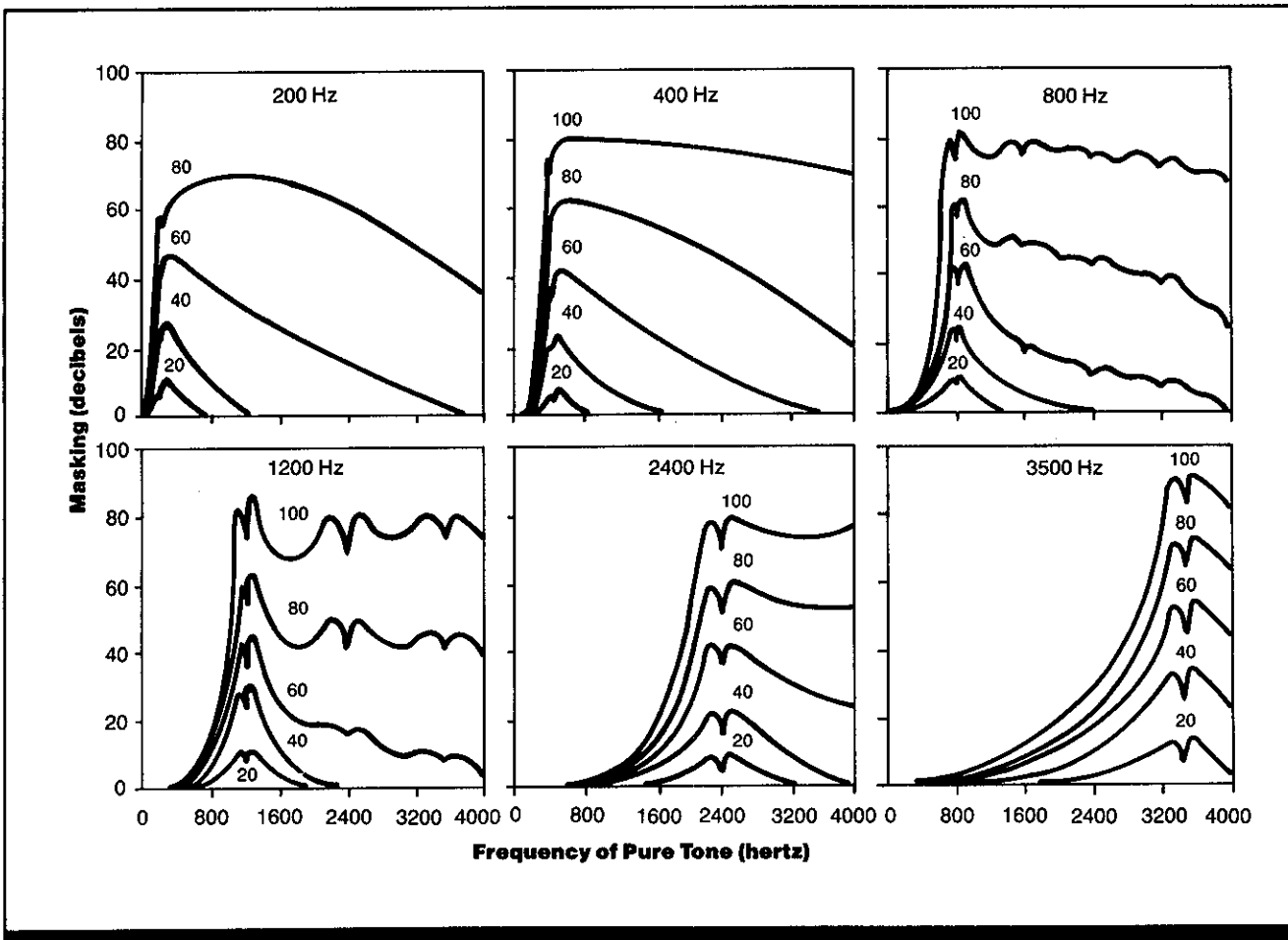

Figure 1. Masking of pure tones by pure tones as a function of signal frequency (Study 1). Amount of masking (difference between masked and unmasked threshold intensity of the signal) is shown for tonal masks 20-100 dB above threshold. (From Ref. 1)

Key Terms

Auditory detection; auditory sensitivity; noise masking; pure tone masking; signal detection; simultaneous masking

General Description

The detectability of a **pure tone** (the signal) may be decreased when a second pure tone (the **mask**) is presented simultaneously. The masking effect of a pure tone is greatest for signal frequencies near the mask frequency, but some masking also occurs for signals that have higher or lower frequencies. As with masking by narrow-band noise (CRef. 2.308), masking by pure tones tends to spread more to higher frequencies than to lower frequencies, especially at mask levels >40 dB sound pressure level (SPL) (Fig. 1). When the mask is a pure tone, the signal and mask may interact to produce beats or **combination tones** that decrease the effectiveness of the mask, producing dips or discontinuities in the masking curves (i.e., regions of lower threshold) (Fig. 1).

A tone may be masked by two tones with frequencies above and below the signal frequency. When both masking tones fall within a narrow frequency range (**critical band**) around the signal, the amount of masking is a function of the frequency separation of the two masking tones and does not depend upon their center frequency. When frequency separation of the tones is greater than a critical band, masking does depend on center frequency and the masking effect is much less (Fig. 2).

When a multiplied-noise signal (e.g., the result of multiplying a 1000-Hz tone by noise at 5-40 Hz) is masked by two pure tones, the pattern of masking is very similar to that obtained when only the low-frequency masking tone is used (Fig. 3).

Applications

Improvement of signal detectability; masking of unwanted sounds.

The investigation of masking patterns is one means used to assess the frequency selectivity of the auditory system. Pure tones are less useful than narrow-band noise in masking studies to determine the properties of internal auditory filters because more aural distortion products (beats and combination tones) are produced with pure tone masks than with narrow-band noise masks.

Methods

Test Conditions

Study 1 (Fig. 1, Ref. 1)

- Signals were pure tones of up to 4000 Hz
- Masks were pure tones of 200-3500 Hz
- Mask was 20-100 dB above threshold
- No signal or mask duration information was given

Study 2 (Fig. 2, Ref. 4)

- Masks were two different sinusoids presented at 77 dB SPL
- Signal center frequencies were 250, 1000, 4000 Hz
- Signal frequency was always midway between the two masks
- Signal intensity varied in five steps from ~30-75 dB
- Signal duration was 124 msec
- 12 dB background SPL present through experimental trial
- Stimuli presented monaurally via headphones
- Presentation intervals cued by onset lights
- Detection threshold defined as 75% correct response level
- 200 observations for each signal condition

Study 3 (Fig. 3, Ref. 6)

- Four signals used, all centered at 1000 Hz: 44 Hz-wide-multiplied noise, 80 Hz-wide-multiplied noise, 80 Hz-wide-frequency modulated signal and 1000 Hz pure tone
- Mask SPL was 37, 57, 77, or 97 dB
- All mask and signal durations were 250 msec with 25 msec rise and fall times
- Stimuli presented monaurally via TDH-39 earphone
- In single 4AFC (four-alternative forced-choice) trial four identical masks presented in four sequential intervals; masking conditions randomly assigned
- Threshold computed as average SPL of 12 reversals

Experimental Procedure

Study 1

- Independent variables: signal frequency, masking frequency, mask intensity level
- Dependent variable: amount of masking, defined as ratio of minimum audible SPL of signal with mask to that without mask
- No subject task information given
- No subject information given

Study 2

- Two-alternative forced-choice
- Within-subjects design
- Independent variables: signal frequency, masking frequency, frequency separation for two-tone masks, ear mask or to which ear signal was presented
- Dependent variable: signal SPL at 75% correct detection response level
- Subjects indicated which of two presentation intervals contained the signal
- Subjects were three students well practiced on the task and paid hourly for participation

Study 3

- Four-alternative forced-choice, method of limits
- Within-subjects design
- Independent variables: signal type, interval of two-tone mask, frequency of single-tone mask, mask SPL
- Dependent variables: average signal SPL after 12 reversals for method of limits, average signal SPL after six reversals for 4AFC method
- Subject's task was to choose which of four stimulus presentation intervals sounded different from the other three
- 5 subjects with normal hearing followed by further experimentation with 1 subject with normal hearing

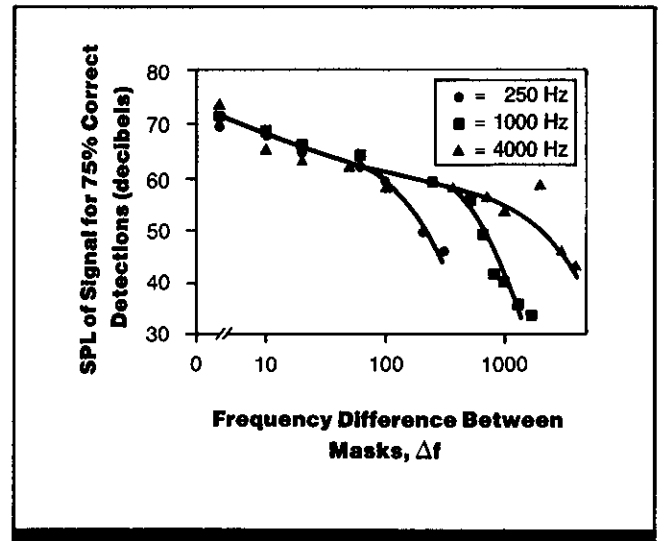

Figure 2. Two-tone masking of pure tones as a function of frequency separation between masking tones (Study 2). Masks were 77 dB SPL, centered on signal frequencies of 250, 1000, or 4000 Hz. Data are shown for one subject. (From Ref. 4)

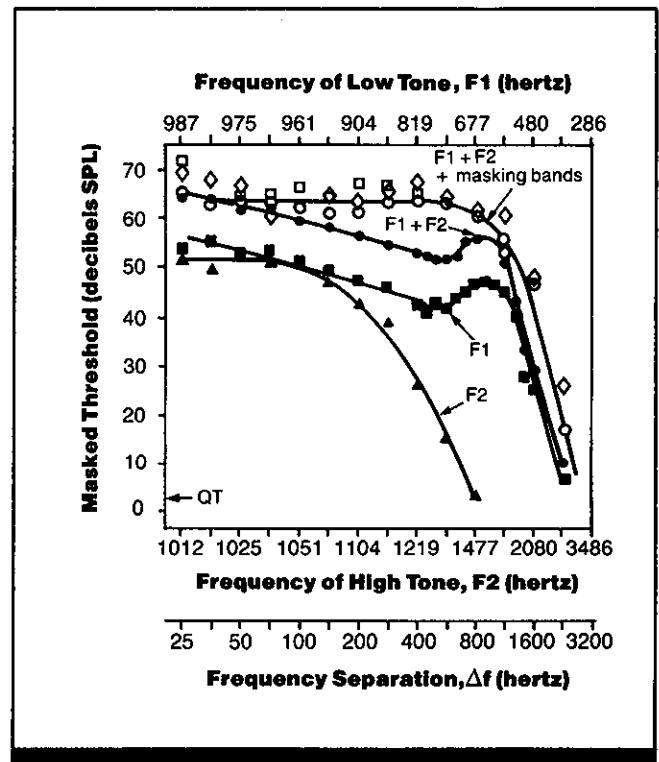

Figure 3. Masking of 80-Hz multiplied noise by single and two-tone masks and tone + noise mask (Study 3). Masks were: a low tone (F1) or a high tone (F2) of the frequency shown on the abscissa; a two-tone mask (F1 + F2) of the indicated frequency separation; two-tone mask with narrow noise bands added to mask combination tones arising from the interaction of tonal mask and signal. Point QT on ordinate is the threshold for the signal in quiet. (From Ref. 6)

Experimental Results

- Except for signal frequencies within the region of the masking tone (and signals near the **overtones** of the mask for high-intensity masks), masking of a tone signal by a pure tone mask decreases as the frequency of the signal departs from the frequency of the mask (Fig. 1).
- When signal and masking tone are within ~ 20 Hz of one another, signal and mask interact to produce beats which render the signal more detectable and cause a dip in the masking curve. For higher mask intensities, beating also occurs at harmonic frequencies of the mask (Fig. 1).
- For mask levels below ~ 40 -50 dB, masking curves are symmetrical; i.e., masking is equal for signals above and below the mask frequency. As mask intensity increases, however, masking spreads upward, i.e., high frequencies are masked more than low frequencies and the curves become asymmetrical (Fig. 1).
- For a central tone masked by two flanking pure tones, when the frequency separation of the two tones is within a narrow frequency range (critical band), masking is inde-

pendent of the center frequency of the masking tones and depends only on their frequency separation. However, at frequency separations equal to or greater than the critical band, the masking effect diminishes and is dependent on center frequency (Fig. 2).

- For a two-tone mask at frequency separations of less than a critical band, threshold decreases ~ 10 dB per decade increase in frequency separation, but there are large dips or notches in the function. Masking with only the lower-frequency tone yields a very similar function. The discontinuities in the tonal masking functions can be eliminated by adding to the two-tone mask narrow bands of noise at the frequencies of the combination tones produced by the interaction of the signal and the low-frequency tone of the two-tone mask (Fig. 3).

Variability

Figure 3 shows data for one subject; results for two other subjects were similar. No other variability information was given.

Constraints

- Measurements are for pure-tone or narrow-band signals only; results are likely to be different for the complex sounds more typical of the natural environment.
- Many factors affect hearing threshold in the presence of a masking stimulus and should be considered in applying these data under different conditions (CRef. 2.306).

Key References

1. Deatherage, B. H. (1972). Auditory and other sensory forms of information presentation. In H. P. Van Cott & R. G. Kinkade (Eds.), *Human engineering guide to equipment design* (pp. 123-160). New York: McGraw-Hill.
2. Egan, J. P., & Hake, H. W. (1950). On the masking pattern of a simple auditory stimulus. *Journal*

of the Acoustical Society of America, 22, 622-630.

3. Ehmer, R. H. (1959). Masking pattern of tones. *Journal of the Acoustical Society of America*, 31, 1115-1120.

*4. Green, D. M. (1965). Masking with two tones. *Journal of the Acoustical Society of America*, 37, 802-813.

5. Greenwood, D. D. (1971). Aural combination tones and auditory masking. *Journal of the Acoustical Society of America*, 50, 502-543.

*6. Nelson, D. A. (1979). Two-tone masking and auditory critical bandwidths. *Audiology*, 18, 279-306.

7. Small, A. M., Jr. (1959). Pure-tone masking. *Journal of the Acous-*

tical Society of America, 31, 1619-1625.

*8. Wegel, R. L., & Lane, C. E. (1924). The auditory masking of one pure tone by another and its probable relation to the dynamics of the inner ear. *Physiological Review*, 23, 266-285.

9. Zwicker, E. (1980). Reversed behaviour of masking at low levels. *Audiology*, 19, 330-334.

Cross References

- 2.306 Factors affecting auditory sensitivity in the presence of masking noise;

2.308 Auditory sensitivity in noise: narrow-band noise masking; *Handbook of perception and human performance*, Ch. 14, Sect. 3.2

Notes

2.310 Auditory Sensitivity in Noise: Effect of Bandwidth of Multitone Signals

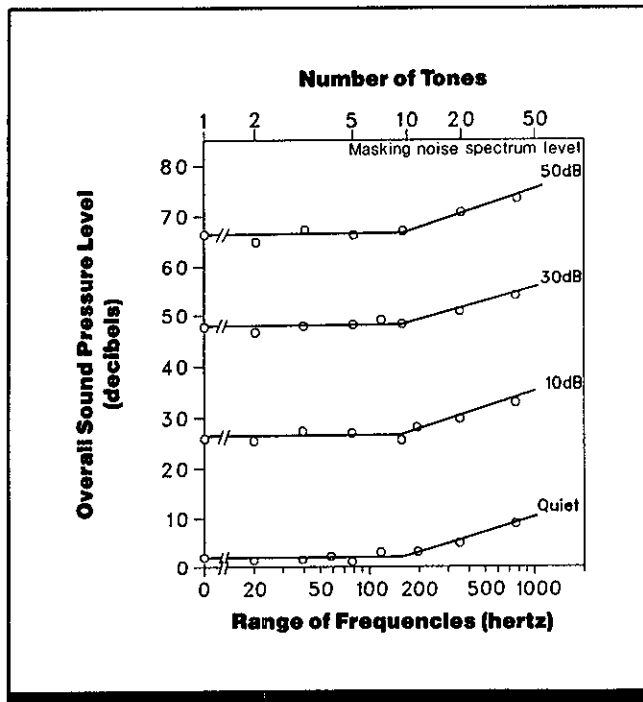

Figure 1. Overall sound pressure level at threshold for a multitone complex at four levels of masking noise and in quiet as a function of number of component tones and frequency spacing between highest and lowest tones of the complex. The zero on the abscissa indicates presentation of a single 1100-Hz tone. (From Ref. 2)

Key Terms

Auditory detection; auditory sensitivity; bandwidth; broad-band noise; multitone complex; noise masking; signal detection; simultaneous masking

General Description

The total stimulus energy required to detect a multitone complex presented in noise or in quiet remains constant regardless of the number of tones in the complex, provided all tones fall within a narrow frequency range (**critical band**); that is, as tones are added to the complex, the level of each tone can be decreased so that overall stimulus level is constant and the complex will remain equally detectable pro-

vided all the tones are within the critical band. When the frequency separation of the components is greater than the critical band, the total energy of the complex must be increased as the number of tones increases for the complex to remain audible. Increasing the level of masking noise increases the overall sound pressure level required to detect the multitone complex, but does not change the effects of adding tonal components within or outside of the critical band.

Applications

Improvement of signal detectability; masking of unwanted sounds.

Methods**Test Conditions**

- Signals were multitone complexes composed of 1-40 pure tones; one tone was 1100 Hz and tones were added at lower frequencies evenly spaced 10-20 Hz apart;

all tones of equal intensity; tones had random phase relations; frequency separation of tones co-varied with number of tones in complex

- Signal presented **monaurally** in quiet or with **white-noise** mask that decreased 3 dB per octave above

1000 Hz; **noise spectral level** of 10-50 dB

Experimental Procedure

- Békésy tracking procedure
- Independent variables: presence or absence of mask, number of

tones presented, frequency separation of tones

- Dependent variable: sound pressure level of complex at threshold
- Subject's task: adjust level of complex until just audible
- One or two measurements per point
- 1 subject

Experimental Results

- Overall sound pressure level (SPL) required for detection of a multitone complex remains constant regardless of the number of component tones or the frequency spacing between the highest and lowest tones, provided all tones fall within a narrow frequency range or critical band (flat portion of the curves in Fig. 1).
- Threshold for the multitone complex increases linearly with the number and frequency separation of the components when components are added outside the critical band (portion of curves with nonzero slope).

- Threshold increases as the level of masking noise increases. However, noise level does not affect the shape of the functions relating SPL at threshold to number and spacing of tonal components, nor does masking noise level change the size of the critical band (i.e., the frequency separation at which overall SPL at threshold ceases to remain constant as components are added to the complex and bandwidth increases).

Variability

No information on variability available.

Constraints

- The width of the critical band may change at very high mask intensities (>80-90 dB SPL) or at very low intensities near threshold, as well as for very brief stimulus durations (<100 msec) (Ref. 2). There are also individual differences in the width of the critical band.

- Measurements are for pure tones only; results are likely to be different for the complex sounds more typical of the natural environment.
- Many factors affect the detectability of a signal in the presence of a masking sound and should be considered in applying these data under different conditions (CRef. 2.306).

Key References

1. Gässter, G. (1954). Über die Hörschwelle für Schallereignisse mit verschieden breitem Frequenzspektrum. *Acustica*, 4, 408-414.

*2. Scharf, B. (1970). Critical bands. In J. V. Tobias (Ed.), *Foundations of modern auditory theory* (pp. 157-202). New York: Academic Press.

Cross References

2.306 Factors affecting auditory sensitivity in the presence of masking noise;

Handbook of perception and human performance, Ch. 14, Sect. 3.1

2.311 Auditory Sensitivity in Noise: Effect of Signal Duration

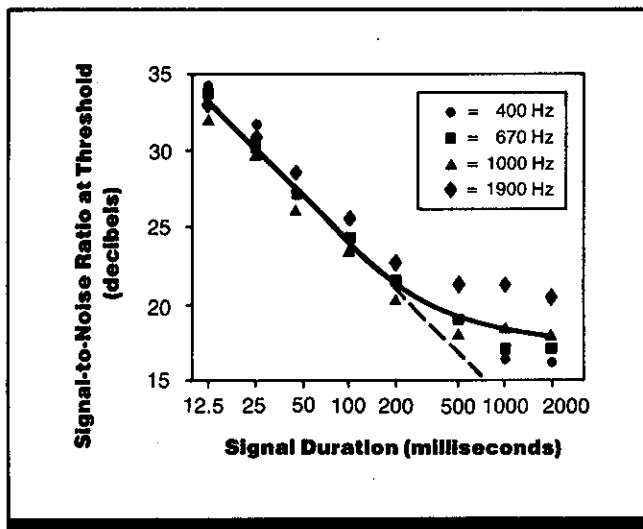

Figure 1. Masked threshold for pure tone signals of various frequencies in white noise as a function of signal duration. Solid line is a visual fit to the data and the dashed portion indicates linear integration of acoustic energy. (From Ref. 2)

Key Terms

Auditory detection; auditory masking; auditory sensitivity; broadband noise; noise masking; signal detection; simultaneous masking; stimulus duration; temporal summation

General Description

Detectability of a tone in noise is affected by the duration of the signal as well as by the signal-to-noise ratio (the relative power of the signal). For signal durations below ~200 msec, sensitivity decreases linearly as duration de-

creases (i.e., the signal-to-noise ratio necessary to maintain signal audibility increases as duration decreases). Increasing signal duration beyond 200 msec has only a small effect on signal detectability.

Applications

Improvement of signal detectability; masking of unwanted sounds. Under conditions where it may be impractical or impossible to alter the actual signal-to-noise ratio, signal detectability may be improved by increasing signal duration.

Methods

Test Conditions

- Signals were 400-, 670-, 1000-, or 1900-Hz pure tones presented for 12.5, 25, 50, 100, 200, 500, 1000, or 2000 msec; mask was white noise low-pass-filtered at 7000 Hz; noise presented at over-

- all levels of 20, 30, 50, 70, 90 or 110 dB sound pressure level (SPL) (figure plots data for four highest noise levels)
- Tones presented at approximately 4-sec intervals
- Stimuli presented **binaurally** via earphones in a sound deadened room; PDR-8 earphones calibrated in 6 cm³ coupler

Experimental Procedure

- Method of limits, ascending staircase procedure
- Independent variables: signal frequency, signal duration, signal-to-noise ratio
- Dependent variable: signal-to-

- noise ratio of tone at threshold, defined as the value at which subject heard signal twice in succession
- Subject's task: indicate whether signal was heard on each trial
- Ten threshold determinations per condition
- 4 subjects

Experimental Results

- For signal durations below ~200 msec, the auditory system integrates acoustic energy linearly over time: signal-to-noise ratio at threshold increases by ~10 dB for every tenfold increase in stimulus duration up to ~200 msec. For durations <200 msec, the curve is given by the equation $S/N + 10 \log t = 44.2$, where S/N is the signal-to-noise ratio expressed in decibels and t is signal duration in milliseconds.
- For durations of 200-1000 msec, threshold decreases

only very slowly; increasing signal duration beyond ~1000 msec brings no further improvement in signal detectability.

Variability

Between-subject differences in threshold for short-duration tones (15-600 msec) can be as large as ~20 dB SPL (Ref. 1).

Repeatability/Comparison with Other Studies

References 1 and 3 obtained similar results.

Constraints

- Measurements are for pure tones and white noise masks only; results may be different for complex signals more typical of the natural environment or for other types of masking sounds.
- For earphone measurements, the precise threshold values

obtained depend on the type of earphone used and the artificial ear used in calibrating the earphone.

- Many factors affect the detectability of a signal in the presence of a masking sound and should be considered in applying these data under different conditions (CRef. 2.306).

Key References

1. Dallos, P. J., & Olsen, W. O. (1964). Integration of energy at threshold with gradual rise-fall tone pips. *Journal of the Acoustical Society of America*, 36, 743-751.

*2. Garner, W. R., & Miller, G. P. (1947). The masked threshold of pure tones. *Journal of Experimental Psychology*, 37, 293-303.

3. Green, D. M., Birdsall, T. G., & Tanner, W. P., Jr. (1957). Signal detection as a function of signal intensity and duration. *Journal of the Acoustical Society of America*, 29, 523-531.

Cross References

2.306 Factors affecting auditory sensitivity in the presence of masking noise

2.312 Auditory Sensitivity in Noise: Nonsimultaneous Masking

Key Terms

Auditory sensitivity; backward masking; forward masking; narrow-band noise; noise masking; signal detection; temporal summation

General Description

The detectability of a signal that occurs in close temporal proximity to another sound (or mask) depends on the temporal relations among signal onset and offset, and mask onset and offset. In backward masking, the mask follows the signal. The detectability of the signal increases (sound pressure level required to detect the signal increases) as the interval between signal onset and mask onset increases for intervals up to 50-100 msec. When mask onset follows signal onset by >100 msec, masking no longer occurs.

In forward masking, the mask precedes the signal. The detectability of the signal increases as the interval between the offset of the mask and the onset of the signal increases up to 100-200 msec. At longer delays, no masking occurs. Even at brief mask-signal intervals, forward masking does not reduce signal detectability as much as backward masking or simultaneous masking (signal and mask present at the same time).

Applications

Improvement of signal detectability; masking of unwanted sounds

Methods

Test Conditions

Study 1 (Ref. 1)

- Tone burst signals with frequencies of 6500, 8500, and 1100 Hz; duration of 1 msec and 500 msec
- Mask was filtered white noise; center frequency of 8500 Hz with 1800 Hz bandwidth; duration of 500 msec; SPL was 70 dB
- Forward masking duration (from end of mask to end of signal) ranged from 2-200 msec
- Backward masking durations ranged from (-20) - 0 msec from the end of the signal
- Signal and mask had 0.5 msec

Gaussian-shaped rise and fall durations

- Stimuli presented monaurally via Beyer DT 48 S earphones

Study 2 (Ref. 7)

- Signal was pure 1000 Hz tone
- Mask was narrow band noise at 80 dB SPL of 600 msec duration; mask center frequency varied from 500-800 cps in 100 cps intervals, 800-1200 cps in 50 cps intervals, 1200-1500 cps in 100 cps intervals and at 1750, 2000, 2500, and 3500 cps
- Mask SPL was always 80 dB
- Signal and mask onset differences were 500, 100, 30, 25, 20,

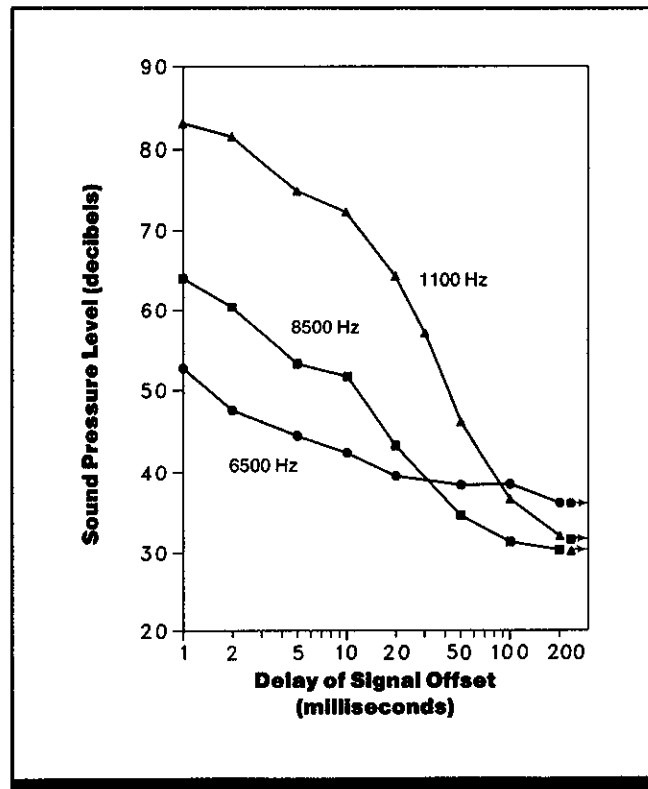

Figure 1. Forward masking of pure tones by narrow-band noise (Study 1). SPL of the signal at threshold is shown as a function of delay of signal offset (interval between mask offset and signal offset); interval between mask offset and signal onset = value on x-axis minus 1 msec. Arrows indicate thresholds in quiet. (From Ref. 1)

- 15, 10, and 0 msec; 0 msec onset difference represents simultaneous masking
- Tone and noise were alternated with noise alone in three-sec intervals
- Signal always terminated 100 msec before mask terminated
- Tones presented monaurally
- Apparatus information not given

Experimental Procedure

- Modified Békésy-tracking method

- Within-subjects design
- Independent variables: signal-mask onset difference, signal-mask frequency relation, signal and mask duration
- Dependent variable: signal intensity at threshold; no threshold definition given
- Subject's task: indicate the presence or absence of the signal in noise on each trial
- 9 subjects (Study 1); 3 subjects (Study 2); no other subject information given

Experimental Results

- The threshold for a tone pulse masked by narrow-band noise presented prior to the tone (forward masking) decreases monotonically with an increase in the delay between the offset of the mask and the onset of the signal tone up to delays of 100-200 msec. At signal delays >200 msec, no masking occurs (Fig. 1).
- Forward masking is initially greater for signals whose frequency falls within the limits of the noise band than for signals of higher or lower frequency than the masking noise. Frequencies above the noise band are masked more

than frequencies below the noise at short signal delays (Fig. 1).

- As signal delay increases, signal detectability increases more rapidly for signals with higher initial masked thresholds. Thus, by the time signal delay reaches 200 msec, all three types of signal (those with frequencies higher than, lower than, or within the noise band) are equally detectable (Fig. 1).
- Reference 2 has proposed the following formula for calculating the effect of forward masking:

$$M = a(b - \log \Delta t)(L_0 - c),$$

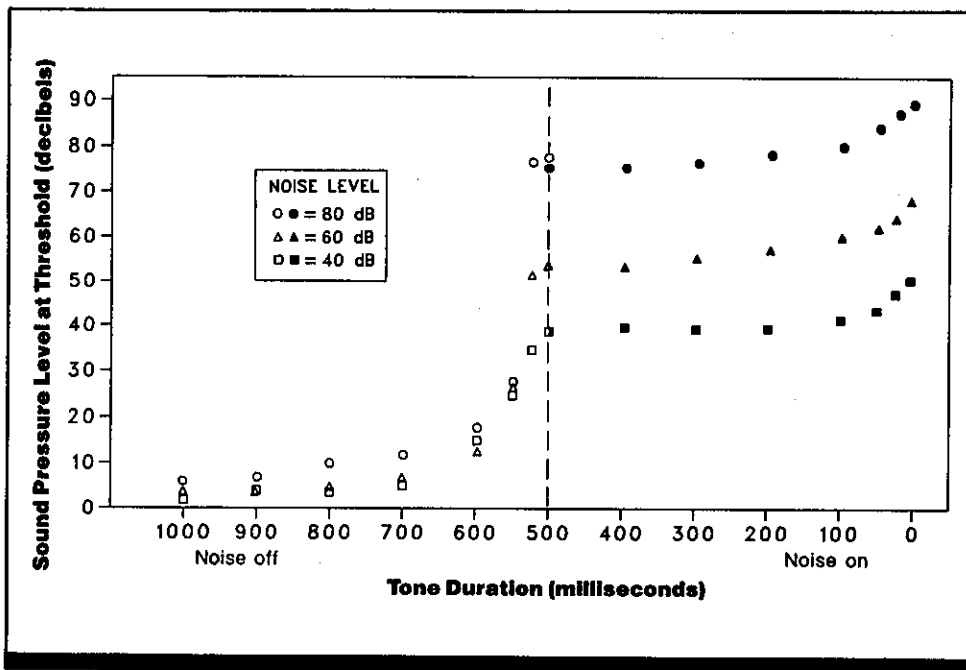

Figure 2. Backward masking of a pure tone by narrow-band noise (Study 2). Sound pressure level of the signal at threshold is plotted as a function of tone duration for three levels of masking noise. Mask onset was always 500 msec before offset of tone; i.e., interval between signal and mask onset equals tone duration minus 500 msec. (From Ref. 7)

where M = amount of masking in decibels, Δt = signal delay in milliseconds, L_0 = threshold, and a , b , and c are parameters selected to yield the best fit to data from individual listeners. Once values of a , b , and c have been determined, the formula can be used to predict masking (M) for different mask levels or signal durations.

- The threshold for a tone burst is increased when narrow-band noise follows the onset of the tone (backward masking) by no more than ~ 200 msec. As the interval between tone onset and noise onset decreases from 200-0 msec, the amount of backward masking produced by the noise increases substantially (Fig. 2).
- For these short tone-mask intervals, in addition to exerting a backward-masking effect, the noise also effectively decreases the duration of the tone, limiting the amount of temporal summation that can occur (CRef. 2.311) and thus decreasing the detectability of the tone. When the amount of

threshold increase due to masking alone is calculated by adjusting for the threshold shift due to interference with temporal summation, backward masking is found to be most effective over the 30-msec interval immediately prior to the mask's onset. Masking is decaying rapidly by 50 msec before the mask onset, and the mask has almost no effect on signal detectability when it follows signal onset by 100 msec or more.

Variability

Backward-masking effects are more variable than simultaneous and forward-masking effects. Within-subject variability across trials in masked thresholds can be as high as 10 dB, in contrast to typical differences of ~ 2 dB (Ref. 1).

Repeatability/Comparison with Other Studies

Results presented here are consistent with those in a number of other studies.

Constraints

- Measurements are for pure-tone signals and narrow-band noise masks only; results may be different for the complex sounds more typical of the natural environment.
- For earphone measurements, the precise threshold values obtained depend on the type of earphone used and the artificial ear used in calibrating the earphone.

Key References

- *1. Fastl, H. (1976/77). Temporal masking effects: I. Critical band noise masker. *Acustica*, 36, 317-331.
2. Jesteadt, W., Bacon, S. P., & Lehman, J. R. (1982). Forward masking as a function of frequency, masker level, and signal delay.

Journal of the Acoustical Society of America, 71, 950-962.

3. Raab, D. H. (1961). Forward and backward masking between acoustic clicks. *Journal of the Acoustical Society of America*, 33, 137-139.
4. Robinson, C. E., & Pollack, I. (1971). Forward and backward

masking: Testing a discrete perceptual-moment hypothesis in audition. *Journal of the Acoustical Society of America*, 50, 1512-1519.

5. Weber, D. L., & Moore, B. C. J. (1981). Forward masking by sinusoidal and noise maskers. *Journal of the Acoustical Society of America* 69, 1402-1409.

6. Widin, G. P., & Viemeister, N. F. (1979). Intensive and temporal effects of pure-tone forward masking. *Journal of the Acoustical Society of America*, 66, 388-395.

- *7. Wright, H. N. (1964). Temporal summation and backward masking. *Journal of the Acoustical Society of America*, 36, 927-932.

Cross References

2.306 Factors affecting auditory sensitivity in the presence of masking noise;

2.311 Auditory sensitivity in noise: effect of signal duration;

Handbook of perception and human performance, Ch. 14, Sect. 3.2

2.313 Auditory Sensitivity in Noise: Interaural Masking

Key Terms

Forward masking; interaural masking; masking; signal detection; simultaneous masking

General Description

Masking is the reduction in audibility of a signal due to the presence of another sound (the mask) that occurs simultaneously with the signal or near it in time. Interaural masking occurs when the signal and mask are presented to different ears, and thus effectively interact at a central level of the auditory system. Interaural masking is more frequency-dependent than **monaural** masking; it occurs only within a narrow frequency range (**critical band**) and, unlike monaural masking, shows roughly equal effects for signal frequencies both above and below the mask frequency. Interaural masking by a tone mask may raise the threshold for a test tone by as much as ~15 dB for test tones with frequencies within a half critical band of the masking tone frequency. Interaural masking declines rapidly when the onset of the signal tone is delayed relative to the onset of the mask.

Applications

Improvement of signal detectability; masking of unwanted sounds.

Methods

Test Conditions

- Tone and mask presented to different ears through Audiovox 9-C receivers secured in ear canals by highly damped 2 cm³ couplers and soft semi-insert tips
- Mask: 250-msec 1000-Hz tone burst repeated once per second; sensation level of 5-70 dB
- Test signals: 10-msec tone burst; frequency range 400-3000 Hz
- Tone and mask either delivered simultaneously or with tone onset

delayed by different intervals relative to onset of mask

Experimental Procedure

- Békésy tracking procedure
- Independent variables: onset asynchrony of tone and mask, frequency of test tone, sensation level of mask
- Dependent variable: shift in threshold for tone with, versus without, mask
- Subject's task: press button (to decrease intensity) if tone heard, release button (to increase intensity) if tone not heard
- 2 subjects

Experimental Results

- A masking tone presented to one ear decreases the detectability of a test tone presented to the other ear only when the frequency of the test tone is close to the frequency of the masking tone (i.e., within the same critical band) (Fig. 1).
- Interaural masking effects are roughly symmetrical for signal frequencies above and below the mask frequency (Fig. 1).
- Interaural masking is greatest when signal and mask are presented simultaneously. Masking decreases as the onset of the signal tone is delayed relative to the onset of the mask; the difference between masked and unmasked thresholds is ~11 dB when mask and signal are onset simultaneously but only ~3-4 dB when signal onset is delayed by 160 msec.

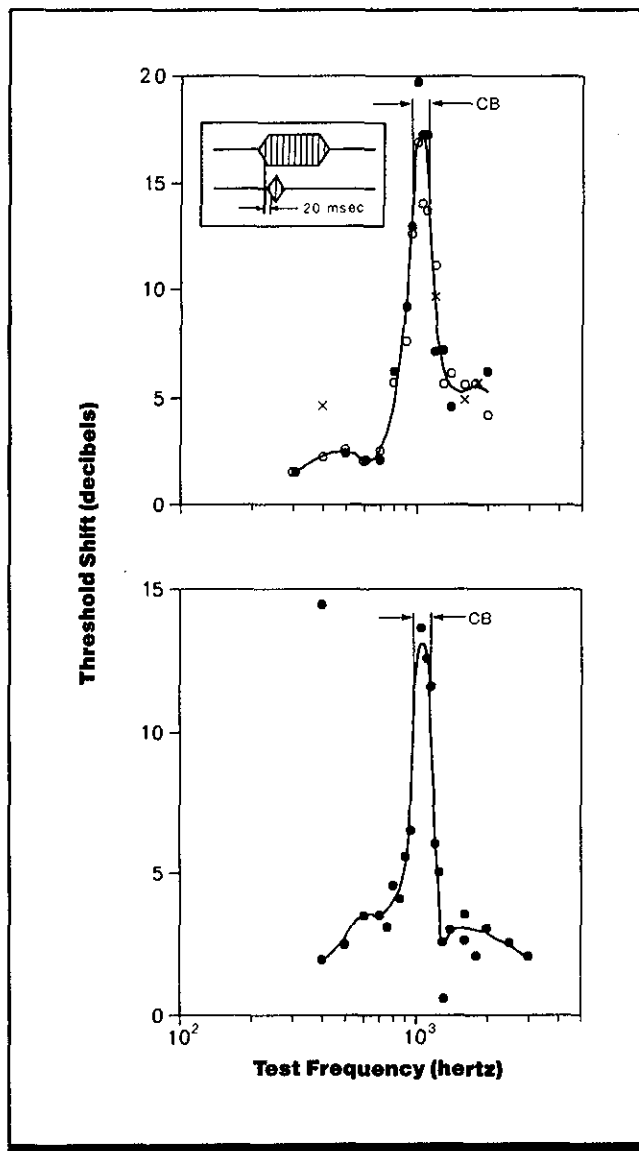

Figure 1. Interaural masking of tones. Mask was a 1000-Hz tone at 60 dB sensation level whose onset preceded tone signal onset by 20 msec (inset shows temporal relations of mask [top shaded area] and tone signal [bottom]). Threshold shift for tone signal (difference between masked and unmasked thresholds) is given as a function of the frequency of the tone signal. Data are shown for 2 subjects. Curves were fit to the data by eye. CB indicates width of the critical band. (From Ref. 4)

- Interaural masking is greatest when signal and mask are presented simultaneously and decreases as the onset of the signal tone is delayed.
- Interaural masking increases as mask sensation level increases for simultaneous onsets of mask and test tone.
- Comparison with results of a related experiment shows that a pulsed mask produces more interaural masking than does a steady-state (continuous) mask.

Variability

No information on variability was given. In a similar pilot experiment, standard errors from some results appeared to range from ~1.5-3 dB.

Repeatability/Comparison with Other Studies

Other studies have found very little interaural masking when signal onset is delayed relative to mask onset except at high mask levels that could have allowed bone conduction (Ref. 1).

Constraints

- Measurements are for pure tone signals and masks only; results are likely to be different for the complex sounds more typical of the natural environment.
- True interaural masking can be measured only when precautions are taken to prevent the masking sound from reaching the test ear via bone conduction.

Key References

1. Elliot, L. L. (1962). Backward masking: Monotic and dichotic conditions. *Journal of the Acoustical Society of America*, 34, 1108-1115.

2. Zwillocki, J. J. (1953). Acoustic attenuation between the ears. *Journal of the Acoustical Society of America*, 25, 752-759.

3. Zwillocki, J. J. (1978). Masking: Experimental and theoretical

aspects of simultaneous, forward, backward, and central masking. In E. C. Carterette & M. P. Friedman (Eds.), *Handbook of perception Vol. 4: Hearing* (pp. 283-336). New York: Academic Press.

*4. Zwillocki, J. J., Damianopoulos, E. N., Buining, E., & Glantz, J. (1967). Central masking: Some steady-state and transient effects. *Perception & Psychophysics*, 2, 59-64.

Cross References

2.306 Factors affecting auditory sensitivity in the presence of masking noise;

2.309 Auditory sensitivity in noise: pure tone masking;

3.312 Auditory sensitivity in noise: nonsimultaneous masking;

Handbook of perception and human performance, Ch. 14, Sect. 3.2

2.314 Binaural Reduction of Masking: Effect of Signal Frequency and Listening Conditions

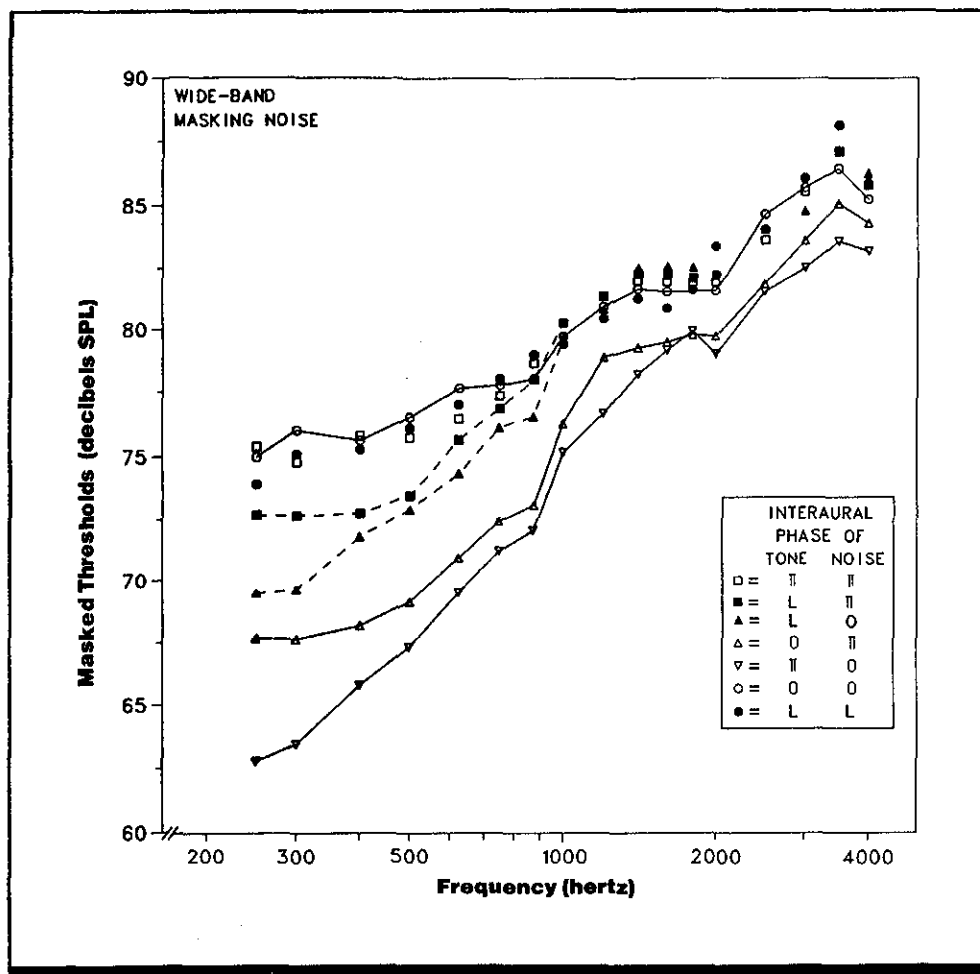

Figure 1. Masked thresholds for tones in the presence of broadband (200-4000 Hz) noise as a function of tone frequency, for various listening conditions. Types of presentation for signal and noise included: L = sound to left ear only; O = sound to both ears in phase; π = sound to both ears, inverted (180 deg out of phase) in one ear. The solid line at the top represents results for three indistinguishable conditions: both tone and noise in phase in the two ears, both tone and noise out of phase, and both tone and noise presented to left ear only. Other curves are for other listening conditions as indicated. (From Ref. 4)

Key Terms

Binaural unmasking; broadband noise; interaural phase differences; masking level difference; narrow-band noise; noise masking; remote masking; simultaneous masking

General Description

A band of noise presented simultaneously with a tone signal decreases the detectability of tones of frequencies within or near the noise-band limits, a phenomenon known as **masking**. High-intensity, high-frequency, narrow-band noise also decreases the detectability of low-frequency tones outside the usual masking limits (remote masking).

The amount of masking can be reduced by presenting the signal to only one ear and the noise to both ears, or by presenting either the signal or the noise out of phase in the two ears so that the signal and noise appear to come from

different spatial locations. The decline in the amount of noise masking when the signal and noise sources appear spatially separated is known as the *masking level difference*, or *binaural unmasking*.

For both broadband and narrow-band noise masks, the size of the masking level difference depends upon signal frequency as well as on listening conditions. For both types of mask, detectability of the masked tone is greatest at all frequencies when the signal is inverted (180 deg out of phase) in the two ears while the noise is in phase.

Applications

Improvement of signal detectability under noisy conditions; masking of unwanted sounds.

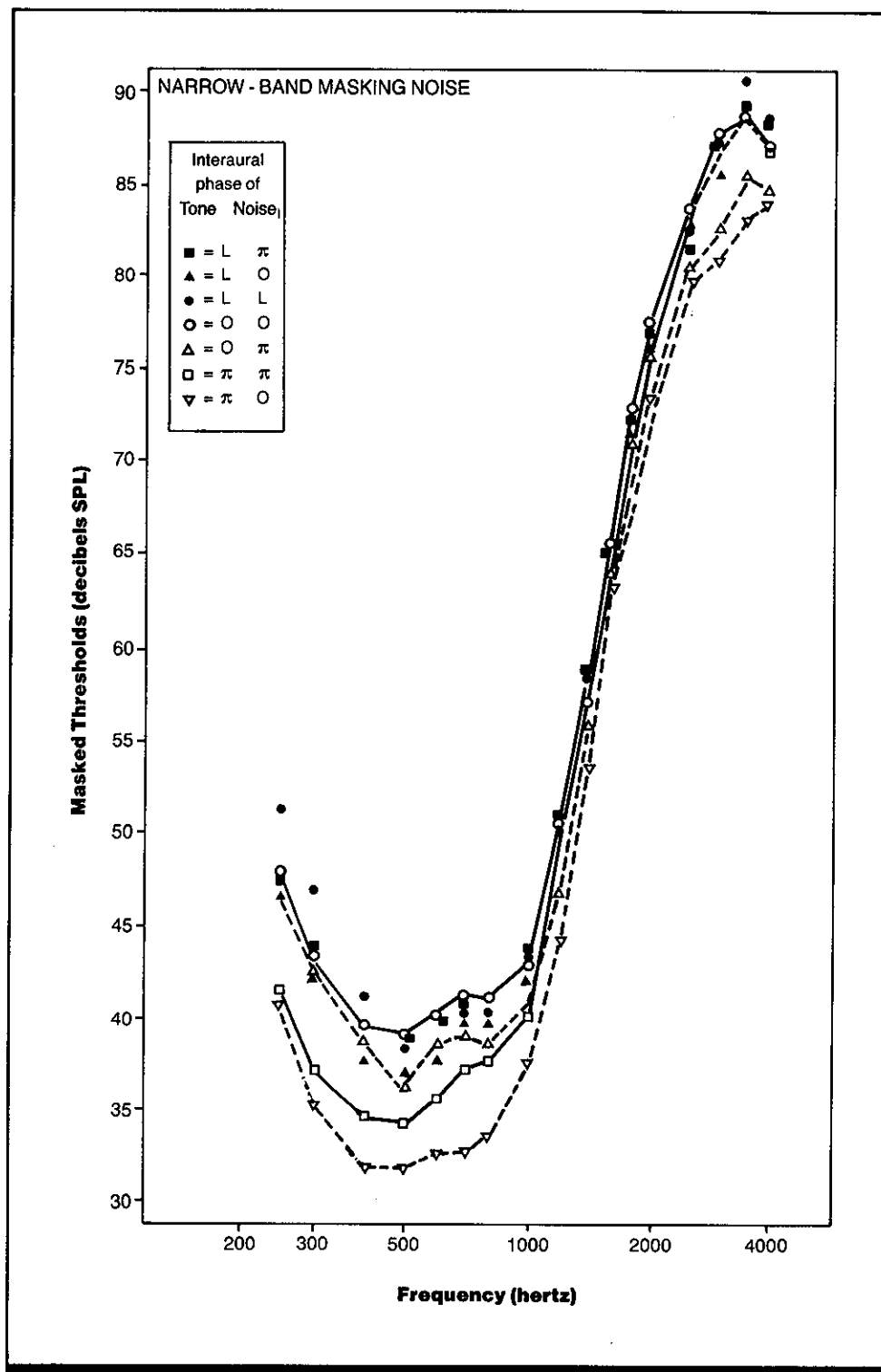

Figure 2. Masked thresholds for tones in the presence of narrow-band (2000-4000 Hz) noise as a function of tone frequency, for various listening conditions. The seven interaural phase conditions are as described in Fig. 1. (From Ref. 4)

Methods

Test Conditions

- Masks were noise bands of 200-4000 Hz (broad) and 2000-4000 Hz (narrow) with cutoffs of 36 dB per octave, generated by a random noise generator and then filtered
- Overall noise level of 96 dB sound pressure level (SPL); spectrum level 60 dB for broadband noise, 63 dB for narrow-band noise

- Signals were pure tones of 250-400 Hz with 30 msec rise and decay times, 50% duty cycles, interrupted 3 times/sec
- Stimuli presented via earphones
- Seven phase conditions: tone presented to left ear only and noise presented to left ear only, to both ears in phase, or to both ears 180 deg out of phase; tone and noise presented to both ears, both tone and noise either in phase or out of phase; both tone and noise

- presented to both ears, tone in phase while noise out of phase or vice versa
- 2 trials per phase condition per subject for each noise band
- Order of presentation of noise bands and phase conditions varied irregularly among listeners

Experimental Procedure

- Békésy tracking procedure
- Independent variables: frequency of signal, width of noise band,

- phase relations of signal and noise band between the ears and to each other, type of masking (normal or remote)
- Dependent variable: detection threshold for masked signal
- Subject's task: depress button when tone heard (to decrease signal amplitude), release when tone disappears (to increase signal amplitude)
- 4 trained subjects with clinically normal hearing

Experimental Results

- With a broadband noise mask, masked threshold increases (signal detectability decreases) as signal frequency increases.
- For all signal frequencies, the amount of masking depends on the mode of presentation of signal and noise (monaural or binaural) and the interaural phase relations of signal and noise. Masking is about equal when both signal and noise are presented monaurally and when signal and noise are presented binaurally in the same phase relation (tone and noise both in phase or both 180 deg out of phase) (Fig. 1).
- Masking is reduced (signal detectability improves) when the signal is monaural and the noise is binaural or when the interaural phase relations of signal and tone are different (Fig. 1).
- The amount of improvement increases as signal frequency decreases. The improvement in signal detectability is greatest when the signal is out of phase in the two ears while the noise is in phase (Fig. 1).

- When a tone is masked by narrow-band (2000-4000 Hz) noise, masking is greatest for signals whose frequency falls within the limits of the noise band. For tones within this frequency range, masking is least when either the signal or the noise is reversed in phase in the two ears (Fig. 2).
- Some masking also occurs for signals remote in frequency from the noise band, although such masking is substantially lower than for signals within or near the noise band limits. For signals <1000 Hz, masking is least (signal detectability is greatest) when binaural signals are reversed in phase in the two ears, regardless of whether the noise mask is in phase or out of phase.

Variability

Standard deviations were 0.82-3.66 for broadband masking and 1.16-6.26 for narrow-band masking.

Repeatability/Comparison with Other Studies

Data for broadband masking replicate an earlier experiment (Ref. 3). Results are consistent with those of other studies. Reference 2 also found a small reduction in masking with binaural listening when the noise is uncorrelated in the two ears and the signal is either in phase or out of phase.

Constraints

- Measurements are for pure-tone signals only; results are likely to be different for the complex sounds more typical of the natural environment.
- For earphone measurements, the precise threshold values obtained depend on the type of earphone used and the artificial ear used in calibrating the earphone.

- Many factors affect the detectability of a signal in the presence of masking sound and should be considered in applying these data under different conditions (CRef. 2.306).
- The size of the masking level difference also depends upon the interaural phase angle of the signal and the noise (CRef. 2.315) and the age of the listener (CRef. 8.315).

Key References

1. Durlach, N. I., & Colburn, H. S. (1978). Binaural phenomena. In E. C. Carterette & M. P. Friedman (Eds.), *Handbook of*

perception. Vol. 4: *Hearing*. (pp. 365-466). New York: Academic Press.

2. Feddersen, W. E., Sandel, T. T., Teas, D. C., & Jeffress, L. A.

(1957). Localization of high frequency tones. *Journal of the Acoustical Society of America*, 29, 988-991.

3. Hirsch, I. J. (1948). The influence of interaural phase on interaural summation and inhibition.

Journal of the Acoustical Society of America, 20, 536-544.

*4. Hirsch, I. J., & Burgeat, M. (1958). Binaural effects in remote masking. *Journal of the Acoustical Society of America*, 30, 827-832.

Cross References

2.306 Factors affecting auditory sensitivity in the presence of masking noise;

2.315 Binaural reduction of masking: effect of interaural phase differences;

8.314 Noise masking of speech: effect of interaural phase relations;

8.315 Noise masking of speech: effect of interaural phase relations for listeners of different ages;

Handbook of perception and human performance, Ch. 14, Sect. 3.2

Notes

2.315 Binaural Reduction of Masking: Effect of Interaural Phase Differences

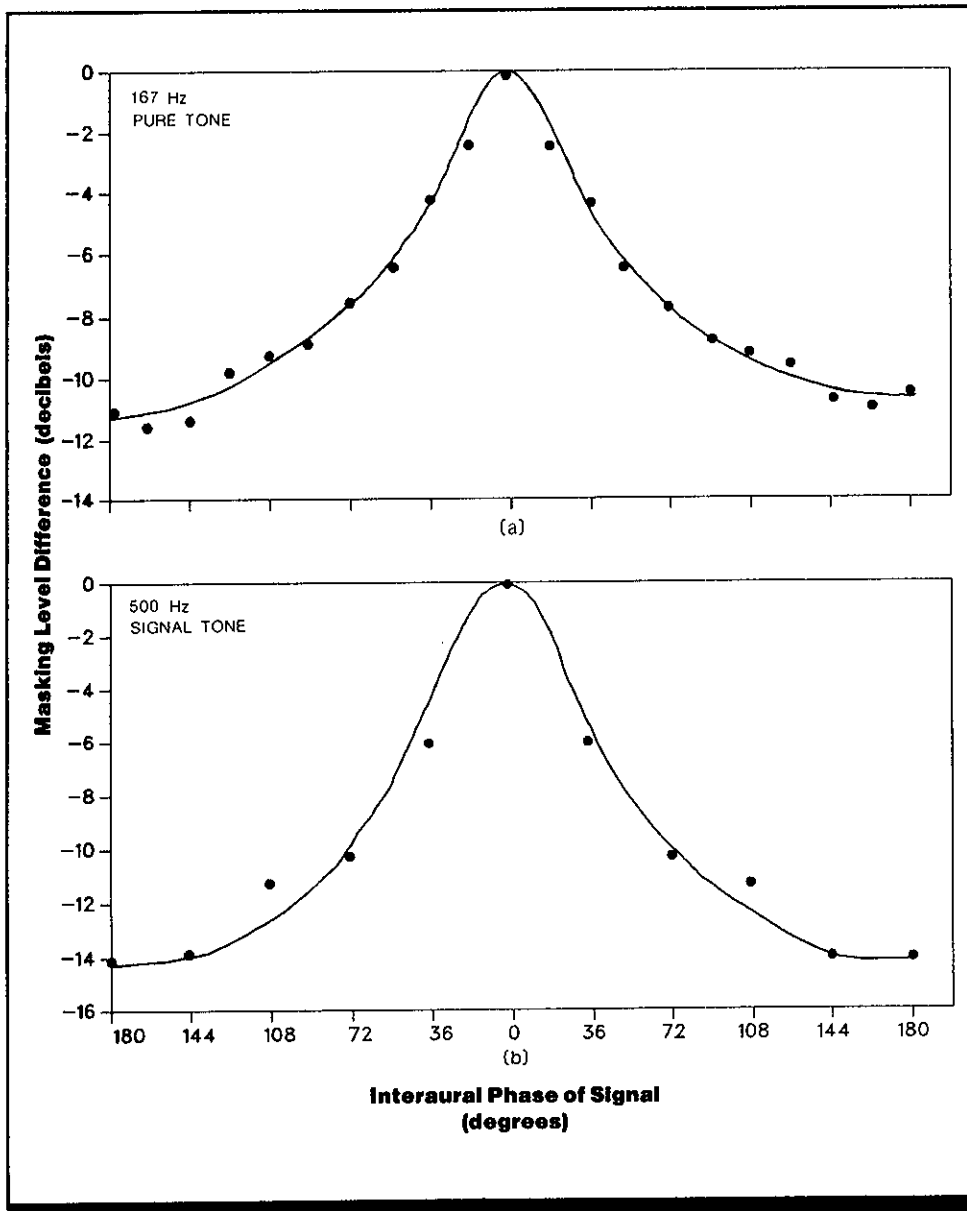

Figure 1. Masking-level difference as a function of the interaural phase of 167-Hz and 500-Hz tones presented with noise in phase at the two ears. (Masking-level difference is the difference between the masked threshold when the signal is in phase at the two ears and the masked threshold when the signal has the interaural phase difference shown on the abscissa.) (From Refs. 2, 3)

Key Terms

Binaural unmasking; broadband noise; interaural phase differences; interaural time differences; masking level difference; noise masking; signal detection

General Description

Broadband noise presented simultaneously with a tone will mask the tone (decrease its detectability). If the phase of the signal in one ear is shifted relative to the phase in the other ear, while the noise remains in phase in both ears, masking of the signal will be reduced. The difference in the detectability of a phase-shifted signal relative to the detectability of a signal that is not shifted in phase is known as the *masking-*

level difference. The masking-level difference increases as the interaural phase difference of the signal increases to 180 deg. The effects are very similar for signal tones of 167 and 500 Hz.

Masking can also be reduced by shifting the phase of the masking component of the noise (the noise component at the tone frequency) or delaying the noise to one ear, while keeping the signal in phase in the two ears.

Applications

Under noisy listening conditions, signal detection may be enhanced by changing the interaural phase of the signal or the noise (which causes signal and noise to appear to be coming from different spatial locations).

Methods

Test Conditions

- Signal was 500 or 167 Hz tone of 150 msec duration; 10 signal intensities 1.5 dB apart
- Mask was noise band of 100-2000 Hz at a spectrum level

of 60 dB sound pressure level (SPL)

- Signal phase shifted from 0-180 deg in either left or right ear relative to other ear; noise in phase
- Signals presented automatically at 3-sec intervals via PDR-10 earphones

Experimental Procedure

- Method of constant stimuli
- Independent variables: frequency of signal, interaural phase of signal
- Dependent variable: masking level difference, defined as difference in signal intensity required for 50% detection with no interaural

phase difference and with interaural phase difference of specified amount

- Subject's task: press key upon hearing signal
- Each data point represents average of several blocks of 200 trials
- 8 experienced subjects

Experimental Results

- For both 500- and 167-Hz signals, the amount of masking by broadband noise decreases as the interaural phase shift of the signal increases. Masking decreases rapidly for small phase shifts but then drops more slowly as interaural phase difference approaches 180 deg (Fig. 1).
- When the interaural phase of the 500-Hz signal and the interaural phase of the 500-Hz component of the noise are varied, masking is greatest when the phase shift of the signal matches the phase shift of the noise component, and least when the phase shift of the tone is approximately 180 deg greater or less than the phase shift of the 500-Hz noise component (data not presented here).

- Masking can also be reduced by delaying the noise to one ear while keeping the tone in phase in the two ears. Such interaural time delay of the masking noise produces much less improvement in detectability for a 167-Hz tone than for a 500-Hz tone (data not presented here).

Variability

No information on variability was given.

Repeatability/Comparison with Other Studies

Results are comparable to those obtained by Ref. 1 and a number of other studies. Reference 1 also reports similar data for other signal frequencies.

Constraints

- Measurements are for pure tone signals only; results are likely to be different for the complex sounds more typical of the natural environment.
- Many factors affect the detectability of a signal in the presence of a masking sound and should be considered in

applying these data under different conditions (CRef. 2.306).

- The amount by which masking may be reduced by altering interaural phase depends upon the frequency of the signal, the noise bandwidth, and the age of the listener (CRefs. 2.314, 8.315).

Key References

1. Hirsch, I. J. (1948). The influence of interaural phase on interaural summation and inhibition. *Journal of the Acoustical Society of America*, 20, 536-544.

*2. Jeffress, L. A., Blodgett, H. C., & Deatherage, B. H. (1952). Masking of tones by white noise as a function of the interaural phases of both components. I. 500 cycles. *Journal of the Acoustical Society of America*, 24, 523-527.

*3. Jeffress, L. A., Blodgett, H. C., & Deatherage, B. H. (1962). Masking and interaural phase. II. 167 cycles. *Journal of the Acoustical Society of America*, 34, 1124-1126.

Cross References

2.306 Factors affecting auditory sensitivity in the presence of masking noise;

2.314 Binaural reduction of masking: effect of signal frequency and listening conditions;

7.210 Selective listening: effect of the location of sound sources;

8.314 Noise masking of speech: effect of interaural phase relations;

8.315 Noise masking of speech: effect of interaural phase relations for listeners of different ages;

Handbook of perception and human performance, Ch. 14, Sect. 3.2; Ch. 26, Sect. 2.1

2.401 Intensity Discrimination of Random Noise and "Square-Wave" Noise

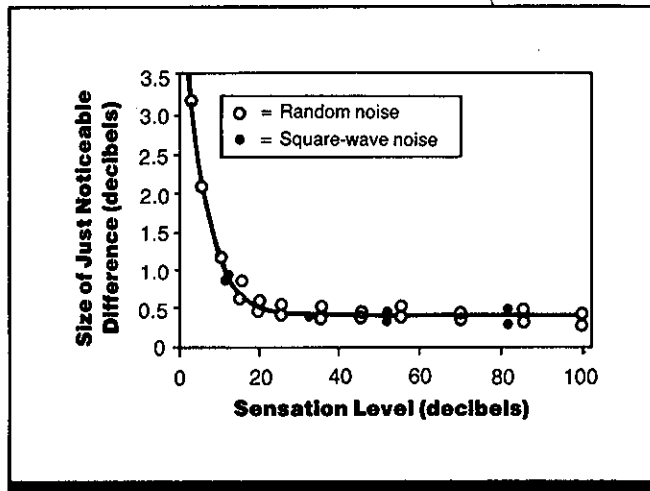

Figure 1. Just noticeable difference in intensity for white noise as a function of intensity level above threshold. The "square-wave" noise is created by peak-clipping the random noise. (From Ref. 2)

Key Terms

Intensity discrimination; peak clipping; random noise; square-wave noise

General Description

The minimum detectable intensity change (ΔI) is ~ 0.4 dB for white (random) noise and peak-clipped (square-wave) noise presented monaurally at >30 dB sensation level (SL) via an earphone.

Application

Communication systems in which the detection of small changes in signal intensity is important.

Methods

Test Conditions

- White (random) noise with uniform spectrum between 150-7000 Hz
- Peak amplitudes of random noise "squared off" at uniform level to form a square-wave noise tested for comparison

- Intensity changes made relative to subject's predetermined absolute threshold for the noise (i.e., changes made relative to sensation level)
- 16 intensities (Fig. 1); noise presented as a continuous sound with 25 identical intensity increments of 1.5-sec duration; increments pre-

sented 4.5 sec apart; proportion of increments reported for four series used to determine each of 5-8 points on a psychometric function for each intensity level and differential threshold was interpolated

Experimental Procedure

- Independent variables: type of noise, intensity

- Dependent variable: just noticeable difference in intensity, defined as the smallest intensity change heard correctly on 50% of presentations (determined by linear interpolation from psychometric functions)
- 2 subjects, with extensive practice

Experimental Results

- For noise levels above 30 dB SL, the just noticeable difference in intensity is approximately constant at 0.41 dB; differential sensitivity is poorer at lower intensity levels (Fig. 1).
- Intensity-difference thresholds are the same for white noise and square-wave noise. This result indicates that fluctuations in the peak amplitude of white noise do not influence the size of the difference threshold.

Constraints

- Results may be different for **free-field** presentation.

Key References

1. Henning, G. B. (1967). Frequency discrimination in noise. *Journal of the Acoustical Society of America*, 41, 774-777.

*2. Miller, G. A. (1947). Sensitivity to changes in the intensity of white noise and its relation to masking and loudness. *Journal of the Acoustical Society of America*, 19, 609-619.

Variability

No specific information on variability given. Data were comparable for the two subjects.

Repeatability/Comparison with Other Studies

Intensity difference thresholds for noise are of the same order of magnitude as intensity difference thresholds for pure tones, at least at the higher intensity levels.

2.501 Sensitivity to Amplitude Modulation of Broadband Noise

Key Terms

Amplitude modulation; broadband noise; intensity discrimination

General Description

The detection of **amplitude modulation** of a broadband noise is a function of the frequency and waveform of the modulation. Curves for sine-wave and square-wave amplitude modulation are approximately parallel; modulation threshold increases by ~3-4 dB per octave (sensitivity declines) as modulation frequency increases from ~50-800 Hz. In contrast, detection thresholds for pulsed amplitude modulation decrease with increasing modulation frequency.

Applications

Communication systems in which the amplitude of an auditory signal may vary. Sensitivity to amplitude modulation provides a measure of the temporal resolution of the auditory system.

Methods**Test Conditions**

- **Monaural** presentation of continuous broadband noise with a spectrum level of 40 dB sound pressure level (SPL) at 1 kHz
- Amplitude of noise modulated by a sine wave, a square wave, or a rectangular 200- μ sec pulse (Fig. 1), added to a constant noise level
- Modulation frequencies from 2-4000 Hz
- Each trial contained two 500-msec observation intervals; noise was modulated during one of the intervals; noise modulated

in 2-db steps from trial to trial

Experimental Procedure

- Staircase procedure, two-interval, forced-choice procedure
- Independent variables: frequency and type of amplitude modulation, duration of modulation (and of observation intervals)
- Dependent variable: modulation threshold, defined as modulation amplitude detected on 71% of trials; feedback provided
- Subject's task: judge which of two intervals contained amplitude modulation
- 4 subjects, with extensive practice

Experimental Results

- For sine-wave and square-wave amplitude modulation of broadband noise, modulation threshold is constant for modulation rates up to ~10 Hz, decreases by ~3 dB between 10 and 50 Hz, and then declines by 3-4 dB per octave as modulation rate increases to ~800 Hz. For modulation rates >1000 Hz and up to at least 4000 Hz, modulation threshold is roughly constant (Fig. 1a).
- The curves for sine-wave and square-wave modulation are roughly parallel (Fig. 1a). Modulation thresholds are ~2 dB lower for square-wave than for sine-wave modulations for modulation frequencies <1000 Hz, and ~3 dB lower at higher modulation frequencies.
- Dashed curves in Fig. 1 were generated by simulations with an electric model consisting of a band-pass filter followed by a half-wave rectifier, a low-pass filter, and an RMS voltmeter. The model provides a close fit to the data.
- For pulse modulation, modulation threshold decreases as modulation frequency increases (Fig. 1b).

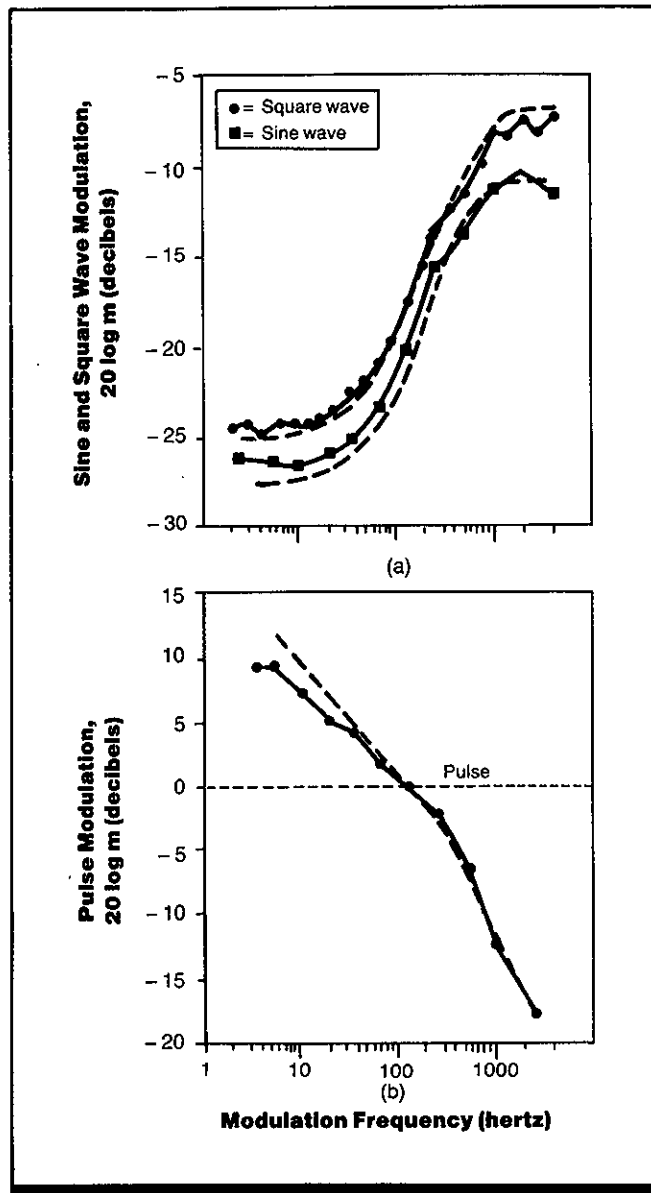

Figure 1. Detection thresholds for sine-wave, square-wave, and pulse amplitude modulation of continuous broadband noise as a function of modulation frequency. The modulation thresholds are plotted in terms of $20 \log m$, where m is the just-detectable modulation depth. Data shown are averages for two subjects. (From Ref. 3)

- Modulation threshold for sine-wave modulation decreases with increasing duration of amplitude modulation at low modulation frequencies and short durations. (Other types of modulation not tested.)

Variability

Results were similar across subjects.

Repeatability/Comparison with Other Studies

The results of sine-wave modulation experiments

(Refs. 1, 2) are consistent with a linear low-pass filter model of auditory processing (i.e., amplitude fluctuations in the auditory signal are smoothed by low-pass filtering by the auditory system), but other methods yield varying

results. The more complex multiple-stage filtering model mentioned here more accurately predicts the data for sine-wave, square-wave, and pulsed modulation (Ref. 3).

Constraints

- Results may differ for gated rather than continuous carriers, and for irregular amplitude modulations.

Key References

1. Riesz, R. R. (1928). Differential intensity sensitivity of the ear. *Physical Review*, 31, 867-875.

2. Terhardt, E. (1974). On the perception of periodic sound fluctuations (roughness). *Acustica*, 30, 201-213.

*3. Viemeister, N. F. (1979). Temporal modulation transfer functions based upon modulation thresholds. *Journal of the Acoustical Society of America*, 66, 1364-1380.

Cross References

Handbook of perception and human performance, Ch. 14, Sec. 4.3.1

2.502 Detection of Gaps in Continuous Noise

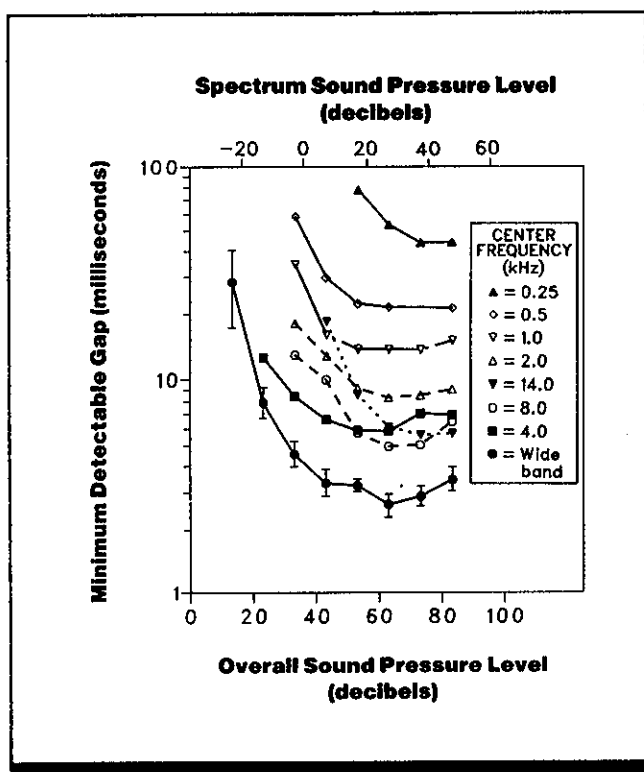

Figure 1. Gap detection thresholds as a function of level and frequency. The just-detectable duration of a brief pause (a gap) in an otherwise continuous noise is plotted as a function of overall sound pressure level of the noise for octave-band noise of different center frequencies. The spectrum level is shown on the top axis. (From Ref. 2)

Key Terms

Broadband noise; gap detection; narrow-band noise

General Description

The detection of a brief pause or gap in an otherwise continuous noise depends upon the intensity level of the noise and the center frequency of the noise band. The smallest detectable gap decreases rapidly with increasing noise intensity

level up to 50-60 dB sound pressure level (SPL), and is relatively constant above that level. Gap detection threshold decreases as the center frequency of the noise band increases from 0.25-14 kHz.

Applications

Communication systems in which interruptions may occur in the flow of auditory information. Gap detection thresholds provide a measure of the temporal resolution of the auditory system.

Methods**Test Conditions**

- Octave bands of noise with center frequencies of 0.25-14 kHz, plus broadband, low-pass filtered noise
- Overall SPL of noise varied from 10-90 dB

- Presence of complementary continuous band-stop masks (equal to signal in spectrum level) controlled cues from rapid-onset effects (spectral splatter)
- Gaps produced by turning otherwise continuous noise on-off with rise-fall times of 1 msec

- Trials of two 500-msec observation intervals delimited by light and separated by 500 msec; gap present during one of the two intervals

Experimental Procedure

- Two-interval, two-alternative, forced-choice procedure; feedback provided

- Independent variables: intensity of noise, center frequency of noise band
- Dependent variable: minimum gap detected
- Subject's task: judge which of two intervals contained gap
- 3 subjects

Experimental Results

- For noise bands of all center frequencies, minimum detectable gap decreases as noise intensity increases up to an overall noise level of 50-60 dB SPL.
- The duration of the smallest detectable gap decreases by a factor of 10 as the center frequency of the noise band increases from 0.25-14 kHz.

Variability

Vertical bars in the figure show ± 1 standard deviation.

Repeatability/Comparison with Other Studies

Other studies have found that minimum detectable gap in a continuous noise decreases linearly with a slope of ~ 2 msec per octave (Refs. 1, 3). The patterns of results support the theory that a peripheral auditory filter primarily determines short-term temporal resolution (as in gap detection).

Key References

1. Fitzgibbons, P. J. (1983). Temporal gap detection in a noise as a function of frequency, bandwidth, and level. *Journal of the Acoustical Society of America*, 74, 67-72.
- *2. Florentine, M., & Buus, S. (1983). Temporal acuity as a function of level and frequency. *Proceedings of the 11th International Congress on Acoustics*, (Vol. 3, pp. 103-106). Paris: Groupement des Acousticiens de Langue Française.
3. Shailer, M. J., & Moore, B. C. J. (1983). Gap detection as a function of frequency, bandwidth, and level. *Journal of the Acoustical Society of America*, 74, 467-473.

Cross References

- 2.503 Discrimination of event duration;
- 6.408 Auditory perception of sequence: effect of interstimulus onset interval;
- Handbook of perception and human performance*, Ch. 14, Sect. 4.3

2.503 Discrimination of Event Duration

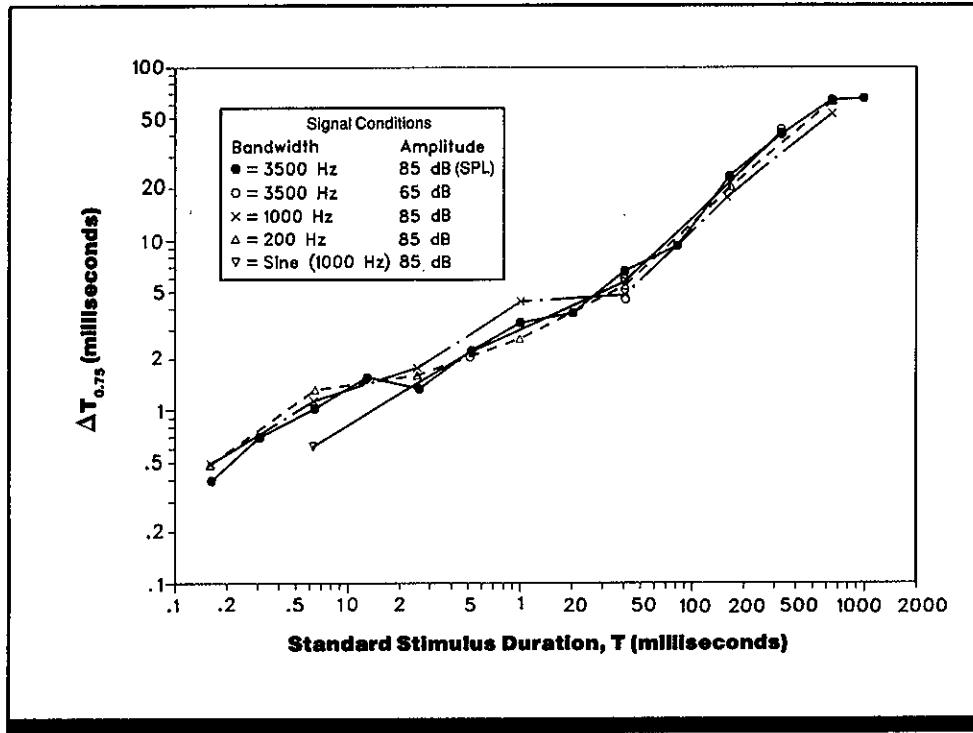

Figure 1. Mean detectable difference (ΔT) in the duration of noise bursts and gated sinusoids as a function of stimulus duration (Study 1). Data are shown for stimuli of various amplitudes, bandwidths, and waveform. (From Ref. 1)

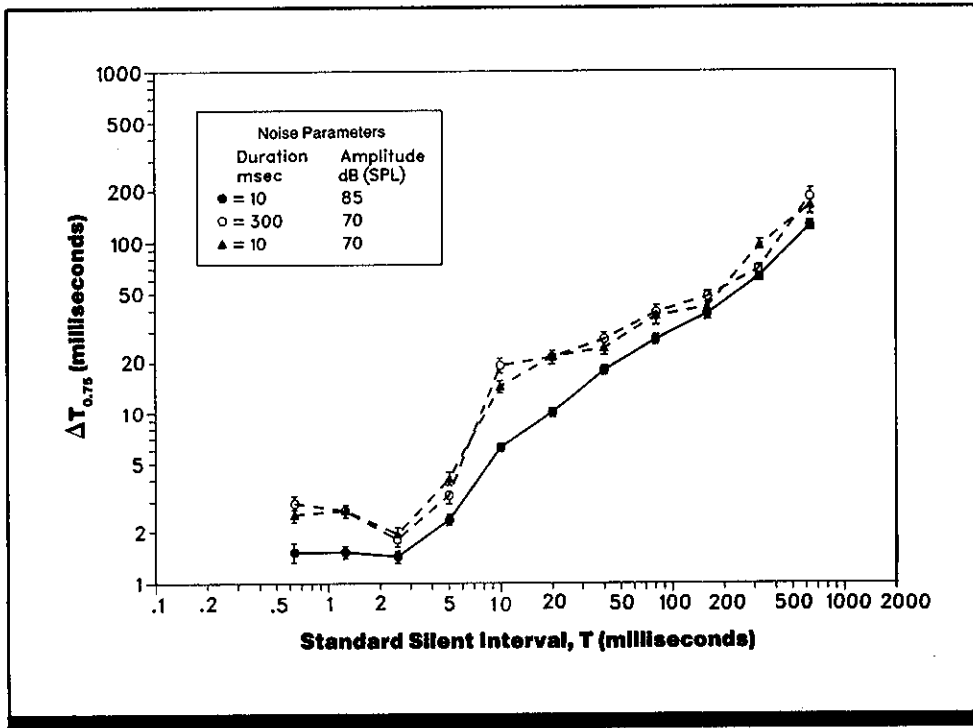

Figure 2. Mean detectable difference (ΔT) in the duration of silent intervals (gaps) as a function of gap duration (Study 2). Data are shown for these different types of gap markers differing in duration and amplitude. (From Ref. 2)

Key Terms

Duration difference threshold; duration perception; event duration; gap detection; temporal discrimination

General Description

When listeners must detect small differences in the duration of noise bursts or gated sinusoids, the size of the smallest detectable difference increases as stimulus duration increases. This increase is independent of stimulus amplitude or noise bandwidth (within a small range of amplitudes). When listeners must detect small differences in the duration

of silent intervals (gaps) marked (delimited) by noise bursts, the size of the smallest detectable difference in gap length increases as gap duration increases, when gap duration is >2.5 msec. For gap durations <160 msec, characteristics of the noise marker influence the results; brief, higher-intensity noise markers yield better gap discrimination than do longer, lower amplitude noise markers.

Applications

Communication systems in which the duration of brief signals must be discriminated or in which interruptions may occur in the flow of auditory information. Discrimination of differences in duration provides a measure of the temporal resolution of the auditory system.

Methods

Test Conditions

- Binaural presentation via earphones in a sound-treated room

Study 1 (Ref. 1)

- Test trial intervals signaled by a warning light
- Standard (fixed) and comparison (variable) stimuli presented in intervals 500 msec apart
- Stimulus duration from 0.16-960 msec in 14 random steps
- Stimulus types: (1) low-pass-filtered (4 kHz) noise bursts at 85 dB sound pressure level (SPL) for 14 standard durations from 0.16-1000 msec; (2) same noise spectrum at 65 dB for 5-, 40-, or

320-msec duration; (3) low-pass filtered (1 kHz) noise bursts at 85 dB for standard deviations of 0.16, 0.63, 2.5, 10, 40, 160, or 640 msec; (4) band-pass filtered (0.9-1.1 kHz) noise bursts at 85 dB for standard durations of 0.16, 0.63, 2.5, 10, 40, 160, or 640 msec; (5) unfiltered randomly phased, gated sinusoid (1000 Hz) at 85 dB for standard durations of 0.63, 5, 40, or 320 msec

Study 2 (Ref. 2)

- Standard and comparison silent gaps presented in intervals 500 msec apart
- Standard gap durations from 0-640 msec in 11 equal log steps
- Seven comparison gaps for each

standard gap; shortest comparison gap 1 msec shorter than standard

- Gaussian noise bursts of 0-20 kHz marked gap boundaries; noise marker duration 10 or 300 msec
- Types of noise marker: (1) 10-msec noise burst at 85 dB SPL; (2) 300-msec noise bursts at 70 dB (equal in energy to first condition); (3) 10-msec noise burst at 70 dB (15 dB lower in energy)

Experimental Procedure

- Method of constant stimuli, two-interval forced-choice procedure; feedback provided
- Independent variables: stimulus duration, bandwidth, amplitude

(Study 1); gap duration, duration and amplitude of noise burst serving as gap marker (Study 2)

- Dependent variables: just noticeable difference in stimuli duration, defined as increase in duration discriminable on 75 percent of trials (Study 1); just noticeable difference in gap duration, defined as increase in gap duration discriminable on 75 percent of trials (Study 2)
- Subject's task: indicate interval containing longer sound (Study 1) or longer gap (Study 2)
- 2 subjects, college undergraduates with extensive practice (Study 1); 3 undergraduates, 2 with extensive practice (Study 2)

Experimental Results

- The smallest detectable differences in the duration of a burst of sound increases as the duration of the sound increases. Changes in duration discrimination thresholds with stimulus duration can be well described by a line with a slope of 0.5 for durations <50 msec and by a line with a slope of 1.0 for durations >50 msec (Fig. 1).
- The discrimination of the duration of noise bursts is independent of signal bandwidth, amplitude, and waveform for the values of these parameters tested (Fig. 1).
- The smallest detectable difference in gap duration is roughly constant at ~ 2 msec for gap durations <5 msec. For durations >5 msec, discrimination threshold increases with gap duration (Fig. 2).
- Discrimination threshold for gap duration is affected by

the characteristics of the gap marker when gap duration is <160 msec (Fig. 2); short, high-intensity noise markers (10 msec, 85 dB) result in better gap discrimination than do longer markers with equal energy (300 msec, 70 dB) and same length signals with lower amplitude (10 msec, 70 dB).

Variability

Standard error of mean discrimination threshold is $<10\%$ for discrimination of duration (Fig. 1). Vertical bars in Fig. 2 indicate ± 1 standard error of the mean.

Repeatability/Comparison with Other Studies

Duration discrimination thresholds for noise bursts and silent intervals are similar to those obtained for the discrimination of the duration of equal-loudness noise bursts and gated sinusoids (Ref. 3).

Constraints

- Stimulus conditions were always blocked and presented in the same order in both studies; the duration difference for gaps always decreased within each block of seven trials (per

standard gap) (Study 2). Discrimination thresholds might be slightly higher when conditions are completely randomized. Results may differ when gap is surrounded by more than single markers at onset and offset.

Key References

*1. Abel, S. M. (1972). Discrimination of temporal gaps. *Journal of the Acoustical Society of America*, 52, 519-524.

*2. Abel, S. M. (1972). Duration discrimination of noise and tone bursts. *Journal of the Acoustical Society of America*, 51, 1219-1223.

3. Small, A. M., & Campbell, R. A. (1962). Temporal differential sensitivity for auditory stimuli. *American Journal of Psychology*, 75, 401-410.

Cross References

2.502 Detection of gaps in continuous noise;
6.408 Auditory perception of se-

quence: effect of interstimulus onset interval;

Handbook of perception and human performance, Ch. 14, Sect. 4.3

2.504 Perceived Event Duration: Effect of Complexity and Familiarity

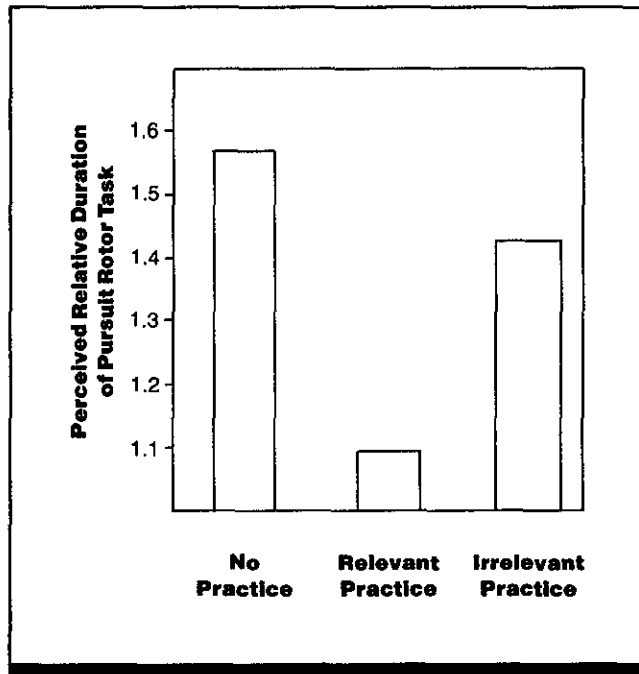
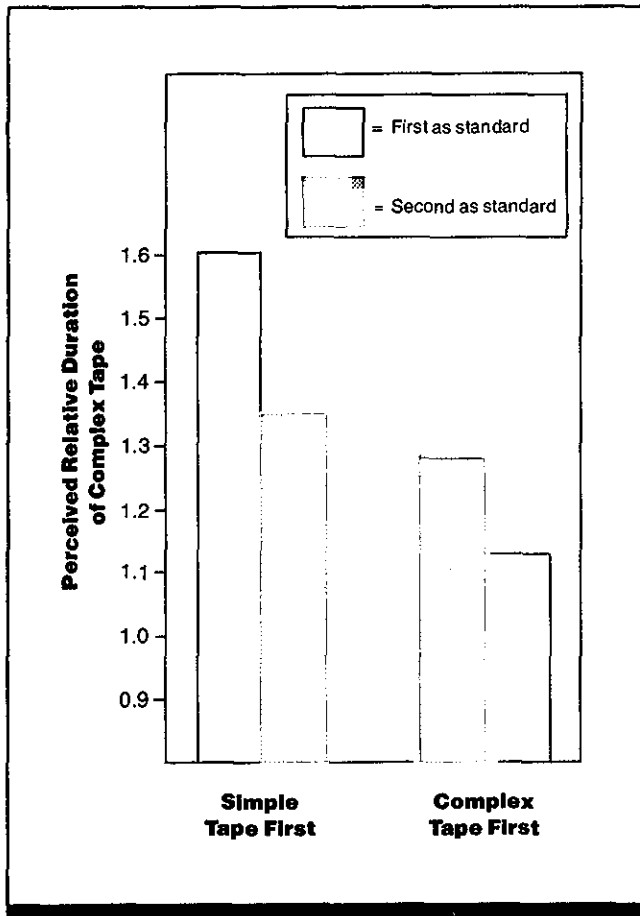

Figure 1. Judged duration of complex (random) audio tape of identifiable sounds relative to duration of simple (non-random) tape, as a function of which tape was presented first and which tape was designated as time standard (Study 1). (Values >1.00 indicate that complex tape appeared longer.) (Based on data from Ref. 4)

Figure 2. Judged duration of pursuit rotor task relative to duration of complex audio tape for three practice conditions (Study 2). (Values >1.00 indicate that the pursuit rotor task appeared longer than the audio tape.) Subjects had previous practice on the pursuit rotor task (relevant practice), practice on a different task (irrelevant practice), or no practice. (Based on data from Ref. 4)

Key Terms

Duration perception; event duration; temporal discrimination

General Description

The complexity and familiarity of stimulus events influence the perceived duration of an event or interval. In general, an interval containing complex or unfamiliar events appears longer than an interval containing simpler or more familiar events.

Methods

Test Conditions

Study 1

- 5-min audio tapes consisting of 10 identifiable sounds (e.g., typewriter keystroke, zipper, tearing paper)
- Each sound repeated 20 times successively (simple tape) or 20 times in random order (complex tape)

Study 2

- Audio tape as in Study 1, con-

sisting of identifiable sounds presented in random order

- Subjects (a) practiced a relevant (pursuit rotor) or irrelevant task for 7 min or did not practice a task; then (b) listened to the audio tape for 2 min; then (c) performed the pursuit rotor task for 2 min

Experimental Procedure

Study 1

- Magnitude estimation
- Independent variables: complexity of tape; tape presented first (simple or complex), tape desig-

nated as standard (simple or complex)

- Dependent variable: perceived relative duration of comparison tape, measured as ratio of subject-produced line to 50-mm line representing length of standard tape
- Subject's task: draw a line representing duration of tape designated as comparison relative to duration of tape designated as standard
- 24 subjects

Study 2

- Magnitude estimation

- Independent variable: practice condition (relevant, irrelevant, none)
- Dependent variable: perceived relative duration of last pursuit rotor task interval, measured as ratio of line drawn by subject to represent duration of pursuit rotor task compared to standard line of 50 mm which represented duration of audio tape presentation
- Subject's task: draw line to represent duration of pursuit rotor test compared to duration of tape presentation
- 30 subjects

Experimental Results

- A complex audio tape (in which repetitions of identifiable sounds are presented in random order) is perceived to be 1.33 times longer, on average, than a simple tape (repetitions of the same sounds are grouped together) of the same objective duration ($p < .02$).
- The complex tape is perceived as lasting longer when the simple tape is played before the complex one (ratio of 1.45) than when the simple tape is played after the complex one (ratio of 1.20), a significant order effect ($p < .05$).

- Which tape is designated as the time standard has no effect.
- When the perceived duration of a pursuit rotor task is compared to the duration of a complex audio tape of the same objective length, subjects with previous practice on the pursuit rotor task judge the rotor task interval to be significantly shorter than do subjects who have no practice or practice on a different task ($p < .05$).

Variability

Significance of the variables was assessed using *t*-tests.

Constraints

- Familiarity and complexity are not always well defined.
- Subjects were unaware that they would have to judge the duration of the sound tapes or tasks. Duration judgments likely to be different when subjects attend to duration in making such judgments.

Key References

1. Coren, S., Porac, C., & Ward, L. (1979). *Sensation and perception*. New York: Academic Press.

2. Frankenhaeuser, M. (1959). *Estimation of time, an experimental study*. Stockholm: Almqvist & Wiksell.

3. Matsuda, F. (1966). Development of time estimation: Effects of frequency of sounds given during standard time. *Japanese Journal of Psychology*, 36, 285-294.

*4. Ornstein, R. E. (1969). *On the experience of time*. New York: Penguin Books.

Cross References

2.503 Discrimination of event duration;

6.408 Auditory perception of sequence: effect of interstimulus onset interval

2.601 Factors Influencing Loudness

Key Terms

Auditory masking; bandwidth; binaural presentation; frequency; interaural phase differences; loudness adaptation; monaural presentation; sound intensity; tone intermittency

General Description

Although the terms "loudness" and "intensity" are often treated as synonymous, the two terms refer to different properties of sound. Intensity is a physical property of sound (the rate of energy transfer), while loudness is a subjective property (the magnitude of a sensation, i.e., the *per-*

ceived intensity of a sound). Although loudness generally increases with sound intensity, the two are not perfectly correlated. The table lists some factors that affect loudness, briefly describes the nature of the effects, and cites entries where more information can be found.

Constraints

- Interactions may occur among various factors affecting loudness.
- There are individual differences in judged loudness.

Factor	Effect of Loudness	Reference
Sound pressure level (SPL)	Loudness of a pure tone increases with SPL, following a simple power function. For white noise below ~60 dB, loudness increases more rapidly than for a pure tone ; for white noise above ~60 dB, loudness increases more slowly	CRef. 2.602
Frequency	As low-frequency (less than ~1000 Hz) tones increase in SPL, loudness increases more quickly than for high-frequency tones. The SPL necessary to achieve a given loudness level is lowest for tones in the range of ~1000-3000 Hz.	CRef. 2.603
Bandwidth	Loudness of an intense complex sound is constant as bandwidth increases to a critical value; beyond the critical value, loudness increases with bandwidth; at low intensity, loudness is independent of bandwidth. The growth of loudness with increasing intensity is most rapid for uniform noise with largest dispersion of component frequencies, less rapid for uniform-spectrum noise with moderate frequency dispersion, and least rapid for pure tones.	CRef. 2.604 CRef. 2.605
Duration	Up to ~70-100 msec, loudness increases with duration such that for constant loudness, intensity \times duration is roughly constant.	CRef. 2.607
Presence of masking stimulus	As the level of a masking sound increases, loudness of the signal increases more rapidly with SPL. When the level of a masking sound is <80 dB, a signal sounds as loud in noise as in quiet when it is 20-30 dB above its masked threshold. With a more intense masking noise, loudness does not reach the full unmasked value for that signal. Tones with frequencies higher than a masking tone increase more rapidly in loudness with SPL than tones equally distant below the masking tone.	CRef. 2.611

Factor	Effect of Loudness	Reference
Tone intermittency	<p>The combined loudness of two tones bursts is greater than either burst alone if they are separated by an interval of <25-200 msec. With separations below ~500 msec, loudness of the second tone burst is elevated by preceding it with a more intense tone burst.</p> <p>For pulse rates of two pulses per sec or more, a pulse train is louder than a continuous sound of equal overall energy, but softer than a continuous sound of equal intensity.</p>	CRef. 2.610
Interaural phase	<p>Interaural phase affects loudness judgments when a subject must separate signal from background noise at signal-to-noise ratios near masked threshold.</p>	CRef. 2.609
Adaptation	<p>Loudness generally does not decrease with prolonged exposure.</p> <p>Adaptation will occur if a tone is a steady sound within ~30 dB of threshold, or if a steady tone is intermittently increased in intensity or is accompanied by an intermittent sound of higher intensity.</p>	CRef. 2.612
Monaural versus binaural presentation	<p>A sound presented to both ears is louder than the same sound presented to one ear.</p>	CRef. 2.608

Key References

*1. Scharf, B., & Houtsma, A. (1986). Audition II: Loudness, pitch, localization, aural distortion, pathology. In K. R. Boff, L. Kauf-

man, & J. P. Thomas (Eds.), *Handbook of perception and human performance: Vol. 1. Sensory processes and perception* New York: Wiley.

2. Stevens, S. S. (1951). *Handbook of experimental psychology*. New York: Wiley.

3. Stevens, S. S. (1975). *Psychophysics*. New York: Wiley.

Cross References

2.602 Effect of sound pressure level on loudness;
 2.603 Effect of frequency on the loudness of pure tones;
 2.604 Effect of bandwidth on the loudness of two-tone complexes;

2.605 Effect of bandwidth on the loudness of broadband and moderate-band noise;
 2.607 Effect of duration on the loudness of narrow-band noise;
 2.608 Monaural versus binaural loudness;

2.609 Effect of interaural phase on the loudness of masked tones;
 2.610 Loudness of intermittent stimuli;
 2.611 Loudness reduction under masking by broadband noise and narrow-band noise;
 2.612 Loudness adaptation

2.602 Effect of Sound Pressure Level on Loudness

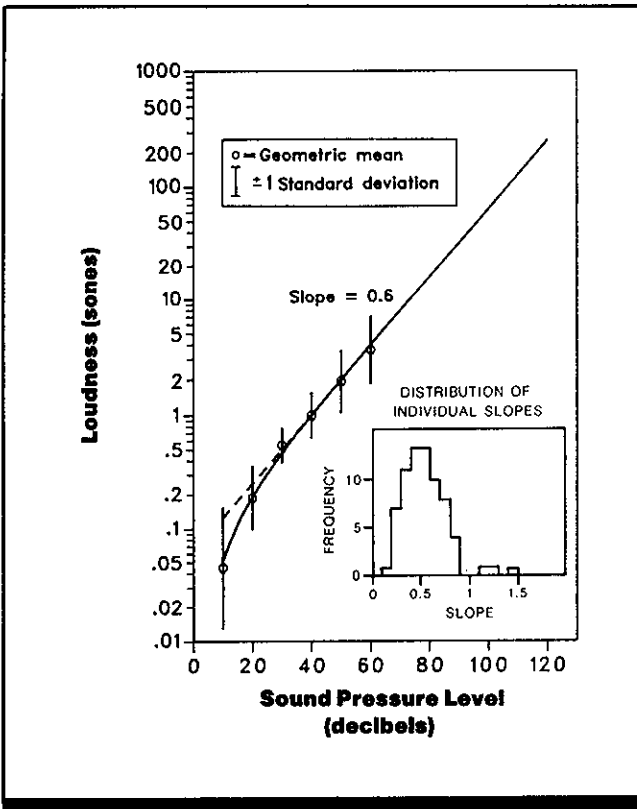

Figure 1. Loudness function for a 1,000-Hz tone. Loudness in sones is plotted as a function of the sound pressure level in decibels. The straight portion of the solid line is from the international standard for a 1,000-Hz tone (Ref. 2) and has a slope of 0.6. The curved portion was taken from Ref. 4 and is based on a number of studies near threshold. The data points are from Study 1 (Ref. 1) and are means for 70 subjects. Curves fitted to individual data by the method of least squares yielded the 70 slopes plotted in the inset. The mean of these individual slopes is 0.6, and the slope of the best fitting curve through the geometric means is 0.55. (From Handbook of perception and human performance)

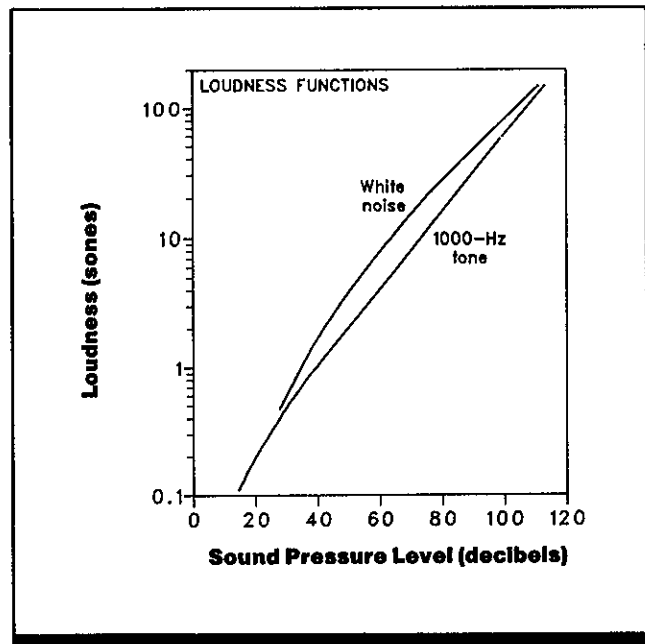

Figure 2. Loudness function for white noise (Study 2). Function for a 1000-Hz tone (taken from Fig. 1) is shown for comparison. Curve for white noise fitted to the geometric means of magnitude estimation and magnitude production data. (From Ref. 5)

Key Terms

Sensation magnitude; sound intensity; white noise

General Description

The loudness of a pure tone increases as sound pressure level (SPL) increases. This relationship follows a simple power law; plotted on log-log coordinates, the relationship

is expressed as a straight line. Loudness functions for white noise are concave downward on log-log coordinates; up to ~60 dB, loudness for white noise grows more rapidly than for a pure tone and above ~60 dB loudness for white noise grows more slowly.

Methods

Test Conditions

Study 1 (Ref. 1)

- 1000-Hz tone presented via loudspeaker located ~3 m from subject in anechoic chamber
- Subjects run in groups of 4-11

Study 2 (Ref. 5)

- White noise presented binaurally via earphones
- SPL varied from 40-110 dB

Experimental Procedure

Study 1

- Method of magnitude estimation
- Independent variable: SPL in dB

(measured where the center of the subject's head would be if subject were present)

- Dependent variable: judged loudness in sones
- Subject's task: estimate loudness of tone
- 70 naive subjects

Study 2

- Methods of magnitude estima-

tion and magnitude production (adjust loudness to match number from 1-160 given by experimenter)

- Independent variable: SPL in dB
- Dependent variable: judged loudness in sones, taken as geometric mean of estimation and production data at each SPL
- 15 subjects

Experimental Results

- Above ~30 dB SPL, the increase in loudness of a 1000-Hz tone can be expressed as a power function, $L = 0.01 (P - P_0)^{0.6}$, where L = loudness in sones, P = sound pressure in micropascals (μPa), and P_0 = the effective threshold at which loudness first increases with sound pressure (~45 μPa). (The subtractive constant is included to reflect the curvature of the loudness function at low levels.) The exponent, 0.6, indicates that loudness doubles whenever sound pressure level increases by 10 dB.
- Below ~30 dB SPL, the function for the 1000-Hz tone is slightly concave downward (Fig. 1).

- Loudness of white noise grows more rapidly than loudness of a 1000-Hz tone near threshold, but grows more slowly above 60 dB (Fig. 2).

Variability

Bars in Fig. 1 show one standard deviation for data of Study 1. In Study 2, interquartile ranges were ~50% of the geometric mean at a given SPL for the magnitude estimation data and 10 dB for the production data.

Repeatability/Comparison with Other Studies

Similar data have been reported in other studies.

Constraints

- Many factors influence judged loudness and must be considered in applying these results under different conditions (CRef. 2.601).
- There are individual differences in judged loudness.

Key References

*1. Canévet, G., Hellman, R. P., Marchioni, A., & Scharf, B. (1983). Estimations de sonie en champ libre et semi-réverbérant. *Proceedings of the International Congress on Acoustics, 11th*

(Vol. 3, pp. 87-90). Paris: Groupe-ment des Acousticiens de Langue Francaise.

2. International Organization for Standardization. (1966). *Method for calculating loudness level* (ISO-R 532). New York: ISO.

3. Marko, L. E. (1979). A theory of loudness and loudness judgments. *Psychological Review, 86*, 256-285.

4. Scharf, B. (1978). Loudness. In E. C. Carterette, & M. P. Friedman (Eds.), *Handbook of perception*.

Vol. IV: Hearing (pp. 187-242). New York: Academic Press.

*5. Scharf, B., & Fishken, D. (1970). Binaural summation of loudness: Reconsidered. *Journal of Experimental Psychology, 86*, 374-379.

Cross References

2.601 Factors influencing loudness;
Handbook of perception and human performance, Ch. 15, Sect. 1.2

2.603 Effect of Frequency on the Loudness of Pure Tones

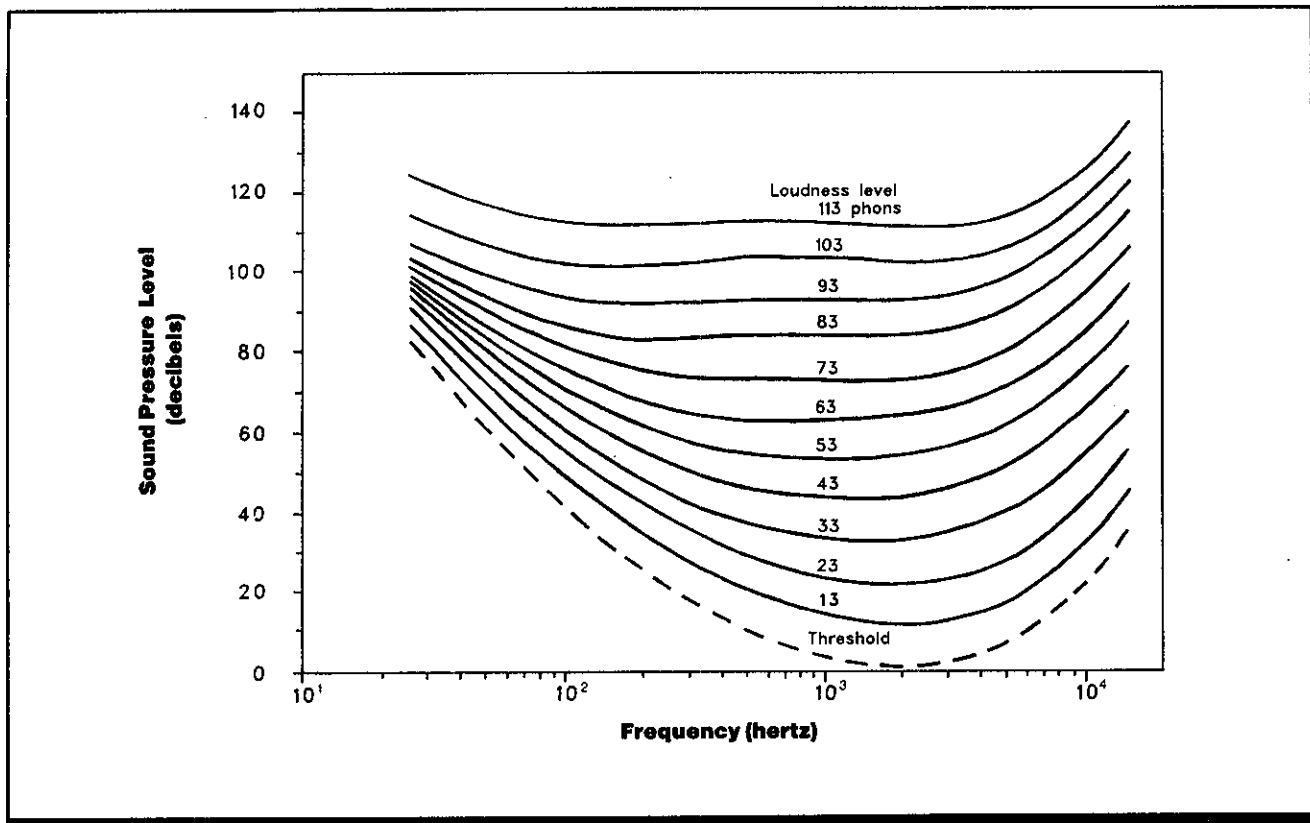

Figure 1. Equal-loudness contours for pure tones presented through a pair of earphones (Study 1). The vertical axis shows the sound pressure level (SPL) at which a tone of the frequency given on the horizontal axis sounded equal in loudness to a 1000-Hz reference tone of the loudness level shown on each curve. Curves were drawn through the median points of the data and then smoothed. A given contour gives the combinations of frequency and sound pressure level that yield the loudness level indicated on that contour. The bottom curve differs from the others and shows threshold for tones of each frequency. (From Ref. 5, data from Ref. 1)

Key Terms

Frequency; sound intensity

General Description

The loudness level of a pure tone is influenced by the frequency of the tone as well as its physical intensity. As low-frequency tones (those below ~ 1000 Hz) become more intense, their loudness grows faster than that of tones of higher frequencies. At a given sound pressure level, loudness is greatest for tones in the middle frequency range.

Applications

Construction of a loudness function (change in loudness with a change in sound pressure level) for a tone of given frequency.

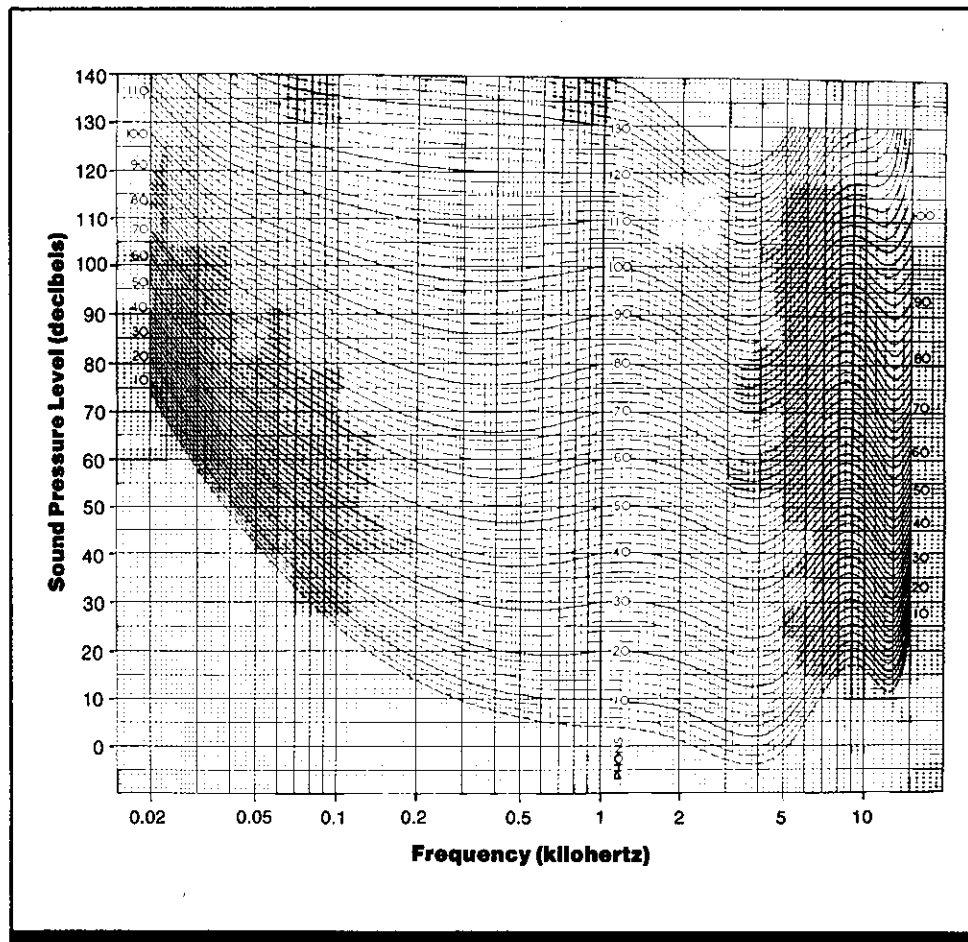

Figure 2. Equal-loudness contours for pure tones presented in a free field (Study 2). The meaning of the vertical and horizontal axes and loudness level parameter are the same as for Fig. 1. Bottom dashed contour represents threshold. The contours in this figure serve as the international standard. (From Ref. 3)

Methods

Test Conditions

Study 1 (Ref. 1)

- Pure tones between 200-1000 Hz presented binaurally through earphones
- 100-msec rise-fall times

Study 2 (Ref. 3)

- Pure tones presented binaurally in free field

Experimental Procedure

Study 1

- Threshold measurements at each frequency obtained with method of limits; method of constant stimuli used for other measurements
- 1-sec test tone of given frequency followed 0.5 sec later by 1-sec 1000-Hz reference tone; two presentations of each tone pair
- Independent variables: frequency of test tone, loudness level of 1000-Hz reference tone

- Dependent variable: sound pressure level (SPL) of the test tone that sounded equal in loudness to 1000-Hz reference tone
- Subject's task: judge whether the reference tone was louder or softer than the test tone
- 11 experienced subjects

Study 2

- Methods, variables, and task similar to those for Study 1
- 30 subjects, ages 18-25

Experimental Results

- At low frequencies (<1000 Hz), equal-loudness contours show a rapid increase in sound pressure level (SPL) as frequency decreases with both free-field and earphone presentation. The distance between the contours also decreases; this indicates that, as low-frequency tones increase in intensity, their loudness grows faster than that of mid- and high-frequency tones.
- Above 1000 Hz, the free-field equal-loudness contours show a minimum at 3000-4000 Hz and a peak at 8000-9000 Hz. The irregular shape of the contours at the higher frequencies is caused by diffraction around the head.
- At frequencies greater than ~4000 Hz, equal-loudness contours for both earphone and free-field presentation show a general increase in SPL as frequency increases and a similar, constant distance between curves.
- Using the data in Fig. 1, loudness is plotted as a function

of SPL in Fig. 3 for selected frequencies. At lower SPL, the loudness functions are progressively steeper as frequency decreases below 1000 Hz (i.e., loudness of low frequency tones increases more rapidly); however, the curves are superimposed at high SPL.

Variability

In Study 1, the standard error of the mean was 1-2 dB; the variability was slightly smaller when the test frequency was near 1000 Hz than when it was more distant. In Study 2, variability also depended on the difference between the test tone and 1000-Hz reference tone as well as on loudness level, and ranged from 5-10 phons.

Repeatability/Comparison with Other Studies

Similar equal loudness contours have been reported with various procedures.

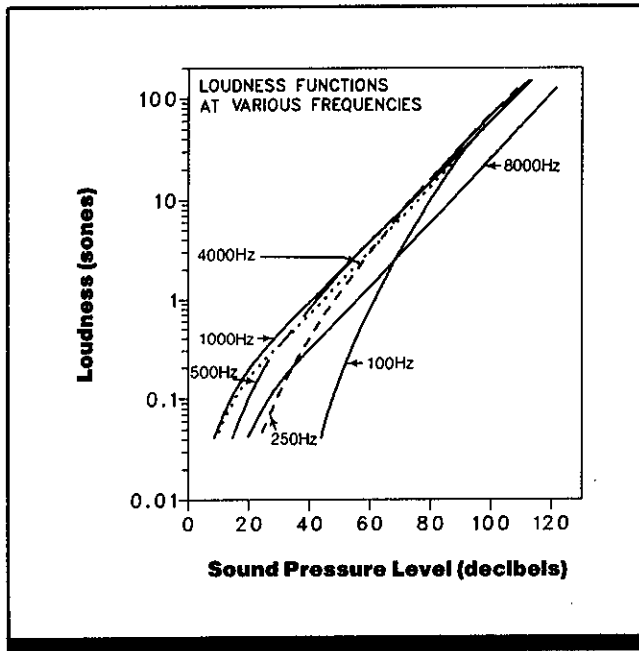

Figure 3. Loudness of pure tones at frequencies from 100-8000 Hz as a function of the sound pressure level of the tones. Loudness function for 1000-Hz tone is from Fig. 1, Entry 2.602; functions for the other frequencies are derived from Fig. 1. (From Ref. 4)

Constraints

- Many factors influence judged loudness and must be considered in applying these results under different conditions (CRef. 2.601).
- There are individual differences in judged loudness.
- Loudness functions may differ somewhat if narrow-band noise rather than a pure 1000-Hz tone is used as a reference.

Key References

- *1. Fletcher, H. F., & Munson, W. A. (1933). Loudness, its definition, measurement and calculation. *Journal of the Acoustical Society of America*, 5, 82-108.
2. International Organization for Standardization (ISO). (1962). *Normal equal-loudness contours*

- for pure tones and normal threshold of hearing under free field listening (ISO R-226). Switzerland: ISO.
- *3. Robinson, D. W., & Dadson, R. S. (1956). A redetermination of the equal-loudness relations for pure tones. *British Journal of Applied Physics*, 7, 166-181.

4. Scharf, B. (1978). Loudness. In E. C. Carterette & M. P. Friedman (Eds.), *Handbook of perception* (Eds.), *Handbook of perception Vol. 4: Hearing* (pp. 187-242). New York: Academic Press, Inc.
5. Scharf, B., & Houtsma, A. J. M. (1986). Audition II: Loudness, pitch, localization, aural distortion, pathology. In K. R. Boff,

- L. Kaufman, & J. P. Thomas (Eds.), *Handbook of perception and human performance: Vol. 1. Sensory processes and perception*. New York: Wiley.
6. Stevens, S. S. (1975). *Psychophysics*. New York: Wiley.

Cross References

- 2.103 Measurement of sound amplitude;
- 2.601 Factors influencing loudness;
- 2.602 Effect of sound pressure level on loudness

Notes

2.604 Effect of Bandwidth on the Loudness of Two-Tone Complexes

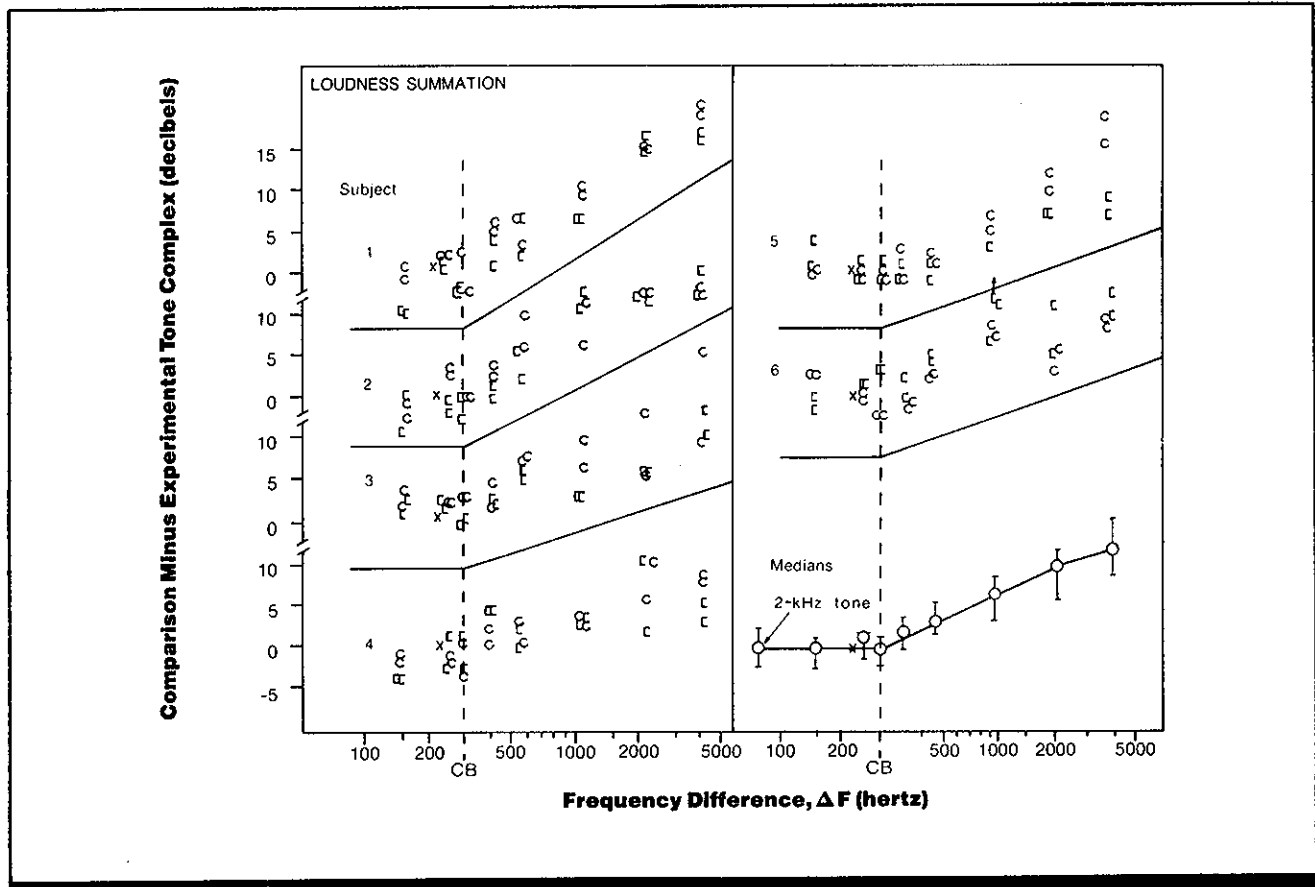

Figure 1. Loudness of a two-tone test complex with center frequency of 2000 Hz, as a function of frequency separation (ΔF) of the components. The vertical axis shows the difference in intensity between a comparison two-tone complex with a component frequency separation of 220 Hz (indicated by the X) and the test (experimental) complex with the frequency separation shown on the horizontal axis, at which the two complexes appeared equally loud. The symbols indicate which sound was adjusted to make the loudness match, the comparison complex (C) or the test complex (I). The dotted line labeled CB indicates the critical band: for frequency separations below this value, two-tone complexes sound equally loud regardless of the frequencies of the components; for frequency separations above this value, the loudness of the complex grows as the frequency separation of the components increases. Data are shown for 6 subjects; medians across subjects are presented in the bottom right panel. Data for a 2000 Hz pure tone are shown for comparison. (From Ref. 2)

Key Terms

Auditory critical band; bandwidth; complex sound; loudness summation; sound intensity

General Description

The loudness of a complex sound remains constant as the frequency separation of its components increases from 0 Hz to a **critical bandwidth**. Beyond this critical bandwidth, loudness increases with frequency separation. For a two-tone complex with a center frequency of 2000 Hz, the criti-

cal bandwidth is ~ 300 Hz. Below this value, the loudness of the complex is invariant at any given intensity, regardless of the frequency separation of the components. For frequency separations > 300 Hz, the loudness of the complex increases as the frequency separation between the components increases.

Methods

Test Conditions

• 53-dB test multitone complex composed of two sinusoidal tones varying in frequency separation but having a geometric mean frequency of 2000 Hz, and a second compari-

son multitone complex having frequency separation fixed at 220 Hz

- Subject seated in anechoic chamber

Experimental Procedure

- Method of adjustment under subject's control

- Independent variable: frequency separation of the tones comprising test multitone complex
- Dependent variable: loudness summation, defined as the difference in intensity (in dB) of the comparison and test multitones when perceived as equally loud

- Subject's task: adjust either comparison multitone to match the test multitone in loudness (one-half of trials) or vice versa
- 4 loudness judgments per frequency separation
- 6 subjects

Experimental Results

- When the separation between components of a two-tone complex is 300 Hz or less, the loudness of the complex remains invariant, regardless of frequency separation (the difference in loudness between a comparison multitone with frequency separation of 220 Hz and the test multitone is ~0 dB).
- At frequency separations above the critical bandwidth of 300 Hz, loudness of a two-tone complex increases as frequency separation of the tones increases (the comparison multitone must be more intense than the test multitone as the frequency separation of the latter increases for the comparison to sound as loud as the test multitone).

Variability

Small between-subject variation was seen in the critical bandwidth and in amount of loudness increase with frequency separation beyond the critical bandwidth. Bars in figure indicate interquartile ranges for medians across subjects.

Repeatability/Comparison with Other Studies

The finding of a critical bandwidth within which loudness of a sound remains constant regardless of the frequencies of its components is the general rule of loudness summation and applies to both line spectra (regardless of the number of components) and continuous spectra.

Constraints

- The width of the critical band varies with center frequency, ranging from ~100 Hz, below a center frequency of 600 Hz, to 4000 Hz at a center frequency of 15,000 Hz.
- The results may not be valid for narrow-band noise at high frequencies and moderate sound levels, where amplitude fluctuations appear to enhance the loudness of subcritical bands of noise (Ref. 4).

- The effect of bandwidth on loudness may vary with intensity level (CRef. 2.606).
- Many factors influence judged loudness and must be considered in applying these results under different conditions (CRef. 2.601).
- There are individual differences in judged loudness.

Key References

1. Marks, L. E. (1979). Sensory and cognitive factors in judgments of loudness. *Journal of Experimental Psychology: Human Perception and Performance*, 5, 426-443.

*2. Scharf, B. (1970). Critical bands. In J. V. Tobias (Ed.), *Foundations of modern auditory theory (Vol. 1)*. New York: Academic Press.

3. Scharf, B., & Houtsma, A. (1986). *Audition II: Loudness*,

pitch, localization, aural distortion, pathology. In K. R. Boff, L. Kaufman, & J. P. Thomas (Eds.), *Handbook of perception and human performance: Vol. 1. Sensory processes and perception*. New York: Wiley.

4. Zwicker, E. (1977). Procedure for calculating loudness of temporally variable sounds. *Journal of the Acoustical Society of America*, 62, 675-682.

Cross References

2.102 Physical parameters and spectral analysis of sound;

2.601 Factors influencing loudness;

2.605 Effect of bandwidth on the loudness of broad-band and moderate-band noise;

2.606 Effect of bandwidth and intensity level on the loudness of continuous noise

2.605 Effect of Bandwidth on the Loudness of Broadband and Moderate-Band Noise

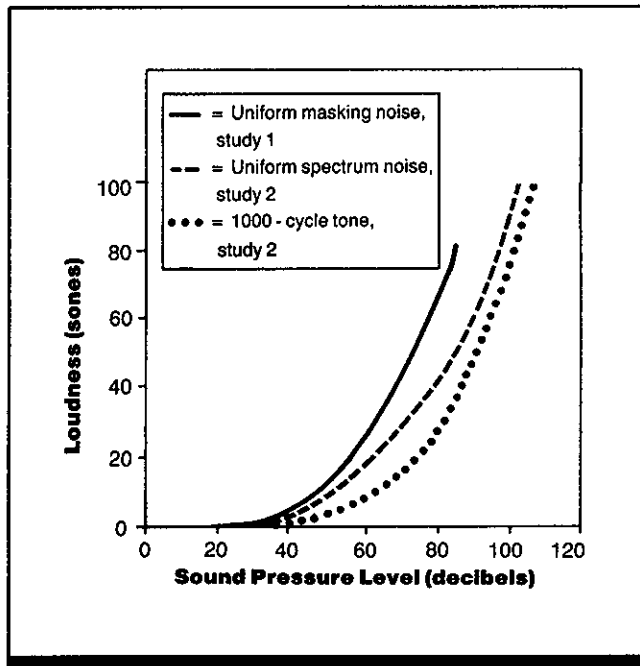

Figure 1. Loudness of three types of sound as a function of intensity. (From Ref. 2)

Key Terms

Auditory masking; bandwidth; noise spectrum; sound intensity; white noise

General Description

The growth of loudness of complex sounds with increasing intensity depends on the bandwidth of the stimulus. Loudness increases most rapidly when the stimulus is a uniform

masking noise, with wide separation of component frequencies, and least rapidly for pure tones. Growth of loudness is intermediate for a uniform-spectrum noise containing moderate frequency dispersion.

Methods

Test Conditions

Study 1 (Ref. 1)

- Amplified wide-band white noise passed through appropriate networks so that its masking effect was nearly constant between 200 and 10,000 Hz
- Noise intensity variations produced by altering amplifier circuit attenuation; noise intensity was 34, 49, 64, 79 or 89 dB re 10^{-16} W/cm²
- Noise presented binaurally via earphones
- Pure tones of various frequencies presented simultaneously with

noise; data presented here only for 1000-Hz tone

Study 2 (Ref. 3)

- Test stimulus was either 1000-Hz tone or white noise with uniform spectrum
- Reference stimulus and test stimulus presented alternately for 2 sec each between 60 and 5700 Hz; reference stimulus varied, depending on procedure used
- Stimuli presented via earphones
- Subjects tested in soundproof room

Experimental Procedures

Study 1

- Method of constant stimuli

- Independent variable: intensity of noise stimulus
- Dependent variable: loudness level of noise stimulus, measured as amount by which threshold for 1000-Hz tone raised in presence of noise of a given intensity
- Subject's task: indicate whether tone detected in presence of masking noise
- 28 subjects

Study 2

- Method of adjustment under subject's control
- Independent variable: intensity of test stimulus
- Dependent variable: loudness of test stimulus
- Subject's task: three sound-com-

parison procedures used: (a) subject adjusted intensity of test stimulus to sound half or twice as loud as reference stimulus of given intensity; both stimuli presented monaurally; (b) following adjustment to compensate for differences in sensitivity of the two ears, subject adjusted intensity of a test stimulus presented binaurally to match the loudness of the same stimulus presented monaurally; (c) subject adjusted intensity of monaural 1000-Hz tone to sound equally loud as a monaural noise stimulus (yielding scale of loudness for noise by comparison with standard loudness scale for 1000-Hz tone)

- 7 subjects

Experimental Results

- As physical intensity increases, loudness increases most rapidly for uniform masking noise, less rapidly for uniform-spectrum noise, and least rapidly for a 1000-Hz tone.

Variability

In Study 1, the standard deviation of each observation was ~9 dB. There was fair agreement in the results obtained by the various methods in Study 2.

Repeatability/Comparison with Other Studies

Several studies have shown that perceived loudness of complex tones depends on the frequency dispersion of component tones. For complex tones with a sufficiently large frequency separation, total loudness equals the sum of the loudnesses of the components; however, when the frequency separation is below some critical value, total loudness is less than the loudness sum of the components (CRef. 2.604).

Constraints

- Variability was very large for results with uniform matching noise.
- Results may not be valid for very weak signals or for very intense signals.

- Many factors influence judged loudness and must be considered in applying these results under different conditions (CRef. 2.601).
- There are individual differences in judged loudness.

Key References

*1. Fletcher, H., & Munson, W. A. (1937). Relation between loudness and masking. *Journal of the Acoustical Society of America*, 9, 1-10.

2. Licklider, J. C. R. (1951). Basic correlates of the auditory stimulus. In S. S. Stevens (Ed.), *Handbook of experimental psychology* (pp. 985-1039). New York: Wiley.

*3. Pollack, I. (1948). *Studies in the loudness of complex sounds*. Unpublished doctoral dissertation, Harvard University, Cambridge, MA.

Cross References

2.102 Physical parameters and spectral analysis of sound;

2.601 Factors influencing loudness;
2.604 Effect of bandwidth on the loudness of two-tone complexes;

2.606 Effect of bandwidth and intensity level on the loudness of continuous noise;
Handbook of perception and human performance, Ch. 15, Sect. 1.2

2.606 Effect of Bandwidth and Intensity Level on the Loudness of Continuous Noise

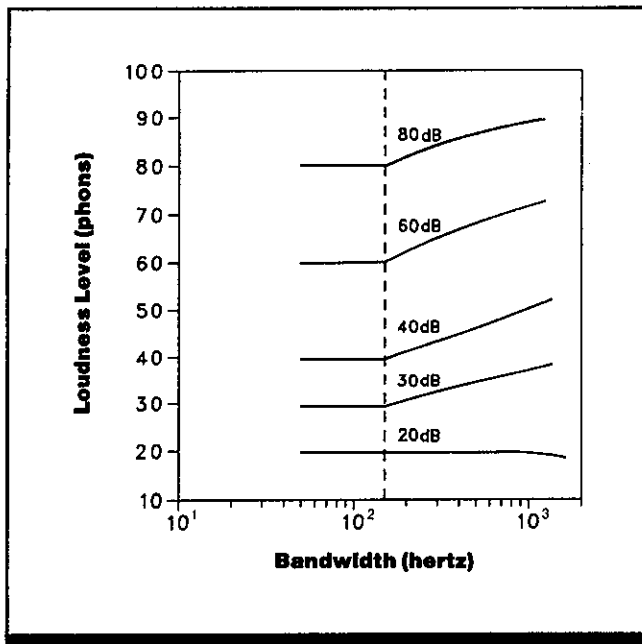

Figure 1. Loudness level of a band of continuous noise centered on 1000 Hz as a function of noise bandwidth (where loudness level is the loudness of the noise in relation to a 1000-Hz reference tone). The overall sound pressure level of the noise (in decibels) is shown on each curve. The vertical dashed line indicates the critical bandwidth. (From Ref. 2)

Key Terms

Auditory critical band; bandwidth; complex sound; loudness summation; noise; sound intensity

General Description

The loudness of continuous noise varies with both the bandwidth and the intensity (sound pressure level) of the noise. At low intensities, loudness is independent of bandwidth (i.e., for a given intensity level, loudness is constant re-

gardless of the bandwidth of the noise). At higher intensity levels, however, loudness is independent of bandwidth only up to a **critical bandwidth**; beyond this critical bandwidth, loudness of the noise increases as bandwidth increases.

Applications

Presentation of broadband auditory signals.

Methods

Test Conditions

- Band of continuous noise centered at 1000 Hz alternated with 1000-Hz reference tone; duration of each was ~600 msec

- Overall intensity of noise band held constant at 20, 30, 40, 60 or 80 dB SPL; bandwidth of noise varied

Experimental Procedure

- Tracking procedure

- Independent variables: bandwidth of noise, overall intensity of noise
- Dependent variable: loudness level of noise, measured as the intensity level of a 1000-Hz reference tone that appears equal in loudness to the noise

- Subject's task: increase level of reference tone until it sounds louder than noise, then decrease level of reference tone until it sounds softer
- Number of subjects not reported

Experimental Results

- The loudness of continuous noise with center frequency of 1000 Hz at an intensity of 20 dB SPL is relatively constant, regardless of the bandwidth of the noise.
- For noise levels >20 dB SPL, loudness is constant only up to a critical bandwidth of ~160 Hz, beyond which loudness of the noise increases with bandwidth.
- Similar dependence of loudness on bandwidth was found to hold for noise with other center frequencies and for multitone complexes.

Variability

No information on variability was given. However, in a later study (Ref. 3) producing essentially the same results, interquartile ranges were 1-8 dB, depending on how similar reference and test signals appeared.

Repeatability/Comparison with Other Studies

Reference 3 reports similar results.

Constraints

- Results may not be valid for stimuli of greater intensities than those used in the present study.
- Many factors influence judged loudness and must be considered in applying these results under different conditions (CRef. 2.601).
- There are individual differences in judged loudness.

Key References

- | | | |
|---|---|---|
| <p>1. Scharf, B., & Houtsma, A. (1986). Audition II: Loudness, pitch, localization, aural distortion,</p> | <p>pathology. In K. R. Boff, L. Kaufman, & J. P. Thomas (Eds.), <i>Handbook of perception and human performance: Vol. 1. Sensory processes and perception</i>. New York: Wiley.</p> | <p>3. Zwicker, E., Flottorp, G., & Stevens, S. S. (1957). Critical bandwidth in loudness summation. <i>Journal of the Acoustical Society of America</i>, 29, 548-557.</p> |
| <p>2.601 Factors influencing loudness;</p> | <p>*2. Zwicker, E., & Feldtkeller, R. (1955). Über die Lautstärke von gleichförmigen Geräuschen. <i>Acustica</i>, 5, 303-316.</p> | |

Cross References

- 2.601 Factors influencing loudness;
- 2.604 Effect of bandwidth on the loudness of two-tone complexes;
- 2.605 Effect of bandwidth on the loudness of broadband and moderate-band noise

2.607 Effect of Duration on the Loudness of Narrow-Band Noise

Key Terms

Narrow-band noise; sound intensity; temporal summation

General Description

For stimulus durations up to ~70-100 msec, the loudness of narrow-band noise depends on sound energy (intensity \times duration). That is, as duration increases, the stimulus intensity (sound pressure) required to maintain constant loudness decreases in direct proportion. Above this critical duration, loudness is independent of the duration of the sound and depends only on intensity.

Applications

Control of loudness of auditory signals.

Methods

Test Conditions

- Stimuli were narrow-band noise of constant 1200 msec duration and narrow-band noise of variable (short) duration, both centered on 2500 Hz; for first set of measurements, intensity of constant, long-duration noise set at 60 dB SPL
- Sounds presented via loud-speaker in anechoic room

Experimental Procedure

- Tracking method

- Independent variable: noise duration
- Dependent variable: median sound pressure level at which noise of given duration sounds as loud as noise of 1200 msec duration
- Subject's task: subject adjusted intensity of short duration noise to match loudness of constant, long-duration noise set at 60 dB SPL; then in later measurements subject set intensity of long-duration noise to match the previously adjusted level of the short-duration noise
- 8 subjects

Experimental Results

- Up to a critical duration of ~70 msec duration, loudness of a noise stimulus depends on integrated sound energy (intensity \times duration).
- For durations greater than ~70 msec, loudness does not change with duration but depends only on sound pressure level.
- In Figure 1, a straight line has been drawn through the data to represent constant sound energy up to 70 msec. Data could be somewhat better fit by an exponential function of the form

$$I(t) = \frac{I_{\infty}}{1 - e^{-t/\tau}} \quad (1)$$

Constraints

- Many factors influence judged loudness (CRef. 2.601). The effects of some variables may be seen in Table 1.
- There are individual differences in judged loudness. Vari-

Key References

1. Békésy, G. von. (1929). Zur Theorie des Hörens: Über die Bestimmung des einem reinen tonempfindend entsprechenden Erregungsgebietes der Basilarmembran vermittelt Ermüdungsserscheinungen. *Physikalische Zeitschrift*, 30, 115-125.
2. Boone, M. M. (1973). Loudness measurements on pure tone and broadband impulsive sounds. *Acustica*, 29, 198-204.
3. Ekman, G., Berglund, B., & Berglund, U. (1966). Loudness as a function of the duration of auditory stimulation. *Scandinavian Journal of Psychology*, 7, 201-208.
4. Gardner, W. R. (1949). The loudness and loudness matching of short tones. *Journal of the Acoustical Society of America*, 21, 398-401.

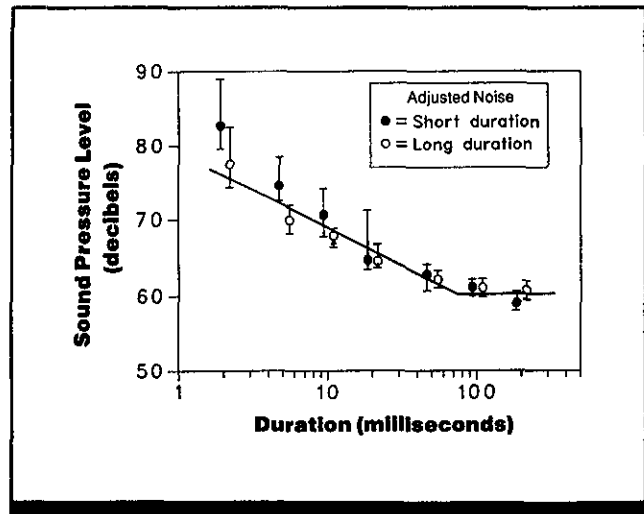

Figure 1. Loudness as a function of duration for narrow-band noise centered on 2500 Hz. The vertical axis shows the sound pressure level at which a short-duration noise stimulus of the duration given on the horizontal axis sounds as loud as a noise of long (1200 msec) duration. Subject adjusted either the short-duration noise (filled circles) or long-duration noise (open symbols) to match loudness. The straight line drawn through the data represents constant sound energy up to a duration of 70 msec, after which level is constant. (From Ref. 11)

where $I(t)$ is the sound intensity required to maintain constant loudness, I_{∞} is the asymptotic intensity at long duration, t is stimulus duration, and τ is the time constant.

Variability

Interquartile ranges are shown in Fig. 1.

Repeatability/Comparisons with Other Studies

Table 1 summarizes a number of related experiments. While there is great heterogeneity in the results, it generally appears that, up to ~100 msec, loudness increases with duration and energy (intensity \times duration) is roughly constant for constant loudness.

ability in the data of Table 1 is probably due mainly to differences in the criteria adopted by different listeners in judging the loudness of brief stimuli.

5. Miller, G. A. (1948). The perception of short bursts of noise. *Journal of the Acoustical Society of America*, 20, 160-170.
6. Munson, W. A. (1947). The growth of auditory sensation. *Journal of the Acoustical Society of America*, 19, 584-591.

7. Niese, H. (1956). Vorschlag für die Definition und Messung der Deutlichkeit nach subjectiven Grundlagen. *Hochfrequenztechnik und Elektroakustik*, 65, 4-15.
8. Niese, H. (1959). Die Trägheit der Lautstärkebildung in Abhängigkeit vom Schallpegel. *Hochfrequenztechnik und Elektroakustik*, 68, 143-152.

Table 1. Dependence of the loudness of brief tones and noises on duration. (From Ref. 13)

References	Number Subjects	Stimulus	Rise-Fall Time (msec)	Trading Relation ^b	Critical Duration ^c (msec)	Time Constant ^d (msec)	Effect of Intensity Level
Ref. 5	3	White noise	Abrupt	Energy increases	60-140	—	Critical duration decreases as level increases
Ref. 10	7-10	White noise	Abrupt	Energy constant	100	—	—
Ref. 15	12	White noise	—	Energy decreases	15-50	—	Constant duration decreases as level increases
Ref. 17	12	White noise	—	Energy decreases	150	—	None
Ref. 18	83	White noise	Abrupt	Energy constant	120-400	100	—
	74	1,000 Hz	1-2	Energy constant	200-400	100	—
Ref. 1	—	800 Hz	Abrupt	Energy increases	120-180	—	Critical duration shorter at higher levels
Ref. 2	14-20	500, 1,000, 4,000 Hz	5	Energy constant	150	120	—
Ref. 3	10	1,000 Hz	10	Energy increases	Over 500	—	Steeper trading relation at high levels
Ref. 4	6	1,000 Hz	Abrupt	Energy increases	500	—	Steeper trading relation at higher levels
Ref. 6	—	125, 1,000, 5,650 Hz	3	Energy decreases	200	—	Steeper trading relation at higher levels
Ref. 7	12	500, 1,000, 3,000 Hz	Abrupt	Energy constant	65	23	—
Ref. 8	10	1,000 Hz	1-2	Energy increases	100	23	None
Ref. 9	381	1,000 Hz	1-2	Energy constant or decreases	160-320	80	Steeper trading relation at lower levels
Ref. 12	50	1,000 Hz	3	Energy constant	100	30	—
		250 Hz			100		
Ref. 16	10	1,000			90		
		4,000	Abrupt	Energy constant	10	—	—
Ref. 11 ^a	8	Narrow-band noise at 350, 2,000, 10,000 Hz	1-2	Energy constant	70	70	None

NOTE: A dash means the information either was not relevant to the study or was not provided.

^aDespite much heterogeneity in the results, the overall picture is that loudness increases with duration up to about 100 msec.

At durations shorter than 100 msec, energy (intensity X duration) is approximately constant for constant loudness.

^bTrading relation refers to the relation between intensity and time. As stimulus duration increases up to the critical duration, to keep loudness constant, total sound energy ($I \times t$) has been found to remain constant, decrease, or increase.

^cFor constant loudness, intensity must be reduced as duration is increased up to the critical duration.

^dThe time constant was calculated from an exponential function of the form given in Eq. 1.

9. Pedersen, O. J., Lyregaard, P. E., & Poulsen, T. E. (1977). *The round robin test on evaluation of loudness level of impulsive noise* (Report No. 22). Copenhagen: Technical University of Denmark, Acoustics Laboratory.

10. Pollack, I. (1958). Loudness of periodically interrupted white noise. *Journal of the Acoustical Society of America*, 30, 181-185.

11. Port, E. (1963). Über die Lautstärke einzelner Kurzer Schallimpulse. *Acustica*, 13, 212-223.

12. Reichardt, W., & Niese, H. (1970). Choice of sound duration and silent intervals for test and comparison signals in the subjective measurement of loudness level. *Journal of the Acoustical Society of America*, 47, 1083-1090.

13. Scharf, B. (1978). Loudness. In E. C. Carterette and M. P. Friedman (Eds.), *Handbook of perception Vol. IV: Hearing* (pp. 187-242). New York: Academic Press.

14. Scharf, B., & Houtsma, A. (1986). Audition II: Loudness, pitch, localization, aural distortion, pathology. In K. R. Boff, L. Kaufman, & J. P. Thomas (Eds.), *Handbook of perception and human performance: Vol. 1. Sensory processes and perception*. New York: Wiley.

15. Small, A. M., Jr., Brandt, J. F., & Cox, P. G. (1962). Loudness as a function of signal duration. *Journal of the Acoustical Society of America*, 34, 513-514.

16. Stephens, S. D. G. (1974). Methodological factors influencing loudness of short duration sounds. *Journal of Sound and Vibration*, 37, 235-246.

17. Stevens, J. C., & Hall, J. W. (1966). Brightness and loudness as functions of stimulus duration. *Perception & Psychophysics*, 1, 319-327.

18. Zwicker, E. (1966). Ein Beitrag zur Lautstärkemessung impulsaltiger Schalle. *Acustica*, 17, 11-22.

Cross References

2.601 Factors influencing loudness

2.608 Monaural Versus Binaural Loudness

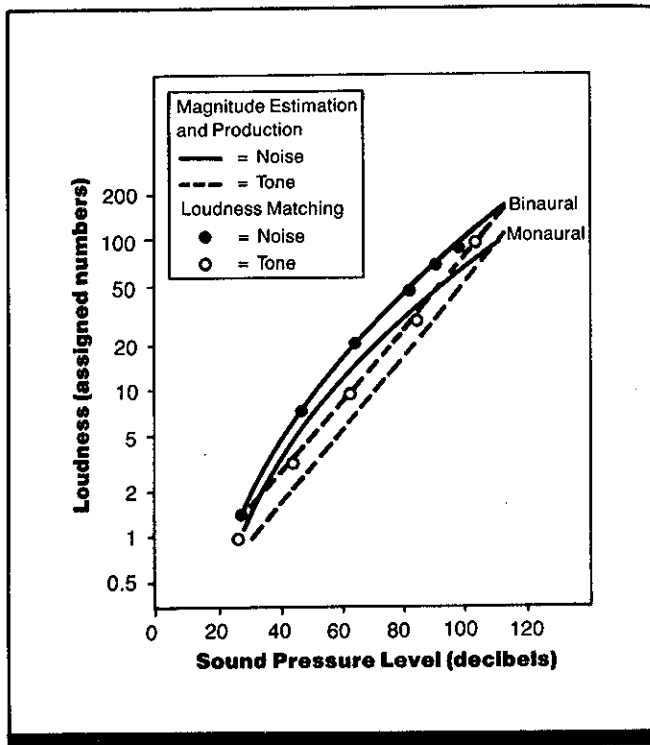

Figure 1. Loudness of monaural and binaural tones and noise. Curves for tone and noise stimuli are averages of the curves obtained using the magnitude estimation and magnitude production procedures. Dashed lines for tone stimuli are based on least-squares fit of a power function to the data obtained using each procedure; curves for noise stimuli are derived from visual fits to the data. For comparison, the circles show data for tones and noise obtained from a matching experiment (Ref. 2) in which subjects matched binaural and monaural signals for loudness. (From Ref. 4)

Key Terms

Binaural loudness; loudness summation; monaural loudness; sound intensity; white noise

General Description

A sound presented to both ears may be judged almost twice as loud as the same sound presented to only one ear. For both binaural and monaural tones, loudness grows as a

power function of intensity. The loudness of binaural or monaural noise is not a power function of intensity but grows more rapidly with intensity at low sound pressure levels and more slowly at high sound pressure levels.

Methods

Test Conditions

- Subjects sat in sound-treated booth
- **White noise** or 1000-Hz tone presented **monaurally** or **binaurally** (same sound to both ears) through earphones

Experimental Procedure

- Magnitude estimation: magnitude production
- Independent variables: presentation mode (monaural versus binaural), sound pressure level (SPL)

- Dependent variable: in magnitude estimation relative loudness of sound of given SPL; in magnitude production, SPL corresponding to specified relative loudness
- Subject's task: in magnitude estimation, estimate loudness by assigning a number to sound; in magnitude production, adjust loudness of sound to match number give by experimenter
- 15 subjects (8 men and 7 women), all but 2 under age 26; all but 1 had thresholds within 20 dB of normal 400 and 6,000 Hz; mean threshold difference between the two ears was 4.1 dB at 1000 Hz; no subject had a difference >9 dB

Experimental Results

- The ratio of binaural to monaural loudness is between 1.6 and 1.85 over an intensity range of 40-110 dB sound pressure level (SPL).
- For tones, loudness is a power function of the SPL of the tone; i.e., $L = kP^n$, where L is loudness, P is SPL, and k is a constant of proportionality that depends on the unit of measurement; n is 0.50 for the monaural tone and 0.48 for the binaural tone and is the slope of the line in Fig. 1.
- The data for noise stimuli do not obey the power law (data do not fall along a straight line on log-log coordinates); the loudness of white noise increases more rapidly at level <50 dB SPL than at higher levels.
- The loudness of binaural noise increases more rapidly with SPL than does the loudness of monaural noise.

Variability

Interquartile ranges generally increased as the SPL increased, with ranges of 1-60 assigned numbers for magnitude estimation and 5-15 dB for magnitude production.

Repeatability/Comparison with Other Studies

Binaural-to-monaural loudness ratios for tones are comparable to those found in other studies. Ref. 1 found binaural-to-monaural ratios for noise stimuli that were larger and grew more rapidly with SPL. Binaural tone stimuli are louder than monaural stimuli regardless of whether the binaural stimuli are diotic (same tone frequency to each ear) or dichotic (different frequency to each ear) (Ref. 3).

Constraints

- Many factors influence loudness and must be considered in applying these results under different conditions (CRef. 2.601).
- There are individual differences in judged loudness.

Key References

1. Reynolds, G. S., & Stevens, S. S. (1960). Binaural summation of loudness. *Journal of the Acoustical Society of America*, 32, 1337-1344.

2. Scharf, B. (1968). Binaural loudness summation as a function of bandwidth. *Reports of the Sixth International Congress on Acoustics. Tokyo, 1968* (Paper A-3-5, pp. 2528). New York: American Elsevier.

3. Scharf, B. (1969). Dichotic summation of loudness. *Journal of the Acoustical Society of America*, 45, 1193-1205.

*4. Scharf, B., & Fishken, D. (1970). Binaural summation of loudness: Reconsidered. *Journal*

of Experimental Psychology, 86, 374-379.

5. Békésy, G. von (1960). *Experiments in hearing*. New York: McGraw-Hill.

Cross References

2.601 Factors influencing loudness

2.609 Effect of Interaural Phase on the Loudness of Masked Tones

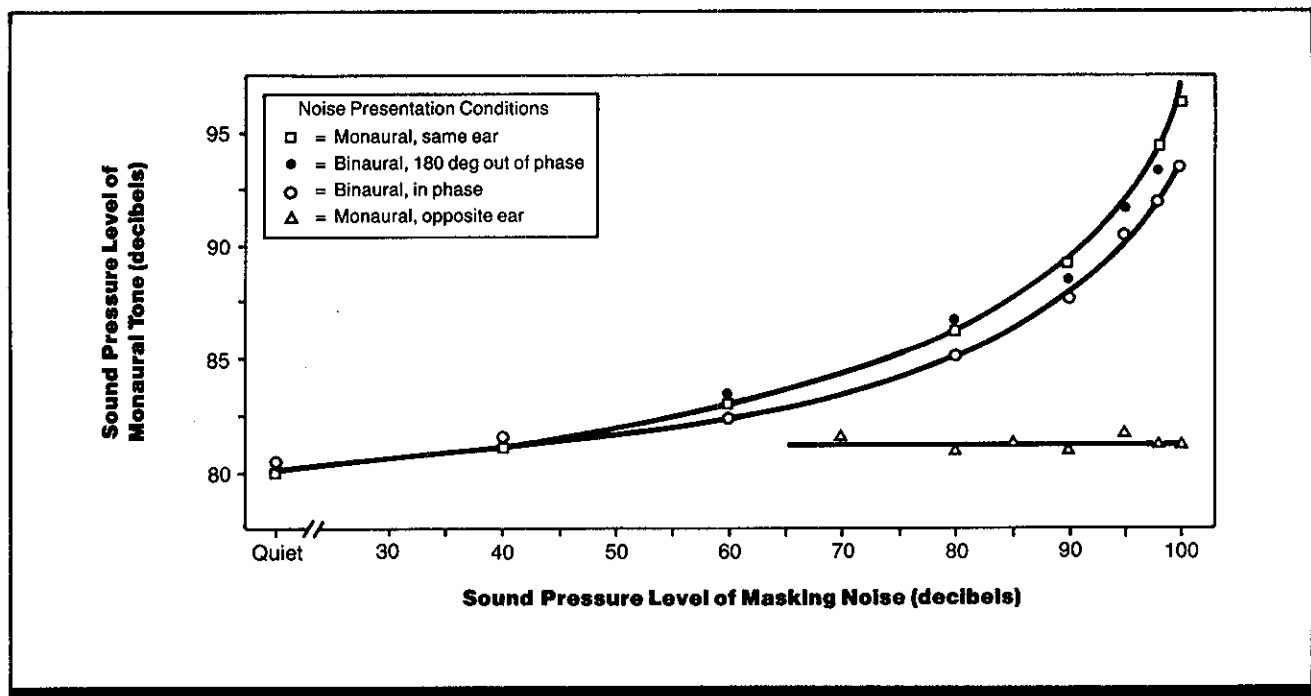

Figure 1. Sound pressure level of a 250-Hz monaural tone presented in noise that sounds equal in loudness to a 250-Hz 80-dB monaural tone presented in quiet (Study 1). Each data point represents the mean of eight judgments, two by each of 4 subjects. (From Ref. 1)

Key Terms

Interaural phase differences; noise masking; sound intensity

General Description

Interaural phase angle affects loudness judgments under conditions in which a subject is required to separate an auditory signal from background noise. The effect is observed at signal-to-noise ratios near the masked threshold; at higher signal-to-noise ratios that approach listening in quiet, no effect of interaural phase on loudness is observed.

Applications

Discrimination of signals in a noisy environment.

Methods

Test Conditions

Study 1 (Ref. 1)

- Variable intensity 250-Hz tone presented **monaurally**; background of white noise presented (a) monaurally to same ear as tone, (b) monaurally to opposite ear from tone, (c) **binaurally** in phase, or (d) binaurally 180 deg out of phase
- 80-dB sound pressure level (SPL) 250-Hz reference tone presented monaurally in quiet

- Earphone presentation

Study 2 (Ref. 1)

- Variable intensity, binaural 250-Hz tone presented in background of binaural white noise
- Tone presented to the two ears either in-phase (homophasic condition) or 180 deg out-of-phase (antiphasic condition); background noise in-phase in all conditions
- 80-dB SPL 250-Hz reference tone presented monaurally in quiet
- Earphone presentation

Experimental Procedure

Study 1

- Independent variables: mode of presentation of masking noise, intensity of masking noise
- Dependent variable: intensity of tone presented in noise that was judged equal in loudness to 80-dB tone presented in quiet
- Subject's task: match loudness of tone presented in noise background with reference tone presented in quiet
- 4 subjects

Study 2

- Independent variables: mode of presentation of tone, intensity of masking noise
- Dependent variable: intensity of tone presented in noise that was judged equal in loudness to 80-dB tone presented in quiet
- Subject's task: match loudness of tone presented in noise background with reference tone presented in quiet
- 4 subjects

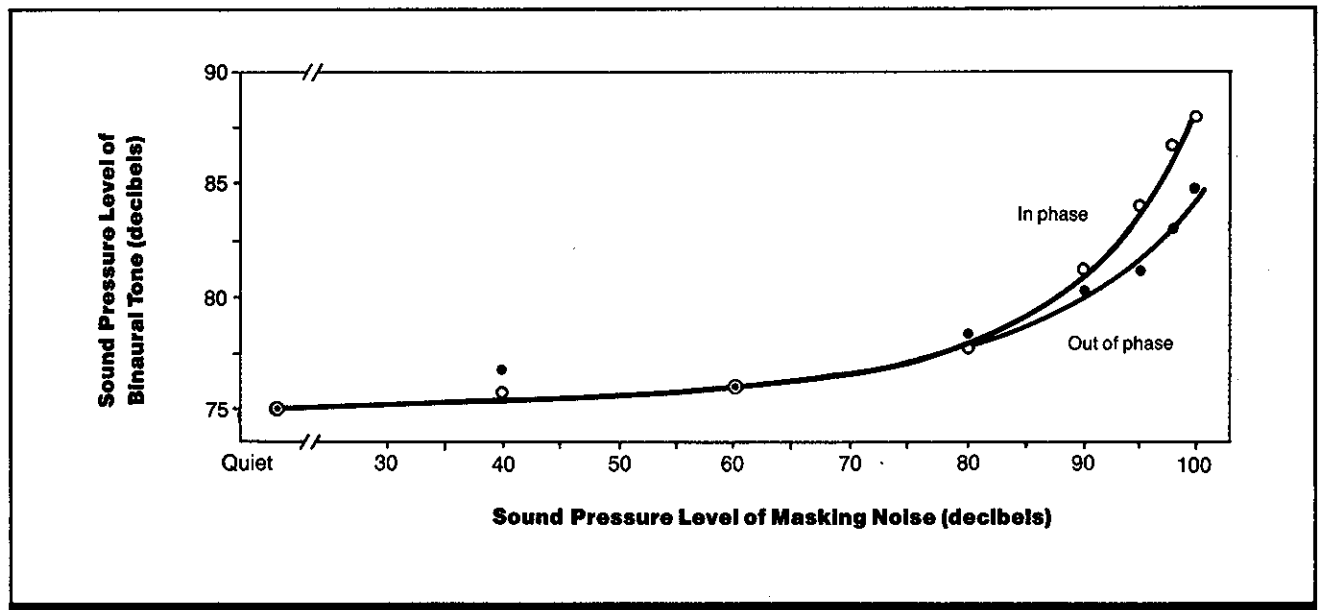

Figure 2. Sound pressure level of 250-Hz tone presented binaurally in noise that sounds equal in loudness to a monaural 250-Hz 80-dB tone presented in quiet (Study 2). Tones were in phase or 180 deg out-of-phase in the two ears as indicated. (From Ref. 1)

Experimental Results

- The loudness of a monaural tone is reduced more by monaural noise presented to the same ear as the tone than by binaural noise (Fig. 1).
- The interaural phase of the noise mask has a clear effect only near the masked threshold for the tone, i.e., when background noise is intense relative to tone intensity (Fig. 1).
- At low signal-to-noise ratios (noise intensity high relative

to tone intensity), the loudness of a binaural tone presented in phase at the two ears shows a greater reduction as noise level increases than does the loudness of a tone presented in antiphase (Fig. 2).

Variability

No information on variability was given.

Repeatability/Comparison with Other Studies

Data are consistent with results of studies on noise masking.

Constraints

- Results may not apply for signals other than pure tones or for intensity and frequency constraints other than those used.

- Many factors influence judged loudness and must be considered in applying these results under different conditions (CRef. 2.601).
- There are individual differences in judged loudness.

Key References

*1. Hirsh, I. J., & Pollack, I. (1948). The role of interaural phase in loudness. *Journal of the Acoustical Society of America*, 20, 761-766.

Cross References

2.306 Factors affecting auditory sensitivity in the presence of masking noise;

2.315 Binaural reduction of masking: effect of interaural phase differences;

2.601 Factors influencing loudness;

8.314 Noise masking of speech: effect of interaural phase relations;

Handbook of perception and human performance, Ch. 15, Sect. 1.

2.610 Loudness of Intermittent Stimuli

Key Terms

Intermittent stimulation; pulse train; temporal summation

General Description

Sounds often are intermittent, occurring as single pulses or as trains of repeated pulses. The following table describes how loudness varies for concurrent single pulses and for repetitive pulses, and cites sources of additional information.

Constraints

- The data may not be valid in the presence of background or masking sounds.
- Many factors influence judged loudness (CRef. 2.601).
- There are individual differences in judged loudness.

Key References

1. Botte, M.-C. (1974). Effet du délai interaural pour des clics binoculaires sur la sonie et sur les réponses évoquées. *Acustica*, 31, 256-265.
2. Elmasian, R., & Galambos, R. (1975). Loudness enhancement:

Monaural, binaural and dichotic. *Journal of the Acoustical Society of America*, 58, 229-234.

3. Irwin, R. J., & Zwislocki, J. J. (1971). Loudness effects in pairs of tone bursts. *Perception & Psychophysics*, 10, 189-192.

4. Niese, H. (1956). Vorschlag für die Definition und Messung der

Deutlichkeit nach subjectiven Grundlagen. *Hochfrequenztechnik und Elektroakustik*, 65, 4-15.

5. Port, E. (1963). Zur Lautstärkeempfindung und Lautstärkemessung von pulsierenden Geräuschen. *Acustica*, 13, 224-233.

6. Scharf, B. (1970). Loudness and frequency selectivity at short dura-

tions. In R. I. Plomp & G. F. Smoorenburg (Eds.), *Frequency analysis and periodicity detection in hearing*. Leiden, The Netherlands: A. W. Sijthoff.

7. Schwarze, D. (1963). *Die Lautstärke von Gausstönen*. Unpublished doctoral dissertation, Technische Universität, Berlin.

Cross References

2.601 Factors influencing loudness;

Handbook of perception and human performance, Ch. 15, Sect. 1.

Table 1. Loudness of Intermittent stimuli.

Type of Stimulus	Loudness	References
Double pulses	<p>The overall loudness level of two equally loud tone bursts, each ~10 msec or less in duration and separated by <2 msec, is 3 phons greater than the level of either pulse alone</p> <p>A loudness increase of 10 phons for double over single pulses has been reported for pulses of very different frequencies</p> <p>As the inter-pulse interval lengthens, the combined loudness level decreases until the two pulses are no louder than either pulse alone</p> <p>The estimated limits of this temporal summation vary from 25-200 msec</p> <p>When a subject judges the loudness of a single tone burst, the loudness level is increased when the pulse is preceded by a more intense pulse if the separation between the two is <500 msec</p> <p>The loudness level of a single tone burst is decreased when it is preceded by a less intense pulse if the separation is >500 msec</p>	<p>Refs. 1, 3, 4, 6, 7</p> <p>Ref. 2</p>
Pulse trains	<p>At repetition rates of 2 pulses/sec or more, a pulse train (series of brief sounds repeated over and over) sounds louder than a continuous sound of equal overall energy (where energy = intensity × duration)</p> <p>At these repetition rates, the pulse train sounds softer than a continuous sound of equal intensity</p> <p>At repetition rates <2 pulses/sec, the pulses are too far apart for temporal summation to occur and the pulse train is less loud than a continuous sound, even when sound energy is equal</p>	<p>Ref. 5</p>

Notes

2.611 Loudness Reduction Under Masking by Broadband Noise and Narrow-Band Noise

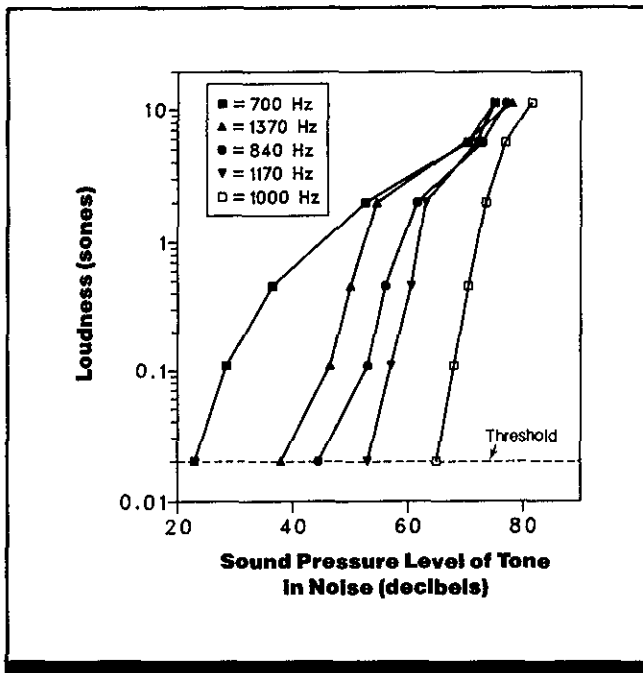

Figure 1. Loudness of pure tones of various frequencies as a function of intensity under masking by narrow-band noise (Study 1). (From Ref. 1)

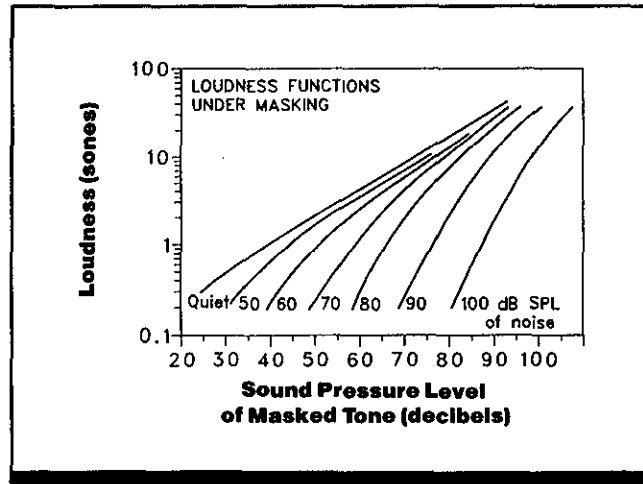

Figure 2. Loudness functions are shown for several different levels of masking noise, as indicated on the curves of a 1000-Hz tone as a function of intensity under masking by broadband (white) noise (Study 2). (From Ref. 2, based on data from Ref. 4)

Key Terms

Broadband noise; loudness reduction; narrow-band noise; noise masking; partial masking; sound intensity; white noise

General Description

Partial masking is the reduction of the loudness of a tone, caused by a background noise. For narrow-band noise, masking is greater (loudness is reduced) for tones that fall within the frequency range of the noise; at a given level of intensity, the further removed the frequency of the tone from the frequency of the noise, the less masking and the greater the loudness of the tone. Tones at frequencies above those of the masking noise have higher masked thresholds than tones equally distant below the noise, but increase in

loudness so rapidly that they reach or exceed the loudness of lower-frequency tones at higher intensity levels. As the level of the background broadband (white) noise increases, the loudness of the signal increases more rapidly as sound pressure level (SPL) increases (i.e., the loudness function steepens). When the noise background is less than ~80 dB SPL and the signal is 20-30 dB above its masked threshold, the signal appears as loud in the noise as in the quiet. With more intense background noise, loudness does not reach its full unmasked value.

Applications

Discrimination of signals in noisy environments.

Methods**Test Conditions****Study 1 (Ref. 1)**

- Pure tones of 700-1370 Hz presented alternately in quiet or in the presence of 70 -dB SPL masking noise centered on 1000 Hz and 160 Hz wide
- Masking noise presented for 1500 msec; pure tone came on for 700 msec starting 500 msec after onset of masking noise
- Loudness level of pure tones varied from 15-75 phons
- Rise/fall time of both tone and masker was 50 msec
- 50-dB low-pass noise used to mask equipment sounds; reportedly this did not affect the signal

- Stimuli presented binaurally through earphones

Study 2 (Ref. 4)

- 1000-Hz tone presented alternately in quiet and in wide-band noise (75-9600 Hz)
- Background noise was turned on 400 msec before tone and turned off 500 msec after tone; tone durations were 1.9 sec in noise and 1.8 sec in quiet
- Intertone interval ~1 sec
- Stimuli presented through earphones

Experimental Procedure**Study 1**

- Method of adjustment

- Independent variables: intensity of (reference) tone in quiet, frequency of test tone
- Dependent variable: amount of masking, measured as the median difference in the intensity of the tone in noise and the intensity of the same tone in quiet when the two appeared equally loud; masking level converted to loudness (in sones) for plotting here
- Subject's task: for threshold judgments, adjust the intensity of the pure tone to the point where it just becomes audible or just becomes inaudible; for loudness judgments, adjust tone in presence of

- noise to sound as loud as in quiet
- 4 subjects

Study 2

- Method of adjustment
- Independent variables: intensity of tone in noise, intensity of background noise
- Dependent variable: SPL at which tone in quiet was judged equally loud as the tone in noise
- Subject's task: adjust tone in quiet to match loudness of tone in noise
- Complete data for all levels of masking noise were obtained for 2 subjects; data for mid-range masking noises were obtained from 9 subjects

Experimental Results

- The loudness of tones presented in the presence of narrow-band masking noise depends on the frequency relation between the tone and the noise. Tones at frequencies more widely removed from the noise band are louder at a given intensity than tones whose frequencies are close to the frequency limits of the noise. Tones located within the frequency confines of noise are least loud.
- Tones at frequencies above those of the masking noise have higher thresholds in the presence of the noise than tones equally far below the noise.
- As intensity rises, tones at frequencies above the noise increase in loudness more rapidly than tones below the noise; the increase in loudness for the higher-frequency tones is so rapid that at higher intensity levels their loudness may equal or exceed that of lower-frequency tones.

- How rapidly the loudness of a masked tone increases as the intensity of the tone increases depends on the level of the masking noise. For wide-band masking noise, the greater the intensity of the noise, the more elevated the threshold for the tone and the steeper its loudness function (i.e., the more rapidly loudness grows with intensity).
- With background noise less than ~80 dB SPL, the tone appears as loud in the noise as in quiet once the tone is 20-30 dB above its masked threshold; with more intense background noise, the loudness of the tone does not seem to reach its full unmasked value.

Variability

No information on variability was given.

Repeatability/Comparison with Other Studies

Similar data have been reported in other studies.

Constraints

- The data may not be valid for other types of signal/mask combinations, e.g., with noise as the signal and a pure tone as the mask.

- The extent of partial masking depends on the frequency relation between mask and signal.
- Many factors influence judged loudness and the audibility of a masked tone and must be considered in applying these results under different conditions (CRefs. 2.306, 2.601).
- There are individual differences in judged loudness.

Key References

*1. Scharf, B. (1971). Patterns of partial masking. *Proceedings of the Seventh International Congress on Acoustics*, Budapest.

2. Scharf, B. (1978). Loudness. In E. C. Carterette & M. P. Friedman (Eds.), *Handbook of perception*. Vol. IV (pp. 187-242). New York: Academic Press.

3. Scharf, B., & Houtsmma, A. (1986). Audition II: Loudness,

pitch, localization, aural distortion, pathology. In K. R. Boff, L. Kaufman, & J. P. Thomas (Eds.), *Handbook of perception and human performance*: Vol. 1. Sen-

sory processes and perception. New York: Wiley.

*4. Stevens, J. C., & Guirao, M. (1967). Loudness functions under inhibition. *Perception & Psychophysics*, 2, 459-465.

Cross References

2.306 Factors affecting auditory sensitivity in the presence of masking noise;

2.601 Factors influencing loudness

2.612 Loudness Adaptation

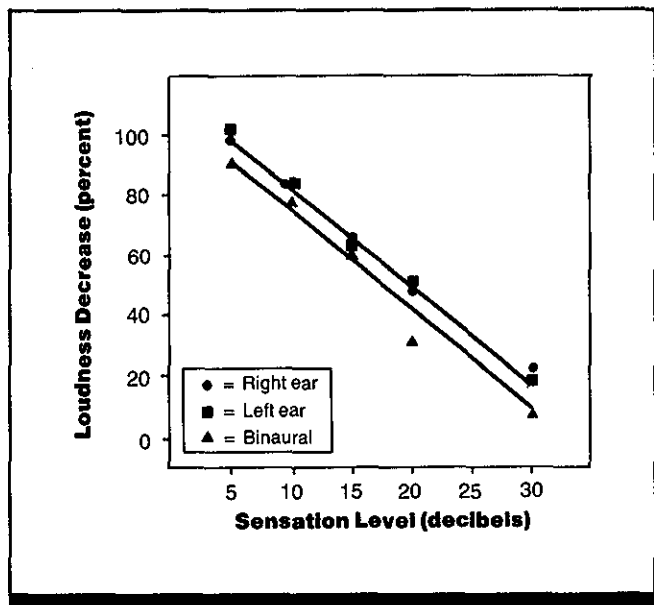

Figure 1. Loudness adaptation (measured as percentage decrease in loudness) as a function of sensation level for a 4000-Hz tone after 2 min of exposure. Tone presented either monaurally (open symbols) or binaurally (filled symbols). Inset shows mean thresholds for each listening condition. (From Ref. 1)

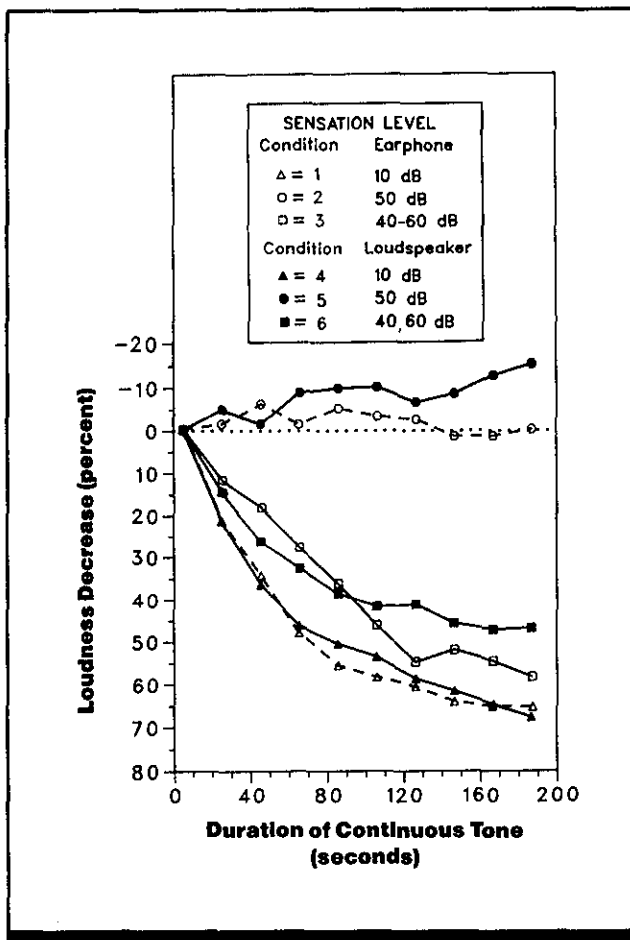

Figure 2. Loudness adaptation (measured as percentage decrease in loudness) for a 1000-Hz tone as a function of stimulus duration under various listening conditions. Tone was on continuously in conditions 1, 2, 4, and 5; 40 dB SL tone was alternated with 60 dB tone in opposite ear in condition 3; tone intermittently increased from 40 dB to 60 dB in condition 6 (see text for details). (From Ref. 3)

Key Terms

Adaptation; loudness adaptation; sound intensity

General Description

Loudness adaptation is a decrease in loudness during prolonged stimulus presentation. Loudness adaptation occurs only when the stimulus is a steady sound within ~30 dB of threshold, when a steady tone is intermittently increased in intensity, or when the steady tone is accompanied by an intermittent sound of higher intensity.

Methods

Test Conditions

Study 1 (Ref. 1)

- Continuous 4000-Hz tone presented **monaurally** or **binaurally**
- Subject estimated tone loudness every 20 sec in response to visual cue; figure shows estimated loudness after 2 min
- Three test sessions

Study 2 (Ref. 3)

- In **anechoic room**, continuous 1000-Hz tone presented through either loudspeaker or earphones

- Tones presented under following conditions: alone at 10 dB above threshold (Conditions 1 and 4), alone at 50 dB above threshold (Conditions 2 and 5), 40-dB tone presented to right ear and periodic 60-dB tone presented to left ear in 15 sec on, 5 sec off cycle (loudness measurements made only during 5-sec intervals tone was in right ear only) (Condition 3); and 40-dB tone increased to 60 dB in 15 sec on, 5 sec off cycle (loudness estimates made only when tone was at 40 dB) (Condition 6)
- Subject entered judgment into computer terminal at signaled

intervals

Experimental Procedure

Study 1

- Beginning threshold for each session measured by two-interval forced-choice procedure
- Independent variables: monaural or binaural tone presentation, sensation level (intensity) of tone
- Dependent variable: mean percentage change in loudness over time
- Subject's task: estimate loudness of tone
- 8 subjects

Study 2

- Method of successive magnitude estimations
- Independent variables: mode of tone presentation, sensation level (intensity) of tone, exposure duration
- Dependent variable: mean percentage decrease in loudness over time
- Subject's task: estimate loudness of tone during 5-sec periods every 20 sec
- Ten estimates per point
- 10 subjects

Experimental Results

- Over intensities of 5-30 dB sensation level (SL) (i.e., 5-30 dB above threshold), loudness adaptation to a 4000-Hz tone increases as tone intensity increases. After 2-min exposure, the percent decrease in loudness of a 5-dB tone approaches 100% (i.e., the tone becomes nearly inaudible); the loudness of a 30-dB tone does not decrease significantly over the same time period.
- The loudness of a continuous 1000-Hz tone at 50-dB SL does not change over a 3-min period (conditions 2 and 5 in Fig. 2), while the loudness of a 10-dB SL tone decreases by ~65% (conditions 1 and 4).
- The loudness of a 40-dB tone decreases over time if its

intensity is intermittently increased to 60 dB or if an intermittent 60-dB tone is presented to the opposite ear (Fig. 2, conditions 3 and 6).

Variability

In Study 2, standard deviations of the mean were approximately 30%.

Repeatability/Comparison with Other Studies

There are many reports of considerable loudness adaptation, but most are based on interaural loudness matching involving presentation of steady sound to one ear and intermittent sound to the other. Other procedures show no loudness adaptation in subjects with normal hearing.

Constraints

- Certain physiological anomalies, e.g., retrocochlear lesions, may result in more general loudness adaptation.
- The data obtained may not be valid for more prolonged periods of auditory stimulation or for signals having complex acoustic spectra.

- Many factors influence judged loudness and must be considered in applying these results under different conditions (CRef. 2.601).
- Several studies have shown large individual differences in loudness adaptation.

Key References

- *1. Scharf, B. (1983). Loudness adaptation. In J. V. Tobias & E. D. Schubert (Eds.), *Hearing research and theory*. New York: Academic Press.
2. Scharf, B., Canévet, G., &

- Botte, M.-C. (1983). Récupération après adaptation induite de sonie. *L'Année Psychologique*, 83, 9-24.
- *3 Scharf, B., & Houtsma, A. (1986). Audition II: Loudness, pitch, localization, aural distortion, pathology. In K. R. Boff, L. Kaufman, & J. P. Thomas (Eds.),

Handbook of perception and human performance. Vol. 1. *Sensory processes and perception*. New York: Wiley.

4. Stokinger, T. E., Cooper, W. A., Jr., Meissner, W. A., & Jones, K. O. (1972). Intensity, frequency, and duration effects in the

measurement of monaural prestimulatory loudness adaptation. *Journal of the Acoustical Society of America*, 51, 608-616.

5. Wright, H. N. (1964). Temporal summation and backward masking. *Journal of the Acoustical Society of America*, 36, 927-932.

Cross References

- 2.601 Factors influencing loudness; *Handbook of perception and human performance*, Ch. 15, Sect. 1.2

2.613 Loudness Discomfort Level

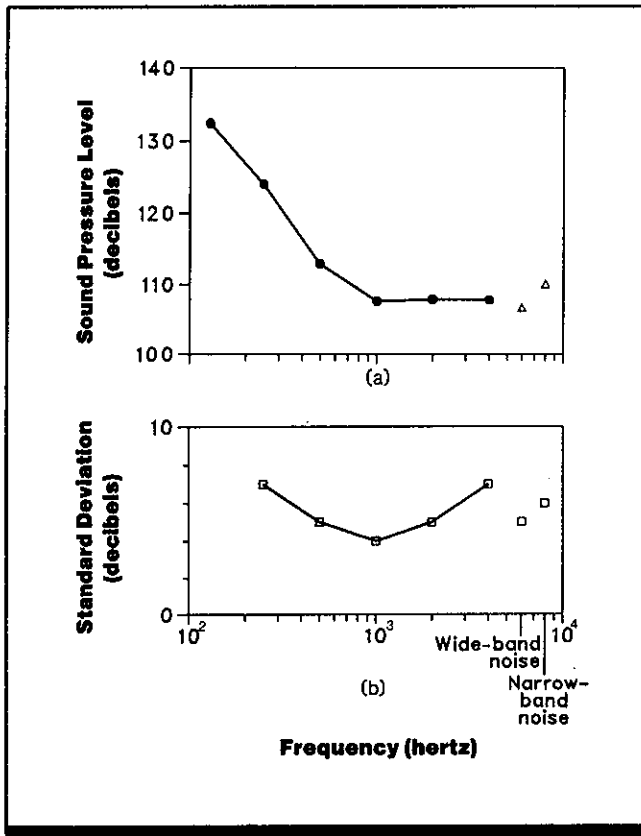

Figure 1. (a) Loudness discomfort level for tone bursts of various frequencies (filled symbols) and for noise of two bandwidths (open symbols). (b) Standard deviations of the means shown in panel (a). (From Ref. 2)

Key Terms

Broadband noise; loudness discomfort level; narrow-band noise; sound intensity

General Description

The intensity level at which the loudness of a sound becomes uncomfortable is fairly constant for tone bursts over the range of 125-4000 Hz and for both narrow- and wide-band noise.

Methods

Test Conditions

- Loudness discomfort level judgments made for tones of 125, 250, 500, 1000, 2000, and 4000 Hz, narrow-band noise (400 Hz wide centered on 1000 Hz), and wide-band noise (90-4990 Hz) during three ~40-min sessions

- Tones presented through earphones
- Subject seated in auditory test booth

Experimental Procedure

- Method of constant stimuli; each stimulus presented 120 times per session over a 10-dB range

- Independent variables: tone frequency, bandwidth of noise
- Dependent variable: loudness discomfort level, defined as the intensity level judged uncomfortable on 50% of trials, determined for each subject by **probit analysis** of the data; figure plots means across all subjects
- Subject's task: press one button if

tone "at loudness to which you would not listen," and another button if below that level

- 9 young adult subjects (mean age of 20) with air conduction thresholds no poorer than 15 dB above (standard) **hearing threshold level** at octave frequencies between 125 and 4000 Hz and with measurable bilateral **acoustic reflex**

Experimental Results

- Loudness discomfort levels are nearly constant at ~108 dB SPL for pure tones of 1000-4000 Hz and for noise.
- The apparent increase in loudness discomfort level at low frequencies seen in Fig. 1a is caused by difficulties in accurately calibrating the intensity of low-frequency tones when earphones are used; when corrections are made, discomfort levels are nearly flat across the frequencies used and correspond closely to the pattern of equal loudness contours (CRef. 2.603).

Constraints

- The results may not be valid for continuous tones presented for prolonged durations.
- The results may not be valid for frequencies >4000 Hz.
- Measurements of loudness discomfort levels may be dependent on the definition of loudness discomfort and the method of measurement.

Key References

1. Hood, J. D., & Poole, J. P. (1966). Tolerable limits of loudness: Its clinical and physiological significance. *Journal of the Acoustical Society of America*, 40, 47-53.

*2. Morgan, D. E., Wilson, R. H., & Dirks, D. D. (1974). Loudness discomfort level: Selected methods and stimuli. *Journal of the Acoustical Society of America*, 56, 577-581.

3. Stephans, S. D. G., & Anderson, C. M. B. (1971). Experimental studies on the uncomfortable loudness level. *Journal of Speech and Hearing Research*, 14, 267-270.

Cross References

2.603 Effect of frequency on the loudness of pure tones;

10.311 Factors affecting the temporary threshold shift;

10.315 Factors affecting noise-induced permanent threshold shift; *Handbook of perception and human performance*, Ch. 15, Sect. 1.2

Variability

Standard deviations are shown in Fig. 1b.

Repeatability/Comparison with Other Studies

Reference 1 obtained loudness discomfort levels of 95-98 dB SPL for monaural tones of 500-4000 Hz. Loudness discomfort was 108 dB SPL for a pulsed 1000 Hz tone presented monaurally and 102 dB for binaural presentation in Ref. 3.

2.701 Factors Affecting Pitch

Key Terms

Adaptation; amplitude envelope; amplitude modulation; auditory masking; displacusic; sound frequency; sound intensity

General Description

While the terms *frequency* and *pitch* sometimes are treated as synonyms, it is important to maintain a distinction between the two terms. Frequency is a physical property of sound, while pitch is a subjective property, defined as "that attribute of auditory sensation in terms of which sounds may

be ordered on a scale extending from high to low" (Ref. 1). Although frequency is perhaps the most important determinant of pitch, it is not the only one. The table lists several factors that affect the experience of pitch, briefly describes the effect of each factor, and cites entries where more information can be found.

Constraints

- Interaction may occur among the various factors affecting the experience of pitch.
- The magnitudes of effects may vary depending on the physiological status of the ear.

Key References

1. American National Standards Institute (ANSI). (1973). *American national psychoacoustical terminology* (Report No. S3.20). New York: ANSI.

2. Scharf, B., & Houtsma, A. J. M. (1986). Audition II: Loudness, Pitch, Localization, Aural Distortion, Pathology. In K. R. Boff, L. Kaufman, & J. P.

Thomas (Eds.), *Handbook of perception and human performance: Vol. 1. Sensory processes and perception*. New York: Wiley.

Cross References

2.702 Effect of frequency on pitch;
2.703 Effect of an interfering stimulus on the pitch of pure tones;

2.705 Effect of amplitude envelope on the pitch of pure tones;
2.706 Binaural pitch disparity (displacusic);

2.707 Pitch shift following adaptation to a tone;
2.711 Pitch of amplitude-modulated (square-wave gated) noise

Factor	Effect on Pitch	Reference
Frequency	Other things being equal, pitch increases as frequency increases, but the relation of pitch and frequency is nonlinear	CRef. 2.702
Intensity	As intensity increases, the pitch of low-frequency tones shifts downward and the pitch of high-frequency tones shifts upward	Ref. 2
Presence of interfering sounds	Pitch of pure tones tends to decrease in the presence of higher-frequency tones and sounds increase in the presence of lower-frequency tones	CRef. 2.703
Adaptation	Adapting tone presented for 1 min or more can cause small change in pitch of subsequent pure tone in direction away from adaptation frequency; effect typically lasts ~30 sec	CRef. 2.707
Stimulus envelope	Tone with an amplitude envelope that decays exponentially has higher perceived pitch than same-frequency tone with rectangular envelope	CRef. 2.705
Ear to which sound presented	Pure tone may have slightly different pitch in the two ears (displacusic); magnitude of pitch difference varies with frequency	Ref. 2.706
Frequency of amplitude modulation of noise	Periodically interrupted noise may have pitch corresponding to rate of interruption up to ~200 per sec	CRef. 2.711

Notes

✓

✓

✓

✓

2.702 Effect of Frequency on Pitch

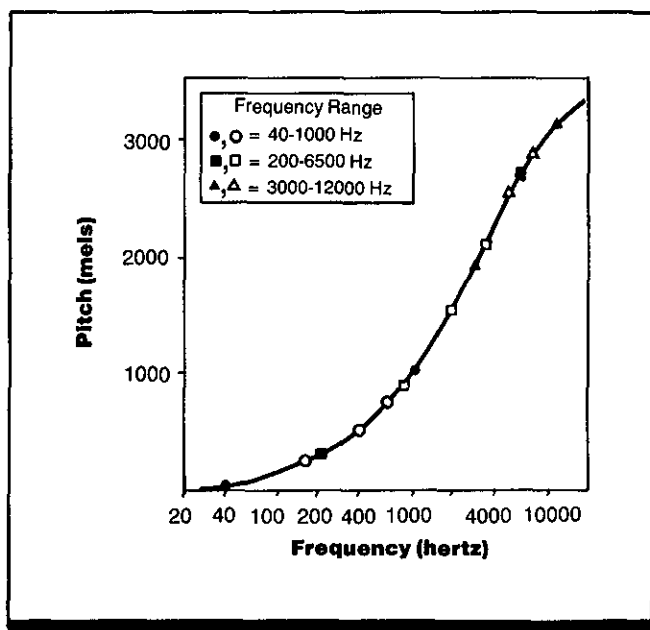

Figure 1. A scale for pitch in mel units (see text) as a function of frequency. Solid symbols mark end points of three frequency ranges that subjects divided into four intervals. The equal intervals set by subjects are represented by open symbols. (From Ref. 6)

Key Terms

Mel scale

General Description

The pitch of a pure tone rises as the frequency of the tone rises, but the relationship is nonlinear. The scale in Fig. 1 shows this relationship in mel units, where a mel is defined as one thousandth of the pitch of a 1000-Hz tone.

Applications

The mel scale, which is an interval-type scale, can be used to predict perceived frequencies of pure tone.

Methods

Test Conditions

- Pure tones produced by pressing key on keyboard with 20 wooden keys; small knob above each key controlled frequency for the key; total possible range for keyboard was 0-15,000 Hz
- Loudness level for all frequencies was ~50 dB; large speaker was ~2 m (7 ft) in front of subject

and small "crystal" speaker was ~1 m (3 ft) in front of subject

- For the equal interval (equal sense-distance) experiment, two keys on a piano tuned to lowest and highest frequencies for selected range (200 and 6500 Hz, 40 and 1000 Hz, or 3000 and 12,000 Hz); subject tuned frequencies for three intermediate keys until total range was divided into four equal intervals

- For the fractionation experiment, two 2-sec tones alternated at 2-sec interstimulus-onset intervals; subject tuned knob to adjust frequency of second tone until it was half the pitch of the first (reference) tone (150, 250, 500, 1000, 2000, 3000, 5000, or 10,000 Hz); subject could turn on a 40-Hz tone to use as nearly zero reference pitch, except when fractionating the 150-Hz tone

Experimental Procedure

- Independent variables: frequency range for equal intervals, frequency of reference tone for fractionation
- Dependent variable: pitch (frequency) as set by subject
- Subject's task: divide frequency range into four equal intervals or set pitch of one tone at one-half pitch of a reference tone
- 10 subjects for equal intervals; 12 subjects for fractionation

Experimental Results

- The perceived pitch of a pure tone increases as the frequency of the tone increases; however, this relationship is not linear (Fig. 1).
- Figure 1 shows results for the equal-interval experiment only; results from the fractionation experiment show excellent agreement.

Constraints

- There is some effect of method (e.g., in another experiment of Ref. 6, the presence of a zero-pitch reference tone tended to lower pitch judgments in relation to judgments without such a reference).
- Many factors influence pitch and should be considered

Key References

1. Beck, J., & Shaw, W. A. (1962). Magnitude estimations of pitch. *Journal of the Acoustical Society of America*, 34, 92-98.
2. Beck, J., & Shaw, W. A. (1963). Single estimates of pitch magnitude. *Journal of the Acous-*

tical Society of America, 35, 1722-1724.

3. Lorenz, C. (1890). Untersuchungen über die Auffassung von Tondistanzen. *Philosophical Studies*, 6, 26-103.
4. Münsterberg, H. (1892) *Beiträge zur experimentellen Psychologie*, 4, 147-177.

Variability

When variability is expressed in terms of the average deviation as a percentage of the mean, average within-subject variability is 9.9% and average between-subject variability is 6.5% for the equal-interval experiment and 15.6% and 9.4%, respectively, for the fractionation experiment. For fractionation, average deviation increases with increasing frequency and the relation appears linear.

in applying these data under different conditions (CRef. 2.701).

Repeatability/Comparison with Other Studies

The mel scale for pitch in Fig. 1 strongly agrees with the data in Ref. 5, and is in fair agreement with the data in Refs. 3 and 4.

5. Pratt, C. C. (1928). Bisection of tonal intervals larger than an octave. *Journal of Experimental Psychology*, 11, 17-26.

*6. Stevens, S. S., & Volkman, J. (1940). The relation of pitch to frequency: A revised scale. *American Journal of Psychology*, 53, 329-353.

7. Stevens, S. S., Volkman, J., & Newman, E. B. (1937). A scale for the measurement of the psychological magnitude pitch. *Journal of the Acoustical Society of America*, 8, 185-190.

Cross References

2.701 Factors affecting pitch;
Handbook of perception and human performance, Ch. 15, Sect. 2.0

2.703 Effect of an Interfering Stimulus on the Pitch of Pure Tones

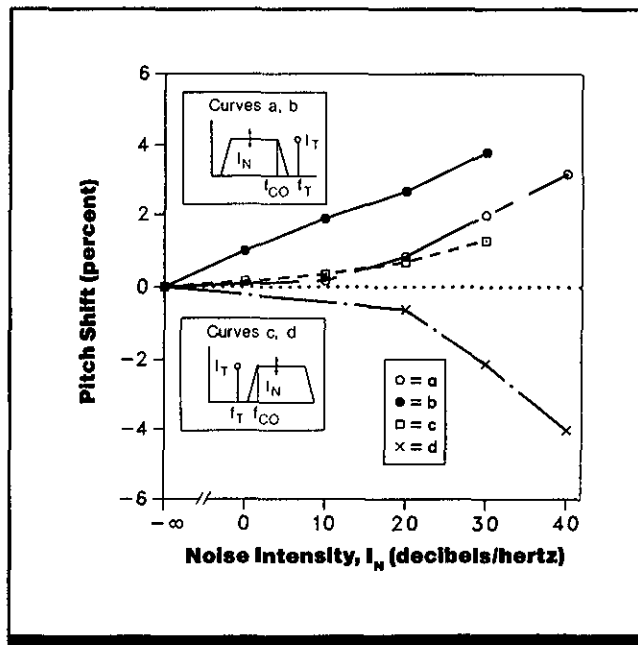
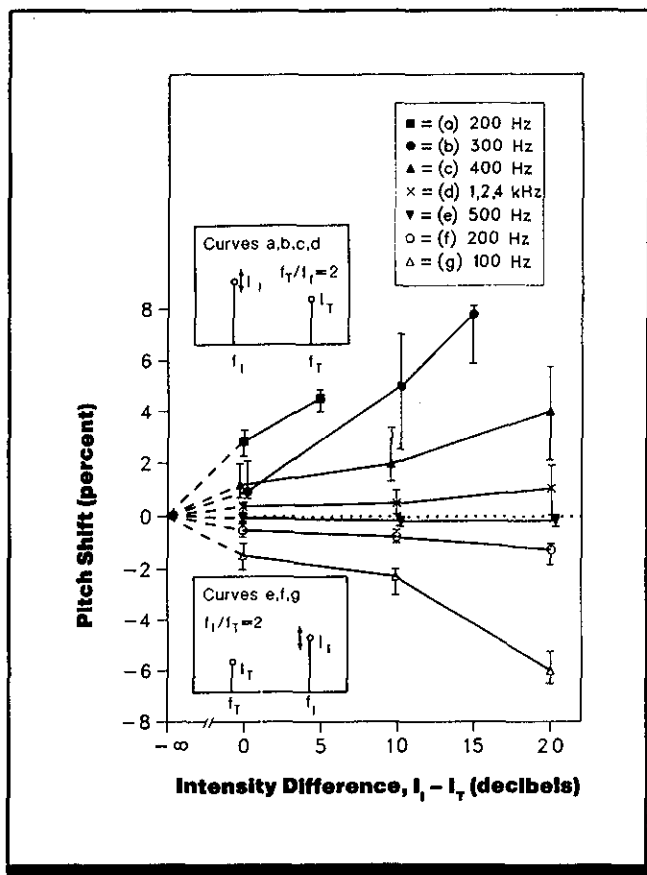

Figure 1. Pitch shift of one sinusoidal tone induced by presence of another sinusoidal tone (Exp. 1). Subject adjusted comparison-tone frequency (f_c) to match pitch of test tone having frequency f_T and intensity of I_T in presence of an interfering tone of frequency f_i and intensity I_i . Percentage pitch shift, $100(f_c - f_T)/f_T$, is plotted as a function of difference in interfering-tone and test-tone intensities. Curves show results for test tones of different frequencies. Curves a-d represent interfering frequencies below test-tone frequency; curves e-g represent interfering frequency above test tone frequency (see insets). Data are medians of eight matches; bars mark ranges with high and low extremes eliminated. (From Ref. 2)

Figure 2. Pitch shift of sinusoidal test tone induced by presence of bandpass noise spectrally located below (Curves a, b) or above (c, d) test-tone frequency (Exp. 2). Percentage pitch shift, $100(f_c - f_T)/f_T$, is plotted as a function of spectral density of noise band. Test tone and nearest noise edge frequencies, respectively, were 300 and 250 Hz (Curve a), 3800 and 2800 Hz (b), 3400 and 3600 Hz (c), and 100 and 125 Hz (d). (From Ref. 2)

Key Terms

Auditory interference; auditory masking; bandpass noise; pitch shift

General Description

The pitch of a pure tone can be changed by introducing a second pure tone or a bandpass-filtered noise. The magnitude of shift can be as large as several percent, but does not always occur. The direction of the shift varies and is af-

ected by the frequency relationship between the test tone (which exhibits the induced pitch shift) and the interfering tone or noise. Some effects are consistent (e.g., a lower-frequency interfering noise raises the pitch of the test tone at higher intensities).

Methods**Test Conditions**

- Experiment 1: sinusoidal test and interfering tones presented simultaneously with positive waveform maxima coinciding; interfering tone frequency was one octave above or one octave below test tone frequency; adjustable-frequency comparison tone also presented;

test and comparison tones always at 50 phons; intensity of interfering tone varied

- Experiment 2: sinusoidal test tone presented simultaneously with bandpass noise spectrally located just below or just above test tone frequency; adjustable-frequency comparison tone also presented; intensity of test and comparison tones always 50 dB sound pressure level (SPL); intensity of noise varied

- Tones presented **monaurally**
- Subject switched between test/interfering tone test/noise combination and comparison tone

quency, nearest noise edge frequency (Exp. 2)

- Dependent variable: frequency of comparison tone judged equal in pitch to test tone
- Subject's task: adjust frequency of comparison tone to match pitch of test tone
- Up to 5 subjects from some comparisons and 8 subjects for others (Exp. 1)

Experimental Procedure

- Independent variables: intensity difference between test tone and interfering tone, frequency of test tone (Exp. 1); spectral density of noise band (dB/Hz), test tone fre-

Experimental Results

- The pitch of a pure tone increases in the presence of an interfering tone of lower frequency.
- If the interfering tone is higher in frequency than the test tone, the pitch of the test tone is shifted downward for low-frequency test tones but not for higher-frequency tones.
- The pitch of a pure tone is shifted upward when it is presented together with interfering noise of a lower frequency.
- When the masking noise is higher in frequency than the

tone, the shift in the pitch of the tone depends on the frequency region of the tone.

Variability

Bars in Fig. 1 represent the range of the middle six of eight matches in Exp. 1; variability data for Exp. 2 not available.

Repeatability/Comparison with Other Studies

Data are typical of those obtained in studies of pitch shifts in presence of masking sounds.

Constraints

- Interfering stimuli of higher frequency than test tone appear to have less consistent effects than interfering stimuli of lower frequency.

- Results may not be valid for other test frequency/interfering frequency combinations.

- Many factors influence pitch and should be considered in applying these data under different conditions (CRef. 2.701).

Key References

1. Békésy, G. von. (1960). *Experiments in hearing*. New York: McGraw-Hill.

*2. Terhardt, E., & Fastl, H. (1971). Zum Einfluss von Störtönen und Störgeräuschen auf die Tonhöhe von Sinustönen. *Acustica*, 25, 53-61.

Cross References

2.701 Factors affecting pitch; *Handbook of perception and human performance*, Ch. 15, Sect. 2.1

2.704 Pitch Recognition with Interpolated Tones

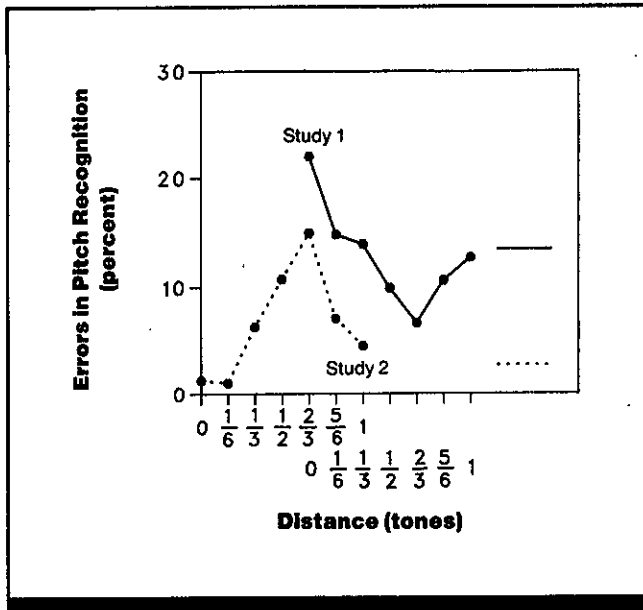

Figure 1. Accuracy in recognizing whether two test tones have the same pitch when they are separated by six intervening tones. In Study 1, a critical tone $2/3$ of a scale tone removed from the standard tone always appeared as the second interpolated tone; pitch recognition errors are plotted as a function of the distance (in scale tones) between this tone and a second critical tone (in the fourth intervening position) which was further removed from the standard along the pitch continuum. In Study 2, the six interpolated tones contained only one critical tone, whose frequency relationship to the standard tone was varied; errors are plotted as a function of the distance of this tone (in scale tones) from the standard tone. (From Ref. 4)

Key Terms

Auditory interference; pitch recognition

General Description

When two sequentially presented tones (standard, then comparison) must be judged as same or different, the disruptive effect of a tone inserted between the two varies systematically with its pitch relationship to the standard tone. Maximal disruption occurs when an interpolated tone is $2/3$ of a musical scale tone away from the standard. When a

second tone $2/3$ scale tone away from the disruptive tone (and $4/3$ tone removed from the standard) is also interpolated between the standard and comparison test tones, substantial recovery of recognition for the standard occurs. This suggests mutual inhibitory interaction between frequency-sensitive mechanisms in the auditory system.

Methods

Test Conditions

Study 1

• Loudspeaker delivery of sinusoidal, test tone (standard tone and comparison tone) and interpolated tones (critical tone and others); standard tone followed by six intervening tones, then comparison tone; all tones 200 msec in duration, 300-msec pauses between tones, except 2-sec interval before second test tone, 10-sec pauses between sequences; 5-min break between groups; eight conditions; 96 sequences (eight groups of 12) per session; two sessions

• 12 test tones taken from an equal-tempered scale, ranging from middle C to B above (tone frequencies were 259, 274, 290, 308, 326, 345, 366, 388, 411, 435, 461, 488 Hz); comparison tone was same or one semitone higher or lower than standard (12 semitones = one octave)

• Critical interpolated tones were in second and fourth intervening positions; critical tone in second position was 2/3 scale tone removed from standard; seven fourth-position tone pitches in 1/6-scale-tone steps forming critical frequency relation with second interpolated tone; control (baseline)

condition fourth tone same as tones in other intervening positions

• Noncritical interpolated tone (all but second and fourth intervening positions) taken from same scale as test tones or randomly from two-octave range (F# below middle C to F an octave and a half above); no repeated or one-octave-separated interpolated tones; none <5 semitones from standard on side of critical tones, 3 on other side

Study 2

• Same as Study 1 except seven second-position critical tones in 1/6-tone steps; baseline condition with second intervening tone from noncritical-tone group

Experimental Procedure

• Repeated measures, counterbalanced order of conditions, forced-choice, same-different judgments of test tones

• Independent variables: Study 1: pitch relation between two interpolated tones; Study 2: pitch relation between standard and interpolated tone

• Dependent variable: percent error in same-different judgments

• Subject's task: indicate whether test tones (standard tone and comparison tone) were same or different pitch

• 21 college students for Study 1; 23 students for Study 2

Experimental Results

• When both test tones are the same, correct judgments occur least often when the pitch of the second critical tone (fourth position) is the same as the pitch of the first critical tone (second position) (solid line, Fig. 1).

• The error rate for "same" test tone judgments declines as the second critical tone pitch approaches a 2/3 scale tone relation with the first critical tone, and increases slightly thereafter (solid line, Fig. 1).

• The error rate when the two critical tones are separated by 2/3 scale tone in pitch is significantly lower ($p < 0.01$) than in the baseline condition, where only the second position tone is in a critical relation to the standard.

• The error rate for "same" test tone judgments increases as pitch separation increases to 2/3 scale tone between the critical tone (second position tone) and the standard tone. At its maximum, the error rate is significantly higher than baseline, that is, the error rate when the second interpo-

lated tone bears no critical relation to the standard tone ($p < 0.005$) (dotted line, Fig. 1).

• The error rate returns to baseline when the critical tone is separated from the standard tone by a whole scale tone (dotted line, Fig. 1).

Variability

No information on variability was given.

Repeatability/Comparison with Other Studies

A peak error rate at a critical value of 2/3-scale-tone separation between standard and interpolated tones was also found for test tones differing in pitch by 1/2 or 2/3 scale tone (Ref. 3). Other psychophysical evidence indicating lateral inhibition in the auditory system has been reported (Ref. 1). When a critical tone that has the same pitch as the comparison is interpolated, there is a tendency to misjudge the second tone as being the same as the standard.

Constraints

• Lengthening the retention interval between the test tones increases the error rate (Ref. 5).

• Increasing the number of interpolated tones causes a decrement in performance (Ref. 2).

• Many factors affect pitch and should be considered in applying these data under different conditions (CRef. 2.701).

Key References

1. Carterette, E. C., Friedman, M. P., & Lovell, J. D. (1969). Mach bands in hearing. *Journal of the Acoustical Society of America*, 45, 986-998.

2. Deutsch, D. (1970). Tones and numbers: Specificity of interference in short-term memory. *Science*, 68, 1604-1605.

3. Deutsch, D. (1972). Mapping of

interactions in the pitch memory store. *Science*, 175, 1020-1022.

*4. Deutsch, D., & Ferree, J. (1975). Disinhibition in pitch memory. *Perception & Psychophysics*, 17, 320-324.

5. Koester, T. (1945). The time error in pitch and loudness discrimination as a function of the time interval and stimulus level. *Archives of Psychology*, 297.

Cross References

2.701 Factors affecting pitch;

2.703 Effect of an interfering stimulus on the pitch of pure tones;

Handbook of perception and human performance, Ch. 32, Sect. 2.6

2.705 Effect of Amplitude Envelope on the Pitch of Pure Tones

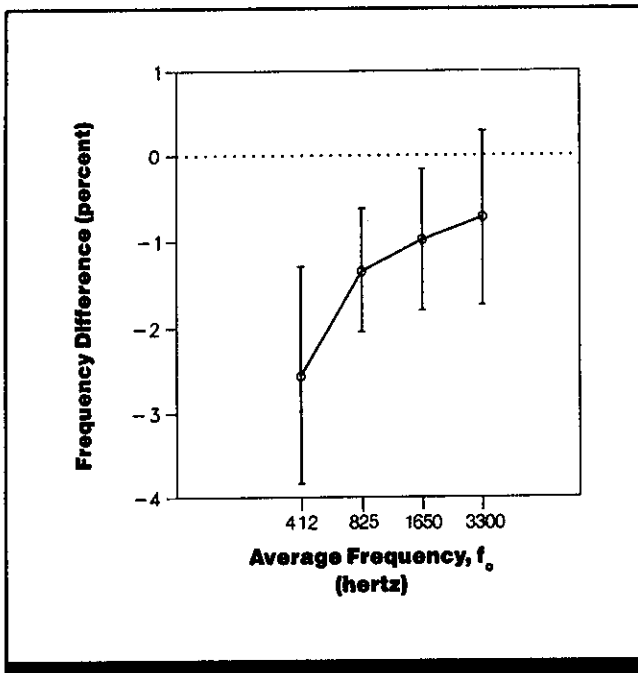

Figure 1. Percentage frequency difference between tones with exponential amplitude envelopes and tones with rectangular envelopes that have equal pitch, as a function of the average frequency of the tones. Negative values on the ordinate mean that a tone with an exponentially decaying envelope has a higher pitch than a tone of the same frequency with a rectangular envelope; bars indicate ± 1 standard deviation for a typical subject. (From Ref. 1)

Key Terms

Amplitude envelope

General Description

A pure tone whose amplitude decays exponentially has a pitch that appears higher than that of a tone of the same frequency with a rectangular envelope. Envelope has a greater effect on pitch for low tone frequencies than for high frequencies.

Methods

Test Conditions

- Each trial contained two sine-wave tones, one with 20-msec rectangular envelope and the other with an exponential envelope that decayed 120 dB over 120 msec, separated by 500-msec interval; which tone appeared first alternated randomly
- Tone with rectangular envelope had intensity of 89 dB sound pres-

sure level (SPL); initial amplitude of exponential envelope was 95 dB SPL; tones sounded equal in loudness and duration and had equal energy

- Frequency of rectangular tone varied; in the 825-Hz range, frequencies were 800, 810, 815, 825, 830, 835, 840, 845, and 850 Hz; in the 412-, 1650-, and 3300-Hz ranges these frequencies were multiplied by a factor of the appropriate integral power of 2; frequencies of the exponential-decay tones dif-

fered from the frequencies of the rectangular tones by 0, ± 10 , ± 20 , or ± 30 Hz

- Tones presented **binaurally** (diotically) through headphones in quiet room with constant noise background (10 dB re 20 μ Pa/Hz in band from 0-5000 Hz)

Experimental Procedure

- Two interval forced-choice up-and-down staircase method
- Independent variable: frequency of rectangular tone

- Dependent variable: difference in frequency of exponential and rectangular tones appearing to have equal pitch (measured as 50% point on psychometric functions derived from data)
- Subject's task: press button to indicate whether first or second interval contained tone with higher pitch; subjects instructed to disregard differences in quality of the two tones
- 3 subjects

Experimental Results

- A tone with an exponentially decaying amplitude envelope sounds higher in pitch than a tone of the same frequency with a rectangular envelope.
- The effect of envelope is greater for lower-frequency tones, with a pitch shift of nearly 3% at the lowest frequency tested.

Variability

The bars in Fig. 1 represent plus or minus one standard deviation for a typical subject.

Repeatability/Comparison with Other Studies

The authors report that further experiments have shown that the pitch shift is not affected by low-pass filtering of the rectangular tone or by truncating the exponential tone, and argue that the pitch shift is not an artifact of experimental arrangements.

Constraints

- The results may not be valid for frequencies outside the range tested.
- Many factors influence pitch and should be considered in applying these data under different conditions (CRef. 2.701).

Key References

*1. Hartmann, W. M. (1978). The effect of amplitude envelope on the pitch of sine wave tones. *Journal of the Acoustical Society of America*, 63, 1105-1113.

2. Sharf, B., & Houtsma, A. J. M. (1986). Audition II: Loudness, pitch, localization, aural distortion, pathology. In K. R. Boff, L. Kaufman, & J. P. Thomas

(Eds.), *Handbook of perception and human performance: Vol I. Sensory processes and perception*. New York: Wiley.

Cross References

2.701 Factors affecting pitch;
Handbook of perception and human performance, Ch. 15, Sect. 2.1

2.706 Binaural Pitch Disparity (Diplacusis)

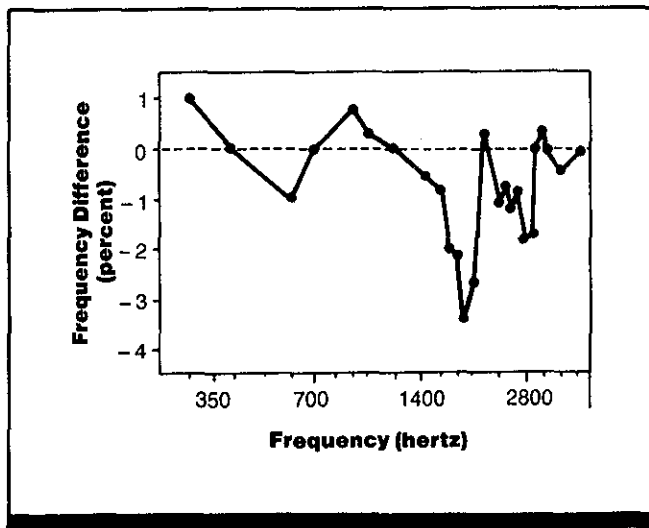

Figure 1. Binaural pitch disparity for a subject with normal hearing. When a tone to the right ear had the frequency shown on the horizontal axis, a tone of equal intensity to the left ear had to be increased or decreased in frequency by the percentage shown on the vertical axis for the two tones to appear equal in pitch. Thus, the ordinate shows the amount of diplacusis. (From Ref. 1, based on data from Ref. 2)

Key Terms

Binaural pitch disparity; diplacusis binauralis

General Description

Diplacusis binauralis is a condition in which the same tone produces different pitch sensations in the two ears. While such pitch differences are most readily noticeable in defective ears, a moderate amount of diplacusis occurs in those whose ears are normal as determined by standard audiometric methods.

Methods

Test Conditions

- One pure tone presented to each ear; presentation of tones alternated; tones equal in intensity

- Subject pressed one of two keys to hear each of the two tones for a trial; subject could adjust frequency of tone in left ear (test tone); frequency of tone in right ear (reference tone) fixed by experimenter

Experimental Procedure

- Independent variables: frequency of reference tone, intensity
- Dependent variable: frequency of test tone at which it appears equal in pitch to reference tone in other ear

- Subject's task: adjust frequency of tone in left ear so that its pitch matched the pitch of the tone in the right ear
- 7 subjects

Experimental Results

- The pitch of a tone of given frequency is not necessarily the same in the two ears; at some frequencies, the two ears are matched, but at other frequencies, the frequency of the tone in one ear may have to be changed by several percent relative to the frequency of the tone in the other ear to produce an equal pitch sensation.
- Generally, for any given individual, the tone presented to the right ear seems higher in pitch at some frequencies, while the tone presented to the left ear seems higher at other frequencies. Data for a representative listener are shown in Figure 1.

- The amount of diplacusis generally is greater at low than at high intensities (data not shown here).

Variability

All subjects showed some degree of diplacusis, but the relation of diplacusis to frequency varied among subjects.

Repeatability/Comparison with Other Studies

Diplacusis has been observed in a number of studies. The pattern of diplacusis for a given individual (pitch disparity as a function of frequency) has been found to be very stable over time (Ref. 3).

Constraints

- Diplacusis seems to be more prominent following intense auditory stimulation to one ear, with differences as great as one octave after prolonged exposure to intense tones.
- Many factors influence pitch (CRef. 2.701).

Key References

- | | | |
|---|--|---|
| 1. Morgan, C. T. (1943). <i>Physiological psychology</i> . New York: McGraw-Hill. | *2. Stevens, S. S., & Egan, J. P. (1941). Diplacusis in "normal" ears. <i>Psychological Bulletin</i> , 38, 548 (abstract). | 3. Van den Brink, G. (1970). Experiments on binaural diplacusis and tone perception. In R. Plomp & G. F. Smoorenburg (Eds.), <i>Frequency analysis and periodicity detection in hearing</i> . Netherlands: Sijthoff & Nordoff International Publishers. |
|---|--|---|

Cross References

2.701 Factors affecting pitch;
Handbook of perception and human performance, Ch. 15, Sect. 2

2.707 Pitch Shift Following Adaptation to a Tone

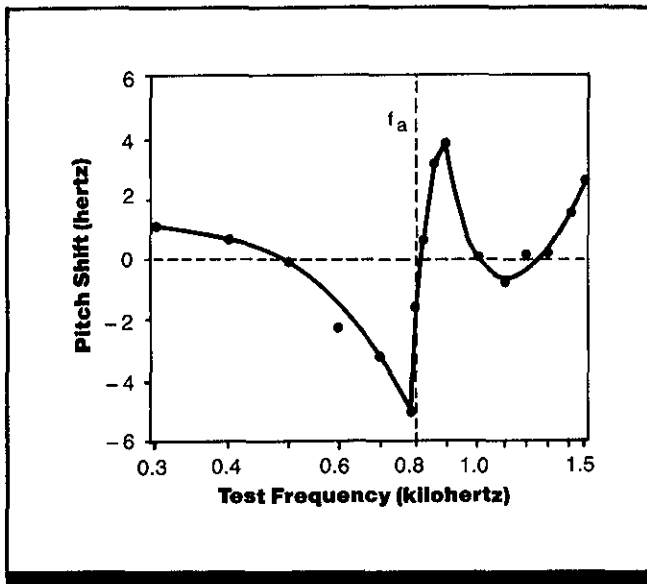

Figure 1. Pitch shift of a pure tone after adaptation to an 800-Hz tone (f_a). Vertical axis shows the amount by which the frequency of a tone to the right ear had to be increased or decreased for it to appear equal in pitch to a test tone of the frequency shown on the horizontal axis delivered to the left ear after adaptation. Data are shown for one subject. The horizontal line at zero represents pitch matching without adaptation with normal pitch differences between the two ears (binaural displaculus) taken into account. (From Ref. 4)

Key Terms

Adaptation; pitch shift

General Description

The pitch of a pure tone can be affected by prior exposure to a tone having a similar frequency. A prior (adaptation) tone presented for 1 min or more can cause a change in the pitch of a subsequent test tone in a direction away from that

of the adapting frequency; within a narrow frequency band surrounding the adapting tone, the pitch of the test tone will shift upward if the frequency of the test tone is higher than that of the adapting tone and downward if the test tone frequency is lower.

Methods

Test Conditions

- Test tone of a given frequency and comparison tone of variable frequency were presented to the left and right ears, respectively; both tones were presented at 70 dB SPL; tones alternated and were separated by 1-sec interval; each was on for 500 msec and had a rise/fall time of 25 msec
- Test tone frequency set to one of several values and the variable-frequency

tone set to one of two starting positions (approximately the interquartile points for the range of the frequency ensemble)

- Each trial consisted of three repetitions of an 8-sec pattern of alternating tones with a 4-sec pause between pattern repetitions; inter-trial intervals were at least 24 sec
- On adaptation trials, a continuous adapting tone of 800 Hz was presented at 80 dB SPL to the left ear for 3 min prior to each trial, was turned off 1 sec prior to trial,

and was turned on during the inter-trial intervals

- Standard trials (without adapting tone) were run during the first half of a 1-hr session and adapting trials were run in the second half
- Tones were presented to acoustically isolated subjects through headphones

Experimental Procedure

- Method of adjustment
- Independent variable: frequency of test tone

- Dependent variable: the difference between the frequency of the variable comparison tone and the frequency of the test tone when the two tones appeared equal in pitch
- Subject's task: adjust frequency of variable comparison tone until it matched pitch of test tone
- 6 subjects with extensive practice provided individual data and 12 unpracticed subjects provided group data; all subjects had musical training and had normal hearing

Experimental Results

- After several minutes of exposure to an adapting tone of 800 Hz, the pitch of a test tone whose frequency falls within a narrow band ($\pm 3.5\%$) around the adapting frequency is shifted away from the adapting frequency.
- For most subjects, frequencies outside this narrow band are unaffected by the adaptation tone. Figure 1 shows data for one subject. The pitch shift at the high end of the frequency scale for this subject was not seen for other listeners.

- The amount of pitch shift was generally $<3\%$ of the test frequency and was stable after 12 sec of adaptation for most subjects.

Variability

Standard errors of the mean for pitch shift were ~ 1.4 Hz. Individual subjects differed in both amount and slope of pitch shift.

Repeatability/Comparison with Other Studies

The results are consistent with those of Ref. 1. The shape of the pitch-shift function is similar to those for other contrast-enhancement phenomena (e.g., Mach bands in vision).

Constraints

- The bidirectional pitch shift may not occur in the presence of simultaneous background stimulation; generally upward shifts have been reported under such circumstances (Ref. 4).
- While the direction of the pitch shift is predictable as a function of the relation between tone frequencies, the amount of pitch shift is not predictable (Ref. 2).

- The amount of pitch shift may vary with the interval between adapting and test tones (Ref. 2).
- Both adaptation and recovery from adaptation are fairly rapid; according to Ref. 3, the magnitude of adaptation approaches asymptote after ~ 30 sec of exposure to the adapting tone and recovery essentially is complete after ~ 30 sec.
- Many factors influence pitch and should be considered in applying these data under different conditions (CRef. 2.701)

Key References

1. Békésy, G. von (1929). Zur Theories des Hörens: Über die Bestimmung des einem reinen tonempfindet entsprechenden Ermüdungserscheinungen. *Zeitschrift für Physik*, 30, 115.

2. Christman, R. J., & Williams, W. E. (1963). Influence of the time interval on experimentally induced shifts of pitch. *Journal of the Acoustical Society of America*, 35, 1030-1033.

3. Hall, J. W., III, & Soderquist, D. R. (1978). Adaptation of residue pitch. *Journal of the Acoustical Society of America*, 63, 883-893.

*4. Larkin, W. D. (1978). Pitch shifts following tone adaptation. *Acustica*, 41, 110-116.

Cross References

2.701 Factors affecting pitch; *Handbook of perception and human performance*, Ch. 15, Sect. 2.

2.708 Pitch Discrimination Under Simultaneous Masking

Key Terms

Complex sound; frequency modulation; harmonics; mistuning; pitch discrimination; signal detection; simultaneous masking

General Description

When a low musical note (complex tone with low fundamental frequency) is presented simultaneously with a high musical note (complex tone with high fundamental frequency), the low tone may mask the high tone (i.e., reduce its discriminability). The degree to which the presence of the low tone will raise the threshold for discriminating the pitch of the high tone depends upon the amplitude of the masking tone, the degree of coincidence of harmonics between low-tone mask and high tone, the amount of mistuning of the high tone relative to the low tone, and the frequency modulation of the high tone.

Applications

Improvement of signal detectability; masking of unwanted sounds.

Methods**Test Conditions****Experiment 1**

- High and low musical tones with identical onset, duration (200 msec) and rise and decay times (20 msec each)
- Proportions of high tone harmonics coincidental with low tone harmonics were 1/1, 1/2, 1/3, 1/4, 1/5 and 1/6
- Phase relationship between coinciding harmonics were: random difference, controlled 90° difference, and in-phase
- Sound pressure level (SPL) of low tone not given
- Type of headphones not specified

Experiment 2

- 500 Hz and 750 Hz high tones

were frequency modulated (at 5 Hz) at a depth of 4%

- Low tone and high tone onset, duration (200 msec) and rise and decay times (20 msec) were identical
- Type of headphones not specified
- No SPL information given

Experiment 3

- Stimuli were pairs of chords, each chord consisting of a high complex tone and a low complex tone, presented in succession
- Low tone frequency always 250 Hz; high tones 500 Hz and 750 Hz, or frequencies differing from these values by ± 0.4 , 0.8, 1.6, 3.2, or 6.4%; order of high tones randomized within chord pairs to form high-low or low-high sequences
- Stimuli onset, duration, and rise

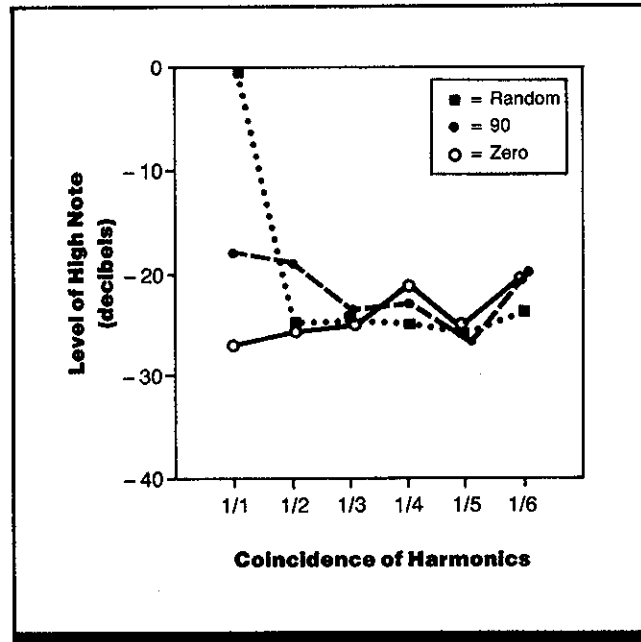

Figure 1. Pitch discrimination of a high tone masked by a low tone as a function of coincidence of harmonics of mask and test tone (Exp. 1). The level of the high tone at discrimination threshold (relative to the level of the masking tone) is shown for different proportions of coinciding harmonics when the phase difference between the harmonic components of test tone and mask was 0 deg, 90 deg, or random. Data are averages for 5 subjects. (From Ref. 2)

and decay times same as Exp. 1

- Type of headphones not specified
- No SPL information given

Experimental Procedure

- Method of constant stimuli, two-alternative forced choice, 180 trials each condition
- Independent variables: proportion of coinciding harmonics; phase relation of high, low tones; frequency modulation of high tone; high tone mistuning

- Dependent variable: threshold for discriminating pitch of high tone, defined as intensity of the high tone at which direction of pitch shift could be identified correctly on 75% of trials
- Subject's task: indicate pitch-jump direction by pushing one of two buttons on response box
- 1-5 subjects, music students, informed in general terms about how high-tone pitch varied

Experimental Results

- If the coincidence of harmonics for two complex tones presented simultaneously is $< 1/2$, neither the amount of coincidence nor the phase relation of the tones affects the threshold intensity for discriminating the pitch of the high tone, which ranges from -20 to -25 dB relative to the intensity of the masking (low) tone (see Fig. 1).
- When all harmonics coincide (1/1), threshold is within this same range when phase differences are 0 or 90 deg, with threshold lowest when harmonics are in phase; but threshold is raised to 0 dB relative to masking tone level when phase difference is random.
- When two pairs of high-tone/low-tone combinations are

presented successively, the threshold for discriminating the two high tones falls as the interval between the two high tones differs increasingly from a perfect interval (see Fig. 2).

- Frequency modulation of a high tone reduces its threshold in the presence of a low-tone mask from 0 dB for non-modulated tones to -17.5 dB for modulated tones (data not shown).

Variability

- No information on variability was given

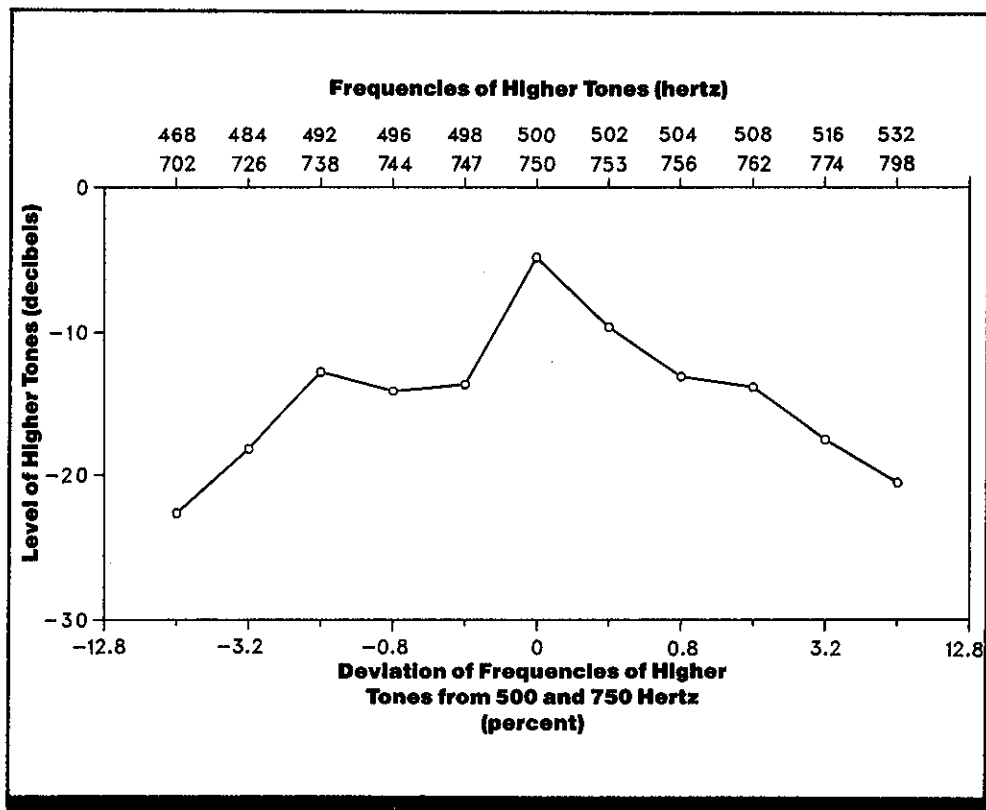

Figure 2. Pitch discrimination of a high tone masked by a low tone as a function of deviation of high tone from a perfect interval (Exp. 3). Level of the high tone at discrimination threshold (relative to the level of the masking tone) is shown as a function of the amount by which the two high tones whose pitch was discriminated deviated from a perfect interval of 250 Hz or 500 Hz with the low-tone mask of 250 Hz. Data are shown for one subject. (From Ref. 1, based on data from Ref. 2)

Constraints

- In practical situations, perfect synchrony of two tones is not possible; onset asynchrony and other temporal characteristics will affect threshold (CRef. 2.709).

Key References

1. Deutsch, D. (1986). Auditory pattern recognition. In K. R. Boff, L. Kaufman, & J. P. Thomas

(Eds.), *Handbook of perception and human performance: Vol. II. Cognitive processes and performance*. New York: Wiley.

*2. Rasch, R. A. (1978). The perception of simultaneous notes such as polyphonic music. *Acustica*, 40, 21-33.

Cross References

2.709 Pitch discrimination under nonsimultaneous masking; *Handbook of perception and human performance*, Ch. 15, Sect. 2.0

2.709 Pitch Discrimination Under Nonsimultaneous Masking

Key Terms

Backward masking; complex sound; frequency; onset asynchrony; pitch discrimination; reverberation; signal detection; stimulus duration

General Description

When a low musical note (complex tone with low fundamental frequency) is presented close in time to a high musical note (complex tone with high fundamental frequency), the low tone may mask the high tone (i.e., reduce its discriminability). The degree to which the presence of the low tone will raise the threshold for discriminating the pitch of the high tone depends on the time delay between the onset of the high test tone and the onset of the low-tone mask, as well as on several other factors (such as the length of the test tone, the rise of the tones, and reverberation time) which interact with mask onset delay.

Methods

Test Conditions

Experiment 1

- Two musical tones (high, low); low tone served as mask
- Low tone was 250 Hz; high tone was 500 Hz or 750 Hz
- Low tone delayed relative to high tone; onset delay varied from 0-30 msec in 10 msec steps
- Low tone duration was 200 msec
- High tone duration was 20 (limited mask) or 200 (complete mask) msec
- 200 msec high tone ended at either 0 or 5 msec after low note
- All tones had 20 msec rise and decay times
- Phase difference between coinciding harmonics was 90°
- Stimuli presented binaurally via headphones (no model information given)
- No sound pressure level (SPL) information given

Experiment 2

- High and low tone frequency same as in Experiment 1
- SPL of the low tone ranged from (-40) - 0 dB in 10 dB steps
- Delay of low tone onset was

0, 15, or 30 msec

- High and low tone durations were 6, 12, 25, 50, 100 and 200 msec
- Absolute low tone frequencies ranged from 62.5-1000 Hz; absolute high tone frequencies ranged from 125-2000 Hz and 187.5-3000 Hz; ratio of low tone frequency to high tone frequency was always 1:2 or 1:3
- Fundamental frequency of low tone ranged from 50-500 Hz
- Low and high tone rise times ranged from 5-100 msec
- Stimuli presented binaurally via headphones (no model information given)

Experiment 3

- Low tone frequency was 250 Hz; high tone frequencies were 500 Hz and 750 Hz
- Phase difference between coinciding harmonics was 90°
- Delay of low tone onset ranged from 0-30 msec in 10 msec steps
- High tone completely overlapped low tone
- Reverberation times of 0.5, 1.5, and 2.5 sec
- Experiment carried out in ane-

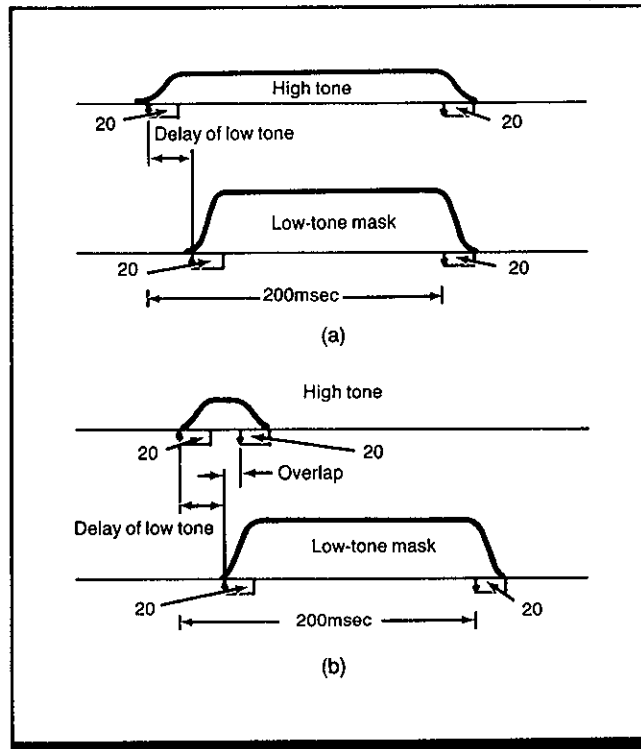

Figure 1. Temporal relations between test (high) tone and masking (low) tone. (a) Test tone begins before masking tone, tones end simultaneously (complete overlap condition). (b) Test tone begins before masking tone and ends shortly after mask onset (short overlap condition). (From Ref. 1)

choic chamber (with reverberation time ~0 sec) and a room with adjustable reverberation time (by sound absorbing blocks)

- Stimuli presented via loudspeakers, 2.5 m from subject

Experimental Procedure

- Method of constant stimuli, two-alternative forced choice, 180 trials each condition
- Independent variables: high tone frequencies; low tone delay; rise times for low, high tones; reverberation time; absolute high tone frequencies, absolute low tone fre-

quencies; low tone fundamental frequency

- Dependent variable: pitch discrimination threshold, defined as the intensity of the high tone at which the direction of the pitch shift could be identified on 75% of trials
- Subject's task: indicate direction of pitch jump of high tone for successive tone pairs
- 1 to 5 music students, subjects informed in general terms about how high tone pitch varied

Experiment Results

- Pitch discrimination threshold for a high complex tone masked by a low complex tone decreases substantially as mask onset is delayed relative to test tone onset; the amount of overlap between test tone and mask has no effect (Fig. 2).
- Level of the masking tone has a large effect only for synchronous stimuli (mask onset delay = 0 msec)(Fig. 3).
- Stimulus duration has little effect on discrimination threshold at any mask onset delay; threshold decreases with

increasing mask onset delay at all stimulus durations.

- Pitch discrimination varies little with absolute frequencies of mask and test tones; threshold decreases with increasing mask onset delay at all frequencies.
- Pitch discrimination varies little with fundamental frequency of the mask; threshold decreases with increasing mask onset delay at all frequencies.
- Loudspeaker presentation with no reverberation produces about the same discrimination threshold as headphone pre-

sensation; thresholds increase with reverberation time for all mask onset delays except 0 msec, but the effect is slight compared with the effects of mask onset delay.

- When the test tone has a shorter rise time than the masking tone, discrimination threshold decreases as the difference between rise times of the test tone and mask increases; the inverse does not hold—when the mask has a shorter rise

time than the test tone, thresholds are the same as when rise times and onset times are equal (Fig. 4).

Variability

- No information on variability given.

Key References

*1. Rasch, R. A. (1978). The perception of simultaneous notes, such as in polyphonic music. *Acustica*, 40, 21-33.

Cross References

2.708 Pitch discrimination under simultaneous masking;

Handbook of perception and human performance, Ch. 15, Sect. 2.; Ch. 32, Sect. 1.1

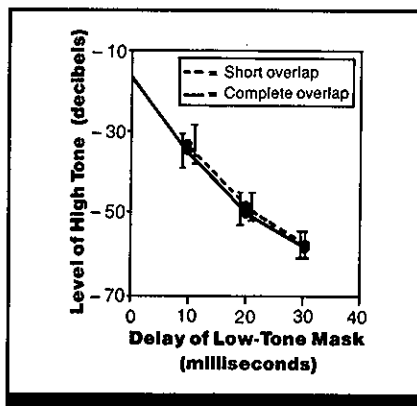

Figure 2. Pitch discrimination threshold for high tone (relative to level of mask) as a function of onset delay of masking tone with short and complete overlap of test tone and mask (Exp. 1). Data are averages for 5 subjects. (From Ref. 1)

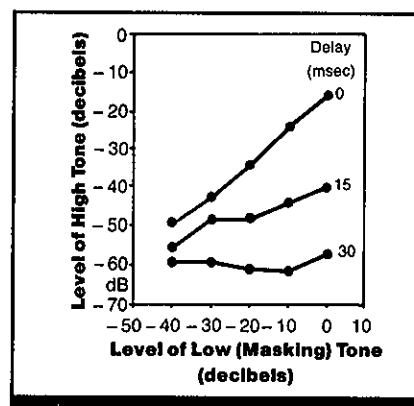

Figure 3. Pitch discrimination threshold for high tone (relative to level of mask) as a function of level of lowtone mask at three mask-onset delays (Exp. 2). Data are averages for 2 subjects. (From Ref. 1)

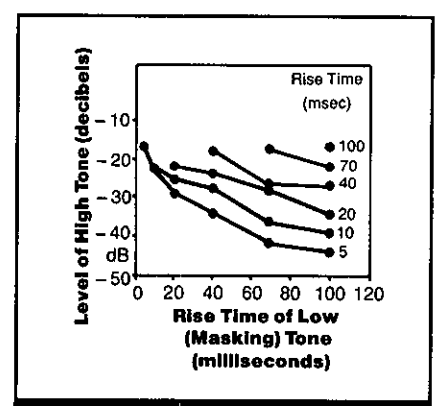

Figure 4. Pitch discrimination threshold for high tone (relative to level of mask) as a function of rise time of the masking tone for different rise times of test tone (Exp. 3). Data points are for one subject for stimuli where rise time of the test tone was shorter than rise time of the masking tone. (From Ref. 1)

2.710 Nontonal Pitch

Key Terms

Adaptation; adaptation pitch; echo pitch; edge pitch; nontonal pitch; repetition pitch

General Description

Periodic sounds, or sounds that have line spectra consisting of harmonically related frequencies, produce the clearest experience of pitch in the listener (e.g., when a note is played on a piano). Some noise-like sounds also evoke sensations of pitch, referred to as nontonal pitch. There are four kinds of nontonal pitch, as described below.

Repetition Pitch (Echo Pitch)

When one or more systematically delayed images of a sound interfere with the original sound waveform (as can happen with sound reflection in an auditorium), one hears a pitch related to the inverse of the time delay. The original sound wave form can be noise, music, speech, or just about any other sound. Because the frequency response characteristic of such a time-delay system has a periodic comblike structure, this process is often referred to as comb filtering.

When a **white noise** and a delayed noise are added in phase, the resulting repetition pitch, RP_0 , can be described by the empirical formula (based on Refs. 1, 2, 5):

$$RP_0 = 1/\tau \quad (1)$$

where τ is the time delay. When the delayed noise is added out-of-phase, two pitches are heard, one slightly above and one slightly below the inverse of the time delay. In this case, repetition pitch RP_{180} is:

$$RP_{180} = 8/7\tau \text{ or } RP_{180} = 6/7\tau. \quad (2)$$

Repetition pitch is audible with time delays ranging from 1-10 msec and is commonly used to produce special effects in recorded or synthesized music. Sometimes it occurs as an

accidental and undesirable effect. For example, if a concert hall or auditorium has a strong reflection that arrives at the listener's ear between 1 and 10 msec after the direct wave front, the listener hears a constant pitch or tone coloration superimposed on the sound.

Edge Pitch

Monaural edge pitch is a pitch sensation evoked by low-pass or high-pass noise of sufficiently sharp spectral edge; such stimuli can be matched to the pitches of pure tones with frequencies slightly in (toward the noise band) from the spectral edge (Refs. 3, 4). Binaural edge pitch is evoked when white noise is presented to both ears with an interaural phase shift of 0 deg below a particular frequency f_0 and 180 deg above f_0 . Under these conditions, two pitches are heard, one slightly above and one slightly below f_0 .

Adaptation Pitch

Adaptation pitch is a weak tonal afterimage heard after the sudden offset of wide-band noise with a spectral notch of about half an octave. The pitch of the afterimage matches the center frequency of the notch. Its duration depends on the duration of noise exposure, but it never lasts more than a few seconds.

Pitch of Amplitude-Modulated Noise

Noise that is periodically amplitude-modulated gives rise to a pitch sensation that can be matched to that of a pure tone or a square wave, with about the same accuracy that the pitch of a square wave can be matched to a pure tone. However, the modulation rate must be below 100 Hz.

Constraints

- Nontonal pitch sensations are typically weak and may not be easily discernible in presence of loud signals.

Key References

- | | | |
|--|--|--|
| <p>1. Bilsen, F. A. (1968). <i>On the interaction of a sound with its repetitions</i>. Unpublished doctoral dissertation. Delft University, the Netherlands.</p> | <p>2. Bilsen, F. A., & Goldstein, J. L. (1974). Pitch of a dichotically delayed noise and its possible spectral basis. <i>Journal of the Acoustical Society of America</i>, 55, 292-296.</p> <p>3. Fastl, H. (1971). Über Tonhöhenempfindungen bei Rauschen. <i>Acustica</i>, 25, 350-354.</p> | <p>4. Klein, M. A., & Hartmann, W. M. (1981). Binaural edge pitch. <i>Journal of the Acoustical Society of America</i>, 67, 1704-1721.</p> <p>*5. Scharf, B., & Houtsma, A. J. M. (1986). Audition II: Loudness, pitch, localization, aural distortion, pathology. In K. R. Boff, L. Kaufman, & J. P. Thomas (Eds.), <i>Handbook of perception and human performance: Vol. 1. Sensory processes and perception</i>. New York: Wiley.</p> |
|--|--|--|

Cross References

2.711 Pitch of amplitude-modulated (square-wave gated) noise

Notes

2.711 Pitch of Amplitude-Modulated (Square-Wave Gated) Noise

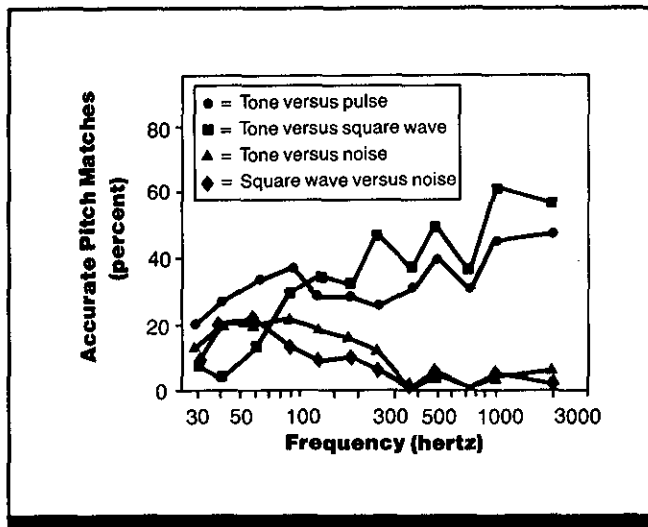

Figure 1. Accuracy of pitch judgments as a function of frequency (Exp. 1). Subjects matched the pitch of a pure tone to the pitch of interrupted (amplitude-modulated) noise, a square wave, or a sequence of pulses; or matched modulated noise to a square wave. Accuracy is defined as the percentage of judgments that fall within a narrow range on either side of the fundamental frequency of the complex sound. (From Ref. 1)

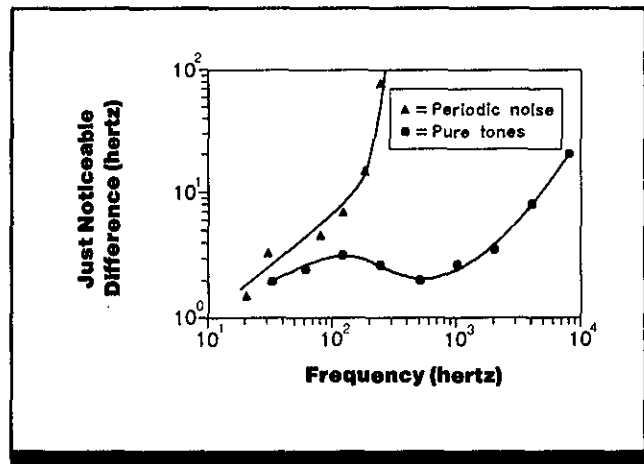

Figure 2. Just noticeable difference in the frequency of interruption of amplitude-modulated noise as a function of modulation rate (triangles) (Exp. 2). For comparison, just noticeable difference in the frequency of a pure tone is also plotted (circles; data from Ref. 2). Convergence of the two functions at low frequencies suggests that a similar temporally based mechanism may operate at frequencies <100 Hz. (From Ref. 1)

Key Terms

Amplitude-modulated noise; complex sound; frequency difference threshold; gated noise

General Description

Noise that is interrupted periodically may be perceived as having a vague pitch that corresponds to the rate of interruption up to a rate of ~200-250 Hz. At higher rates of interruption, sensitivity to changes in the rate of interruption is poor.

Applications

Presentation of intermittent noise.

Methods

Test Conditions

Experiment 1

- Signals were a pure tone alternating with either interrupted noise, a square-wave train, or a series of 40 msec rectangular pulses; all signals were of approximately equal loudness
- Noise interrupted at rates of 30-2000 interruptions per sec, with 50% duty cycle; overall noise sound pressure level (SPL) was 50 or 100 dB

- Sounds presented via earphone, presumably monaurally and in sound-treated room

Experiment 2

- Noise presented monaurally with base interruption rate of 20, 40, 80, 120, 160, 240, or 320 per sec; 50% duty cycle
- Each base rate of interruption alternated with slightly faster rate; increment in interruption rate was reduced until subject detected changed 50% of the time
- Noise level was 50 or 100 dB SPL
- Subject in sound-treated room

Experimental Procedure

Experiment 1

- Independent variable: noise interruption rate
- Dependent variable: percent of judgments falling within frequency band centered on fundamental frequency of the complex sound (band defined as ± 1 just-noticeable increment in the frequency of a pure tone)
- Subject's task: subject adjusted pure tone frequency to same pitch as interrupted noise; in control condition subject matched pure tone to square wave and to series of rectangular pulses and matched fre-

quency of square wave to noise interruption rate

- Subjects instructed in concepts of pitch and timbre
- 10 subjects with some practice

Experiment 2

- Modified method of limits
- Independent variable: base rate of noise interruption
- Dependent variable: threshold for detecting difference in rate of interruption, defined as 50% accuracy of detection
- Subject's task: indicate when rate of noise interruption changed
- 6 subjects

Experimental Results

- When noise is interrupted (amplitude modulated) at <100 Hz, listeners can match the pitch of the interrupted noise to the pitch of a pure tone about as accurately as they can match a pure tone to a square wave or a sequence of pulses.
- At noise modulation rates of ~100-250 Hz, accuracy in matching the frequency of the noise to the frequency of a tone decreases as modulation frequency increases. Matches cannot be made at noise modulation rates >300 Hz (i.e., the interrupted noise has no perceptible pitch).
- Matches are slightly more accurate at noise levels of 100 dB SPL than at 50 dB. (Figure 1 plots data for both noise levels combined.)

- At modulation frequencies <200-300 Hz, the ability to detect changes in the rate of noise interruption is about as good as the ability to detect frequency changes in a pure tone; at higher interruption rates, the ability to discriminate differences in noise modulation frequency disappears.

Variability

Large individual differences were reported for both experiments.

Repeatability/Comparison with Other Studies

The data are consistent with available theories of hearing.

Constraints

- The results may not be valid for duty cycles other than 50%; accuracy in matching tone frequencies to noise interruption rates appears to be greater for duty cycles <50%, with an optimum at ~20%.
- The results may not be valid for noise intensities other than those employed.

- Whether subjects experience a true sensation of pitch for interrupted noise is debated among researchers in the area. Listeners may have been matching the noise interruption frequency to the pure tone frequency without experiencing a true pitch sensation.

Key References

*1. Miller, G. A., & Taylor, W. G. (1948). The perception of repeated bursts of noise. *Journal of the Acoustical Society of America*, 20, 171-182.

2. Shower, E. G., & Biddulph, R. (1931). Differential pitch sensitivity of the ear. *Journal of the Acoustical Society of America*, 3, 275-287.

Cross References

2.710 Nontonal pitch;
Handbook of perception and human performance, Ch. 15, Sect. 2.3

2.801 Sound Localization

Key Terms

Auditory localization; direction; distance; interaural intensity differences; interaural phase differences; interaural time differences; lateralization; spatial localization

General Description

Sound localization refers to the ability to identify the position of a sound source in space. Humans have an excellent sense of localization based primarily on differences between the sounds reaching the two ears, differences that vary with the direction and distance of the sound source relative to the listener. These interaural cues are complemented by **monaural** cues from the external ear (pinna) and from head movements. Intensity, phase, and onset time differences are the major cues for sound localization.

Direction of a sound source

Most studies of localization have examined the accuracy of localizing a sound in the horizontal plane, toward the left and toward the right in front of the listener. The primary bases for discrimination in the horizontal plane are **bin-aural** cues.

Binaural Cues. The location of the ears on each side of the head means that a sound not coming from a source in the median plane (an imaginary two-dimensional surface that splits the head from front to back) reaches the two ears at different times and with different intensities (CRefs. 2.803, 2.805). Given the speed of sound in air and the maximum acoustical distance between the ears, the ear closer to the sound source receives the sound as much as 700 μ sec sooner than the ear farther away. Successive sound waves continue to arrive sooner to the nearer ear. Given the size of the head relative to the wavelength of most audible sounds, the sound in the farther ear may be attenuated at certain frequencies as much as 40 dB relative to the nearer ear (Ref. 1).

These interaural time and intensity differences provide the primary cues for sound localization, but their utility depends strongly on the spectral content of the sound. The interaural differences also depend upon the distance of the sound source from the listener. Beyond a distance of 1 m, however, the effect of distance becomes negligible. Accordingly, in this section of the Compendium, data and discussion are limited mainly to sources in the "far field," that is, locations more than 1 m from the head.

Localization of sound frequencies below about 2,000 Hz is based mainly on interaural time differences and above 4,000 Hz mainly on interaural intensity differences. Localization is poorest at the middle frequencies (2,000 - 4,000 Hz), which suggests that neither binaural cue works well in the transition region. Indeed, some interaural time differences are unambiguous only up to about 1,500 Hz and interaural intensity differences begin to be substantial starting at about 3,000 or 4,000 Hz.

For a periodic sound, two interaural temporal cues are possible. One cue is related to the time of arrival of the sound or, more generally, to the sound's envelope. The other cue is related to phase or fine structure, which refers to cycle-by-cycle changes. The sound reaches the ear nearer the sound source before it reaches the other ear farther away. It also leads in phase in the nearer ear. When the sound is a pure tone, the interaural phase difference is constant and persists as long as the tone continues. However, phase cues appear to be useful only when successive cycles of a tone are sufficiently far apart for the auditory nervous system to keep track of them separately. Experimental evidence shows that this limit lies between 1,000 and 2,000 Hz, close to 1,600 Hz. Phase cues are also limited by the effective aerial distance between the two ears for frequencies above 750 Hz. For these frequencies, after the first cycle of the sound wave, it is unclear to the listener which ear leads in phase, since the first cycle in the lagging ear begins prior to the second cycle in the leading ear, which it precedes by less than half a period. The exact frequency at which such phase ambiguity begins depends upon the azimuth of the sound source. As the sound source moves toward the midline, the binaural time difference decreases so that the ambiguity begins at a higher frequency. Cues based on time of arrival do not suffer from this ambiguity.

Natural sounds usually have fairly abrupt onsets, and may have additional abrupt changes later on in their envelopes; such onset and ongoing envelope delays may give rise to interaural time differences that serve as cues in localization. To separate envelope delay (also called transient disparity) from interaural intensity differences, it is necessary to present the sounds via earphones; to distinguish them from ongoing differences in the fine structure, it is necessary to use very brief stimuli such as clicks, to pit ongoing fine-structure differences against onset differences, or to use sounds with different frequency content at the two ears. Earphone measurements have shown that listeners can detect onset time differences of 100-200 μ sec for tone bursts at frequencies above 1,500 Hz where fine-structure cues are not usable (Ref. 6).

The duration of the onset and offset disparities between the two ears depends on how fast the sound comes on and goes off, and is generally referred to as the rise-fall time. Studies of the effect of rise time on localization suggest that for brief signals, rise times faster than about 100 msec do provide usable cues for sound localization, and these cues become determinant when rise time is very rapid (Ref. 4).

Head movements serve to enhance binaural cues. Rotating the head in the horizontal plane gives rise to a rate of change of the interaural time difference that specifies the azimuth of a stationary sound source. Such movement can also specify the elevation of the source. Listeners make use of these cues in judging the location of a stationary sound source. For head movements to be effective, however, the sound's duration must exceed 250-300 msec. At shorter durations the cues change too little to be perceptible.

Monaural Cues. Although interaural differences provide the major cues to the localization of sounds in the horizontal plane, monaural cues are also available and are particularly useful to persons with unilateral deafness and to normally hearing listeners for resolving front-back ambiguities. The pinnae, head shadow, and head movements are the primary sources of monaural cues.

Sound shadowing by the head, sound reflection by the shoulder, and the folds of the pinna and the ear canal modify the spectrum of a sound as it travels to the eardrum. These modifications depend on the sound's frequency content and azimuth and can serve as cues to sound localization. Movement of the head or of the sound source may render monaural cues as effective as binaural cues in localizing sound. For a moving sound source, the predominant monaural cue is loudness changes; a displacement of 15 deg in the position of a sound results in a 2- to 3-dB change in level at the eardrum at nearly all audible frequencies. For a sound coming from the side, spectral changes that cause changes in timbre can also play a role because, at frequencies below 2,000 Hz, the level is independent of azimuth, whereas at higher frequencies the level changes noticeably with frequency.

Monaural cues are especially important in the localization of sounds lying in the median plane (CRef. 2.810). Given the placement of the ears, interaural time and intensity differences are absent (except for those caused by head asymmetry and by differences between the left and right pinnae) when a sound source is located directly in front or in back of the listener. A change in the height of the sound source leaves these interaural differences equal to zero, ex-

cept for asymmetries in the head and pinnae. Despite the lack of interaural differences in the median plane, however, we are able to distinguish front from back for most sound sources, either by moving the head or through familiarity with the sound. Moving the head puts the sound source outside the median plane, and interaural differences become available. Familiar sounds can be distinguished owing to the differential effects of the pinna. For example, a wide-band signal will be softer and different in timbre when in back than in front. Listeners can also distinguish the vertical (up-down) position of a sound source. The basis for this discrimination appears to lie in physical differences imposed on the sound reaching the ears by the head and pinnae.

Distance of a sound source

The primary cue to distance is sound intensity, which decreases as the square of the distance of the sound source. However, for this cue to be usable the listener must be familiar with the sound. Research has shown that when other distance cues are excluded, intensity alone can be used to judge distance, but the perceived change in distance as intensity decreases is much smaller than would be expected from the rule that doubling the distance decreases the sound pressure level by 6 dB (Ref. 2).

Other cues to distance come from changes in the timbre of a broadband sound. Timbre changes for two reasons, one physical, the other psychophysical. Beyond some 15 m the differential attenuation by air of low and high audible frequencies becomes noticeable with the higher frequencies more strongly attenuated than the low so that the timbre becomes deeper. At the same time the intensity decreases and the contribution of low frequencies diminishes because the loudness of low frequencies decreases more rapidly with decreasing level than does that of high frequencies. Just how the physical and psychophysical effects interact must depend upon the absolute levels and the spectra of the sounds. Under most listening conditions, reverberation occurs, and it serves as an indication of the distance of the sound source. Like intensity and spectral cues, reverberation requires some familiarity with the environment.

General Methods

Current studies of localization generally present the sound stimulus by means of loudspeakers or earphones. When loudspeakers are used, the subject is usually tested inside anechoic chamber—a room specially constructed of sound-attenuating materials designed to minimize extraneous noises and reduce reverberation from wall surfaces. The use of earphones allows interaural time and intensity differences to be controlled more precisely and to be manipulated independently of one another. However, certain complementary monaural cues are missing with earphone presentation, and the sounds are heard inside the head. Sounds with no interaural differences are heard in the center of the head, while interaural time or intensity differences cause the sound to appear to the left or right of center. (It is possible, however, to present sounds via earphones that give rise to externalized images if the sounds are recorded via microphones inserted in real or artificial ears.)

Identification of the left-right position of a sound source within the head under earphone presentation is frequently

called *lateralization*, rather than localization. The latter term is generally reserved for the identification of spatial position for sounds coming from the original source or from loudspeakers. **Psychometric functions to pure tones** of various frequencies have been found to be similar for earphone and speaker presentation (Ref. 5) and discrimination of the position of wide-band noise is as good for earphone presentation as for actual sound sources in a sound field (Ref. 3).

Studies of localization may measure either the accuracy or the precision of localization. By accuracy is meant the margin within which a listener can identify the absolute direction of an external sound source or locus of a sound image inside the head. By precision is meant the error with which a listener judges a change in direction of a sound source or of the intracranial locus. Most studies of localization have been concerned with accuracy whereas most studies of lateralization have been concerned with precision, but some have measured sidedness or lateral position.

—Adapted from Ref. 7

Applications

Improving the fidelity of sound reproduction systems; selecting warning or other signals whose location must be discriminated by the listener.

Constraints

- Sounds with broadband spectra, which provide multiple cues to spatial position, can be localized more accurately than pure tones.
- Sound localization is influenced by signal duration (CRef. 2.811), signal frequency (CRef. 2.813), head position and the presence of a visual context (CRef. 2.815).
- Optimal sound localization depends on input from both ears and the relation between the inputs for left and right

ears; localization is less accurate when one ear is plugged or covered.

- There are individual differences in the accuracy and precision of sound localization.
- The spatial perception of multiple sounds in a natural environment is not adequately addressed by only considering auditory localization; pitch, tonality, loudness, volume, density, time relations, and relative significance of the sounds interplay in auditory spatial perception in a natural environment.

Key References

- | | | | |
|--|--|---|--|
| <p>1. Blauert, J. (1983). <i>Spatial hearing</i>. Cambridge, MA: MIT Press.</p> <p>2. Gardner, M. B. (1969). Distance estimation of 0° or apparent 0°-oriented speech in anechoic space. <i>Journal of the Acoustical Society of America</i>, 45, 47-53.</p> | <p>3. Jeffress, L. A., & Taylor, R. W. (1961). Lateralization versus localization. <i>Journal of the Acoustical Society of America</i>, 33, 482-483.</p> <p>4. Kunov, H., & Abel, S. M. (1981). Effect of rise/decay time on the lateralization of interaurally delayed 1-kHz tones. <i>Journal of the Acoustical Society of America</i>, 69, 769-773.</p> | <p>5. Molino, J. A. (1974). Psychophysical verification of predicted interaural differences in localizing distant sound sources. <i>Journal of the Acoustical Society of America</i>, 55, 139-147.</p> <p>6. Scharf, B., Florentine, M., & Meiselman, C. H. (1976). Critical band in auditory lateralization. <i>Sensory Process</i>, 1, 109-126.</p> | <p>7. Scharf, B., & Houtsma, A. (1986). Audition II: Loudness, pitch, localization, aural distortion, pathology. In K. R. Boff, L. Kaufman, & J. P. Thomas (Eds.), <i>Handbook of perception and human performance: Vol. 1. Sensory processes and perception</i>. New York: Wiley.</p> |
|--|--|---|--|

Cross References

- | | | | |
|---|---|--|---|
| <p>2.802 Effects of the body on a sound field;</p> <p>2.803 Interaural intensity differences;</p> <p>2.804 Discrimination of interaural intensity differences for pure tones;</p> <p>2.805 Interaural time differences;</p> | <p>2.806 Discrimination of interaural phase differences for pure tones;</p> <p>2.807 Lateralization of clicks with interaural time delay;</p> <p>2.808 Lateralization of amplitude-modulated tones with interaural time delay;</p> <p>2.809 Trading between interaural intensity differences and interaural</p> | <p>time differences in auditory lateralization;</p> <p>2.810 Localization in the median plane;</p> <p>2.811 Effect of stimulus duration on lateralization of pure tones and noise;</p> <p>2.812 Precision of localization (minimum audible angle);</p> | <p>2.813 Effect of frequency on the localization of pure tones;</p> <p>2.814 Effect of static head position on localization;</p> <p>2.815 Effect of visual and proprioceptive cues on localization;</p> <p>2.816 Localization in noise;</p> <p>2.817 Echo suppression in localization</p> |
|---|---|--|---|

Notes

2.802 Effects of the Body on a Sound Field

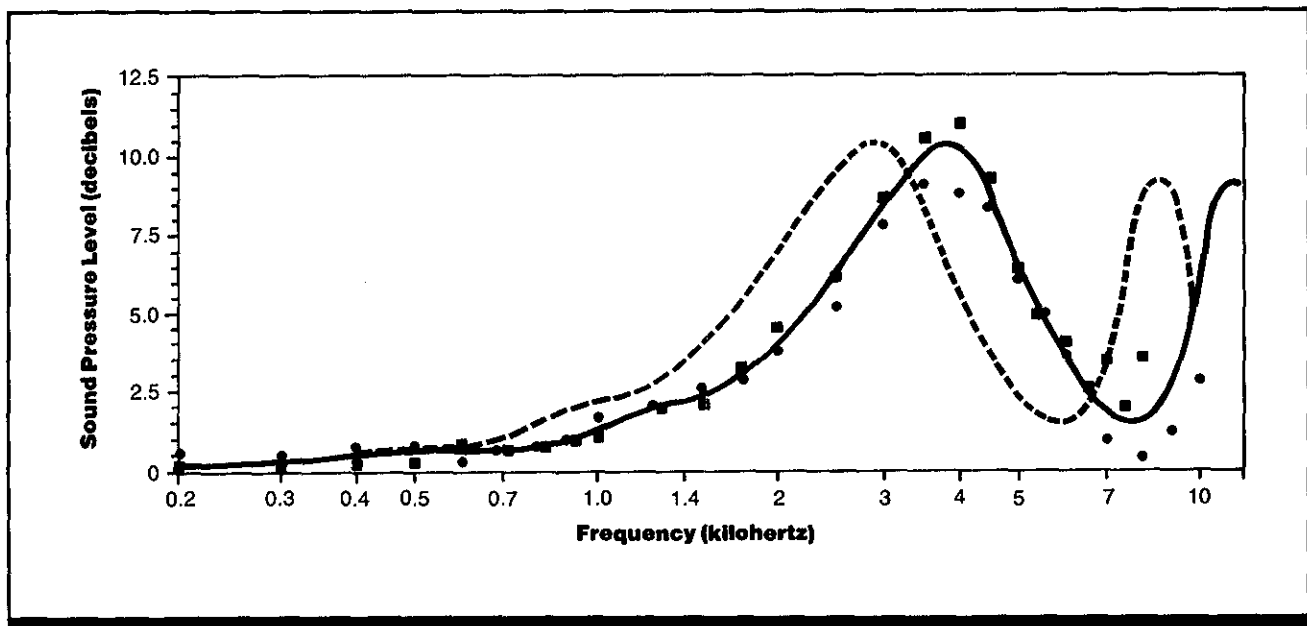

Figure 1. Average transfer functions for transforming sound pressure level at the outer ear to the equivalent SPL values at the eardrum. Curves show the difference (in dB) between SPL measurements made at the entrance to the ear canal (solid line) or the midconcha (dashed line) and SPL measurements made within 1 mm of the eardrum from various frequencies for one possible microphone position. The values for frequencies <8000 Hz are based on empirical data and those >8000 Hz are estimated from measurements on a human ear replica. The values for the functions will vary according to microphone position. (From Ref. 1)

Key Terms

Auditory localization; direction; frequency; intensity; sound pressure transfer function; sound shadow

General Description

The sound pressure level (SPL) of a sound source measured in a free field or in the outer ear is generally not the same as the SPL measured at the eardrum, due to reflections and modifications in the sound introduced by the subject's head, body, outer ear, etc. Measurements made using a microphone in the outer ear can be transformed to equivalent eardrum data using transfer functions similar to those shown in Fig. 1; however, the values for the applicable transfer function depend on the location of the microphone in the outer ear.

Data for tones and narrow-band noise obtained across a variety of studies employing measurements both at the eardrum and in the outer ear suggest that azimuth and frequency are both very important in determining shadowing

effects of the subject's body. The graphs in Fig. 2 plot the difference in SPL between measurements in a free field with the subject absent and measurements at the eardrum for point sources of various frequencies located to the front, side, and back (anterior, lateral, and posterior, respectively) of the head (0 deg is directly in front of the subject). The amount of difference in SPL varies with azimuth; the direction of the sound source has the greatest effect at frequencies >1000 Hz and toward the front and back, rather than the side. There is a peak for each curve at 2500 Hz; in other words, the presence of the subject's body results in a strong amplification of the signal when measured at the eardrum (versus measurements made in a free field). There is a strong attenuation at high frequencies (but the curves are less reliable at these frequencies).

Applications

Because modifications in the spectrum of a sound caused by the presence of the body vary with the azimuth of the sound source, such spectral changes serve as a cue to the spatial position of the sound; they are especially important in the localization of sources located in the median plane and localization using only one ear.

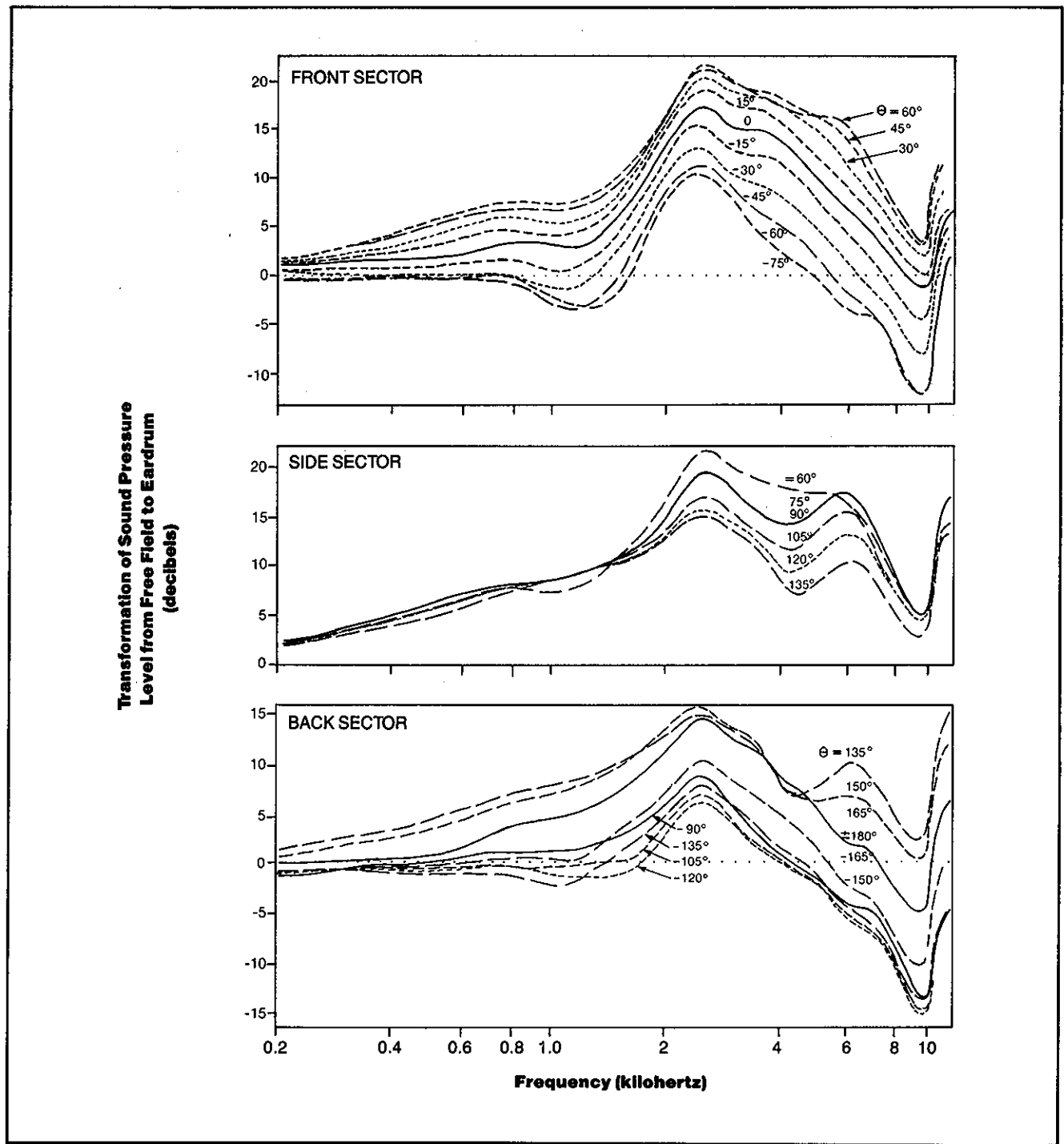

Figure 2. Difference in sound pressure level measured at eardrum and SPL measured in a free field (with subject absent) as a function of frequency and angle of incidence of point source to the ear. For ease of reading, curves are divided into three groups based on azimuth. (From Ref. 1)

Methods

Test Conditions

- Figure 2 summarizes studies from 12 laboratories using slightly different stimuli and techniques
- Direct sound pressure measurements made with subject seated in

anechoic chamber with point source of given frequency aimed at specific angle to ear and probe microphone in ear canal; indirect measurements made with microphone at external ear (not allowing for pressure changes in ear canal); sound pressure also measured with subject absent

- Angles of azimuth: 0 deg only (four studies); 0, 45, 90 deg (two studies); complete (four studies); and in between
- Pure tones and narrow-band noise with frequencies of 200-15,000 Hz
- Distance of point source from subject: 1-3.3 m

Experimental Procedure

- Independent variables: frequency of sound source, azimuth of source
- Dependent variable: difference between SPL measure with subject absent and SPL measured at outer ear or eardrum
- 3-20 subjects per study

Experimental Results

- Curves in Fig. 2 are visual fits to the average data after the outer-ear data were transformed to the equivalent eardrum data. Curves were smoothed where necessary using a criterion of consistency between adjacent curves. (For complete details, see Ref. 1.) The curves are less reliable for frequencies >8000 Hz because of a scarcity of data.
- Marked attenuation of SPL at the ear canal depends on frequency and azimuth of source.
- For frequencies <1500 Hz, azimuth has a relatively small effect.
- From 1500-2500 Hz there is a gain in SPL at all azimuths, which is most marked for sources at -75 to +60 deg (anterior sector curves).
- From 2500-10,000 Hz there is an attenuation of SPL,

with least change for sources from 60-135 deg (lateral sector curves).

- There is a steady increase in SPL at all azimuths for sources above 10,000 Hz.

Variability

Standard deviation for pure tones reported to be 1 dB for frequencies <500 Hz to ~5 dB above 500 Hz for transformations from free field to eardrum. The standard deviations are smaller when 1/3-octave bands of noise are used as stimuli.

Repeatability/Comparison with Other Studies

Data are somewhat consistent across studies from 5 countries over 40-yr period using 100 subjects, although there are some large disparities.

Constraints

- The average transfer functions in Fig. 1 will vary according to the position of the microphone in the outer ear.
- Reflected waves from shoulder may affect SPL, as can arm, leg, and head position.

- SPL can be affected by apparatus (e.g., subject's chair), hair, and clothing.
- There may be individual differences caused by body size.
- The 4:3 ratio for the curves in Fig. 1 has not been validated.

Key References

*1. Shaw, E. A. G. (1974). Transformation of sound pressure level from the free field to the eardrum in the horizontal plane. *Journal of the Acoustical Society of America*, 56, 1848-1861.

2. Wiener, F. M., & Ross, D. A. (1946). The pressure distribution in the auditory canal in a progressive sound field. *Journal of the Acoustical Society of America*, 18, 401-408.

Cross References

2.801 Sound localization;

Handbook of perception and human performance, Ch. 15, Sect. 3.2

Notes

2.803 Interaural Intensity Differences

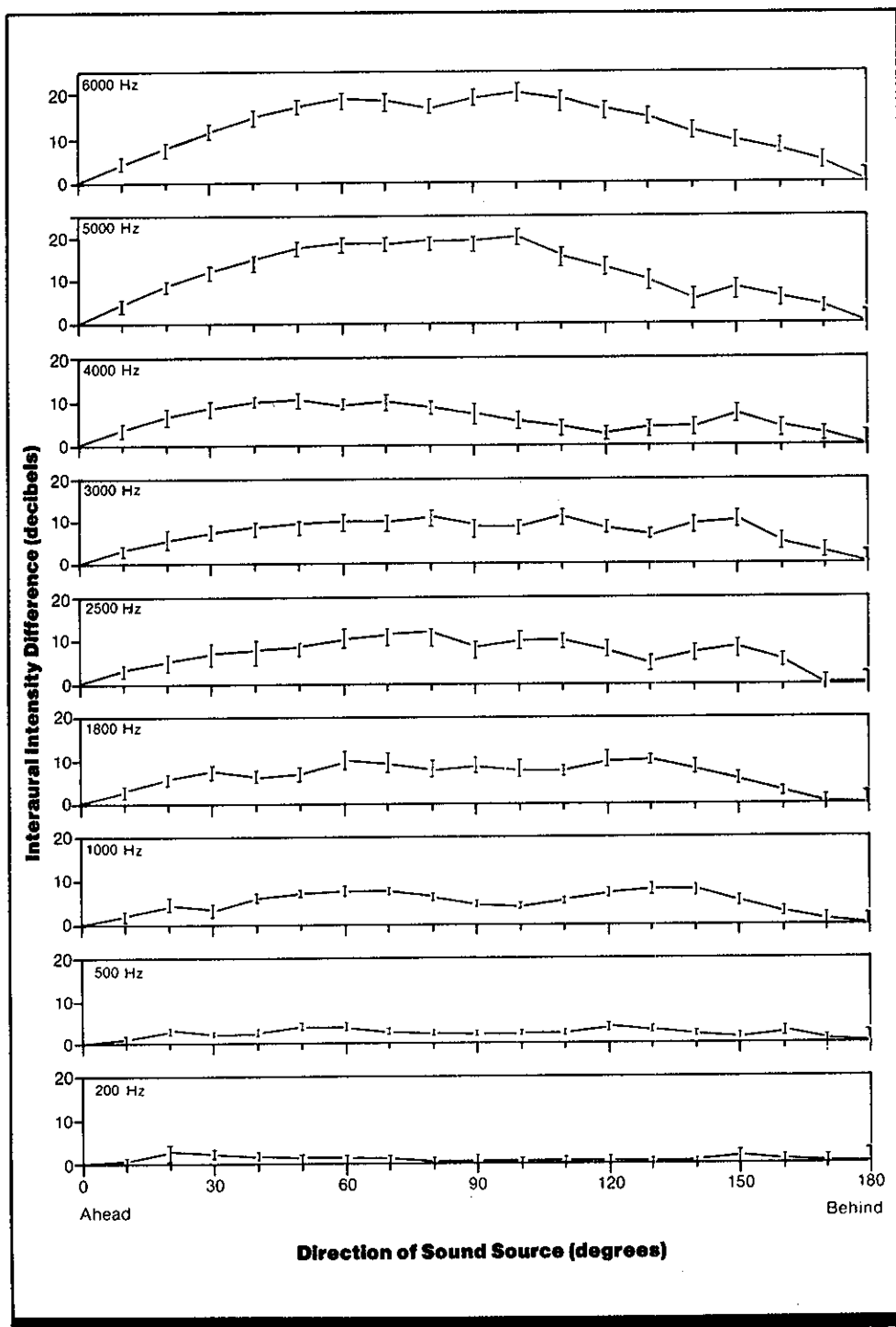

Figure 1. Interaural intensity differences as a function of frequency and direction of sound source. (From Ref. 2)

Key Terms

Auditory lateralization; auditory localization; diffraction; direction; frequency; interaural intensity differences; sound shadow; spatial localization

General Description

Because of sound shadowing by the head, the intensity of sound sources other than those located the the **medial plane** (straight ahead or behind) generally differ slightly at the left and right ears. This interaural intensity difference increases

with sound frequency and generally reaches a maximum for sound sources located at 60 and 120 deg from straight ahead. Sounds reaching the ears with different interaural intensities are perceived by the listener as coming from different spatial locations.

Applications

Interaural intensity differences are an important cue in the localization of high-frequency sounds (above ~1500-2000 Hz).

Methods

varied from 0-180 deg on both left and right sides of subject

Test Conditions

- Tones emitted from small loud-speaker mounted on 2-m boom
- Nine frequencies from 200-6000 Hz; source azimuth

• Intensity measured by probe microphone inserted short distance into one ear of subject; intensity level recorded continuously as sound source rotated slowly around subject

Experimental Procedure

- Independent variables: azimuth, frequency of tone
- Dependent variable: interaural intensity difference, obtained by

subtracting intensity level at one azimuth from that recorded at its mirror-image position (e.g., subtracting level measured at 330 deg from that at 30 deg)

- Two intensity measurements in each ear of each subject
- 5 subjects

Experimental Results

- For sounds located off the medial plane, the difference in intensity of a tone at the left and right ears generally increases with frequency.
- For a tone of a given frequency, intensity difference varies with azimuth position and usually reaches a maximum between 60 and 120 deg from straight ahead.
- Maximum interaural intensity difference occurs at different azimuth positions for different frequencies.

Variability

Vertical bars in Fig. 1 represent ± 2 standard errors of the means.

Repeatability/Comparison with Other Studies

Changes in the interaural intensity difference with source azimuth and frequency are similar to those reported in earlier studies (Refs. 3, 4).

Constraints

- Sound level readings, particularly at high frequencies, can be affected by the depth of placement of the probe microphone into the ear canal (Ref. 4).

- Real sounds are almost never pure tones but are mixtures of many frequencies.
- Interaural intensity differences, by themselves, provide cues to the direction only of sound sources that do not lie in the median plane (CRef. 2.801).

Key References

1. Blauert, J. (1983). *Spatial hearing*. Cambridge, MA: MIT Press.

*2. Feddersen, W. E., Sandel, T. T., Teas, D. C., & Jeffress, L. A. (1957). Localization of high-frequency tones. *Journal of the Acoustical Society of America*, 29, 988-991.

3. Sivian, L. J., & White, S. D. (1933). Minimum audible sound fields. *Journal of the Acoustical Society of America*, 4, 288-321.

4. Wiener, F. M. (1947). On the diffraction of a progressive sound wave by the human head. *Journal of the Acoustical Society of America*, 19, 143-146.

Cross References

2.801 Sound localization;

2.802 Effects of the body on a sound field;

2.804 Discrimination of interaural intensity differences for pure tones;

2.810 Localization in the median plane;

Handbook of perception and human performance, Ch. 15, Sect. 3.2

2.804 Discrimination of Interaural Intensity Differences for Pure Tones

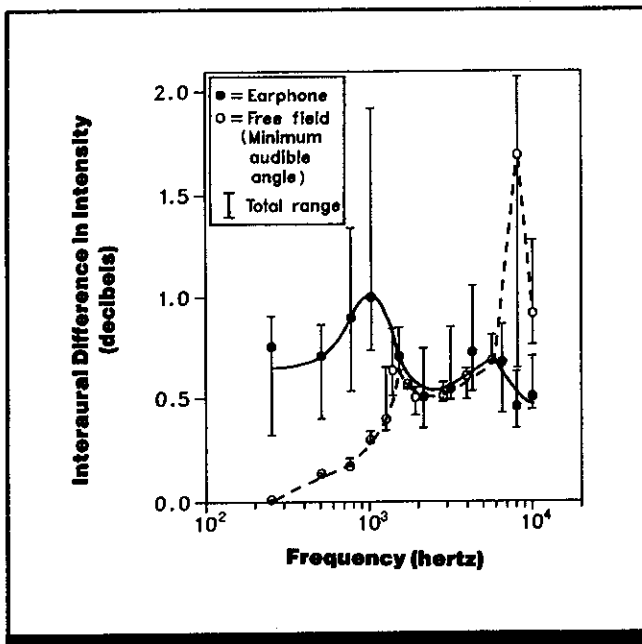

Figure 1. Just-noticeable interaural intensity differences for tone pulses as a function of frequency. Filled circles are intensity difference thresholds with earphone presentation. (Ref. 4). For comparison, open circles are intensity differences corresponding to the minimum audible angle (minimum discriminable difference in azimuth) at 0 deg with free-field presentation (CRef. 2.812). (From *Handbook of perception and human performance*, adapted from Ref. 4)

Key Terms

Auditory lateralization; auditory localization; frequency; interaural intensity differences; sound shadow; spatial localization

General Description

For sounds above 1500 Hz, the head provides an effective shadow, producing a difference in intensity between the left and right ears that can serve as a primary cue for auditory localization. For sounds presented via earphones, the just-noticeable difference (JND) in intensity between the ears at 50 dB above threshold is ~1 dB at 1000 Hz and less at greater or lesser frequencies (solid line, Fig. 1). This result is confirmed in other studies summarized in Table 1, which presents the JNDs for intensity as a function of

sensation level (level above threshold). At frequencies of 1500-6000 Hz, interaural intensity difference thresholds (solid line, Fig. 1) and free-field sound localization (just-noticeable deviation of a sound source from a location directly in front of subject, dashed line) are similar, which suggests that localization of frequencies in this range is based primarily on interaural intensity differences. These functions are not close at frequencies <1500 Hz; thus, other localization cues must be dominant for low-frequency sounds.

Applications

Interaural intensity differences are the primary cue for localization of sound sources above ~1500-2000 Hz.

Table 1. Just-noticeable interaural differences in intensity (ΔI , in decibels) for different frequencies and sensation levels. (Adapted from *Handbook of perception and human performance*)

Sensation level (decibels)	Frequency (hertz)				
	250 (Ref. 5)	500 (Ref. 3)	2000 (Ref. 5)	6000 (Ref. 5)	Broadband noise (Ref. 2)
5	—	—	—	—	2.2
10	—	1.9	—	—	—
20	1.5	1.5	1.0	1.1	1.5
30	0.9	—	0.8	0.9	—
50	0.6	1.0	0.5	0.6	1.6
70	—	0.8	—	—	2.8

Methods

Test Conditions

- Two tone pulses per trial, each 1 sec in duration with rise/fall time of 20 msec, presented dichotically in phase via earphones; 1 sec interval between tones
- Frequency of tones varied from 250-10,000 Hz

- Intensity of first (reference) tone 50 dB sensation level in one ear, intensity in other ear adjusted until tone appeared centered on head for each subject and this relative interaural intensity maintained throughout experiment
- Interaural intensity difference of sound (test) tone varied symmetrically around interaural intensity difference of first tone

cally around interaural intensity difference of first tone

Experimental Procedure

- Method of constant stimuli
- Independent variables: frequency of tones, interaural intensity difference of test tone
- Dependent variable: median interaural intensity difference thresh-

old, measured as the average of the 25% and 75% points on a straight-line psychometric function fitted to the data by the method of averages

- Subject's task: indicate whether second tone seemed to be to right or to left of the first (reference) tone
- 5 subjects with normal hearing and extensive practice

Experimental Results

- Threshold for interaural intensity difference is largest (sensitivity is lowest) for tone pulses of 1000 Hz; threshold is lower for frequencies above and below this value (Fig. 1, filled symbols, solid curve).
- For comparison, Fig. 1 also shows interaural differences in intensity corresponding to the minimum audible angle about the median plane (minimum detectable deviation for 0 deg, or straight ahead) for free-field presentation of tone pulses (unfilled symbols; CRef. 2.812 for methodological details; data converted from minimum audible angle to interaural intensity differences by Ref. 4 from measurements in Ref. 6).

- For frequencies of 1500-6000 Hz, the functions for intensity-difference thresholds with earphone presentation and minimum audible angle of actual sound sources coincide, indicating that intensity differences are used as the primary cue to sound localization for sounds within this frequency range.

Variability

- Variability is large enough that the form of the function is not well-defined, as shown by the vertical bars in Fig. 1, which indicate total range.

Constraints

- Only pure-tone sounds were used; results may differ for complex sounds.
- Minimum discriminable interaural intensity differences

may also vary with absolute intensity and duration of the sound stimulus.

- Results vary with direction of the sound source. There are no interaural intensity differences for sounds located in the median plane (plane bisecting body from front to back).

Key References

1. Blauert, J. (1983). *Spatial hearing: The psychophysics of human sound localization* (J. S. Allen, Trans.). Cambridge, MA: MIT Press.
2. Hall, J. L. (1964). Minimum detectable change in interaural time

or intensity difference for brief impulsive stimuli. *Journal of the Acoustical Society of America*, 36, 2411-2413.

3. Hershkowitz, R. M., & Durlach, N. I. (1969). Interaural time and amplitude JND's for a 500-Hz

tone. *Journal of the Acoustical Society of America*, 46, 1464-1467.

*4. Mills, A. W. (1960). Lateralization of high-frequency tones. *Journal of the Acoustical Society of America*, 32, 132-134.

5. Rowland, R. C., & Tobias, J. F. (1967). Interaural intensity differ-

ence limen. *Journal of Speech and Hearing Research*, 10, 745-756.

6. Sivian, L. J., & White, S. D. (1933). On minimum audible sound fields. *Journal of the Acoustical Society of America*, 5, 288-321.

Cross References

- 2.803 Interaural intensity differences;
- 2.809 Trading between interaural intensity differences and interaural time differences in auditory lateralization;

2.812 Precision of localization (minimum audible angle);

2.813 Effect of frequency on the localization of pure tones;

Handbook of perception and human performance, Ch. 15, Sect. 3.2

2.805 Interaural Time Differences

Key Terms

Auditory lateralization; auditory localization; direction; frequency; interaural time differences; spatial localization

General Description

Because of the location of the ears on each side of the head, all sounds except those on the median plane (directly in front or behind) reach the two ears at slightly different times. The ear closer to the sound source may receive the sound as much as 700 μsec sooner than the ear farther away.

Natural sounds usually have fairly abrupt onsets, and may have additional abrupt changes later on in their envelopes. Interaural delays in onset and envelope changes may give rise to interaural time differences that serve as cues in localizing the sound. For periodic sounds, an additional temporal cue is possible which is related to phase or fine structure (cycle-by-cycle changes). Not only does the sound reach the ear nearer the sound source before it reaches the other ear farther away, it also leads in phase in the nearer ear. These interaural time differences serve as a primary cue for the localization of sounds below ~ 1500 -2000 Hz. Sounds that differ in interaural time of arrival or interaural phase are perceived as coming from different directions relative to the listener.

The difference in arrival time between the two ears depends on the direction of the sound source and sound frequency. Figure 1 shows interaural difference in arrival time for tones of various frequencies and for clicks as a function of azimuth (angular distance of the sound source from straight ahead). The dashed curves are derived from a model in which the head is treated as a hard sphere with the ears replaced by two holes on opposite ends of a diameter. The lower dashed curve is from the formula $t = (r/s)(\theta + \sin \theta)$, where $r = 0.0875$ m (head radius) and $s = 344$ m/sec (speed of sound in air), and is based on simple geometric considerations. The upper curve is from the formula $t = (r/s)(3 \sin \theta)$, which represents the limiting case of diffraction theory as the frequency goes to zero (Ref. 1). As can be seen from the figure, interaural differences in time of arrival are greatest for sound sources directly to the side (90 deg from the midline). Interaural time delay tends to increase as frequency increases.

For low-frequency sounds, interaural delay causes the sound to be localized toward the leading ear. As the interaural time difference of a pure tone increases, perceived location shifts increasingly toward the leading ear. When the interaural delay reaches half the period of the tone, however, a single, fused sound image at a given location is no longer heard, but two separate images (or a diffuse, poorly localized image) are perceived. Results are similar for broadband and narrow-band noise, but fusion of the image may break down at different interaural time delays and in different ways from a pure tone (Ref. 2).

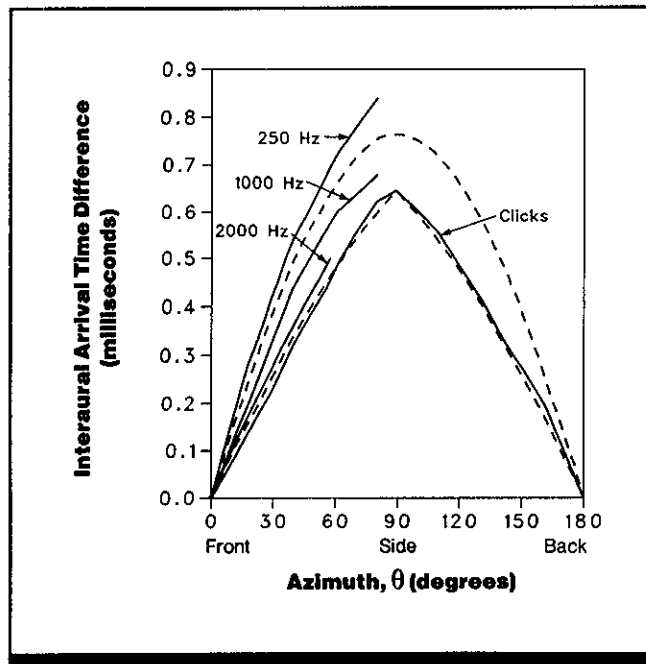

Figure 1. Differences in interaural arrival time as a function of azimuth position of sound source and sound type (clicks or tones). Dashed curves are derived from a formula that assumes a hard sphere with two holes for the head without diffraction (lower dashed curve) and with diffraction (upper dashed curve). Solid curves are measurements made on the heads of a number of subjects in various experiments. The click data are from Ref. 2, in which a probe microphone was placed at the entrance to the ear canal in each ear of 5 subjects and the time difference between the arrival of the click in each ear was measured. The data for pure tones are based on interaural phase measurements made on artificial heads by several studies summarized in Ref. 3. (From Ref. 2)

Discrimination of the elevation of a sound source and of front from back on the basis of interaural time differences is complicated by the so-called cones of confusion. The basis for the cone of confusion can be understood by first considering a sound source that moves along a hyperbola at the level of the two ears (Fig. 2a). The difference between the time of arrival at the left ear and at the right ear remains constant all along the hyperbola so that interaural time differences cannot distinguish back from front (or the distance of the sound source). If now the hyperbola is rotated, the surface of the resulting cone (Fig. 2b) defines a family of points all of which give rise to the same interaural time differences. Thus up-down as well as front-back discrimination cannot be based reliably on interaural time differences. However, the outer ear and head impose changes in the spectrum that differ for sounds coming from the front and back and from different elevations which can serve as cues in localizing these sounds.

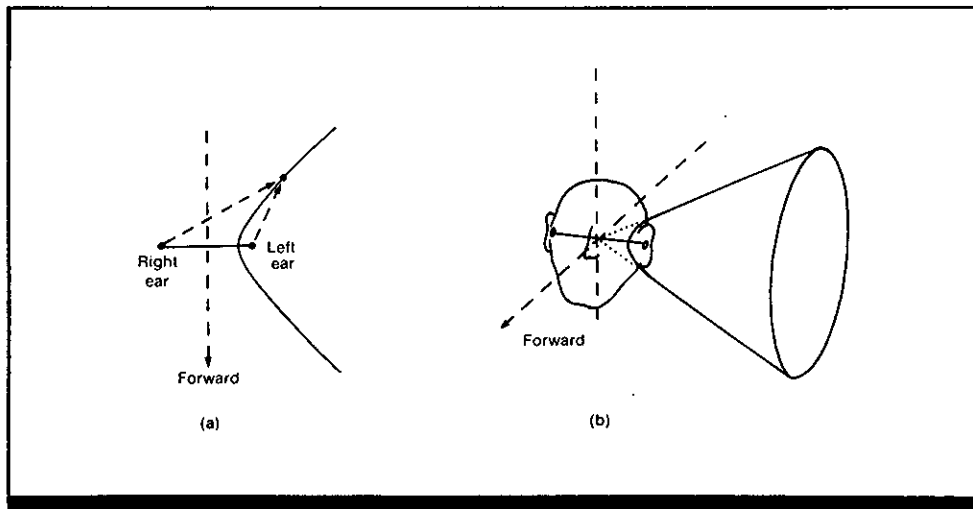

Figure 2. Positions of a sound source in space that yield the same interaural time differences. Panel (a) shows the hyperbola along which all sounds in the same plane give identical interaural time differences. On the basis of time delay alone a listener could not distinguish sound sources in front from those in back when they lie along the same hyperbola. Panel (b) is the same hyperbola rotated to yield a cone of confusion, so-called because all sounds on the cone's surface produce the same interaural time differences, which means that sound sources could be mislocated with respect to elevation as well as to front and back. (From Ref. 1)

Applications

Interaural time differences are the primary cue for the localization of sounds with frequencies below ~ 1500 - 2000 Hz.

Constraints

- Studies have only been done in anechoic chambers.
- Under some circumstances, interaural time differences can be compensated by differences in intensity between the two ears (CRef. 2.809).

Key References

1. Blauert, J. (1983). *Spatial hearing: The psychophysics of human sound localization*. Cambridge, MA: MIT Press.
2. Durlach, N. I., & Colburn, H. S. (1978). Binaural phenomena. In E. C. Carterette, & M. P. Friedman

(Eds.), *Handbook of perception IV: Hearing* (pp. 365-466). New York: Academic Press.

- *3. Feddersen, W. E., Sandel, T. T., Teas, D. C., & Jeffress, L. A. (1957). Localization of high-frequency tones. *Journal of the Acoustical Society of America*, 29, 988-991.

4. Scharf, B., & Houtsma, A. J. M. (1986). Audition II: Loudness, pitch, localization, aural distortion, pathology. In K. R. Boff, L. Kaufman, & J. P. Thomas (Eds.), *Handbook of perception and human performance: Vol. 1. Sensory processes and perception*. New York: Wiley.

- *5. Shaw, E. A. G. (1974). The external ear. In W. D. Keidel, & W. D. Neff (Eds.), *Handbook of sensory physiology* (Vol. VI/1, pp. 455-490). New York: Springer-Verlag.

Cross References

- 2.801 Sound localization;
- 2.806 Discrimination of interaural phase differences for pure tones;

2.807 Lateralization of clicks with interaural time delay;

2.809 Trading between interaural intensity differences and interaural

time differences in auditory lateralization;

2.812 Precision of localization (minimum audible angle)

2.806 Discrimination of Interaural Phase Differences for Pure Tones

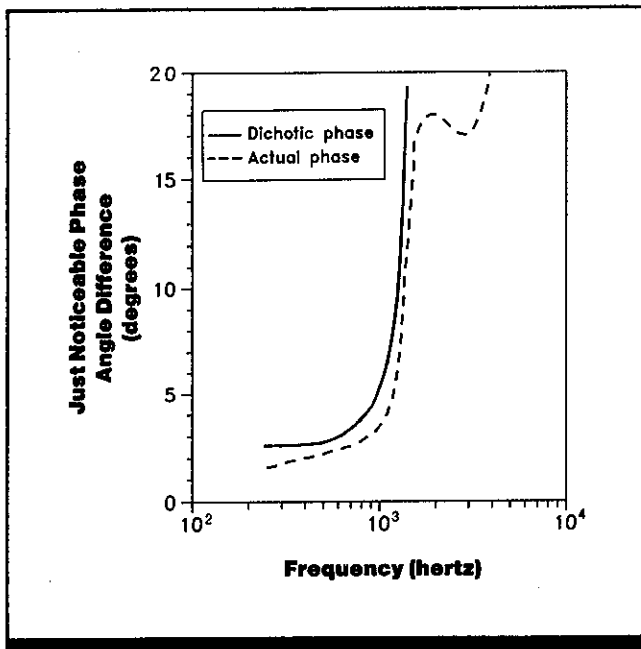

Figure 1. Just-noticeable interaural differences in phase of tone pulses as a function of frequency. Solid curve is phase difference thresholds with earphone presentation (Ref. 4). For comparison, dashed curve represents phase differences corresponding to the minimum audible angle (minimum discriminable difference in azimuth) at 0 deg with free-field presentation (CRef. 2.812). (From *Handbook of perception and human performance*, adapted from Ref. 3)

Key Terms

Auditory lateralization; auditory localization; frequency; interaural phase differences; interaural time differences; minimum audible angle; pure tones; spatial localization

General Description

Because of the separation of the ears in the head, sounds that are not in the median plane arrive at the left and right ears at slightly different times and lead in phase at the closer ear. With earphone presentation, listeners can detect phase differences between the two ears of 2-5 deg for pure-tone pulses of ~250-1000 Hz. The smallest detectable interaural

phase difference rises precipitously for tones greater than ~1500 Hz. At frequencies below ~1300 Hz, interaural phase difference thresholds for earphone presentation agree well with results for free-field localization of sound sources, indicating that, for this frequency range, localization is based primarily on interaural phase-difference cues.

Applications

Interaural phase differences are a primary cue for the localization of periodic sounds with frequencies below ~1500 Hz.

Methods

Test Conditions

- Pairs of auditory tones, identical in frequency, presented **binaurally** through headphones in- or out-of-phase; 50 msec rise and fall time for each tone; tone duration was ~1 sec with 1 sec between tones; duration between tone pairs was ~3 sec
- First tone always presented to **medial plane** of subject; second

tone presented out-of-phase; dichotic phase difference between first and second tones was randomly varied; 20 presentations at each phase difference

- Four sound frequency conditions (250, 500, 1000, and 1250 Hz)
- Sound pressure level ranged from 10-110 dB in 20-dB steps
- Subjects were asked to determine if second tone was presented to the right or left of the first tone

Experimental Procedure

- Combined paired comparison and two-alternative-forced choice (2AFC) methodologies
- Within-subjects, repeated measures design
- Independent variables: sound frequency, sound pressure level, and phase angle between first and second tones
- Dependent variables: phase angle difference corresponding to

the 75th percentile of the distribution of the subject's left-right judgments

- Subject's task: judge whether second tone originated from either the left or right of the first tone; guessing was required on trials where no phase difference was apparent to the subject
- 6 subjects; no other subject information given

Experimental Results

- Listeners can detect differences <5 deg in the phase of a tone pulse in the two ears for tone frequencies of ~ 1500 Hz and below. At higher frequencies, phase difference thresholds rise dramatically (Fig. 1, solid curve).
- For comparison, Fig. 1 also shows interaural differences in phase corresponding to the minimum audible angle about the median plane (minimum detectable deviation from 0 deg, or straight ahead) for free-field presentation of tone pulses (dashed curve; CRef. 2.812 for methodological details).
- For frequencies up to ~ 1300 Hz, the functions for phase-difference thresholds with earphone presentation and mini-

imum audible angle of actual sound sources coincide, indicating that phase differences are used as the primary cue to sound localization for sounds within this frequency range. This cue is most effective for frequencies below ~ 800 Hz.

- Interaural time difference is related to interaural phase difference by $\Delta t = \Delta\phi/360f$ where Δt = time difference in seconds, $\Delta\phi$ = phase angle difference in degrees, and f = frequency in Hz. There is a delay of 3 μ sec for each millimeter between source and far ear.

Variability

For earphone presentation, variability was high, with standard deviations of 50-75% at 500 Hz. Individual variability reported to diminish with practice.

Constraints

- Some aspects of the results do not generalize to clicks and may not generalize to other complex sound sources.
- Results may differ for different intensities of the sound source.
- Results vary depending on the azimuth of the sound source.

- There are no interaural phase differences for sources in the median plane (plane bisecting the body from back to front), except those introduced by individual anatomical asymmetries of the head or outer ear.
- Application of sound-localization results is complicated because materials and geometry of the natural environment, which is not a free field, cause differences from research done in acoustically free fields.

Key References

- | | | | |
|---|--|--|--|
| 1. Blauert, J. (1983). <i>Spatial Hearing: The psychophysics of human sound localization</i> (J. S. Allen, Trans.). Cambridge, MA: MIT Press. | 2. Mills, A. W. (1958). On the minimum audible angle. <i>Journal of the Acoustical Society of America</i> , 30, 237-246. | 3. Mills, A. W. (1960). Lateralization of high-frequency tones. <i>Journal of the Acoustical Society of America</i> , 32, 132-134. | *4. Zwislocki, J., & Feldman, R. S., Jr. (1956). Just noticeable differences in dichotic phase. <i>Journal of the Acoustical Society of America</i> , 28, 860-864. |
|---|--|--|--|

Cross References

- | | | |
|--|--|---|
| 2.801 Sound localization; | 2.808 Lateralization of amplitude-modulated tones with interaural time delay; | 2.812 Precision of localization (minimum audible angle); |
| 2.805 Interaural time differences; | 2.809 Trading between interaural intensity differences and interaural time differences in auditory lateralization; | 2.813 Effect of frequency on the localization of pure tones; |
| 2.807 Lateralization of clicks with interaural time delay; | | <i>Handbook of perception and human performance</i> , Ch. 15, Sect. 3.2 |

2.807 Lateralization of Clicks with Interaural Time Delay

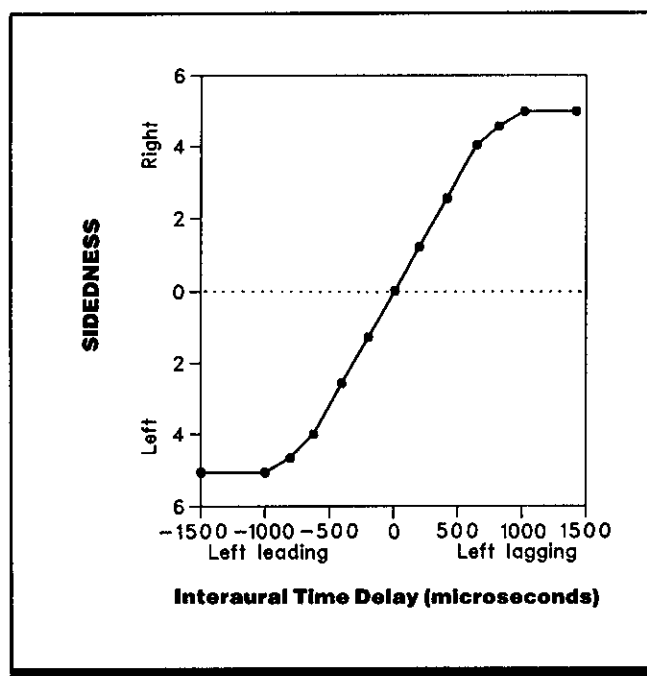

Figure 1. Perceived locus of a dichotic click as a function of difference in onset time at the two ears. Data are shown for one subject. 0 indicates that the click appeared located in the center of the head; 5, that the click appeared located at the left or right ear, as shown. (From Ref. 1)

Key Terms

Auditory lateralization; auditory localization; complex sound; interaural time differences; spatial localization

General Description

When intensity is held constant and identical acoustic signals are presented to the two ears such that one lags behind the other, a fused sound image is reported that is lateralized toward the leading ear. As interaural delay increases up to

~630 μsec , the apparent locus of the click is displaced increasingly away from the center of the head toward the leading ear. At delays $>630 \mu\text{sec}$, the click appears located at the leading ear. Repetitive clicks give rise to multiple acoustic images which can be lateralized independently.

Applications

Creating separate sound images by imposing different interaural delays enhances detectability. Testing of loudspeakers in a stereo system may be accomplished by examining the spread of loci for different frequencies of an auditory event.

Methods

- 40-50 dB above threshold
- Stimuli presented via earphones

Test Conditions

- 100- μsec binaural click in phase and at equal intensity in the two ears repeated every 6 msec at

Experimental Procedure

- Forced-choice identification of location of click along a ten-point scale

- Independent variable: interaural time delay
- Dependent variable: apparent location of click in relation to the two ears

- Subject's task: select point on scale (5 being one ear, -5 other, 0 center of head) corresponding to perceived location of the "dominant image" of the click
- 3-5 subjects, making at least 10 judgments per point

Experimental Results

- For clicks with interaural delays of ~ 630 μ sec or less, there is a linear change in perceived locus toward the leading ear as a function of delay.
- At longer interaural delays, the sound image is localized at the leading ear.
- Repetitive transient stimuli of the type used here produce binaural interaction tones that can be separately attended to and lateralized. Results shown in Fig. 1 are for the dominant acoustic image.

Variability

Data are shown for one subject; results for other subjects were not significantly different. No specific information on variability was given. Similar results have been reported for speech and noise stimuli.

Repeatability/Comparison with Other Studies

Reference 2 found comparable results for two-component tones.

Constraints

- Sound localization is influenced by the spectral content of the sound and sound duration (CRefs. 2.808, 2.811, 2.813).
 - There are individual differences in lateralization of stimuli with interaural time differences.
-

Key References

*1. Blauert, J. (1983). *Spatial hearing: The psychophysics of human sound localization* (J. S. Allen, Trans.). Cambridge, MA: MIT Press.

2. Toole, F. E., & Sayers, B. M. (1965). Lateralization judgments and the nature of binaural acoustic images. *Journal of the Acoustical Society of America*, 37, 319-329.

Cross References

2.801 Sound localization;

2.805 Interaural time differences;

2.806 Discrimination of interaural phase differences for pure tones;

2.808 Lateralization of amplitude-modulated tones with interaural time delay;

2.811 Effect of stimulus duration on lateralization of pure tones and noise;

2.813 Effect of frequency on the localization of pure tones;

Handbook of perception and human performance, Ch. 15, Sect. 3.2

2.808 Lateralization of Amplitude-Modulated Tones with Interaural Time Delay

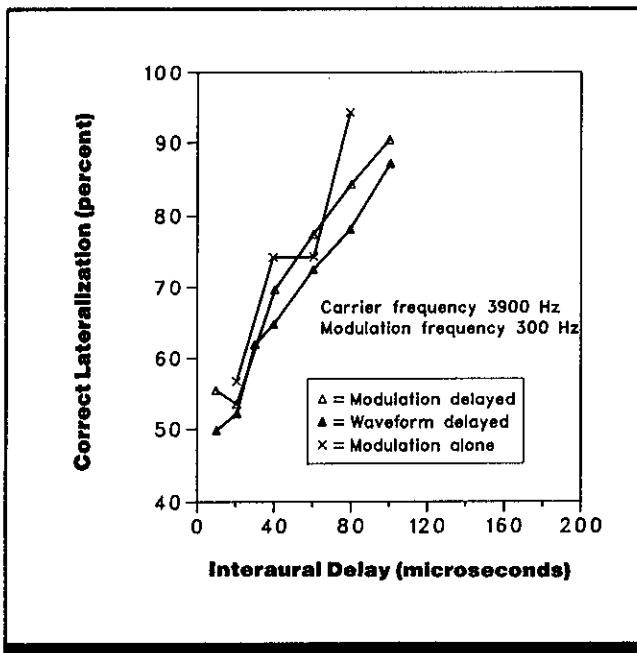

Figure 1. Lateralization accuracy as a function of interaural delay for a 300-Hz pure tone (modulation alone) and for a 3900-Hz carrier frequency modulated at 300 Hz when either the entire waveform or just the modulation (waveform envelope) was delayed in one ear relative to the other. Listeners had to discriminate when the signal to the right ear was delayed by identifying which of two interaurally delayed signals appeared to be located more to the left. (From Ref. 1)

Key Terms

Amplitude modulation; auditory lateralization; auditory localization; complex sound; frequency; interaural time differences; spatial localization

General Description

Sounds presented via earphones, with arrival delayed at one ear relative to the other, will seem to be located at different positions around the head depending on the amount of interaural time difference. In general, interaural time delays can be detected only for **pure tones** of frequencies below ~1500 Hz (CRefs. 2.805, 2.806). However, when a tone

burst of higher frequency (2100-7500 Hz) is amplitude modulated at a low frequency (50-300 Hz) and presented with interaural delay, **lateralization** (localization) of the modulated tone is as accurate as lateralization of an interaurally delayed low-frequency tone, regardless of whether the entire complex waveform or only the waveform envelope is delayed in one ear. Accuracy of lateralization increases as interaural difference in time of arrival increases.

Methods

Test Conditions

- 250-msec bursts of sinusoidal or complex waveforms turned on and off with linear rise and fall time of 50 msec; pure tone stimuli either 300 or 3600 Hz; complex waveforms produced by sinusoidal modulation of amplitude at 50-300 Hz to produce stimuli $s(t)$ of the form $s(t) = (1 + m \cos 2\pi f_m t) \cos 2\pi f_c t$, where t = time, m = depth of modulation (usually = 1), f_m = modulation frequency, and f_c = carrier frequency; identical or different carrier frequencies

of 2100, 3300, 3600, 3900, 4200, 4500, 4750, 4800, 5700, or 7500 Hz to the two ears; complex waveform presented at overall level of 50 dB sound pressure level (SPL)

- Pure tone, entire complex waveform, or waveform envelope only delayed in one ear relative to other by 0-260 msec; delayed waveform had the form $s(t - \Delta t) = 1 + m \cos[2\pi f_m (t - \Delta t)] \cos[2\pi f_c (t - \Delta t)]$, where Δt = interaural time delay in seconds; envelope delay varied independently of entire waveform; waveform with

envelope delay had form $s_{\Delta}(t) = \{1 + m \cos[2\pi f_m (t - \Delta t)]\} \cos 2\pi f_c t$

- Low-frequency (<600 Hz) masking noise constantly present at 50-dB SPL spectrum level
- Two intervals per trial; in first interval, stimulus in one ear delayed relative to stimulus in other ear and ear of delay reversed in second interval
- Signals presented binaurally over earphones operating in phase

Experimental Procedure

- Two alternative forced-choice procedure

- Independent variables: frequency of stimulus or carrier, type of stimulus (sinusoidal or complex), interaural time delay, envelope delay versus waveform delay, same versus different carrier to the two ears, depth of modulation, modulation frequency
- Dependent variable: percent correct lateralization judgments
- Subject's task: select the interval in which the right ear signal is delayed relative to the left, i.e., indicate in which interval the stimulus appeared further to the left
- 3 subjects with some practice

Experimental Results

- Lateralization of a 300-Hz pure tone with interaural delay is much better than lateralization of a 3900-Hz pure tone; performance is about chance for the 3900-Hz tone at all delays tested (<180 msec).
- For stimuli modulated in amplitude at 300 Hz, lateralization is significantly better than chance at carrier frequencies between 2100 and 5700 Hz. Performance is best at 3900 Hz; at higher and lower carrier frequencies, accuracy improves with increasing interaural delay at a slower rate than for 3900 Hz stimuli.
- Lateralization performance for amplitude-modulated stimuli is best with a modulation frequency of 300 Hz and decreases at lower and higher frequencies.
- Lateralization accuracy is essentially equivalent with interaural delay of a 300-Hz tone burst and with interaural delay of a 3900-Hz tone burst amplitude-modulated at 300 Hz, regardless of whether the entire complex waveform is delayed or only the waveform envelope is delayed (Fig. 1).

- Lateralization performance decreases as depth of modulation decreases.
- Lateralization of complex waveforms is poorer when the carrier frequencies differ between the ears than when they are the same.

Variability

Between-subject variability was high; for example, two subjects needed three times the delay needed by the third subject to reach the same accuracy level in some conditions.

Repeatability/Comparison with Other Studies

Reference 2 concluded that low-frequency information was necessary for lateralization. However, in the present study (Ref. 1), presence of a low-frequency mask eliminated the possibility that subjects were using the information from low-frequency difference tones (distortion products) rather than information from the amplitude modulation.

Constraints

- The detectability of interaural time differences may be influenced by stimulus duration (Ref. 2), especially at durations below 50-150 msec.

Key References

- *1. Henning, G. B. (1974). Detectability of interaural delay in high-frequency complex waveforms. *Journal of the Acoustical Society of America*, 55, 84-90.
2. Yost, W. A., Wightman, F. L., & Green, D. M. (1971). Lateralization of filtered clicks. *Journal of the Acoustical Society of America*, 50, 1526-1531.

Cross References

- | | | | |
|--|---|---|---|
| <p>2.801 Sound localization;</p> <p>2.805 Interaural time differences;</p> | <p>2.806 Discrimination of interaural phase differences for pure tones;</p> <p>2.807 Lateralization of clicks with interaural time delay;</p> | <p>2.809 Trading between interaural intensity differences and interaural time differences in auditory lateralization;</p> | <p>2.811 Effect of stimulus duration on lateralization of pure tones and noise;</p> <p><i>Handbook of perception and human performance</i>, Ch. 15, Sect. 3.2</p> |
|--|---|---|---|

2.809 Trading Between Interaural Intensity Differences and Interaural Time Differences in Auditory Lateralization

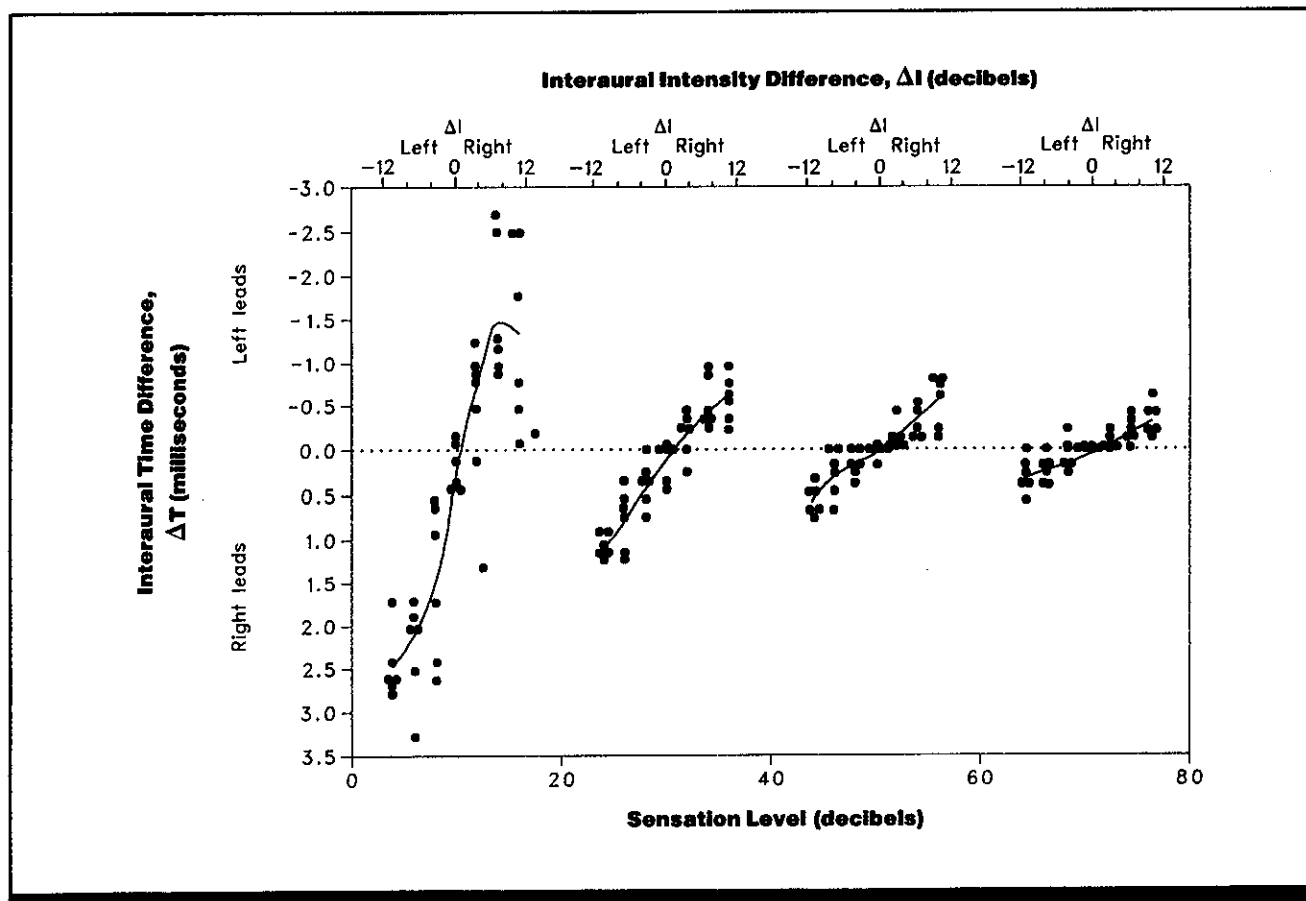

Figure 1. The interaural time difference (in msec) needed to offset an interaural intensity difference so that a noise click or sound pulse presented via earphones appears centered in the head. Individual data points should be read against top axis, which indicates difference in intensity between left and right ears (negative values indicate that stimulus in left ear was louder). The solid curves were obtained from third-degree polynomial fits to the data. (From Ref. 2)

Key Terms

Auditory lateralization; auditory localization; interaural intensity differences; interaural time differences; noise impulse; spatial localization; time-intensity tradeoff

General Description

When sound stimuli presented via earphones have different intensities or different arrival times at the two ears, the sound image will not appear centered in the head, but will appear located to the left or right of center. Interaural time differences and interaural intensity differences trade off against one another in determining where stimuli will be lateralized. Noise impulses or clicks that differ in intensity

in the two ears can be made to appear centered in the head if the stimulus to one ear is made to lead the stimulus to the other ear in time. The greater the intensity difference between the two ears, the greater the difference in interaural arrival time required to offset it. At higher overall intensity levels, smaller time differences are required to compensate for interaural differences in intensity.

Methods

Test Conditions

- Stimuli were 100- μ sec impulses generated by multivibrators through amplitude discriminators and delivered in correlated phase at the two ears, or 100- μ sec Gaussian noise pulses (clicks) uncorrelated at the two ears; both stimuli passed through 36 dB per octave 2000-Hz

high-pass filters; stimuli generated at a rate of 20 pulses per sec and presented via earphones

- Overall reference intensities of stimuli between 10 and 70 dB sensation level (SL; or, dB above threshold)
- Seven interaural intensity differences (-12 to $+12$ dB in 4-dB steps), controlled by differential attenuators
- Time of stimulus onset could be controlled in one ear to produce interaural differences in arrival time

Experimental Procedure

- Independent variables: interaural intensity difference, overall intensity level, type of stimulus (impulse or click)
- Dependent variable: interaural time difference necessary for stimulus to appear centered on head
- Subject's task: adjust interaural time difference until sound image appeared at center of head

- One series consisted of three trials at each of seven values of interaural intensity difference for each of seven levels of reference intensity; two series for each type of stimulus; data for the two series were combined for plotting and analysis
- 6 teenage female subjects screened for normal hearing; thresholds for impulses and clicks did not differ by >4 dB

Experimental Results

- A noise impulse or click, presented via earphones, which appears located away from the center of the head because of interaural differences in stimulus intensity can be shifted back to center by imposing a difference in the time of arrival of the stimuli at the two ears.
- The greater the interaural intensity difference, the greater the time difference required to offset it.
- The interaural time difference required to compensate for an interaural intensity difference decreases as overall intensity level increases. At 10 dB SL, a time difference of about 0.5 msec is required to offset an intensity difference of 1 dB, whereas only 0.1 msec time difference is required to compensate a 1-dB intensity difference at 70 dB SL.

Variability

Data for the 6 subjects were similar. Results did not vary from day to day.

Repeatability/Comparison with Other Studies

The time-intensity tradeoff values reported in the literature vary widely, with the value measured for low-frequency pure tones as much as 50 times less than the value for high-pass clicks reported here. Some of the differences are due to differences in the measurement ranges of the equipment used. Reference 2 found results for pure tones and clicks comparable to those presented here. Reference 2 reports that the slope of the time-intensity tradeoff differs for low-frequency and high-frequency impulsive stimuli and that changes with intensity are frequency-dependent.

Constraints

- "Small" monaural-threshold differences between a subject's ears were ignored.
- The artificial stimuli used in most time-intensity trading experiments give rise to a spatially broad sound image or to multiple sound images. Results depend on which image the listener attends to in making lateralization judgments.

- Methodological problems such as noted above and wide variations in time-intensity trade off values measured in different studies make it difficult to generalize these results.
- Under normal circumstances, interaural intensity differences and interaural time differences are perfectly correlated (i.e., the ear receiving the more intense sound also receives the sound first). Only under specialized conditions with earphone presentation can time differences and intensity differences be manipulated separately.

Key References

1. Blauert, J. (1983). *Spatial hearing*. Cambridge, MA: MIT Press.
- *2. David, E. E., Jr., Guttman, N., & van Bergeijk, W. A. (1959).

Binaural interaction of high-frequency complex stimuli. *Journal of the Acoustical Society of America*, 31, 774-782.

3. Harris, G. G. (1960). Binaural interactions of impulsive stimuli and pure tones. *Journal of the Acoustical Society of America*, 32, 685-692.

Cross References

- 2.801 Sound localization;
- 2.803 Interaural intensity differences;

- 2.804 Discrimination of interaural intensity differences for pure tones;
- 2.805 Interaural time differences;
- 2.806 Discrimination of interaural phase differences for pure tones;

- 2.807 Lateralization of clicks with interaural time delay;
- Handbook of perception and human performance*, Ch. 15, Sect. 3.2

2.810 Localization in the Median Plane

Key Terms

Auditory localization; frequency; high-pass noise; low-pass noise; median plane; narrow-band noise; spatial localization

General Description

Localizing sounds is largely dependent on differences in intensity and arrival time between the two ears. When the sound source is equidistant from the two ears, as when it falls in the median plane (the vertical plane bisecting the body from front to back, CRef. 5.701), these interaural cues are absent (except for those caused by individual asymmetries of the head and external ears), and localization of sound to the front, back, above, or below must be based on other information. Cues for median plane localization include head movements (which restore interaural differences), differential frequency filtering effects by the cavities of the ear, and familiarity with the sound source. When sounds are unfamiliar and head movements are not allowed, listeners judge a sound to be located in front, in back, or above on the median plane primarily on the basis of frequency. For accurate median-plane localization, sounds must be complex and must include frequency components above 7000 Hz. Occluding or bypassing the outer ear (by taping it down, covering it, or listening through a tube placed in the ear canal) confounds median plane localization as does narrow-band or low-pass filtering of noise with a cutoff < 8000 Hz. Occluding one ear switches the perceived locus to the other ear, rather than to the median plane, but this effect may be overcome in time.

Applications

Sound source localization is most accurate, both on and off the median plane, when head movements are allowed, outer ears are not occluded (no headphone or helmet), and sounds have high-frequency components. These conditions will likely enhance localization outside the median plane by providing more potent cues. Head movements to induce interaural differences and spectral effects provide the only cues for monaural and median plane localization.

Methods

Test Conditions

- Study 1 (Ref. 1): 1/3-octave noise pulses of 100-1000 msec at 30, 40, 50, or 60 dB sound pressure level (SPL) and from 125-16,000 Hz; signals presented from loudspeaker in front or in back of subject; subject seated in darkened anechoic room with head fixed
- Study 2 (Ref. 4): 600- or 4800-Hz tone bursts, low-pass filtered noise (< 2000 Hz) or high-pass filtered noise (> 2000 or > 8000 Hz) at 20 or 30 dB above threshold presented from 1 of 13

loudspeakers between -13 and 20 deg on the median plane with 0 deg = subject's eye level (Fig. 2; Ref. 4)

Experimental Procedure

- Independent variable: spectral composition of sound source
- Dependent variable: judged location of sound source
- Subject's task: while keeping head still, indicate apparent location of sound source
- 5-20 subjects per condition (Study 1); 6 subjects each hearing 80 presentations of each noise type (Study 2)

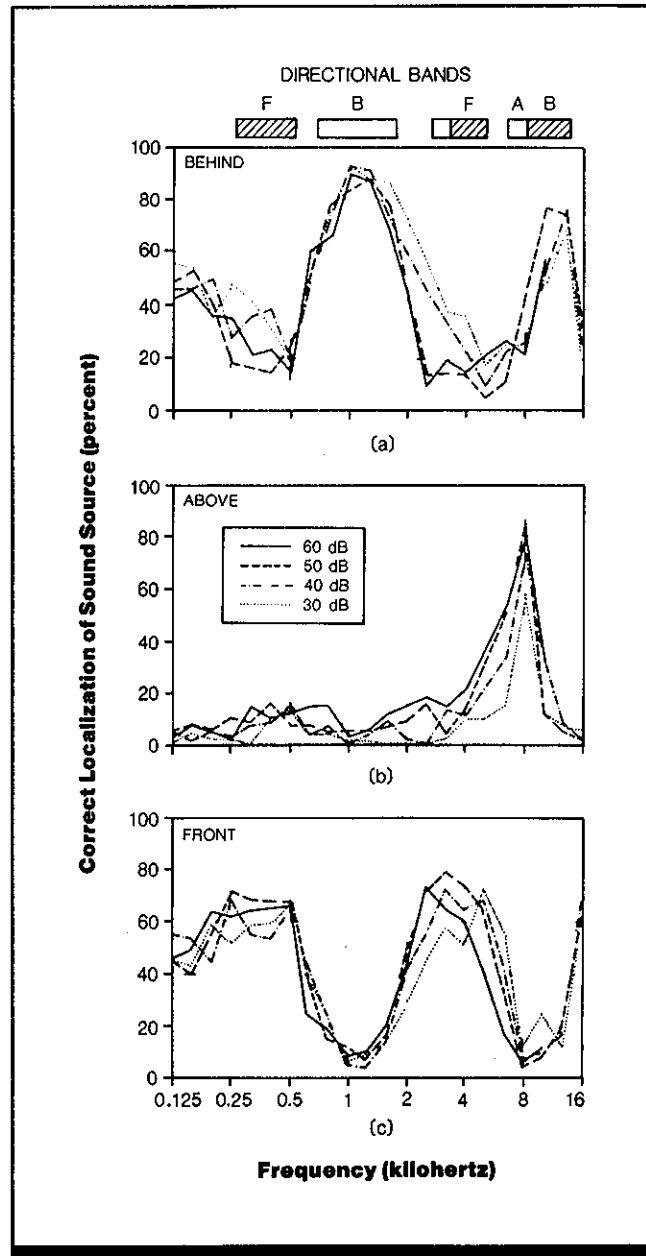

Figure 1. Judgments of direction in the median plane (Study 1). Percentage of judgments that a third-octave-band noise signal came from in front (c), above (b), or behind (a) plotted as a function of center frequency. The signal's sound pressure level varied as indicated. (Total percentage may exceed 100 at a given frequency because simultaneous judgments in two categories were allowed.) The bars at the top indicate the frequency ranges where each of the three categories of judgment predominates. Although the noises were presented half the time from the front speaker and half the time from the back, accuracy of judgments is not indicated. (From Ref. 1)

Experimental Results

- Judgments of the location of narrow-band noise in the median plane depend primarily on the center frequency of the noise (Fig. 1). "Front," "back," and "above" judgments tend to predominate at different frequency ranges, which have been termed "directional bands."
- Judgments of sound location on the median plane are not affected by the intensity of the sound (Fig. 1).
- Subjects make 20% errors in median-plane localization when both ears are open and 40% errors when one ear is plugged; error rate is 80% when both ears are plugged for wide-band noise signals (Ref. 1).
- The same general pattern of errors occurs for narrow-band signals, but there are increasingly more errors under each condition with successive lowering of the high-frequency cutoff of the noise or raising of the low-frequency cutoff to impinge on frequency transmission between 700 and 3500 Hz (Ref. 1).
- A subject's expectations of the locus of a sound source can cause reversals in apparent location in the median plane (Ref. 1).
- Localization of sounds in the median plane is much poorer for pure tones or noise bands that are low-pass filtered with a cutoff at 2000 Hz relative than for noise bands with high-frequency components (Fig. 2).
- Localization of noise bands abruptly improves when components between 7000 and 8000 Hz are added, but there is no additional improvement for frontal plane judgments when higher frequencies are added (Ref. 3).
- Median-plane localization is very poor when the outer ears are pressed against the head (Ref. 3).
- Placing into the ears tubes that are funneled backward causes the sound image to appear to be coming from behind the subject (Ref. 1).

Repeatability/Comparison with Other Studies

Reference 3 has also shown that subjects bias their judgments toward front or back depending on sound frequency when they are deprived of relevant information for median-plane localization. Reference 2 has substantiated the find-

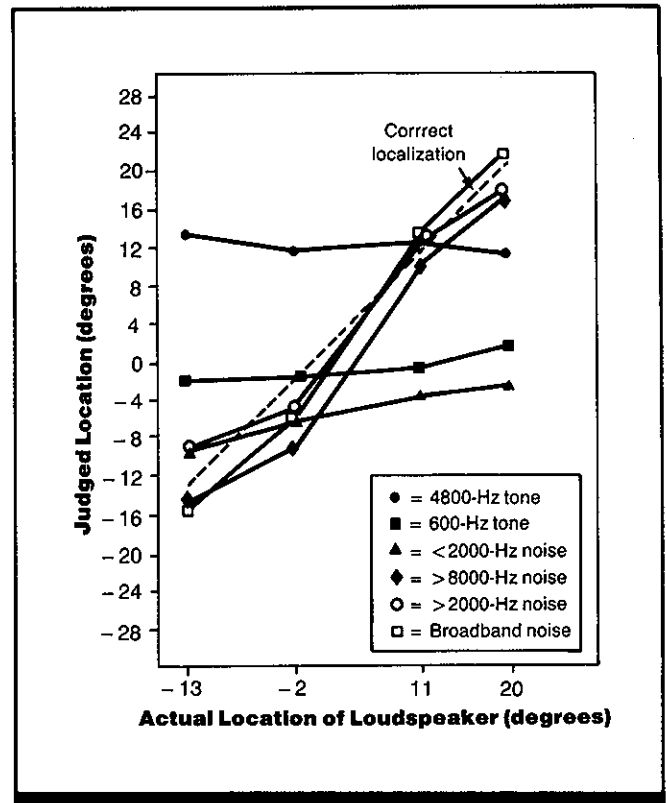

Figure 2. Judged location in the median plane as function of actual location and type of signal (Study 2). (From Ref. 4)

ings of Reference 3 regarding the contribution of higher frequencies to median-plane localization, but has also shown that some useful information is provided by frequencies of 500-4000 Hz.

Variability

No variability information was given.

Constraints

- Under real-world conditions, listeners can distinguish front from back for most sound sources by moving the head or by familiarity with the sound source (due to differential effects of the external ear).
- Heads are not always symmetric, and deviations from symmetry around median plane will affect measurements.

Key References

- *1. Blauert, J. (1983). *Spatial hearing: The psychophysics of human sound localization*. Cambridge, MA: MIT Press.
2. Gardner, M. B. (1973). Some monaural and binaural facets of median plane localization. *Journal of the Acoustical Society of America*, 54, 1489-1495.
3. Hebrank, J., & Wright, D. (1974). Spectral cues used in the localization of sound sources on the median plane. *Journal of the Acoustical Society of America*, 56, 1829-1834.
- *4. Roffler, S. K., & Butler, R. A. (1968). Factors that influence the localization of sound in the vertical plane. *Journal of the Acoustical Society of America*, 43, 1255-1259.

Cross References

- 2.201 Anatomy and physiology of the ear;
- 2.801 Sound localization;
- 2.813 Effect of frequency on the localization of pure tones;
- 5.701 Terminology used to describe head and body orientation;
- Handbook of perception and human performance*, Ch. 15, Sect. 3.3

2.811 Effect of Stimulus Duration on Lateralization of Pure Tones and Noise

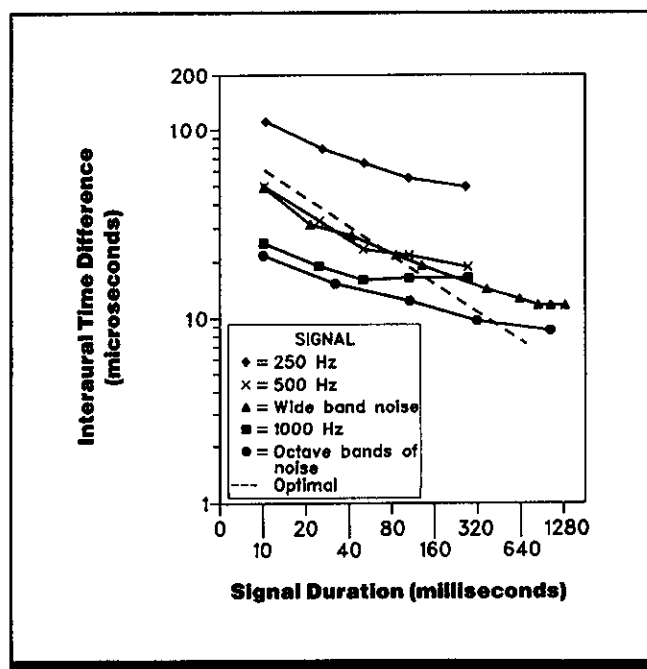

Figure 1. Minimum interaural time difference required to lateralize a signal toward the leading ear as a function of signal duration. Data are shown for pure tones (Ref. 3), octave-band noise (Ref. 2), and wide-band noise (Ref. 4). Dotted line shows decrease in interaural time difference thresholds expected if the auditory system were using all the temporal-disparity information available in the signal throughout the stimulus interval. (From Ref. 1)

Key Terms

Auditory lateralization; auditory localization; broadband noise; interaural time differences; narrow-band noise; spatial localization

General Description

Interaural time differences (time delay of the signal to one ear relative to the signal to the other ear) are cues for determining the location of a sound source. Threshold for detection of interaural time differences in stimuli presented via earphones decreases as signal duration increases, although the decrease is less than would be expected if listeners were

making optimal use of the available temporal information in the signal. As signal duration reaches some asymptotic value, threshold ceases to decrease, and signal duration no longer has any effect on the detectability of interaural time differences. The asymptotic value for the time-difference threshold varies greatly. For wide-band noise, the asymptote is ~700 msec; for a 1000-Hz pure tone, the asymptote is ~50 msec.

Methods

Test Conditions

- Octave-band noise with 500-Hz center frequency; stimulus durations of 10, 30, 100, 300, or 1000 msec; signal intensity of ~50 dB above threshold; earphone presentation; two stimulus intervals: stimulus to left ear delayed during one interval, stimulus to right ear delayed by equal amount during other interval;

interaural delays of 3-200 μ sec (Ref. 2)

- 50 dB sound pressure level (SPL) tone bursts of 250, 500, or 1000 Hz; tone durations of 10, 25, 50, 100, and 205 msec; rise-fall time of 2.5 msec; two stimulus intervals; signal to one ear led during either first or second interval; earphone presentation (Ref. 3)
- Noise bursts passed through 5000-Hz low-pass filter; 1.4 sec binaural reference burst with no

interaural delay followed after 0.1 sec by noise burst with 0-40 μ sec delay in either right or left ear; duration of second burst was 0.01-1.94 sec with interaural delays of 3-40 μ sec; 65 dB SPL for all but four shortest bursts; earphone presentation (Ref. 4)

Experimental Procedure

- Two interval forced-choice procedure (Refs. 2, 3); forced choice (Ref. 4)

- Independent variables: stimulus duration, interaural delay (Refs. 2, 3, 4), tone frequency (Ref. 3)
- Dependent variable: smallest interaural time difference at which stimulus could be accurately lateralized
- Subject's task: indicate whether the second stimulus appeared to the right or the left of the first stimulus
- 2 subjects (Ref. 2); 5 graduate student subjects (Ref. 4)

Experimental Results

- The minimum interaural time difference required to lateralize a stimulus toward the leading ear decreases with increasing signal duration for noise stimuli as well as for pure tones of various frequencies.
- The asymptotic value beyond which stimulus duration no

longer has an effect on interaural time difference thresholds varies widely. The asymptote is ~50 msec for a 1000-Hz tone and ~700 msec for wide-band noise.

- Interaural time difference thresholds for accurate lateralization increase as frequency decreases for pure tones of 250-1000 Hz.
-

Constraints

- There are individual differences in lateralization of stimuli with interaural time differences.
-

Key References

1. Hafter, E. R., Dye, R. H., Jr., & Gilkey, R. H. (1979). Lateralization of tonal signals which have neither onsets nor offsets. *Journal of the Acoustical Society of America*, 65, 471-477.

*2. Houtgast, T., & Plomp, R. (1968). Lateralization threshold of a signal in noise. *Journal of the Acoustical Society of America*, 44, 807-812.

*3. Ricard, G. L., & Hafter, E. R. (1973). Detection of interaural time differences in short duration low frequency tones. *Journal of the Acoustical Society of America*, 53, 335 (Abstract).

*4. Tobias, J. V., & Zerlin, S. (1959). Lateralization threshold as a function of stimulus duration. *Journal of the Acoustical Society of America*, 31, 1591-1594.

Cross References

2.801 Sound localization;

2.805 Interaural time differences;

2.806 Discrimination of interaural phase differences for pure tones;

Handbook of perception and human performance, Ch. 15, Sect. 3.2

2.812 Precision of Localization (Minimum Audible Angle)

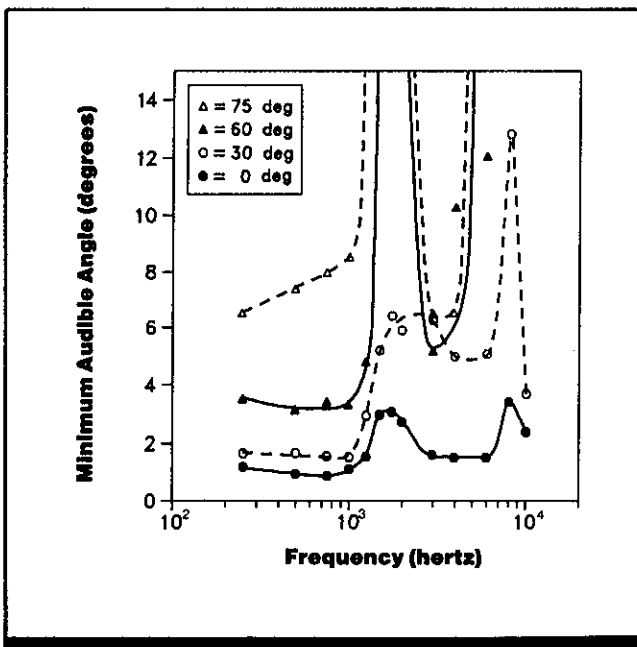

Figure 1. Minimum audible angle as a function of frequency of source tones and angle of source relative to (0-deg) reference point. Functions for 60 and 75 deg are shown in two parts because of extreme values for the maximums. (From Ref. 3, based on Ref. 2)

Key Terms

Auditory localization; direction; frequency; minimum audible angle; spatial localization

General Description

The minimum audible angle is the angle measured at the center of the head between lines drawn to two sound sources that have just noticeably different spatial positions. Minimum audible angle varies with location of the sound source about the subject's head; the smallest minimum audible

angle is straight in front and the largest is at 90 deg. For almost all locations, the minimum audible angle is smallest for tones between 250 and 1000 Hz, rises rapidly to a maximum thereafter, falls to a second (and higher) minimum between 3000 and 6000 Hz, and then rises to a second maximum at 8000 Hz.

Methods

Test Conditions

- Pairs of 1-sec pure tones, ~50 dB above threshold, with 70-msec rise-fall time, varying in frequency from 250-10,000 Hz, presented such that the first tone appeared in center (as determined

- by each subject) or 30, 45, 60, 75, or 90 deg to the subject's left, and the second tone a little to the left or right of the first; 1-sec interval between members of a pair; 3-sec interval between pairs
- Subject tested in anechoic chamber with chin locked in headrest and sound coming from source on a boom; for each location, chair

locked in place at prescribed angle to predetermined center (0 deg reference point)

Experimental Procedure

- Method of constant stimuli modified for forced-choice procedure
- Independent variables: frequency, azimuth relative to subjective center

- Dependent variable: minimum audible angle, as determined by 75% correct responses for direction of movement

- Subject's task: judge whether the second tone pulse was to the right or to the left of the first
- 3 male undergraduates with no significant hearing loss

Experimental Results

- Minimum audible angle is smallest for sources directly in front of the listener (0 deg) and increases markedly for sources at increasing angular displacements up to 90 deg.
- For all but the largest azimuths, minimum audible angle is smallest for frequencies from 250-1000 Hz.
- At all azimuths, localization is poorest for frequencies of

1500-2200 Hz and frequencies above ~5000 Hz, with good localization at frequencies between these values.

- Minimum audible angle at 90 deg is larger than the maximum of 40 deg that could be measured by the apparatus used, and results are not plotted for this azimuth.

Variability

Intersubject variability reported to diminish with practice.

Constraints

- Sound localization is influenced by sound frequency, the spectral content of the sound (complex sounds are localized more easily than pure tones), direction of the sound source, duration of the sound, head position, and the availability of a visual context (CRefs. 2.811, 2.813, 2.814, 2.815).

Key References

1. Blauert, J. (1983). *Spatial hearing*. Cambridge, MA: MIT Press.
*2. Mills, A. W. (1958). On the minimum audible angle. *Journal of the Acoustical Society of America*, 30, 237-246.

3. Mills, A. W. (1963). Auditory perception of spatial relations. *Proceedings of the International Congress on Technology and Blindness: Vol. II* (pp. 111-139). New York: American Foundation for the Blind.

Cross References

2.801 Sound localization;

2.804 Discrimination of interaural intensity differences for pure tones;

2.806 Discrimination of interaural phase differences for pure tones;

2.811 Effect of stimulus duration on lateralization of pure tones and noise;

2.815 Effect of visual and proprioceptive cues on localization;

Handbook of perception and human performance, Ch. 15, Sect. 3.2

2.813 Effect of Frequency on the Localization of Pure Tones

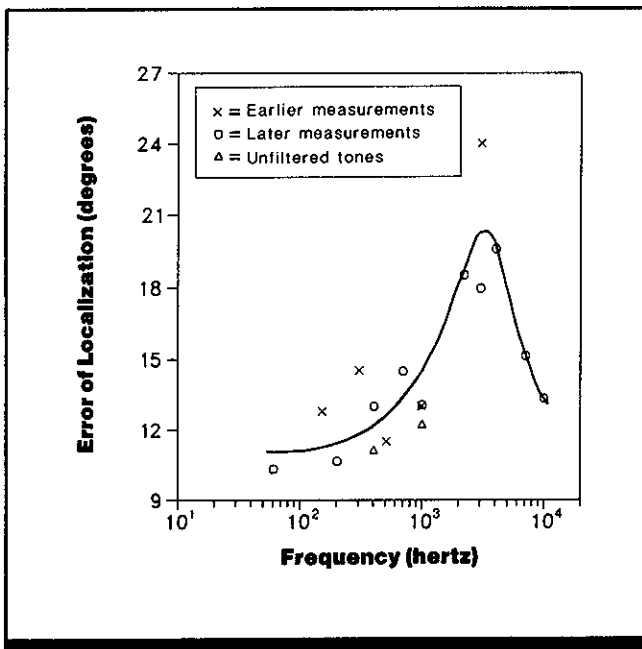

Figure 1. Error in localizing pure tones in the horizontal plane as a function of tone frequency. Earlier and later measurements were ~1 yr apart. Except as indicated, tones were filtered to reduce the level of the harmonics. (From Ref. 5)

Key Terms

Auditory localization; frequency; spatial localization

General Description

The ability to localize a **pure tone** in the horizontal plane varies with tone frequency. Localization is most accurate for low frequencies (<1000 Hz) and very high frequencies (10,000 Hz). Errors in localizing a sound are greatest for frequencies between 2000 and 4000 Hz.

Methods

Test Conditions

- Tone bursts presented from 9-cm loudspeaker situated at the end of a beam at ear level, 3.6 m from subject
- Tone bursts had smooth onsets and offsets; all but two tones filtered to reduce level of har-

monics; frequency varied from 60-10,000 Hz; tones of 400-4000 Hz presented at 50-60 phons; other frequencies at ~30 phons

- Subject seated in chair on top of roof to reduce sound reflections
- Tones presented at one of 13 positions on right side of subject only; positions were 15 deg apart, vary-

ing from 0 deg (directly in front) to 180 deg (directly behind)

Experimental Procedure

- Independent variables: frequency, position along horizontal plane
- Dependent variable: error of localization, defined as difference between reported azimuth and actual azimuth of sound source; front-

back confusions, although common, were not counted as errors

- Subject's task: indicate position of source of sound in horizontal plane
- Two series of measurements taken ~1 yr apart; for second series, ten judgments per subject at each azimuth position
- 2 subjects with extensive practice

Experimental Results

- Ability to localize tones under **free-field** conditions is greatest for low frequencies (<1000 Hz) and very high frequencies (10,000 Hz); localization is poorest for frequencies between 2000 and 4000 Hz, as indicated by the curve in Fig. 1.
- Errors in localization are smallest for tones located near the median plane (vertical plane bisecting the body from front to back).
- Front-back confusions are common at all frequencies, but occur nearly twice as often at frequencies below 2000 Hz.

Constraints

- The effect of frequency on sound localization may not necessarily hold under all environmental conditions. For example, in enclosed spaces reflections of sound from walls and other surfaces may alter the effect.
- Other variables, such as onset time (Ref. 1) and stimulus duration (CRef. 2.811) may also alter the effect of frequency on localization.
- In many types of localization tasks, front-back confusions would probably be interpreted as significant errors in

Key References

1. Blauert, J. (1983). *Spatial hearing*. Cambridge, MA: MIT Press.
2. Carterette, E. C., & Friedman, M. P. (Eds.). (1978). *Handbook of perception: Vol. 4. Hearing*. New York: Academic Press.

3. Kunov, H., & Abel, S. M. (1981). Effect of rise/decay time on the lateralization of interaurally delayed 1-kHz tones. *Journal of the Acoustical Society of America*, 69, 769-773.

4. Sandel, T. T., Teas, D. C., Fedderson, W. E., & Jeffress, L. A. (1955). Localization of sound from single and paired sources. *Journal of the Acoustical Society of America*, 27, 842-852.

- *5. Stevens, S. S., & Newman, E. B. (1936). The localization of actual sources of sound. *American Journal of Psychology*, 48, 297-306.

Cross References

- 2.801 Sound localization;
2.811 Effect of stimulus duration on lateralization of pure tones and noise;

- 2.814 Effect of static head position on localization;
2.815 Effect of visual and proprioceptive cues on localization;
Handbook of perception and human performance, Ch. 15, Sect. 3.2

Variability

No information on variability was given.

Repeatability/Comparison with Other Studies

Changes in accuracy of localization with frequency have been generally confirmed in a more recent experiment in which sounds were presented in an **anechoic** chamber (Ref. 4).

localization. If these cases were included, the errors in localization would be much greater than indicated in Fig. 1, particularly at frequencies <2000 Hz.

- Data shown are for pure tones; localization errors are smaller with broadband spectra more typical of real-world sounds.
- Localization varies with azimuth of the sound source, head position, and the availability of a visual context (CRefs. 2.814, 2.815).

2.814 Effect of Static Head Position on Localization

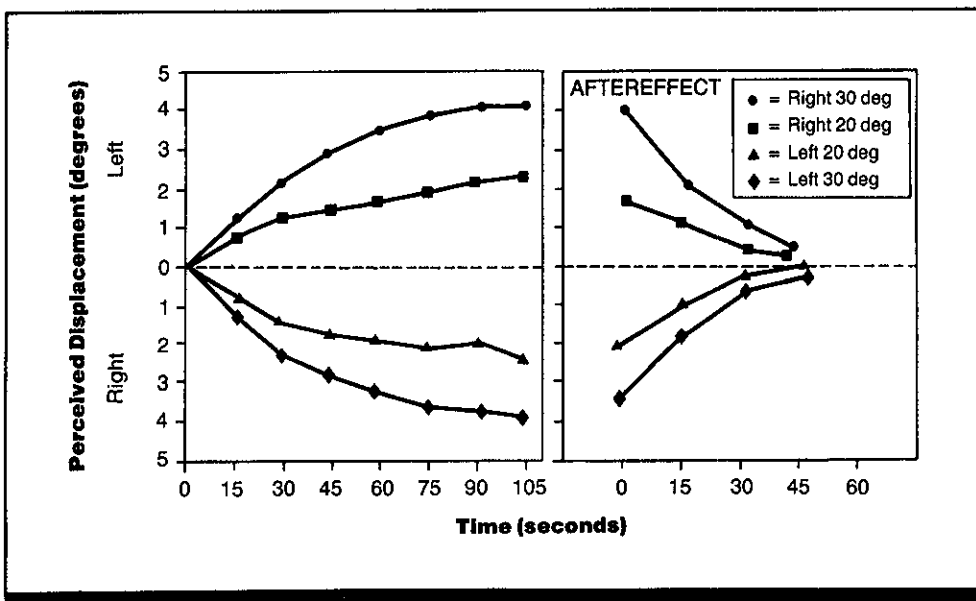

Figure 1. Changes in the localization of sound during and after head rotation. Vertical axis shows where a click source was presented in relation to the head when the click was heard as straight ahead of the subject. Left panel shows displacement in auditory localization as a function of time elapsed since head was rotated in the direction and by the amount indicated in the legend. Right panel shows displacement in auditory localization as a function of time elapsed since head returned to straight-ahead following 3 min of indicated head rotation. (From Ref. 2)

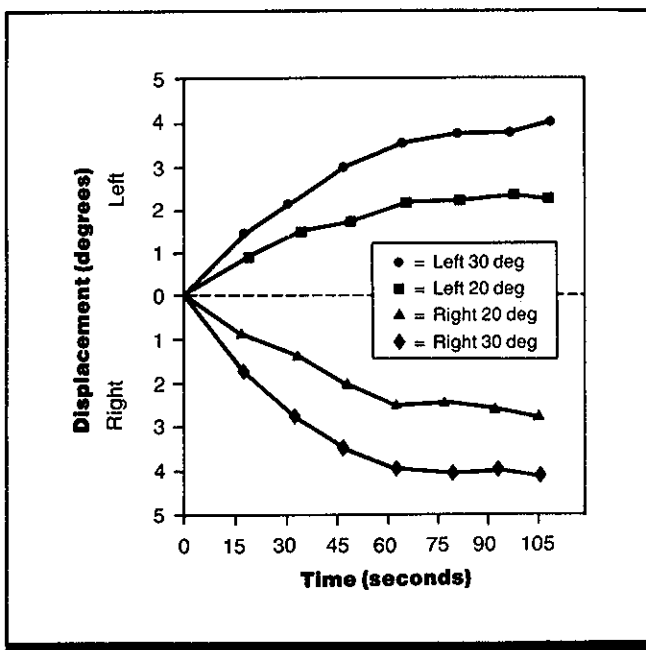

Figure 2. Development of postural adaptation as a function of head rotation and elapsed time. The vertical axis specifies the angle of the head to the torso upon return of the head to the perceived straight-ahead following head rotation of the amount and direction specified, held for the time indicated on the horizontal axis. (From Ref. 2)

Key Terms

Apparent straight-ahead; auditory localization; head position; head rotation; intersensory interactions; postural adaptation; spatial localization

General Description

When the head is rotated away from center (and vision is precluded), the apparent location of a sound source is displaced in the direction of the head rotation. When the head is returned to straight-ahead, the displacement in auditory localization remains for about 45 sec. After the head has

been held rotated for several seconds, the position to which the head is moved when it is felt to be centered is displaced from true straight-ahead in the same direction as the original rotation (known as *postural adaptation*). This postural adaptation is thought to be the cause of mislocalization of sounds during head rotation.

Methods**Test Conditions**

- Auditory localization: blindfolded subjects rotated their heads to positions, 30 and 20 deg left and right of center; head stabilized by bite-board; auditory stimulus was 1-Hz click at 40 dB above threshold; auditory localization of click measured before head rotation, for 3 min with head rotated and for

3 min after head returned to center position; clicks presented via boom-mounted microphone from 90 deg left to 90 deg right of midline

- Postural adaptation: head held rotated at 20 or 30 deg to left or right for 15-105 sec then returned by subject to perceived straight-ahead; experimenter noted any discrepancy and rotated subject's head to true straight-ahead

Experimental Procedure

- Independent variables: auditory localization (degree and direction of head rotation, duration head held in rotated or normal position), postural adaptation (duration head held in rotated position)
- Dependent variables: auditory localization (difference between perceived and actual straight-ahead location of clicks), postural adaptation (difference between perceived

and actual straight-ahead position of head)

- Subject's task: auditory localization (indicate direction in which sound source should be moved to seem directly in front of head), postural adaptation (return head to perceived straight-ahead position)
- 24 trained undergraduates; all subjects participated in postural adaptation condition, 12 subjects in auditory localization condition

Experimental Results

- When the head is rotated, the apparent auditory straight-ahead shifts in the direction of the head turn.
- Auditory displacement (mislocalization) develops over time, reaching a maximum at ~2 min.
- The auditory shift is greater for 30 deg than for 20 deg of head rotation.
- When the subject's head is returned to the objective straight-ahead after being held rotated for 3 min, auditory displacements occur which are comparable in magnitude to those that develop during 2 min of head rotation; these lo-

calization aftereffects decay within 45 sec after the head is returned to straight-ahead.

- When the subject's head is held rotated for a period, the perceived position of the head is shifted (the head comes to feel less rotated than it actually is). The perceived shifts in head position closely match the shifts in auditory localization during head rotation. This indicates that the displacement in perceived location of a sound source is due to changes in the felt position of the head.

Variability

No information on variability was presented.

Constraints

- Auditory localization errors and misperceptions of head position occur only when subjects are blindfolded or vision is otherwise precluded (Ref. 2).
- Sound localization is influenced by sound frequency, the

spectral content of the sound (complex sounds are localized more easily than pure tones), direction of the sound source, duration of the sound, and the availability of a visual context (CRefs. 2.811, 2.813, 2.815).

Key References

1. Lackner, J. R. (1973). The role of posture in adaptation to visual rearrangement. *Neuropsychologia*, 11, 33-44.

*2. Lackner, J. R. (1973). The role of posture in sound localization. *Quarterly Journal of Experimental Psychology*, 26, 235-251.

Cross References

2.801 Sound localization;
2.811 Effect of stimulus duration on lateralization of pure tones and noise;

2.813 Effect of frequency on the localization of pure tones;
2.815 Effect of visual and proprioceptive cues on localization;
Handbook of perception and human performance, Ch. 25, Sect. 2.3; Ch. 15, Sect. 3.

2.815 Effect of Visual and Proprioceptive Cues on Localization

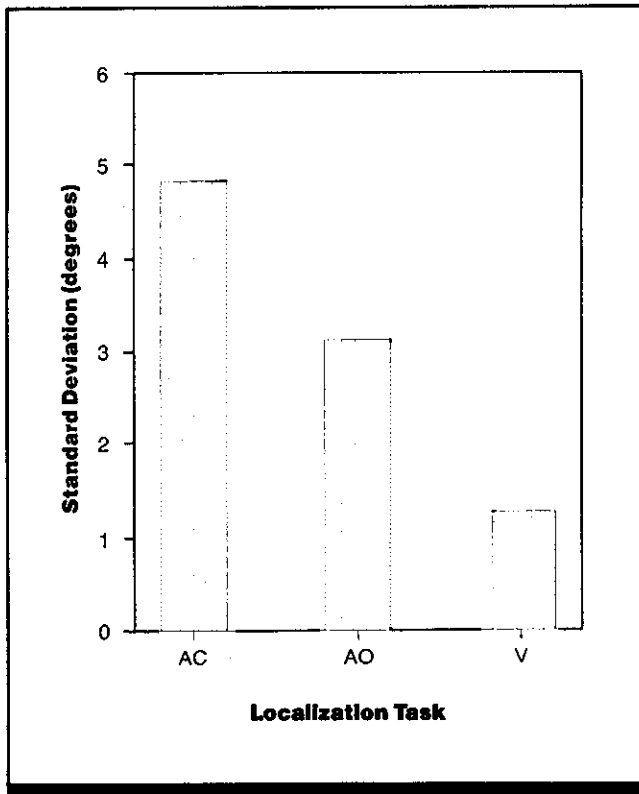

Figure 1. Accuracy in judging the spatial position of an auditory target with eyes closed (AC) or eyes open (AO), or the position of visual target (V). (Accuracy is measured as the standard deviation of subjects' responses in pointing to the target; smaller values indicate greater precision.) (From Ref. 3)

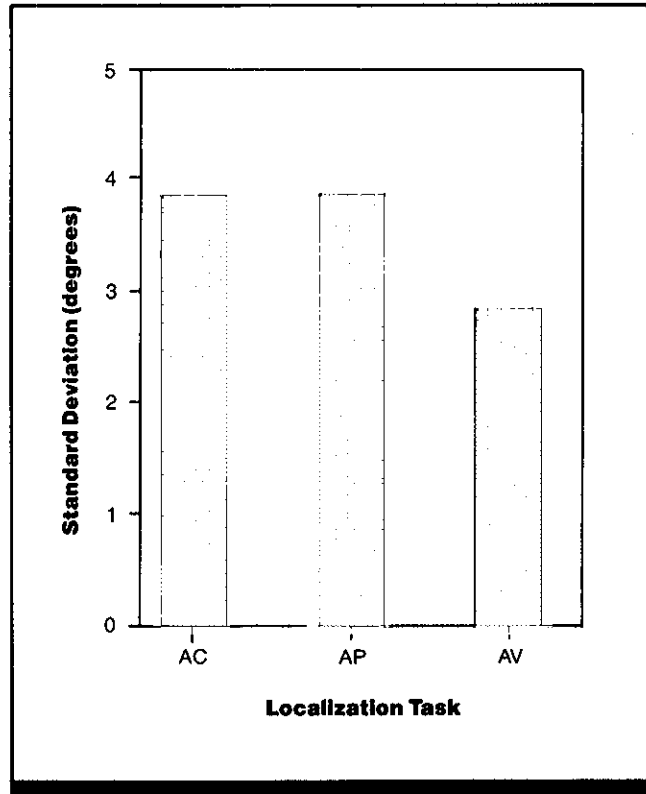

Figure 2. Accuracy in judging the spatial position of auditory targets with eyes closed (AC), with eyes closed and left arm and forefinger pointing straight ahead as proprioceptive reference (AP), or with eyes open in the presence of a reference light (AV). (Localization accuracy measured as the standard deviation of subjects' responses in pointing to the auditory target.) (From Ref. 3)

Key Terms

Auditory localization; spatial localization; visual facilitation

General Description

With head fixed in position, subjects can localize an unseen sound better with their eyes open than with their eyes closed. Having a visual reference point yields better performance than when the eyes are closed; having a proprioceptive reference point (i.e., left forefinger pointed straight ahead, eyes closed) does not have such a facilitative effect.

Methods

Test Conditions

- Auditory targets: series of clicks presented at two clicks per sec; sound source hidden from view
- Visual targets: points of light visible through cloth background used to conceal sound source
- Auditory and visual targets presented at 10, 15, 20 deg left and right of straight ahead, in horizontal plane with subject's chin

- For Exp. 1 (Fig. 1), conditions were: auditory targets with eyes closed, auditory targets with eyes open, visual targets
- For Exp. 2, conditions were: auditory targets alone with eyes closed, single reference light placed straight ahead at 20.3 cm (8 in.) above plane of auditory targets and simultaneously presented with onset of series of clicks (visual reference condition), or auditory targets with eyes closed and subject's left forefinger placed on

marker directly in front of subject (proprioceptive reference condition)

- Head steadied in chinrest; subject's right hand (used to point at target) concealed by shelf

Experimental Procedure

- Independent variables: target position in horizontal plane, type of target presentation (visual only, auditory with eyes closed, auditory with eyes open for Exp. 1; auditory with eyes closed, auditory with

proprioceptive reference, auditory with visual reference for Exp. 2)

- Dependent variable: localization accuracy, measured as standard deviation of pointing responses to targets at different positions
- Subject's task: point at location of auditory or visual target with concealed right forefinger
- 18 subjects, college students with some practice in Exp. 1 (18 second-graders and 18 sixth-graders also tested but results not reported here), 18 college students in Exp. 2

Experimental Results

- Locating an auditory target with eyes closed is much less precise than locating a visual target ($p < 0.01$).
- Auditory localization is more precise when eyes are open in a lighted environment than when eyes are closed ($p < 0.02$).
- Presence of a proprioceptive reference point does not facilitate auditory localization (when eyes are closed), but a visual reference point directly in front of subject does facilitate auditory localization ($p < 0.01$).

Variability

Variability as measured by standard deviation of responses is the dependent variable in this study. The mean of these standard deviations varied from < 2 to > 5 deg for different groups and tasks; individual standard deviations scores had a second deviation of 2-3 deg about the group task mean.

Constraints

- Sound localization is influenced by sound frequency, the spectral content of the sound (complex sounds are localized more easily than pure tones), direction of the sound source, duration of the sound, and head position. These factors must be considered in applying these data (CRefs. 2.811, 2.813, 2.814)

Key References

1. Jones, B., & Kabanoff, B. (1975). Eye movements in auditory space perception. *Perception & Psychophysics*, 17, 241-245.

2. Platt, B. B., & Warren, D. H. (1972). Auditory localization: The importance of eye movements and a textured visual environment. *Perception & Psychophysics*, 12, 245-248.

*3. Warren, D. H. (1970). Inter-modality interactions in spatial localization. *Cognitive Psychology*, 1, 114-133.

Cross References

2.801 Sound localization;
2.811 Effect of stimulus duration on lateralization of pure tones and noise;

2.813 Effect of frequency on the localization of pure tones;
2.814 Effect of static head position on localization;
Handbook of perception and human performance, Ch. 25, Sect. 2.3; Ch. 15, Sect. 3.

Repeatability/Comparison with Other Studies

A follow-up experiment (Ref. 3), using 6 subjects, showed that auditory localization is more accurate in a lighted environment than in the dark, but that performance is the same whether eyes are free to move or are fixated in a lighted environment, or opened or closed in a dark environment. Thus the critical condition for facilitation is that the environment be illuminated. Other experiments, however, have produced results suggesting that the critical element in the visual facilitation effect may be eye movements rather than the mere presence of light. In a lighted environment, if eye movements are not made, auditory localization is no more accurate than in the dark (Ref. 2), but a facilitation effect occurs when eye movements can be made freely in the direction of the sound (Ref. 1).

2.816 Localization in Noise

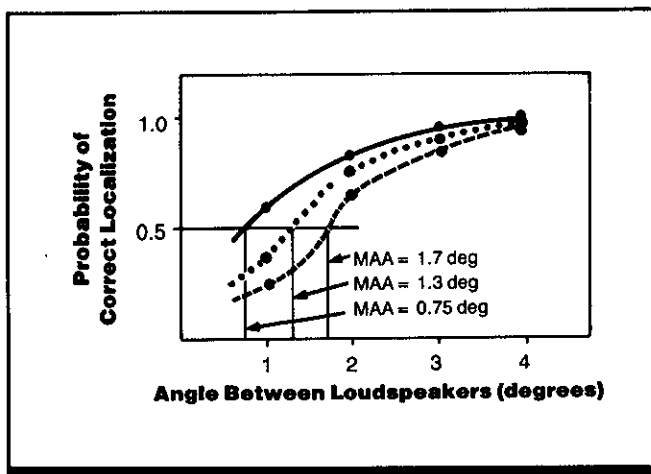

Figure 1. Localization of a 500-Hz tone presented in quiet or in background noise at a high signal-to-noise ratio. Vertical axis shows the probability of correctly localizing the tone as left or right of center at a given angular distance of the source from straight ahead. Data are shown for last 8 (solid line) and first 8 (dashed line) of 12 experimental series with background noise and 8 series with background noise (dotted line). MAA is the minimum audible angle, taken as the 50% point on each curve. Similar results are obtained for a 3000-Hz tone. (From Ref. 1)

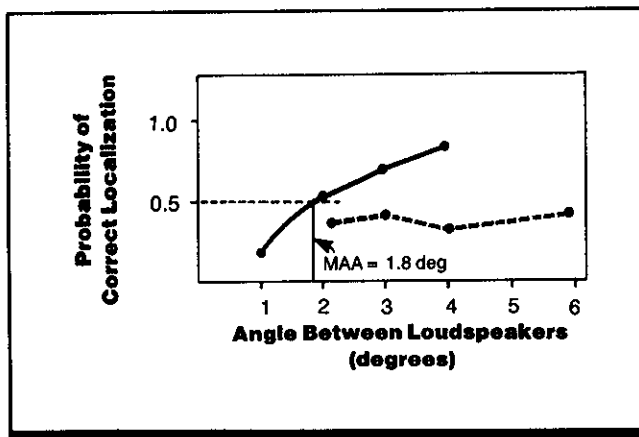

Figure 2. Localization of a 500-Hz (solid line) or 3000-Hz (dashed line) tone with background noise at a low signal-to-noise ratio. Vertical axis shows probability of correctly localizing the tone to left or right of center at a given angular distance of the sound source from straight ahead. MAA determined as in Fig. 1. (From Ref. 1)

Key Terms

Auditory localization; minimum audible angle; noise masking; spatial localization

General Description

For signals in the quiet, auditory localization is determined by interaural intensity and time differences as well as by modifications of sound spectrum imposed by the presence of the head and body and the external ears. It is generally easier to localize complex sounds, such as noise bands, than

to localize pure tones, presumably because more interaural difference cues are available. In auditory localization in the presence of noise, results replicate those obtained in the quiet. For signal-to-noise ratios >10-15 dB, noise has no influence on localization or on patterns of localization difficulty. At very low signal-to-noise ratios, higher frequency signals are detected before they can be localized.

Methods

Test Conditions

- Signals were pure tones of 500 and 3000 Hz and 1/3-octave white noise bands with center frequencies of 500 and 3150 Hz
- Background noise of 72 dB (A weighting scale) filtered white noise simulating traffic noise spectrum (0 dB at 63 Hz and rising to

~3 dB at 125 Hz, then gradually falling to -20 dB at 8000 Hz)

- 1-sec signal (75-msec rise-fall time) presented at 70 dB re 20 μ Pa or, during most trials, additional testing with signal at 3 dB over subject's masked threshold
- Stimuli presented over loudspeakers in anechoic chambers; reference loudspeaker in front of subject and other speakers at angles

of 1, 2, 3, 4, 6, and 8 deg right or left of reference speaker

Experimental Procedure

- Two-alternative forced-choice
- Independent variables: signal type (pure tone or noise band), signal frequency, presence or absence of background noise, signal location, signal-to-noise ratio, trial number

- Dependent variable: Minimum audible angle (at 0 deg azimuth), defined as the angular position of the stimulus that could be correctly localized with respect to the reference (straight ahead) on 50% of trials
- Subject's task: indicate whether signal was to right or left of center
- 3 male and 3 female subjects; ages 20-30, with normal hearing

Experimental Results

- At the high signal-to-noise ratio used (>10-15 dB), the presence of background noise has no effect on the ability to localize pure tones (Fig. 1).
- Localization of pure tones is poor at low signal-to-noise ratios (Fig. 2). A 3000-Hz signal presented in noise could be detected, but not localized, when the signal was only 3 dB above threshold.
- Noise bands are easier to localize than both pure tones in noise and pure tones in quiet. Minimum audible angle (smallest detectable angular difference in spatial position of a sound source) is 0.90 deg for noise with a center frequency of 3150 and 2.2 deg for a 300 Hz tone; there is less difference between minimum audible angle for a noise band

Constraints

- Localization in noise is affected by the frequency relations between signal and noise. Localization is poorer when signal and noise share the same **critical band** than when they occupy different bands.
- Localization is adversely affected if noise onset precedes

Key References

*1. Jacobsen, T. (1976). *Localization in noise* (Technical Report 10). Lyngby, Denmark: Technical University of Denmark Acoustics Laboratory.

2. Scharf, B., Canévet, G., Buus, S., & Marchioni, A. (1982). *Localization in noise by hearing impaired subjects*. Paper presented at the 16th International Congress of Audiology, Helsinki.

Cross References

2.801 Sound localization;
2.811 Effect of stimulus duration on lateralization of pure tones and noise;

2.812 Precision of localization (minimum audible angle);
2.813 Effect of frequency on the localization of pure tones;

centered on 500 Hz (0.75 deg) and for a 500 Hz tone (1.7-0.75 deg, depending on practice).

- Localization accuracy for stimuli at 1 and 2 deg from center improves with training (Fig. 1).

Variability

Significance of results was tested with sign test. Consistency across subjects was reported.

Repeatability/Comparisons with Other Studies

As frequency separation between signal and noise increases, localization thresholds improve less rapidly relative to detection thresholds for hearing-impaired subjects with sensory nerve damage than for subjects with normal hearing (Ref. 2).

signal onset by ~20 msec and signal and noise are close in frequency (Ref. 2).

- Sound localization is influenced by the spectral content of the sound, direction of the sound source, duration of the sound, head position, and the availability of a visual context (CRefs. 2.811, 2.813, 2.814, 2.815).

2.814 Effect of static head position on localization;

2.815 Effect of visual and proprioceptive cues on localization

2.817 Echo Suppression in Localization

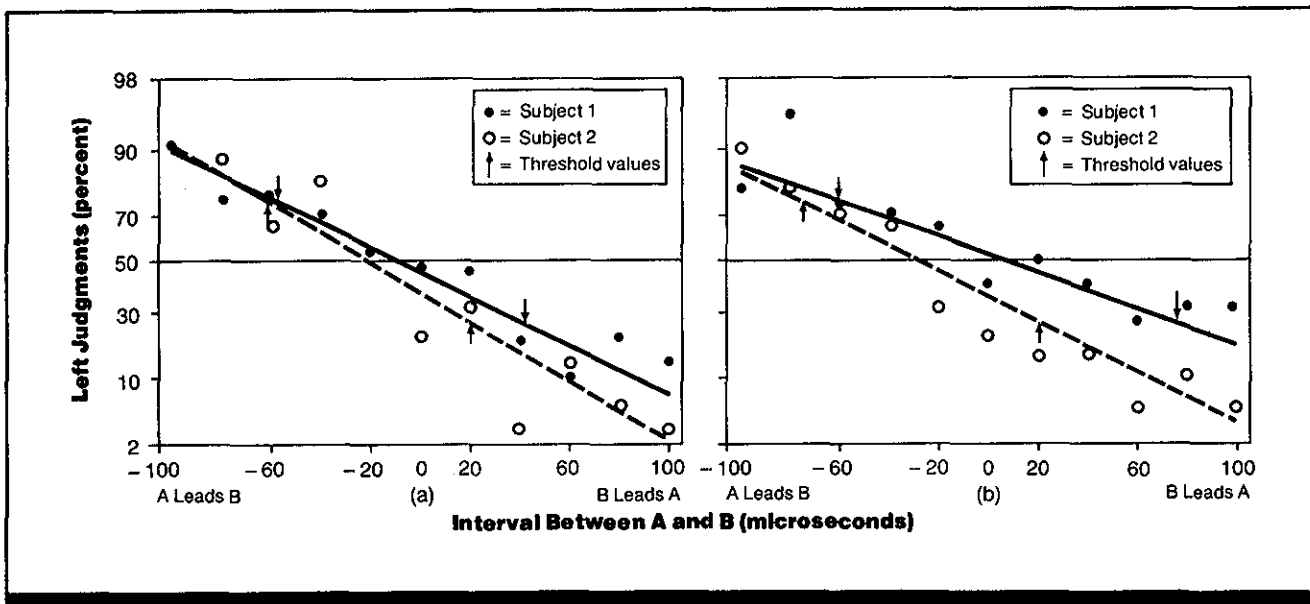

Figure 1. Localization of single and double click pairs. (a) Percentage of trials on which dichotic clicks A and B are localized to the left of center as a function of the interaural time delay between the clicks (Interval #1). (b) Percentage of "left" localizations when clicks A and B are followed after 2 msec by a second pair of clicks (C and D) presented simultaneously to the two ears, as a function of interaural time delay between A and B. The solid line at 50% indicates chance performance. Data are shown for two subjects (both had a slight constant error to the right). Arrows indicate the values of interaural delay between clicks A and B at which the stimulus was judged to the left of center or to the right of center on 75% of trials. (From Ref. 2)

Key Terms

Auditory localization; echo; echo suppression; interaural time differences; precedence effect; spatial localization

General Description

In laboratory settings the perceived location of a sound source may be manipulated by controlling interaural time and intensity differences. In the natural environment, interaural time and intensity effects are more complex because of echoes. In a room, a sound on the right reaches the right ear first, arrives at the left ear later (slightly attenuated because of head shadowing), bounces off the left wall, echoes into the left ear (slightly attenuated compared to the original wave), and finally, echoes into the right ear with greater attenuation.

Given the appropriate timing and intensity relations, a sound and its echoes are not heard as separate sounds; instead, they are heard as a single sound coming from the direction of the *first* arriving information; this is called

the *precedence effect*. Echoes are not heard as independent sounds until they follow the original sound by 500-1000 msec (e.g., from a reflecting wall >150 m distant). In normal rooms, echoes follow the original sound by 20-30 msec and are attenuated 1-2 dB from the original; the auditory system seems to suppress the later arriving information for localization purposes (but the sounds are still audible). The initial interaural time difference is much more important in establishing sound source location than subsequent interaural time differences.

An experimental study of the precedence effect using *dichotic* clicks presented via earphone showed that when two pairs of clicks are presented close enough in time to appear as a single, fused sound, the interaural time delay between the first pair of clicks largely determines where the overall sound image will be localized (Figs. 1-3).

Methods

Test Conditions

- Two clicks (AB) presented *binaurally* via earphones (A to left ear, B to right ear) and followed by a second pair (CD) of similar *binaural* clicks (C to left ear, D to right ear)

- 2-msec interval between pairs (entire set of 4 clicks perceived as a single sound at this interval); 10-msec interval for one experiment (click pairs perceived as a double sound)
- First pair of clicks presented simultaneously or separated by a variable interval; second pair of clicks presented simultaneously or

- separated by a variable interval
- Leading ear (left or right) varied for each pair of clicks
- 7-sec interval between trials

Experimental Procedure

- Independent variables: within-pair interval for first pair of clicks, within-pair interval for second pair of clicks, interval between pairs

- Dependent variable: judged location of sound (for computations and plotting, percent of "left" judgments for each stimulus condition was used)
- Subject's task: report direction of sound source as falling in one of six sectors dividing an arc from ear to ear
- 2 subjects, with some practice

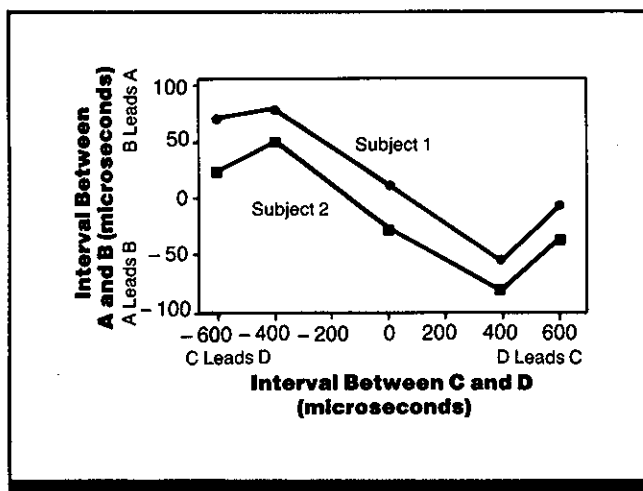

Figure 2. Relative effectiveness of two successive click pairs in determining localization of the total sound image. Dichotic clicks A and B were followed after 2 msec by dichotic clicks C and D. The vertical axis shows the interaural time delay between A and B required to offset the time delay between C and D given on the horizontal axis, so as to produce the perception of a sound image centered on the head. Data are shown for two subjects. (From Ref. 2)

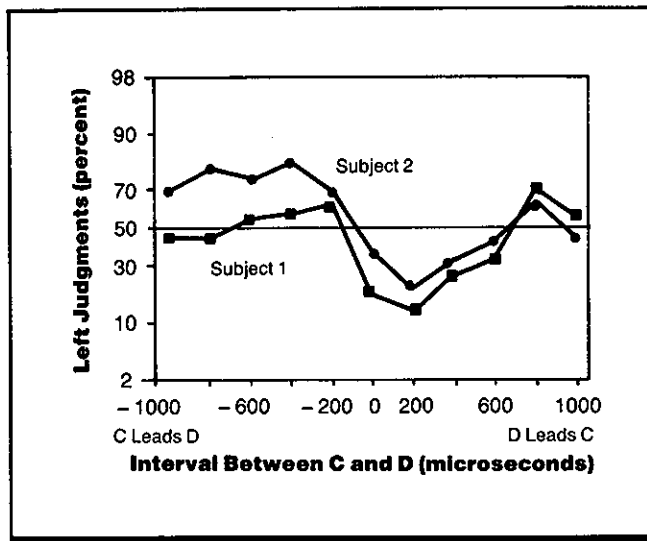

Figure 3. Localization of double click pairs as a function of interaural time delay of the second pair of clicks. Clicks A and B presented simultaneously to the two ears were followed after 2 msec with a second pair of clicks C and D with interaural time delay (interval #2) given on the horizontal axis. (From Ref. 2)

Experimental Results

- Under the given listening conditions, the minimum interaural time difference required for subjects to localize (laterally) clicks presented via earphones as to the left or right of center is 40-45 μ sec. As interaural time delay increases, stimuli are localized increasingly toward the leading ear (Fig. 1). Both subjects show a localization bias (clicks with no interaural delay are localized slightly to the right.)
- When a pair of clicks with interaural time delay is followed closely in time by a pair of clicks with no time delay or a different delay (with all four clicks heard as a single sound image), the apparent location of the sound image depends primarily on the first pair of clicks (precedence effect). However, the sound image is shifted slightly away from the location favored by the first pair of clicks toward the direction favored by the second pair. For example, when the time delay of the second pair of clicks is zero (favoring a localization to the center), the minimum interaural time delay of the first pair required for the sound image to be localized as left or right of center is larger by 6-25 μ sec than the delay required when only the first pair of clicks is presented (comparison of Figs. 1a and 1b).
- The precedence given to the first pair of clicks in determining the localization of the total sound varies as a func-

tion of the interaural time delay of the second pair of clicks. When interaural time delay of the second pair is 400 μ sec, the first pair of clicks is about 6 times more effective than the second pair in determining where the overall sound image will be localized. When interaural delay of the second pair increases to 600 μ sec, however, the first pair is 16-20 times more effective in determining localization (Fig. 2).

- When the first pair of clicks is presented with no interaural time delay (localization in the center of the head) and the interaural time delay of the second pair of clicks is varied, localization varies similarly. For small interaural delays, the total sound is displaced toward the leading ear (of the second click pair). As the delay increases, however, the effect weakens and at very large delays the sound returns to the center, even though these delays are long enough to produce localizations completely to the side of the leading ear if the second pair of clicks was presented alone (Fig. 3).
- When the interpair interval is 10 msec and the within-pair intervals are varied, subjects heard both sets of clicks and could localize each pair.

Variability

Figures show data for both subjects run in the experiments. No information on within-subject variability was reported.

Constraints

- The precedence effect occurs only when the sounds are fused to form a single image and may be overridden if the second sound is sufficiently louder than the first.

Key References

1. Green, D. M. (1976). *An introduction to hearing*. Hillsdale, NJ: Erlbaum.
- *2. Wallach, H., Newman, E. B., & Rosenzweig, M. R. (1949). The precedence effect in sound localization. *American Journal of Psychology*, 62, 315-336.

Cross References

- 2.806 Discrimination of interaural phase differences for pure tones;
 - 2.805 Interaural time differences;
- Handbook of perception and human performance*, Ch. 15, Sect. 3.

Notes



Organization of Entries

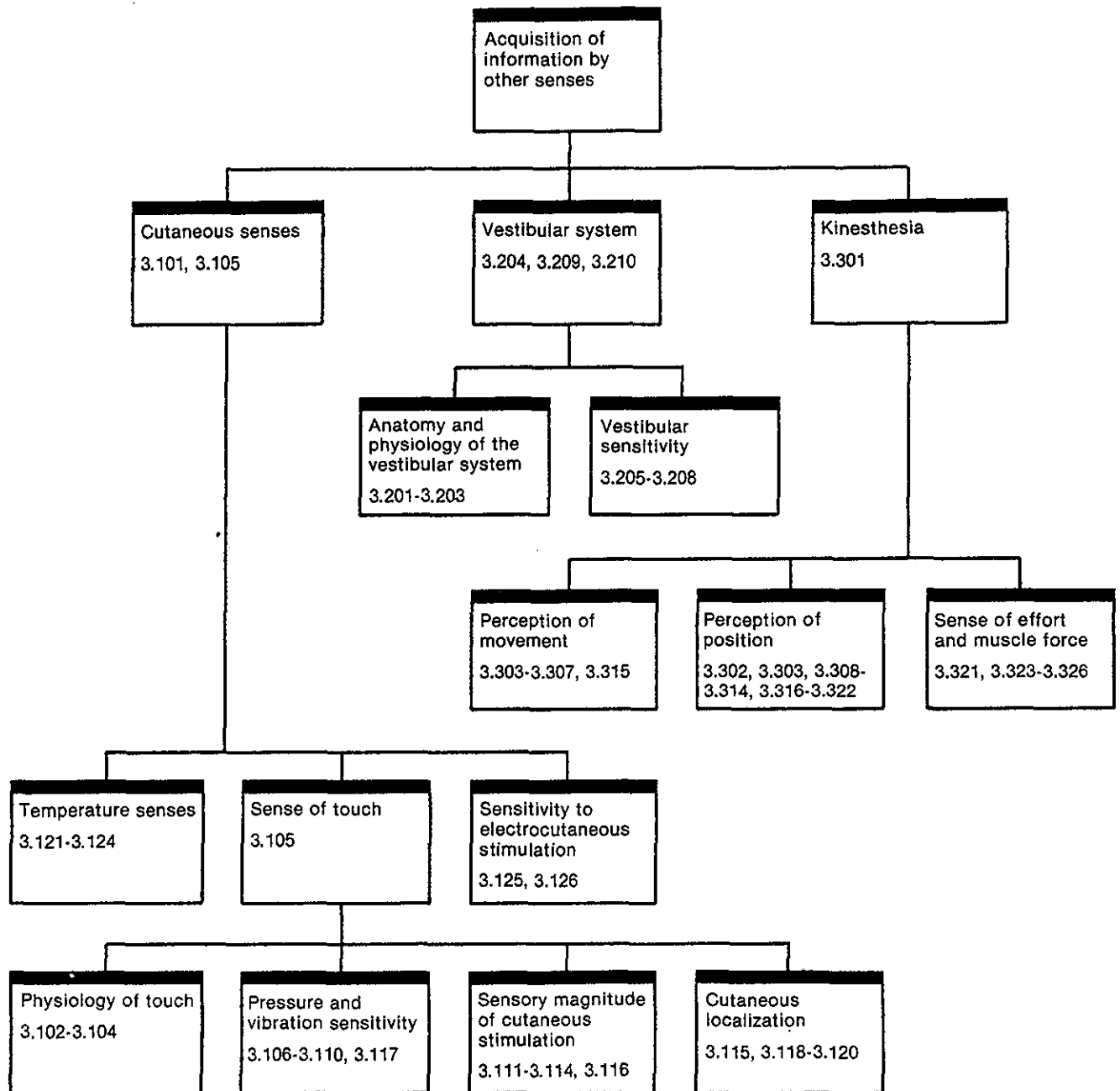

Contents

Section 3.1 Cutaneous Sensitivity

- | | |
|---|--|
| <ul style="list-style-type: none"> 3.101 Cutaneous Sensitivity 3.102 Patterns of Tactile Sensory Innervation over the Body 3.103 Tactile Sensory Innervation of the Skin 3.104 Types of Cutaneous Mechanoreceptors 3.105 Apparatus for Static and Vibratory (Mechanical) Stimulation of the Skin 3.106 Pressure and Vibration Sensitivity 3.107 Vibrotactile Stimulation: Detectability of Tactile Pulses of Varying Duration 3.108 Vibrotactile Stimulation: Effect of Frequency and Type of Spatial Surround 3.109 Vibrotactile Stimulation: Detectability of Intensity Differences 3.110 Vibrotactile Stimulation: Detectability of Intensity Differences in the Presence of Spatial Masking 3.111 Vibrotactile Stimulation: Perceived Magnitude 3.112 Vibrotactile Stimulation: Perceived Magnitude as a Function of Number of Active Vibrators 3.113 Vibrotactile Stimulation: Summation of Perceived Magnitude 3.114 Vibrotactile Stimulation: Enhancement of Perceived Magnitude | <ul style="list-style-type: none"> 3.115 Tactile Localization and Two-Point Discrimination 3.116 Vibrotactile Stimulation: Effect of Adaptation on Detectability and Perceived Magnitude 3.117 Vibrotactile Stimulation: Detectability in the Presence of Masking 3.118 Tactile and Auditory Localization: Effect of Interstimulus-Onset Interval 3.119 Tactile, Auditory, and Visual Shifts in Perceived Target Location Due to Stimulus Interactions 3.120 Apparent Movement of Vibrotactile and Electrocutaneous Stimuli 3.121 Sensitivity to Warmth: Effect of Stimulation Area and Body Site 3.122 Detectability of Warmth and Cold: Effect of Rate of Change in Temperature 3.123 Sensitivity to Warmth and Cold: Effect of Adaptation Temperature 3.124 Perceived Coolness and Warmth: Effect of Intensity and Duration of Stimulation 3.125 Electrocutaneous Stimulation: Effect of Exposure Duration on Sensitivity 3.126 Electrocutaneous Stimulation: Perceived Magnitude |
|---|--|

Section 3.2 Vestibular Sensitivity

- | | |
|---|---|
| <ul style="list-style-type: none"> 3.201 The Vestibular System 3.202 Dynamics of the Otolith Organs 3.203 Dynamics of the Semicircular Canals 3.204 Synergism of Body Rotation and Head Tilt 3.205 Methods for Investigating the Effects of Rotation | <ul style="list-style-type: none"> 3.206 Methods for Investigating Linear Acceleration 3.207 Threshold for Linear Acceleration 3.208 Threshold for Angular Acceleration 3.209 Long-Term Adaptability of the Vestibular System 3.210 Vestibular Illusions |
|---|---|

Section 3.3 Kinesthesia

- | | |
|---|---|
| <ul style="list-style-type: none"> 3.301 Kinesthesia 3.302 Measurement of Position Sense 3.303 Factors Affecting Sense of Position and Movement of Body Parts 3.304 Passive Movement Detectability for Different Joints 3.305 Detectability of Passive Movements of Finger, Elbow, and Shoulder Joints 3.306 Detectability of Passive Rotation of the Hip 3.307 Detectability of Finger Movement 3.308 Perception of Head Position 3.309 Accuracy of Horizontal Arm Positioning: Effect of Direction and Angular Placement 3.310 Perception of Arm Position: Effect of Duration and Location of a Previously Held Arm Position 3.311 Perception of Arm Position: Effect of Active Versus Passive Movement 3.312 Perception of Arm Position: Effect of Active Versus Passive Movement and Practice | <ul style="list-style-type: none"> 3.313 Position Matching of Elbow Angle and Arm Orientation 3.314 Perception of Elbow Angle 3.315 Illusory Motion of the Elbow with Muscle Vibration 3.316 Perception of Shoulder (Arm) Position 3.317 Memory for Shoulder (Arm) Position 3.318 Perception of Finger Displacement 3.319 Perception of Knee Position 3.320 Perception of Ankle (Foot) Position 3.321 Kinesthetic Aftereffects 3.322 Models for the Encoding of Joint Angle 3.323 Heaviness: Effect of Arm Fatigue 3.324 Heaviness: Effects of Anesthesia or Electrocutaneous Stimulation of the Fingers 3.325 Perception of Effort and Force: Effect of Muscle Vibration and Anesthesia 3.326 Tonic Neck Reflex: Influence on Weight Lifting |
|---|---|

Key Terms

- Acceleration, angular, 3.208
Acceleration, constant, 3.210
Acceleration, linear, 3.206, 3.207, 3.210
Adaptation, 3.116
Adaptation, kinesthetic, 3.308, 3.310
Adaptation, thermal, 3.123, 3.124
Ampulla, 3.201
Anesthesia, skin, 3.303, 3.324, 3.325
Ankle joint, 3.320
Ankle rotation, 3.304, 3.320
Apparent movement, 3.120, 3.208
Arm fatigue, 3.323
Arm movement, 3.304, 3.305, 3.315
Arm movement, apparent, 3.315
Arm position, 3.309-3.317
Arm-positioning accuracy, 3.309, 3.316, 3.317
Aubert effect, 3.210
Barany chair, 3.205
Bode plots, 3.203
Body locus, 3.102
Centrifugation, 3.206
Cilia, 3.201
Cold, 3.122-3.124
Coriolis effects, 3.206, 3.210
Cristae, 3.201
Cupula, 3.201, 3.203, 3.204, 3.208
Cupulometry, 3.205
Cutaneous sensitivity, 3.101-3.216
Dermatome, 3.102
Detection. *See* Limb-movement detection; tactile detection
Discrimination. *See* Tactile discrimination; temperature discrimination
Disorientation, spatial, 3.206, 3.208, 3.210
Elbow angle, 3.313, 3.314
Elbow movement, 3.304, 3.305, 3.315
Elbow rotation, 3.304, 3.305, 3.313-3.315
Electrocutaneous stimulation, 3.120, 3.125, 3.126, 3.324
Elevator illusion, 3.210
Endolymph, 3.201
Finger joint, 3.304, 3.305, 3.307, 3.318
Finger movement, 3.304, 3.305, 3.307
Finger position, 3.318
Foot movement, 3.304
Foot position, 3.320
Fourier analysis, 3.205
Habituation, 3.209
Hand movement, 3.201, 3.304
Head position, 3.308
Head tilt, 3.204
Heat, 3.121-3.124
Heaviness, 3.321, 3.323, 3.324
Hip joint, 3.304, 3.306
Hip rotation, 3.304, 3.306
Illusion, weight, 3.321
Illusions, kinesthetic, 3.315, 3.321
Illusions, vestibular, 3.205, 3.208, 3.210
Illusory tilt, 3.210
Interaction, spatial, 3.108
Interaction, spatiotemporal, 3.120
Interaction, stimulus, 3.110, 3.113, 3.114, 3.117, 3.119
Interaction, visual-vestibular, 3.210
Inversion illusion, 3.210
Joint, 3.322
Joint movement, active, 3.302
Joint movement, passive, 3.302, 3.304-3.306
Joint-movement detection, 3.304-3.307
Joint-movement sense, 3.302-3.304, 3.306, 3.307, 3.315
Joint-movement velocity, 3.304, 3.305, 3.307
Joint position, 3.303
Kinesthesia, 3.301-3.326
Kinesthetic adaptation, 3.308, 3.310
Kinesthetic aftereffects, 3.303, 3.308, 3.310, 3.321
Kinesthetic sensation magnitude, 3.306
Kinocilium, 3.201
Knee angle, 3.319
Knee joint, 3.304, 3.319
Knee rotation, 3.304, 3.319
Labyrinth, 3.201
Lateralization, 3.118
Learning, 3.312, 3.319
Leg movement, 3.304, 3.306
Leg position, 3.319
Limb movement, 3.303
Limb movement, active, 3.303, 3.311, 3.312, 3.319
Limb movement, apparent, 3.321
Limb movement, direction of, 3.309
Limb movement, illusory, 3.315, 3.321
Limb movement, passive, 3.303, 3.311, 3.312, 3.319
Limb-movement detection, 3.303, 3.305, 3.306
Limb-movement velocity, 3.303, 3.311
Limb position, 3.303, 3.321
Limb position, memory for, 3.303, 3.316, 3.317, 3.319
Limb-positioning accuracy, 3.303
Localization, auditory, 3.118, 3.119
Localization, tactile, 3.115, 3.118, 3.119
Localization, visual, 3.119
Lumen, 3.201
Maculae, 3.201, 3.202
Magnitude enhancement, 3.114
Magnitude estimation, 3.207, 3.208
Magnitude summation, 3.113
Masking, tactile, 3.110, 3.117
Mechanical pressure, 3.104, 3.105
Mechanoreception, 3.103
Motion perception, 3.120
Movement, apparent, 3.120, 3.208
Mulder's constant, 3.208
Müller effect, 3.210
Muscle contraction, 3.303, 3.315
Muscle effort, 3.325
Muscle fatigue, 3.303, 3.315, 3.323
Muscle loading, 3.303, 3.314, 3.315, 3.318, 3.320
Muscle paralysis, 3.325
Muscle sense, 3.302, 3.303, 3.307, 3.315, 3.318, 3.323-3.325
Muscle tension, 3.325
Muscle vibration, 3.303, 3.314, 3.315, 3.325
Muscle weakness, 3.325
Nervous system, peripheral, 3.102, 3.103
Nystagmus, 3.208, 3.209
Oculogravic illusion, 3.210
Oculogyral effect, 3.205, 3.208
Orientation, spatial, 3.209
Otolith organs, 3.201, 3.202, 3.206, 3.207, 3.210
Peripheral nervous system, 3.102, 3.103
Perrotatory procedure, 3.205
Position encoding, opponent processing model of, 3.322
Position encoding, spatially tuned receptor model of, 3.322
Position sense, 3.301-3.326
Post rotatory procedure, 3.205
Postural persistence, 3.308, 3.321
Practice, 3.312, 3.319
Pressure, 3.104, 3.105
Pressure sensitivity, 3.103, 3.106-3.111, 3.115, 3.117, 3.125
Proprioception, 3.302
Recalibration, 3.209
Rotation, ankle, 3.304, 3.320
Rotation, body, 3.204, 3.205, 3.208
Rotation, elbow, 3.304, 3.305; 3.313-3.315
Rotation, hip, 3.304, 3.306
Rotation, knee, 3.304, 3.319
Rotation, shoulder, 3.304, 3.305, 3.309-3.312, 3.316, 3.317
Rotation, wrist, 3.304
Saccule, 3.201, 3.202
Saltation, sensory, 3.119
Self-motion, 3.207
Semi-circular canals, 3.201, 3.203-3.206, 3.208-3.210
Sensation magnitude, kinesthetic, 3.306
Sensation magnitude, tactile, 3.111-3.114, 3.116, 3.126
Sensation magnitude, thermal, 3.124
Sensitivity, 3.104. *See also* Cutaneous sensitivity, pressure sensitivity, temperature sensitivity, vibration sensitivity
Shoulder joint, 3.304, 3.305, 3.309-3.312, 3.316, 3.317
Shoulder rotation, 3.304, 3.305, 3.309-3.312, 3.316, 3.317
Skin anesthesia, 3.303, 3.324, 3.325
Spatial disorientation, 3.206, 3.208, 3.210
Spatial interaction, 3.108
Spatial orientation, 3.209
Spatial summation, 3.112, 3.121
Spatiotemporal interaction, 3.120
Statoconial membrane, 3.202
Synergy, 3.326
Tactile acuity, 3.115
Tactile detection, 3.106-3.108, 3.116, 3.125
Tactile discrimination, 3.109, 3.110
Tactile masking, 3.110, 3.117
Tactile resolution, 3.115
Tactile sensation magnitude, 3.111-3.114, 3.116, 3.126
Temperature discrimination, 3.123
Temperature sensitivity, 3.121-3.124
Temporal summation, 3.107, 3.125
Thermal adaptation, 3.123, 3.124
Thermal sensory magnitude, 3.124
Thermal stimulation, 3.121, 3.122
Tilt, body, 3.206
Tilt, head, 3.204
Tilt, illusory, 3.210
Toe movement, 3.304
Tonic neck reflex, 3.326
Torsion-pendulum equation, 3.202, 3.203, 3.208
Torsion swing, 3.205
Touch, 3.102-3.120
Two-point threshold, 3.115
Utricles, 3.201, 3.202
Vestibular canals, 3.203, 3.204, 3.206
Vestibular illusions, 3.210
Vestibular sensitivity, 3.201-3.210
Vestibular system, 3.201-3.204, 3.206, 3.208-3.210
Vibration, 3.105
Vibration sensitivity, 3.106-3.114, 3.116, 3.117
Vibrotactile stimulation, 3.105-3.114, 3.116, 3.117, 3.120
Visual-vestibular interaction, 3.210
Weight illusion, 3.321
Weight lifting, 3.326
Weight perception, 3.323, 3.324
Wrist joint, 3.304
Wrist rotation, 3.304

Glossary

- Absolute threshold.** The amount of stimulus energy necessary to just detect the stimulus. Usually taken as the value associated with some specified probability of stimulus detection (typically 0.50 or 0.75).
- Adaptation.** A change in the sensitivity of a sensory organ to adjust to the intensity or quality of stimulation prevailing at a given time; adaptation may occur as an increase in sensitivity (as in dark adaptation of the retina) or as a decrease in sensitivity with continued exposure to a constant stimulus. Also called **sensory adaptation**.
- Afferent.** Conveying neural impulses toward the central nervous system, as a sensory neuron; sensory, rather than motor.
- Bode plot.** A plot in rectangular coordinates showing the magnitude of the input-output ratio of a system (in decibels) and the magnitude of the phase lag as a function of the logarithm of frequency.
- Contactor.** In studies of cutaneous sensitivity, a device that generates vibrotactile stimulation by moving alternately against and away from the skin by force transmitted to it from an electromechanical vibrator. (CRef. 3.105)
- Contralateral.** Pertaining to, occurring on, or acting in conjunction with a similar part on the opposite side of the body.
- Cutaneous.** Pertaining to the skin or receptors in the skin, or to sensation mediated by receptors in the skin.
- Decibel.** A standard unit for expressing the ratio between the power levels of the acoustic or electrical signals. The decibel is sometimes used in cutaneous studies to denote the ratio between two stimulus intensities and is equal to $20 \log I_1/I_2$ (where I_1 and I_2 are the intensities of the two stimuli in the dimension of force, amplitude of displacement, or pressure).
- Dependent variable.** The response to a stimulus presentation measured by the investigator to assess the effect of an experimental treatment or independent variable in an experiment; for example, the investigator might measure the recognition accuracy (dependent variable) for tactile characters of different dimensions to assess the effects of target size (independent variable). (*Compare independent variable.*)
- Difference threshold.** The least amount by which two stimuli must differ along some dimension (such as sound pressure level or frequency) to be judged as nonidentical. Usually taken as the difference value associated with some specified probability of detecting a difference (typically 0.50 or 0.75).
- Distal.** Away from the point of attachment or origin; e.g., the finger is distal to the wrist. (*Compare proximal.*)
- Dorsal.** Pertaining to the back or denoting a position toward the back surface; also, on the limbs, the side opposite the palm or sole.
- Efferent.** Conveying neural impulses away from the central nervous system, as a motor neuron serving a muscle or gland; motor, rather than sensory.
- Electrocutaneous.** Pertaining to electrical stimulation of the skin.
- Electromyography.** The recording and study of the electrical properties of the skeletal muscles (i.e., the electrical activity generated by muscular contraction).
- Ergograph.** An instrument for recording the amount of work done by muscular exertion.
- Factorial design.** An experimental design in which every level or state of each independent variable is presented in combination with every level or state of every other independent variable.
- Haversine pulse.** A single cycle of a sine wave, the zero axis of which is shifted to the minimum value to yield the appearance of a unidirectional displacement.
- Independent variable.** The aspect of a stimulus or experimental environment that is varied systematically by the investigator in order to determine its effect on some other variable (i.e., the subject's response). For example, the investigator might systematically alter the dimensions of a tactile character in order to assess the effect of target size (independent variable) on the observer's tactile recognition accuracy (dependent variable). (*Compare dependent variable.*)
- Innervation.** The distribution or supply of nerves to a body part.
- Interphalangeal.** Situated between two contiguous joints of the fingers or toes.
- Interstimulus-onset interval.** The time between the onset of one stimulus and the onset of a second stimulus.
- Isometric.** Referring to contraction of a muscle against resistance in which there is little shortening of the muscle but muscle tone increases.
- Lateral inhibition.** Inhibitory interactions between neural units serving spatially separated regions; evidenced as a reduction in the sensation or response to stimulation of one area due to stimulation of a nearby area, usually on the skin or on the retina.
- Masking.** A decrease in the detectability of one stimulus due to the presence of a second stimulus (the **mask**) which occurs simultaneously with or close in time to the first stimulus.
- Mechanoreceptor.** A neural structure that responds to mechanical stimuli such as a change in pressure, shape, or tension; the mechanical stimulation may be internal (such as the mechanical events associated with limb movement) or external.
- Medial plane.** The vertical plane passing through the middle of the body from front to back and dividing the body into left and right. Sometimes called **sagittal plane**.
- Method of adjustment.** A psychophysical method of determining a threshold in which the subject (or the experimenter) adjusts the value of the stimulus until it just meets some preset criterion (e.g., just is detectable) or until it is apparently equal to a standard stimulus.
- Method of constant stimuli.** A psychophysical method of determining a threshold in which the subject is presented with several fixed, discrete values of the stimulus and makes a judgment about the presence or absence of the stimulus or indicates its relation to a standard stimulus (e.g., more or less intense).
- Method of limits.** A psychophysical method of determining a threshold in which the experimenter varies a stimulus in an ascending or descending series of small steps and the observer reports whether the stimulus is detectable or not or indicates its relation to a standard stimulus.
- Motor.** Pertaining to structures or functions connected with the activation of muscles or glands.
- Optacon.** From OPTical-to-TACTile CONverter; a reading aid for the blind that converts printed or optical patterns (such as letters) into a corresponding tactile pattern presented to the skin of the index finger pad by means of an array of 144 small vibrators covering an area of approximately 2.7×1.2 cm.
- Passive movement.** Movement of a subject's limb or body by a device or by the experimenter while the subject keeps the moved part as relaxed as possible.
- Peripheral nervous system.** The nervous system excluding the brain and spinal cord.

3.0 Acquisition of Information by Other Senses

- Probit analysis.** A regression-like maximum-likelihood procedure for finding the best-fitting ogive function for a set of binomially distributed data. Originally developed in connection with pharmacological and toxicological assays to compute the lethal or effective dose (dosage affecting 50% of treated organisms); the procedure has also been applied in psychophysical studies in analyzing all-or-nothing (yes/no) responses to compute the 50% threshold (stimulus level eliciting a given response on 50% of trials) and its confidence limits.
- Proximal.** Near the point of attachment of a limb or body part; near the body; e.g., the wrist is proximal to the fingers. (*Compare distal.*)
- Psychometric function.** A mathematical or graphical function expressing the relation between a series of stimuli that vary quantitatively along a given dimension, and the relative frequency with which a subject answers with a certain category of response in judging a particular property of the stimulus (e.g., "yes" and "no" in judging whether a given stimulus is detected, or "less than," "equal to," and "greater than" in comparing the stimulus with a standard stimulus). (CRef. 1.657)
- Randomized design.** An experimental design in which the various levels of the independent variable are presented in random order within a given block of trials or experimental session.
- Receptive field.** For cutaneous neural units, the area of the skin within which stimulation (as by pressure, vibration, etc.) influences the activity of a given sensory neuron. (CRef. 3.103)
- Regression line.** A line on a graph or an equation of a line for predicting the value of one variable from the value of another; the line is derived by statistical methods as representing the relationship between the two variables that best describe a given set of data.
- Sensitivity.** In a general sense, the ability to detect stimulation; in psychophysical studies, refers in particular to the ability to be affected by and respond to low-intensity stimuli or to slight stimulus differences; commonly expressed as the reciprocal of measured threshold.
- Sensory adaptation.** *See adaptation.*
- Spatial summation.** The combining of the sensory response to tactile stimulation impinging simultaneously on spatially separated regions of the skin.
- Staircase procedure.** A variant of the method of limits for determining a psychophysical threshold in which the value of the stimulus on a given trial is increased or decreased depending on the observer's response on the previous trial or group of trials.
- Standard deviation.** Square root of the average squared deviation from the mean of the observations in a given sample. It is a measure of the dispersion of scores or observations in the sample.
- Standard error of the mean.** The standard deviation of the sampling distribution of the mean; mathematically, the standard deviation of the given data sample divided by the square root of one less than the number of observations. It describes the variability of the mean over repeated sampling.
- Temporal summation.** The integration over time of the tactile response to a stimulus falling on a given region of the skin or the combining of the response to two or more stimuli impinging consecutively on the same region of the skin.
- Threshold.** A statistically determined boundary value along a given stimulus dimension that separates the stimuli eliciting one response from the stimuli eliciting a different response or no response (e.g., the point associated with a transition from "not detectable" to "detectable" or from "greater than" to "equal to" or "less than"). (CRef. 1.657) (*See also absolute threshold; difference threshold.*)
- T-test.** A statistical test used to compare the mean of a given sample with the mean of the population from which the sample is drawn or with the mean of a second sample in order to determine the significance of an experimental effect (i.e., the probability that the results observed were due to the experimental treatment rather than to chance). Also known as **Student's t-test**.
- Two-alternative forced-choice paradigm.** An experimental procedure in which the subject is presented on each trial with one of two alternative stimuli and must indicate which stimulus occurred; a response must be made on each trial even if the subject must guess. Commonly referred to as a "criterion-free" method of determining sensitivity.
- Two-point threshold.** The smallest separation between two punctate stimuli applied to the skin that can be discriminated as two stimuli rather than one.
- Vibrotactile stimulation.** A mechanical vibration applied to the skin by an electromechanical transducer such as a modified loudspeaker or electrodynamic mechanical shaker, resulting in a periodic displacement of the skin.
- Von Frey hair (filament).** Hairs of various thicknesses and lengths calibrated to exert a constant force when pressed on the skin.
- Weber ratio.** *See Weber's law.*
- Weber's law.** A law which holds that the smallest detectable change in the magnitude of a stimulus along some dimension is always a constant proportion of the stimulus magnitude from which the difference is noted. The law is expressed mathematically as $\Delta I/I = k$, where I is the magnitude of the stimulus, ΔI is the smallest detectable change in magnitude, and k is a constant which is often called the **Weber fraction** or **Weber ratio**.

Section 3.0 Acquisition of Information by Other Senses

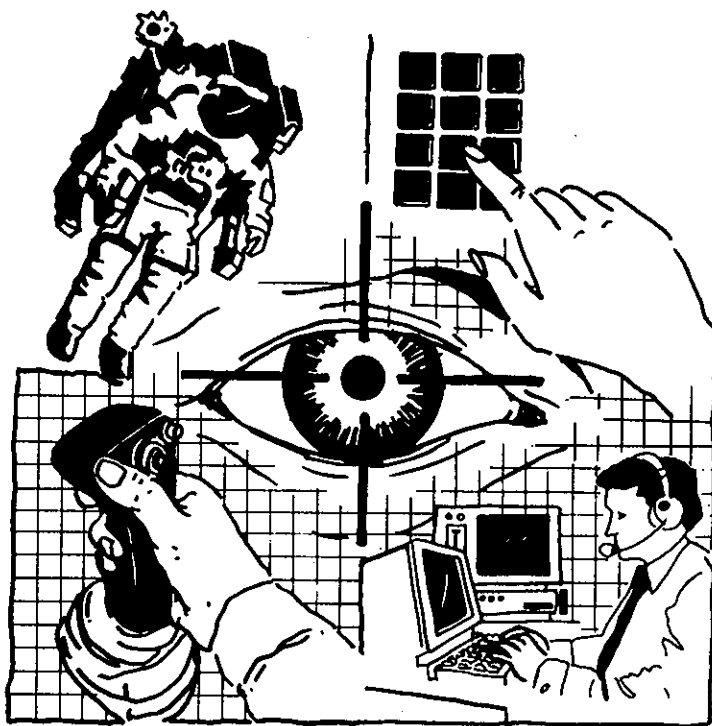

3.101 Cutaneous Sensitivity

General Description

Cutaneous sensitivity includes the apprehension of mechanical, thermal, and **electrocutaneous** stimuli at the skin's surface. These categories, and their combinations, provide for the majority of tactile experiences. Strictly speaking, mechanical and thermal stimuli are the only adequate stimuli for the skin. That is, there appear to be receptors specialized in such ways as to be maximally sensitive to pressure or vibration, or to increases or decreases in normal skin temperature (physiological zero). Because of the bioelectrical nature of nervous transduction, however, electrical stimuli with the appropriate parameters may produce sensations from these receptor systems that mimic those produced by normal stimuli, or may produce sensations unique to that mode of activation. The only other major cutaneous sensation is that of pain, but the adequate stimulus for pain is difficult to specify, and it is often (but not always) associated with tissue damage. Consequently, pain has little value in display design, except perhaps for extreme emergency warning systems.

The patterns of sensitivity of the skin are, to a large degree, determined by the nature of the underlying neural fabric. The organization of this 2-m² organ is more complex than is apparent on brief observation. Superficial inspection reveals a dichotomy between hairy and hairless (or glabrous) skin. Closer examination discloses hills and valleys, pits indicating the presence of sweat glands, and the regular corrugations of the fingertips, underlain by one class of cutaneous receptors, Meissner corpuscles. These and the other receptor types in the skin are discrete structures that, with threshold stimulus intensities, produce the characteristic punctuate sensitivity of the skin. This is simply demonstrated by lightly touching the skin on the back of the hand with a pencil, noting how the "bright" points of cold are distributed. A similar array can be recorded for **vibrotactile** and warm stimuli. Furthermore, owing both to differences in innervation density and to characteristics of the skin surface, sensitivity and resolution change from site to site over the surface of the body.

Nevertheless, under normal conditions, the receptor structures in the skin cannot be treated as isolated points of sensitivity. Owing to the nature of the tissues in which they are embedded, interactions of many kinds with distant structures may take place. With mechanical stimulation, for example, rigid surrounds often ring the tip of the contactor delivering the stimulation. In this case, travelling waves on the skin's surface might be blocked, but the underlying tissues can transmit compression and shear waves over considerable distances. In addition, the presence of underlying bone or organ tissue tends to influence the sensation, particularly from mechanical stimuli. These influences, as well as the considerable overlap of receptive fields for tactile receptors, contribute to spatial interactions of several types.

Because of these factors, the spatial resolving capabilities of the skin are not very acute. Certainly whenever they are compared, vision tends to outstrip touch in fineness of spatial discrimination. But touch is often used to verify

proximal spatial judgments. Two typical measures, the error of localization and the two-point threshold, demonstrate spatial resolution and can map its variation across the body's surface. Two-point resolution is ability to discriminate two-point from one-point touch. At some body sites, two-point resolution may be as small as a millimeter or so (on the fingertip), or as large as 60 mm (on the thigh). A large degree of spatial integration still occurs across these surfaces. With compact arrays of contactors, for example, overall vibrotactile sensation magnitude (loudness) increases in direct proportion to the number of active elements in a pattern. Similarly, the ability to identify objects, such as knobs, by handling (stereognosis) may require a fusion of tactual information. Texture, temperature, hardness, and mass all are integrated, seemingly at a moment's touch, to enable us to recognize and discriminate complex three-dimensional objects.

Similarly, owing to the temporal proximity between events, neural interplay at local and higher levels in the transmission systems provides for the possibility of interaction of information from discrete stimuli. Such interactions are described in the literature as masking, summation, enhancement, or integration. At one level, this situation may appear to degrade information transmission by limiting the rate at which discrete signals might be sent. On the other hand, because of this blurring of stimuli, including the smoothing of the transition between two successive signals, chunking of information might more readily develop. In speech, for example, the characteristics of uttered sounds will depend on the preceding and following sounds. This is owing primarily to the physical constraints on the production system ("She sells sea shells . . ."), but, in any case, the smooth ebb and flow of speech is readily apprehended. In fact, if, as in speech reading, a visual signal and only the low-frequency prosody or rhythm of speech are available, an untrained person can readily understand what is being said.

Another characteristic of tactile sensitivity associated with the temporal dimension is adaptation. In general, this refers to a reduction in sensitivity following continued stimulation. The definition of adaptation changes if one is studying physiological responses, or more complex behavior. Nevertheless, continued stimulation tends to change the response characteristics of all sensory systems. Before it is assumed, however, that adaptation has taken place, one must ensure that the stimulus indeed continues unabated. In the case of pressure stimuli, for example, adaptation was found to accompany the end of progressive indentation into the skin. In this case, adaptation was actually an instance of stimulus failure. That is, the adequate stimulus in a pressure stimulus was actually movement into the skin (indenting movement), and when that ceased, so did the sensation. Vibrotactile adaptation does take place, but may not run to completion even after 15 min of stimulation. However, cross-adaptation, in which the test frequency differs from the adapting frequency, only occurs when both frequencies are either high or low in the response spectrum of roughly

20-400 Hz. If the frequency of one stimulus is greater than 80-100 Hz, and the other smaller, then adaptation will be minimal, if it occurs at all. It appears as though two different receptor systems subservise the two frequency ranges, and stimulation of one does not influence the sensitivity of the other. Thermal adaptation similarly demonstrates the differential performance of two different systems. Whereas adaptation to warmth takes place rapidly and appears to asymptote within 2-4 sec, the magnitude of cold sensations continues to increase, albeit slowly, after even 30 sec of continued stimulation.

The Anatomic Correlates of Touch

- The type of underlying receptor structures in the skin appears to influence the quality of tactile sensitivity at a site (CRef. 3.103). Furthermore, the information from local structures interacts with that from more distant sites as information travels towards the central nervous system (CRef. 3.102).
- Local site characteristics, such as innervation density and receptor population, will influence thresholds to pressure and vibration (CRef. 3.106), and the sensation magnitude of suprathreshold vibratory and thermal stimuli (CRefs. 3.111, 3.121). Spatial acuity and resolution are similarly influenced by body site (CRef. 3.115).
- Thresholds and suprathreshold sensation magnitudes depend on stimulus frequency over the normal vibrotactile dynamic range of 20-400 Hz, with maximal sensitivity centered ~200-250 Hz (CRefs. 3.106, 3.108, 3.111). Furthermore, because different receptor systems appear to subservise low versus high frequency sensitivity, enhancement and summation effects are similarly dependent on frequency (CRefs. 3.113, 3.114).
- Certain temporal interactions take place only within restricted spatial domains. Vibrotactile masking, for example, is minimal if the stimuli are widely separated (CRef. 3.117). Similarly, saltation (apparent displacement in spatial location of a stimulus) (CRef. 3.119) has well-defined spatial limits, e.g., the illusion cannot be observed across the midline of the body.
- The spatiotemporal course of cutaneous saltation on the thigh is the same as that on the forearm, and follows a course similar to visual and auditory saltation (CRef. 3.119).
- Thermal spatial summation, in which thresholds fall as the area of the stimulation increases, progresses at the same rate on the back, forearm, and forehead, although for a given stimulator size, sensitivity increases from back to forehead (CRef. 3.121).

Tactile Thresholds

- The **absolute threshold** for a single tap is a function of body site (CRef. 3.106) and stimulus duration (CRef. 3.107). Vibrotactile thresholds are a function of body site (CRef. 3.106, 3.111), stimulus frequency (CRef. 3.108), and the nature of the surround-contact relationship (CRefs. 3.105, 3.108), as well as contactor size (inferred from CRef. 3.112).
- The vibrotactile frequency response for tactile contactors >3-4 mm in diameter has a dipper-shaped function (CRef. 3.108). (Below that size, thresholds tend to be high and the function is much flatter.) Note that the range of intensities over the decade 20-200 Hz can be as great as 20 dB or more. The response characteristics of the shakers

used as stimulators must be taken into account in a design system, for the intensities required just to achieve threshold at the lower frequencies may tax many systems (CRef. 3.105). Suprathreshold stimuli, in the range of 1520 dB above threshold are usually comfortable for most signaling purposes.

- Thermal thresholds are a function of the temperature to which the skin has been adapted (CRef. 3.123), rate of temperature change from physiological zero (CRef. 3.122), and the area of the stimulus and site of stimulation (CRef. 3.121). The mode of stimulation, however, whether the heat is conducted or radiated, does not affect the results (CRef. 3.121).
- **Difference thresholds** provide information on the resolution of the system: what is the smallest perceptible difference in the quality of stimulation? For vibration, a difference of ~20% in intensity is just perceptible at 160 Hz, regardless of baseline intensity from 14-35 dB above threshold (CRef. 3.109), or level of masking stimulus (CRef. 3.110). For 2-msec taps, on the other hand, intensity difference thresholds drop from 35% to ~20% over the same range of baseline intensities (CRef. 3.109).
- Difference thresholds for changes in temperature depend on the level of thermal adaptation of the skin (CRef. 3.123).
- Thresholds for location on the skin's surface are determined by two methods: error of localization and **two-point threshold**. These are well correlated over the surface of the body, and are smallest (highest sensitivity) on the fingertips and lips (CRef. 3.115).

Temporal Interactions

- **Masking** of one stimulus by another is only one of many types of cutaneous temporal interactions. Depending on the temporal (and spatial) proximity of a masking stimulus to a test stimulus, the apparent intensity of the test may be reduced, perhaps by as much as 20 dB re threshold (CRef. 3.117). A masking stimulus does not appear to affect the magnitude of vibrotactile difference thresholds (CRef. 3.110).
- If two frequencies are within the same "half-band," i.e., above or below 80-100 Hz, and separated by 100-500 msec, the subjective magnitude of the second may be enhanced by the presence of the first (CRef. 3.114). If the two frequencies do differ considerably, the overall loudness of the pair may be found to sum over the same range of interstimulus intervals (CRef. 3.113).

Spatiotemporal Interactions

- If two pulsing stimuli are presented to separate skin sites < 10 cm apart, and if the interstimulus interval is less than ~300 msec, certain types of illusions may appear (CRefs. 3.118, 3.119, 3.120).
- If the interstimulus interval is less than ~2 msec and the stimuli are carefully matched in tactile loudness, their apparent loci may fuse and appear closest to the locus of the leading stimulus (CRef. 3.118). Changing the stimulus onset asynchrony from +2 to -2 msec moves the fused image from one site to the other. This illusion has been used to signal position in a prosthetic arm.
- For interstimulus intervals between 20 and 250-300 msec, the perceived location of the second tap will be fairly close to veridical, but the apparent locus of the leading tap will be displaced toward that of the following tap. The shorter

3.1 Cutaneous Sensitivity

the time, the greater the displacement (CRef. 3.119). Similar effects are seen in vision and audition.

- When interstimulus intervals are ~100 msec and stimuli are relatively long vibratory bursts, apparent movement is perceived. That is, a "gray ghost" of a sensation appears to move from the first to the second site (CRef. 3.120). The same functional relationship is seen for visual and electrocutaneous stimuli (CRef. 3.120).

Adaptation

- Vibrotactile adaptation and recovery may take many minutes to complete. Testing sensitivity to the same frequency as is used for adaptation by either matching techniques or by threshold testing shows adaptation continuing even after 15 min of stimulation (CRef. 3.116). When the test and adapting frequencies are on either side of 80-100 Hz, however, cross-adaptation is minimal.
- Thermal adaptation is familiar to anyone who swims or washes dishes—the initial sensation of warmth or coolness declines after continued exposure. There are limits, however, within which complete adaptation occurs—below

Methods of Stimulation

Three major classes of mechanical stimuli are step functions, impulse functions, and periodic functions. With step functions, displacement of the skin is effected and held for a significant period of time (1 sec or more). An impulse function is a transient of some given waveform imparted to the skin for a few milliseconds. Periodic functions displace the skin at constant or variable frequencies for several milliseconds.

These forms of stimuli are imparted to the skin mostly by electromechanical transducers (e.g., modified loudspeakers or electrodynamic mechanical shakers; CRef. 3.105).

Early studies used air jets, tuning forks, and von Frey hairs (calibrated filaments pressed against the skin). Recently developed piezoceramic elements allow for the design of compact arrays of many mechanical transducers. Small accelerometers or solid-state resistive strain gauges are generally used to quantify the movement of the driver element.

Constraints

- Because stimulation of the skin involves activation of many receptor systems, assumptions regarding the underlying populations of structures contributing to a sensation should be made with caution.
- The magnitude of sensations produced by prolonged stimulation will suffer from adaptation after several minutes of continued presentation.
- Display systems using vibration frequency for encoding parameters of the display should (1) limit the number of frequencies to fewer than 7-9, and (2) employ changes in frequency >20%. If the display system depends on intensity changes, the number of levels should be limited to fewer than four.
- The level of thermal adaptation of the skin will not only affect the perception of thermal changes, but will also affect judgments of rate of vibration, as well as vibrotactile thresholds.
- Individual differences in many of these measures are great enough that thresholds should be taken on each subject if precise quantification of the function is desired.

~31°C or above ~36°C, a persisting cool or warm sensation exists regardless of the duration of stimulation (CRef. 3.123). The speed of adaptation, as disclosed by changes in sensation magnitude, appears to be much greater for warmth than for cold (CRef. 3.124).

Electrocutaneous Stimulation

- Display systems employing electrocutaneous stimuli often hold an advantage over vibrotactile systems because of mechanical ruggedness. With new piezoelectric vibrator materials, energy considerations are less significant. Nevertheless, temporal summation takes place with electrocutaneous stimuli in almost exactly the same manner as with mechanical stimuli (CRefs. 3.108, 3.125).
- The growth of sensation magnitude for electrocutaneous stimuli is more rapid than that for any other stimulus modality. The power function has an exponent close to 3.0 (CRef. 3.126), whereas vibrotactile exponents are in the range of 1.0 (CRefs. 3.111, 3.112).

Previously, the common unit of measurement was amplitude or unit of force per unit radius or per unit area. However, due to the variation of skin impedance with frequency of the stimulus, energy is now considered a better measure of stimulus intensity.

The most commonly used devices for studying the thermal sensitivity of the skin are radiant energy devices such as high-intensity lamps, infrared heating lamps, and microwave energy sources, and devices that conduct heat toward or away from the skin such as liquid heat exchangers and electrical thermodes.

Electrocutaneous stimulation involves the passage of electrical currents through the skin. Electrodes of many sizes, shapes, compositions, and configurations have been used to stimulate a number of different body sites. Waveforms for electrical stimulation have generally been limited to sinusoidal, rectangular, and triangular waveforms, as well as white noise.

- The absolute values of many of these measures are very dependent on the task demands. This is particularly well demonstrated by the history of the measure of the two-point threshold. Methods such as the **two-alternative forced-choice** procedure tend to produce lower and more consistent thresholds than measures such as the **method of limits**.
- In many of these tasks, learning the task may play a significant role in determining the final outcome. Even in as simple a task as the measurement of the two-point threshold, sensitivity appears to increase by a factor of as much as 100 over 20 days of practice. Initial improvement is often simply task-related: becoming comfortable with the keypad or getting used to the vibrotactile stimulus, for example. Conclusions based on data obtained from early sessions should take such learning into consideration.
- Perceptual learning may take hundreds of trials to go to completion. Consideration should be given to the potential sluggishness of learning, particularly in augmentation display systems. It takes a child many months of practice to learn to shape the repertoire of specific sounds that adults call speech, and telegraphers may take almost a year to learn to read and send Morse code at line rates.

Key References

1. Békésy, G. von (1967). *Sensory inhibition*. Princeton, NJ: Princeton University Press.
2. Boring, E. G. (1942). *Sensation and perception in the history of experimental psychology*. New York: Appleton-Century.

3. Carterette, E. C., & Friedman, M. P. (1978). *Handbook of perception. Vol. VI B: Feeling and hurting*. New York: Academic Press.
4. Kenshalo, D. R. (Ed.). (1979). *Sensory functions of the skin of humans*. New York: Plenum.

5. Melzack, R., & Wall, P. D. (1962). On the nature of cutaneous sensory mechanisms. *Brain*, 85, 331-356.
6. Sherrick, C., & Cholewiak, R. W. (1986). Cutaneous sensitivity. In K. R. Boff, L. Kaufman, & J. P. Thomas (Eds.), *Handbook of perception and human perfor-*

- mance: Vol. I. Sensory processes and perception*. New York: Wiley.
7. Sinclair, D. C. (1967). *Cutaneous sensation*. London: Oxford University Press.
8. Tregear, R. T. (1966). *Physical functions of the skin*. New York: Academic Press.

Cross References

- 3.102 Patterns of tactile sensory innervation over the body;
- 3.103 Tactile sensory innervation of the skin;
- 3.105 Apparatus for static and vibratory (mechanical) stimulation of the skin;
- 3.106 Pressure and vibration sensitivity;
- 3.107 Vibrotactile stimulation: detectability of tactile pulses of varying duration;
- 3.108 Vibrotactile stimulation: effect of frequency and type of spatial surround;

- 3.109 Vibrotactile stimulation: detectability of intensity differences;
- 3.110 Vibrotactile stimulation: detectability of intensity differences in the presence of spatial masking;
- 3.111 Vibrotactile stimulation: perceived magnitude;
- 3.112 Vibrotactile stimulation: perceived magnitude as a function of number of active vibrators;
- 3.113 Vibrotactile stimulation: summation of perceived magnitude;
- 3.114 Vibrotactile stimulation: enhancement of perceived magnitude;

- 3.115 Tactile localization and two-point discrimination;
- 3.116 Vibrotactile stimulation: effect of adaptation on detectability and perceived magnitude;
- 3.117 Vibrotactile stimulation: detectability in the presence of masking;
- 3.118 Tactile and auditory localization: effect of interstimulus-onset interval;
- 3.119 Tactile, auditory, and visual shifts in perceived target location due to stimulus interactions;
- 3.120 Apparent movement of vibrotactile and electrocutaneous stimuli;

- 3.121 Sensitivity to warmth: effect of stimulation area and body site;
- 3.122 Detectability of warmth and cold: effect of rate of change in temperature;
- 3.123 Sensitivity to warmth and cold: effect of adaptation temperature;
- 3.124 Perceived coolness and warmth: effect of intensity and duration of stimulation;
- 3.125 Electrocutaneous stimulation: effect of exposure duration on sensitivity;
- 3.126 Electrocutaneous stimulation: perceived magnitude

3.102 Patterns of Tactile Sensory Innervation Over the Body

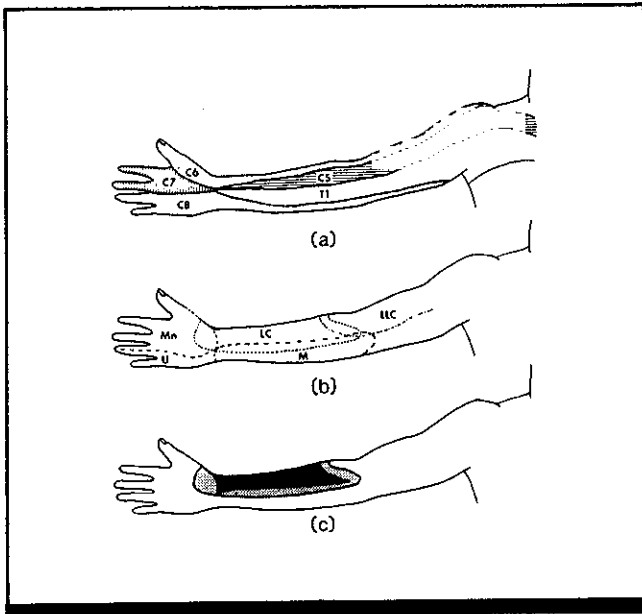

Figure 1. Regions of innervation showing (a) several dorsal root dermatomes, (b) peripheral nerve receptive fields for the median (Mn), ulnar (U), medial (M), lower lateral cutaneous (LLC), and lateral cutaneous (LC) nerves, and (c) areas of complete (black) and partial (dark stipple) anesthesia caused by severing the lateral cutaneous nerve. (From Handbook of perception and human performance, adapted from Ref. 3)

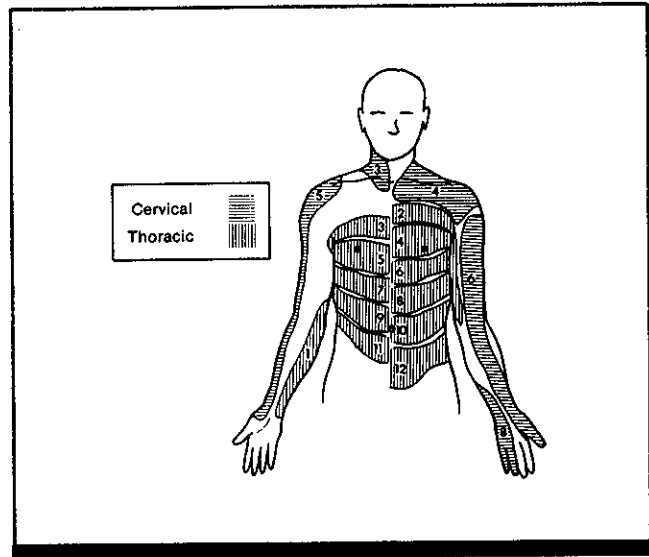

Figure 2. Areas of skin (dermatomes) innervated by cervical roots or thoracic roots. (Dermatome overlap is not shown.) (From Handbook of perception and human performance, based on data of Ref. 1)

Key Terms

Body locus: dermatome; peripheral nervous system; touch

General Description

The afferent (sensory) portion of the peripheral nervous system is comprised of nerves that carry information about stimuli in the environment to the central nervous system (the spinal cord and the brain). Each individual cutaneous sensory nerve fiber serves a region of the skin, called a receptive field, which overlaps with receptive fields of other individual nerve fibers. Individual fibers travel together in peripheral nerves and the receptive fields of the peripheral nerves also overlap (Fig. 1b). Degree of overlap is location-dependent; there is relatively little overlap on the hand and

greater overlap on the trunk. Therefore, loss of any given peripheral nerve produces only partial anesthesia in the served region (e.g., on the trunk) or a zone of complete anesthesia surrounded by an area of partial anesthesia (e.g., on the arm, Fig. 1c). In turn, the fibers that form peripheral nerves gather into dorsal nerve roots which serve restricted regions of the skin. An area of skin supplied by fibers of a given spinal root is called a dermatome (Figs. 1a, 2). Dermatomes exhibit even more overlap, so that destruction of a dorsal nerve root produces only partial anesthesia in the associated dermatome.

Applications

Designs in which the relationship between regions of sensitivity and patterns of innervation (distribution of nerves) must be understood.

Methods

• Microneurography used to map receptive fields of individual fibers (CRef. 3.103); method of residual sensibility used to map receptive fields of nerves and dermatomes

- Receptive fields of peripheral nerves studied in patients with nerve injuries or blocks
- Independent variables: peripheral nerve fiber stimulated; peripheral nerves injured or blocked; nerve root severed

- Dependent variable: reported region of sensitivity
- Subject's task: report region of sensation or point of transition of sensation at borders of region
- Dermatomes (Fig. 2) can be mapped experimentally in animals by severing three roots above and

- three roots below an intact root and examining the effects on sensitivity
- Peripheral nerves and dermatomes studied at various body sites
- Data are representative of various subjects in various investigations

Experimental Results

- Although the regions depicted as dermatomes vary somewhat from subject to subject and with different methods of investigation, those presented are generally accepted as the standard clinical dermatomal map.

Repeatability/Comparison with Other Studies

Similar results have been found using different methods of investigation (e.g., Ref. 2).

Constraints

- Different dermatomal maps have appeared as consequence of the various methods of interfering with dorsal root innervation.

Key References

- *1. Foerster, O. (1933). The dermatomes in man. *Brain*, 56,1-39.
- 2. Head, H. (1920). *Studies in neu-*

rology. London: Oxford University Press.

- *3. Sinclair, D. C. (1967). *Cutaneous sensation*. London: Oxford University Press.

Cross References

- 3.103 Tactile sensory innervation of the skin;
- 3.104 Types of cutaneous

mechanoreceptors;
Handbook of perception and human performance,
Ch. 12, Sect. 1.4

3.103 Tactile Sensory Innervation of the Skin

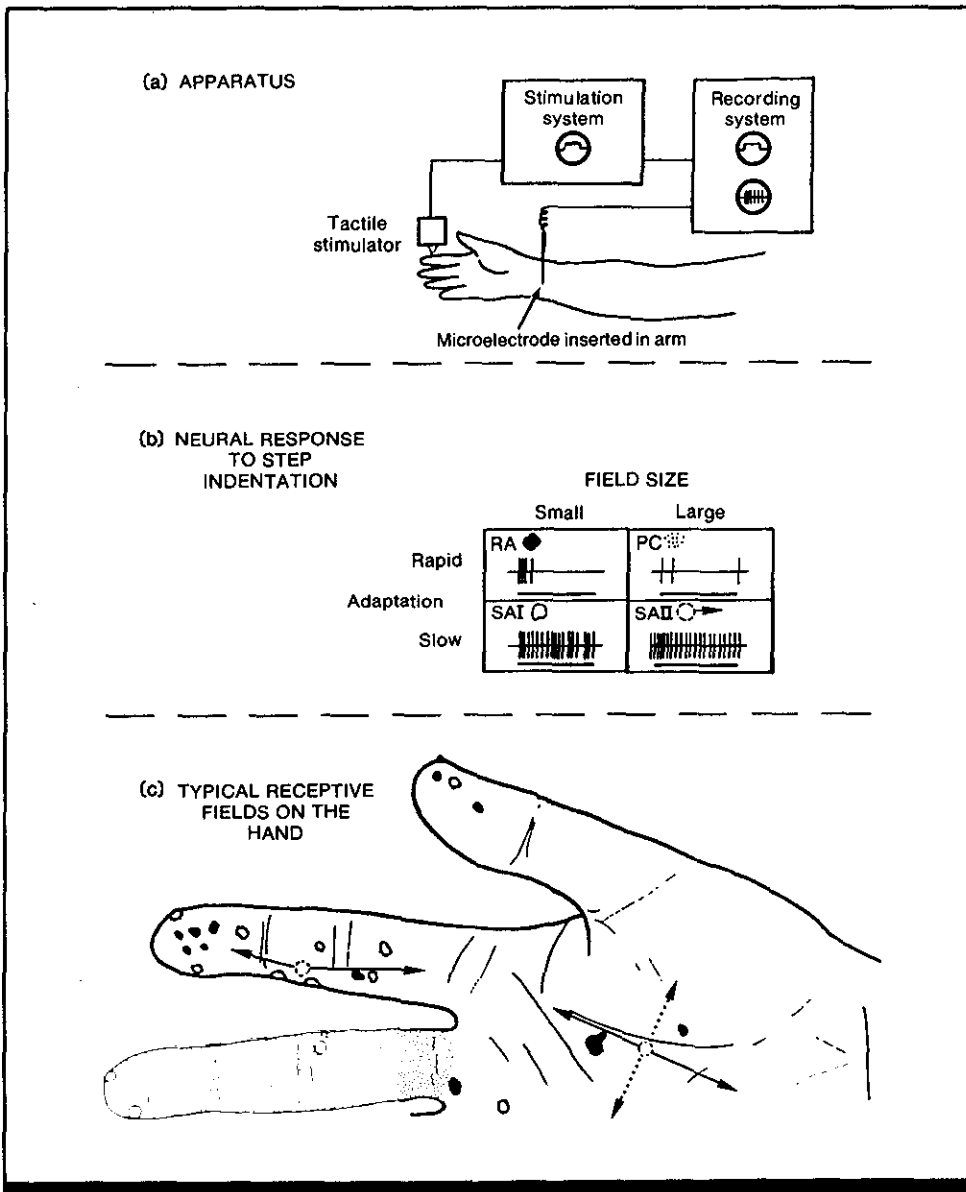

Figure 1. (a) Apparatus used to map responses of single afferent (sensory) units to tactile stimulation (method of microneurography). (b) Four afferent receptor types, with characteristic response patterns (vertical bars represent nerve impulses; stimulus duration indicated by solid bar under neural pattern). (c) Mapping of a few representative receptive fields, showing location and extent. Filled solid black areas are receptive fields for RA units. The dark shading on the middle finger indicates a PC receptive field with P marking point of maximal sensitivity. Open areas with solid perimeters are SAI receptive fields. Open areas with dotted perimeters are SAII receptive fields. Solid arrows indicate directions of skin stretch that increase spontaneous SAII activity. Dotted arrows indicate directions of stretch that inhibit spontaneous activity. (From Ref. 4)

Key Terms

Mechanoreception; peripheral nervous system; pressure sensitivity; touch

General Description

Microelectrode recordings from nerve structures responsive to the mechanical stimulation of the glabrous (hairless) skin of the hand reveal four types of sensory units (Fig. 1) which may be categorized on two dimensions: (a) rate of adaptation to skin indentation and (b) size and distinctiveness of the borders of their receptive fields (region of skin served by the unit). The four types include:

(1) rapidly adapting (RA)—adapts rapidly to mechanical

stimulation and has a small receptive field with distinct borders

(2) Pacinian (PC)—adapts rapidly to mechanical stimulation and has a large receptive field with indistinct borders

(3) slowly adapting I (SAI)—adapts slowly to mechanical stimulation and has a small receptive field with distinct borders

(4) slowly adapting II (SAII)—adapts slowly to mechani-

cal stimulation and has a large receptive field with indistinct borders.

The end-organs (organs at the terminus of the nerve structure) believed to be associated with three of the unit types are shown in Fig. 2. The Meissner corpuscles are as-

sumed to be associated with the RA receptive fields, Pacinian corpuscles with PC fields, and Merkel endings with SAI fields. The Ruffini endings associated with the SAII fields (not shown in Fig. 2) are located in the dermis, away from the epidermal-dermal border.

Applications

Designs incorporating hand-held objects used for control or analysis. Designs in which the hand is involved in form, textural, or spatial analysis. Designs in which vibration of a part of the hand is critical.

Constraints

- Although there is general agreement regarding the role of the Pacinian corpuscle in **mechanoreception** in humans, the exact functions of the other receptors so far identified are not nearly as well understood as are their morphology,

distribution, and mechanisms of innervation.

- Some researchers warn against associating types of neural elements with types of tactile sensitivity (e.g., mechanical or thermal).

Key References

1. Burgess, P. R., & Perl, E. R. (1973). Cutaneous mechanoreceptors and nociceptors. In A. Iggo (Ed.) *Handbook of sensory physiology, Vol. II: Somatosensory system* (pp. 29-78). New York: Springer-Verlag.

2. Iggo, A. I., & Andres, K. H. (1982). Morphology of cutaneous receptors. *Annual Review of Neuroscience*, 5, 131.

3. Johansson, R. S. (1979). Tactile afferent units with small and well demarcated receptive fields in the glabrous skin area of the human hand. In D. R. Kenshalo (Ed.), *Sensory functions of the skin of*

humans (pp. 129-152). New York: Plenum.

4. Sherrick, C. E., & Cholewiak, R. W. (1986). Cutaneous sensitivity. In K. R. Boff, L. Kaufman, & J. P. Thomas (Eds.), *Handbook of perception and human performance: Vol. I., Sensory processes and perception*. New York: Wiley.

5. Vallbo, A. B., & Johansson, R. S. (1978). The tactile sensory innervation of the glabrous skin of the human hand. In G. Gordon (Ed.), *Active touch: The mechanism of recognition of objects by manipulation: A multidisciplinary approach* (pp. 29-54). Oxford: Pergamon.

Cross References

3.102 Patterns of tactile sensory innervation over the body;

3.104 Types of cutaneous

mechanoreceptors;

Handbook of perception and human performance, Ch. 12, Sects. 1.4, 4.1

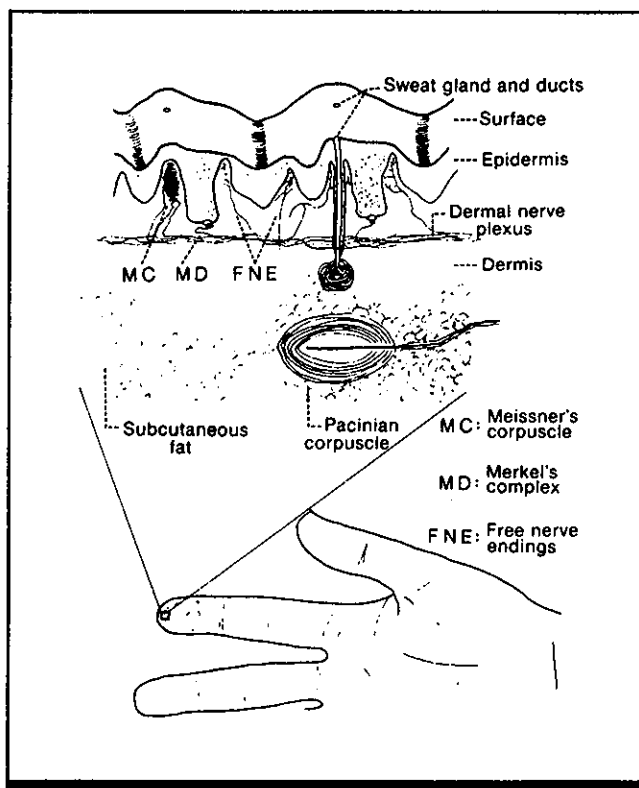

Figure 2. Major non-neural and organized neural elements in fingerprint skin. (From Ref. 4)

3.104 Types of Cutaneous Mechanoreceptors

Key Terms

Pressure; sensitivity; touch

General Description

The mechanoreceptors of the cat are assigned to 11 groups based on their response to stimulation (indentation) of the skin. The table classifies receptor type in terms of the (1) conduction velocity of neural axons innervating the receptor, (2) threshold behavior of the receptor to sinusoidal

stimulation of increasing frequency and decreasing duration (mean slope of tuning curve), (3) type of response to transient skin indentation (ramp response), and (4) duration of receptor response to a maintained indentation of the skin (plateau response).

Applications

Designs for which response of mechanoreceptors to stimulation of the skin must be considered.

Constraints

- Conduction velocities for humans are 20% slower than those for the cat.
- The relationship between cutaneous responses and kinesthesia has not been extensively studied, and it is not known if the skin plays any significant role in kinesthesia.

Table 1. Characteristics of some mechanoreceptors. (Adapted from Ref. 1)

Receptor Type	Mean Peripheral Conduction Velocity (m/sec)	Mean Slope of Tuning Curve ^a	Type of Ramp Response ^b	Plateau Response
C	< 2	No Response	V/D	< 20 sec
AΔ	20	-0.4	V	Little or none
G ₂ hair	50	-0.2	V/D	Little
G ₁ hair	65	-0.4	V	None
G ₁ hair	75	-1	V/A	None
F ₂ field	50	-0.15	V/D	< 20 sec
F ₁ field	55	-0.25	V	None
F ₁ field	65	-0.6	V	None
T ₂ (Ruffini)	55	0	D	Persists
T ₁ (Merkel)	65	0	D/V	Persists
Pacinian	65	-2	A	None

^a A slope of 0 indicates pure displacement sensitivity; a slope of -1, pure velocity sensitivity; and a slope of -2, pure acceleration sensitivity;

^b A = acceleration response (responds only at onset and offset of displacement);

D = displacement response (response increases with displacement);

V = velocity response (response to displacement is constant)

Key References

*1. Horch, K. W., Tuckett, R. P., & Burgess, P. R. (1977). A key to the classification of cutaneous mechanoreceptors. *Journal of Investigative Dermatology*, 69, 75-82.

Cross References

3.102 Patterns of tactile sensory innervation over the body;

3.103 Tactile sensory innervation of the skin;

Handbook of perception and human performance,
Ch. 13, Sect. 2.1.2

3.105 Apparatus for Static and Vibratory (Mechanical) Stimulation of the Skin

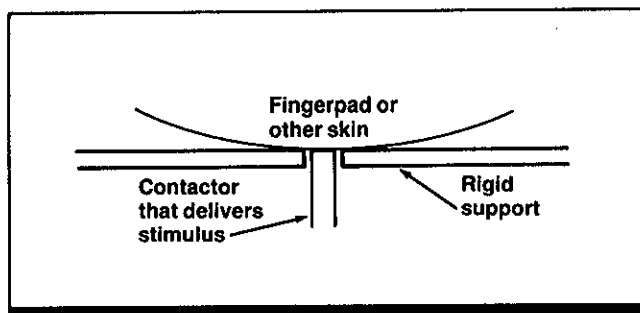

Figure 1. Schematic of single-channel apparatus typically used to deliver vibrotactile stimuli to the skin when a static surround is present. The diameter of the hole in the rigid support is usually 2 mm larger than the diameter of the contactor when a static surround is present (providing a 1-mm gap) and much larger in diameter when a static surround is absent.

Key Terms

Mechanical pressure; touch; vibration; vibrotactile stimulation

General Description

Mechanical stimulation of the skin involves the application of force to the skin surface to bring about displacement in skin position. The force applied to the skin may either be constant over time (static) or may vary periodically (vibrate) at some specified frequency. Both types of stimuli have

been used at sites over the entire body. The arms and hands are usually used for studies not directly concerned with body locus, primarily because these are the sites normally employed in tactile exploration and manipulation of the environment. Table 1 lists some devices for mechanical stimulation of the skin and describes their typical uses.

Table 1. Devices for mechanical stimulation of the skin.

Type of Force	Device	Typical Use
Static	Blunt-tipped stylus pressed against the skin with uncalibrated force	Clinical determination of presence or absence of skin sensitivity; measurement of errors of localization
	Von Frey hairs that bend when pressed against the skin (i.e., filaments of varying thickness that exert a specific calibrated force as they bend)	Determination of thresholds for pressure sensitivity
	Electromechanical devices designed for specific experiments (size and shape vary)	Apply stimuli of specified force and duration (e.g., to determine thresholds)
	Two blunt-tipped styli as calipers (distance between points is calibrated)	Determination of two-point threshold (minimum spatial separation for two points to be judged as two rather than one)
Vibratory	Skin contactor alternately moved against and away from the skin by an electromechanical vibrator (or vibration transducer); a static surround may be present or absent	Determine thresholds for vibration sensitivity under a variety of experimental conditions (e.g., different durations or intensities)
	Multi-channel systems of several contractors arranged as an array	Communicate an information-carrying pattern; e.g., the Optacon (Ref. 2), used as a reading aid for the blind, employs a 24 x 6 array of contractors to encode alphanumeric information

Applications

Designs to replace or augment a lost or overloaded sensory input channel, such as tactile aids for the hearing impaired, and optical-to-tactile converters for the blind (Ref. 2).

Key References

1. Bliss, J. C. (1974). Summary of three optacon-related cutaneous experiments. In F. Geldard (Ed.) *Cutaneous communication systems and devices*. Austin, TX: The Psychonomic Society.
2. Bliss, J. C., Katcher, M. H., Rogers, C. H., & Shepard, R. P. (1970). Optical-to-tactile image conversion for the blind. *IEEE Transactions on Man-Machine Systems, MMS-11*, 58-64.
3. Sherrick, C. E. (1965). Simple electromechanical vibration transducer. *Review of Scientific Instruments, 36*, 1893-1894.
4. Sherrick, C. E. (1975). The art of tactile communication. *American Psychologist, 30*, 353-360.

Cross References

- 3.101 Cutaneous sensitivity

3.106 Pressure and Vibration Sensitivity

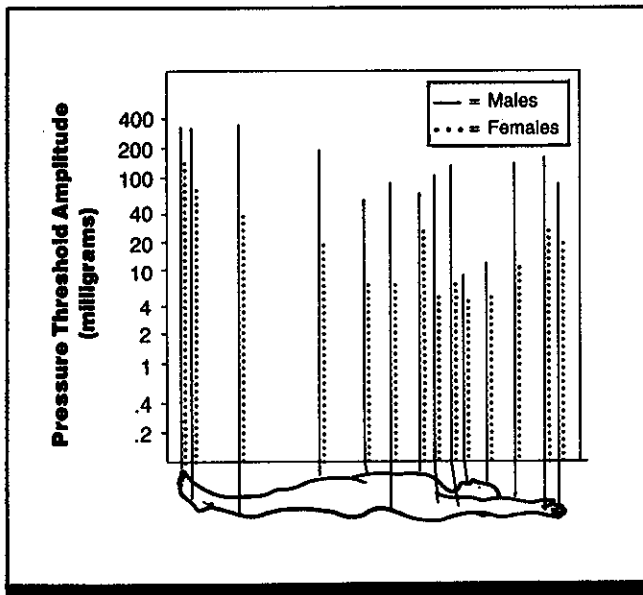

Figure 1. Average pressure thresholds for males (solid lines) and females (dotted lines). (Adapted from Ref. 1)

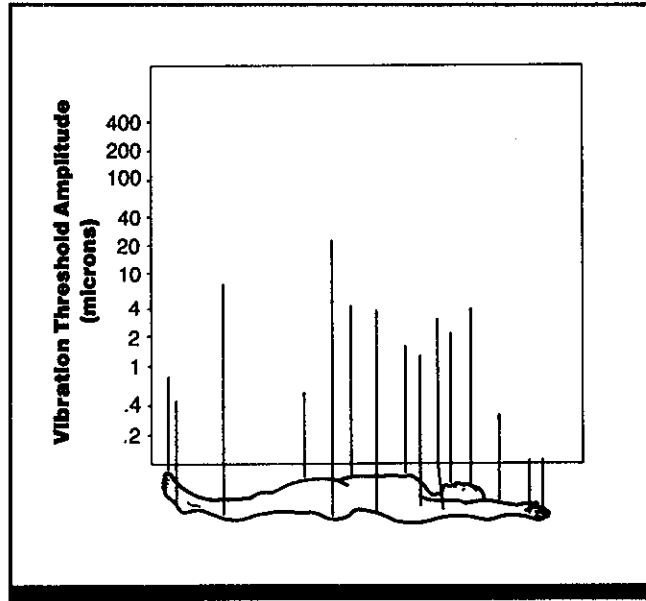

Figure 2. Thresholds for 200-Hz vibration for one male subject. (Based on data from Ref. 2)

Key Terms

Pressure sensitivity; tactile detection; touch; vibration sensitivity; vibrotactile stimulation

General Description

The sensitivity profiles across body sites for pressure and vibration are different. Sensitivity to pressure (minimum perceivable amplitude of pressure) is greatest on the face, followed by the trunk and fingers. Females (Fig. 1, dotted lines) are generally 0.4-0.6 log units more sensitive than

males (Fig. 1, solid lines). Sensitivity to vibration (minimum perceivable amplitude of vibration applied to the skin) is greatest on the hands and soles of the feet (Fig. 2).

It is remarkable that the profiles of sensitivity to pressure and to vibration over the body are not more alike, and suggests the operation of different underlying receptor mechanisms.

Applications

Designs incorporating tactile or vibrotactile signals. Determination of amount of pressure necessary to cause awareness of an event such as an accidental button press.

Methods

Test Conditions

Pressure (Ref. 1)

- Von Frey-type filaments (nylon monofilaments that bend at a calibrated force) applied to the skin
- Multiple body sites tested for both males and females (see Fig. 1); laterality (left and right sides) tested for each body site; means over both sides are shown in figure

- Six alternating ascending and descending series per site
- Subjects seated for above-waist tests and supine or prone for below-waist tests; hair at test sites cut off with scissors

Vibration (Ref. 2)

- 14 vibration frequencies from 25-1280 Hz delivered to a round skin contactor with 1-cm² area
- Multiple body sites tested (see Fig. 2)

- Because of apparatus noise (>200 Hz), subject's ears were stopped with wax

Experimental Procedure

Pressure

- Modified method of limits
- Independent variables: body site, sex, side of body
- Dependent variable: threshold (mean minimal perceived stimulus amplitude for six determinations)
- Subject's task: detect and report

stimulus presence (ascending series) or disappearance (descending series)

- 24 right-handed male and 24 right-handed female subjects

Vibration

- Independent variables: stimulus frequency of vibration, body site
- Dependent variable: threshold (mean minimal perceived stimulus amplitude for six determinations)
- 1 male subject

Experimental Results

Pressure Sensitivity

- Sensitivity to pressure is greatest on the face, followed by the trunk and fingers.
- Males and females have similar sensitivity profiles (rank-order correlation = 0.73, $p < 0.001$), but females are generally 0.4-0.6 log units more sensitive than males.
- The left side of the body is more sensitive than the right for all points but forehead, nose, breast, belly, and back.

Vibration Sensitivity

- The sensitivity profile for vibration differs from the profile for pressure.
- Sensitivity to vibration is greatest on the hands and the soles of the feet.

Constraints

- Cutaneous sensitivity may decrease when a subject performs simultaneous tasks involving touch, such as operating aircraft controls.
- Vibrotactile sensitivity varies with vibration frequency (Ref. 2; CRef. 3.108). Pressure and vibration sensitivity are also influenced by the size of the stimulated area, stimulus

Key References

*1. Weinstein, S. (1968). Intensive and extensive aspects of tactile sensitivity as a function of body part, sex, and laterality. In D. R. Kenshalo (Ed.), *The skin senses*

(pp. 195-222). Springfield, IL: Thomas.

*2. Wilska, A. (1954). On the vibrational sensitivity in different regions of the body surface. *Acta Physiologica Scandinavica*, 31, 285-289.

Cross References

3.105 Apparatus for static and vibratory (mechanical) stimulation of the skin;

3.107 Vibrotactile stimulation: detectability of tactile pulses of varying duration;

3.108 Vibrotactile stimulation: ef-

fect of frequency and type of spatial surround;

Variability

3.115 Tactile localization and two-point discrimination

Analysis of variance used for pressure sensitivity. Vibration data are comparable to those for two other male subjects of the same age. Vibration thresholds show daily variations by a factor of 5-10.

Repeatability/Comparison with Other Studies

Pressure-sensitivity profiles for two-point thresholds (minimum spatial separation necessary for two points to be judged as two points) and for stimulus localization task (accuracy of localizing a touch on the skin) are also available (CRef. 3.115).

duration, use of a stimulator with a static surround, and skin temperature (CRefs. 3.107, 3.108).

- Comparisons of pressure and vibration thresholds may not be informative because of differences in stimulus characteristics and in characteristics of the skin tested (e.g., smooth forehead versus calloused sole of foot).
- The vibration data are based on only one male subject and may not generalize to other males and to females.

3.107 Vibrotactile Stimulation: Detectability of Tactile Pulses of Varying Duration

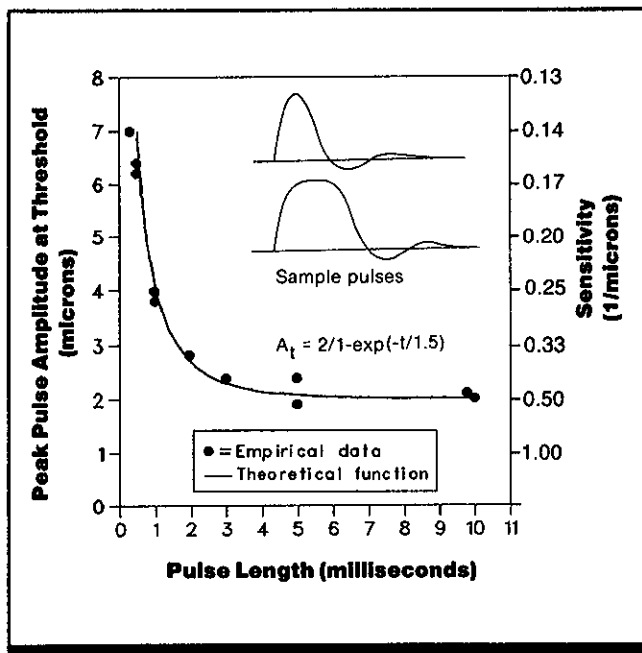

Figure 1. Threshold amplitude for pulses to the fingertip as a function of pulse duration. (From Ref. 1)

Key Terms

Pressure sensitivity; tactile detection; temporal summation; touch; vibration sensitivity; vibrotactile stimulation

General Description

Detectability of taps (rectangular vibrotactile pulses) to the fingertip increases exponentially (threshold amplitude decreases exponentially) as pulse duration increases from 110 msec. Thresholds are constant for pulse durations from 10-100 msec.

Applications

Design situations in which pulsatile rather than vibrotactile signals must be used, e.g., because of a need for a flat frequency response.

Methods

Test Conditions

- Pulses (taps) of 0.35-100 msec (0.2 msec rise-fall time) delivered to the fingertip by 0.64-mm (0.025-in.) diameter skin contactor seated

in a 2.3-mm (0.090-in.) hole of static surround (sample pulses shown in Fig. 1)

- Pulses presented at rate of two per sec
- Amplitude of pulse slowly increased until just perceived

Experimental Procedure

- Method of limits (ascending series only)
- Independent variable: stimulus duration

- Dependent variable: threshold amplitude (in μm)
- Subject's task: report when pulse stimulus could first be detected as amplitude was increased
- 1 subject

Experimental Results

- The displacement amplitude required to detect a tactile pulse (tap) decreases exponentially as the pulse duration increases from 1-10 msec. Threshold amplitude remains constant at 2 μm from 10-100 msec.
- The data are well fit by an exponential function of the form

$$A_t = 2\{1 - \exp(-t/1.5)\}$$

where A_t is the threshold amplitude in μm and t is pulse duration in msec. The equation models an integrator with a triggering threshold and a time constant of 1.5 msec.

Constraints

- Vibrotactile sensitivity is affected by the size of the stimulated area, the frequency of vibration, use of a stimulator with a static surround, body site of stimulation, and skin temperature (CRefs. 3.106, 3.108).
- Generalizability is restricted because only 1 subject was used to obtain the measurements.

Key References

*1. Hill, J. W. (1967). *The perception of multiple tactile stimuli* (Technical Report No. 4823-1). Palo Alto, CA: Stanford University, Electronics Laboratory.

2. Rothenberg, M., Verrillo, R. T., Zahorian, S. A., Brachman, M. L., & Bolanowski, S. J., Jr. (1977). Vibrotactile frequency for encoding a speech parameter. *Journal of the Acoustical Society of America*, 62, 1003-1012.

Cross References

3.105 Apparatus for static and vibratory (mechanical) stimulation of the skin;

3.106 Pressure and vibration sensitivity;

3.108 Vibrotactile stimulation: effect of frequency and type of spatial surround;

3.116 Vibrotactile stimulation: effect of adaptation on detectability and perceived magnitude;

3.125 Electrocutaneous stimulation: effect of exposure duration on sensitivity

- The function demonstrates the phenomenon of **temporal summation** at durations of <2 msec: Longer stimulus durations result in lower thresholds, to a point.

Variability

Thresholds at the same body locus were repeatable to within 10% on successive measurements.

Repeatability/Comparison with Other Studies

A similar function relating threshold intensity and stimulus duration is found for **electrocutaneous** stimuli (Ref. 1; CRef. 3.125).

3.108 Vibrotactile Stimulation: Effect of Frequency and Type of Spatial Surround

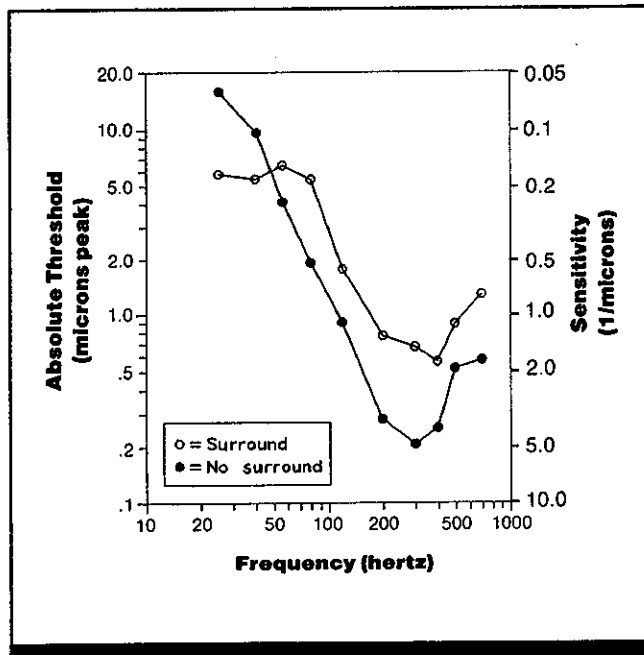

Figure 1. Absolute vibrotactile thresholds at the base of the thumb for different stimulus frequencies with a static surround either present or absent. (From *Handbook of perception and human performance*, adapted from Ref. 1)

Key Terms

Pressure sensitivity; spatial interaction; tactile detection; touch; vibration sensitivity; vibrotactile stimulation

General Description

Sensitivity to vibrotactile stimuli varies with vibration frequency. Lowest threshold (i.e., greatest sensitivity) is found for stimuli of ~200-400 Hz. Sensitivity to a vibrotactile stimulus is generally greatest when a static surround is not used (except at frequencies below 40-50 Hz, where sensitivity is less for some stimulus diameters).

Methods

Test Conditions

- 1-sec vibrotactile bursts with 100-msec rise-fall time delivered by a 5-mm diameter (0.2 cm²) contactor depressed 1 mm into the skin of the base of the thumb (thenar eminence) of the right hand
- Support table had a 7-mm diameter hole (1-mm gap around contactor) for surround condition and a

60-mm diameter hole (27.5-mm gap) for no-surround condition

- Continuous train of 1-sec-on/1-sec-off stimulus presentations with stimulus intensity changing in steps of 1 dB re 1.0 μm displacement per sec at each presentation
- Ten stimulus frequencies between 25 and 700 Hz

Experimental Procedure

- Method of adjustment with con-

tinuous threshold tracking (intensity lowered until the signal disappears, then raised until it reappears; adjustments made continuously around threshold); trials blocked by surround conditions and by stimulus frequency

- Independent variables: stimulus frequency, presence or absence of a static surround
- Dependent variable: threshold

(mean stimulus intensity for three 1-2 min periods of threshold tracking)

- Subject's task: increase or decrease stimulus intensity until sensation appears or disappears
- Subjects in isolation booth heard narrow-band noise (centered around stimulus frequency) through earphones
- 5 well-trained subjects

Experimental Results

- Sensitivity to a vibrotactile stimulus varies with stimulus frequency. Sensitivity is greatest between 200 and 400 Hz.
- The presence of a static surround generally reduces sensitivity by ~6-8 dB (re 1.0 μm peak displacement). At frequencies of 50 Hz or less, however, a surround improves sensitivity (lowers threshold) with a contactor of 5-mm diameter.

Constraints

- Results may vary considerably with different experimental conditions and methodological procedures. For example, removal of the surround from a 3.0-cm² contactor has little effect on threshold values.

Key References

*1. Gescheider, G. A., Capraro, A. J., Frisina, R. D., Hamer, R. D., & Verrillo, R. T. (1978). The effects of a surround on vibrotactile thresholds. *Sensory Processes*, 2, 99-115.

2. Verrillo, R. T. (1968). A duplex mechanism of mechanoreception. In D. R. Kenshalo (Ed.), *The skin senses* (pp. 139-159). Springfield, IL: Thomas.

Cross References

3.105 Apparatus for static and vibratory (mechanical) stimulation of the skin;

3.106 Pressure and vibration sensitivity;

3.107 Vibrotactile stimulation: detectability of tactile pulses of varying duration;

Variability

Standard errors of the mean range from 1-3 dB across frequencies.

Repeatability/Comparison with Other Studies

Reference 1 cites comparable results from other studies. Similar data were reported in Ref. 2, which also presents comparable results for the forearm and tongue.

- Small contactor sizes (<1.0-mm diameter) produce a threshold that is high (~5-10 μm peak) and nearly constant across frequencies.

- Vibrotactile sensitivity is affected by the body site stimulated, stimulus duration, and skin temperature (CRefs. 3.106, 3.107).

3.110 Vibrotactile stimulation: detectability of intensity differences in the presence of spatial masking;

Handbook of perception and human performance, Ch. 12, Sect. 4.3

3.109 Vibrotactile Stimulation: Detectability of Intensity Differences

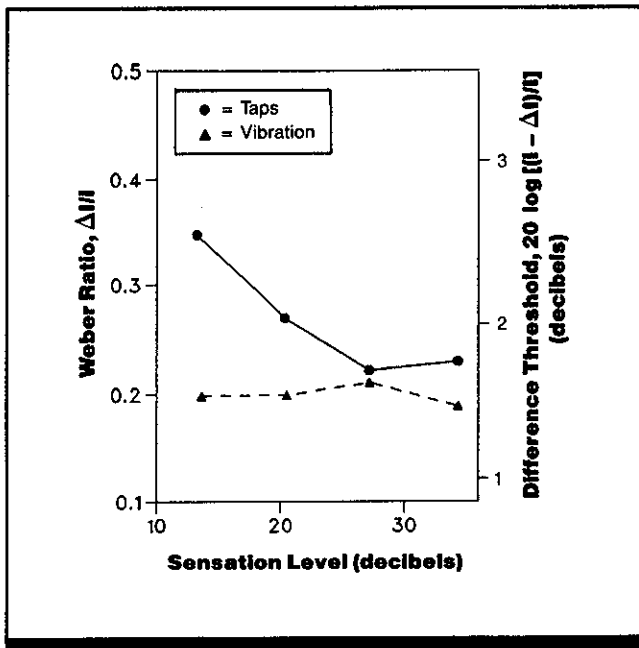

Figure 1. Relative discriminability of intensity differences for taps and vibrotactile stimulation of the skin as a function of stimulus intensity. I = stimulus intensity; ΔI = smallest detectable intensity difference. (From *Handbook of perception and human performance*, after Ref. 1)

Key Terms

Pressure sensitivity; tactile discrimination; touch; vibration sensitivity; vibrotactile stimulation

General Description

The ability to detect a difference in intensity (ΔI) between two vibrotactile stimuli is essentially constant across a range of stimulus amplitudes from 14-35 dB above threshold. In contrast, detectability of a difference in intensity between two taps decreases with decreasing amplitude of the taps.

Methods

Test Conditions

- Vibrotactile stimuli were 160-Hz bursts lasting 200 msec with 10-msec rise time; taps were 2-msec square-wave pulses
- Stimuli delivered by a 6-mm diameter skin contactor at intensities of 14-35 dB above threshold for each stimulus

- Stimuli presented to right index finger; standard and comparison signals presented 1 sec apart

Experimental Procedure

- Block up-and-down method for two-interval forced-choice procedure in which previous and current

response relationship determines whether difference between stimuli is increased or decreased on next trial

- Independent variables: type of stimulus, intensity of standard stimulus
- Dependent variable: difference threshold in decibels (defined as $20 \log \{(I - \Delta I)/I\}$; also plotted as Weber ratio $[\Delta I/I]$)

- Subject's task: indicate which of two sequential stimuli is more intense; feedback provided on each trial

- ~100 trials per difference threshold; 10 difference-threshold measurements
- 2 female undergraduates with extensive practice

Experimental Results

- The ability to detect a difference in intensity between two vibrotactile stimuli is essentially constant across intensity levels of 14-35 dB above absolute threshold. The stimuli must differ in intensity by ~20% (Weber ratio of 0.20) to be reliably discriminated.
- The ability to detect a difference in intensity between two taps decreases (difference threshold increases) at lower intensities; at higher intensities, the ability to detect a differ-

ence in intensity is approximately the same as for vibrotactile stimuli.

Variability

No information on variability was given.

Repeatability/Comparison with Other Studies

The 20% difference threshold for vibrotactile stimuli is similar to the difference thresholds for step changes of pressure.

Constraints

- Because a number of factors (such as contactor size and level of static force) can affect the energy delivered to the skin, values obtained are difficult to compare to those obtained by other methods of measurement.

- Results should not be generalized to intensities <15 dB, where the difference threshold for vibrotactile stimuli rises sharply with increasing intensity.
- Because stimulus levels are defined *with reference to threshold*, the fact that vibrotactile thresholds vary across the body *may* not affect the shape of this function.

Key References

*1. Craig, J. C. (1963). Difference threshold for intensity of tactile stimuli. *Perception & Psychophysics*, 11, 150-152.

Cross References

3.105 Apparatus for static and vibratory (mechanical) stimulation of the skin;

3.106 Pressure and vibration sensitivity;

3.110 Vibrotactile stimulation: detectability of intensity differences in the presence of spatial masking

3.110 Vibrotactile Stimulation: Detectability of Intensity Differences in the Presence of Spatial Masking

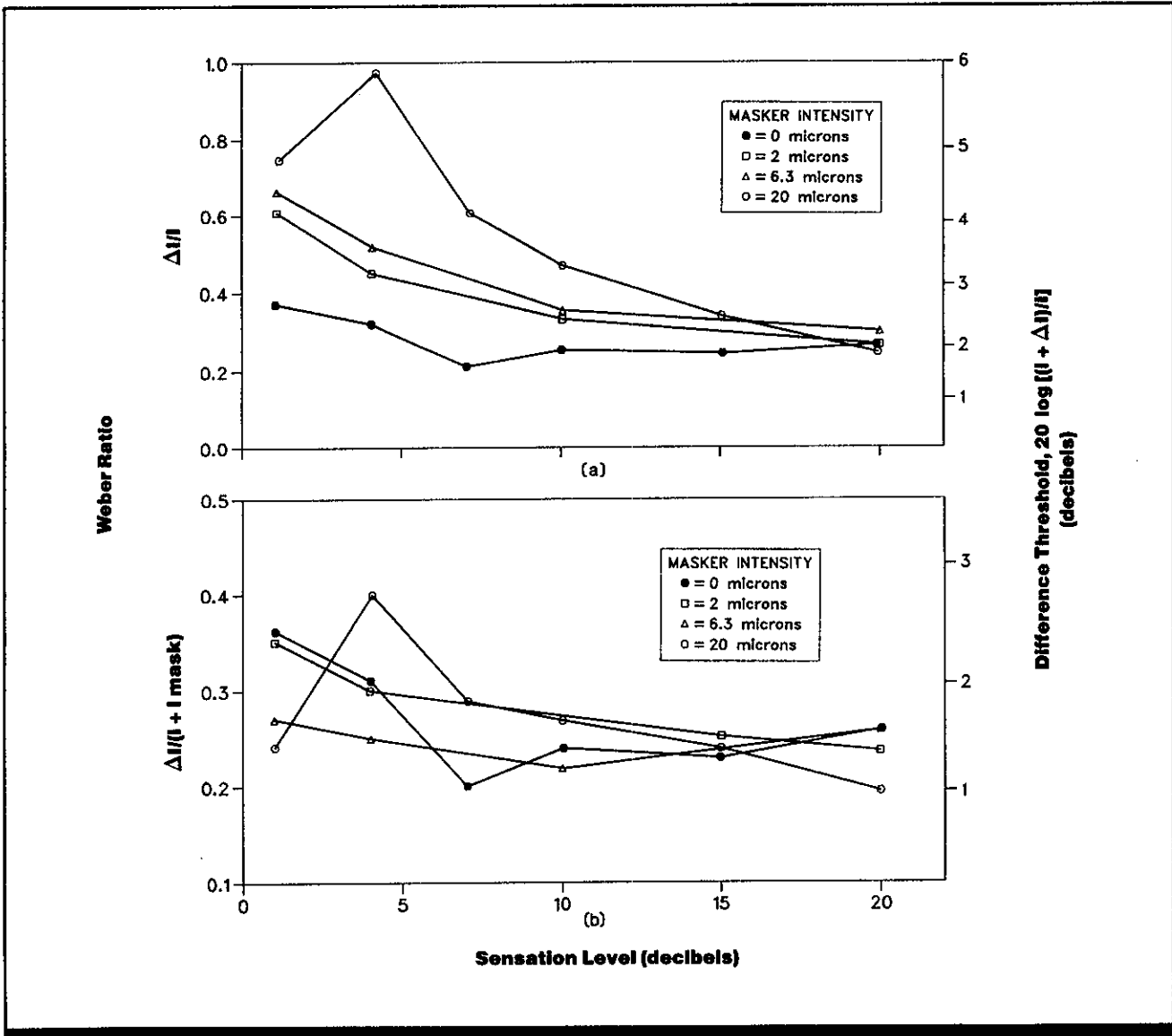

Figure 1. Vibrotactile difference thresholds for intensity expressed as Weber ratios (left axis) or as number of decibels above threshold (right axis) with or without mask. The Weber ratios ($\Delta I/I$) in Fig. 1a are calculated normally without considering mask intensity. The corresponding functions in Fig. 1b are plotted with the mask intensity included in the baseline ($\Delta I/(I + I_{mask})$). The horizontal axis shows the baseline intensity (intensity level from which a change in intensity had to be discriminated) in decibels above absolute threshold, measured with (open symbols) or without (filled symbols) a masking stimulus present. (From Ref. 2)

Key Terms

Pressure sensitivity; stimulus interaction; tactile discrimination; tactile masking; touch; vibration sensitivity; vibrotactile stimulation

General Description

When a subject must detect a difference in intensity between two **vibrotactile** stimuli delivered to the same body site, the difference threshold (smallest detectable change in intensity) increases when a **masking** stimulus is presented simultaneously to a nearby body site. The difference threshold as a proportion of baseline intensity with which the in-

tensity change is being compared (sometimes called the Weber ratio) increases as the intensity of the masking stimulus increases. However, when the difference threshold is considered as a proportion of baseline stimulus intensity plus effective mask intensity, the effect of masking is eliminated. The intensity difference threshold decreases in proportional size (discriminability increases) as baseline intensity increases.

Methods

Test Conditions

- Both test stimuli and mask were 160-Hz bursts lasting 200 msec with 10-msec rise time delivered by 6-mm diameter skin contactors
- Contactors rested on the finger with static force of 20 gm inside 8-mm hole of fixed surround
- Test stimuli presented to right index finger at six baseline intensities from 1-20 dB above masked threshold (absolute threshold with masking stimulus present); mask-

ing stimulus presented to right little finger simultaneously at amplitudes of 2.0, 6.3, or 20 μm

- Two 1-sec observation intervals per trial; test stimuli of two different intensities presented, one in each interval; in masking conditions, masking stimulus presented in each interval simultaneously with test stimuli; intensity of one test stimulus held constant during session at baseline of 1, 4, 7, 10, 15, or 20 dB above threshold, intensity of other stimulus varied in 0.3-dB steps

Experimental Procedure

- Block up and down method for two-alternative forced-choice procedure in which previous and current response relationship determines whether difference between stimuli is increased or decreased on next trial
- Independent variables: baseline test stimulus intensity (I); mask intensity (I_{mask})
- Dependent variable: smallest intensity difference detectable on 75% of trials (ΔI , difference threshold); data are plotted in terms

of relative discriminability, defined as Weber ratio ($\Delta I/I$) and ratio adjusted to include intensity of mask ($\Delta I/(I + I_{\text{mask}})$); data also plotted as difference threshold in decibels ($20 \log [I + \Delta I]/I$)

- Subject's task: indicate which of two observation intervals contains the more intense target stimulus
- 100 trials per observation; 7-21 observations per data point, depending on masking condition
- 1 male and 2 female college students with some practice

Experimental Results

- Discriminability of a difference in intensity between two vibrotactile stimuli presented successively to the index finger decreases (difference threshold increases) with increasing intensity of a masking stimulus presented simultaneously to the little finger (Fig. 1a).
- The amplitude of the masking stimulus has a progressively smaller effect as the baseline intensity of the test stimulus (i.e., intensity from which a change must be discriminated) increases, and is negligible at a baseline intensity of 20 dB above threshold (Fig. 1a).
- When the discriminability of an intensity change is calcu-

lated not in relation to the baseline intensity of the test stimulus alone but in relation to the baseline intensity of the test stimulus plus the effective intensity of a simultaneous mask ($\Delta I/(I + I_{\text{mask}})$), the functions for different mask intensities are more similar to each other (Fig. 1b) than when the mask intensity is not added to the baseline (Fig. 1a).

Variability

Standard errors of the means range between 0.1 and 0.4 dB.

Repeatability/Comparison with Other Studies

Similar results are reported in Ref. 1. Reference 3 reports comparable data for auditory stimuli.

Constraints

- Discriminability of intensity differences can vary with body site and with the interval between presentation of target and mask (CRef. 3.117).

Key References

1. Craig, J. C. (1972). Difference threshold for intensity of tactile stimuli. *Perception & Psychophysics*, 11, 150-152.

*2. Craig, J. C. (1974). Vibrotactile difference thresholds for intensity and the effect of a masking stimulus. *Perception & Psychophysics*, 15, 123-127.

3. Sherrick, C. E. (1959). Effect of background noise on the auditory intensive difference limen. *Journal of the Acoustical Society of America*, 31, 239-242.

Cross References

3.105 Apparatus for static and vibratory (mechanical) stimulation of the skin;

3.109 Vibrotactile stimulation: de-

tectability of intensity differences;

3.117 Vibrotactile stimulation: detectability in the presence of masking;

Handbook of perception and human performance, Ch. 12, Sect. 4.3

3.111 Vibrotactile Stimulation: Perceived Magnitude

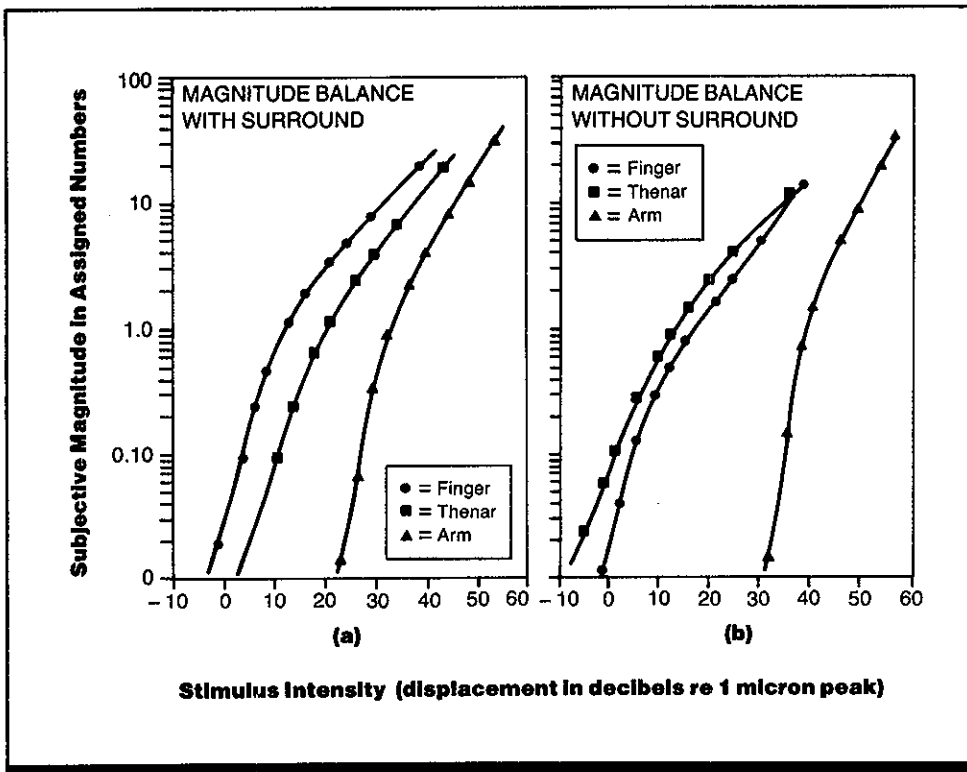

Figure 1. Perceived magnitude of vibratory stimulation (measured in terms of assigned numbers) as a function of stimulus intensity (a) with static surround and (b) without static surround for finger pad, base of thumb (thenar eminence), and arm. (From Ref. 2)

Key Terms

Pressure sensitivity; tactile sensation magnitude; touch; vibration sensitivity; vibrotactile stimulation

General Description

The perceived magnitude of a **vibrotactile** stimulus increases with increasing stimulus intensity. The slope of this function varies with the site of stimulation and the presence or absence of a static surround.

Applications

Data are of particular importance in applications where *changes* in the perceived intensity of a vibrotactile stimulus must be encoded, because these changes are determined by the slopes of the functions shown.

Methods**Test Conditions**

- 250-Hz bursts lasting 900 msec delivered to 6-mm diameter (0.23 cm² area) contactor indented 0.5 mm into skin
- Contactor positioned at base of thumb (thenar eminence), outermost pad of right middle finger, or inner forearm

- Contactor had static surround with 8-mm diameter hole
- Ten different stimulus intensities presented

Experimental Procedure

- Method of numerical magnitude balance (nonnormalized combination of method of magnitude estimation and method of magnitude production); stimulus order randomized separately for each of three series of stimulus intensities or numbers

- Independent variables: stimulation site, stimulus intensity, presence or absence of static surround
- Dependent variable: perceived magnitude of stimulus, measured by numbers assigned by subject to ten different stimulus intensities (no reference standard presented) for magnitude estimation, or by intensity of stimulus set by subject to match numbers presented by experimenter for magnitude production;

- combined results of procedures averaged to produce magnitude balance function plotted in figure
- Subject's task: to assign numbers to different stimulus intensities (magnitude estimation), or to set stimulus intensities to match designated numbers (magnitude production), in proportion to their perceived magnitudes
 - Data from first series discarded; data from second and third series averaged for each subject
 - 9 subjects, some practice

Experimental Results

- The subjective magnitude of a vibrotactile stimulus increases with increasing stimulus intensity.
- The slope of the upper arm of this function varies with site of stimulation and presence or absence of static surround. The presence of a static surround increases the slopes for finger (0.42 to 0.45) and base of thumb (0.40 to 0.50), but decreases the slope for arm (0.77 to 0.65).

Variability

No information on variability was given. Other studies indicate that the standard deviation of the mean can range from 3-10 dB as stimulus intensity increases for magnitude estimation and from 3-8 dB for magnitude production (Ref. 3).

Repeatability/Comparison with Other Studies

Similar results were found by Stevens (Ref. 1) for a 60-Hz stimulus presented to the arm.

Constraints

- Many factors, such as stimulus duration, size of area stimulated, number of vibrators, presence of another stimulus in close spatial or temporal proximity, and sensory adaptation, influence the apparent magnitude of a vibrotactile stimulus and should be considered in applying these results under different conditions (CRefs. 3.112, 3.113, 3.114).

- The upper portion of the curves may be most representative of the system's operation because the lower (steeper) portion of the curves probably reflects near threshold properties.
- The growth of subjective magnitude will vary at other body sites, possibly as a function of the density and number of receptors activated by the stimulus.

Key References

1. Stevens, S. S. (1959). Tactile vibration: Dynamics of sensory intensity. *Journal of Experimental Psychology*, 57, 210-218.

*2. Verrillo, R. T., & Chamberlain, S. C. (1972). The effect of neural density and contactor surround on vibrotactile sensation magnitude. *Perception & Psychophysics*, 11, 117-120.

3. Verrillo, R. T., Fraioli, A. J., & Smith, R. L. (1969). Sensation magnitude of vibrotactile stimuli. *Perception & Psychophysics*, 18, 128-136.

Cross References

3.105 Apparatus for static and vibratory (mechanical) stimulation of the skin;

3.112 Vibrotactile stimulation: per-

ceived magnitude as a function of number of active vibrators;

3.113 Vibrotactile stimulation: summation of perceived magnitude;

3.114 Vibrotactile stimulation: enhancement of perceived magnitude

3.112 Vibrotactile Stimulation: Perceived Magnitude as a Function of Number of Active Vibrators

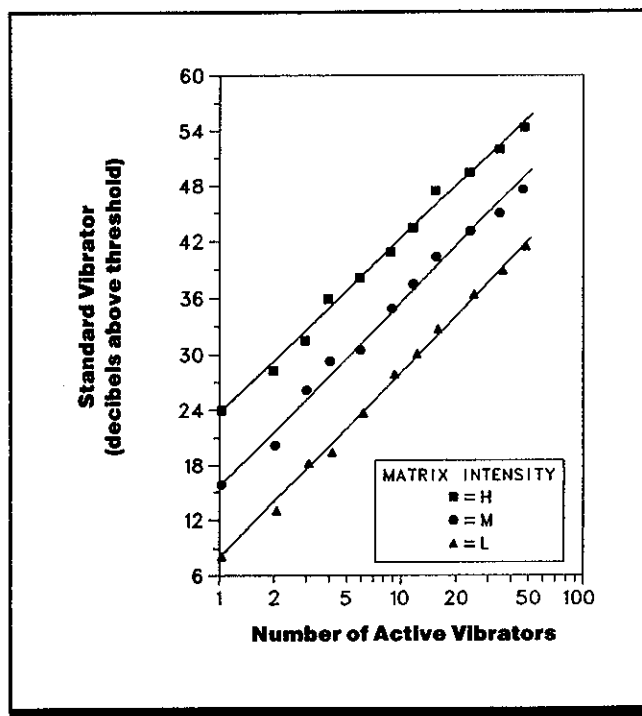

Figure 1. Perceived magnitude of a vibrotactile pattern (measured in terms of magnitude of standard adjusted to match pattern in apparent intensity) as a function of the number of vibrating contactors in an 8 x 8 matrix. *H* indicates stimulus intensity of 202 μm ; *M* indicates 136 μm ; *L* indicates 92 μm . (From Ref. 1)

Key Terms

Spatial summation; tactile sensation magnitude; touch; vibration sensitivity; vibrotactile stimulation

General Description

The perceived magnitude of a vibrotactile pattern increases with an increase in the number of active vibrators comprising the pattern. The rate of growth in perceived magnitude is independent of stimulus intensity.

Methods

Test Conditions

- 64 5-mm diameter (0.2 cm²) skin contactors rested with average static force of 10 gm on 15-mm centers of 8 x 8 matrix
- Vibrotactile matrix positioned on left front thigh of seated subject

- 1-49 contactors energized at 250 Hz for 200 msec at three intensity levels (*L* = 92 μm ; *M* = 136 μm ; *H* = 202 μm) in a square or almost square pattern
- Standard contactor positioned on left middle finger and activated by a 200-Hz, 200-msec signal alternating with the matrix stimulus at an interstimulus interval of 500 msec

Experimental Procedure

- Method of adjustment; trials blocked by number of active contactors with 2 sec between blocks
- Independent variables: number of vibrators in pattern matrix, stimulus intensity
- Dependent variable: apparent magnitude of pattern matrix, measured as intensity of standard con-

- tactor (in dB above threshold) required to match perceived intensity of pattern matrix
- Subject's task: adjust intensity of standard contactor until it appeared equal to intensity of pattern matrix
- 60 trials per data point per subject
- 4 experienced male subjects

Experimental Results

- Perceived magnitude of a vibrotactile array (in decibels above threshold) increases linearly with the logarithm of the number of active vibrators comprising the pattern.
- The straight lines in Fig. 1 were fit to the data for each intensity level by the method of least squares. The slopes of

the functions are parallel for different vibration amplitudes of the vibrotactile matrix.

Variability

Standard errors of the mean are <2 dB for each intensity for the 16-vibrator matches.

Constraints

- Many factors, such as body site, stimulus duration, size of area stimulated, use of vibrator with a static surround, presence of another stimulus in close spatial or temporal proximity, and sensory adaptation, influence the apparent

magnitude of a vibrotactile stimulus and should be considered in applying these data under different conditions (CRefs. 3.111, 3.113, 3.114).

- Stimulation frequencies of <40 Hz yield functions with much shallower slopes.

Key References

*1. Cholewiak, R. W. (1979). Spatial factors in the perceived intensity of vibrotactile patterns. *Sensory Processes*, 3, 141-156.

2. Gescheider, G. A., & Wright, J. H. (1968). Effects of sensory adaptation on the form of the psychophysical magnitude function for cutaneous vibration. *Journal of Experimental Psychology*, 77, 308-313.

Cross References

3.105 Apparatus for static and vibratory (mechanical) stimulation of the skin;

3.111 Vibrotactile stimulation: perceived magnitude;

3.113 Vibrotactile stimulation: summation of perceived magnitude;

3.114 Vibrotactile stimulation: enhancement of perceived magnitude

3.113 Vibrotactile Stimulation: Summation of Perceived Magnitude

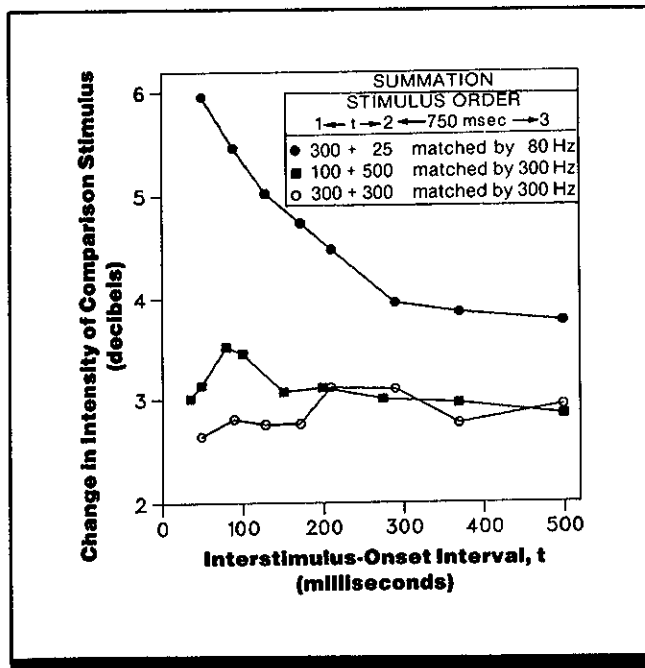

Figure 1. Summation of perceived overall magnitude of a pair of vibrotactile stimuli as a function of the interstimulus-onset interval between the two stimuli. Subjects were instructed to match the magnitude of a comparison stimulus to the overall magnitude of the pair. Magnitude summation is measured as the difference (in dB) between the intensity of the comparison stimulus required for this match and the intensity required to match the second member of the pair presented alone. (From Ref. 1)

Key Terms

Magnitude summation; stimulus interaction; tactile sensation magnitude; touch; vibration sensitivity; vibrotactile stimulation

General Description

When two vibrotactile stimuli are presented in close temporal succession, the perceived overall magnitude of the pair (i.e., amount of magnitude summation) is dependent on the relative frequencies of the two stimuli. Summation is greater when one frequency is higher than ~40 Hz and one

is less than ~40 Hz than when both frequencies are higher than or less than ~40 Hz. The effect decreases as interstimulus-onset interval increases for very different frequencies, but the effect is relatively independent of the interstimulus-onset interval when the two frequencies are close together.

Methods

Test Conditions

- 25-500 Hz vibrotactile bursts lasting 20 msec with 25-msec rise-fall time delivered via 19-mm diameter (2.9 cm²) contactor pressed 0.5 mm into skin of base of thumb (thenar eminence)
- Contactor centered in 21-mm hole of static surround
- Second stimulus set at sensation level of 24 dB re threshold and first

stimulus equated to the same subjective level

- Interval from onset of first stimulus to onset of second stimulus varied from 35-500 msec over trials in random order
- Comparison stimulus (80 Hz or 300 Hz) presented 750 msec after second stimulus

Experimental Procedure

- Method of limits for threshold determination; method of bracketing for summation, in which

subjects adjusted the intensity (perceived magnitude) of the comparison stimulus to match the upper and lower limits of the overall perceived magnitude of the pair, and then matched to the center of that delimited interval

- Independent variables: frequencies of first, second, and comparison stimuli; interstimulus-onset interval
- Dependent variable: magnitude summation of stimulus pair, measured as intensity difference (in dB)

between matched setting of the comparison stimulus to the overall magnitude of the stimulus pair and its matched setting to the second stimulus of pair presented alone

- Subject's task: match the perceived magnitude of the comparison stimulus to the overall magnitude of the stimulus pair
- Subjects in isolation booth with narrow-band noise (centered around stimulus frequency)
- Two to six trials per condition
- 5 well-trained subjects

Experimental Results

- The perceived overall magnitude of a pair of successively presented vibrotactile stimuli is greater when one frequency is higher than and one lower than ~40 Hz than when both frequencies are higher or both lower than ~40 Hz.
- When the two frequencies are very different, the effect decreases as the interstimulus-onset interval increases. The effect is relatively independent of the interstimulus onset interval when both frequencies are above or both below ~40 Hz.
- Duration of interstimulus interval effects and frequency of the stimulus pair effects were negated when the fre-

quency of the comparison stimulus was similar to one of the stimulus pair's frequencies. Subjects tended, in direct contradiction to the experimenter's instructions, to match the comparison stimulus to the stimulus more similar in frequency rather than matching to either the combined magnitudes of the stimulus pair or to one of the stimulus pair.

Variability

Standard deviations of the means ranged between 0.09 and 1.88 dB.

Repeatability/Comparison with Other Studies

Similar results are found for auditory stimuli (Ref. 2).

Constraints

- Many factors, such as body site, stimulus duration, size of area stimulated, number of vibrators, use of vibrator with a static surround versus no surround, presence of another stimulus in close spatial or temporal proximity, and sensory

adaptation, may affect the apparent magnitude of vibrotactile stimuli and should be considered in applying these results under different conditions (CRefs. 3.111, 3.112, 3.114).

Key References

*1. Verrillo, R. T., & Gescheider, G. A. (1975). Enhancement and summation in the perception of two successive vibrotactile stimuli. *Perception & Psychophysics*, 18, 128-136.

2. Zwisllocki, J. J., & Ketkar, I. (1972). Loudness enhancement and summation in pairs of short sound bursts. *Journal of the Acoustical Society of America*, 51, 140.

Cross References

2.604 Effect of bandwidth on the loudness of two-tone complexes;

3.111 Vibrotactile stimulation: perceived magnitude;

3.112 Vibrotactile stimulation: perceived magnitude as a function of number of active vibrators;

3.114 Vibrotactile stimulation: enhancement of perceived magnitude

3.114 Vibrotactile Stimulation: Enhancement of Perceived Magnitude

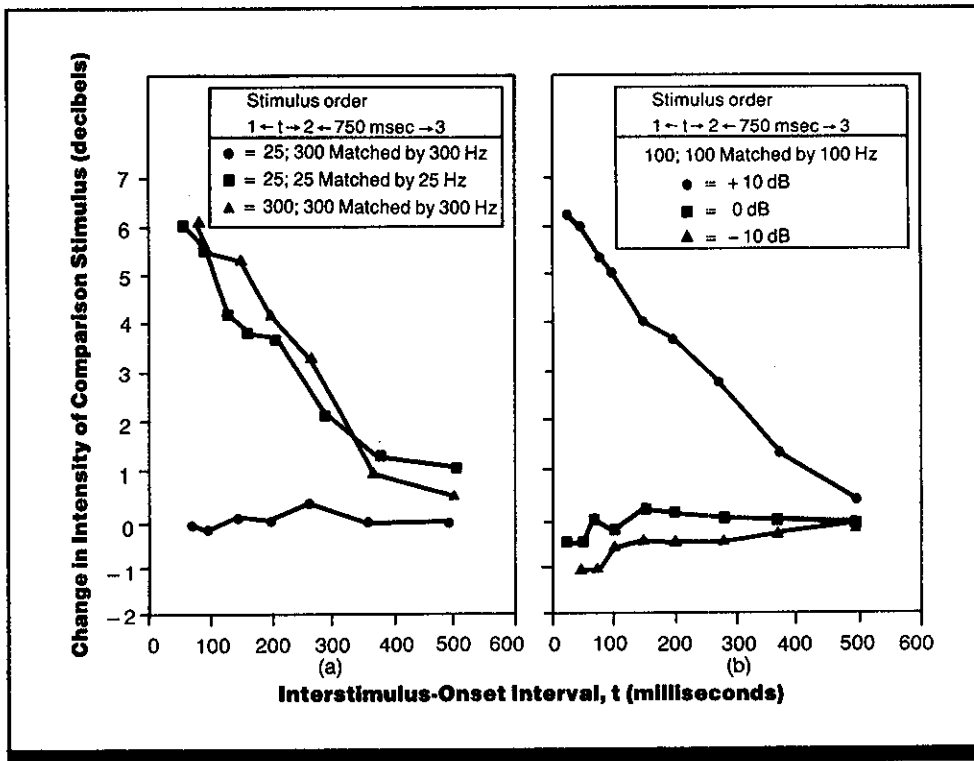

Figure 1. Change in perceived magnitude of the second of a pair of vibrotactile stimuli as a function of interstimulus-onset interval. (a) Effect of frequency differences; the first stimulus of the pair is 10 dB more intense than the second stimulus. (b) Effect of intensity differences; the relative intensity of the first stimulus is -10 dB, 0, or +10 dB as shown in the figure legend. Subjects were instructed to match the magnitude of a comparison stimulus to the magnitude of the second stimulus of the pair. Magnitude enhancement (positive values of the vertical axis) and reduction (negative values) are measured as the difference (in dB) between the intensity of the comparison stimulus required for this match and the intensity required to match the second member of the pair presented in isolation. (From Ref. 1)

Key Terms

Magnitude enhancement; stimulus interaction; tactile sensation magnitude; touch; vibration sensitivity; vibrotactile stimulation

General Description

When two vibrotactile stimuli are presented in close temporal succession, the perceived magnitude of the second stimulus may be enhanced, depending on the relative amplitudes and frequencies of the two stimuli. If the first stimulus is more intense than the second stimulus and both frequencies are greater than or less than ~40 Hz, enhancement is maximized. Enhancement decreases as the interstimulus-onset interval increases. The effect disappears if the two

frequencies differ considerably (e.g., 25 Hz and 300 Hz as shown in Fig. 1a).

In contrast, if the first stimulus is weaker than the second, there is a slight reduction in the judged magnitude of the second stimulus (Fig. 1b); the size of the reduction decreases as the interstimulus-onset interval increases. There is no effect (either enhancement or reduction) if the intensities of the two stimuli are equal (Fig. 1b).

Methods

Test Conditions

- 20 msec of vibration (25-300 Hz) with 25-msec rise/fall time delivered via 19-mm diameter contactor pressed 0.5 mm into skin at base of thumb (thenar eminence)
- Contactor centered in 21-mm hole of a static surround
- Second stimulus set at sensation level of 24 dB re threshold; first stimulus set at 10 dB above second stimulus, at the same subjective

level, or at 10 dB below second stimulus

- Time between onsets of first and second stimuli (interstimulus-onset interval) varied from 35-500 msec in random order
- Comparison (third) stimulus presented 750 msec following second stimulus at 25-300 Hz

Experimental Procedure

- Method of limits for baseline threshold determination; method of

bracketing for enhancement in which subjects adjusted the intensity of the comparison stimulus to match the upper and lower limits of the second stimulus in perceived magnitude, and then matched to the center of that delimited interval

- Independent variables: frequencies of first, second, and comparison stimuli; interstimulus-onset interval

- Dependent variable: enhancement or reduction of perceived magnitude as measured by intensity difference (in dB) between matched settings of the comparison stimulus to the second stimulus (when following the first stimulus and presented alone)
- Subject's task: match the perceived magnitude of the comparison stimulus to that of the second stimulus
- Two to six trials per condition
- 6 well-trained subjects

Experimental Results

- The perceived magnitude of the second member of a successively presented pair of vibrotactile stimuli is enhanced relative to its magnitude when presented alone if the first stimulus is greater in intensity than the second stimulus. If the first stimulus is weaker than the second, there is some reduction in the perceived magnitude of the second stimulus.
- These effects decrease as the interstimulus-onset interval increases.
- There is no enhancement or reduction when the two stimuli have equal intensities, or when the frequencies of the

two stimuli are very different (i.e., one stimulus is less than ~40 Hz and the other is greater than ~40 Hz).

Variability

Standard deviations of the means at each interstimulus interval range between 0.09 and 0.88 dB. Variability decreases as interstimulus-onset intervals increase.

Repeatability/Comparison with Other Studies

Results for stimulating different loci are reported in Ref. 2, and the effects of the second stimulus on the first in Ref. 3. Similar results for auditory stimuli are reported in Ref. 4.

Constraints

- The subjects often matched the comparison stimulus to the most perceptually similar portion of stimulus pair even when instructed to match to the second stimulus. Thus the characteristics of the comparison stimulus can influence the results.

- The first stimulus can act to mask (inhibit) the second if presented at a different body site (Ref. 2).
- Many factors, such as stimulus duration, size of area stimulated, number of vibrators, use of vibrator with a static surround, and sensory adaptation, influence the apparent magnitude of vibrotactile stimuli and should be considered in applying these results under different conditions. (CRefs. 3.111, 3.112, 3.113)

Key References

*1. Verrillo, R. T., & Gescheider, G. A. (1975). Enhancement and summation in the perception of two successive vibrotactile stimuli. *Perception & Psychophysics*, 18, 128-236.

2. Verrillo, R. T., & Gescheider, G. A. (1976). Effect of double ipsilateral stimulation on vibrotactile sensation magnitude. *Sensory Processes*, 1, 127-237.

3. Verrillo, R. T., & Gescheider, G. A. (1979). Backward enhancement and suppression of vibrotactile sensation. *Sensory Processes*, 3, 249-260.

4. Zwislocki, J. J., & Ketkar, I. (1972). Loudness enhancement and summation in pairs of short sound bursts. *Journal of the Acoustical Society of America*, 51, 140.

Cross References

3.105 Apparatus for static and vibratory (mechanical) stimulation of the skin;

3.111 Vibrotactile stimulation: perceived magnitude;

3.112 Vibrotactile stimulation: perceived magnitude as a function of number of active vibrators;

3.113 Vibrotactile stimulation: summation of perceived magnitude

3.115 Tactile Localization and Two-Point Discrimination

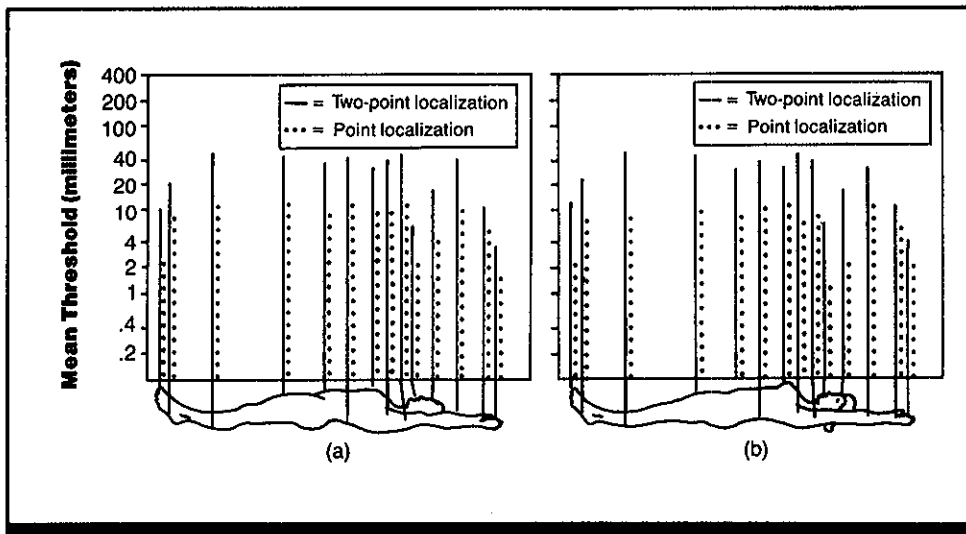

Figure 1. Mean threshold for two-point discrimination and point localization as a function of body site for (a) males and (b) females averaged across left and right sides of body. (Adapted from Ref. 4)

Key Terms

Pressure sensitivity; tactile acuity; tactile localization; tactile resolution; touch; two-point threshold

General Description

The ability to detect a separation between two points of tactile stimulation (two-point threshold) and the ability to identify the position of a tactile stimulus (tactile localization) are

highly correlated with each other, but vary across body sites. Results for males and females are highly correlated and the fingers, face, and toes are generally the most sensitive body sites.

Applications

Designs in which the loci of multiple stimuli must be separately perceived.

Methods

Test Conditions

- Double (two-point) stimuli delivered by machinist's calipers with two points that could be separated by 1-120 mm; single stimuli delivered by one point with a surface area equal to the sum (3.2 mm²) of the two points
- For point localization, reference point presented to center of Y-shaped grid stamped on skin (arms of Y diverging at 120 deg, tail oriented toward body); comparison points presented in series toward

and away from reference point along each of three arms of Y-shaped grid; points delivered by 3.2-mm² tip

- For two-point thresholds, six series per site, alternating ascending and descending series, with two double and two single stimulations presented randomly at each separation; thresholds always determined along longitudinal axis
- For both measures, separation of points change in 1-mm steps for face and fingers; 2.5-mm steps for all other body sites

- Multiple body sites tested for both males and females (see Fig. 1); both left and right sides of body tested for each site
- Subjects seated for above-waist tests and supine or prone for below-waist tests; hair at test sites cut off with scissors

Experimental Procedure

- Method of limits
- Independent variables: body site, type of threshold, sex, side of body
- Dependent variables: two-point threshold, define as average minimum distance between two points

that can be detected as two points; error of localization, defined as the average distance of most distant point identified as occurring at the reference point

- Subject's task: indicate if two points of stimulation are double or single stimulation; indicate if a single point of stimulation occurs at the same or at a different site than a reference stimulus
- 24 right-handed male and 24 right-handed female subjects, ages 19-37 yr

Experimental Results

- The minimum detectable separation between two points (two-point threshold) and point localization vary with the site of stimulation.
- Variations by body site in the two-point threshold and point localization are highly correlated (rank-order correlation = 0.92). The difference between the two-point threshold and the point localization threshold is relatively constant across all body sites. The mean ratio of the two-point threshold to localization threshold is 3.5:1 (standard error of the mean = 10%).
- Neither measure is correlated with sensitivity to pressure (CRef. 3.106).
- Results for males and females are highly correlated for both the two-point threshold (rank-order correla-

tion = 0.96) and tactile localization (rank-order correlation = 0.89).

- Sensitivity is generally highest at the fingers, face, and toes (for males and females for both measures).
- The apparent paradox that the error of localization at a site is less than the distance required to perceive two points is explained by Békésy (Ref. 2) as reflecting the action of neural funneling produced by **lateral inhibition**.

Variability

Analysis of variance used to evaluate results for both measures.

Repeatability/Comparison with Other Studies

Similar results were reported in Ref. 3 and discussed in Refs. 1 and 2.

Constraints

- Two-point thresholds can be greatly reduced with practice.
- Other methods of evaluating tactile spatial resolution have indicated much smaller threshold values.

Key References

1. Boring, E. G. (1942). *Sensation and perception in the history of experimental psychology*. New York: Appleton-Century.

2. Békésy, G. von (1967). *Sensory inhibition*. Princeton, NJ: Princeton University Press.

3. Ruch, T. C., Patton, H. D., Woodbury, J. W., & Towe, A. L. (Eds.). (1965). *Neurophysiology*. Philadelphia: W. B. Saunders.

*4. Weinstein, S. (1968). Intensive and extensive aspects of tactile sensitivity as a function of body part, sex and laterality. In D. R. Kenshalo (Ed.), *The skin senses* (pp. 195-222). Springfield, IL: Thomas.

Cross References

3.105 Apparatus for static and vibratory (mechanical) stimulation of the skin;

3.106 Pressure and vibration sensitivity;

3.119 Tactile, auditory, and visual shifts in perceived target location due to stimulus interactions;

Handbook of perception and human performance, Ch. 12, Sect. 4.3

3.116 Vibrotactile Stimulation: Effect of Adaptation on Detectability and Perceived Magnitude

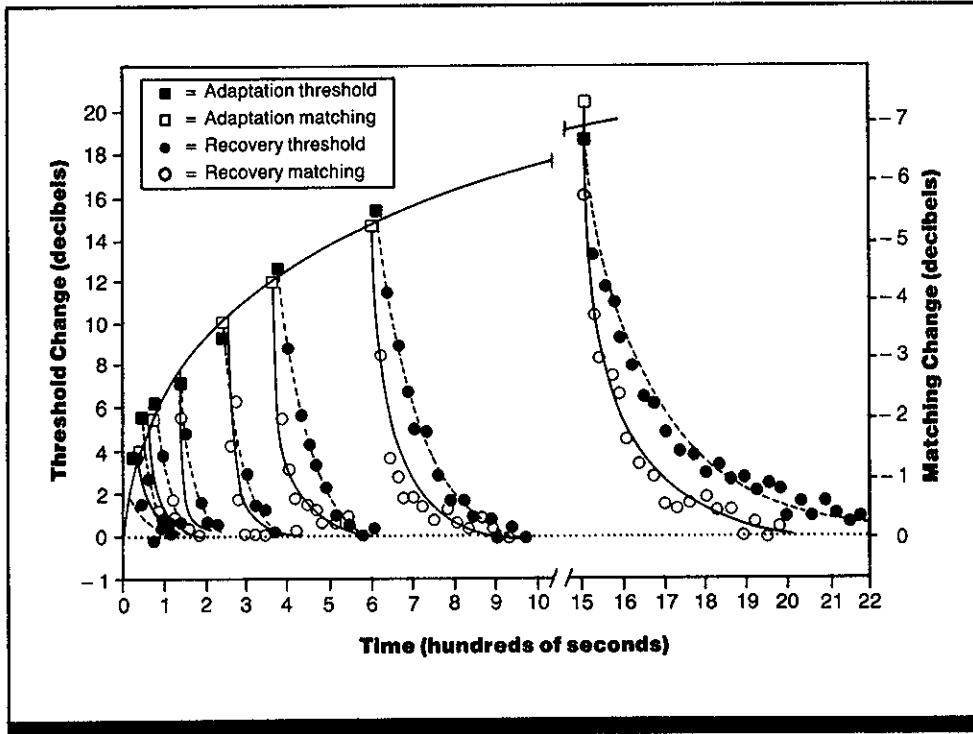

Figure 1. Decline in tactile sensitivity after adaptation to a 60-Hz vibrotactile stimulus, expressed as the difference in stimulus intensity required to reach detection threshold (left vertical axis, filled symbols) or match a standard stimulus in apparent magnitude (right vertical axis, unfilled symbols) before and after exposure to the adapting stimulus (in decibels re threshold intensity before adaptation). Adaptation measurements were taken immediately after the adapting stimulus was turned off; recovery measurements, at various intervals after offset of the adapting stimulus. (From Ref. 2)

Key Terms

Adaptation; tactile detection; tactile sensation magnitude; touch; vibration sensitivity; vibrotactile stimulation

General Description

When sensitivity to a vibrotactile stimulus is measured by determining either minimal perceptible intensity (absolute threshold) or perceived magnitude (matching), sensitivity decreases as length of prior stimulus exposure (adaptation period) increases. The absolute threshold for a stimulus is

more strongly affected by the duration of previous adaptation than is its perceived magnitude. Relative changes in threshold are almost three times greater than changes in perceived magnitude, and recovery to baseline levels of sensitivity (following adaptation period) is slower.

Applications

Control systems with high levels of continuous vibration where signals must be superimposed at similar frequencies.

Methods

Test Conditions

- 60-Hz vibration presented continuously by 6-mm diameter skin contactor exerting a static force of 20 gm and positioned on the left or right index finger pads
- During adaptation, adapting stimulus maintained at a constant intensity of 200 μm displacement (mean of 34-dB sensation level for

subjects) for eight durations from 10-1500 sec

- For threshold measurements, test stimulus presented through same contactor as adaptation stimulus
- For magnitude-matching measurements, standard stimulus was a 1-sec presentation of adapting stimulus; comparison stimulus was delivered to index finger of opposite hand via duplicate contactor system

Experimental Procedure

- Modified method of limits (stimulus intensity changed continuously rather than in steps; only ascending series used)
- Independent variable: duration of adaptation period
- Dependent variables: change in minimal stimulus intensity required for detection (absolute threshold), change in stimulus intensity required to match perceived magnitude of standard

- Subjects task: indicate point at which stimulus is just detectable (absolute threshold) or point at which comparison stimulus is equal in perceived magnitude to standard stimulus
- Seven threshold measurements per adaptation duration; 12 magnitude matches per adaptation duration
- 3 well-practiced subjects

Experimental Results

- Detectability and perceived magnitude of a vibrotactile stimulus decrease with increasing duration of a prior adapting stimulus.
- The change in stimulus detectability (absolute threshold) after adaptation is 2.8 times greater than the change in apparent stimulus magnitude (matching).
- Recovery to baseline sensitivity (following termination of adaptation) is faster for matching than for absolute threshold measurements. Recovery requires $\sim 50\%$ of the duration of the adaptation.

- For both methods of measurement, adaptation is still increasing (i.e., sensitivity is decreasing) even after 1500 sec (25 min) of exposure to the adapting stimulus.

Variability

No information on variability was given.

Repeatability/Comparison with Other Studies

Similar results for other stimulus frequencies are reported in Ref. 3. Using a different psychophysical method, Ref. 1 found perceived magnitude of vibratory stimulus to increase as a power function of vibration amplitude with time following offset of adapting stimulus.

Constraints

- Subjects' magnitude matches after adaptation are expressed in terms of ratios of adapted to unadapted matches to correct for time-order errors resulting from successive presentation of standard and comparison stimuli.
- Some recovery occurred during the delay between the offset of the adapting stimulus and the time the first measurement could be made. Because of this, the adaptation

function for threshold is estimated to be ~ 1.5 dB too low and the adaptation function for matching, ~ 1.0 dB too low.

- Vibrotactile sensitivity and apparent magnitude are affected by many factors, including the size of the stimulated area, the frequency of vibration, stimulus duration, use of a stimulator with a static surround, body site of stimulation, and skin temperature (CRefs. 3.106, 3.107, 3.108, 3.111, 3.112, 3.113, 3.114). These factors should be considered in applying these results under different conditions.

Key References

1. Gescheider, G. A., & Wright, J. H. (1968). Effects of sensory adaptation on the form of the psychophysical magnitude for cutaneous vibration. *Journal of Experimental Psychology*, 77, 308-313.

*2. Hahn, J. F. (1966). Vibrotactile adaptation and recovery measured by two methods. *Journal of Experimental Psychology*, 71, 655-658.

3. Hahn, J. F. (1968). Low frequency vibrotactile adaptation. *Journal of Experimental Psychology*, 78, 655-659.

Cross References

3.105 Apparatus for static and vibratory (mechanical) stimulation of the skin;

3.106 Pressure and vibration sensitivity;

3.107 Vibrotactile stimulation: detectability of tactile pulses of varying duration;

3.108 Vibrotactile stimulation: effect of frequency and type of spatial surround;

3.111 Vibrotactile stimulation: perceived magnitude;

3.112 Vibrotactile stimulation: perceived magnitude as a function of number of active vibrators;

3.113 Vibrotactile stimulation: summation of perceived magnitude;

3.114 Vibrotactile stimulation: enhancement of perceived magnitude

3.117 Vibrotactile Stimulation: Detectability in the Presence of Masking

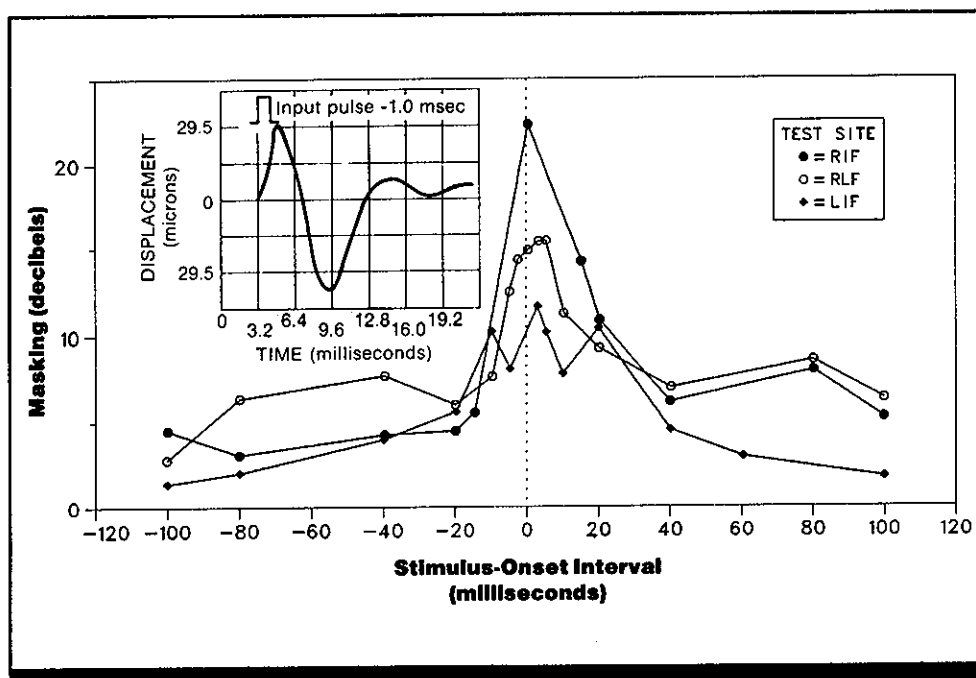

Figure 1. Masking of one vibrotactile stimulus (target) by a second vibrotactile stimulus (mask) as a function of the interval between the onsets of the stimuli. Masking is measured as the threshold intensity of the target when the mask is present, in decibels re threshold intensity when the mask is absent (i.e., threshold elevation for the masked versus the unmasked target). Inset shows waveform of input pulse at the surface of the skin. Negative values for interstimulus-onset interval indicate that the mask was presented after the target; positive values indicate that the mask preceded the target. The mask was always presented to the right index finger. The target was presented to the right index finger, right little finger, or left index finger. (From Ref. 3)

Key Terms

Pressure sensitivity; stimulus interaction; tactile masking; touch; vibration sensitivity; vibrotactile stimulation.

General Description

The intensity required to detect a vibrotactile stimulus increases with a decrease in the time interval between the onset of this target stimulus and the onset of a second, masking stimulus (the interstimulus-onset interval). Al-

though this masking effect is reduced as the distance between stimulation sites is increased, it is never eliminated, and persists even when target and mask are presented to different hands.

Applications

Designs incorporating multiple tactile signals which occur close together in time and/or space.

Methods**Test Conditions**

- Pairs of 1.0-msec pulses presented through 6.5-mm diameter skin contactors; (waveform of pulse at skin surface shown in inset to Fig. 1)
- Pulse pairs presented at rate of one pair per 1.5 sec with

interstimulus-onset interval from 0-100 msec; mask could precede or follow presentation of target

- Target stimulus presented to right index finger (RIF), right little finger (RLF), or left index finger (LIF)

- Masking stimulus presented to right index finger (RIF) at intensity of 20 dB above threshold

Experimental Procedure

- Method of adjustment
- Independent variables: interstimulus-onset interval, location of target stimulus

- Dependent variable: amount of masking, defined as threshold elevation in decibels
- Subject's task: adjust intensity of target stimulus until target could not be perceived
- Two determinations per condition
- 3 trained subjects

Experimental Results

- The intensity required to detect a vibrotactile target stimulus increases as the time interval between the target and a second vibrotactile masking stimulus (preceding or following presentation of the target) decreases from 100 to 0 msec.
- This masking effect increases as the physical distance between target and masking stimulus decreases.

Variability

Standard errors of the mean range between 1 and 2 dB across all conditions.

Repeatability/Comparison with Other Studies

Results are similar to those reported in Ref. 3 for electrocutaneous stimuli and in Refs. 1 and 2 for auditory stimuli (CRef. 2.312)

Constraints

- Results are likely to vary with different body loci (CRef. 3.106).

Key References

1. Elliott, L. L. (1962). Backward masking: Monotic and dichotic conditions. *Journal of the Acoustical Society of America*, 34, 1108-1115.

2. Raab, D. H. (1961). Forward and backward masking between acoustic clicks. *Journal of the Acoustical Society of America*, 33, 137-139.

*3. Sherrick, C. E. (1964). Effect of double simultaneous stimulation of the skin. *American Journal of Psychology*, 77, 42-53.

Cross References

- 2.312 Auditory sensitivity in noise: nonsimultaneous masking;
- 3.105 Apparatus for static and vibratory (mechanical) stimulation of the skin;
- 3.106 Pressure and vibration sensitivity

3.118 Tactile and Auditory Localization: Effect of Interstimulus-Onset Interval

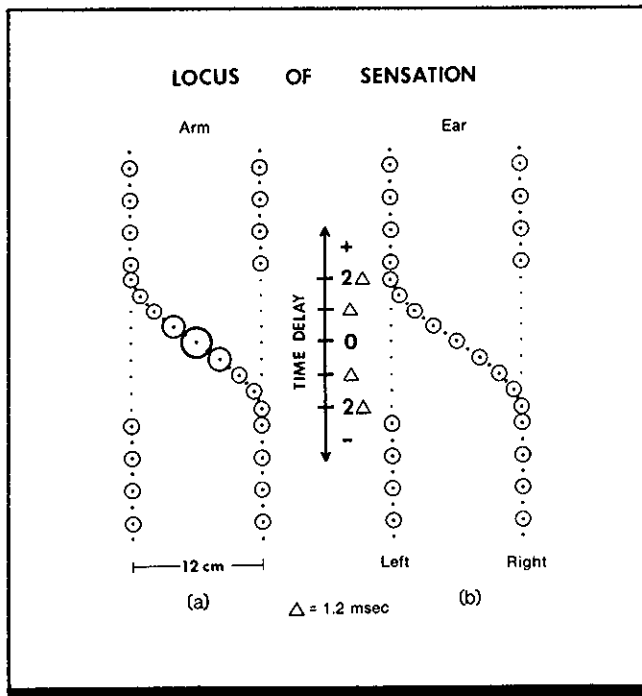

Figure 1. Perceived location of two tactile stimuli to the arm and two dichotically presented auditory stimuli as a function of interstimulus time delay. The vertical axis shows the interval between the onset of the first and second stimulus of each pair for each sensory modality; positive values indicate that the left stimulus occurred first. For tactile stimuli, size of the circle marking perceived locus indicates the relative apparent size of the tactile sensation. (From Ref. 2)

Key Terms

Auditory localization; lateralization; tactile localization; touch

General Description

The apparent position of two tactile pulses or two auditory clicks changes as the interval between the onsets of the two stimuli (i.e., the interstimulus-onset interval) approaches zero. At stimulus-onset intervals >2 msec, the stimuli are perceived as occurring at separate locations. At shorter interstimulus-onset intervals, the two stimuli are perceived as

a single phantom stimulus positioned between the stimulated locations. For tactile stimulation, the phantom stimulus decreases in apparent intensity and increases in apparent size as it moves toward the center position; for auditory stimulation, the apparent intensity and size of the phantom stimulus stay constant.

Methods

Test Conditions

- Pairs of tactile pulses of equal perceived intensity delivered by two skin contactors placed 12 cm apart on the inner arm
- Pairs of auditory clicks of equal loudness presented dichotically to the two ears

Experimental Procedure

- Interstimulus-onset intervals varied in ascending and descending series, but changes are not described as continuous or discrete
- Independent variables: interstimulus-onset interval, sensory modality that is stimulated

- Dependent variables: apparent location of stimulus source, apparent intensity of stimulus
- Subject's task: indicate apparent location and intensity of sensation, usually by pointing
- No information given on number or characteristics of subjects

Experimental Results

- For both tactile and auditory pulse pairs, presented sequentially, as the interstimulus-onset interval decreases to ~2 msec, the apparent intensity of the first stimulus increases and that of the second stimulus decreases until a single sensation occurs at the location of the first stimulus.
- As the time delay decreases from 2 msec to zero, the single tactile sensation decreases in intensity and increases in size as it moves to a perceived position between the two points of stimulation. The single auditory sensation remains constant in size and intensity as it moves to a central position.
- As the onsets of the stimuli are reversed (i.e., the second stimulus becomes the first and vice versa) and the interstimulus-onset interval increases, the effects reverse and the single phantom stimulus separates into two stimuli.

- The same movement phenomena occur when one tactile stimulator has a ten times larger surface than the other, but the area of sensation is greater for the larger stimulus and even greater when the sensation is in the middle.

Variability

Some variability among subjects is reported, but no estimates are provided. The two stimuli never became one sensation for some subjects.

Repeatability/Comparison with Other Studies

Similar patterns of location change occur on the finger and other parts of the skin. Similar results also occur when the skin is anesthetized by local cooling with ethyl chloride spray and when electrocutaneous stimulation is used. Comparable illusory tactile sensations have been reported in Ref. 1. Reference 3 found that a time delay of 2-4 msec was needed to produce full phantom localization for tactile stimuli.

Constraints

- The two stimuli must have the same sensation magnitude to yield a smooth movement.
- Differences in the apparent magnitude of the two stimuli can lead to shifts in localization comparable to those produced by interstimulus time delays. Perceived intensity differences and time delays interact and can be made to

compensate for one another in determining apparent location of stimulus pairs (Ref. 1, CRef. 2.809).

- The apparent spread in the area of sensation for tactile stimuli localized as a single, central phantom diminishes for smaller interstimulus distances and for more densely innervated body parts (Ref. 1).

Key References

1. Alles, D. S. (1970). Information transmission by phantom sensation. *IEEE Transactions on Man-Machine Systems*, 11, 85-91.

*2. Békésy, G. von (1960). *Experiments in hearing*. New York: McGraw-Hill.

3. Gescheider, G. A. (1974). Temporal relations in cutaneous stimulation. In F. A. Geldard (Ed.), *Cutaneous communication systems and devices* (pp. 33-37). Austin, TX: Psychonomic Society.

Cross References

2.807 Lateralization of clicks with interaural time delay;

2.809 Trading between interaural intensity differences and interaural time differences in auditory lateralization;

3.105 Apparatus for static and vibratory (mechanical) stimulation of the skin;

3.119 Tactile, auditory, and visual shifts in perceived target location due to stimulus interactions;

3.120 Apparent movement of vibrotactile and electrocutaneous stimuli

3.119 Tactile, Auditory, and Visual Shifts in Perceived Target Location Due to Stimulus Interactions

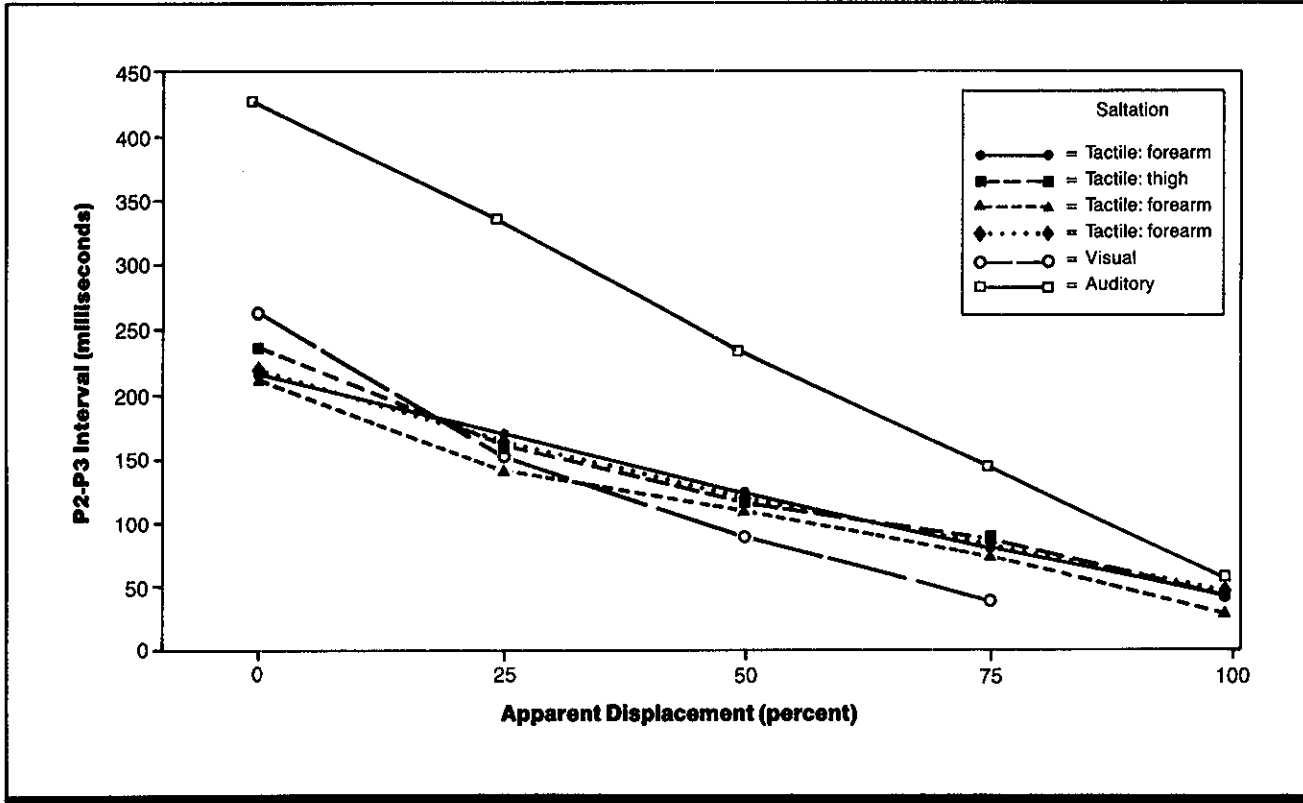

Figure 1. Relation between the interval separating the onset of one stimulus (P_2) from the onset of a second stimulus (P_3) at a different location, and the apparent spatial displacement of the first stimulus toward the second. Apparent displacement is expressed as the perceived distance between the two stimuli as a percentage of the actual distance between them. When apparent displacement is 0%, the first stimulus appears located at its true position; when displacement is 100%, it appears located at the same position as the second stimulus. (From *Handbook of perception and human performance*: tactile data are from several different studies described in Refs. 1 and 2; auditory data from a study described in Ref. 2; and visual data from a study reported in Ref. 1)

Key Terms

Auditory localization; sensory saltation; stimulus interaction; tactile localization; touch; visual localization

General Description

When a tactile, auditory, or visual stimulus is followed closely in time by another stimulus in the same sensory modality at a second site, the apparent location of the first stim-

ulus is shifted in the direction of the following stimulus. This perceived displacement, known as sensory saltation, increases as the interval between onset of the first and second stimuli decreases.

Applications

Displays incorporating signals presented close together in time at different spatial locations; interpretation of augmented cueing or simulation.

Methods

Test Conditions

- Tactile stimulus was 10-12 dB pulses above threshold, delivered via two vibratory skin contactors separated by 10-15 cm, and resting with a static force of 10 gm on either the anterior thigh or the forearm; some of the tactile studies used haversine pulses and others used unidirectional rectangular pulses
- Auditory stimuli were 0.1-msec rectangular pulses passed through a

2400-3200-Hz band-pass filter; stimuli were presented at 40 dB above threshold through two ear-phones 60 deg apart to the left of subject's midline and suspended 1.25 m from the subject in a room with sound attenuation

- Visual stimuli were 0.5-deg diameter strobe flashes separated vertically by 5 deg of visual angle and presented peripherally at 35 deg from the fixation point
- Typical trial sequence: a stimulus, P_1 , was presented as a location marker; the first test stimulus (P_2) was presented at the same site after an 800-msec delay; after another

delay (e.g., 20-500 msec), a second test stimulus (P_3) was presented at a second site; trial sequences were presented repeatedly (e.g., 10 trials per min)

- All stimuli in each sensory modality were of equal apparent intensity

Experimental Procedure

- Method of adjustment with fractionation procedure
- Independent variables: proportion of apparent P_1 - P_3 distance to be matched by subject; stimulus modality

- Dependent variable: interstimulus-onset interval between P_2 and P_3 at which P_2 appeared at a specific spatial location
- Subject's task: adjust time delay between P_2 and P_3 until P_2 appeared to be located at a specific fraction of the distance between P_1 and P_3 (e.g., at one-fourth, one-half, or three-fourths the P_1 - P_3 distance, or at the same location as either P_1 or P_3)
- Tactile data obtained over a series of years by a variety of investigators and subjects; auditory data obtained from 8 subjects; visual data obtained from 3 subjects

Experimental Results

- Perceived displacement of a prior stimulus (P_2) toward the location of another stimulus (P_3), presented after a brief delay, occurs in cutaneous perception, audition, and vision.
- For all stimuli, perceived distance between the two stimuli become more accurate with longer intervals between stimulus-onset times. The slope of the function is least for tactile stimuli.
- The presentation of multiple taps at the P_2 site yields the perception of a series of taps that begins at the P_2 site and ends at the P_3 site, as long as the total duration of the P_2 train + P_3 is approximately 250 msec or less.
- In cutaneous and auditory perception, the two stimuli are perceived at the same location when the interstimulus-onset

interval equals 20-50 msec. In visual perception, the perceived distance between the two stimuli is never less than 20% of the actual distance (i.e., the two stimuli never appear to be located at the same place regardless of interstimulus-onset interval).

Variability

Standard errors of the means range from 1.3 at the 0% distance setting to 34.5 msec at the 100% setting for tactile stimuli (across all studies) and from 8.5-45.5 msec for auditory stimuli.

Repeatability/Comparison with Other Studies

Many related studies showing similar results are cited in Ref. 2.

Constraints

- Increasing the distance between stimulation sites can eradicate the effect.
- Saltation cannot be induced across the midline for skin and eyes; a midline barrier for the ear has not been demonstrated.

Key References

*1. Geldard, F. A. (1975). *Sensory saltation: Metastability in the perceptual world*. Hillsdale, NJ: Erlbaum.

*2. Geldard, F. A. (1982). Saltation in somesthesia. *Psychological Bulletin*, 92, 136-175.

3. Geldard, F. A., & Sherrick, C. E. (1983). The cutaneous saltatory area and its presumed neural basis. *Perception & Psychophysics*, 33, 299-304.

4. Sherrick, C. E. (1982). Cutaneous communication. In W. E. Neff (Ed.), *Contributions to sensory physiology* (Vol. 6, pp. 1-42). New York: Academic Press.

Cross References

- 2.801 Sound localization;
3.105 Apparatus for static and vibratory (mechanical) stimulation of the skin;
3.118 Tactile and auditory localiza-

tion: effect of interstimulus-onset interval;

3.120 Apparent movement of vibrotactile and electrocutaneous stimuli;

Handbook of perception and human performance, Ch. 12, Sect. 4.4

3.120 Apparent Movement of Vibrotactile and Electrocutaneous Stimuli

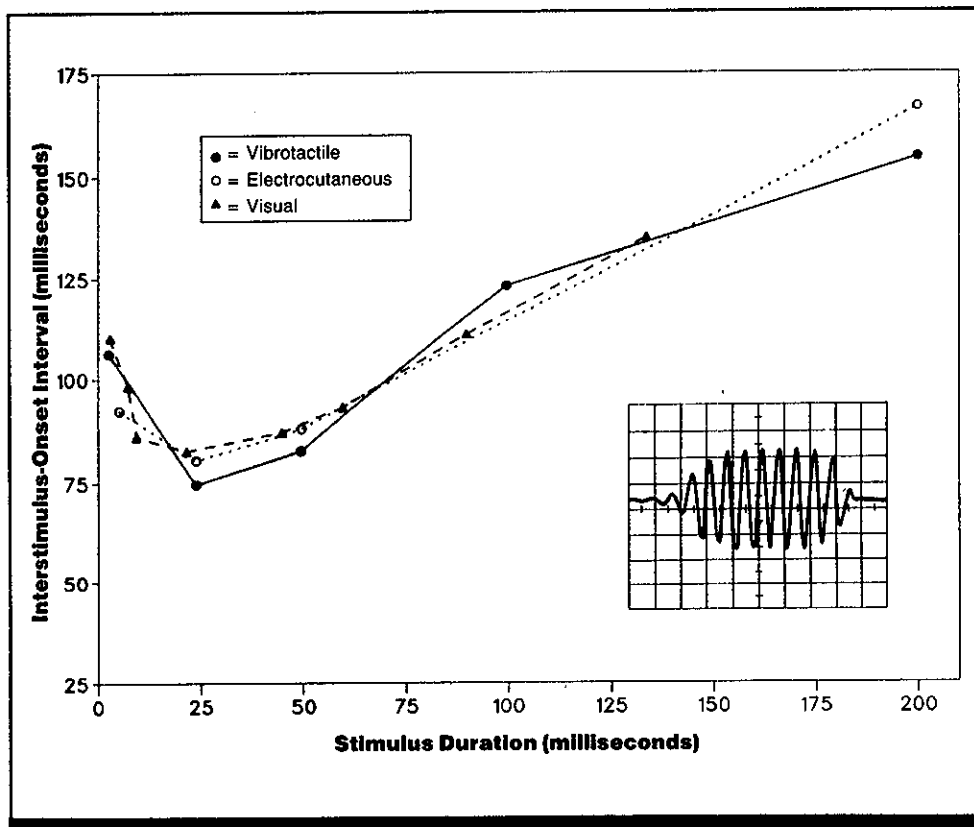

Figure 1. Interval between onsets of two stimuli at different spatial locations yielding optimal apparent movement as a function of stimulus duration for vibrotactile and electrocutaneous stimulation. The inset is an oscillographic tracing of a 50-msec burst of 150-Hz sinusoid used for one of the vibrotactile stimulus pairs. Data for visual stimuli (from Ref. 2) are shown for comparison. (From Ref. 4)

Key Terms

Apparent movement; electrocutaneous stimulation; motion perception; spatiotemporal interaction; touch; vibrotactile stimulation

General Description

Two vibrotactile or two electrocutaneous stimuli presented in rapid succession at different spatial locations will appear as a single moving source. The interstimulus-onset

interval yielding the greatest degree of apparent movement increases as stimulus duration increases for exposure time >25 msec. This relationship is similar to that observed for apparent movement between two visual stimuli.

Applications

Displays in which actual movement cannot be produced but can be simulated with only two generating loci.

Methods

Test Conditions

- Vibrotactile stimuli were 150-Hz bursts of sinusoids presented at an intensity of 15 dB (re threshold for 200-msec burst at distal locus) to 6-mm diameter skin contactors with a static force of ~100 gm
- Electrocutaneous stimuli were 1-kHz signals at 3-dB sensation

level transmitted by annular electrodes having a 0.5-cm² center and 6.8-cm² surround

- Stimuli presented to front thigh at various interstimulus distances (range not reported)
- Vibrotactile stimulus durations 25-400 msec with single transient tap presented for 3 msec; electrocutaneous stimulus durations 5-400 msec

Experimental Procedure

- Method of adjustment
- Independent variables: stimulus modality, stimulus duration, interstimulus distance
- Dependent variable: interstimulus-onset interval for best apparent movement, defined as longest uninterrupted feeling of stimulus moving between first and second stimulation sites

- Four trials per stimulus duration; one stimulus duration per session; sessions covering a period of 14 months
- Subject's task: adjust interstimulus-onset interval for best apparent motion
- 4 subjects with extensive practice

Experimental Results

- An illusion of movement between spatial locations occurs when two vibrotactile or electrocutaneous stimuli are presented at different spatial locations in rapid succession.
- The interstimulus-onset interval that produces the best apparent movement increases as stimulus duration increases for interstimulus-onset intervals >25 msec.
- Functions relating interstimulus-onset interval and stimulus duration are very similar for both vibrotactile and electrocutaneous stimuli, and closely parallel the results for visual apparent movement. (Visual data from Ref. 2 are shown in Fig. 1 for comparison.)
- The interstimulus-onset interval for best apparent movement is not affected by interstimulus distance when the stimulation sites are <30 cm apart.

Variability

Standard errors of the means range from 3-11 msec for vibrotactile stimulation. For 400-msec stimuli (not shown in the figure), the mean interstimulus-onset interval for best apparent movement was 246 msec (standard deviation = 86 msec) for vibrotactile stimulation and 223 msec (standard deviation = 97 msec) for electrocutaneous stimulation. No other information was given on variability for electrocutaneous stimulation.

Repeatability/Comparison with Other Studies

The tactile results have been replicated almost exactly (Ref. 1) using different methods and stimulation sites. Similar results with only one stimulus duration have been reported for audition (Ref. 2).

Constraints

- The quality of apparent movement is rapidly degraded when stimulation sites are >30 cm apart or are on opposite sides of a joint.

Key References

1. Kirman, J. H. (1974). Tactile apparent movement: The effects of interstimulus-onset interval and stimulus duration. *Perception & Psychophysics*, 15, 1-6.
2. Neuhaus, W. (1930). Experimentelle Untersuchung der Schein-

bewegung. *Archiv für die Gesamte Psychologie*, 75, 315-458.

3. Perrott, D. R. (1974). Auditory apparent motion. *Journal of Auditory Research*, 14, 163-169.

*4. Sherrick, C. E., & Rogers, R. (1966). Apparent haptic movement. *Perception & Psychophysics*, 1, 175-180.

Cross References

- 3.105 Apparatus for static and vibratory (mechanical) stimulation of the skin;

- 3.119 Tactile, auditory, and visual shifts in perceived target location due to stimulus interactions;
- 5.401 Types of visual apparent motion;

- 5.403 Temporal and spatial relationships in visual apparent motion; *Handbook of perception and human performance*, Ch. 12, Sect. 4.4

3.121 Sensitivity to Warmth: Effect of Stimulation Area and Body Site

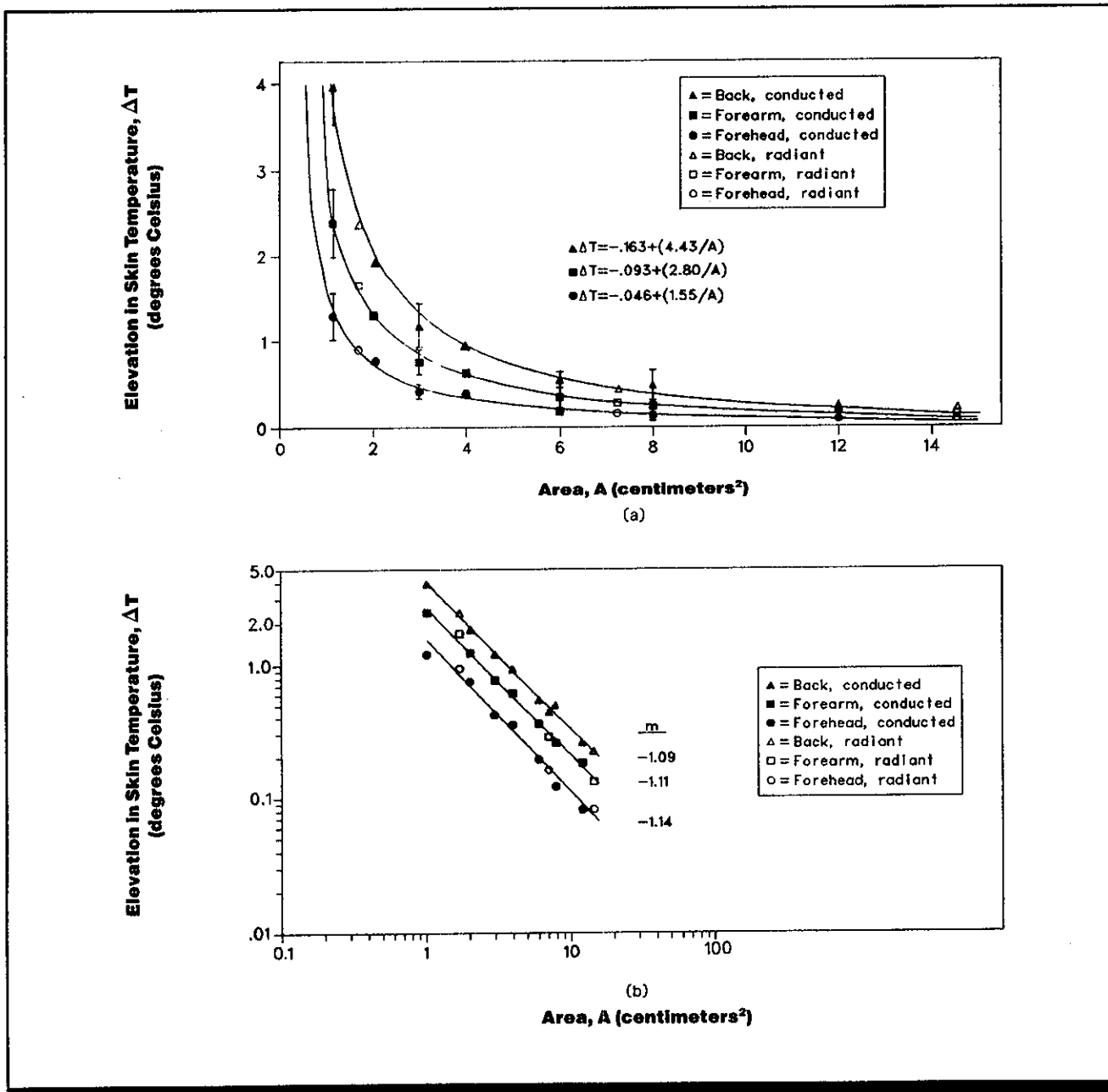

Figure 1. Elevation in skin temperature necessary to produce a sensation of warmth as a function of area of stimulation, for radiant and conducted heat. Data are plotted on (a) linear and (b) log-log coordinates. Thresholds are shown for conducted and radiant heat for stimulation sites on the back, forearm, and forehead. Hyperbolic functions as shown were fit to the data in (a). In (b), m is the slope of the fit functions and indicates the extent of spatial summation. (See text for details.) (From Ref. 3)

Key Terms

Heat; spatial summation; temperature sensitivity; thermal stimulation

General Description

Sensitivity to radiant or conducted heat increases (i.e., thresholds to warm stimuli decrease) as the area of stimulation increases. The forehead is most sensitive, followed by the forearm and then the back.

Methods

Test Conditions

- Radiant heat produced by hot-plate coil, presented through round apertures of 1-12 cm² placed 5 mm from the skin
- Conducted heat produced by stimulators with an area of 1.7-14.4 cm² resting on the skin with a force of 11 g/cm²

- Both radiant and conducted heat presented for 3-sec periods at 3-min intervals
- Intensity of radiant stimuli measured by an Eppley thermopile positioned at location of test site
- Intensity of conducted heat stimuli measured by a thermocouple placed between the skin and the stimulator surface
- Test sites were center of forehead, inner forearm 5 cm below elbow, and back 4 cm below shoulder blade and 4 cm to left of the spinal column

der blade and 4 cm to left of the spinal column

Experimental Procedure

- Method of limits
- Independent variables: conducted or radiant heat, size of stimulated area, test site
- Dependent variable: threshold for warmth, as measured by elevation of skin temperature (°C) necessary for subject to report a sensation of warmth

sary for subject to report a sensation of warmth

- Subject's task: report sensations of warmth or no warmth to thermal stimuli
- Skin blackened with India ink 30 min before the session started
- Eight measurements (four ascending and four descending series) per stimulus area per test site
- 1 male and 1 female subject with extensive practice

Experimental Results

- Sensitivity to radiant or conducted heat increases as the area of stimulation increases.
- When the data are plotted on linear coordinates (Fig. 1a), a rectangular hyperbolic function of the form $\Delta T = K + L/A$ shows a good fit to the data, where ΔT is the threshold for warmth in °C, K is the threshold in °C for very large areas (>2000 cm²), L is a site-dependent constant expressed in °C per cm², and A is the area of stimulation in cm². This method of plotting shows that warmth threshold reaches an asymptote as the area of stimulation grows in size.
- Figure 1b shows the same data plotted on log-log scale. When plotted in this way, the relation between warmth threshold and stimulation area is linear and can be described by the function $\Delta T = K + LA^m$, where ΔT , K , L , and A are defined previously and the exponent m indicates the extent to which **spatial summation** is complete. Exponents for all

body sites tested are approximately equal to -1.0 . This indicates almost perfect spatial summation, i.e., the change in temperature required to reach threshold is halved when the area of exposure is doubled.

- The forehead is more sensitive to heat than is the forearm, which in turn is more sensitive than the back.
- Sensitivity is not affected by the method used to increase skin temperature (radiant versus conducted heat).

Variability

Standard error bars are based on means of eight measurements per condition.

Repeatability/Comparison with Other Studies

Similar effects for cold are reported in Ref. 1. Partial summation of temperature thresholds between two separate stimulation sites is reported in Ref. 2.

Constraints

- Sensitivity to warmth and coldness is influenced by the temperature to which the skin is adapted (CRef. 3.123), and the rate of change in stimulus temperature (CRef. 3.122).

Key References

1. Hardy, J. D., & Opper, T. W. (1938). Studies in temperature sensation. IV. The stimulation of cold sensation by radiation. *Journal of Clinical Investigation*, 17, 771-778.

2. Kenshalo, D. R. (1972). The cutaneous senses. In J. W. Kling & L. A. Riggs (Eds.), *Woodworth & Schlosberg's experimental psychology* (3rd ed.) (pp. 117-168). New York: Holt, Rinehart & Winston.

*3. Kenshalo, D. R., Decker, T., & Hamilton, A. (1967). Spatial summation on the forehead, forearm, and back produced by radiant and conducted heat. *Journal of Comparative and Physiological Psychology*, 63, 510-515.

Cross References

3.122 Detectability of warmth and cold: effect of rate of change in temperature;

3.123 sensitivity to warmth and cold: effect of adaptation temperature;

Handbook of perception and human performance, Ch. 12, Sect. 5.3

3.122 Detectability of Warmth and Cold: Effect of Rate of Change in Temperature

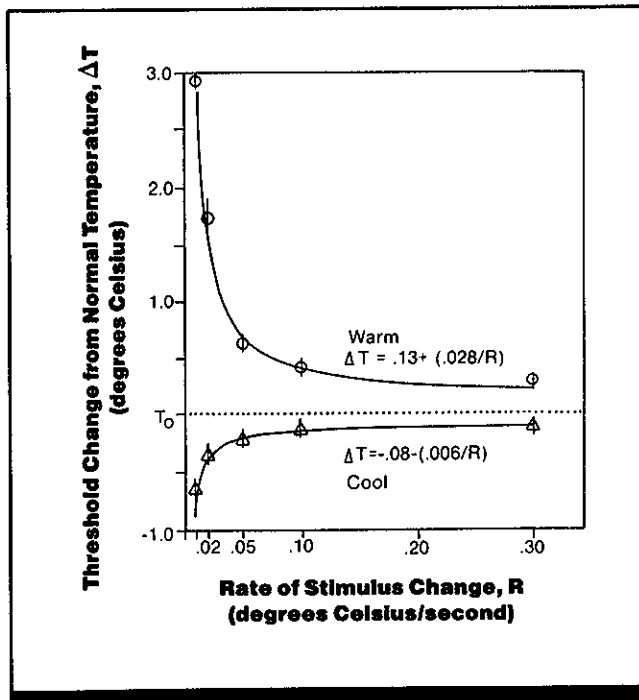

Figure 1. Change from normal skin temperature necessary to produce the sensation of warmth or coldness, as a function of the rate of temperature change. (Normal skin temperature, T_0 , is $\sim 31.5^\circ\text{C}$ for the subjects of this study.) Smooth curves represent hyperbolic functions fit separately to the thresholds for warmth and coldness as shown (see text for details). (From Ref. 1)

Key Terms

Cold; heat temperature sensitivity; thermal stimulation

General Description

The threshold for detecting warmth or cold (in relation to normal skin temperature) is constant for stimuli changing in temperature at rates of $0.1^\circ\text{C}/\text{sec}$ and above, but a larger

temperature change is necessary (i.e., sensitivity decreases rapidly) when slower rates are used. The effect is greater for detecting warming stimuli than for detecting cooling stimuli.

Methods

Test Conditions

- Thermal stimulator with surface area of 14.44 cm^2 rested on the shaved skin of the forearm with a pressure of $10.5\text{ gm}/\text{cm}^2$
- Stimulator provided temperature changes at rates between 0.01 and $0.3^\circ\text{C}/\text{sec}$

- Stimulator maintained at target temperature for 10 sec following temperature change at prescribed rate for ascending and descending series
- Stimulator maintained at normal skin temperature for 55 sec between test periods

Experimental Procedure

- Method of limits
- Independent variable: rate of temperature change
- Dependent variable: thermal threshold, defined as mean change in temperature ($^\circ\text{C}$) from normal skin temperature for a stimulus to be perceived as warm or cold
- Subject's task: indicate percep-

- tion of warmth, cold, or no change in stimulus temperature
- Hair shaved at experimental site at least 10 hr before session and subjects did not eat or smoke for 1 hr before session
- 18 measurements per rate of change for each subject
- 3 male subjects, extensive practice

Experimental Results

- The amount by which the temperature of a thermal stimulus must be raised or lowered to produce a sensation of warmth or cold is relatively constant when the temperature of the stimulus changes at rates above 0.1°C/sec. For rates of change below 0.1°C, however, increasingly larger temperature changes are necessary, the slower the rate of change in temperature.
- This decrease in thermal sensitivity with slow rates of temperature change is greater for warming stimuli than for cooling stimuli.

- Data for both warmth and cold thresholds can be fit by a rectangular hyperbolic function of the form $\Delta T = K + L/R$, where ΔT is the threshold temperature change (in °C), K is the asymptotic threshold level at very high rates of change (in °C), L is a range-specific constant (in °C/sec), and R is the rate of change in temperature (in °C/sec).

Variability

Standard error bars are based on 54 measurements per condition.

Constraints

- Sensitivity to thermal stimuli varies with test site and size of area stimulated, (CRef. 3.121) as well as with adapting temperature (CRef. 3.123).

Key References

*1. Kenshalo, D. R., Holmes, C. E., & Wood, P. B. (1968). Warm and cool thresholds as a function of rate of stimulus temperature change. *Perception & Psychophysics*, 3, 81-84.

Cross References

3.121 Sensitivity to warmth: effect of stimulation area and body site;

3.123 Sensitivity to warmth and cold: effect of adaptation temperature;

Handbook of perception and human performance, Ch. 12, Sect. 5.3

3.123 Sensitivity to Warmth and Cold: Effect of Adaptation Temperature

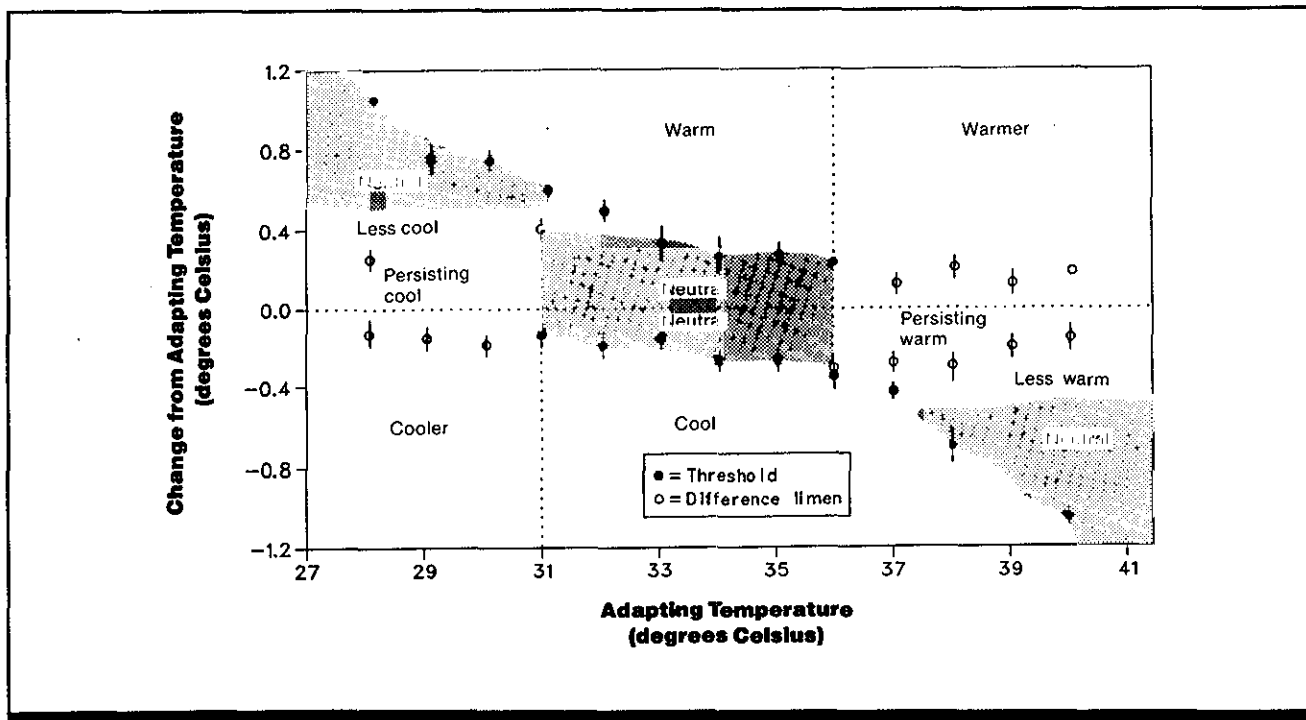

Figure 1. Absolute changes in thresholds for warmth and coolness, as a function of temperature to which the skin is adapted. Absolute thresholds for warmth and coolness are shown by the filled symbols. Open symbols show thresholds for a change in temperature (difference thresholds). Shaded areas represent zones of thermally neutral sensation. (From Ref. 1)

Key Terms

Cold; heat; temperature discrimination; temperature sensitivity; thermal adaptation

General Description

Sensitivity to a change in temperature varies with the temperature to which the skin is adapted. This is true for both absolute threshold (a perceived change from thermally neu-

tral to warm or cold) and difference threshold (a perceived change in intensity of warmth or coolness). The temperature range for complete adaptation (no residual sensation of warmth or coolness after continued exposure) is ~31-36°C.

Methods

Test Conditions

- Thermal stimulator with a contact area of 14.4 cm² rested on the shaved skin of back forearm 3 cm below the elbow with a force of 11.5 gm/cm²

- Stimulator maintained at adapting temperature of 28-40°C for 45 min prior to testing
- Stimulator temperature changed during testing at rate of 0.3°C/sec

Experimental Procedure

- Method of limits
- Independent variable: adapting temperature

- Dependent variables: absolute threshold, defined as the minimum change from the adapting temperature necessary for a stimulus to be perceived as changing from neutral to warm or cold; difference threshold, defined as the minimum perceptible change in temperature

- Subject's task: report when a change is perceived in stimulus temperature, identify the sensation as warm or cool
- Six measurements per condition
- 7 male subjects with extensive practice

Experimental Results

- Sensitivity to a change in temperature varies with the temperature to which the skin has been adapted (physiological zero).
- Adapting temperatures between 31-36°C produce thermally neutral sensations (no residual feeling of warmth or coolness) after continued exposure. For adapting temperatures in this range, the absolute threshold (detectability of a change from neutral to warm or cold) and difference threshold (detectability of a change in intensity of warmth or coolness) coincide.
- Even after prolonged exposure, adapting temperatures greater than ~36°C are perceived as warm and adapting temperatures less than ~31°C are perceived as cool (i.e., complete adaptation never occurs).

- For adapting temperatures in the zone of persisting thermal sensation (>36°C and <31°C), temperature changes in the opposite direction to the residual sensation pass through a thermally neutral zone before changing sign. For example, at a high adapting temperature, a warm sensation persists indefinitely. When a downward temperature change is introduced, a reduction in the persisting warm sensation is first felt. As the temperature is decreased further, the subject experiences a period of thermal neutrality, followed by a change to a cool sensation.

Variability

Standard error bars for representative points shown in the figure are based on the means of six measurements per condition.

Repeatability/Comparison with Other Studies

Similar results for warmth and coolness thresholds are reported in Ref. 3.

Constraints

- Sensitivity to warmth and coolness is influenced by the body site stimulated and the size of the stimulated area (CRef. 3.121), as well as the rate of change in stimulus temperature (CRef. 3.122).

- There are large individual differences in the temperature range for complete adaptation, with the range boundaries varying from 36-40°C for warmth and 28-31°C for coolness.

Key References

- *1. Kenshalo, D. R. (1970). Psychophysical studies of temperature sensitivity. In W. D. Neff (Ed.), *Contributions to sensory physiology*. New York: Academic Press.
2. Kenshalo, D. R. (1972). The cutaneous senses. In J. W. Kling & L. A. Riggs (Eds.), *Woodworth & Schlosberg's experimental psychology* (pp. 117-168). New York: Holt, Rinehart & Winston.
3. Lele, P. P. (1954). Relationship between cutaneous thermal thresholds, skin temperature and cross-sectional area of stimulus. *Journal of Physiology* (London), 126, 191-205.

Cross References

- 3.121 Sensitivity to warmth: effect of stimulation area and body site;
- 3.122 Detectability of warmth and cold: effect of rate of change in temperature;
- Handbook of perception and human performance*, Ch. 12, Sect. 5.3

3.124 Perceived Coolness and Warmth: Effect of Intensity and Duration of Stimulation

Key Terms

Cold; heat; temperature sensitivity; thermal adaptation; thermal sensory magnitude

General Description

Perceived coolness increases as exposure time to a thermal stimulus increases, but perceived warmth is almost invariant for exposure durations from 2-12 sec. Perceived magnitude of warmth and cold varies with stimulus intensity (thermal irradiance), but the functions relating perceived magnitude to stimulus duration are parallel for all intensities, indicating similar rates of sensory adaptation across intensity levels.

Applications

Designs in which the durations of thermal stimuli may change and where constant sensation magnitude is important.

Methods

Test Conditions

- Front surface of body irradiated by bank of heat lamps positioned 1.5-m above bed in which the subject lay in a supine position
- Baseline skin temperatures (temperature of subjective thermal neutrality) determined prior to testing
- Stimuli presented in random order after skin temperature returned to baseline at the end of each trial
- For judgments of warmth (Ref. 1), irradiance increased from baseline skin temperature by 14-90.6 mW/cm² for exposure times of 2-12 sec; room temperature maintained at 20°C with relative humidity of 30%
- For judgments of coolness (Ref. 2), irradiance decreased from baseline skin temperatures by 9.8-29.8 mW/cm² for exposure times of 3.9-30.9 sec; room temperature maintained at 3-4°C,

relative humidity <30%, and subject irradiated to thermal neutrality during non-test periods

Experimental Procedure

- Method of magnitude estimation
- Independent variables: duration of stimulus presentation, change in irradiance from baseline skin temperature
- Dependent variable: intensity magnitude estimates (in assigned numbers)
- Subject's task: assign numbers in proportion to the apparent intensities of warmth and cold
- For cold judgments, temperature changes are averages measured across 30 different body sites and corrected for skin reflection; for judgments of warmth, temperature was measured at the center of subject's chest
- 14 subjects for judgment of cold; 16 subjects for judgments of warmth

Experimental Results

- The apparent intensity of a cool stimulus increases as a negatively accelerated function of length of exposure. Although the rate of increase slows at longer exposure times, magnitude judgments are still growing, indicating that adaptation is not complete even after 30 sec of stimulation.
- The apparent intensity of a warm stimulus increases only slightly with increasing exposure time. Adaptation is close to complete within the first 2 sec of stimulation.

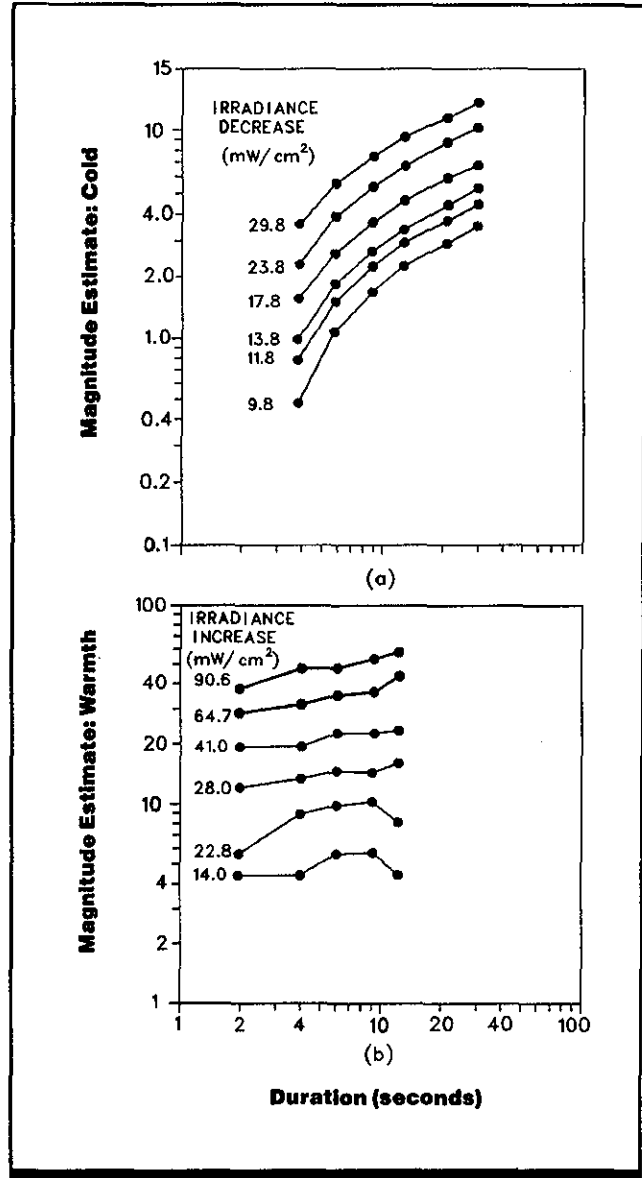

Figure 1. Subjective magnitude of (a) cold or (b) warmth as a function of stimulus duration, for various levels of stimulus intensity (irradiance increase or decrease from baseline skin temperature). (From Ref. 2)

Variability

Baseline skin temperatures vary ~8°C across subjects.

Repeatability/Comparison with Other Studies

The results for a small stimulus applied to the forearm or the hand immersed in water are reported in Ref. 3.

Constraints

- Different methods of presentation may produce different relations between apparent and actual thermal intensities.
- After 12-15 sec, sweating and vasomotor action may affect the time-course of sensation for warmth.

- Sensitivity to warmth and cold is influenced by the body site stimulated and the size of the stimulated area (CRef. 3.121), the temperature to which the skin is adapted (CRef. 3.123), and the rate of change in stimulus temperature (CRef. 3.122).

Key References

*1. Marks, L. E., & Stevens, J. C. (1968). Perceived warmth and skin temperature as functions of the duration and level of thermal irradiation. *Perception & Psychophysics*, 4, 220-228.

*2. Marks, L. E., & Stevens, J. C. (1972). Perceived cold and skin temperature as functions of stimulation level and duration. *American Journal of Psychology*, 85, 407-419.

3. Stevens, J. C., & Stevens, S. S. (1960). Warmth and cold: Dynamics of sensory intensity. *Journal of Experimental Psychology*, 60, 183-192.

Cross References

3.121 Sensitivity to warmth: effect of stimulation area and body site;

3.122 Detectability of warmth and cold: effect of rate of change in temperature;

3.123 Sensitivity to warmth and cold: effect of adaptation temperature;

Handbook of perception and human performance, Ch. 12, Sect. 5.3

3.125 Electrocutaneous Stimulation: Effect of Exposure Duration on Sensitivity

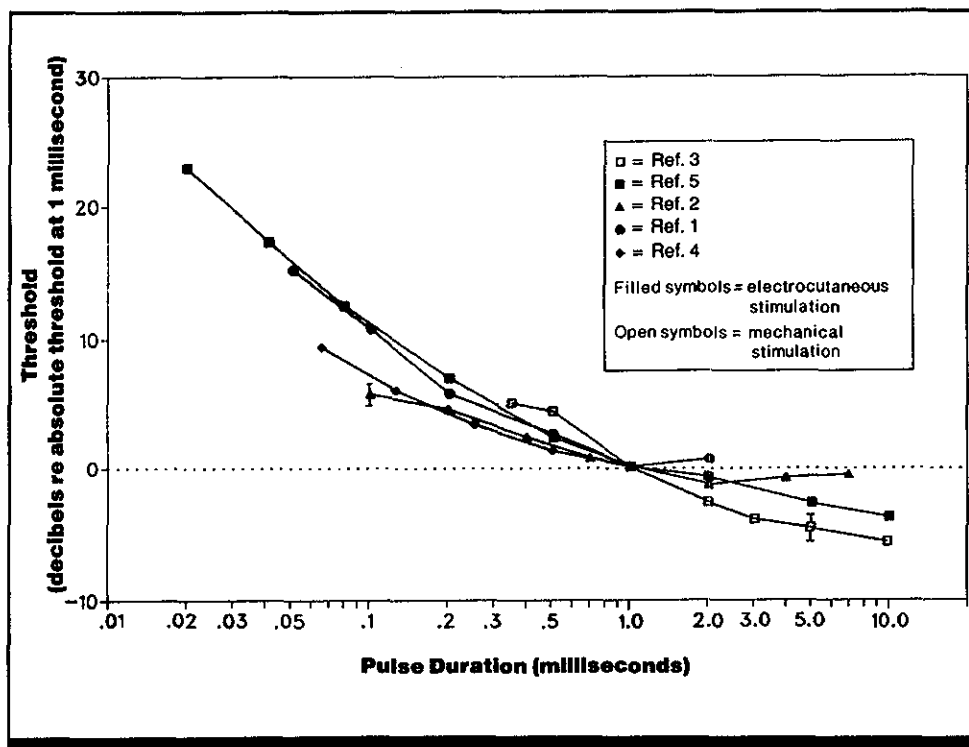

Figure 1. Threshold for electrical and mechanical stimulation as a function of pulse duration. The data for each study were normalized to the threshold for a 1-msec pulse. (From *Handbook of perception and human performance*)

Key Terms

Electrocutaneous stimulation; pressure sensitivity; tactile detection; temporal summation

General Description

Detectability of an electrocutaneous stimulus (electric current applied to the skin) increases (threshold intensity decreases) as the duration of the stimulus increases. The pattern of results agrees closely with that for mechanical stimulation of the skin.

Methods

Test Conditions

- Electrocutaneous stimuli were single, constant-current, square-wave pulses presented through electrodes to the right palm and index finger pad (Ref. 2), palm side of forearm (Ref. 5), forehead and

abdomen (Ref. 4), or middle finger with ring electrodes (Ref. 1)

- Mechanical stimuli (Ref. 3) consisted of single pulses delivered to the fingertips through a 0.64-mm (0.025-in.) diameter contactor (CRef. 3.107 for further detail).

- Stimuli presented for durations of 0.02-10.0 msec

Experimental Procedure

- Method of limits
- Independent variable: duration of stimulus pulse
- Dependent variable: threshold

intensity (in decibels re threshold at 1 msec)

- Subject's task: report occurrence or absence of sensation to stimulus pulses
- One subject for mechanical stimulus; 1-4 subjects for electrocutaneous stimuli

Experimental Results

- As stimulus duration increases, detection threshold for electrocutaneous stimuli decreases (stimulus detectability increases). The detectability of mechanical and electrocutaneous stimuli increases at comparable rates when data are normalized to threshold for 1-msec pulse duration.
- Absolute threshold reaches near-asymptotic levels at stimulus durations in the 1-10-msec range for several studies.
- In the studies reported here, threshold intensity for a 1-msec electrical pulse applied to the skin is 0.44 mA (Ref. 5), 0.76 mA (Ref. 2), and 1.76 mA (Ref. 1); threshold for a 1-msec mechanical pulse is 3.9 μm (Ref. 3).

Constraints

- The detectability functions may not be fully generalizable because some studies had very few (1-3) subjects.
- Detectability of electrocutaneous pulses will also vary with electrode size, stimulation site, stimulus waveform,

Variability

The ranges for two of the data points are shown in Fig. 1. Differences in electrode paste may lead to threshold variability (Ref. 4).

Repeatability/Comparison with Other Studies

The data for the studies can be compared when the data are normalized to the threshold for a common duration (e.g., 1 msec). However, differences among studies with other comparisons indicate different mechanisms may be responsible for electrocutaneous and mechanical pulse detection (Refs. 3, 5).

Key References

*1. Buchthal, F., & Rosenfalck, A. (1966). Evoked action potentials and conduction velocity in human sensory nerves. *Brain Research*, 3, 1-122.

*2. Hahn, J. F. (1958). Cutaneous vibratory thresholds for square-wave electrical pulses. *Science*, 127, 879-880.

*3. Hill, J. W. (1967). *The perception of multiple tactile stimuli* (Tech. Rep. No. 4823-1). Palo Alto, CA: Stanford University, Electronics Laboratory.

*4. Girvin, J. P., Marks, L. E., Antunes, J. L., Quest, D. O., O'Keefe, M. D., Ning, P., & Dobbelle, W. H. (1982). Electrocutaneous stimulation I. The effects of stimulus parameters on absolute threshold. *Perception & Psychophysics*, 32, 524-528.

*5. Rollman, G. B. (1974). Electrocutaneous stimulation. In F. Geldard (Ed.), *Cutaneous communication systems and devices* (pp. 38-51). Austin, TX: Psychonomic Society.

Cross References

3.107 Vibrotactile stimulation: detectability of tactile pulses of varying duration

3.126 Electrocutaneous stimulation: perceived magnitude;

Handbook of perception and human performance, Ch. 12, Sect. 8.2

pulse train length (e.g., with adaptation), and repetition rate (frequency).

- Some variables interact (e.g., pulse duration and train length; see Ref. 5).

3.126 Electrocutaneous Stimulation: Perceived Magnitude

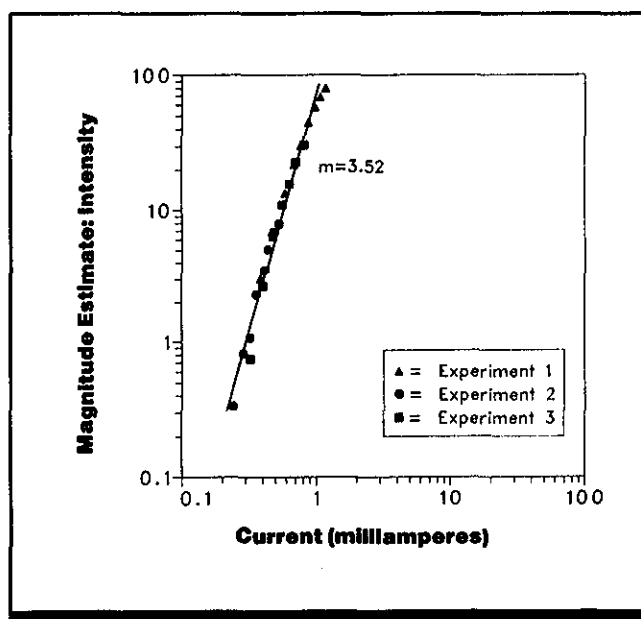

Figure 1. Growth of apparent magnitude of electrocutaneous stimuli with electric current. m is the slope of the power function fit to the data. Standard stimulus used for comparison in assessing magnitude was 1-sec 0.79-mA pulse in Exp. 1, 0.5-sec 0.37-mA pulse in Exp. 2, and 0.5-sec 0.5-mA pulse in Exp. 3. (From Ref. 3)

Key Terms

Electrocutaneous stimulation; tactile sensation magnitude

General Description

The apparent intensity of an electrocutaneous stimulus (electric current applied to the skin) increases with increasing current at a rate which is extremely rapid in comparison

to other classes of stimuli (e.g., vibrotactile or thermal stimulation). Individual differences can also be much greater for electrical stimulation than for other classes of stimuli.

Methods

Test Conditions

- All stimuli were 60-Hz electrical pulses delivered to two fingers (usually first and third) immersed up to the first joint in jars of saline solution

- Reference stimuli were: 1-sec electrical pulse of 0.79 mA (Exp. 1), 0.5-sec pulse of 0.37 mA (Exp. 2), or 0.5-sec pulse of 0.5 mA (Exp. 3); each experiment included a test series of 7-9 stimuli at different current levels centered on the reference value
- Reference stimuli were always

presented first and assigned the magnitude "10"

Experimental Procedure

- Method of magnitude estimation
- Independent variable: electric current level (in mA)
- Dependent variable: magnitude estimates of stimulus intensity (in assigned numbers)

Subject's task: assign numbers to the apparent intensities of electrical stimuli in proportion to a reference stimulus labeled "10"

- Two presentations of stimulus series per experiment; series randomized separately for each subject
- 10 subjects in Exp. 1; 15 subjects in Exp. 2; 4 subjects in Exp. 3

Experimental Results

- The apparent intensity of an electrocutaneous stimulus increases with increasing current at a very steep rate. When the data are plotted on log-log coordinates, the slope of the power function fit to the data is close to 3.5, i.e., the perceived magnitude of the electrical stimulus grows approximately as the electric current raised to the exponent 3.5. Estimate values in Fig. 1 were rescaled so that 1.0 equalled perceived magnitude of 0.3-mA current.

Variability

For Exp. 2, interquartile ranges for estimates of the mean are from 1.5-5.5 dB re the geometric mean; these are greater than those usually obtained from magnitude estimates of other types of stimuli. No information on variability was given for Exps. 1 and 3.

Repeatability/Comparison with Other Studies

A similar slope is found for cross-modality matching of current pulses to auditory loudness and to vibration (Ref. 2). Most experimenters have not found an exponent as high as 3.5 for magnitude growth of electrocutaneous stimuli.

Key References

1. Rollman, G. B. (1974). Electrocutaneous stimulation. In F. A. Geldard (Ed.), *Cutaneous communication systems and devices* (pp. 38-51). Austin, TX: Psychonomic Society.

2. Stevens, S. S. (1959). Cross-modality validation of subjective scales of loudness, vibration, and electric shock. *Journal of Experimental Psychology*, 57, 201-209.

*3. Stevens, S. S., Carton, A. S., & Shickman, G. M. (1958). A scale of apparent intensity of electric shock. *Journal of Experimental Psychology*, 56, 328-334.

Cross References

3.125 Electrocutaneous stimulation: effect of exposure duration on sensitivity;

Handbook of perception and human performance, Ch. 12, Sect. 8.2

3.201 The Vestibular System

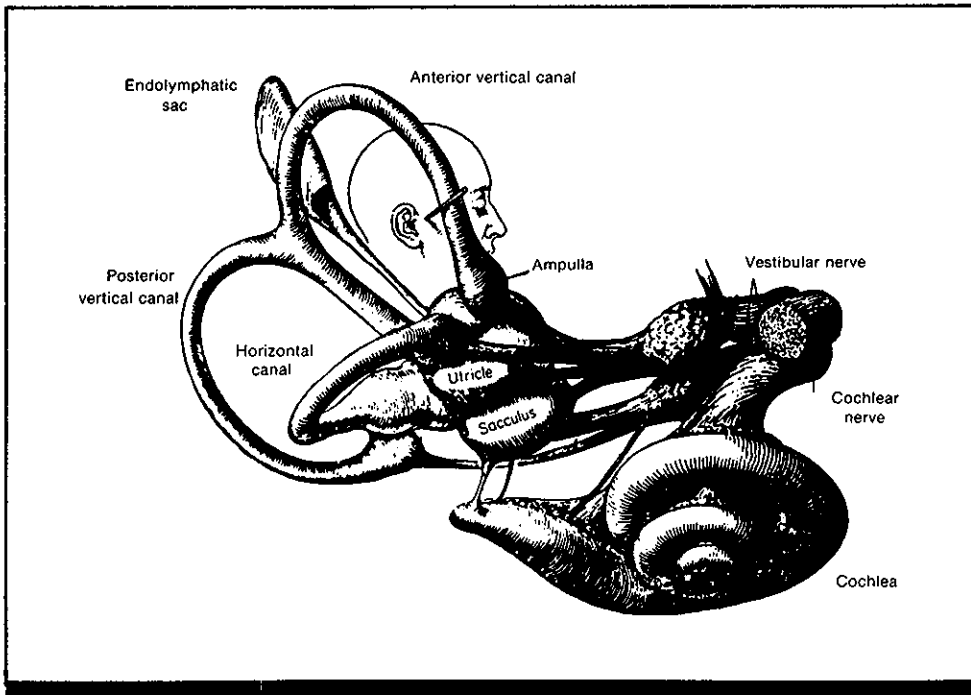

Figure 1. Diagram of the inner ear showing the vestibular apparatus, the cochlea, and their associated nerves. (From Ref. 4, based on Ref. 3)

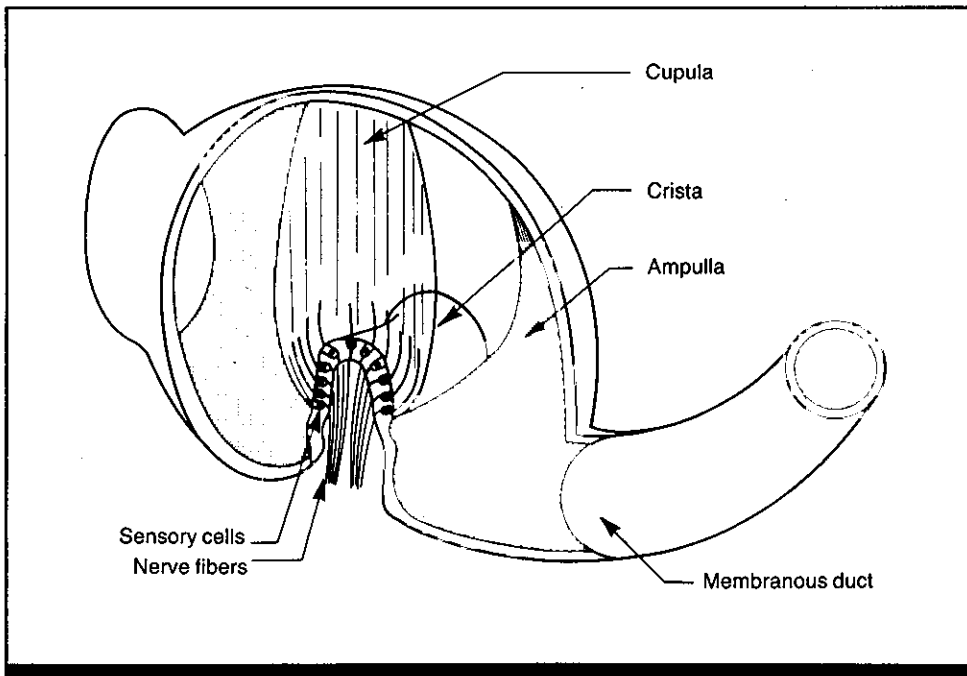

Figure 2. Cut-away view of an ampulla of a semicircular duct. (From Ref. 5)

Key Terms

Ampulla; cilia; cristae; cupula; endolymph; hand movement; kinocilium; labyrinth; lumen; maculae; otolith organs; saccule; semicircular canals; utricles; vestibular system.

General Description

The sense organs embedded in the temporal bone on each side of the human head are the labyrinthine organs, or the labyrinths. The non-auditory labyrinths comprise the vestibular system, which detects signals arising from head movements, but does not inform us about the state of the external world.

The membranous labyrinth lies within a sculptured cavity, or osseous labyrinth, in the temporal bone. It is composed of the vestibular apparatus and the cochlea, the organ of hearing. They share a cavity known as the inner ear and are connected, but the cochlea, which is sensitive to acoustic vibration, has an entirely different structure and function from the vestibular system, which is sensitive to both angular and linear movement of the head and to its attitude relative to gravity.

The vestibular apparatus (Fig. 1), which is about the size of a pea, is made up of three curved tubes (the semicircular canals) and two sack-shaped otolith organs (the utricle and the saccule). Each of the semicircular canals is sensitive to rotary acceleration of the head about the x-, y-, or z-axis. The saccule and utricle are sensitive to tilt of the head with respect to gravity and linear acceleration of the head. The three canals, roughly orthogonal to each other, open into the utricle, which in turn connects with the saccule below. These interconnecting structures (and the cochlea) are filled with endolymph, a liquid with a low viscosity and anionic composition high in potassium and low in sodium. Between the membranous labyrinth and the bony labyrinth is a fluid called perilymph, which is in ionic (high sodium, low potassium) and osmotic equilibrium with the cerebrospinal fluid.

Semicircular Canals

It is misleading to call the canals "semicircular," because each canal functions as a complete and independent circuit. Near the junction of a canal with the utricle, each elliptical cavity, or lumen, swells to form the ampulla (Fig. 2). Across the floor of the ampulla lies a saddle-shaped ridge, the crista ampullaris, which contains the sensory cells. Extending from the crista transversely across the ampulla is the cupula, a gelatinous mass which invests the cilia (the specialized sensory receptors) and forms a seal across the ampulla. This prevents the free circulation of endolymph within the canal, but allows a small displacement of endolymph that deflects the cilia (CRef. 3.203).

The three canals are the anterior-superior, which has a radius of curvature of ~ 2.2 mm, and the posterior-inferior and the lateral (or horizontal), each with a radius of curvature between 1.6 and 1.8 mm. The mean diameter of the lumen of the canals is 0.3 mm. When the head is tilted forward ~ 30 deg, the plane of the lateral ducts is horizontal and the planes of the anterior and posterior ducts are ap-

proximately vertical and ~ 45 deg from the sagittal and coronal planes (CRef. 5.701). The anterior canal on one side of the head is nearly parallel to, and thus forms a working pair with, the posterior canal on the other side (Fig. 3a). The sensory cells of each ampulla are optimally stimulated by an angular acceleration acting in the plane of that duct, so that any angular head movement alters activity in a pair of ducts, one on each side of the head. This pairing of the canals allows resolution of many otherwise ambiguous sensory inputs from the vestibular system, which operates on a difference signal from the two sides that is probably computed at the level of the vestibular nuclei.

Otolith Organs

Both the utricle and saccule contain ciliated sensory end organs located on their inner walls. These maculae are complexly curved, like a cupped hand, but the principal plane of the utricular macula is roughly parallel to the plane of the lateral canal (Fig. 3b). The saccular macula's plane is more or less parallel to the sagittal plane of the head (CRef. 5.701) and perpendicular to the utricular macula. The ciliated cells of the maculae are also invested by a gelatinous structure, but above it is the otolith (or statoconical) membrane (with an area of $1.5\text{--}2.0$ mm²) containing a packed layer of calcium carbonate crystals whose specific gravity is 2.74, three times that of endolymph (CRef. 3.202).

Sensory Cells

Both the cristae and maculae contain sensory cells; a bundle of 60-100 cilia (hair cells) projects from each sensory cell. A transverse section through the cilia shows a roughly hexagonal pattern, within which one cilium, the kinocilium, is longer and more complex in structure. The other cilia are graded in length, with the shortest being farthest from the kinocilium (Fig. 4). The majority of these hair cells have a resting discharge that increases when the cilia are deflected toward the kinocilium and decreases when the cilia are deflected away from the kinocilium. Afferent messages about head position are transmitted to the vestibular nuclei and beyond to the cerebellum and cerebral cortex.

Functions

In the normal course of maintaining posture, input from the vestibular system interacts with visual information and somatosensory inputs from the muscles and joints. The vestibular system is concerned with the detection of signals arising from movements of the head. The utricle is sensitive to the magnitude and direction of linear acceleration and the canals to the magnitude and direction of rotary acceleration, although there is some overlap. In addition, the vestibular system plays a large role in preserving vision during head movement (CRef. 1.910).

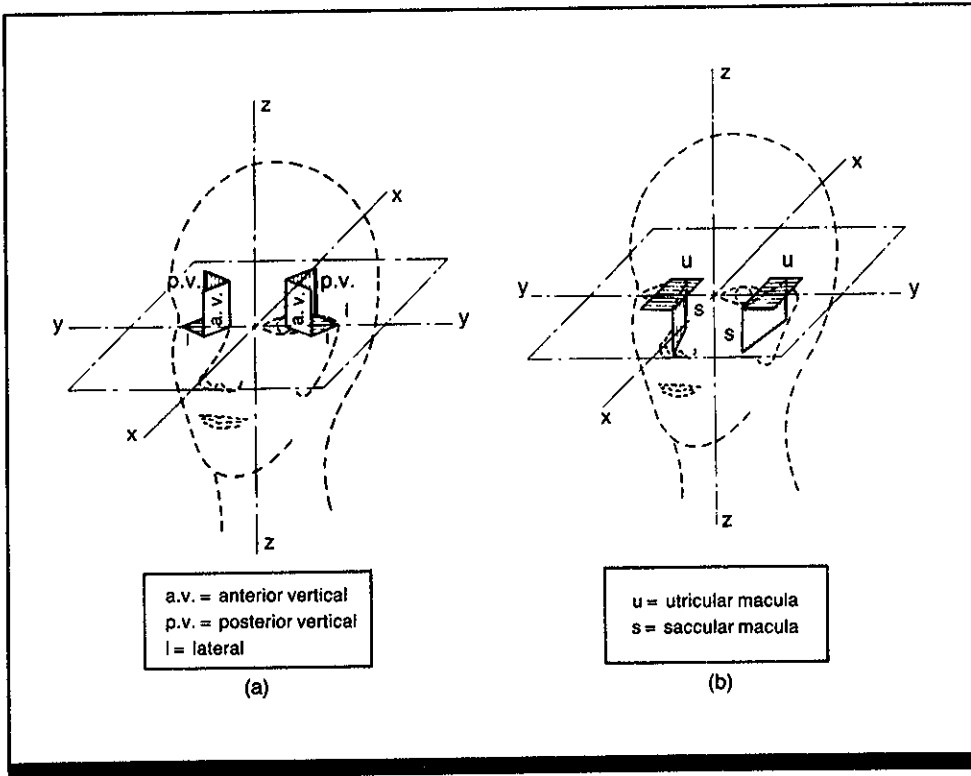

Figure 3. Diagram of principal planes of (a) the semicircular ducts and (b) the maculae. (From Ref. 1)

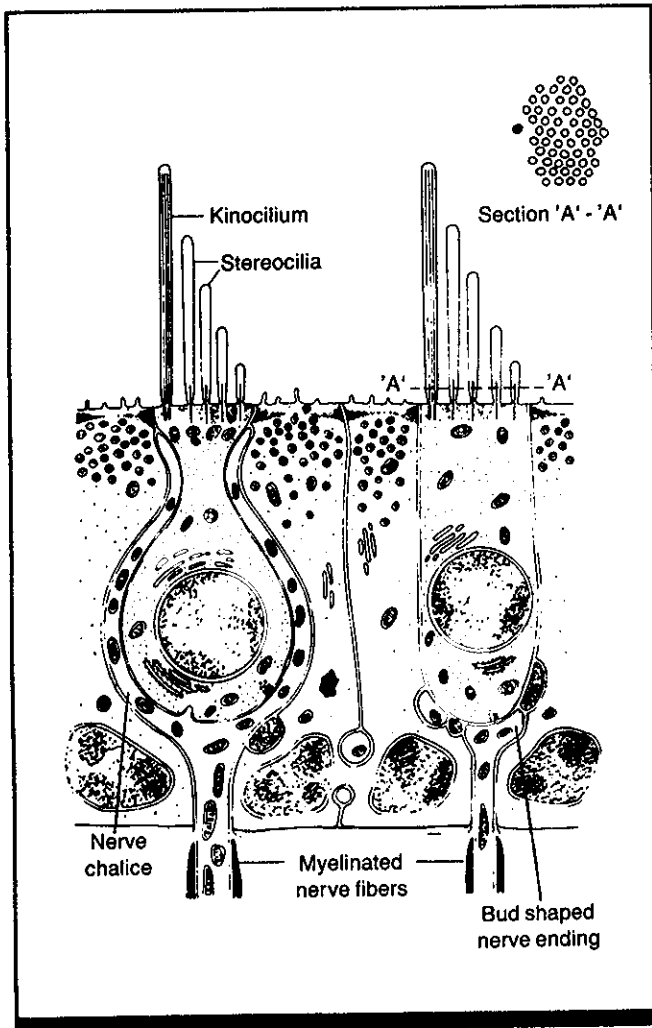

Figure 4. Structure of the sensory cells of the cristae and maculae. (From Ref. 2)

Key References

1. Benson, A. J. (1982). The vestibular sensory system. In H. B. Barlow & J. D. Mollon (Eds.), *The senses* (pp. 333-368). Cambridge, England: Cambridge University Press.

2. Engström, H., Bergström, B., & Ades, H. W. (1972). Macula utriculi and macula sacculi in the squirrel monkey. *Acta Otolaryngologica*, 301 (Suppl.), 75-126.

3. Hardy, M. (1934). Observations on the innervation of the macula sa-

culi in man. *Anatomical Record*, 59, 403-478.

*4. Howard, I. P. (1986). The vestibular system. In K. R. Boff, L. Kaufman, & J. P. Thomas (Eds.), *Handbook of perception and human performance: Vol. 1. Sen-*

sory processes and perception. New York: Wiley.

5. Lindeman, H. H. (1969). Studies on the morphology of the sensory regions of the vestibular apparatus. *Ergebnisse der Anatomie*, 42, 1-113.

Cross References

1.910 Control-systems-analysis model of visual and oculomotor functions in retinal image stabilization;

3.202 Dynamics of the otolith organs;

3.203 Dynamics of the semicircular canals;

3.204 Synergism of body rotation and head tilt;

3.210 Vestibular illusions;

5.701 Terminology used to describe head and body orientation;

Handbook of perception and human performance, Ch. 14, Sect. 2

3.202 Dynamics of the Otolith Organs

Key Terms

Maculae; otoliths; saccule; statoconial membrane; torsion-pendulum equation; utricle; vestibular system

General Description

The sack-shaped otolith organs, the utricle and saccule, are part of the human vestibular system (CRef. 3.201) and are found in the inner ear. On the floor of the utricle and on the inner wall of the saccule are the maculae, which contain sensory end organs called hair cells or cilia. The utricular macula is more or less horizontal with respect to the head, and the saccular macula (tilted inward from the vertical by 20 deg) is roughly perpendicular to the utricular macula (Fig. 1). Like the vestibular canals, the otolith organs are filled with endolymph.

The cilia of the macula protrude into a gelatinous mass, the statoconial (or otolithic) membrane, which contains crystals of calcium carbonate (the statoconia or otoliths) whose specific gravity (2.74) is almost three times that of endolymph (Fig. 2). In effect, the cilia support the weight of the statoconial layer so that when the plane of a macula is horizontal, there is little distortion of the cilia because the force of gravity is perpendicular to the macula. It takes considerable force to deflect the bristles of a brush by pushing straight down on them, but a slight shearing force, parallel to the surface of the brush, deflects the bristles easily. In the same way, when the macula is tilted out of the horizontal, or linear acceleration occurs, the cilia are deflected by the effective weight of the otoliths occurring as a shearing force (Fig. 3). The deflection of the cilia from their equilibrium position changes the basic rate of firing of the cells. Because each hair cell has a directional sensitivity (patterns of directional sensitivity are mapped as arrows in Fig. 1), linear acceleration or tilt of the head relative to gravity in a given direction will cause some cells to be excited, some to be inhibited, and others not to change from the base rate. The hair cells exhibit an increase in sensitivity with frequency of head tilt, making them responsive to both acceleration and rate of change of acceleration.

Dynamics

If the density of the endolymph is assumed to be 1, then the excess mass of the statoconial membrane (β) is its mass m minus the mass of the same volume of endolymph, and can be expressed as:

$$\beta = m \frac{(\rho - 1)}{\rho}$$

where ρ is the density of the statoconial membrane.

The shearing force acting on an otolith organ is equal to the product of the excess mass of the statoconial membrane and the linear acceleration acting in the plane of the macula (α). This is opposed by several kinds of resistance: (a) elas-

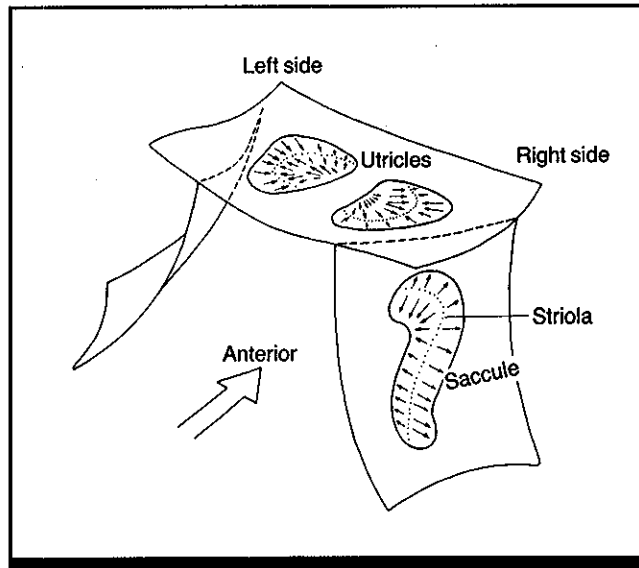

Figure 1. Orientation of the maculae in the otolith organs, with arrows indicating polarization. (From Ref. 5)

tic, or position-dependent (k); (b) viscous, or velocity-dependent (r); and (c) acceleration-dependent (m).

Where m is the effective mass of the otolith membrane and x is the linear displacement of the otoliths, the differential equation for the torsion-pendulum can be used to express the relationship between the force acting on the otoliths and their displacement:

$$\beta\alpha = kx + r(dx/dt) + m(d^2x/dt^2)$$

Direct measurements of these constants have been made in fish (Ref. 2); the statoconial membrane of the saccule was displaced $\sim 33 \mu\text{m}$ by a tangential force induced on the mass by $1 g_n$ (9.8 m/sec^2). The human threshold for saccule stimulation is $\sim 0.005 g_n$ (Ref. 3). If similar values hold for humans, the threshold displacement of the saccule would be $\sim 0.15 \mu\text{m}$ —a distance within molecular dimensions. This suggests that the crucial event in afferent stimulation is a deformation of organic molecules.

Time Constants

The statoconial membrane appears to be critically damped and fully displaced within 5 msec of the application of a constant tangential force as measured during oscillatory stimulation. Unlike the recovery time of the vestibular canals, the otolith membrane returns to its normal position very rapidly after stimulus offset. Since these time constants of latency and recovery are inferred from behavioral measures, there may be some confounding of other neural response times with those of the peripheral otolith organs.

Constraints

- Signals from the otolith organs have a fundamental ambiguity. The effect of horizontal linear acceleration (a) is indistinguishable from the effect of tilting the head through an angle whose sine is a (Fig. 3).

Key References

1. Benson, A. J. (1982). The vestibular sensory system. In H. B. Barlow & J. D. Mollon (Eds.), *The senses*. England: Cambridge University Press.

2. deVries, H. (1950). The mechanics of the labyrinth otoliths. *Acta Otolaryngologica*, 38, 262-273.

*3. Howard, I. P. (1986). The vestibular system. In K. R. Boff, L. Kaufman, & J. P. Thomas

(Eds.), *Handbook of perception and human performance. Vol. 1. Sensory processes and perception* (Chap. 11). New York: Wiley.

4. Iurato, S. (1967). Light microscope features. In S. Iurato (Ed.), *Submicroscopic structure of the*

inner ear. New York: Pergamon Press.

5. Malcolm, R., & Melvill Jones, G. (1970). A quantitative study of vestibular adaptation in humans. *Acta Otolaryngologica*, 70, 126-135.

Cross References

3.201 The vestibular system;
3.203 Dynamics of the semicircular canals;

3.206 Methods of investigating linear acceleration;
3.210 Vestibular illusions

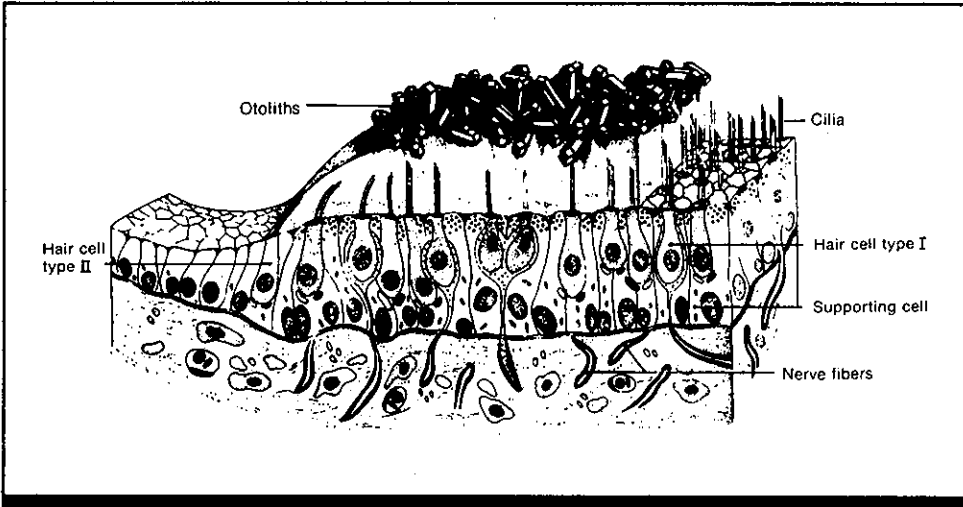

Figure 2. Diagrammatic representation of the detailed structure of the macula showing calcite crystals in statoconial membrane. (From Ref. 4)

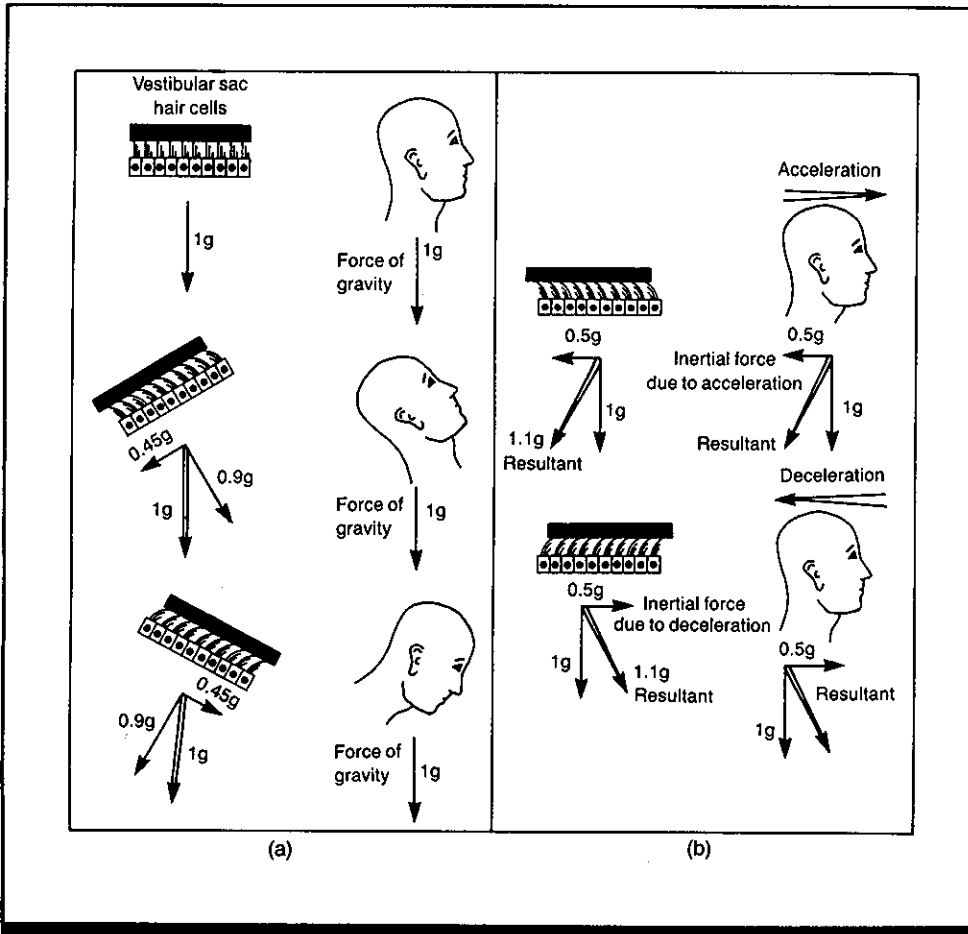

Figure 3. Comparison of the forces acting on the otolith organs (a) during tilt about the y-axis and (b) during linear acceleration and deceleration in the x-axis of the head. (From Ref. 1)

3.203 Dynamics of the Semicircular Canals

Key Terms

Bode plots; cupula; semi-circular canals; torsion-pendulum equation; vestibular canals; vestibular system

General Description

The three semicircular canals on each side of the head allow us to detect rotation or angular acceleration. When the head turns in a given direction, the endolymph lags behind the movement of the canal walls (in the plane of the head movements), and thus flows in a direction opposite that of head rotation. The diaphragm-like cupula, which seals the ampulla of the canal, is pushed by the endolymph and bulges in the direction opposite rotation. The endolymph and cupula are displaced through angle θ ; when the head rotates with angular acceleration α , the force acting on the cupula is αH , which is the product of acceleration (α) and the moment of inertia of the endolymph and cupula (H).

The Torsion-Pendulum Equation

The relation of the force acting on the cupula to the amount of cupula displacement can be expressed (to a first approximation) by the differential equation for the torsion pendulum:

$$\alpha H = K\theta + r(d\theta/dt) + H(d^2\theta/dt^2) \quad (1)$$

where H equals the moment of inertia, or coefficient of mass-dependent resistance of the cupula and endolymph (estimated to be $2.4 \times 10^{-4} \text{ g/cm}^2$); K equals the coefficient of elastic, or position-dependent resistance, and r equals the coefficient of viscous, or velocity-dependent resistance. The viscous resistance coefficient can be calculated from Poiseuille's law ($r = 16V^2R^3$, where V is viscosity of endolymph and R is the radius of the canal torus) as 0.043 dynes/cm/sec. The coefficient of elasticity of the cupula has not been calculated directly. Because cupula displacement is at most only 10 μm , it is difficult to observe.

Implications of Canal Characteristics

The lumen (bore) of a vestibular canal is 0.3 mm in mean diameter. The mass of the endolymph is small and viscous resistance is high even at moderate velocities; the elasticity of the cupula is minimal. Thus the first and last terms of Eq. (1) become so small when compared to the second term that the equation can be rewritten:

$$\alpha H = r(d\theta/dt). \quad (2)$$

H and r are constants, so $d\theta/dt$ is proportional to α ; that is, the angular velocity of the cupula is proportional to head acceleration. Integrating both sides of the relationship with respect to time demonstrates that the angular displacement of a cupula is proportional to the head's angular velocity.

The semicircular canals are integrating accelerometers or angular speedometers, detecting angular velocity at normal velocities and durations of head rotations. For slow head rotation, the viscous resistance becomes smaller than the inertial resistance; the third term of Eq. (1) becomes dominant and the system's response becomes proportional

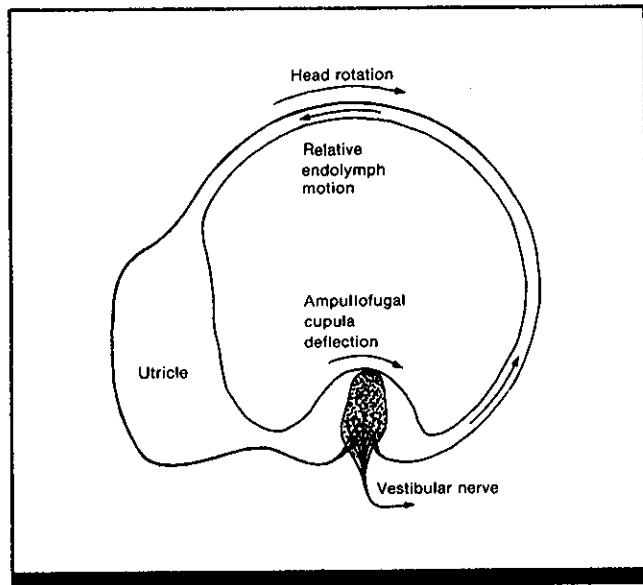

Figure 1. Vestibular canal and complete fluid circuit. (From J. H. Milsum & G. Melvill Jones, *Dynamic asymmetry in neural components of the vestibular system, Annals of the New York Academy of Sciences, 156*. Copyright 1969 by New York Academy of Sciences. Reprinted with permission.)

to the head's acceleration. For head rotations lasting <3 sec, integration of the velocity signals in the central nervous system yields accurate estimations of the angle through which the head has turned.

Advantages of the canal's small bore and high viscous resistance are that they:

- prevent turbulence in endolymph flow;
- provide viscous damping to prevent oscillation;
- reduce endolymph flow so the cupula deflection is small in a range where its characteristics are most linear; and
- reduce latency of cupula deflection to keep it in phase with head rotation.

Parameters of Physical Response of Canals

Latency is the time it takes for the cupula to deflect to $1/e$ of its maximum value, where e is the base of the natural logarithm. This time is given by the ratio H/R , which is the inertial time constant of the cupula (also known as the short time constant); values are in the 3-5 msec range.

Recovery time is the time it takes for the cupula to return to its normal resting position after stimulus offset; it is represented by r/k , or the elastic time constant (the long time constant); although difficult to measure, it has been recorded as 3.8 sec in monkeys.

Phase-lag can be determined by assuming that the cupula system is a linear system; then the relation of input to output can be analyzed by Fourier analysis. The input signal is a function relating head velocity and time, and the output is displacement of the cupula as a function of time. The phase shift of the system is defined as the phase angle be-

tween the input and output functions for a defined frequency of input, with both functions superimposed on a time abscissa; phase shift varies as a function of the input frequency and can be shown graphically in a phase Bode plot (Fig. 2b); this defines the extent to which cupula displacement leads or lags head velocity as a function of the frequency of head oscillation.

Gain is the ratio of cupula displacement to head velocity and indicates the sensitivity of the system. When measures of input and output differ, an arbitrary rate can represent a gain of one and the other values are relative gain; a plot of log gain as a function of input frequency is a Bode plot of gain (Fig. 2a). For a linear control system, a transfer function describes the phase shift and gain over input frequency. Although the transfer function of the cupula is embodied in the torsion-pendulum equation, it is usually expressed in a simpler form known as the Laplace transform (denoted by s);

$$\theta/\alpha(s) = 1/[(T_1s + 1)(T_2s + 1)]$$

where θ is the gain of the system (displacement of the cu-

pula per unit head acceleration) and T_1 and T_2 are the short and long time constants, respectively.

The range of input frequencies of head rotation for which cupula displacement is a function of head velocity is 0.5-5.0 Hz. Phase of displacement relative to head velocity is constant over this range (Fig. 2). Below this range, cupula displacement leads and, at very low frequencies, reaches a limiting value of 90 deg. At this point, displacement becomes proportional to head acceleration. Above this range of natural head movements, displacement lags up to a limiting value of 90 deg. At this point, cupula displacement and head displacement are proportional. The gain of the system is estimated to be at a maximum and constant over the range of movements for which the phase lag is zero. Gain falls off outside this range, indicating that the system is less sensitive.

When a person turns voluntarily, acceleration is followed immediately by deceleration and the two opposed deflections of the cupulae (and the opposed afferent signals) tend to cancel. The case is very different for imposed rotations (CRef. 3.205).

Key References

- *1. Howard, I. P. (1986). The vestibular system. In K. R. Boff, L. Kaufman, & J. P. Thomas (Eds.), *Handbook of perception and human performance: Vol. 1. Sensory processes and perception*. New York: Wiley.
2. Melvill Jones, G., & Milsum, J. H. (1965). Spatial and dynamic aspects of visual fixation. *IEEE Transactions on Biomedical Engineering*, BME-12, 54-62.
3. Milsum, J. H., & Melvill Jones, G. (1969). Dynamic asymmetry in neural components of the vestibular system. *Annals of the New York Academy of Sciences*, 156, 851-871.

Cross References

- 3.201 The vestibular system;
- 3.202 Dynamics of the otolith organs;
- 3.204 Synergism of body rotation and head tilt;
- 3.205 Methods for investigating the effects of rotation;
- 3.209 Long-term adaptability of the vestibular system;
- 3.210 Vestibular illusions

Figure 2. Bode plot showing gain and phase theoretically derived from the simple torsion-pendulum equation of cupula dynamics. (From G. Melvill Jones & J. H. Milsum, Spatial and dynamic aspects of visual fixation, *IEEE Transactions in Biomedical Engineering*, BME-12. Copyright © 1965 by IEEE. Reprinted with permission.)

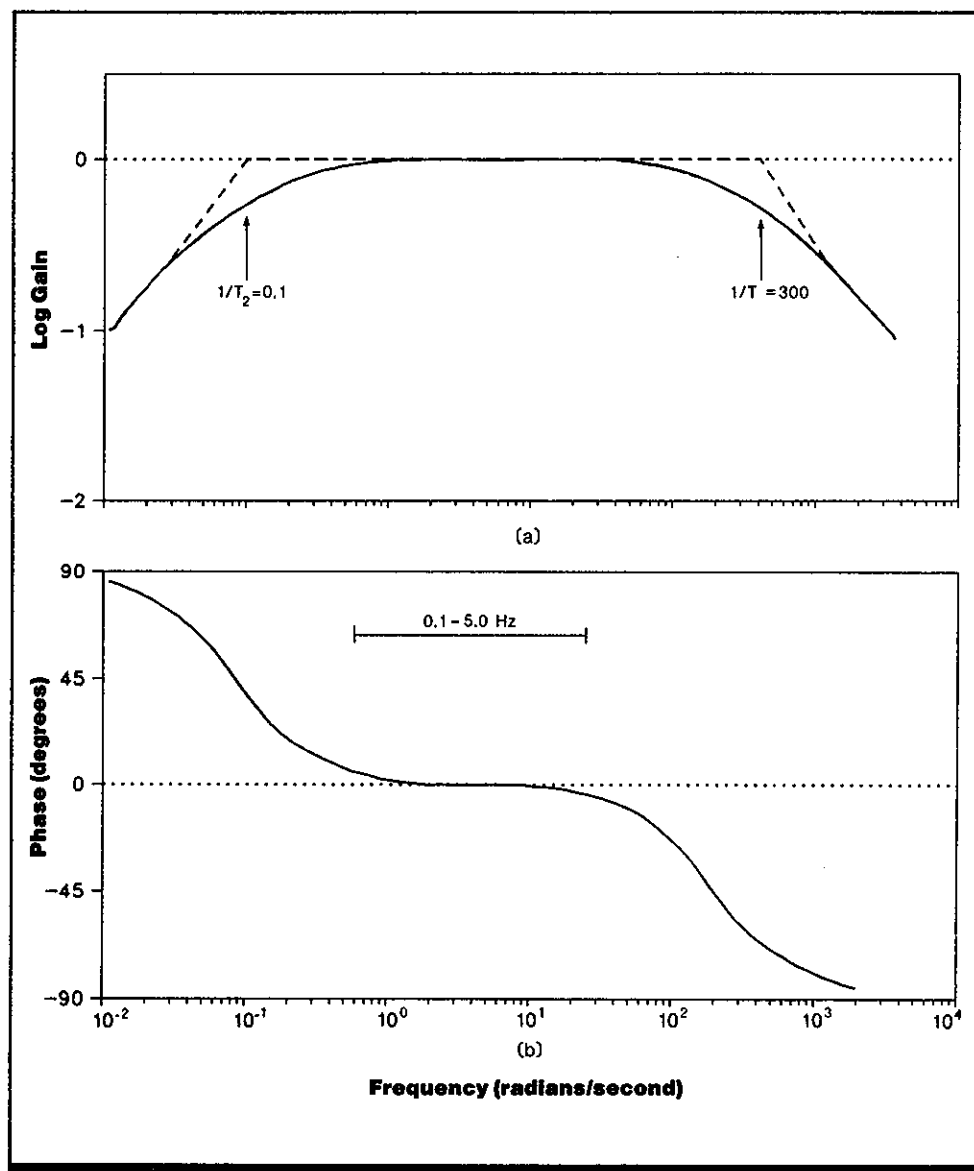

3.204 Synergism of Body Rotation and Head Tilt

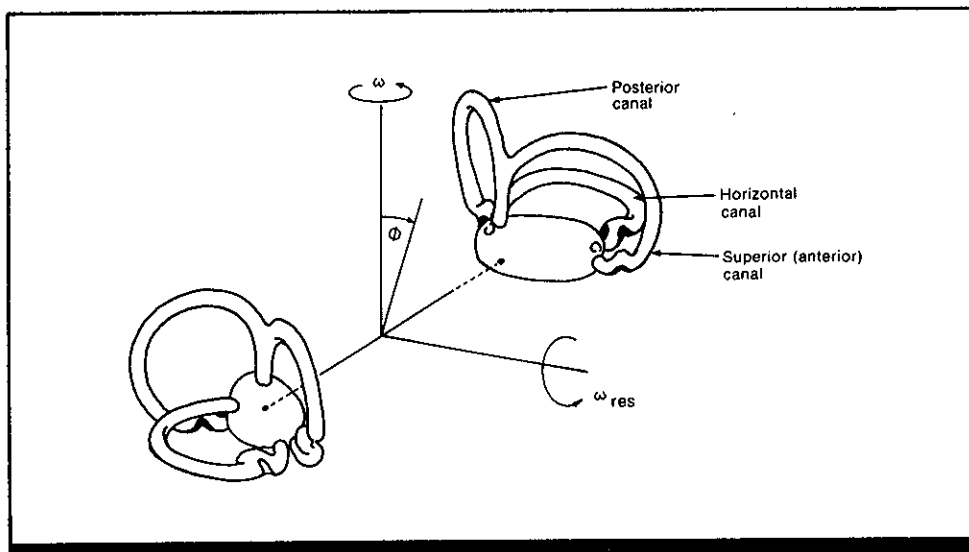

Figure 1. Cross-coupling between head tilt and body rotation; see text for explanation. Angle θ indicates the degree of head tilt during rotation of velocity ω around a vertical axis. (From Ref. 1)

Key Terms

Body rotation; cupula; head tilt; semicircular canals; vestibular canals; vestibular system

General Description

Subjects rotating around a vertical axis who move their heads through a *forward* angle sense *lateral* head movement, and feel as though they are falling sideways. This synergism of head tilt and body rotation results from the effects of changing momentum on the semicircular canals. During vertical rotation, the lateral and horizontal semicircular canals move at angular velocity ω ; the vertical canals are not affected because they are in the plane of rotation. Endolymph in the horizontal and lateral canals lags and deflects the cupula in the direction opposite the rotation (CRef. 3.203).

If the head tilts forward through angle θ , the vertical canals move into the plane of rotation and become subject to a momentum component of that rotation, $\omega \sin \theta$. At the

same time, the horizontal canals lose a fraction of the original momentum equal to $\omega \cos \theta$, leaving them with momentum of $\omega(1 - \cos \theta)$. Momentum from each of the canals adds as vectors do; just after the head reaches its new position, the resultant momentum over the three canals exceeds ω . The resulting momentum excess (ω_{res}) drives the endolymph clockwise, which causes a counterclockwise sensation equivalent to a stimulus intensity:

$$\omega_{res} = \omega \{(1 - \cos \theta)^2 + 2 \sin^2 \theta\}^{1/2}$$

For a forward head tilt and vertically rotating body, ω_{res} has been calculated for different angles of tilt (Table 1). ω_{res} denotes a factor by which the actual ω of rotation must be multiplied to produce the sensation of falling over.

Constraints

- The movement has to be made within 2 sec for the effect to occur.
- The tilting movement has to be made before the vestibular canals habituate to the rotation for these calculations to apply (CRef. 3.205).

Key References

*1. Groen, J. J. (1961). The problems of the spinning top applied to the semicircular canals. *Confinia Neurologica (Basel)*, 21, 454-455.

2. Howard, I. P. (1986). The vestibular system. In K. R. Boff, L. Kaufman, & J. P. Thomas (Eds.), *Handbook of perception and human performance: Vol. 1. Sensory processes and perception*. New York: Wiley.

Cross References

3.201 The vestibular system;
3.203 Dynamics of the semicircular canals;
3.205 Methods for investigating the effects of rotation;

3.206 Methods for investigating linear acceleration;
3.208 Threshold for angular acceleration;
3.209 Long-term adaptability of the vestibular system;
3.210 Vestibular illusion

Table 1. Relationship of angle of tilt to factor changing rotation momentum. (From Ref. 1)

Angle	ω_{res}
30	0.72
45	1.05
60	1.32
90	1.73
180	2.00

3.205 Methods for Investigating the Effects of Rotation

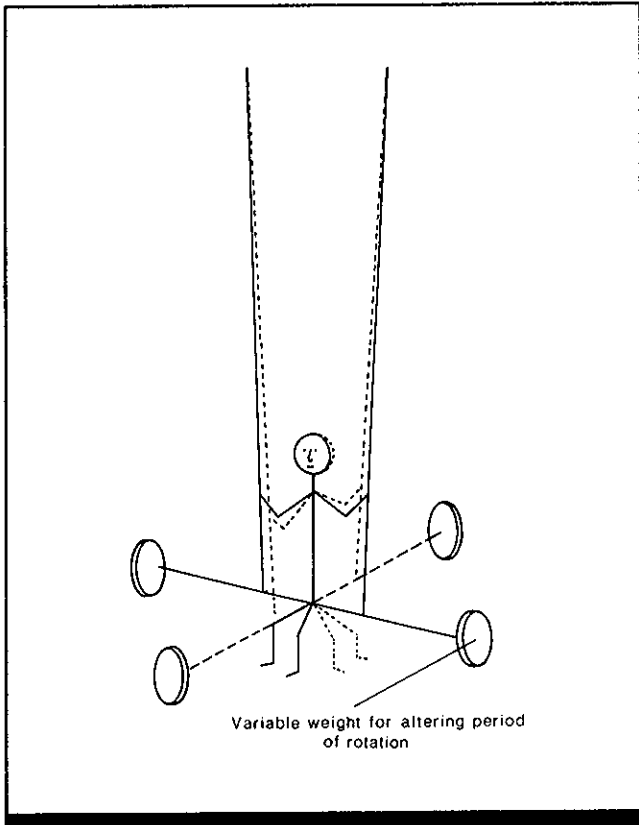

Figure 1. The torsion swing, which provides sinusoidal rotation of the subject's body. (From Ref. 2.)

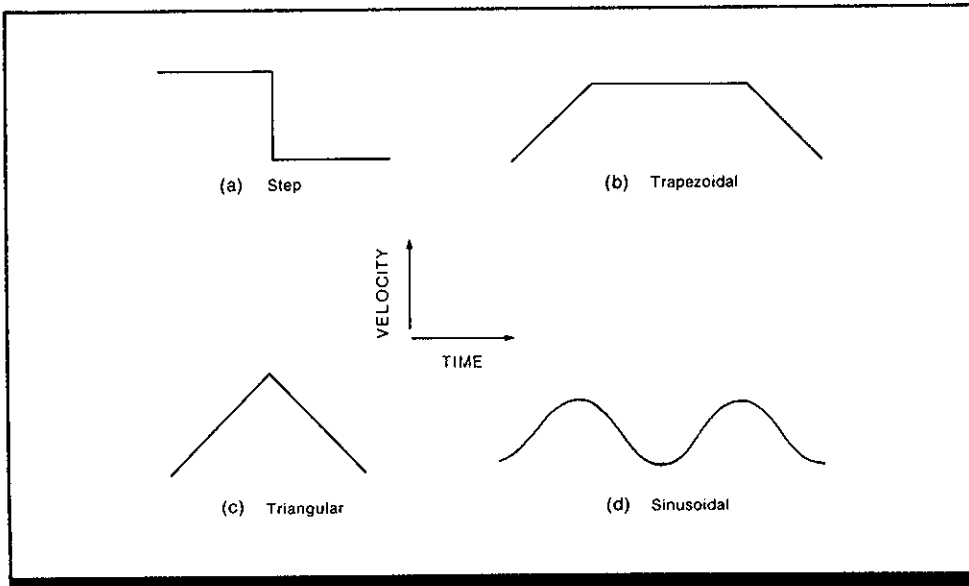

Figure 2. Four velocity profiles used as inputs to control rotary acceleration and deceleration of subjects. (From Ref. 1)

Key Terms

Bárány chair; cupulometry; Fourier analysis; oculogyral effect; postrotatory; perrotatory; semicircular canals; torsion swing

General Description

Thresholds for rotary acceleration (CRef. 3.208) are determined by perrotatory and postrotatory procedures. Postrotatory measures are easier to use because the subject has come to rest after rotation, and there are no vibrations or noise present. In contrast, perrotatory measures are recorded while the subject is rotating. Response to rotation can be measured by responses such as nystagmic eye movements, which are involuntary rapid movements of the eyeball, and the oculogyral effect, which is the apparent movement of a point of light in the dark. Subjective judgments may also be used.

Perrotatory Procedures

For perrotatory measures, a subject's response (e.g., the reflex nystagmic response of the eye) is recorded while the subject is experiencing rotary acceleration. A rotational device that allows a wide range of steady accelerations or oscillates over a wide range of frequencies is used to rotate the subject; it may also be possible to set the rotation axis to any angle with respect to the vertical or to the subject's body axis. A rotating Bárány chair or the torsion swing (Fig. 1) is used for routine clinical testing.

One not-very-successful approach has been to use a step-velocity profile (Fig. 2a) that provides an impulsive acceleration-deceleration to control the rotational device. Other stimulus profiles are also used. A pseudo-random sequence of rotational accelerations (analogous to white noise in acoustics) has been designed to serve the same purpose as

the step profile. The trapezoidal profile (Fig. 2b) separates the effects of accelerative and decelerative impulses and provides a very high level of control of each. The triangular (Fig. 2c) and sinusoidal (Fig. 2d) velocity profiles are used because they resemble the stimulus profiles of ordinary head movements.

Postrotatory Procedures

For postrotatory procedures, the subject is quickly decelerated to zero velocity after having been rotated at a steady velocity long enough for perrotatory effects to cease. Responses to the decelerative impulse (e.g., nystagmic eye movements) are recorded during the immediate postrotatory period. Thresholds cannot be determined with this procedure (using the Bárány chair) because of the large deceleration; therefore cupulometry was developed to provide threshold information. A subject is rotated at different steady velocities and postrotatory data are collected for decelerations of various amplitudes. The cupulogram is the function yielded by plotting the duration of the postrotatory response against the amplitude of the decelerative impulse. The ideal cupulogram is a linear function and the subject's threshold for rotary acceleration is quantified by the intercept of the function on the impulse magnitude axis. Ideally, the slope of the function quantifies the long time constant of the vestibular response (CRef. 3.203). However, the function varies with practice and with response measure (e.g., the oculogyral effect or the nystagmic response) (CRef. 3.208).

Constraints

- All response measures include neural processing as well as the influence of semicircular canal processing.

Key References

1. Howard, I. P. (1986). The vestibular system. In K. R. Boff, L. Kaufman, & J. P. Thomas

(Eds.), *Handbook of perception and human performance: Vol. 1. Sensory processes and perception*. New York: Wiley.

2. Jongkees, L. B. W. (1975). On the physiology and examination of the vestibular labyrinths. In R. F. Naunton (Ed.), *The vestibular system*. New York: Academic Press.

Cross References

3.201 The vestibular system;
3.203 Dynamics of the semicircular canals;
3.204 Synergism of body rotation and head tilt;

3.208 Threshold for angular acceleration;
3.209 Long-term adaptability of the vestibular system;
3.210 Vestibular illusions

3.206 Methods for Investigating Linear Acceleration

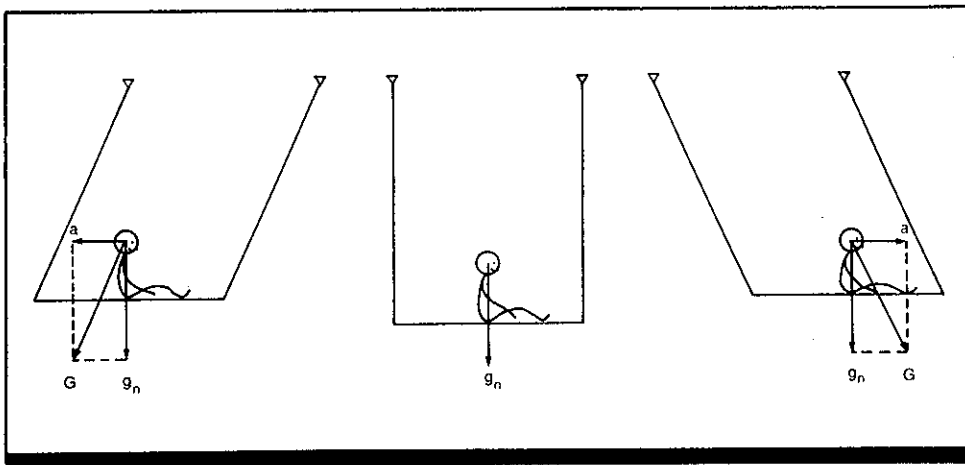

Figure 1. The parallel swing used to stimulate the otolith organs sinusoidally. (From Ref. 3)

Key Terms

Body tilt; centrifugation; Coriolis effects; linear acceleration; otolith organs; semicircular canals; spatial disorientation; vestibular canals; vestibular system

General Description

Humans are constantly exposed to a linear accelerative force of $1 g_n$ (9.8 m/sec^2), considered the baseline in determining thresholds for linear acceleration. Linear acceleration thresholds can be determined by moving a subject to and fro over a fixed linear path to produce an oscillating accelerative force, or by exposing a subject to a constant linear accelerative force which differs in direction and/or magnitude from a baseline condition, usually the natural force of gravity acting through a specified axis of the body (CRef. 5.701).

Oscillating Linear Acceleration

For oscillating acceleration over a fixed linear path, the velocity profile is usually sinusoidal, although others are possible. A convenient apparatus for producing sinusoidal oscillation without rotary stimulation is the parallel swing (Fig. 1). With sinusoidal oscillation, velocity is 90 deg out of phase with displacement and with acceleration. Peak acceleration is given by $f^2\theta$, where f is the frequency (in radians/sec) and θ the amplitude, and occurs momentarily twice during each cycle. The periodic variation in the magnitude of the resultant linear vector is small for moderate acceleration, compared with the variation in its duration.

Constant Linear Acceleration

Three procedures for achieving constant linear acceleration are: (a) to tilt the subject in a specific plane through a specified angle; (b) to rotate the subject in a centrifuge; and (c) to accelerate the subject along a linear track in a defined direction with respect to gravity and to the subject's body axis.

Tilting

If the subject is upright with the utricular macula horizontal, the direction of tilt specifies the direction of the linear ac-

celerative vector acting on the statoconial membrane (CRef. 3.202). The sine of the angle of tilt specifies the magnitude of the shear force (CRef. 3.202, Fig. 3).

When a subject is tilted, those semicircular canals (CRef. 3.201) which lie on the plane of the tilt are activated, as are the otolith organs. Providing an additional cue to tilt, the vestibular canal response may contaminate the linear threshold determination. However, if the effect of varying only the direction of a linear vector is of interest, tilting is preferable to centrifuging.

Centrifugation

When a subject at a distance r from the center of rotation is rotated at angular velocity ω , a centrifugal acceleration vector of magnitude $\omega^2 r$ is produced and the result of the orthogonal centrifugal and gravitational forces is a linear vector of magnitude $\{(\omega^2 r)^2 + g_n^2\}^{1/2}$ acting on an angle of arc $\tan \omega^2 r/g_n$ to the vertical.

For small values of $\omega^2 r$, the main factor is its change in direction because the increase in vector magnitude is small. As long as the body maintains its natural orientation to gravity, the effects of low magnitude centrifugation on the otolith organs are similar to those produced by tilting the body through arc $\tan \omega^2 r/g_n$, but the activation of the semicircular canals does not occur because there are not accelerative forces acting in the plane of force displacement. Every time the centrifuge rotates, the subject's body rotates about a vertical axis; the plane of this rotation is orthogonal to the linear vector displacement, but the turning sensation may be distracting. There is also the danger that Coriolis effects may occur if the head is allowed to move (CRef. 3.204).

For large values of $\omega^2 r$, the increase in the resultant force becomes the dominant factor. The centrifuge provides the best method for exposing subjects to forces in excess of $1 g_n$ for long periods of time. Another advantage is that the

subject's body axis may be inclined to any angle to the resultant force. The same distracting effects of rotation and Coriolis forces are still possible. After centrifuge rotation has started, it takes several seconds before sensations of body tilt are felt; when the stationary body is tilted, effects are felt immediately.

Tracking

If a subject is accelerated at α m/sec² along a horizontal track, the direction of the resultant linear vector is displaced from the vertical in the direction of motion through $\arctan \alpha/g_n$. The component vectors are orthogonal, so the magnitude of the resultant vector is increased to $\{\alpha^2 + g_n^2\}^{1/2}$. Along a vertical track, the magnitude of force is changed to $g_n + \alpha$ or $g_n - \alpha$ for downward or upward motions.

Long, smooth linear tracks are difficult and expensive to construct. A constant stimulus value can be maintained for only short periods as velocity becomes great. There are,

however, no rotary stimuli, so that if the track is smooth and acceleration is free from detectable transients, such tracks provide the least contaminated procedure for measuring thresholds for linear acceleration.

Responses

Subjects are asked to make different judgments, depending on the stimulus procedure.

- For oscillation or track procedures, subjects report the first sensation of motion, or indicate the direction of motion.
- For tilting and centrifugation, subjects report when the body first feels tilted relative to the initial position.

Thresholds for the first sensation of motion are lower than for reporting direction of motion. Thresholds for direction of motion are lower than for sensation of tilt (Ref. 4).

Constraints

Regardless of the procedure employed, thresholds for linear acceleration cannot be considered as otolith thresholds, because somesthetic receptors for touch and pressure are also stimulated and a verbal response requires other neural activity.

Key References

1. Benson, A. J. (1982). The vestibular system. In H. P. Barlow, & J. L. Mollon (Eds.), *The senses*. New York: Cambridge University Press.

*2. Howard, I. P. (1986). The vestibular system. In K. R. Boff, L. Kaufman, & J. P. Thomas (Eds.), *Handbook of perception and human performance: Vol. 1. Sensory processes and perception*. New York: Wiley.

3. Jongkees, L. B. W. (1975). On the physiology and examination of the vestibular labyrinths. In R. F. Naunton (Ed.), *The vestibular system*. New York: Academic Press.

4. Jongkees, L. B. W., & Groen, J. J. (1946). The nature of the vestibular stimulus. *Journal of Laryngology*, 61, 529-541.

Cross References

3.201 The vestibular system;
3.202 Dynamics of the otolith organs;

3.203 Dynamics of the semicircular canals;
3.204 Synergism of body rotation and head tilt;

3.205 Methods for investigating the effects of rotation;
3.207 Threshold for linear acceleration;

3.209 Long-term adaptability of the vestibular system;
3.210 Vestibular illusions;
5.701 Terminology used to describe head and body orientation

3.207 Threshold for Linear Acceleration

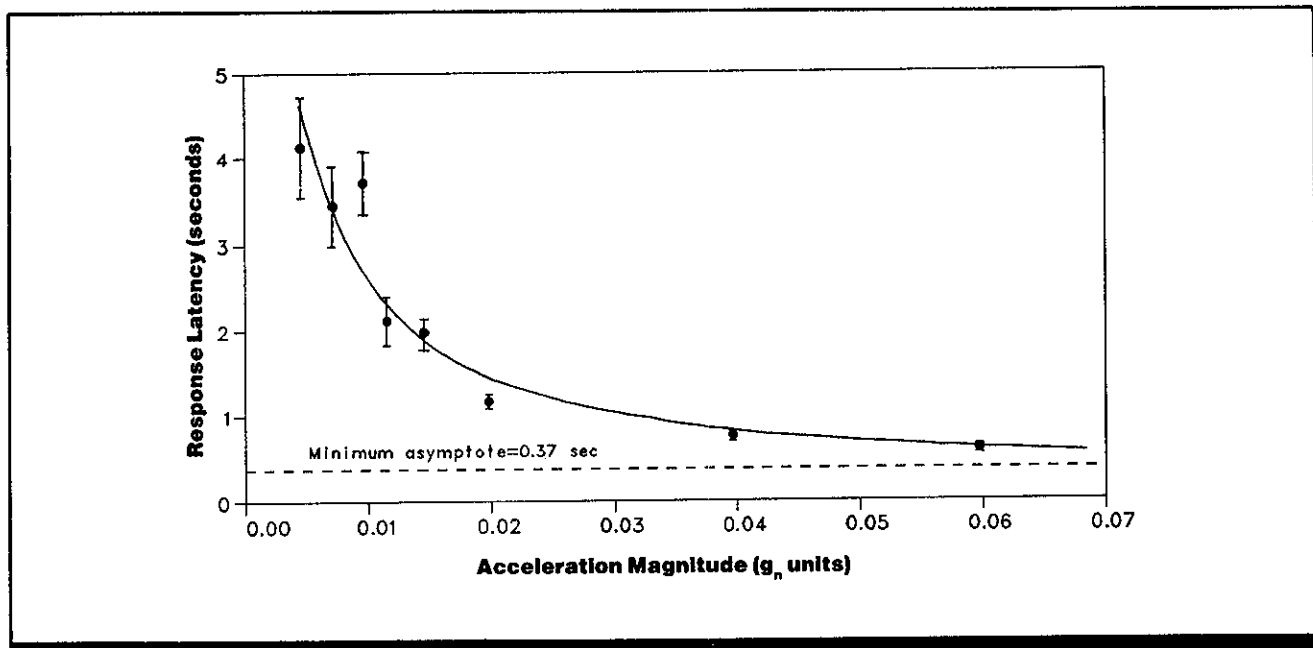

Figure 1. Latency of detection of vertical acceleration as a function of rate of acceleration (8 subjects; bars give standard errors). (From Ref. 3)

Key Terms

Linear acceleration; magnitude estimation: otolith organs; self-motion

General Description

The least contaminated procedure for determining thresholds for linear acceleration is to accelerate subjects along a smooth linear track (CRef. 3.206). A subject accelerated along a vertical track reports the direction of motion as soon as possible over several values of acceleration. That acceleration at which response latency greatly increases is considered the absolute threshold. Response latency (Fig. 1) lengthens considerably at an acceleration of $<0.01g_n$. From the function relating acceleration to latency, it is inferred that a particular velocity has to be achieved before movement is reported; the mean value of this constant linear velocity is 2.16 m/sec (Ref. 3).

Table 1 shows human thresholds for linear acceleration under different experimental conditions. Subjects can be accelerated along vertical or horizontal tracks; body position can be altered so that the x-, y-, or z-axis (CRef. 5.701) is parallel to the direction of motion. The period of oscillatory motion can also be varied. Although subjects' response can take several forms, the response mode for thresholds shown here was to report the first sensation of motion. The table gives the mean or range of threshold values for peak acceleration at which subjects accelerated in various positions

and directions reliably detected motion. A threshold value of 10 cm/sec^2 is equivalent to a utricular shear force of $\sim 0.01 g_n$ per unit mass. Except for the unusually high threshold for seated subjects firmly strapped in, the thresholds do not vary much, considering all the variables. Thresholds are $\sim 6 \text{ cm/sec}^2$, regardless of direction and body axis.

Magnitude-estimation methods measure how sensations vary with stimulus magnitude, revealing how the system responds at suprathreshold levels. Subjects estimate the magnitude of the stimulus, and the logarithms of the estimates are plotted against the logarithm of stimulus magnitude. For the function $R = kS^n$, where R is the response magnitude and S is the stimulus magnitude, the value of the exponent (n) is the slope of the function. For a large n value (a steep slope), small changes in stimulus magnitude produce large differences in sensation. Using the physical displacement of the parallel swing (CRef. 3.206) as the stimulus magnitude, the mean exponent of the power function varied between 1.45 and 2.2. The exponent was smaller for vertical head position than for tilted head position; the exponent increased after a prolonged period of oscillation (Ref. 5). Rotary acceleration (CRef. 3.208) produced exponents of 1.3-1.5.

Table 1. Human thresholds for the detection of linear acceleration along either a vertical or a horizontal track with the indicated period of oscillation. (Adapted from *Handbook of perception and human performance*)

Posture of Subjects	Axis of Oscillation	Period of Oscillation (sec)	Number of Subjects	Maximum Acceleration at Threshold (cm/sec ²)	References
Upright	Vertical	7	1	10-12	Ref. 2
Firmly seated facing movement	Horizontal	2-8	2	20-25	Ref. 6
Seated facing movement, but free to move	Horizontal	2-8	2	8	Ref. 6
Standing facing movement	Horizontal	2-8	2	8	Ref. 6
Standing sideways to movement	Horizontal	2-8	2	5	Ref. 6
Supine	Horizontal	3	13	8.2	Ref. 7
Prone	Horizontal	3	13	7.0	
Supine	Vertical	4	7	6.3	Ref. 8
Prone	Vertical	4	7	5.5	
Prone	Horizontal	2.6	6	6-12	Ref. 4

Constraints

- Subjects are more likely to be confused about the direction of vertical motion than that of horizontal motion.
- Thresholds for first sensation of motion are lower than for detection of direction of motion (CRef. 3.206).

Key References

- *1. Howard, I. P. (1986). The vestibular system. In K. R. Boff, L. Kaufman, & J. P. Thomas (Eds.), *Handbook of perception and human performance: Vol. 1. Sensory processes and perception*. New York: Wiley.
2. Mach, E. (1875). *Grundlinien der Lehre von der Bewegungsempfindungen*. Leipzig: Engleman.

3. Melvill Jones, G., & Young, L. R. (1978). Subjective detection of vertical acceleration: A velocity-dependent response. *Acta Otolaryngologica*, 85, 45-53.
4. Parker, D. E., Gullledge, W. L., Tubbs, R. L., & Littlefield, V. M. (1978). A temporary threshold shift for self-motion detection following sustained oscillating acceleration. *Perception & Psychophysics*, 23, 461-467.

5. Parker, D. E., Wood, D. L., Gullledge, W. L., & Goodrich, R. L. (1979). Self-motion magnitude estimation during linear oscillation: Changes with head orientation and following fatigue. *Aviation, Space & Environmental Medicine*, 50, 1112-1121.
6. Travis, R. C., & Dodge, R. (1928). Experimental analysis of the sensorimotor consequences of passive oscillation, rotary rectilin-

- ear. *Psychological Monographs*, 38, Whole No. 175.
7. Walsh, E. G. (1962). The perception of rhythmically repeated linear motion in the horizontal plane. *British Journal of Psychology*, 53, 439-445.
8. Walsh, E. G. (1964). The perception of rhythmically repeated linear motion in the vertical plane. *Quarterly Journal of Experimental Physiology*, 49, 58-65.

Cross References

- 3.201 The vestibular system;
3.202 Dynamics of the otolith organs;
3.206 Methods for investigating linear acceleration;

- 3.208 Threshold for angular acceleration;
3.210 Vestibular illusions;
5.701 Terminology used to describe head and body orientation;

- 10.901 Sustained acceleration (+G_z): effect on visual performance;
10.906 Sustained acceleration (+G_z): effect on vision and consciousness

3.208 Threshold for Angular Acceleration

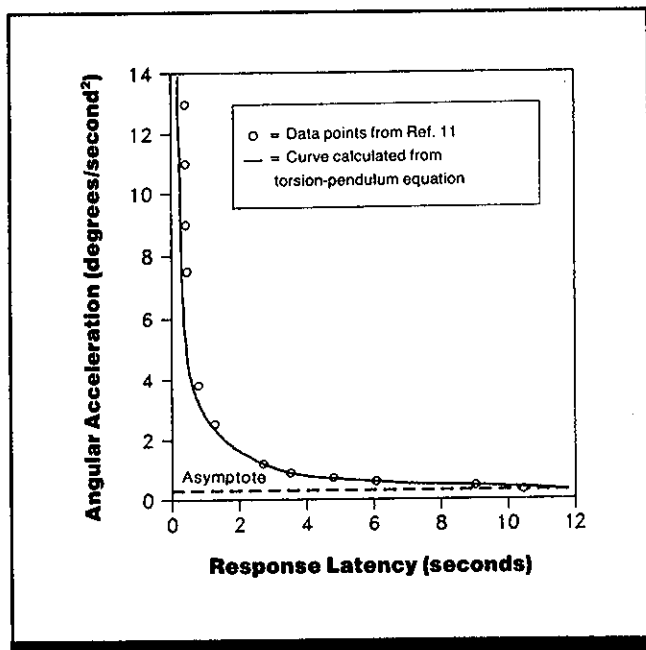

Figure 1. Latency of detection of rotation as a function of rotary acceleration. (From Ref. 7)

Key Terms

Angular acceleration; apparent movement; body rotation; cupula; magnitude estimation; Mulder's Constant; nystagmus; oculogyral effect; semicircular canals; spatial disorientation; torsion-pendulum equation; vestibular system

General Description

With a rotating chair or torsion swing, angular acceleration thresholds can be assessed by rotating a subject over a range of accelerations or oscillating a subject over a range of frequencies. Thresholds can be defined as the point at which (a) subject reports a feeling of rotation; (b) nystagmus occurs; or (c) the oculogyral effect (apparent movement of a stationary target) is seen.

The methods of stimulus presentation in these acceleration threshold experiments vary. Psychophysical methods include the method of limits, in which angular acceleration is increased gradually or in discrete steps until the subject responds or reports a sensation. Different stimulus magnitudes are presented in random order with the method of constant stimuli, thereby overcoming the problem of anticipatory responding. A more efficient modification of the method of constant stimuli is the double staircase method: stimulus values above and below the estimated threshold alternate at random, with values moved closer to or away from that estimated value, depending on the subject's previous two responses. The stimulus values eventually converge at the same value, the actual threshold.

Magnitude-estimation procedures have been used to relate the perceived velocity of rotation to various parameters of the stimulus. Values of the exponent relating sensation

magnitude to stimulus magnitude have been found to vary between 1.3 and 1.5. Because the vestibular system adapts to maintained acceleration, this value falls as the sensitivity of the system declines. (CRef. 3.209).

If a constant suprathreshold stimulus is applied, it still requires time before it is detected; the minimum duration of stimulation is an inverse function of stimulus magnitude. Mulder's Constant states that the product of acceleration and stimulus duration for a threshold stimulus is constant. Although the inverse relation between acceleration and duration holds, the product has been found to be a linearly increasing function of stimulus duration (Ref. 4) rather than a constant. Extrapolation from the function relating response latency to stimulus magnitude can determine the magnitude at which latency approaches infinity. This asymptotic acceleration value is often used as a threshold measure. Response latencies (shown as open circles in Fig. 1; see Ref. 11) have an asymptotic acceleration of $\sim 0.3 \text{ deg/sec}^2$. The curve in Fig. 1 was derived from the torsion-pendulum equation describing cupula dynamics (CRef. 3.203 and Ref. 7).

The table lists method of response, psychophysical method, stimulus, exposure time, subject number, thresholds, and sources of more detailed information.

Table 1. Measure of thresholds for angular acceleration. (From Ref. 10)

Response	Method	Stimulus	Exposure	Number of Subjects	Threshold acceleration (deg/s ²)	References
First reports of rotation		Rotating chair	30 sec	30	Range 0.28-2.0 Mean 0.8	Ref. 6
	Staircase	Rotating chair	10 sec	92	Range 0.05-3.18 Mean 0.44	Ref. 3
Oculogyral illusion		Human centrifuge	80 sec with response assessed every 20 sec	5	Mean 0.12	Ref. 5
	Staircase	Rotating chair	10 sec	92	Range 0.03-0.59 Mean 0.11	Ref. 3
	Staircase	Rotating chair	20 sec	300	Range 0.02-0.95 Median 0.1	Ref. 12

Key References

- Clark, B. (1967). Thresholds for the perception of angular acceleration in man. *Aerospace Medicine*, 38, 443-450.
- Clark, B., & Stewart, J. D. (1968). Comparison of three methods to determine thresholds for perception of angular acceleration. *American Journal of Psychology*, 81, 207-216.
- Clark, B., & Stewart, J. D. (1972). The power law for the perception of rotation by airline pilots. *Perception & Psychophysics*, 11, 433-436.
- Doty, R. L. (1969). Effect of duration of stimulus presentation on the angular acceleration threshold. *Journal of Experimental Psychology*, 80, 317-321.
- Graybiel, A., Kerr, W. A., & Bartley, S. H. (1948). Stimulus thresholds of the semicircular canals as a function of angular acceleration. *American Journal of Psychology*, 61, 21-36.
- Groen, J. J., & Jongkees, L. B. W. (1948). The threshold of angular acceleration perception. *Journal of Physiology*, 107, 1-7.
- Guedry, F. E. (1974). Psychophysics of vestibular sensation. In H. H. Kornhuber (Ed.), *Handbook of sensory physiology* (Vol. VI/2). New York: Springer-Verlag.
- Hallpike, C. S., & Hood, J. D. (1953). The speed of the slow component of ocular nystagmus induced by angular acceleration of the head. *Proceedings of the Royal Society, Series B*, 141, 216-221.
- Hilding, A. C. (1953). Studies on the otic labyrinth III: On the threshold of minimum perceptible angular acceleration. *Annals of Otology, Rhinology & Laryngology*, 62, 5-14.
- *10. Howard, I. P. (1986). The vestibular system. In K. R. Boff, L. Kaufman, & J. P. Thomas (Eds.), *Handbook of perception and human performance: Vol. 1. Sensory processes and performance*. New York: Wiley.
- Meiry, J. L. (1965). *The vestibular system and human dynamic space orientation*. Unpublished doctoral dissertation, Massachusetts Institute of Technology, Cambridge, MA.
- Miller, E. F., & Graybiel, A. (1975). Thresholds for the perception of angular acceleration as indicated by the oculogyral illusion. *Perception & Psychophysics*, 17, 329-332.
- Tumarkin, I. A. (1937). Some observations on the function of the labyrinth. *Proceedings of the Royal Society of Medicine*, 30, 599-610.

Cross References

- 3.113 Vibrotactile stimulation: summation of perceived magnitude;
- 3.119 Tactile, auditory, and visual shifts in perceived target location due to stimulus interactions;
- 3.201 The vestibular system;
- 3.203 Dynamics of the semicircular canals;
- 3.205 Methods for investigating the effects of rotation;
- 3.209 Long-term adaptability of the vestibular system;
- 3.210 Vestibular illusions;
- 10.902 Acceleration of body rotation: effect on visual acuity

3.209 Long-Term Adaptability of the Vestibular System

Key Terms

Habituation; nystagmus; recalibration; semicircular canals; spatial orientation; vestibular system

General Description

For eye movements triggered by vestibular stimulation, signals from the visual scene are used to trim the gain of the system (which operates in the dark in a feed-forward condition without correction). The vestibular control system apparently adjusts to changes during an individual's growth, and vision must also provide the feedback necessary for such long-term, or parametric, adjustments. The vestibular system also adapts in other ways. Habituation is the gradual removal of inappropriate responses, such as the cessation of sea sickness on a long sea journey; recalibration is the initiation of new response patterns to stimulus conditions. There appears to be habituation to various combinations of anom-

alous visual-vestibular signals; the point at which habituation should more properly be called recalibration is not clear.

Most attempts to define the time course of recalibration use the objective measure of changes in nystagmus, or involuntary eye movements, but some subjective response measures are used. The table describes situations where adaptability has been studied, shows the time course of adaptation as well as whether one adjustment is considered habituation or recalibration, and cites sources of additional information. Short-term cupula restoration and sensory adaptation have been added to the table for comparative purposes.

Constraints

- Under normal conditions, head acceleration is followed immediately by deceleration and the two opposed deflections of the cupula (and the two neutral events) tend to cancel, leaving little residual deflection or aftereffects.

Key References

1. Collins, W. E. (1964). Task-control of arousal and the effects of repeated unidirectional angular acceleration of human vestibular responses. *Acta Otolaryngologica, Suppl. 190*, 1-34.
2. Dowd, P. J., & Cramer, R. L. (1967). Habituation transference in Coriolis acceleration. *Aerospace Medicine*, 38, 1103-1107.
3. Gauthier, G. M., & Robinson, D. A. (1975). Adaptation of the human vestibular-ocular reflex to magnifying lenses. *Brain Research*, 92, 331-335.
4. Gonshor, A., & Melville Jones, G. (1973). Changes of human vestibulo-ocular response induced by vision-reversal during head rotation. *Journal of Physiology*, 234, 102-103.
5. Gonshor, A., & Melville Jones, G. (1976). Short-term adaptive changes in the human vestibulo-ocular reflex. *Journal of Physiology*, 256, 361-379.
6. Guedry, F. E. (1964). Visual control of habituation of complex vestibular stimulation in man. *Acta Otolaryngologica*, 58, 377-389.
- *7. Howard, I. P. (1986). The perception of posture, self motion, and the visual vertical. In K. R. Boff, L. Kaufman, & J. P. Thomas (Eds.), *Handbook of perception and human performance: Vol. 1. Sensory processes and perception*. New York: Wiley.
8. Stratton, G. M. (1897). Upright vision and the retinal image. *Psychological Review*, 4, 182-187.
9. Stratton, G. M. (1897). Vision without inversion of the retinal image. *Psychological Review*, 4, 341-360.

Cross References

- 3.201 The vestibular system;
 3.202 Dynamics of the otolith organs;
 3.203 Dynamics of the semicircular canals;
 3.205 Methods for investigating the effects of rotation;
 3.210 Vestibular illusions

Table 1. Adaptability of the vestibular system.

Situation	Adaptation: Habituation or Recalibration	Time Course	References
Recovery from motion sickness during a long sea voyage represents habituation of vertigo-induced nausea (when noxious visual-vestibular conflict repeats without consequences)	Long-term habituation	From incidental observations, occurs within a few days	Ref. 7; CRef. 3.205
Men rotated sinusoidally for 1 hr each day for 3 days show no evidence of response decrement.	Lack of habituation (there is no conflict between visual-vestibular input and no post-rotary effects when oscillatory motion is used)		Ref. 4
After repeated uni-directional rotation, postrotatory nystagmus, subjective reaction, and oculogyral illusion show response decrements	Thought to be due to central factors rather than fatigue of sensory adaptation; rate of habituation is higher for some responses than for others; habituation is specific to direction inducing it	May last up to 1 month	Ref. 1
After days in the rotating room with Coriolis effects every time head is tilted, subjects still experience nystagmus, dizziness, and nausea; however, symptoms subside when head tilt is practiced in a given direction	Suggests active recalibration of system After leaving rotating room, subjects experience an opposite-direction nystagmus when head is tilted in practiced direction		Ref. 6 Ref. 2
Room speed has to be increased very gradually and many head motions made at each velocity, but there is adaptation at eventual rotation of 10 rpm			
After 6 days of wearing spectacles that reversed and inverted the visual scene, the sensation of anomalous motion of the visual scene disappears	Recalibration	6 days	Ref. 5
When optical reversal of visual scene is maintained for 2-27 days, the gain of the slow phase of nystagmus induced by rotation of the body in the dark decreases steadily. During the second week, a nystagmus of reversed phase begins to appear and the gain gradually improves	Results during second week suggest recalibration	By end of 7 days was almost zero 7-14 days	Refs. 8, 9
Normal vision is restored after reversing spectacles have been worn	Nystagmus returns to normal after 2 hr	2 hr	
Wearing magnifying spectacles (factor of 2 magnification)	Visual stability is regained after 4 days; there is also a 70% increase in the gain of nystagmus	4 days	Ref. 3
As a short-term effect, when subject is rotated at constant velocity for longer than 20 sec, the endolymph slips in the canal, so that the cupula returns to normal relation with canal. There is a reverse effect for deceleration. However, when acceleration is continued, vestibular input weakens but rapidly recovers when acceleration stops	Cessation of velocity stimulus; neural adaptation at peripheral and possibly control levels for acceleration	20 sec for return to normal during constant-velocity rotation; acceleration effect occurs within seconds during any period of continued constant acceleration and recovers within seconds or, at most, minutes after acceleration stops	CRef. 3.203

3.210 Vestibular Illusions

Key Terms

Aubert effect; constant acceleration; Coriolis effects; elevator illusion; illusory tilt; inversion illusion; linear acceleration; Müller effect; oculogravic illusion; otolith organs; semicircular canals; spatial disorientation; vestibular illusions; vestibular system; visual-vestibular interaction

General Description

The vestibular system consists of the otolith organs (the utricle and saccule) and the semicircular canals (CRef. 3.201). Although there is some overlap in function, in general the otoliths detect linear acceleration and the canals detect angular acceleration. Certain dynamics of the system (CRefs. 3.202, 3.203) lead to illusions of two general kinds: (a) some motions are misunderstood, and

thus there is an illusory perception of the position or motion of the body; and (b) some motions cause visual illusions.

The table lists those illusions caused by otolith stimulation and those caused by canal stimulation, describes the illusion, explains the cause or inducing condition, and lists entries or sources where more information is available.

Constraints

- The position illusions do not generally occur unless there is an absence of visual cues.
- A small percentage of the normal population does not experience some of these illusions.

Key References

1. Howard, I. P. (1986). The perception of posture, self motion, and the visual vertical. In K. R. Boff, L. Kaufman, & J. P. Thomas

(Eds.), *Handbook of perception and human performance: Vol. 1. Sensory processes and perception.* New York: Wiley.

Cross References

1.652 Orientation-selective effects on contrast sensitivity;
1.923 Factors influencing duration of postrotary nystagmus;
1.957 Factors affecting counterrotation of the eyes;

3.201 The vestibular system;
3.202 Dynamics of the otolith organs;
3.203 Dynamics of the semicircular canals;

3.204 Synergism of body rotation and head tilt;
5.607 Factors affecting target localization;
5.705 Visual factors influencing postural stability;
5.708 Illusory self-inclination;

5.802 Illusory spatial displacements;
5.804 Body tilt: effects on perceived target orientation (the Aubert and Müller Effects);
6.304 Role of reference frames in perception

Table 1. Illusory sensations associated with stimulation of the vestibular system. (Adapted from Ref. 1)

Name	Description	Cause/Inducing Condition	Reference
Stimulation of Otoliths			
Illusory tilt	Linear acceleration is interpreted as tilt of the body	A shear force acting on the otolith maculae caused by linear acceleration is ambiguously interpreted as the shear force caused by tilt in the absence of visual cues for disambiguation	Ref. 1
Unperceived tilt	Subject with body aligned with gravito-inertial force fails to perceive tilt of vehicle	The otolith maculae are normal to the gravito-inertial force caused by a banking plane, and in the absence of visual cues to disambiguate, this is interpreted as the normal upright	
Inversion illusion	In zero gravity conditions (or in a prone position) a person may feel upside down	The upside-down position is that in which discharge from the utricles is lowest, so the absence of gravity and low utricle discharge are misinterpreted	Ref. 1

Name	Description	Cause/Inducing Condition	Reference
Coriolis effects	A linear motion toward or away from the center of rotation of a rotating vehicle causes tangential displacement of gravito-inertial force	In a centrifuge, linear movement and rotary motion are not perceived, but are combined into one illusory percept	
Oculogravic illusions	Motions that change the magnitude and direction of gravito-inertial force are experienced as the apparent displacement of visual objects	After prolonged rotation in centrifuge in the dark, when the gravito-inertial force has been changed in direction and magnitude without the sensation of rotation, the force on the otolith organs is interpreted as normal gravity so that visual objects are interpreted as displaced	Ref. 1
Elevator illusion	Change in the magnitude of gravito-inertial force produces the apparent elevation or depression of visual objects	This is one cause of an oculogravic illusion in which only the magnitude of the force on the otoliths causes objects to appear to be higher or lower	Ref. 1
Müller effect	When the body (or head) is tilted slightly to the left or right in the dark, a vertical or horizontal line appears to tilt in the same direction as body tilt	Degree of body (or head) tilt must be between 20 and 60 deg from upright with no visible cues to establish truly vertical	CRef. 5.802
Aubert effect	When the body (or head) is tilted far to the left or right in the dark, a vertical or horizontal line appears to tilt in the opposite direction to the body tilt	Degree of body (or head) tilt must be between 70 and 90 deg from upright with no visible cues to establish truly vertical	CRef. 5.802
Stimulation of Canals			
Unperceived constant velocity	Rotation of constant velocity is undetected by the vestibular system	After ~20 sec of constant velocity, the cupula resumes its normal position with respect to its canal	Ref. 1
Postrotatory sensations	Negative: deceleration causes sensations of turning and falling in the opposite direction to the prolonged rotation Positive: sensation of moving in same direction as the original induced prolonged rotation occurs after negative (anti-phase) sensation subsides	Subject is decelerated after prolonged rotation has allowed the cupula to return to normal position Inertial force of endolymph causes cupula to deflect in opposite direction at deceleration; effect lasts ~30 sec Due to recovery from vestibular adaptation, the in-phase secondary phase has a longer recovery time of ~80 sec, but has been overshadowed by negative anti-phase	Ref. 1; CRef. 1.923
Adaptation to constant acceleration	Sensation that velocity is not increasing	There is a decrease in the effective strength of stimulation during a period of maintained acceleration	Ref. 1
Cross-coupling effects (Coriolis)	Sensation of falling to one side	If head is tipped forward as body rotates about a vertical axis, it causes a sensation that one is falling sideways	CRef. 3.204
Oculogyral illusions	Sensation that objects are moving or displaced with respect to head; pilots sometimes report an apparent visual bending of the artificial horizon after strong vestibular inputs during rolling movements	During or after prolonged rotation, the vestibular inputs are interpreted as movements (headcentric) of visual objects, rather than as movements of the head	Ref. 1

3.301 Kinesthesia

General Description

This section deals with the conscious awareness of the relative positions and movements of the limbs and body parts, the sense of effort one experiences with muscle contraction, and the awareness of the force of a muscle contraction. Kinesthesia refers specifically to those sensations that arise from sensors located in the limb or part itself: the muscles, tendons, skin, and the capsules and ligaments of the joints. The term "kinesthesia" is often used interchangeably with "proprioception."

The kinesthetic sense is but one means available for the awareness of the positions and movements of the limbs. One can use visual and tactile cues, or rely on the accuracy and dependability of the motor system to place a limb to a desired position without the need for cues at all. However, without sensory cues, one could not tell whether an act was performed as intended. From the perspective of overall performance, it makes little difference what senses a subject uses to do a task, though knowledge of the mechanisms involved and the effect of different factors, such as vibration, muscle loading, and fatigue, can assist the designer in anticipating changes in performance under new and unusual circumstances, such as the weightlessness encountered in space.

Studies of kinesthesia have dealt mainly with elucidating underlying neural mechanisms; therefore no body of literature explores and documents kinesthetic performance to provide a set of guidelines for the equipment designer. However, these studies provide the designer insight into the methodology used to study kinesthesia plus some data about human performance and factors that can influence the accuracy and reliability of kinesthetic perception.

The senses of limb movement, static-position, force developed by a muscle, and effort are independent senses that involve different mechanisms although they may involve the same receptor populations and neural pathways. Static-position sense derives from the muscle spindle receptors that measure muscle length and rate of change of length. Movement sense derives from both the muscle spindle receptors and receptors in the skin, most of which exhibit only rate responses with little or no static response. The sense of muscle force presumably derives from receptors in the muscle tendons that monitor tension. The sense of effort derives from an internal monitoring of the command signals destined for the muscles and requires no sensory input at all. The sense of muscle force or tension is subtle and is confused with the much more vivid sense of effort; laboratory conditions are needed to distinguish these two senses. Similarly, the awareness of static-position is a subtle awareness that requires careful experimental design to reveal. One should note that most studies of position sense in the literature have tested movement sense and not position sense.

Static-Position Sense and Movement Sense: Methods and Models

- Several methods exist for testing position sense; these include matching one limb to its opposite member (CRefs. 3.311, 3.312, 3.314, 3.319), placing a limb at a

target position established verbally (CRef. 3.309), visually, or kinesthetically (CRef. 3.316), detecting excursions of a joint using movement speed or amplitude as variables (CRefs. 3.302, 3.305, 3.307), or estimating the magnitude of joint excursion (CRef. 3.306). Measurements of "limb-position sense" (CRef. 3.302) almost always test some combination of static-position sense and movement sense. Distinguishing the two senses is difficult (CRefs. 3.302, 3.319); one cannot move a joint without altering its position, and vice versa. Early studies made little distinction between static-movement sense, and used the term "position sense" with imprecise meaning; most studies of "position sense" have measured only movement sense.

- Static-position sense is distinguished from movement sense by moving a joint sufficiently slowly (<1 deg/min) that movement signals from the limb are below threshold for perception, leaving only true position signals (CRef. 3.319). Subjects have no sensation of movement with slow rotations, but they sense changes in alignment.
- Awareness of static-position derives from length receptors in muscles (CRef. 3.322); the lengths of the muscles set the angles of the joints that determine limb position. Spatially tuned receptors in joints were thought to provide static-position sense (CRef. 3.322), but this is unlikely. Receptors in skin (CRef. 3.104) can signal movement of a joint, but not its static-position (CRef. 3.322).
- A memory for limb-position exists that is accurate and stable over long time periods (CRefs. 3.317, 3.319). Tasks that require placing a limb in a previously held position utilize this memory. Whether a similar long duration memory exists for movement, force, or effort is not known.

Performance Characteristics

- Accuracy of matching position (angle) of one joint to its opposite varies with the target position. Mean error is greatest (i.e., there is least accuracy) toward extremes of flexion or extension, and the error is directed toward the mid-position (subject underestimates amount of flexion or extension). However, matching variability (standard deviation) is least (i.e., there is greatest precision) near the extremes (CRef. 3.314). Reproducing a target position with the shoulder using the finger to point to targets on concentric rings in front of the subject produces errors between 1.7 and 5.8 cm (with 70 cm radius) (CRef. 3.316). Using a stylus in one hand to point to a target in the other hand yields smaller errors (median error 8 mm with active placement of the target hand, 18 mm with passive placement) (CRef. 3.316).
- Matching accuracy (mean error) varies considerably between subjects (e.g., between ± 8 deg error for the elbow, 50 subjects) (CRef. 3.314). However, matching precision (standard deviation) about the perceived mean position varies little between subjects (CRefs. 3.314, 3.319).
- Most tests use a single joint (CRef. 3.302), but when more joints are involved, subjects perceive the orientation of the limb more accurately than the angle of a joint (CRef. 3.313).
- Displacement needed to detect joint movement (e.g.,

with 70% correct detections) varies with the speed of the movement (CRefs. 3.304, 3.305, 3.307). Values range from 0.08-1.4 deg as "thresholds" for detection for various joints (CRefs. 3.304, 3.306). However, differences in methods (criteria for detection, subject bias, and speed of rotation) make it difficult to meaningfully compare these values. In general, subjects detect fractional degree excursions with fast movements (>1 deg/sec), but larger excursions (up to several degrees) are needed as speed decreases below 1 deg/sec. The interphalangeal joints of the fingers require larger and faster excursions (CRefs. 3.304, 3.305, 3.307).

- Sensitivity to movement is greater with proximal joints (closer to the torso) than with distal joints (CRef. 3.304), though movement sensitivities are similar if one compares joints on the basis of changes in muscle length rather than joint angle (CRef. 3.305). No right versus left side differences exist; age decreases movement sensitivity (CRef. 3.304).
- Perception of position and movement of the limbs are influenced by a variety of factors (CRef. 3.303), summarized in the following paragraphs.

Influence of Target Location and Direction of Movement

- Accuracy of reproducing a target location with the arm is affected by the location of the target, the direction of the movement, and the distance from the starting position to the target (CRef. 3.309). When the target is located near the front of the subject, accuracy is better when the primary movement is toward the front, and with targets to the side, accuracy is better with movements toward the side. However, when the locus of the movements is disregarded to get an overall view of accuracy, adjustments toward the side are more accurate than adjustments toward the front (CRef. 3.309). Movements away from the body yield smaller percentage errors in placement than movements toward the body (CRef. 3.309).

Position Sense Accuracy with Active Versus Passive Movements

- Location of a target position is perceived more accurately if the subject moves the limb to the target by normal, voluntary muscle contraction (active positioning) than if the experimenter moves the subject's limb (passive positioning) (CRefs. 3.311, 3.312, 3.319). The movement appears to be the important variable; actively maintaining a target position set passively does not improve accuracy, and passively maintaining a target position set actively does not worsen accuracy (CRef. 3.311).
- Speed of the movement to a target position and the length of time a limb remains at the target before its position is estimated can affect perception of target location (CRefs. 3.311, 3.320). With either active or passive movement, the elevation of the target-indicating arm is increasingly underestimated as the arm speed increases and as the delay increases between positioning the reference arm and matching with the indicator arm (CRef. 3.311). The degree of flexion (bending) of the foot changes from overestimation to underestimation as the delay increases between positioning the reference and matching with the indicator foot (CRef. 3.320).

Cross-Modal Effects

- Judgment of target location is more accurate if both target presentation and matching are done within the same modal-

ity (intra-modal matching), whether vision or kinesthesia (CRefs. 5.1010, 5.1016). However, for judgment of target distance (extent of a movement), target presentation in one modality and matching to a perceptually equivalent location in another modality (cross-modal matching) is not less accurate than intramodal matching (CRef. 5.1010).

Influence of Muscle Loading

- Perceived position of a limb can vary with the amount of force exerted by the limb (CRefs. 3.318, 3.320). The degree of bending of the foot is increasingly underestimated as the magnitude of the load increases, irrespective of the direction of the exerted force (CRef. 3.320); however, the absence of a difference dependent on the direction of the force may not always hold true.
- Humans lack an awareness of the true static-positions of the fingers (the interphalangeal joints) (CRef. 3.318), and, under some conditions of loading, perceived position of a finger joint becomes confused with the force exerted by the finger (CRef. 3.318).

Kinesthetic Aftereffects

- A previously held position of a limb produces a shift in the perception of a current position in the direction of the previous position (kinesthetic aftereffect) (CRef. 3.321). For example, if with the eyes closed, one holds an outstretched arm at 11 o'clock for about 10 or 15 sec and then attempts to position the arm to the horizontal, one finds the arm positioned a few degrees above the horizontal. The amount of offset increases with the distance between the previous and the current positions, and the length of time the part is held at the previous position (CRef. 3.310).
- Exerting a torque with a limb may alter the perception of subsequent positions (CRef. 3.310), though not all studies have found this (CRef. 3.308).

Effects of Vibration

- Vibration coupled to a muscle can produce illusions of movement and of altered position of a stationary limb (CRefs. 3.314, 3.315). The limb feels like it is moving and is displaced in a direction that would stretch the vibrated muscle. Vibration strongly excites length/velocity detectors in the muscle, simulating an increase in muscle length that the nervous system interprets as a change in joint angle or limb position (CRef. 3.314).
- The illusions of limb movement and altered limb position are independent and experimentally separable simply by asking the subject to attend either to the movement of the limb or to its position (CRef. 3.314). The movement illusion can be quite vivid and readily noticed; the illusion of altered position is not apparent unless one compares perceived position to actual position (CRef. 3.314). Frequency and mode of application of vibration can selectively enhance movement or positional illusion; tensing muscles diminishes the illusions (CRef. 3.315).

Heaviness and the Sense of Effort

- Apparent heaviness of a weight increases with fatigue or weakness of the muscles that do the lifting (CRef. 3.323). Sense of heaviness derives from an internal monitoring of command signals destined for the muscles (an internal "sense of effort") (CRefs. 3.323, 3.324); larger command signals are needed to lift a weight with weakened muscles and this is interpreted as an increase in heaviness (CRef. 3.323).

3.3 Kinesthesia

- Vibration of muscles can alter apparent heaviness of a weight if vibration sets up reflex contraction of muscles (tonic vibration reflex). If the reflex assists the lifting muscles, the weight appears to be lighter; if it opposes, the weight will appear to be heavier (CRef. 3.325).
- Numbness of the digits can alter perceived heaviness of weights lifted with the index finger or thumb muscles tested (CRef. 3.325). Numbness of either thumb or index finger

increases perceived heaviness (compared to normal) of weights lifted by flexion of either digit and decreases heaviness when lifting is done by extension of the thumb. Electrical stimulation of the normal thumb or index finger, during anesthesia of the opposing digit, will eliminate the increase in perceived heaviness caused by the numbness (CRef. 3.324).

Key References

1. Clark, F. J., & Horch, K. W. (1986). Kinesthesia. In Boff, K. R., Kaufman, L., & Thomas, J. P. (Eds.). (1986). *Handbook of perception and human performance: Vol. 1. Sensory processes and perception*. New York: Wiley.

2. Clark, F. J., Burgess, R. C., Chapin, J. W., & Lipscomb, W. T. (1985). The role of intramuscular receptors in the awareness of limb

position. *Journal of Neurophysiology*, 54, 1529-1540.

3. Goodwin, G. M., McCloskey, D. I., & Matthews, P. B. C. (1972). The contribution of muscle afferents to kinesthesia shown by vibration induced illusions of movement and by the effects of paralyzing joint afferents. *Brain*, 95, 705-748.

4. Hulliger, M. (1984). The mammalian muscle spindle and its central control. *Reviews of Physiology, Biochemistry and Pharmacology*, 101, 1-10.

5. Matthews, P. B. C. (1982). Where does Sherrington's "muscular sense" originate? Muscles, joints, or corollary discharges? *Annual Review of Neuroscience*, 5, 189-218.

6. McCloskey, D. I. (1978). Kinesthetic sensibility. *Physiological Reviews*, 58, 763-820.

7. McCloskey, D. I. (1981). Corollary discharges: Motor commands and perception. In V. B. Brooks (Ed.), *Handbook of physiology, Section 1: The nervous system* (Vol. 2). Bethesda, MD.: American Physiological Society.

Cross References

3.104 Types of cutaneous mechanoreceptors;

3.302 Measurement of position sense;

3.303 Factors affecting sense of position and movement of body parts;

3.304 Passive movement detectability for different joints;

3.305 Detectability of passive movements of finger, elbow, and shoulder joints;

3.306 Detectability of passive rotation of the hip;

3.307 Detectability of finger movement;

3.308 Perception of head position;

3.309 Accuracy of horizontal arm positioning: effect of direction and angular placement;

3.310 Perception of arm position: effect of duration and location of a previously held arm position;

3.311 Perception of arm position: effect of active versus passive movement;

3.312 Perception of arm position: effect of active versus passive movement and practice;

3.313 Position matching of elbow angle and arm orientation;

3.314 Perception of elbow angle;

3.315 Illusory motion of the elbow with muscle vibration;

3.316 Perception of shoulder (arm) position;

3.317 Memory for shoulder (arm) position;

3.318 Perception of finger displacement;

3.319 Perception of knee position;

3.320 Perception of ankle (foot) position;

3.321 Kinesthetic aftereffects;

3.322 Models for the encoding of joint angle;

3.323 Heaviness: effect of arm fatigue;

3.324 Heaviness: effects of anesthesia or electrocutaneous stimulation of the fingers;

3.325 Perception of effort and force: effects of muscle vibration and anesthesia;

5.1010 Cross-modal versus intramodal perception of distance and location;

5.1016 Intermodal and cross-modal spatial pattern recognition

Notes

3.302 Measurement of Position Sense

Key Terms

Active joint movement; joint-movement sense; muscle sense; passive joint movement; position sense; proprioception

General Description

Measurement of position sense (orientation of a limb or digit) involves presentation of a target (reference) position by an experimenter and a response by a subject indicating the perceived position. Visual and other nonkinesthetic cues are eliminated in the presentation and/or response stages. Limb or digit movement to a target location may occur in

unrestricted space or along a track or other tangible guide. Perceived target position may be indicated by moving either the limb used in experiencing the target position or the **contralateral** limb to produce a match. Table 1 describes several alternative methods for presenting the target (or reference) position; Table 2 summarizes various means by which perceived position can be indicated by the subject.

Constraints

• Because measurement of position sense generally involves movement of a limb or digit, it is often difficult to determine if the measurements reflect position sense or movement sense.

• Movement of a limb may cause gross body movements that might alter the orientation of the limb relative to the target and affect the measurement of position sense for that limb.

Key References

*I. Clark, F. J., & Horch, K. W. (1986). Kinesthesia. In K. R. Boff, L. Kaufman, & J. P. Thomas (Eds.), *Handbook of perception and human performance: Vol. 1. Sensory processes and perception*. New York: Wiley.

Cross References

3.303 Factors affecting sense of position and movement of body parts

Table 1. Methods of presenting target (reference) position.

Method	Description	Comments
Passive positioning	Experimenter moves subject's relaxed limb or body part to target position. Often the limb is supported in an apparatus designed for transporting the limb	Variables such as movement, velocity, and direction, can be controlled and quantified when an apparatus is used for limb transport
Active positioning	Subject moves own limb as directed by the experimenter, or until contacting a target stimulus	Movement variables are less easily controlled or quantified when they are voluntary, but subjects can learn to move as instructed by the experimenter
Visual presentation	Target is viewed at its spatial position	It is usually necessary to eliminate from the background extraneous visual cues that might provide a basis for judging location
Verbal presentation	Target position is verbally specified, using a scale of reference with which the subject is familiar	Familiarity with the scale of reference is increased through practice

Table 2. Methods for indicating perceived position.

Method	Description	Comments
Passive positioning	Subject's relaxed limb or body part is passively transported by a supporting carrier mechanism. Subject indicates arrival at target position either verbally or by manipulating carrier controls to terminate movement	Complete relaxation of the muscles is usually difficult to achieve without training
Active positioning	Subject moves own limb by stopping at perceived target location	Movement may be restricted, for example, in an attempt to maintain a particular joint angle or to slide a pointer that moves along a track on which the target position is located
Active pointing	Subject points index finger to perceived target location	
Visual indication	Scale corresponding to spatial positions or display of target alternatives is visually presented. Using the scale or display as a reference, subject indicates perceived target position. Alternatively, subject may manipulate a control to vary position of visual target	
Verbal indication	Subject verbally specifies perceived target position using a scale of reference	Scale of reference may be familiar or adapted for use in experiment

3.303 Factors Affecting Sense of Position and Movement of Body Parts

Key Terms

Active limb movement; joint position; joint-movement sense; kinesthetic aftereffects; limb movement; limb position; limb-movement detection; limb-movement velocity;

limb-positioning accuracy; memory for limb position; muscle contraction; muscle fatigue; muscle loading; muscle sense; muscle vibration; passive limb movement; position sense; skin anesthesia

General Description

Perception of the position and movement of the limbs and other body parts relies on information from specialized sensory receptors regarding joint angle, and muscle and tendon tension. The table summarizes factors that affect the sense of body position and movement.

Constraints

- Interactions may occur among these factors, but such interactions have not generally been studied.

Key References

1. Clark, F. J., & Horch, K. W. (1986). Kinesthesia. In K. R. Boff, L. Kaufman, & J. P. Thomas

(Eds.), *Handbook of perception and human performance: Vol. 1. Sensory processes and perception*. New York: Wiley.

Cross References

3.302 Measurement of position sense;
 3.304 Passive movement detectability for different joints;
 3.305 Detectability of passive movements of finger, elbow, and shoulder joints;
 3.307 Detectability of finger movement;
 3.308 Perception of head position;
 3.309 Accuracy of horizontal arm positioning: effect of direction and angular placement;

3.310 Perception of arm position: effect of duration and location of a previously held arm position;
 3.311 Perception of arm position: effect of active versus passive movement;
 3.312 Perception of arm position: effect of active versus passive movement and practice;
 3.314 Perception of elbow angle;
 3.315 Illusory motion of the elbow with muscle vibration;
 3.316 Perception of shoulder (arm) position;
 3.317 Memory for shoulder (arm) position;

3.318 Perception of finger displacement;
 3.319 Perception of knee position;
 3.320 Perception of ankle (foot) position;
 3.321 Kinesthetic aftereffects;
 3.323 Heaviness: effect of arm fatigue;
 3.324 Heaviness: effects of anesthesia or electrocutaneous stimulation of the fingers;
 3.325 Perception of effort and force: effects of muscle vibration and anesthesia;
 5.1007 Spatial localization in the presence of intersensory conflict;

5.1008 Spatial localization in the presence of visual-proprioceptive conflict: effect of amount of intersensory discrepancy;
 5.1010 Cross-modal versus intramodal perception of distance and location;
 5.1016 Intermodal and cross-modal spatial pattern recognition;
 5.1101 Adaptation of space perception;
 5.1112 Effects of adaptation to prismatic displacement of the visual field;
 9.204 Blind positioning: effects of prior target exposure

Factor	Effect on Sense of Position and Movement	References
Limb or joint position	Accuracy in estimating the position of a limb or joint varies with position Accuracy decreases toward extreme positions of a joint, with errors directed toward mid-positions of the joint (e.g., 90° for the elbow, arm horizontal for the shoulder)	CRefs. 3.309, 3.316 CRef. 3.304
Limb or joint moved	Sensitivity to movement is greater for joints closer to the trunk (proximal joints) than for joints further away from the torso (distal)	
Sensory modality used in presenting and estimating limb or joint position	Accuracy in reproducing a target limb or joint described verbally is much poorer than accuracy in matching limb to a position experienced earlier For <i>active</i> positioning <i>movement</i> , position is judged more accurately when the same modality (vision or kinesthesia) is used to present the target position and to indicate perceived location (intramodal matching) than when one modality is used to establish the target position and another modality is used to judge perceived location (cross-modal matching); cross-modal judgments are superior for passive movement Visual pattern recognition is better for patterns presented visually than for patterns presented kinesthetically (by tracing)	CRefs. 5.1010, 5.1016

Factor	Effect on Sense of Position and Movement	References
Passive versus active movement	Position judgments based on active movement are more accurate than those based on passive movement Cross-modal position judgments are more accurate for passive movement	CRefs. 3.311, 3.312, 3.319, 5.1010
Distance of movement	In making positioning movements to a given target location, short distances are overestimated and long distances underestimated Relative error decreases and variability increases with increasing distance of positioning movement	CRef. 9.204 CRef. 3.309
Direction of movement	Positioning movements to the side of the body are more accurate than movements to the front of the body Movements toward an extreme position (straight ahead or straight out to the side) are more accurate than movements away from an extreme position	
Muscle contraction (flexion/extension)	Error is greatest and variability least for matching joint angles at extreme flexion or extension Movements of a joint are easier to detect if the muscles that move the joint are contracted slightly rather than relaxed	CRefs. 3.314, 3.324
Velocity of movement	Detectability of movement increases with increasing movement velocity. As the velocity of arm positioning movements increases, arm elevation becomes increasingly underestimated	CRefs. 3.305, 3.307, 3.311
Delay between presenting and judging limb or joint position (matching from memory)	Accuracy in estimating shoulder position is reduced and variability is increased with increasing delays, but only to a small to moderate extent even over a 24-hour interval Increasing delay changes judgment of foot flexion or arm position from overestimation to underestimation	CRefs. 3.311, 3.317, 3.320
Duration of holding position (aftereffects)	The longer a starting position is held, the more position is overestimated when the arm is moved a short distance to a second location, but not when the arm is moved a long distance Perceived head or arm position is shifted in the direction of a previously held position	CRefs. 3.308, 3.310, 3.321
Vibration	Application of vibration to muscle of a limb produces the illusion of limb movement and of altered limb position Application of vibration causes reflex muscle contraction Vibration increases error in estimating an exerted force and in matching an applied force	CRefs. 3.314, 3.315
Load on muscle	Load affects judgment of foot flexion Judged position is in the direction of an isometric force exerted against an imposed load	CRefs. 3.318, 3.320
Muscle fatigue	Judged heaviness increases with increasing muscle fatigue	CRef. 3.323
Anesthesia	Anesthesia of the skin of the thumb alters perceived heaviness when judging weights lifted with the thumb. Weights lifted by flexion of the thumb are perceived as heavier, and those lifted by extension of the thumb as lighter There is no alteration by anesthesia when weights are lifted by the elbow using the muscles of the thumb only to maintain the thumb in a fixed position Anesthesia of the skin of the fingers increases error in estimating exerted force or matching an applied force using the finger muscles	CRefs. 3.324, 3.325
Electrical stimulation	Electrical stimulation of the index finger decreases perceived heaviness of a weight lifted by the thumb; stimulation of the thumb decreases perceived heaviness of a weight lifted by the index finger	CRef. 3.324
Distortion of the visual scene	Prolonged exposure to visual distortion (such as produced by wedge prisms and other optical devices) can lead to changes in the felt position of body parts	CRefs. 5.1101, 5.1112
Discrepancy between visual and kinesthetic senses	Under special conditions where visual information about the environment contradicts information from the position or joint-movement sense (kinesthesia), the felt position of body parts may be altered	CRefs. 5.1007, 5.1008

3.304 Passive Movement Detectability for Different Joints

Key Terms

Ankle rotation; arm movement; elbow movement; elbow rotation; finger joint; finger movement; foot movement; hand movement; hip joint; hip rotation; joint-movement de-

tection; joint-movement sense; joint-movement velocity; knee joint; knee rotation; leg movement; passive joint movement; shoulder joint; shoulder rotation; toe movement; wrist joint; wrist rotation

General Description

The smallest passive (externally imposed) movement of a joint which subjects can detect varies for different joints of the body. Table 1 compares detectability for forelimb and leg joints as a function of the subject's age. Tables 2 and 3

compare movement detectability measurements for the elbow joint and for several other joints, respectively, obtained by studies using different criteria of detectability, different methods of moving the joint, and different rates of joint movement.

Methods

Test Conditions

- Data in Table 1 based on passive movements of 10 deg/min
- Studies in Table 2 used velocities of 0.08-1.4 deg/sec for movement of elbow joint

- Velocities of 0.15-5.0 deg/sec used to passively move joints tested in the studies in Table 3
- No visual feedback was present

Experimental Procedure

- Method of constant stimuli (Table 1); various methods for

studies cited in Tables 2 and 3 (see footnotes to table)

- Independent variables: age (Table 1), joint moved, velocity of movement
- Dependent variable: detectability of joint movement

- Subject's task: indicate whether joint moved; specifying direction of movement required in some studies
- For Table 1, 40 subjects, 17-35 yr, and 20 subjects, 50-85 yr

Experimental Results

- Detectability of joint movement varies with the joint moved, the method used to move the joint, and the method of defining detectability.
- Proximal joints (those closest to the torso) appear to be more sensitive to movement than distal joints (those farther away from torso).

Variability

Detectability on the two sides of the body is essentially the same. Older age group (Table 1) made a higher percentage of errors in judging the direction of passive movement than did younger age group. Errors were related to training and capacity for detailed observation.

Constraints

- Detectability of joint movement depends on both the speed and the amplitude of the excursion (CRef. 3.305).

Table 1. Minimum joint displacement detected by subjects of two age groups. (From Ref. 7)

Joint	Modal Threshold Displacement (deg)			
	Under 40 yrs of age		Over 50 yrs of age	
	Up	Down	Up	Down
Shoulder	0.4	0.3	0.5	0.5
Elbow	0.4	0.4	0.5	0.7
Wrist	0.3	0.5	0.5	0.5
First MCP	0.5	0.6	0.5	0.5
Second MCP	0.5	0.5	0.5	0.5
Third MCP	0.4	0.4	0.6	0.5
Fourth MCP	0.4	0.5	0.6	0.6
Fifth MCP	0.5	0.7	0.5	0.5
Hip	0.2	0.2	0.4	0.5
Knee	0.3	0.3	0.5	0.6
Ankle	0.3	0.3	0.5	0.6
First MTP	0.7	0.7		not done

MCP = metacarpophalangeal (finger joint)
 MTP = metatarsophalangeal (toe joint)

Table 2. Smallest detectable angular movement of elbow joint: comparison of results from different investigations. (From Ref. 3)

References	Number of Subjects	Range of Speeds (deg/sec)	Range of Thresholds (deg)
Ref. 4	1	0.7-1.4	0.40-0.76 ^a
Ref. 8	3	0.33	0.43-0.85 ^b
Ref. 10	7	0.08-0.56	0.20-2.80 ^b
Ref. 7	60	0.16	0.30-2.50 ^b
Ref. 3	4	0.10-0.25	0.80-1.80 ^c

^aThreshold defined as value "just perceived" for at least half the trials

^bThreshold defined as average value of displacement where subjects perceived movement

^cThreshold defined as displacement value for which direction of movement identified correctly on 80% of trials

Key References

- Browne, K., Lee, J., & Ring, P. A. (1954). The sensation of passive movement at the metatarsophalangeal joint of the great toe in man. *Journal of Physiology*, 126, 448-458.
- Clark, F. J., & Horch, K. W. (1986). Kinesthesia. In K. R. Boff, L. Kaufman, & J. P. Thomas (Eds.), *Handbook of perception and human performance: Vol. 1. Sensory processes and perception*. New York: Wiley.
- Cleghorn, T. E., & Darcus, H. D. (1952). The sensibility to passive movement of the human elbow joint. *Quarterly Journal of Experimental Psychology*, 4, 66-77.
- Goldscheider, A. (1889). Untersuchungen über den Muskelsinn. *Archiv für Anatomie und Physiologie*, 3, 369-502.
- Grigg, P., Finerman, G. A., & Riley, L. H. (1973). Joint-position sense after total hip replacement. *Journal of Bone and Joint Surgery*, 1016-1025.
- Kokmen, E., Bossemeyer, R. W., & Williams, W. J. (1977). Quantitation of motion perception in the digits: A psychophysical study of normal human subjects. *Annals of Neurology*, 2, 279-284.
- Laidlaw, R. W., & Hamilton, M. A. (1937). A study of thresholds in apperception of passive movement among normal control subjects. *Bulletin of the Neurological Institute of New York*, 6, 268-273.
- Pillsbury, W. B. (1901). Does the sensation of movement originate in the muscle? *American Journal of Psychology*, 12, 346-353.
- Provins, K. A. (1958). The effect of peripheral nerve block on the appreciation and execution of finger movements. *Journal of Physiology*, 143, 55-67.
- Winter, J. E. (1912). The sensation of movement. *Psychological Review*, 19, 374-385.

Cross References

- 3.306 Detectability of passive rotation of the hip;
Handbook of perception and human performance, Ch. 13, Sect. 2.1
- 3.305 Detectability of passive movements of finger, elbow, and shoulder joints;

Table 3. Smallest detectable angular movement of several joints. (From Ref. 2)

Joint	Number of Subjects	Velocity (deg/sec)	Average Threshold (deg)
Hip (Ref. 5)	2	0.15	0.22 ^a
	7	0.6	6.66 ^b
Second MCP (Ref. 9)	12	0.63	6.10 ^{b,c}
			5.47 ^{b,d}
			4.20 ^{b,e}
Second and fifth MCP and first MTP (Ref. 6)	14	0.5 ^f	0.8-1.0
		5.0	0.4-0.6
First MTP (Ref. 1)	82	1 & 2	4.4 ^b

^aMethod of constant stimuli (constant amplitude displacement)

^bJoint moved passively at constant rate; subjects indicated when they experienced definite sensation of movement

^cFinger relaxed

^dWith voluntary flexion (20-50 g force)

^eWith voluntary extension (20-50 g force)

^fSinusoidal rotation of joint with slowly increasing amplitude until subject perceived movement, then amplitude decreased until sensation disappeared; threshold defined as amplitude halfway between these two values.

MCP = metacarpophalangeal (finger joint)

MTP = metatarsophalangeal (toe joint)

3.305 Detectability of Passive Movements of Finger, Elbow, and Shoulder Joints

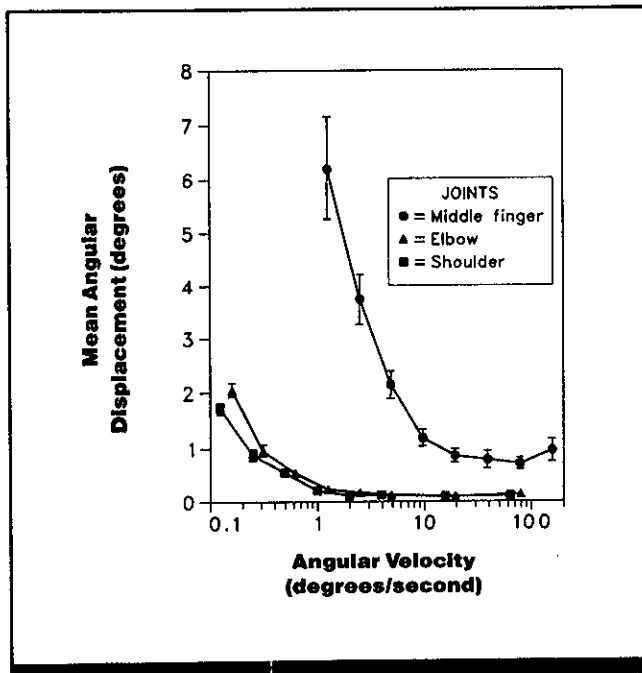

Figure 1. Mean amplitude of displacement necessary for 70% correct identification of direction of passive movement of joints. Movements were randomly mixed flexions and extensions, with angular velocities as shown by the x-axis. (From Ref. 2)

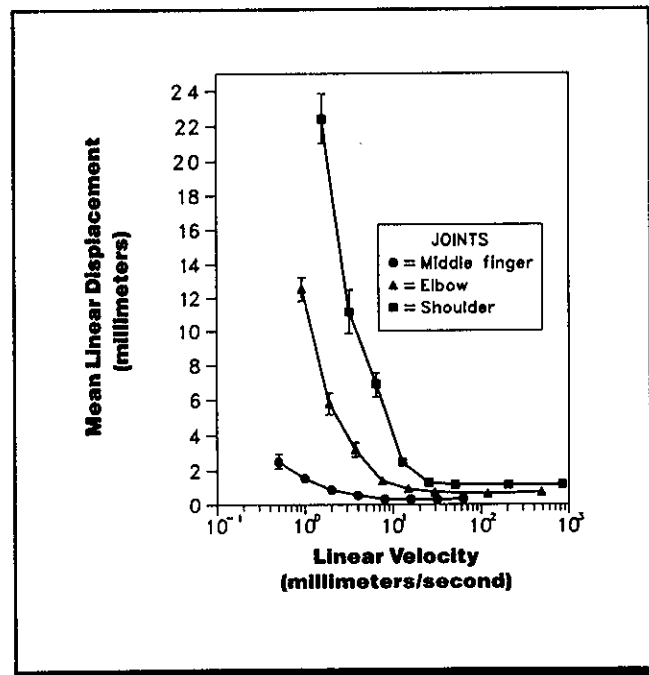

Figure 2. Data from Fig. 1 converted to the linear displacements and velocities (log scale) occurring at the fingertip as each of the test joints is rotated. (From Ref. 2)

Key Terms

Arm movement; elbow movement; elbow rotation; finger joint; finger movement; joint-movement detection; joint-movement velocity; limb-movement detection; passive joint movement; shoulder joint; shoulder rotation

General Description

The ability to detect passive (imposed) excursions of a joint increases with both the amplitude of the excursion and angular velocity. An excursion too small for reliable detection at a particular velocity may become easily detected at a higher velocity. When expressed in terms of *angular* displacement and angular velocity, detection performance at

the elbow and shoulder is superior to performance at the finger (Fig. 1). However, when assessed in terms of *linear* displacement and linear velocity of the fingertip, the order of performance abilities is reversed (Fig. 2). Detection performance is similar for elbow and finger joints when measured as a function of the proportional changes in the length of the muscles operating these joints (Fig. 3).

Methods

Test Conditions

- Forearm positioned in apparatus that passively moved joint to be tested; movement was shielded from subject's view
- Terminal joint of middle finger

moved at 1.25-160 deg/sec, elbow joint at 0.156-80 deg/sec, and shoulder joint at 0.125-64 deg/sec

- Movements executed in 0.25-1.0-deg increments for finger, 0.1-1.0-deg increments for elbow and shoulder
- Ten flexions and ten extensions for each condition

Experimental Procedure

- Method of constant stimuli
- Independent variables: velocity of movement, measured as angular movement at joint (angular velocity), linear movement at fingertip (linear velocity), and velocity of

proportional change in length of joint muscles

- Dependent variable: displacement required for 70% correct detection of direction of movement
- Subject's task: indicate perceived direction of movement
- 10 subjects

Experimental Results

- Detectability of angular rotation imposed upon the elbow, shoulder, or finger joint increases with an increase in the velocity of movement.
- When detectability is measured in terms of the angular movement of the joint (Fig. 1), the elbow and shoulder are superior to the finger (paired t test, $p < 0.001$). However, this pattern reverses when detectability is measured in terms of linear displacement of the fingertip (Fig. 2).
- Detectability of proportional changes in the length of joint muscles is similar at the elbow and finger (Fig. 3).

Variability

Bars in Figs. 1 and 2 represent standard errors of the means, based on a random set of ten flexions and ten extensions. Frequency of false positions (movement detected, direction incorrect) was $< 5\%$.

Repeatability/Comparison with Other Studies

The results are consistent with the widely cited findings of Goldscheider (Ref. 1), where proprioceptive acuity, expressed as angular rotation needed for detection, is greater at more proximal joints (joints closer to the torso).

Constraints

- Detectability of active movement is likely to be different from the detectability reported here for passive movement of the joints.
- Movement per se can be detected before the direction of movement is known.

Key References

1. Goldscheider, A. (1889). Untersuchungen über den Muskelsinn (Examination of the muscle sense). *Archiv für Anatomie und Physiologie*, 3, 369-502.

*2. Hall, L. A., & McCloskey, D. I. (1983). Detections of movements imposed on finger, elbow and shoulder joints. *Journal of Physiology*, 335, 519-533.

Cross References

3.304 Passive movement detectability for different joints;

3.307 Detectability of finger movement;

Handbook of perception and human performance, Ch. 13, Sect. 2.1

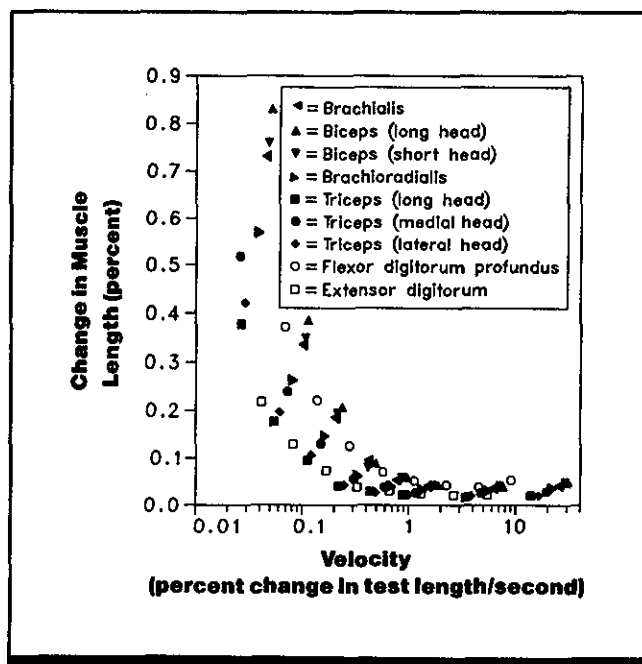

Figure 3. Data for the elbow and finger joints in Fig. 1 converted to percentage changes in the lengths of fascicles in individual muscles. Conversion of data was done by measuring the median length of individual muscle fascicles in each muscle and the alteration in those lengths per degree of angular rotation. Data are given as the percentage change of test length of fascicles as a function of the velocity of such changes (log scale). (From Ref. 2)

3.306 Detectability of Passive Rotation of the Hip

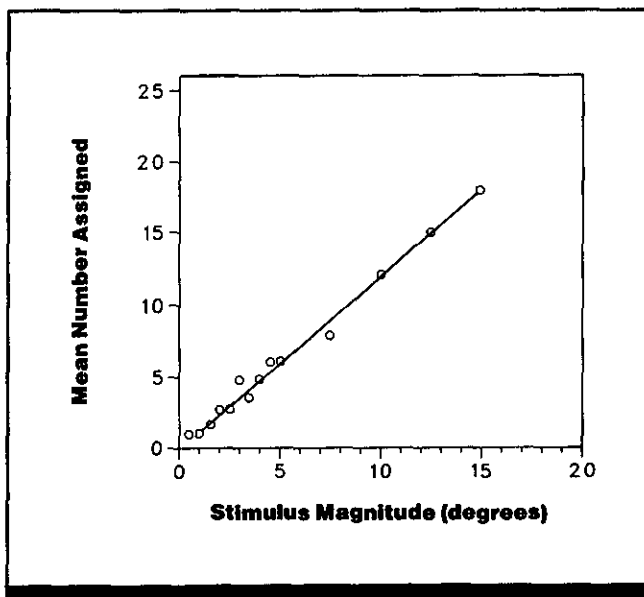

Figure 1. Perceived magnitude of hip movement as a function of actual rotation amplitude. Results are for a patient who had one normal hip and one hip which had undergone surgery. Data presented for normal hip only. Subject assigned a value to each rotation amplitude based on its apparent magnitude in relation to a reference rotation of 7.5 deg which was assigned the value "15" (Ref. 1).

Key Terms

Hip joint; hip rotation; joint-movement detection; joint-movement sense; kinesthetic sensation magnitude; leg movement; limb-movement detection; passive joint movement

General Description

The smallest detectable passive (externally imposed) rotation of the hip is 0.66 deg. Estimates of the amplitude of hip movement correlate highly with the objective amplitude of movement.

Methods

Test Conditions

- Subjects lay in supine position while hip joint was passively rotated by mechanical movable arm
- For detection thresholds, rotations at a rate of 0.6 deg/sec were terminated by subject's use of a cut-off switch at moment of detection
- For estimations of movement magnitude, 7.5-deg rotation was

assigned the number 15 and subjects used this reference to judge rotations of 0.5-5 deg in 0.5 deg steps and 5-15 deg in 2.5 deg steps

- No visual or auditory feedback was present

Experimental Procedure

- Method of adjustment for threshold determinations; method of magnitude estimation for magnitude judgments

- Independent variable: amplitude of hip joint rotation (in degrees)
- Dependent variables: threshold, defined as just-detectable rotation in degrees; perceived magnitude of rotation measured in terms of numbers assigned to rotations based on a reference rotation of 7.5 deg = number 15
- Subject's task: employ cut-off switch to terminate rotation at point of detection; assign numbers to ro-

tations to estimate extent of rotation

- Ten measurements per threshold
- Thresholds based on data from 10 subjects; magnitude estimations based on 1 subject; all subjects were patients who had undergone unilateral total hip replacements 2 weeks prior to testing (data presented here for normal hip only; no further description of subjects was given)

Experimental Results

- Mean threshold for detection of passive movement of the hip joint at displacements of 0.6 deg/sec is 0.66 deg.
- Subjects' estimates of the magnitude of hip joint excursion correlate highly with the objective magnitude of movement ($r = 0.844$).

Variability

No specific information on variability of threshold judgments or magnitude estimates was given. Data were obtained mainly to compare hip joint movement sense in normal and operated hip of subjects who had undergone total hip replacement.

Key References

*1. Grigg, P., Finerman, G. A., & Riley, L. H. (1973). Joint-position sense after total hip replacement. *Journal of Bone and Joint Surgery*, 55 A, 1016-1025.

Cross References

3.304 Passive movement detectability for different joints;

Handbook of perception and human performance, Ch. 13, Sect. 4.3

3.307 Detectability of Finger Movement

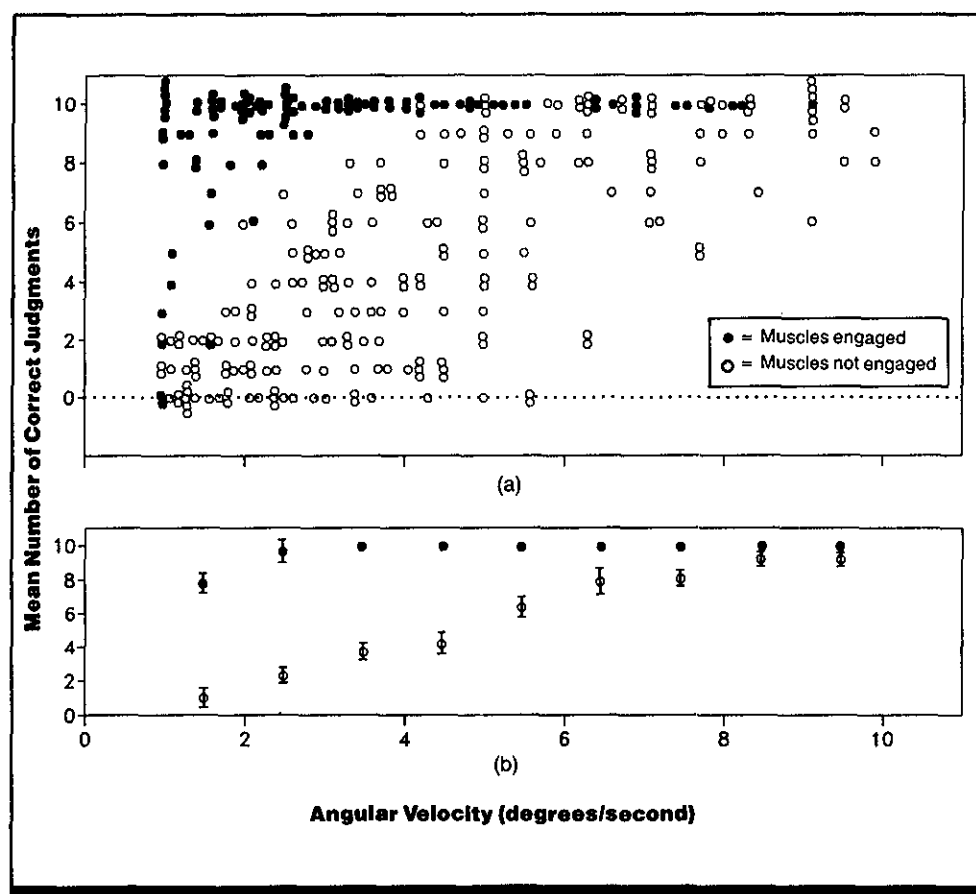

Figure 1. Mean number of correct judgments of direction of movement of 10-deg displacements at various angular velocities. No distinction is made between scores obtained for movements into flexion and movements into extension. (a) Data from 12 subjects plotted together; (b) data grouped into velocity ranges (1.0 - 1.9 deg/sec, 2.0 - 2.9 deg/sec, etc.), averaged for all subjects and plotted as mean number of correct judgments (± 1 standard error) in ten trials at each point. (From Ref. 3)

Key Terms

Finger joint; finger movement; joint-movement detection; joint-movement sense; joint-movement velocity; muscle sense

General Description

Detectability of finger movement increases with increasing angular velocity and/or increasing amplitude of the excursion. The ability to detect movement of the finger is greatly impaired if the contribution of muscle sense is eliminated and only skin and joint mechanisms are able to signal finger movement.

Methods

Test Conditions

- Fingers were positioned so that the muscles that move the distal interphalangeal (terminal) joint of middle finger were either engaged

or disengaged (i.e., muscles either able or unable to move joint)

- Terminal joint of middle finger mechanically flexed or extended 10 deg for 1.2 sec at 1-10 deg/sec in 1-deg steps
- No visual feedback

Experimental Procedure

- Method of constant stimuli
- Independent variables: presence or absence of muscle tension on terminal joint of middle finger, angular velocity of movement
- Dependent variable: detectability of movement (in number of correct

judgments of movement and direction)

- Subject's task: indicate whether finger joint was moved and in what direction
- Ten trials per flexion; ten trials per extension for each condition
- 12 subjects

Experimental Results

- Detectability of finger displacement with the muscle sense engaged is superior to detectability in the absence of the muscle sense.
- Detectability of finger displacement increases with increasing angular velocity of displacement and with increasing amplitude of displacement.

Key References

1. Clark, F. J., Burgess, R. C., & Chapin, J. W. (1983). Humans lack of sense of static-position of the fingers. *Society for Neuroscience Abstracts*, 9, 1033.

2. Gandevia, S. C., Hall, L. A., McCloskey, D. I., & Potter, E. K. (1983). Proprioceptive sensation at the terminal joint of the middle finger. *Journal of Physiology*, 335, 507-517.

*3. Gandevia, S. C., & McCloskey, D. I. (1976). Joint sense, muscle sense, and their combination as position sense, measured at the distal interphalangeal joint of the middle finger. *Journal of Physiology*, 260, 387-407.

Cross References

3.318 Perception of finger displacement;

Handbook of perception and human performance, Ch. 13, Sect. 4.2

Variability

Error bars showing ± 1 standard error of the mean are based on the means of 20 judgments (flexion and extension combined).

Repeatability/Comparison with Other Studies

Similar results have been found in other studies (Refs. 1, 2).

3.308 Perception of Head Position

Key Terms

Head position; kinesthetic adaptation; kinesthetic after-effects; position sense; postural persistence

General Description

If the head is rotated to one side for a fixed period, an attempt to restore the head to its normal (straight ahead) position results in a bias in head position in the direction of the prior rotation. This effect does not occur if the head is kept straight ahead while straining against a force that tries to rotate it to the side.

Methods

Test Conditions

- 10-min adaptation periods consisted of keeping the head at a fixed rotation of 24 deg to the right or maintaining a straight-ahead position while straining against a 94-g force to the left

- Test conditions involved returning the head to perceived straight-ahead position from any of six starting positions (12, 24, and 36 deg to right and left of center), or moving pointer with index fingers to position directly in front of the nose for head rotations of 0 or 24 deg to left or right

- Subject sat in darkness during all tests

Experimental Procedure

- Method of adjustment
- Independent variable: head rotation condition (rotated, not rotated, or opposing a force)
- Dependent variables: shift in

perceived head position, measured as the difference between position of head or hands when set to perceived straight ahead before and after adaptation to head rotation

- Subject's task: position head to normal straight ahead position or point to location directly ahead of the nose
- 12 subjects

Experimental Results

- After the head is held rotated to one side for a period of time, the perceived position of the head is shifted in the direction of the previously maintained head rotation. This effect is reduced if the head is rotated in a direction opposite that during adaptation just prior to testing.
- The perceived position of the head is not affected by straining against a force to one side.

Variability

Ninety-five percent confidence limits are given in the table.

Repeatability/Comparison with Other Studies

Similar results have been found for arm position (Ref. 2). Reference 3 found that arm muscle strain likewise had no effect on pointing accuracy.

Constraints

- Shift in perceived head position following prolonged head rotation will be manifested only if subject is tested in the absence of vision (blindfolded or in the dark).

Table 1. Mean error in judging position of head after adaption to head rotation. (From Ref. 4)

Adaptation Condition	Test			
	Head to Straight Ahead	Fingers to Head at		
		+24 deg	0 deg	-24 deg
Head rotated 24 deg to right	+5.9 ± 1.3*	-6.2 ± 1.6*	-6.8 ± 1.6*	-3.4 ± 1.0*
Head held straight ahead, strained to left	+0.9 ± 2.1	-0.4 ± 1.2	-1.0 ± 1.5	-0.3 ± 1.7
Head held straight ahead, relaxed (control condition)	-0.01 ± 1.1	+0.8 ± 0.8	+0.4 ± 1.1	-0.5 ± 1.8

* Significant at $p < 0.001$ (two-tailed t test).

Note: Values represent differences (in degrees) between means judged position (\pm 95% confidence intervals) before and after prolonged head rotation to right; positive values indicate shifts to the right.

Key References

1. Clark, F. J., & Horch, K. W. (1986). Kinesthesia. In K. R. Boff, L. Kaufman, & J. P. Thomas (Eds.), *Handbook of perception and human performance: Vol. I.*

Sensory processes and perception. New York: Wiley.

2. Craske, B., & Crawshaw, M. (1974). Differential errors of kinesis produced by previous limb position. *Journal of Motor Behavior, 6*, 273-278.

3. Heide, J., & Molbech, S. (1973). Influence of after-movement on muscle memory following isometric muscle contraction. *Ergonomics, 16*, 787-796.

*4. Howard, I. P., & Anstis, T. (1974). Muscular and joint-receptor components in postural persistence. *Journal of Experimental Psychology, 103*, 167-170.

Cross References

3.302 Measurement of position sense;

3.310 Perception arm position: ef-

fect of duration and location of a previously held arm position;

Handbook of perception and human performance, Ch. 13, Sect. 2.2

3.309 Accuracy of Horizontal Arm Positioning: Effect of Direction and Angular Placement

Key Terms

Arm position; arm-positioning accuracy; direction of limb movement; position sense; shoulder joint; shoulder rotation

General Description

When subjects must move the outstretched arm in a horizontal plane to a location 10 deg from a starting point, positioning accuracy is greater for movements toward the side than toward the front. Placement is more accurate when the arm is moved toward, rather than away from, an extreme position (straight ahead or straight out to the side).

Methods

Test Conditions

- Right arm maintained at shoulder height and moved horizontally into starting positions between 0 deg (straight ahead) and 90 deg (straight out to the right); ten starting positions varied in 10-deg increments
- Subject was told angular position of starting point (in degrees) and was then required to move arm to a position subjectively 10 deg greater or less than starting point
- No visual feedback was present

- Independent variables: angular position of starting point; direction of required movement
- Dependent variables: positioning accuracy, measured in terms of constant error (degrees) and standard deviation of mean error; subject was informed of accuracy of judgments after each trial
- Subject's task: move arm into a position either 10 deg greater or less than the angular position of the starting point
- 20 trials per starting point; 20 practice trials and 20 test trials per day for 20 days
- 12 subjects

Experimental Procedure

- Method of adjustment

Experimental Results

- The outstretched arm can be more accurately placed at horizontal target positions requiring movements toward the side of the body than toward the front.
- Accuracy in making a 10-deg arm movement is greater when the arm is moved toward an extreme position (directly ahead or straight out to the side) rather than away from an extreme position.

Variability

Practice resulted in less variability, but did not affect the direction of movement or mean extent of errors. Standard deviations of positioning error are shown in Fig. 1b.

Repeatability/Comparison with Other Studies

Similar results have been reported in Ref. 1, which also showed that movements away from the body result in smaller percentage errors in placement than movements toward the body.

Constraints

- The results might better be interpreted as reflecting the ability to produce a constant 10-deg displacement from different starting points than the ability to locate particular angular positions.

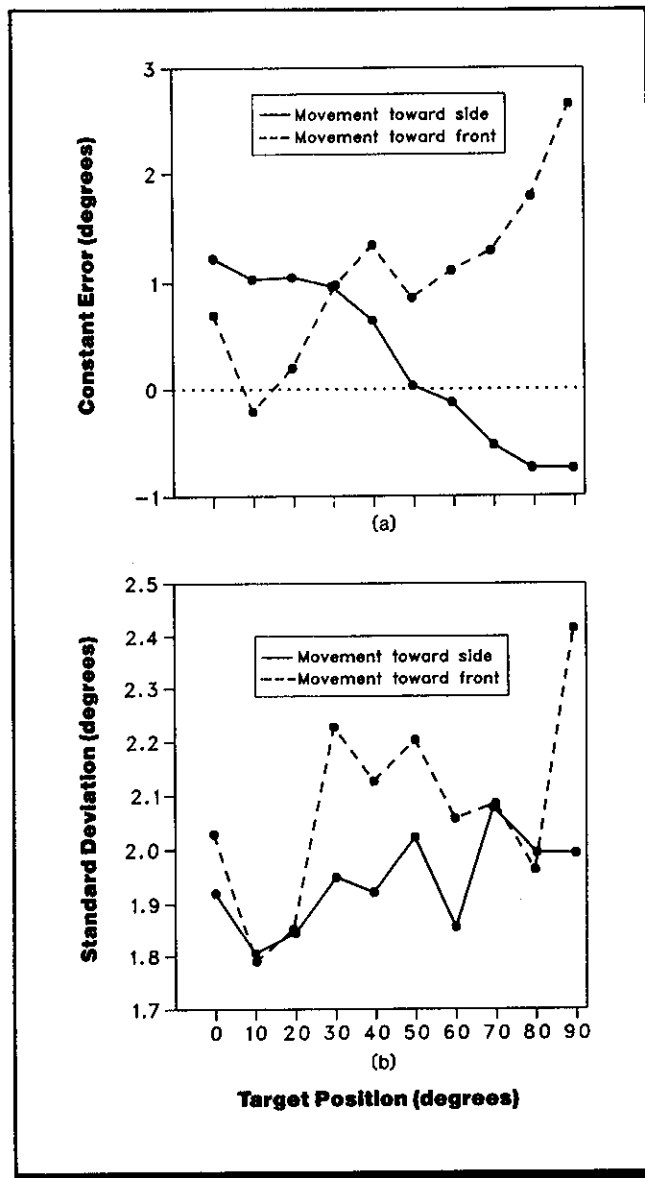

Figure 1. Accuracy of judging 10-deg arm movement as a function of final target position and direction of movement measured as (a) constant error and (b) standard deviation. Straight ahead = 0 deg, straight out to right side = 90 deg. Target position is the position to which arm was to arrive after 10 deg movement. Constant error is the average amount by which the arm movement exceeded (positive values) or fell below (negative values) the target value of 10 deg. Standard deviation indicates the dispersion of the errors about the mean error. (From *Handbook of perception and human performance*, based on data from Ref. 2)

Key References

1. Brown, J. S., Knauff, E. B., & Rosenbaum, G. (1948). The accuracy of positioning reactions as a function of their direction and ex-

tent. *American Journal of Psychology*, 61, 167-182.

*2. Caldwell, L. S. (1956). *The accuracy of constant angular displacement of the arm in the*

horizontal plane as influenced by the direction and locus of the primary adjustive movement (Rep. No. 233, pp. 1-16). Fort Knox, KY: Army Medical Research Laboratory.

Cross References

3.310 Perception of arm position: effect of duration and location of a previously held arm position;

3.316 Perception of shoulder (arm) position;

9.204 Blinder positioning: effects of prior target exposure;

Handbook of perception and human performance, Ch. 13, Sect. 2.2

3.310 Perception of Arm Position: Effect of Duration and Location of a Previously Held Arm Position

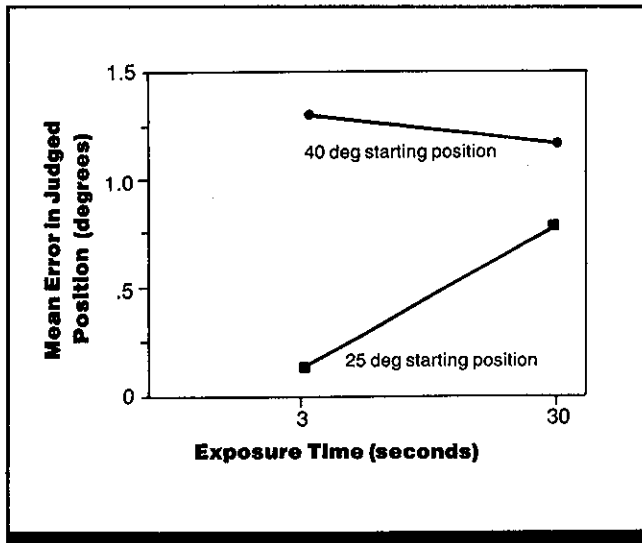

Figure 1. Mean error in judged position of the arm as a function of exposure duration for starting positions of 25 and 40 deg to right of midline (1 deg equals ~12.25 mm at arm's length). (Adapted from Ref. 2)

Key Terms

Arm position; kinesthetic adaptation; kinesthetic after-effects; position sense; shoulder joint; shoulder rotation

General Description

When the arm is held motionless in one position for several seconds, then moved to a second position in the horizontal plane, the arm feels farther away from the starting position than it actually is. The aftereffect (error) increases as the

distance between the first and second positions increases. At short distances, the effect also increases with the time the arm is held in the starting position.

Errors are slightly less with active positioning (self-movements) than with passive positioning of the arm.

Methods

Test Conditions

- Right arm horizontally positioned in a wheeled cradle
- Subject (with eyes closed) moved arm from the midline dividing body into right and left halves to a starting position 25 or 40 deg to the right

- Arm held in starting position for 3 or 30 sec before moving left to one of ten test positions centered about midline and separated by 1 deg
- After 1-sec pause at this position, subject opened eyes to read scale to estimate kinesthetically perceived arm position (arm hidden from view)

Experimental Procedure

- Independent variables: radial distance between starting and test positions, duration for which starting position held
- Dependent variable: judged location of arm
- Subject's task: indicate position of (unseen) arm by estimating loca-

- tion in reference to values on a visible scale
- Ten judgments per starting position (25 and 40 deg) per exposure time (3 and 30 sec)
- Each subject performed all tasks (40) once; order of presentation was randomized
- 16 subjects, trained to move arm ~5.7 deg/sec

Experimental Results

- When the right arm is held for several seconds in a horizontal position either 40 or 25 deg to the right of the midline (median plane) of the body, then moved to a second position closer to the midline, the arm is judged to be farther from the starting position than it actually is (when tested with eyes closed).

- Error of position judgments is greater for a starting position 40 deg from the midline than for a starting position 25 deg away ($p < 0.001$).
- The duration for which the arm is held at the starting position has no effect on error when the initial position is 40 deg from the midline; error is greatly increased for longer duration with a 25-deg starting position.

Variability

Errors are means of ten judgments made at the ten test positions. A three-way analysis of variance was performed on the 64 means (4 conditions \times 16 subjects) to determine significance.

Repeatability/Comparison with Other Studies

These results are comparable to those of other studies reporting kinesthetic aftereffects (CRef. 3.321). Such after-

effects alter perceived location of the limb or apparent heaviness of body part, and are a consequence of maintaining a limb or body part in a fixed position for some period.

When a target position of an arm is reproduced after being held against an external force, the arm feels displaced from the target position in a direction opposite that of the force exerted by the subject to maintain arm position; this alteration in perceived position may conflict with other findings (CRef. 3.308).

Key References

1. Collins, J. K. (1971). Isolation of the muscular component in a proprioceptive spatial aftereffect. *Journal of Experimental Psychology*, 90, 287-299.

*2. Craske, B., & Crawshaw, M. (1974). Differential errors of kinesis produced by previous limb position. *Journal of Motor Behavior*, 6, 273-278.

3. Craske, B., & Crawshaw, M. (1975). Shifts in kinesis through time and after active and passive movements. *Perceptual and Motor Skills*, 40, 755-761.

Cross References

3.302 Measurement of position dense;

3.308 Perception of head position;

3.321 Kinesthetic aftereffects;

Handbook of perception and human performance, Ch. 13, Sect. 2.2

3.311 Perception of Arm Position: Effect of Active Versus Passive Movement

Key Terms

Active limb movement; arm position; limb-movement velocity; passive limb movement; position sense; shoulder joint; shoulder rotation

General Description

Judgments of arm elevation, as indicated by the ability to match the vertical position of one hand to the apparent vertical position of the other (with eyes closed) is more accurate when the reference arm is moved by the subject's own muscle activity (active movement) than when the limb is positioned by an experimenter (passive movement). With either active or passive movement, the elevation of the arm is increasingly underestimated as the delay between elevating the arm and indicating its perceived position increases.

Methods

Test Conditions

- Index fingers held sliders that moved along two parallel vertical tracks
- One hand moved to target position either by subject (active movement) or by experimenter's manipulation of a cradle in which arm rested (passive movement)
- Reference position was maintained actively (by subject's effort) or passively (by cradle)
- After 0-12 sec, other hand moved by subject to subjectively equal position
- Subject's eyes covered throughout the experiment

Experimental Procedure

- Method of adjustment

- Independent variables: type of movement (active or passive) used to place target arm into position, method of maintaining target position after the initial placement (active or passive), delay between positioning reference arm and matching apparent position with opposite arm
- Dependent variable: matching error of arms as measured by difference in elevation (in millimeters) between reference hand and test hand
- Subject's task: move matching arm to a position subjectively equal to that of the reference arm
- 20 trials per condition (Fig. 1); 24 trials per condition (Fig. 2)
- 7 subjects (Fig. 1); 5 subjects (Fig. 2)

Experimental Results

- Judgment of the elevation (vertical position) of the arm (with eyes covered) is more accurate when the arm is actively positioned by the subject than when moved passively into place by an apparatus (χ^2 test, $p < 0.001$).
- Passive versus active maintenance of the arm in its reference position has little effect on accuracy of position judgment.
- With active positioning of the arm, the tendency to underestimate position increases with increasing delay be-

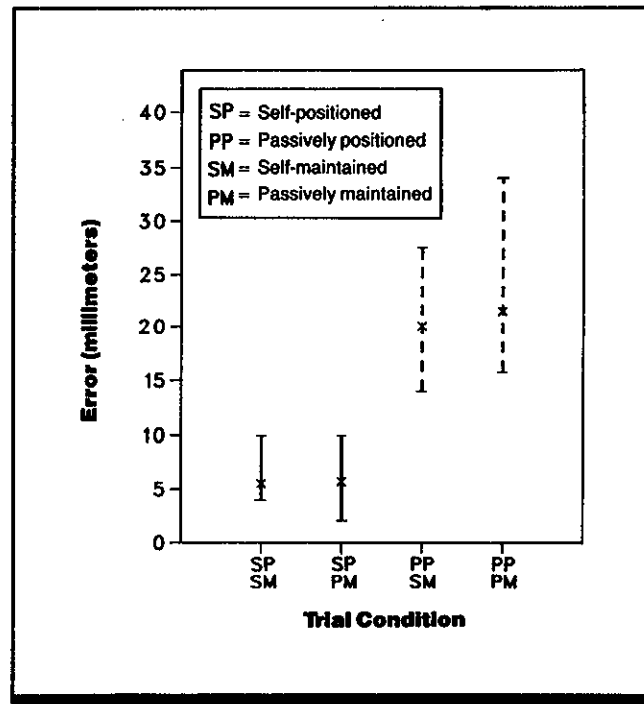

Figure 1. Median error in matching one arm to perceived elevation (vertical position) of the other (reference) arm (measured as vertical distance between index fingers of reference and matching hands). Reference arm was placed and maintained in target position either by active (subject-initiated) or by passive (externally imposed) movement. (From Ref. 1)

tween the placement of the arm and judgment of its position (where apparent position is indicated by raising the opposite arm to an apparent elevation match). With passive positioning, this initial overestimation in vertical position changes to underestimation as delay between positioning and judgment increases.

Variability

Error bars in Figs. 1 and 2 show interquartile ranges for the median scores.

Key References

*1. Paillard, J., & Brouchon, M. (1968). Active and passive movements in the calibration of position

sense. In S. J. Freedman (Ed.), *The neuropsychology of spatially oriented behavior* (pp. 37-55). Homewood, IL: Dorsey.

*2. Paillard, J., & Brouchon, M. (1974). A proprioceptive contribution to the spatial encoding of position cues for ballistic movements. *Brain Research*, 71, 273-284.

Cross References

3.302 Measurement of position sense;

3.312 Perception of arm position: effect of active versus passive movement and practice;

3.319 Perception of knee position; *Handbook of perception and human performance*, Ch. 13, Sect. 2.2

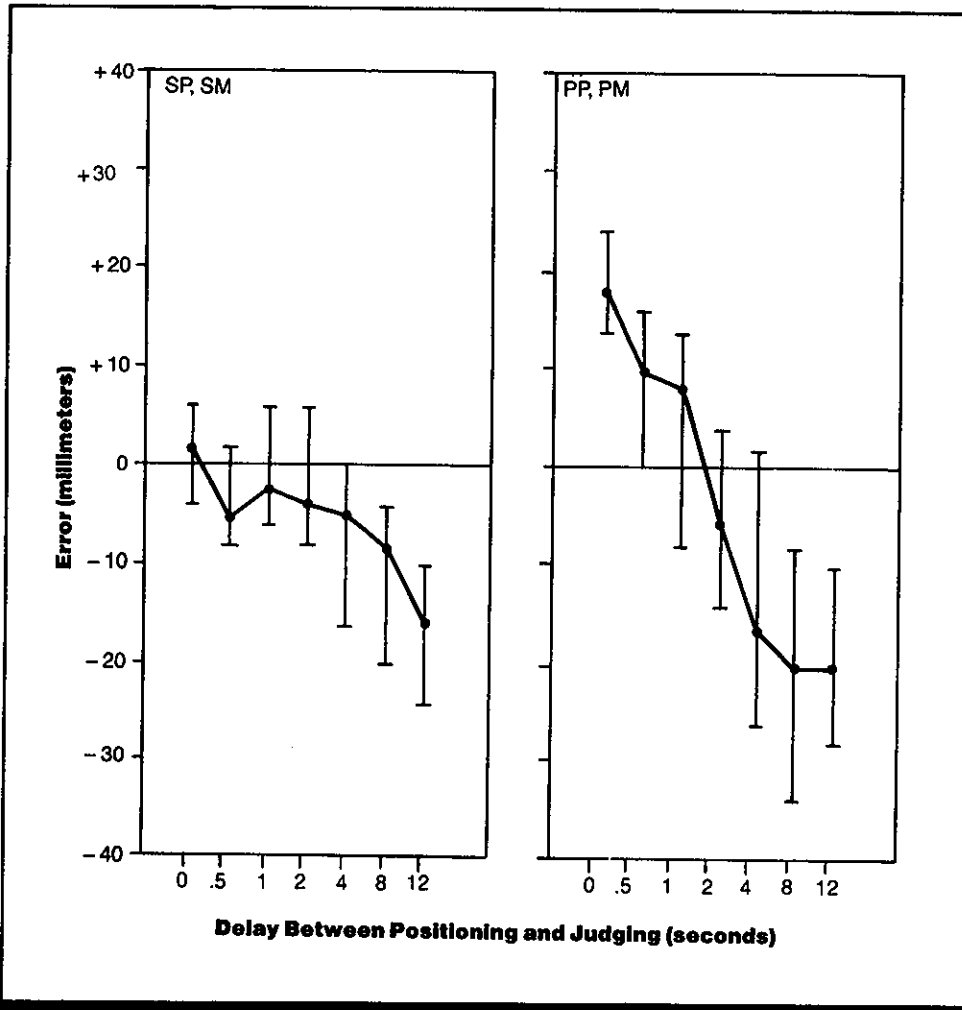

Figure 2. Median error in judging elevation of a target arm by matching its perceived position with the other arm, as a function of the time interval between positioning and judging. **Left panel:** Target arm self-positioned and self-maintained in place. **Right panel:** Target arm passively positioned and passively maintained in place. Error measured as vertical distance between index fingers of target and matching hands. (From Ref. 1)

3.312 Perception of Arm Position: Effect of Active Versus Passive Movement and Practice

Key Terms

Active limb movement; arm position; learning; passive limb movement; position sense; practice; shoulder joint; shoulder rotation

General Description

If the position of one hand is judged by moving the second hand to a perceptually corresponding position, error is much greater when the reference hand has been positioned passively (by the experimenter) rather than actively (by the subject). As the delay between positioning one hand and estimating its position increases, the dispersion (variability) of the error increases and does not change with practice. For both active and passive conditions, increasing the speed of the target positioning movement results in increasing underestimation of vertical arm position; slower-than-normal speeds result in overestimation.

Methods

Test Conditions

Study 1 (Ref. 2)

- With head and trunk position fixed, subject's hands moved along two parallel vertical tracks 60 cm in length at a distance of 60 cm
- Index finger of left hand self-positioned or passively positioned by movement of a cradle in which arm was fixed
- Position was self-maintained or passively maintained
- Subject actively moved right hand into perceptually comparable position after 0-12 sec
- For practice effect, 20 trials per condition per session, two sessions per day; otherwise, 24 trials per condition

Study 2 (Ref. 3)

- Subject held target in left hand with index finger at target's center; in right hand, subject held stylus aligned with index finger
- Target arm moved to meet reference arm at 0.3, 5, or 9.5 m/sec

Experimental Procedure

Study 1

- Method of adjustment
- Independent variables: type of movement (active or passive) in placing and maintaining arm position, day of testing
- Dependent variable: error in positioning right arm as measured by difference between right and left arm positions (mm)
- Subject's task: move right arm along track into a position perceived as equal to the position of the left arm
- 1 trained subject for practice effect; 5 untrained

Study 2

- Independent variable: speed of arm movement
- Dependent variable: error in positioning arm
- Subject's task: touch center of target with stylus
- 6 subjects

Experimental Results

- Accuracy in positioning one arm to the same elevation (vertical position) as the other is greatly increased if the reference arm is self-positioned (actively moved) rather than moved passively into place (chi-square test, $p < 0.001$).
- Active versus passive maintenance of arm position has little effect on positioning accuracy.
- As the delay between positioning one arm and estimating its position increases, position accuracy decreases progressively. For active positioning, subjects underestimate position. For passive positioning, direction of error changes from an overestimation of arm position (+18 mm at zero

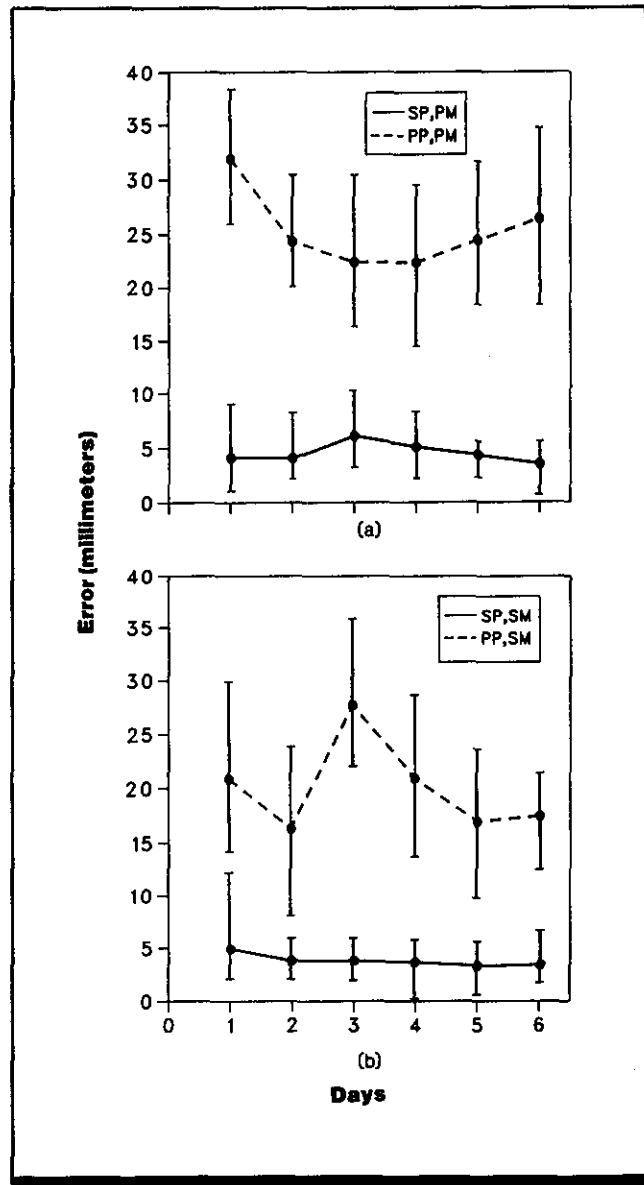

Figure 1. Positioning error of self-positioned (SP) and passively positioned (PP) conditions for (a) passively maintained (PM) and (b) self-maintained (SM) hand positions for 6 days of testing (Study 1). (From Ref. 2)

delay) to an underestimation beginning at 2-sec delay (-6 mm error).

- Positioning accuracy is relatively stable across six days of testing, showing no effects of practice.
- Figure 2 (Study 2) shows increasing underestimation of target position with increasing speed of target positioning movement. Speeds slower than those naturally used result in overestimation.

Variability

Bars represent interquartile ranges for means of 40 trials. Chi-square test was used to assess differences in positioning accuracy between active and passive movements.

Repeatability/Comparison with Other Studies

Results are consistent with those obtained for active and passive movements of the leg (Ref. 1).

Constraints

- Differences between active and passive movement conditions can be affected by the muscle contractions that the different conditions require.
- Only 1 subject was studied for practice effect.

Key References

1. Lloyd, A., & Caldwell, L. S. (1965). Accuracy of active and passive positioning of the leg on the basis of kinesthetic cues. *Journal of Comparative and Physiological Psychology*, 60, 102-106.
- *2. Paillard, J., & Brouchon, M. (1968). Active and passive movements in the calibration of position

sense. In S. J. Freedman (Ed.), *The neuropsychology of spatially oriented behavior* (pp. 37-55). Homewood, IL: Dorsey.

- *3. Paillard, J., & Brouchon, M. (1974). A proprioceptive contribution to the spatial encoding of position cues for ballistic movements. *Brain Research*, 71, 273-284.

Cross References

- 3.302 Measurement of position sense;
- 3.311 Perception of arm position: effect of active versus passive movement;
- Handbook of perception and human performance*, Ch. 13, Sect. 2.1

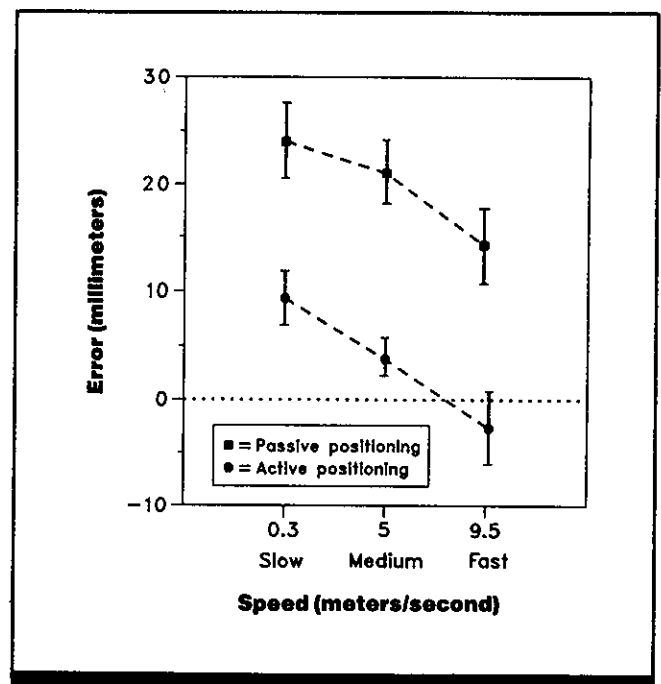

Figure 2. Mean constant error in judging the elevation of the reference arm by matching its perceived position with the other arm, as a function of the speed with which the hand is moved into the reference position (Study 2). "Medium" speed represents the speed spontaneously adopted by subjects in performing such a positioning task. (From Ref. 3)

3.313 Position Matching of Elbow Angle and Arm Orientation

Key Terms

Arm position; elbow angle; elbow rotation; position sense

General Description

The ability to match the orientation (angle) of one arm by positioning the second arm to the same orientation (with eyes closed) is greater when the match is made to the perceived orientation of the limb rather than to the perceived angle at the elbow.

Methods**Test Conditions**

- Right arm movements were directed toward a 40-x 60-cm panel placed parallel to medial plane (longitudinal plane bisecting body into left and right), to the right of the subject; required movements resulted in 0-60 deg forward flexions at shoulder (θ_r) and 60-150 deg extensions at elbow (ϕ_r) (Fig. 1)
- Left arm (matching) movements conducted with upper arm vertical ($\theta_l = 0$) and eyes closed

Experimental Procedure

- Method of adjustment
- Independent variables: angles of flexion at shoulder (θ_r) or extension at elbow (ϕ_r), type of matching required (orientation or angle)
- Dependent variable: positioning error, defined as the difference between left and right elbow angles (ϕ_l and ϕ_r) or left and right limb orientation (β_l and β_r)
- Subject's task: move left arm to position matching perceived angle at right elbow or perceived orientation of right arm
- 6 subjects

Experimental Results

- The accuracy of judging the orientation of the arm is significantly greater than the accuracy of judging the angle of the elbow joint (see "Variability" below).

Variability

The standard deviation of the error was 9.6 deg for matching elbow angles and 6.7 deg for matching limb orientation (t test, $p < 0.005$). Data shown for one subject in Fig. 1 are representative for all subjects tested.

Key References

*1. Soechting, J. F. (1982). Does position sense at the elbow reflect a sense of elbow joint angle or one of limb orientation? *Brain Research*, 248, 392-395.

Cross References

3.302 Measurement of position sense;

3.322 Models for the encoding of joint angle;

Handbook of perception and human performance, Ch. 13, Sect. 2.2

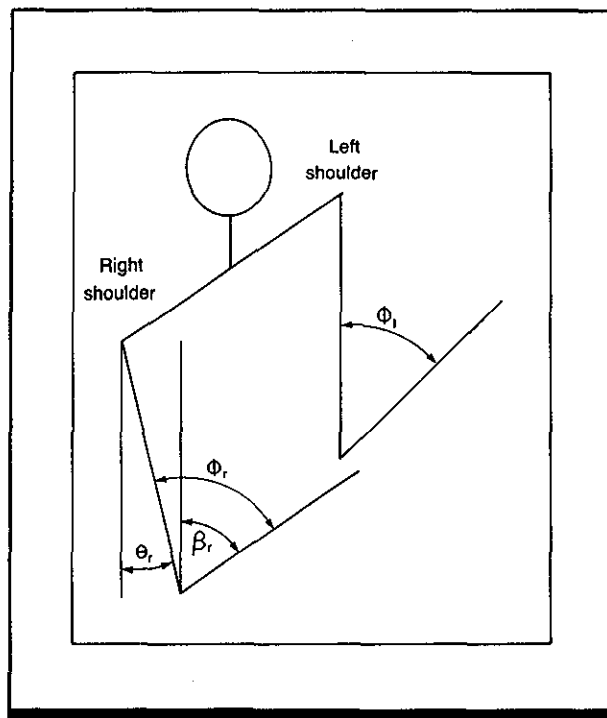

Figure 1. Schematic illustration of angular coordinate system. Both arms are positioned parallel to the median plane. θ_r defines the angle of forward flexion at the shoulder and ϕ_l defines the angle of extension at the elbow. The left arm is vertical ($\theta_l = 0$). The angle β defines the orientation of the forearm (β_l is identical to ϕ_l). (From Ref. 1)

Repeatability/Comparison with Other Studies

The reported results are unaffected by an inequality in the load (weight) on the two arms for 3 subjects tested (Ref. 1).

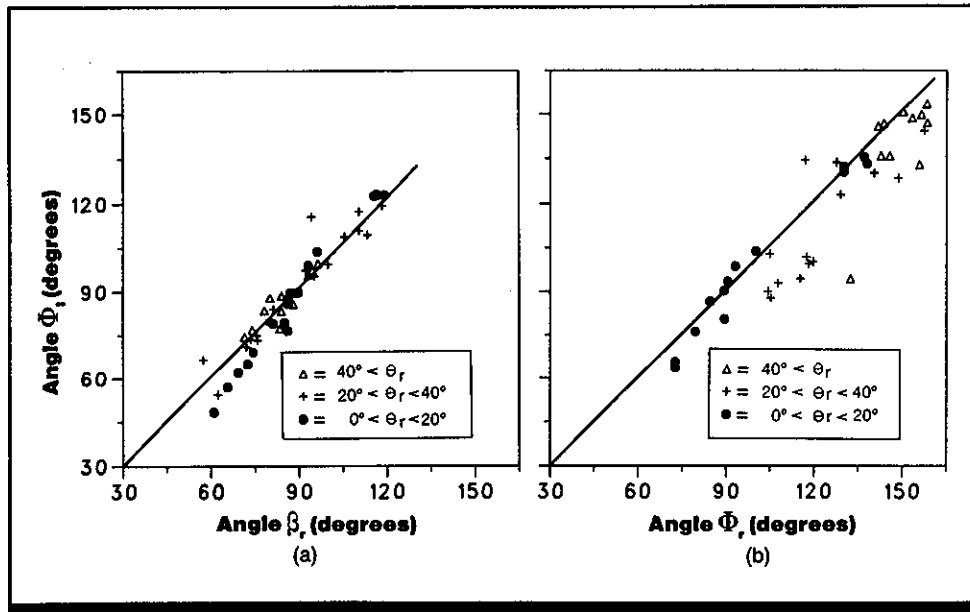

Figure 2. Judgment of limb orientation and joint angle. (a) Subject attempted to match orientations of forearms (i.e., to equalize ϕ_l and β_r). Plotted is the angle between the left arm and the vertical as a function of the angle between the right arm and the vertical. (b) Subject attempted to reproduce the same amount of extension of the elbow (i.e., to equalize ϕ_l and ϕ_r). Plotted is the angle of the left elbow as a function of the angle of the right elbow. The different symbols indicate the range of forward flexion at the right shoulder. Data are for one subject. (From Ref. 1)

3.314 Perception of Elbow Angle

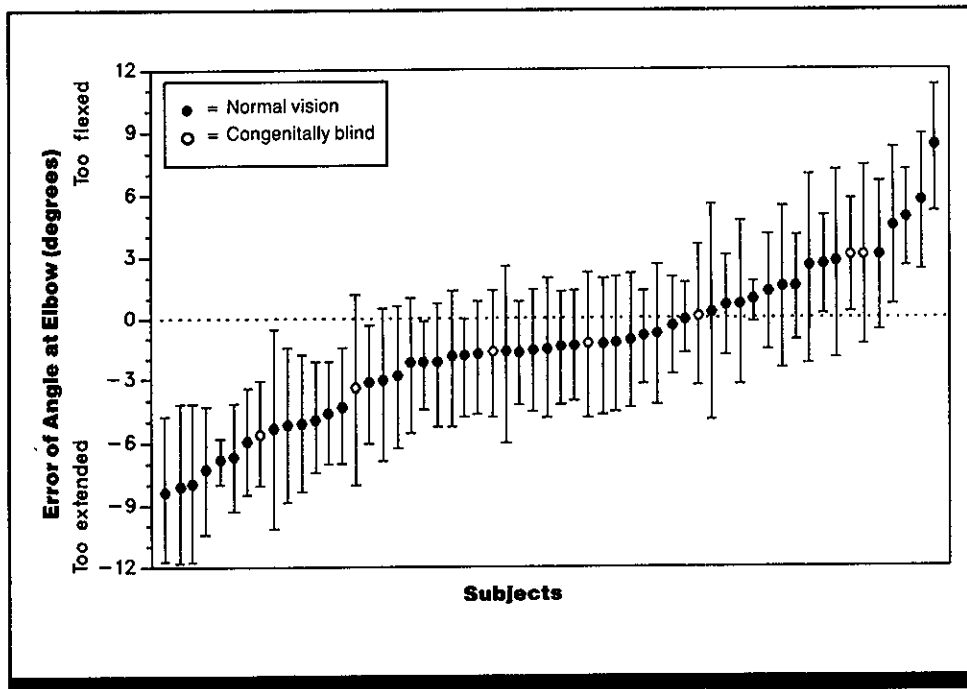

Figure 1. Error in positioning matching arm as a function of the elbow angle of reference (target) arm subject is attempting to match. (From Ref. 4)

Key Terms

Arm position; elbow angle; elbow rotation; muscle loading; muscle vibration; position sense

General Description

Subjects vary considerably in sensing the angle of the elbow, as measured by the ability to position one arm to the same angle as the other arm (with eyes covered). Mean error in position matching is greatest at extreme flexion and

extension target angles, but variability is least at the extreme positions. Loading and/or vibrating the arm muscles gives rise to positional illusions in which the angle of the elbow is misperceived.

Applications

Designs in which operators move the elbow joint against a load and/or with vibration of the arm.

Methods

Test Conditions

- Elbows rested on table top while one forearm was moved into a specified reference position; second arm was moved into a matching position while subject blindfolded
- In Table 1, reference angle was always 50 deg; vibration of 100 Hz

applied to biceps muscle of arm; loads applied by suspending weights (5.4-6.8 kg) from wrist of vibrated arm; it is not clear whether loads were added before or during vibration

- Subject's task: move test arm to same position as reference arm

Experimental Procedure

- Method of adjustment
- Independent variables: elbow angle of reference arm, vibration (presence or absence), load (presence or absence)
- Dependent variables: error in matching elbow angle, as measured by difference between elbow angles of the arms

- Figure 2 based on five matches for each of five reference angles (10, 20, 50, 70, and 80 deg from full extension); Table 1 based on ten nonconsecutive trials per condition
- 50 normal and 7 congenitally blind subjects (Fig. 1); 6 subjects (Fig. 2); 14-15 subjects (Table 1)

Experimental Results

- Subjects differ considerably in mean error for matching the elbow angle of one arm to that of the other arm (with eyes covered).
- Mean errors are greatest for matching reference angles at

extreme flexion or extension. However, variability (standard deviation) is least at the extreme positions.

- Loading a muscle of the arm causes the apparent position of the arm to shift as it would if the muscle in question were lengthened. Loading the biceps muscle causes the arm to feel more extended than it really is. Loading the triceps muscle causes the arm to feel more flexed than it is.

- Vibration of the arm muscles has a similar effect, causing the arm to appear more or less flexed than it really is depending on whether the triceps or the biceps muscle is vibrated.
- Loading a muscle during vibration increases positional error.

Variability

In Fig. 1, variability is not correlated with mean error (error bars show ± 1 standard deviation). The test used five different target angles, but shows only a single measure of variability; therefore any differences versus target angle are obscured. In Fig. 2, standard deviation, which is a measure of the variability in matching the target position, varies with target angle. Variability is least at extreme flexion and extension.

Repeatability/Comparison with Other Studies

The finding that maximal error and minimal variability in judging elbow angle are found at extremes of flexion and extension has also been reported for the ankle joint (Ref. 4).

Constraints

- Caution must be used in applying data presented in Fig. 2 (for reference angles of 10-80 deg) because matching accuracy varies with target angle.
- Magnitude of position errors varies with the frequency of the vibration applied to the arm muscle.

Key References

*1. Erickson, R. P. (1974). Parallel "population" neural coding in feature extraction. In F. O. Schmitt & F. G. Warden (Eds.), *The neurosciences: Third study program* (pp. 155-169). Cambridge: MIT Press.

2. Goodwin, G. M., McCloskey, D. I., & Matthews, P. B. C. (1972). The contribution of muscle afferents to kinesthesia shown by vibration induced illusions of movement and by the effects of paralyzing joint afferents. *Brain*, 95, 705-748.

*3. McCloskey, D. I. (1973). Differences between the senses of movement and position shown by the effects of loading and vibration of muscles in man. *Brain Research*, 63, 119-131.

*4. McCloskey, D. I. (1980). Kinesthetic sensations and motor commands in man. *Progress in Clinical Neurophysiology*, 8, 203-214.

Cross References

3.302 Measurement of position sense;

3.313 Position matching of elbow angle and arm orientation;

3.315 Illusory motion of the elbow with muscle vibration;

3.320 Perception of ankle (foot) position;

Handbook of perception and human performance, Ch. 13, Sects. 2.2, 4.4

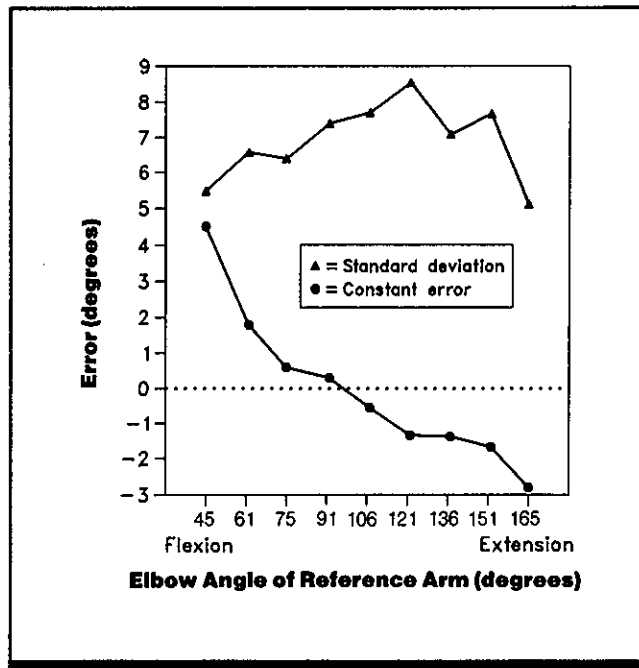

Figure 2. Error in positioning test arm to match elbow angle of reference arm for 50 normal and 7 congenitally blind subjects. Each point represents the average for five target angles from 10-80 deg from full extension. (From Ref. 1)

Table 1. Mean error (± 1 standard deviation) in matching angle of left elbow joint to right elbow angle of 50 deg from full extension, with and without vibration and loading of biceps muscle. (From *Handbook of Perception and Human Performance*, adapted from Ref. 3)

Subject	Control (deg)	Load Alone (deg)	Vibration Alone (deg)	Vibration Plus Load (deg)
1	-0.8 \pm 0.95	+1.6 \pm 1.77 ^b	+6.0 \pm 3.23 ^c	+ 4.9 \pm 3.70
2	-4.5 \pm 1.58	+0.9 \pm 1.90 ^c	+0.9 \pm 1.17 ^c	+ 7.7 \pm 2.75 ^a
3	-0.1 \pm 1.90	+6.6 \pm 3.64 ^c	+8.8 \pm 2.81	+12.9 \pm 1.71 ^a
4	-0.4 \pm 1.61	+4.3 \pm 0.44 ^c	+3.1 \pm 4.11 ^b	+10.9 \pm 2.88 ^a
5	-3.3 \pm 1.39	+1.6 \pm 1.58 ^c	-1.0 \pm 1.45 ^b	+ 3.6 \pm 1.17 ^a
6	-7.5 \pm 2.12	+0.3 \pm 2.12 ^c	+6.4 \pm 2.15 ^c	+11.9 \pm 1.08 ^a
7	-3.8 \pm 2.12	+5.0 \pm 3.86 ^c	+5.2 \pm 4.46 ^c	+ 7.8 \pm 3.98
8	+0.7 \pm 1.45	+1.9 \pm 2.28	+3.3 \pm 2.85 ^b	+ 6.6 \pm 1.77 ^d
9	-5.4 \pm 1.99	+0.6 \pm 1.26 ^c	+4.3 \pm 1.61 ^c	+ 4.7 \pm 3.26
10	-2.7 \pm 1.49	+0.5 \pm 0.70	+4.8 \pm 2.47 ^c	+ 3.7 \pm 2.06
11	-2.7 \pm 2.02	+0.7 \pm 1.64	+0.2 \pm 1.74	+ 7.0 \pm 1.52
12	-2.3 \pm 2.28	+5.3 \pm 1.01	+2.1 \pm 1.42	+ 5.8 \pm 1.17 ^a
13	-1.9 \pm 2.28	+3.4 \pm 2.81	+4.0 \pm 2.47 ^a	+ 7.9 \pm 1.30 ^a
14	0.0 \pm 2.02	+1.4 \pm 2.91	+3.2 \pm 1.01 ^c	+ 5.8 \pm 0.76 ^a
15	-1.2 \pm 2.02	+3.4 \pm 3.10	—	—
Mean	-1.7	+2.5	+3.7	+ 7.2

Mean error is the average amount by which the arm movement exceeded or fell below the target value. Standard deviation indicates the dispersion of errors around the mean error.

Positive values indicate errors in extension; negative values indicate errors in flexion. Control condition is with no loading and no vibration.

- ^aSignificantly different from control values ($p < 0.05$).
- ^bSignificantly different from control values ($p < 0.01$).
- ^cSignificantly different from control values ($p < 0.001$).
- ^dSignificantly different from vibration-alone values ($p < 0.01$).
- ^eSignificantly different from vibration-alone values ($p < 0.001$).

3.315 Illusory Motion of the Elbow with Muscle Vibration

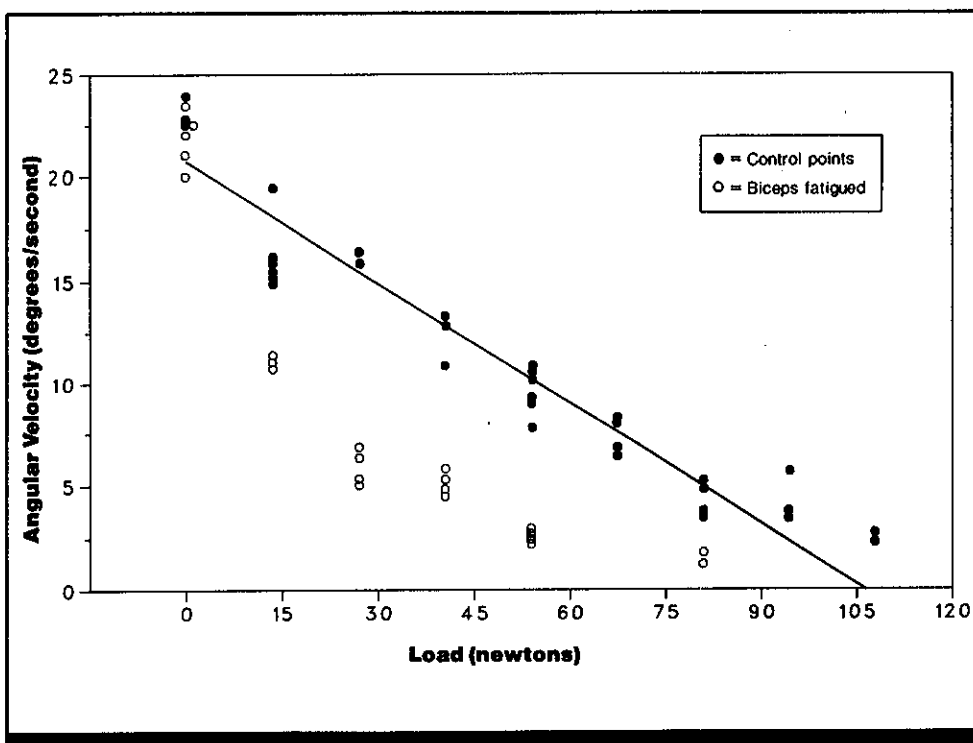

Figure 1. Angular velocity of the illusory movement of the elbow joint into extension, induced by vibration of the biceps muscle of the arm, as a function of the load at the wrist borne by tensing the biceps. In fatigue condition, biceps muscle fatigued by supporting a weight before velocity measurements were made and load imposed continuously during measurements; in control condition, rest periods permitted between velocity measurements at each load level. (From Ref. 2)

Key Terms

Apparent arm movement; arm movement; arm position; elbow movement; elbow rotation; illusory limb movement; joint-movement sense; muscle contraction; muscle fatigue; muscle loading; muscle sense; muscle vibration; position sense

General Description

When 100-Hz vibration is applied to the biceps muscle of the arm, a reflex contraction of the muscle causes the arm to bend involuntarily (the tonic vibration reflex). The vibration also produces the illusion of arm movement (the arm feels

as if the elbow joint were being extended, i.e., as if the vibrating muscle were lengthening continuously). The velocity of this illusory movement slows as the load borne by the muscle increases and as muscle fatigue increases.

Methods

Test Conditions

- Elbows rested on table top while tendon of biceps muscle of reference arm was vibrated (100 Hz) and that arm was gently restrained by experimenter from flexing under the tonic vibration reflex
- Blindfolded subjects attempted

to match angular velocity of illusory movement with opposite arm

- Loads applied by suspending weights from wrist of reference arm (1.36 kg increments to a total of ~8.2 kg)
- No fatigue condition: recovery periods permitted between support periods of 30 sec or less
- Fatigue condition: subjects supported ~8.2-kg weight until they judged biceps to be fatigued, then

matched velocity of reference arm as weight decreased in 1.36-kg increments (no recovery periods)

Experimental Procedure

- Method of adjustment
- Independent variables: load (presence or absence), biceps condition (normal or fatigued)
- Dependent variables: perceived

velocity of illusory movement as measured by velocity of matching arm

- Subject's task: move test arm at same apparent velocity as reference arm
- Number of subjects varied across experiments; including both subjects with extensive practice and subjects briefly trained to be accustomed to sensations and movements produced by vibration

Experimental Results

- The velocity of illusory arm movement produced by vibration of the biceps muscle decreases as the magnitude of an applied load increases (t test, $p < 0.001$).
- In 6 of 9 subjects, fatigue of the biceps muscle caused a marked slowing of angular velocity of the illusory movements at all added loads.

Variability

Test of significance for effect of fatigue was that all points collected during loading under fatigue were below a line

Constraints

- The illusion can be heightened by passive extension of the vibrated arm. It can be diminished by tensing of the muscles.
- Because subjects' self-reports were used to determine extent of muscle fatigue, the actual degree of fatigue probably varied across subjects.

Key References

1. Goodwin, G. M., McCloskey, D. I., & Matthews, P. B. C. (1972). The contribution of muscle afferents to kinesthesia shown by

vibration induced illusions of movement and by the effects of paralyzing joint afferents. *Brain*, 95, 705-748.

*2. McCloskey, D. I. (1973). Differences between the senses of movement and position shown by the effects of loading and vibration of muscles in man. *Brain Research*, 63, 119-131.

Cross References

3.314 Perception of elbow angle;
Handbook of perception and human performance, Ch. 13, Sect 4.4

two standard errors of estimate below the line of best fit drawn through the previously collected velocity-load points. Although Fig. 1 indicates that velocity-load points fall on a straight line during fatigue, this was not true in all subjects, possibly because of the changing state of fatigue throughout the procedure.

Repeatability/Comparison with Other Studies

These results are similar to those reported in Ref. 1

- There are large individual differences in the velocity of illusory motion perceived and in the slopes of the velocity-load relationship.
- Vibration also produces a separate and independent illusion of altered limb position, as though the vibrated muscle were longer than its objective length (CRef. 3.314).

3.316 Perception of Shoulder (Arm) Position

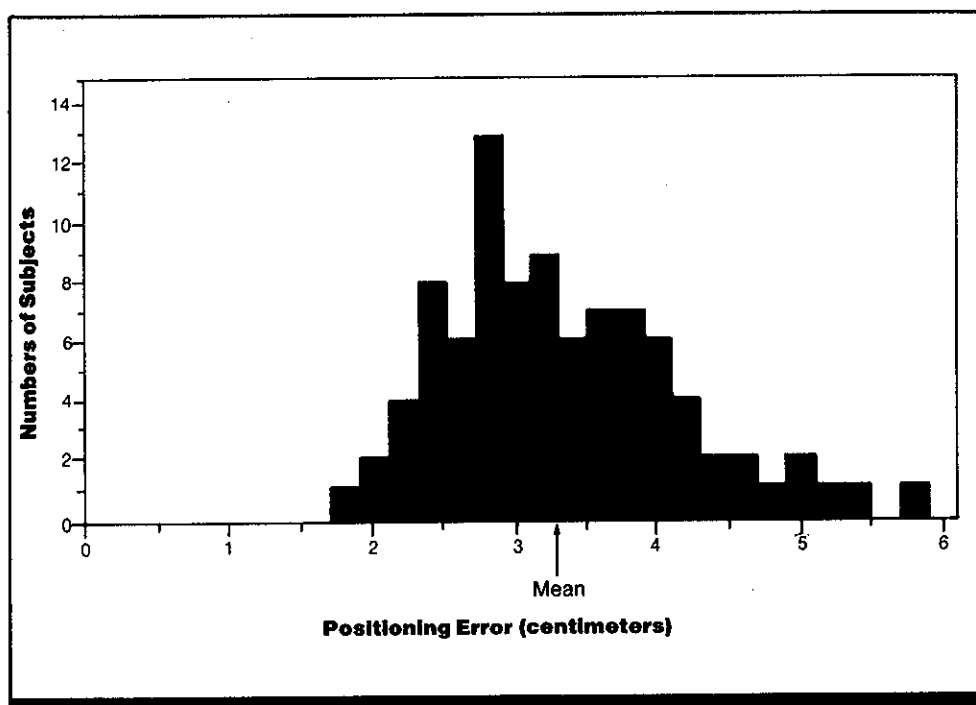

Figure 1. Frequency distribution of shoulder positioning error. (From Ref. 1)

Key Terms

Arm position; arm-positioning accuracy; memory for limb position; position sense; shoulder joint; shoulder rotation

General Description

There is considerable variability across individuals in the ability to place the shoulder (with eyes closed) so that the position of the outstretched arm matches the position held a few seconds earlier.

Methods

Test Conditions

- Target board placed in front of the subject at a distance of the extended arm and with the center aligned with the subject's shoulder

- 48 reference targets arranged in four concentric groupings of 12
- Index finger extended to touch reference target, after which subject closed eyes and withdrew hand to side
- Following a brief pause, arm raised ~90 deg and index finger

again extended toward target (with eyes still closed)

Experimental Procedure

- Method of adjustment
- Independent variable: location of target on concentric ring
- Dependent variable: positioning

error as measured by distance between reference target and placement positions

- Subject's task: with eyes closed, replace index finger at target location just previously held
- One trial per target location
- 91 subjects

Experimental Results

- Average error in placing the shoulder in a previously held position is 3.3 cm. (Subject touched target with outstretched finger, lowered arm, then attempted to touch target again with eyes closed. Error is distance of index finger from target.)
- There are large differences among individuals in the accuracy of shoulder positioning (see "Variability" below).
- Largest and smallest positioning errors tended to be grouped in certain locations of the frontal field of the shoulder for a given individual. The largest errors were generally found for reference targets located along the 2 o'clock and

4 o'clock directions of the frontal field, while the smallest errors were for target locations nearest the center of the field.

- Mild distraction or moderate degrees of fatigue did not affect accuracy of position sense.

Variability

Positioning errors are means of responses to 48 reference targets per subject. Mean errors ranged from 1.7-5.8 cm. Individual means were corrected to a standard arm length of 70 cm. Daily variation of accuracy in individuals was much less than variation among individuals.

Constraints

- Only single trials per reference point were studied. Multiple trials would show whether distribution around a given reference point is random or patterned.
- Although vertical swaying of the body was minimal, recorded errors in pointing might include the effects of changes in vertical orientation of the body.

Repeatability/Comparison with Other Studies

Smaller errors are seen using a stylus held in one hand to point to a target plate held in the opposite hand; median error was 8 mm with active movement of the target hand and 18 mm with passive placement of target hand (Ref. 2).

Key References

*1. Cohen, L. A. (1958). Analysis of position sense in human shoulder. *Journal of Neurophysiology*, 21, 550-562.

2. Paillard, J., & Brouchon, M. (1968). Active and passive movements in the calibration of position sense. In S. J. Freedman (Ed.), *The neuropsychology of spatially oriented behavior* (pp. 37-55). Homewood, IL: Dorsey.

Cross References

3.302 Measurement of position sense;

3.317 Memory for shoulder (arm) position;

Handbook of perception and human performance, Ch. 13, Sect. 2.1

3.317 Memory for Shoulder (Arm) Position

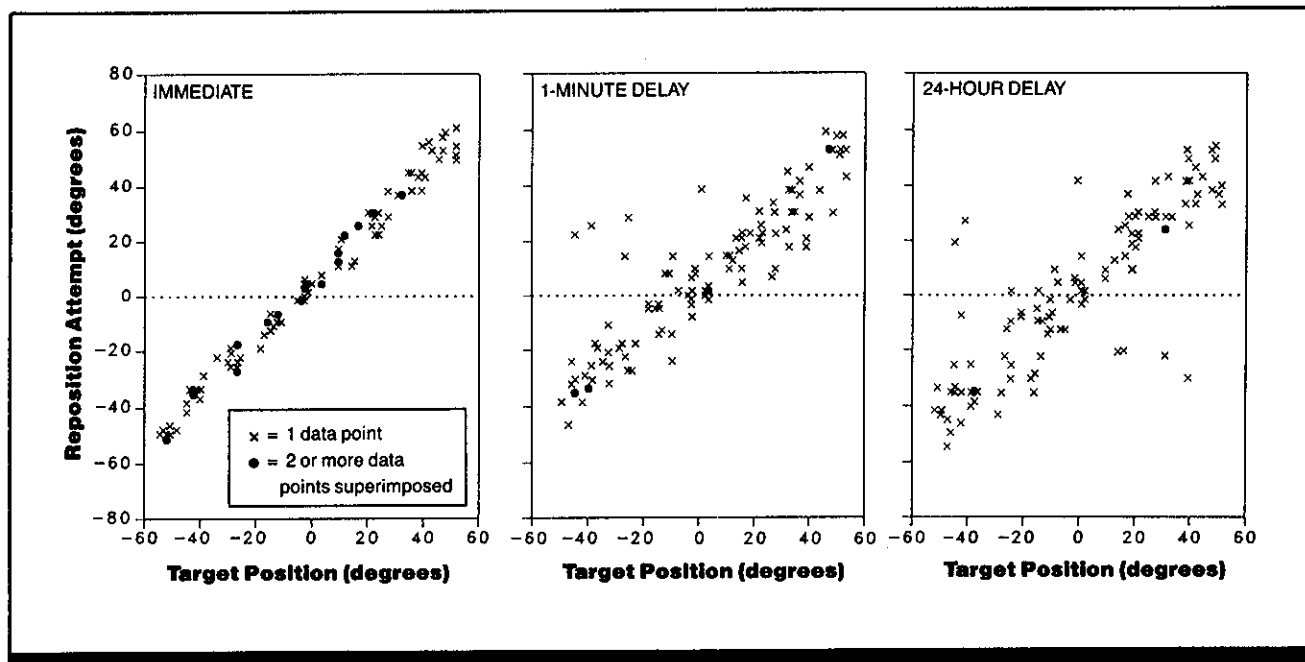

Figure 1. Accuracy of repositioning arm to match target position (a) immediately after original placement, (b) with 1-minute delay, and (c) with 24-hour delay. (From *Handbook of perception and human performance*, based on data from Ref. 1)

Key Terms

Arm position; arm-positioning accuracy; memory for limb position; position sense; shoulder joint; shoulder rotation

General Description

Subjects can remember positions of the shoulder with an accuracy that decreases slightly with increased time interval between target presentation and match from memory. Errors tend to be in the direction of the horizontal position. Variability in matching target position increases with length of the time interval.

Methods

Test Conditions

- Outstretched arm supported in a sling passively moved to target (reference) position within range of 55 deg above (+) to 55 deg below (-) the horizontal (0 deg); arm maintained in target position for

5 sec before being returned to the side; eyes of subject were closed or covered during arm positioning

- Immediately following the return of arm to the side, or after delays of 1 min or 24 hr, subjects attempt to reposition arm at target position using the extended index finger as a pointer

Experimental Procedure

- Method of adjustment
- Independent variables: target position (angle of shoulder joint in degrees), length of delay
- Dependent variable: accuracy of repositioning as measured by difference (in deg) between target and

test positions of the extended index finger

- Subject's task: remember position of arm and return arm to this position when instructed
- 25 trials per subject per delay length; several days or weeks between testing with different delay lengths
- 5 subjects

Experimental Results

- As the delay between the passive positioning of the arm and its active repositioning increases, accuracy in reproducing the target position decreases. Coefficients of correlation between target position and matching position, derived from least-squares linear regression analyses of the data are 0.99, 0.89, and 0.85 for no delay, 1-min delay, and 24-hr delay, respectively.

Variability

With increased delays, the variability of positioning responses increases (least-squares regression yields slopes of 1.01 for immediate matches, 0.790 for 1-min matches, and 0.809 for 24-hr matches). Errors tend to be in the direction of the horizontal position of the shoulder.

Key References

*1. Clark, F. J., & Burgess, R. C. (1984). *Long-term memory for position of shoulder joint*. Unpublished manuscript, University of Nebraska Medical Center, Omaha.

Cross References

3.302 Measurement of position sense;

3.316 Perception of shoulder (arm) position;

Handbook of perception and human performance, Ch. 13, Sect. 2.2

3.318 Perception of Finger Displacement

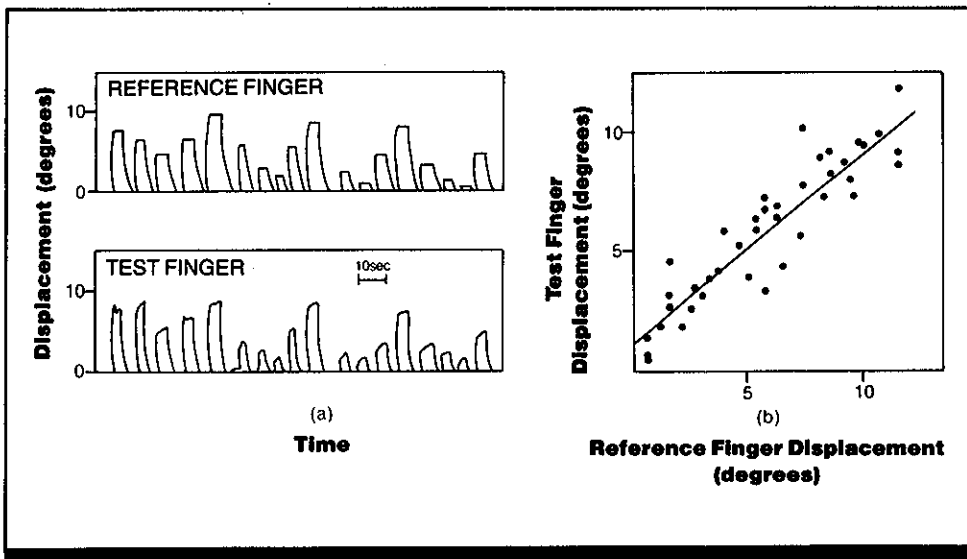

Figure 1. Perception of passive displacements of the right index finger estimated from matched displacements of the left index finger by one subject. (a) Sequence of trials showing the displacement of the proximal interphalangeal (second) joint of the right index (reference) finger and perceived displacement, as reflected in displacements of the proximal interphalangeal joint of the left index (test) finger. (b) Test finger (left index) displacement as a function of reference finger (right index) displacement. Regression line fitted by method of least squares. Slope = 0.76, ordinate intercept = 1.13. Data shown are for 9 subjects. (From Ref. 5)

Key Terms

Finger joint; finger position; muscle loading; muscle sense; position sense

General Description

Judgment of finger displacement is independent of the force exerted by the finger unless the force is **isometric**. With isometric loading (the subject exerts different forces with the finger, but the amount of finger displacement remains

constant), judged finger displacement correlates with the force applied by the finger rather than its actual displacement. Although displacements in finger position can be accurately sensed, humans lack an awareness of the true *static* position of the fingers (data not presented here).

Methods

Test Conditions

- Forearms rested on a table top, with reference (right index) finger attached to motor-driven frame that could move finger through a specified angle and/or impose a force
- For no-force condition (Fig. 1), reference finger moved passively at a constant angular velocity of 5 deg/sec and held in test position for 5 sec; after 1 sec at reference position, the test (left index) finger was moved by subject to a perceptually matching displacement
- For applied-force condition (Fig. 2), the finger was loaded with a constant initial force and then a ramp and hold change in force was applied, causing displacement of reference finger

tion for 5 sec; after 1 sec at reference position, the test (left index) finger was moved by subject to a perceptually matching displacement

- For isometric condition (Fig. 3), subject exerted force against a device that moved the reference finger through the same 4-deg excursion irrespective of the force
- Subject was unaware of the conditions of the experiment; subject used test finger to match perceived displacement of reference finger

Experimental Procedure

- Method of adjustment
- Independent variables: displacement of reference finger, force applied to reference finger

- Dependent variable: accuracy of perceived displacement as measured by difference between displacement of reference and test fingers
- Subject's task: reproduce displacement of reference finger by moving test finger by the same amount
- 6, 8, or 9 subjects

Experimental Results

- When the finger is moved passively (not under subject's control), judgment of finger displacement is relatively accurate (Fig. 1, *F* test for significance of regression line shown in Fig. 1b, $p < 0.01$).
- Accuracy in judging finger displacement is unaffected by an imposed load on the finger (Fig. 2).

- When an isometric force is exerted by the finger, judged finger displacement correlates with magnitude of the force rather than with the objective displacement of the finger (Fig. 3).
- All 9 subjects were unable to recognize reliably the presence or absence of movement of < 1 deg.

Variability

Although the data figures plot performance of a single observer, they are representative of all subjects tested under each condition.

Repeatability/Comparison with Other Studies

Results are similar to those reported for the ankle (Ref. 4) but are at variance with those reported for the elbow (Ref. 3). Other studies reveal the lack of a static-position sense for the interphalangeal joints of the fingers (Refs. 1, 2).

Key References

1. Clark, F. J., Burgess, R. C., & Chapin, J. W. (1983). Humans lack a sense of static-position of the fingers. *Society for Neuroscience Abstracts*, 9, 1033.
2. Clark, F. J., Burgess, R. C., & Chapin, J. W. (1985). *Proprioception with the interphalangeal joint of the index finger: Evidence for a movement sense without a static-position sense*. Manuscript submitted for publication.
3. McCloskey, D. I. (1973). Differences between the senses of movement and position shown by

the effects of loading and vibration of muscles in man. *Brain Research*, 63, 119-131.

4. Monster, A. W., Herman, R., & Altland, N. R. (1973). Effect of the peripheral and central "sensory" component in the calibration of position. In J. E. Desmedt (Ed.), *New developments in electromyography and clinical neurophysiology* (Vol. 3, pp. 383-403). Basel: Karger.

*5. Rymer, W. Z., & D'Almeida, A. (1980). Joint position sense: The effects of muscle contraction. *Brain*, 103, 122.

Cross References

- 3.302 Measurement of position sense;
 3.307 Detectability of finger movement;
 3.314 Perception of elbow angle;
 3.320 Perception of ankle (foot) position;

Handbook of perception and human performance, Ch. 13, Sect. 2.2

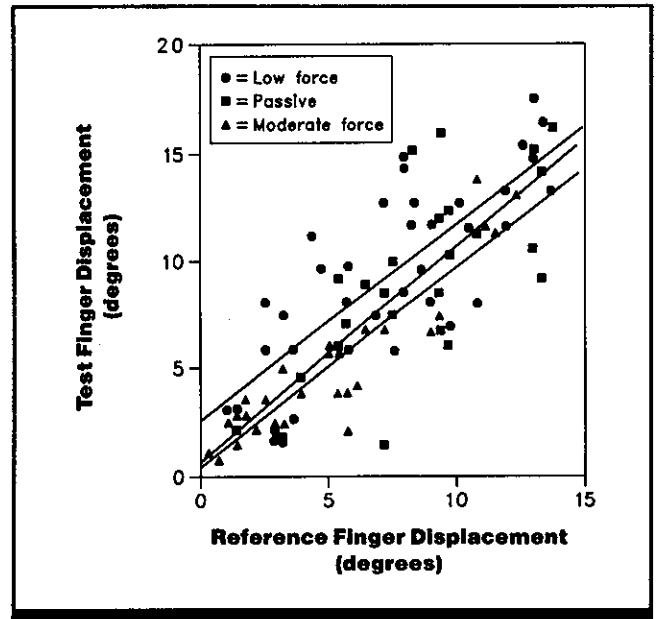

Figure 2. Perception of displacement in a finger supporting a load. The magnitude of perceived displacement was tested under three conditions for one subject. Slopes and intercepts of regression lines fitted by method of least squares are 0.92 and 2.6 for low force, 0.94 and 0.4 for moderate force, and 1.02 and 0.6 for passive movement. Regression slopes are not significantly different from each other (t test, $p > 0.05$). Data shown are for 8 subjects. (From Ref. 5)

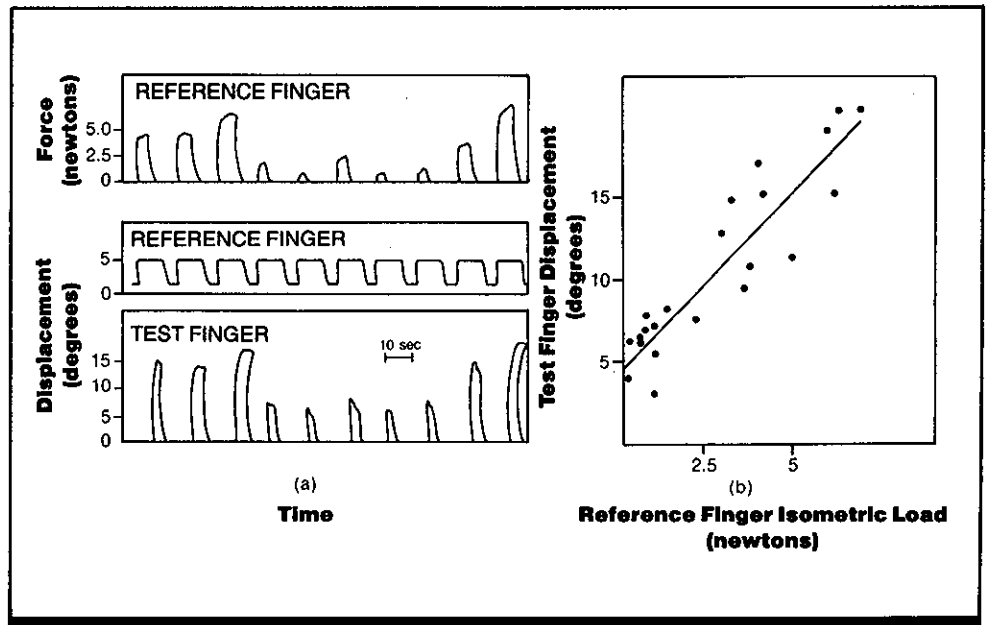

Figure 3. Interference with the estimation of joint position by the production of isometric force. (a) Reference finger (right index) was periodically subjected to external flexion movements while the subject tried to match a visually displayed target force by increasing flexion force. The resultant force is shown in the upper panel. Unknown to the subjects, all finger displacements (flexions) were 4 deg in magnitude. The final position of the right index finger was estimated during the "hold" or isometric phase of the movement, using matched movements of the left index (test) finger, which are depicted in the lower panel. (b) Magnitude of perceived finger displacement as a function of isometric force. The slope of the fitted regression line, a measure of error magnitude, is 2.25 deg/N and the ordinate intercept is 4.55 deg (versus 4 deg actual movement). Data shown are for 1 subject. (From Ref. 5)

3.319 Perception of Knee Position

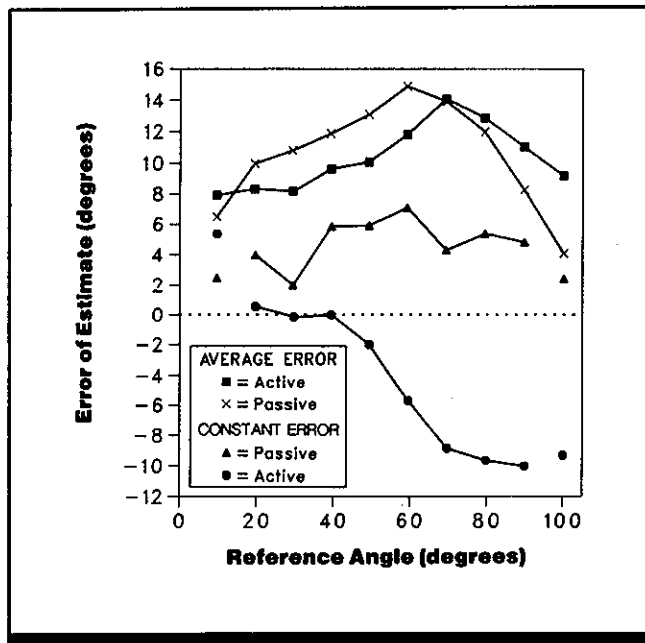

Figure 1. Error in estimating (matching) knee angle for active and passive positioning of the knee. Constant error (lower curves, not connected to end points) is the arithmetic mean of the errors in estimating joint angle, which indicates the bias in subjects' perception of position; average error (upper curves, connected to end points) is the mean of the absolute values of judgment errors, which gives an estimate of subjects' overall accuracy. Positive values indicate error in the direction of greater extension; negative values, in the direction of greater flexion. (From Ref. 3)

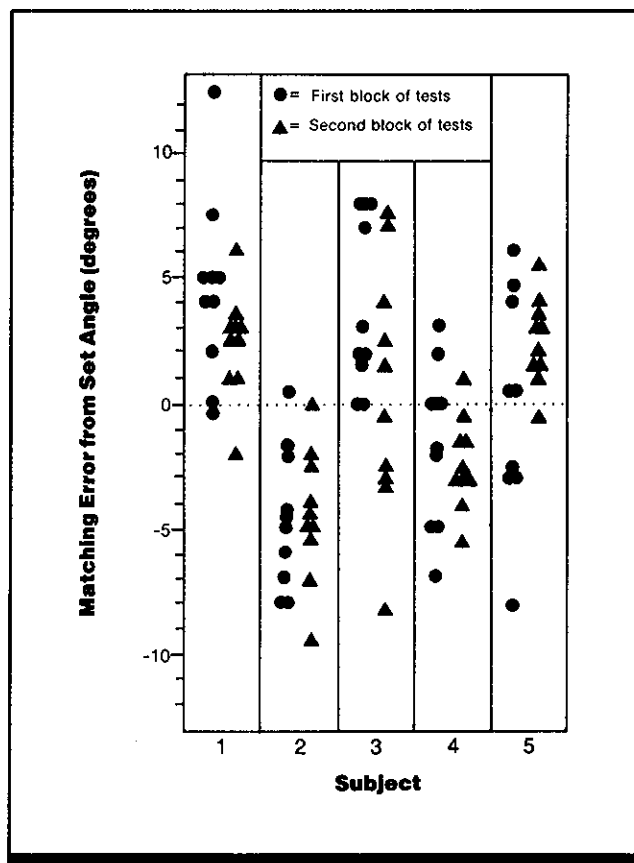

Figure 2. The effect of experience on individual subjects' accuracy of matching test and target knee joint angles. A positive error indicates the test knee was more extended than the target knee; a negative error indicates that the test knee was more flexed. Each subject had a different bias angle (as indicated by the shift in the scores away from zero), but comparable scatter around the bias angle. There was no statistically significant difference in the means or standard deviations in the scores for the first block and the scores for the second block. (From Ref. 1)

Key Terms

Active limb movement; knee angle; knee joint; knee rotation; learning; leg position; memory for limb position; passive limb movement; position sense; practice

General Description

Accuracy in bending one knee joint to the same angle as the other knee joint (with eyes covered) is affected by whether the reference knee is positioned actively (by the subject) or

passively (by the experimenter). The time between positioning of the reference and test knees generally has no effect on accuracy, nor does prior experience in a positioning task with no feedback.

Methods

Test Conditions

- For active condition (Fig. 1), subject moved knee to an angle verbally specified; for passive condition, the knee was passively positioned and subject verbally estimated perceived angle
- For measuring the effect of practice (Fig. 2), left knee was fixed in position, and right knee angle was passively changed by 5 deg at < 1 deg/min, starting from a position perceived as matched by the subject. The knee angle was re-

matched by passive positioning of right leg as verbally directed by the subject. The first block of tests took place over 2 days and the second block took place over 2 subsequent days

- For measurements involving positioning delay, right leg was passively positioned and maintained for 1 min while subject matched its position with left leg (direct comparison); or right leg was passively moved into reference position, maintained for 15 sec, then returned to its resting position; 45 sec later, left leg actively matched the

reference position (memory match)

- The experimental apparatus was set up so the subjects could not see the position of their legs

Experimental Procedure

- Method of adjustment
- Independent variables: reference angle of knee, type of positioning movement (active or passive), time between positioning of reference and test (matching) knee
- Dependent variable: error of match as measured by difference (deg) between reference angle and test angle of knees

- Subject's tasks: position one knee to the perceived angle of the other knee; verbally judge the direction of misalignments and direct the experimenter how to move the leg to achieve a rematch
- Figure 1 based on 48 trials per reference position; Fig. 2 based on four extensions, four flexions and two control (no movement) trials per block of tests; memory measurements based on 24 trials per angle
- 40 subjects (Fig. 1); 5 subjects (Fig. 2); 8 subjects (for memory match)

Experimental Results

- When the knee joint is passively moved into a given position, knee angle tends to be overestimated (knee joint appears more extended than it really is) (Fig. 1).
- When the subject actively positions the leg to match a given knee joint angle, accuracy is greatest for the range of angles involved in normal walking (10-40 deg) (Fig. 1).

- Practice in judging knee position (without feedback regarding accuracy) does not affect performance (Fig. 2).
- Subjects generally are equally accurate in matching the knee angle of the test leg to the knee angle of the reference leg regardless of whether matches are done simultaneously (while reference angle is being held) or after a short delay (45 sec after reference leg has returned to resting position) (Ref. 2; data not shown).

Key References

*1. Clark, F. J., Horch, K. W., Bach, S. M., & Larson, G. F. (1979). Contribution of cutaneous and joint receptors to static knee-position sense in man. *Journal of Neurophysiology*, 42, 877-888.

2. Horch, K. W., Clark, F. J., & Burgess, P. R. (1975). Awareness of knee joint angle under static conditions. *Journal of Neurophysiology*, 38, 1436-1447.

*3. Lloyd, A., & Caldwell, L. S. (1965). Accuracy of active and passive positioning of the leg on the basis of kinesthetic cues. *Journal of Comparative and Physiological Psychology*, 60, 102-106.

Cross References

3.302 Measurement of position sense;

Handbook of perception and human performance, Ch. 13, Sect. 2.2

3.320 Perception of Ankle (Foot) Position

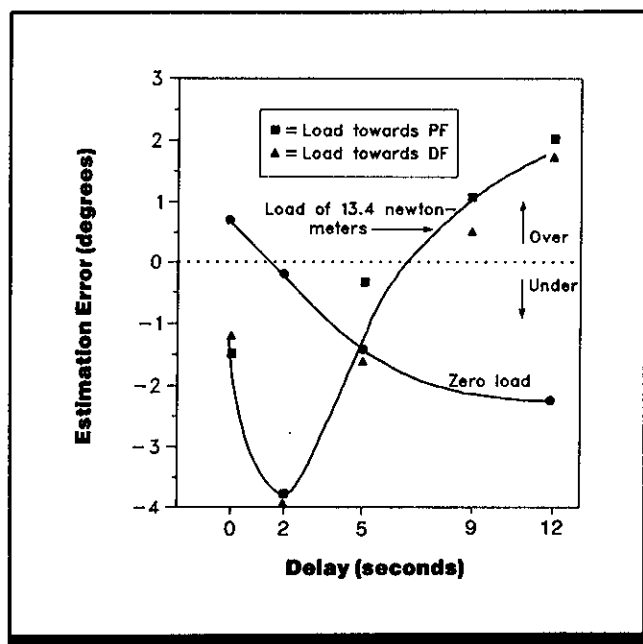

Figure 1. Error in estimating ankle position as a function of delay between positioning reference foot and matching perceived foot position with other foot, for load and no-load conditions. Load was toward downward rotation (plantarflexion, PF) or upward rotation (dorsiflexion, DF), of toes. Negative error indicates excessive plantarflexion of matching foot (underestimation of foot position). (From Ref. 1)

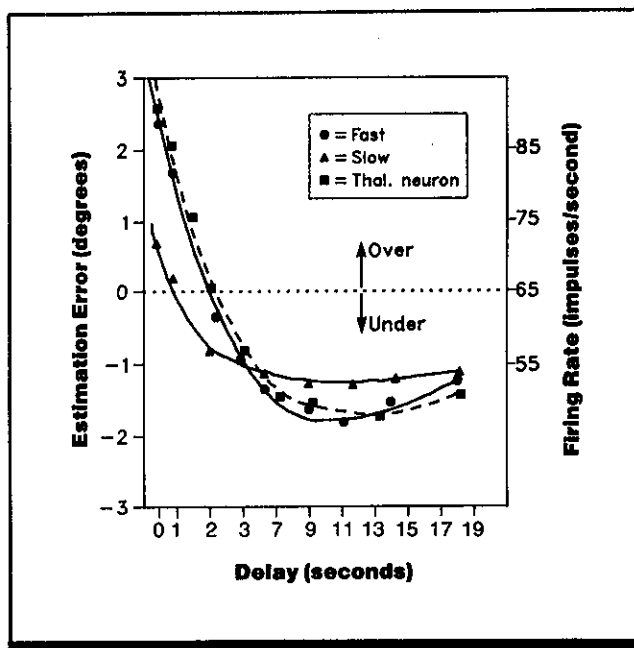

Figure 2. Estimation error for fast and slow passive positioning of the reference foot with increasing delay. For comparison, square symbols show rate of decay of discharge of a thalamic neuron in the monkey during maintained wrist position as given in Ref. 2. (From Ref. 1)

Key Terms

Ankle joint; ankle rotation; foot position; muscle loading; position sense

General Description

The perceived position of one foot (reference foot) flexed at the ankle, as estimated by matching its position with the other (matching) foot, varies with the muscle load on the reference foot and the delay between positioning the reference foot and the matching foot.

Methods

Test Conditions

- Feet rested in two parallel rotary cradles, with knees flexed at 45 deg
- Reference foot moved by subject into dorsiflexion (ankle rotated to raise toes) or plantarflexion (ankle rotated to lower toes) against a load

torque of 13.4 N-m; other (matching) foot moved into perceptually comparable position after 0-12 sec (Fig. 1)

- Neither visual nor auditory feedback is present except during initial training period
- Under no load, reference foot moved passively into position at

either a slow speed or a speed 2.5 times as fast (exact parameters not specified); test foot moved after 0-18 sec (Fig. 2)

Experimental Procedure

- Method of adjustment
- Independent variables: length of delay, speed of flexion, direction of flexion, muscle load

- Dependent variable: position estimation error as measured by difference in rotation of test foot and reference foot
- Subject's task: position matching foot at same angle of flexion as reference foot
- 1 practiced subject

Experimental Results

- Under conditions of no imposed load, subjects' judgments of the position of the foot change from overestimation (too much upward flexion) to underestimation (too much downward flexion) as the delay between positioning of the reference and matching foot increases.
- Under an imposed load, the apparent flexion of the foot is first increasingly underestimated, but then becomes overestimated, as the delay between positioning of the reference and matching foot increases.

- The direction of the torque applied to the reference foot (upward or downward) has no effect on position judgment errors.

Variability

No information on variability was given.

Repeatability/Comparison with Other Studies

The effects of delays on judging foot position are similar to those found for the arm (Ref. 3) and relate well with neurological studies from the monkey thalamus (Ref. 2).

Constraints

- The interaction between muscle load and length of delay can be expected to vary with the load on the muscle.

Key References

*1. Monster, A. W., Herman, R., & Altland, N. R. (1973). Effect of the peripheral and central "sensory" component in the calibration of position. In J. E. Desmedt (Ed.), *New developments in electromyog-*

raphy and clinical neurophysiology (Vol. 3, pp. 383-403). Basel: Karger.

2. Mountcastle, V. B., Poggio, G. F., & Werner, G. (1963). The relation of thalamic cell response to peripheral stimuli varied over an intensive continuum. *Journal of*

Neurophysiology, 26, 807-834.

3. Paillard, J., & Brouchon, M. (1968). Active and passive movements in the calibration of position sense. In S. J. Freedman (Ed.), *The neuropsychology of spatially oriented behavior* (pp. 37-55). Homewood, IL: Dorsey.

Cross References

3.302 Measurement of position sense;

3.314 Perception of elbow angle;

3.318 Perception of finger displacement;

Handbook of perception and human performance, Ch. 13, Sect. 2.2

3.321 Kinesthetic Aftereffects

Key Terms

Apparent limb movement; heaviness; illusory limb movement; kinesthetic aftereffects; limb position; position sense; postural persistence; weight illusion

General Description

Kinesthetic stimulation resulting from maintaining a limb or body part in a fixed position for several seconds, or from contracting the muscles to lift a weight, can produce aftereffects that alter the perceived location of the limb or the apparent heaviness of the weight. For example, when the arm is held briefly extended horizontally to the side, the perceived straight-ahead position of the arm is displaced in the direction of the previously held location (CRef. 3.310). A similar effect occurs if the head is held rotated prior to assessing the perceived straight-ahead position of the head

(CRef. 3.308). This type of phenomenon has been called postural persistence. Another aftereffect produces the weight expectancy illusion (Ref. 3): lifting a heavy weight prior to lifting a lighter one causes underestimation of the lighter weight; conversely, lifting a light weight prior to a heavier one causes overestimation of the heavier weight. A related phenomenon results when upward isometric force is exerted by the arms against an immovable restraint (the Kohnstamm effect); following such an effort, the arms rise almost without the subject's conscious effort (Refs. 2, 4).

Applications

Designs in which operators must maintain limb positions for extended periods or exert force against a fixed restraint or a movable load.

Constraints

- The magnitude of these aftereffects will vary with the magnitude and duration of the inducing conditions.

Key References

1. Craske, B., & Crawshaw, M. (1974). Differential errors of kinesis produced by previous limb positions. *Journal of Motor Behavior*, 6, 273-278.

2. Cratty, B. J., & Duffy, K. E. (1969). Studies of movement aftereffects. *Perceptual and Motor Skills*, 29, 843-860.

*3. de Mendoza, J-L. J. (1979). Demonstration of an aftereffect oc-

curing in the tactile-kinesthetic domain: The gravimetric aftereffect. *Psychological Research*, 40, 415-422.

4. Forbes, A., Baird, P. C., & Hopkins, A. M. (1926). The involuntary contraction following isometric contraction of skeletal

muscle in man. *American Journal of Physiology*, 78, 81-103.

5. Howard, I. P., & Anstis, T. (1974). Muscular and joint-receptor components in postural persistence. *Journal of Experimental Psychology*, 103, 167-170.

Cross References

3.308 Perception of head position;

3.310 Perception of arm position: effect of duration and location of a previously held arm position;

Handbook of perception and human performance, Ch. 13, Sect 2.2

Notes

3.322 Models for the Encoding of Joint Angle

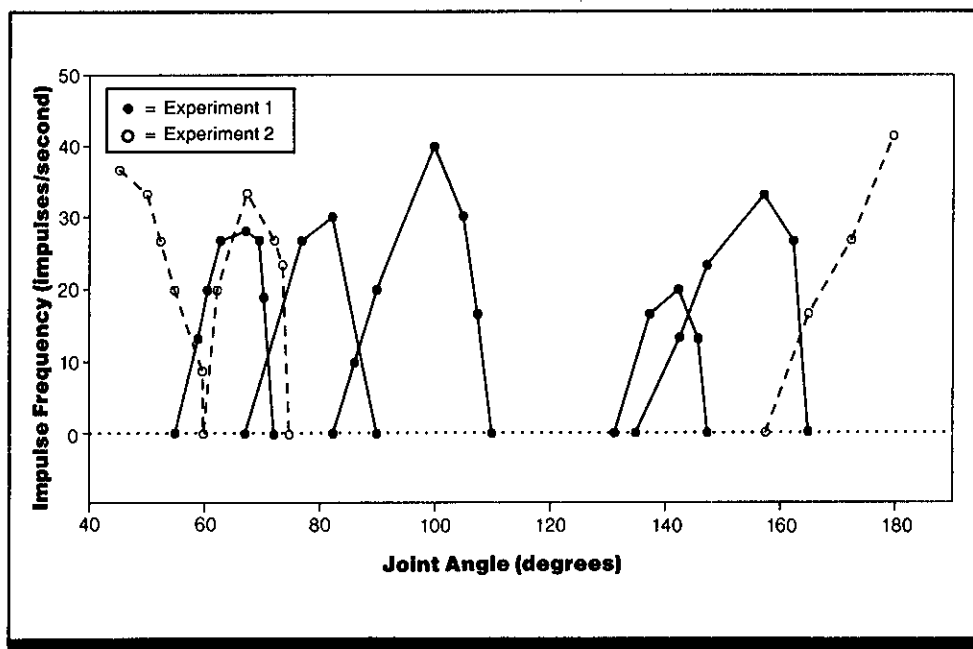

Figure 1. Spatially tuned receptors in the knee joint of the cat. Each curve shows the firing rate of an individual sensory ending as a function of joint angle. Each unit is narrowly tuned, that is, it responds best to a small range of joint angles. Different neural units have different preferred joint angles. (Figure is not representative of the distribution of endings in the range from flexion to extension.) According to the spatially tuned receptor model, joint position is encoded by a population of neural units such as these. One knows joint angle by knowing which neural units of the population are active. (From Ref. 9)

Key Terms

Joint; opponent processing model of position encoding; position sense; spatially tuned receptor model of position encoding

General Description

Two models have been developed for explaining how the static position of joints is encoded in the nervous system. One model, focusing on spatially tuned receptors, is based on the activity of individual neural units, each responsive ("tuned") to only a limited range of joint angles. In this model, each unit responds maximally to a particular joint angle, with responsiveness (frequency of nerve impulses) decreasing rapidly with a change from the optimal joint position. Joint angle is thereby coded by which specific neural units in the population are responding, rather than by the frequency with which they are responding.

The second model, opponent processing, is based on the pattern of activity across the population of neural units. In this model, neural units belong to one of two populations, signaling movements either of flexion or of extension. Movement in one direction will increase the frequency of impulses in the population of units sensitive to that direction while decreasing the impulse frequency in the population of units sensitive to movement in the opposing direction. Joint angle is thus represented by the pattern of activity across all participating units in the population. Both models can be incorporated into a two-stage processing theory, whereby the activity of spatially tuned receptors is integrated into an opponent-processing code at more central levels.

Applications

Processing models can be used to predict sensitivity to movements of joints and discrimination of joint angles.

Empirical Validation

Neurological evidence for the first model (spatially tuned receptors) comes from several studies of the knee joint in the cat (Refs. 1, 2, 9). (See Fig. 1.) These studies show a spatial tuning of ~ 15 -30 deg, with considerable overlap in the response ranges of the individual joint receptors tested. This scheme is similar to the scheme for encoding sound frequency in the cochlea of the inner ear. Evidence for the

second model (opponent processing) comes from the study of thalamic (third-order) neurons in macaque monkeys (Ref. 7). (See Fig. 2.) An opponent-processing mechanism is also found in color vision and is consistent with the activity of muscle groups; nearly every action that shortens some muscles will also lengthen others. Recent work showing that static-position sense derives entirely from receptors in muscle (Ref. 5) favors an opponent-processing scheme; skeletal muscles are always arranged in opponent groups.

Constraints

- Although spatially tuned receptors have been identified in several studies, other research has failed to confirm such results (Refs. 3, 4, 6, 8, 10).

Key References

1. Andrew, F. L., & Dodt, E. (1953). The deployment of sensory nerve endings at the knee joint of the cat. *Acta Physiologica Scandinavica*, 28, 287-296.

2. Boyd, I. A., & Roberts, T. D. M. (1953). Proprioceptive discharges from stretch receptors in the knee-joint of the cat. *Journal of Physiology*, 122, 38-58.

3. Clark, F. J. (1975). Information signaled by sensory fibers in medial articular nerve. *Journal of Neurophysiology*, 38, 1464-1472.

4. Clark, F. J., & Burgess, P. R. (1975). Slowly adapting receptors in cat knee joint: Can they signal joint angle? *Journal of Neurophysiology*, 38, 1448-1463.

5. Clark, F. J., Burgess, R. C., & Chapin, J. W. (1985). The role of intramuscular receptors in the

awareness of limb position. *Journal of Neurophysiology*, 54, 1529-1540.

6. Millar, J. (1975). Flexion-extension sensitivity of elbow joint afferents in cat. *Experimental Brain Research*, 24, 209-214.

*7. Mountcastle, V. B., Poggio, G. F., & Werner, G. (1963). The relation of thalamic cell response to peripheral stimuli varied over an intensive continuum. *Journal of Neurophysiology*, 26, 807-834.

8. Rossi, A., & Grigg, P. (1982). Characteristics of hip joint mechanoreceptors in the cat. *Journal of Neurophysiology*, 47, 1029-1042.

*9. Skoglund, S. (1956). Anatomical and physiological studies of knee joint innervation in the cat. *Acta Physiologica Scandinavica*, 36 (Suppl. 124), 1-101.

10. Tracy, D. J. (1979). Characteristics of wrist joint receptors in the cat. *Experimental Brain Research*, 34, 165-176.

Cross References

- 3.302 Measurement of position sense;
- 3.303 Factors affecting sense of

position and movement of body parts;
Handbook of perception and human performance, Ch. 13, Sect. 3.3

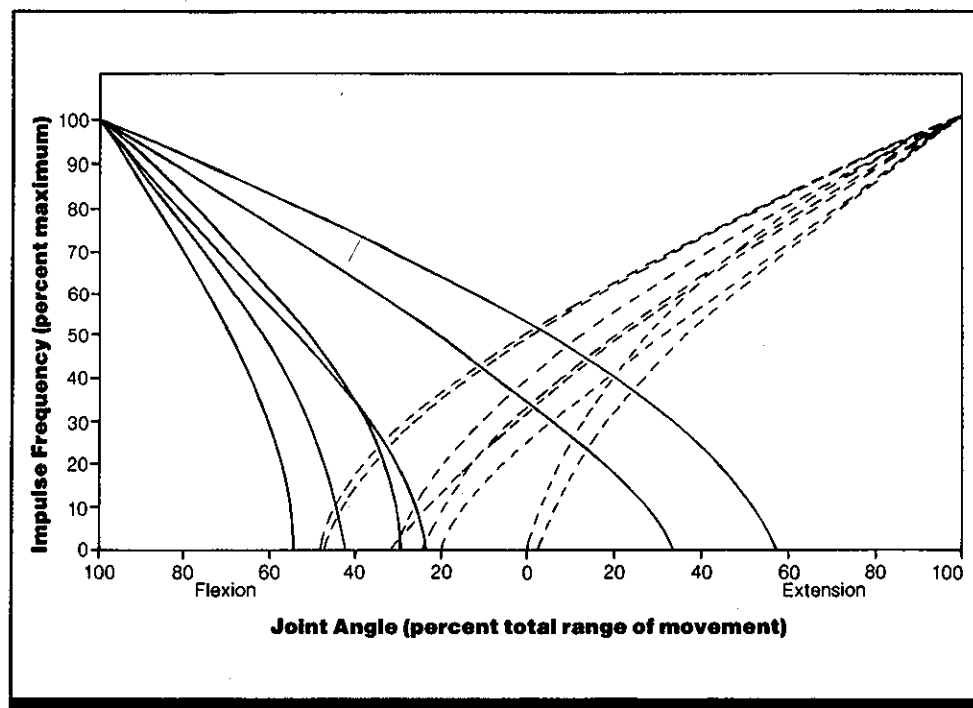

Figure 2. Receptors producing a graded discharge over a large range of joint angles. Each curve shows the relative firing rate of an individual hinge-joint ventro-based thalamic (third-order) neuron of the macaque monkey. Solid curves show neurons which increase firing as the joint moves toward extreme flexion; dotted curves, neurons which increase discharge with increased joint extension. Neither neuron population responds over the entire range of joint angles, but the response profiles of the two groups overlap. According to the opponent process model, joint angle is encoded by the ratio of activity between two neural populations with characteristics such as these. (From Ref. 7)

3.323 Heaviness: Effect of Arm Fatigue

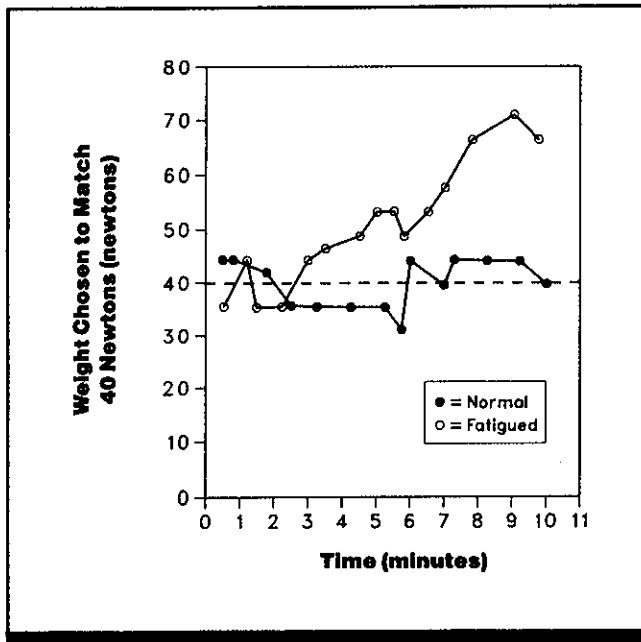

Figure 1. Accuracy of matching weight to the weight supported by a normal and fatigued reference arm as a function of time supporting reference weight. Reference weight was supported continuously by reference arm for fatigue condition; reference arm rested between trials for normal condition. (From Ref. 3)

Key Terms

Arm fatigue; heaviness; muscle fatigue; muscle sense; weight perception

General Description

When one arm estimates the heaviness of weights supported by the other arm, the perceived weight increases as the duration of muscle contraction (and fatigue) in the reference arm increases.

Methods

Test Conditions

- Both elbows rested on a table top at right angles
- Each wrist supported weights in a bucket coupled to wrist by rope-and-pulley arrangement; reference arm loaded with 4.09-kg (40-N) weight; comparison arm loaded

with weights in increments of 0.45-1.36 kg until subjective match was produced

- Normal conditions: weight judgments made immediately following flexion of reference arm, reference arm rested between trials; fatigue condition: reference arm supported weight continuously by muscle

contraction for up to 10 min and weight judgments made at various intervals during this period

- No visual feedback present

Experimental Procedure

- Method of limits
- Independent variable: duration of arm flexion
- Dependent variable: apparent

heaviness of reference weight as measured by matched weight chosen with comparison arm

- Subject's task: indicate if comparison weight is same or different from reference weight and achieve a perceived match by asking experimenter to add or remove weight from comparison arm
- 9 subjects

Experimental Results

- The judged heaviness of a weight increases as it is supported for longer periods of time by a flexed arm.
- When the reference arm is rested, the heaviness of the support weight is estimated fairly accurately.

Variability

Although the data presented in Fig. 1 are from a single subject, the results are similar to those obtained for 8 other subjects.

Repeatability/Comparison with Other Studies

Similar results are obtained when factors other than fatigue induce muscle weakness (Refs. 1, 2).

Key References

1. Gandevia, S. C. (1982). The perception of motor commands or effort during muscular paralysis. *Brain*, 105, 151-159.

2. Gandevia, S. C., & McCloskey, D. I. (1977). Changes in motor commands, as shown by changes in perceived heaviness, during partial curarization and peripheral anaesthesia in man. *Journal of Physiology*, 272, 673-689.

*3. McCloskey, D. I., Ebeling, P., & Goodwin, G. M. (1974). Estimation of weights and tensions and apparent involvement of a "sense of effort." *Experimental Neurology*, 42, 220-232.

4. Roland, P. E., & Ladegaard-Pedersen, H. (1977). A quantitative analysis of sensations of tension and of kinesthesia in man. Evidence for a peripherally originating muscle sense and for a sense of effort. *Brain*, 100, 671-692.

Cross References

3.324 Heaviness: effects of anesthesia or electrocutaneous stimulation of the fingers;

Handbook of perception and human performance, Ch. 13, Sect. 2.3

3.324 Heaviness: Effects of Anesthesia or Electrocutaneous Stimulation of the Fingers

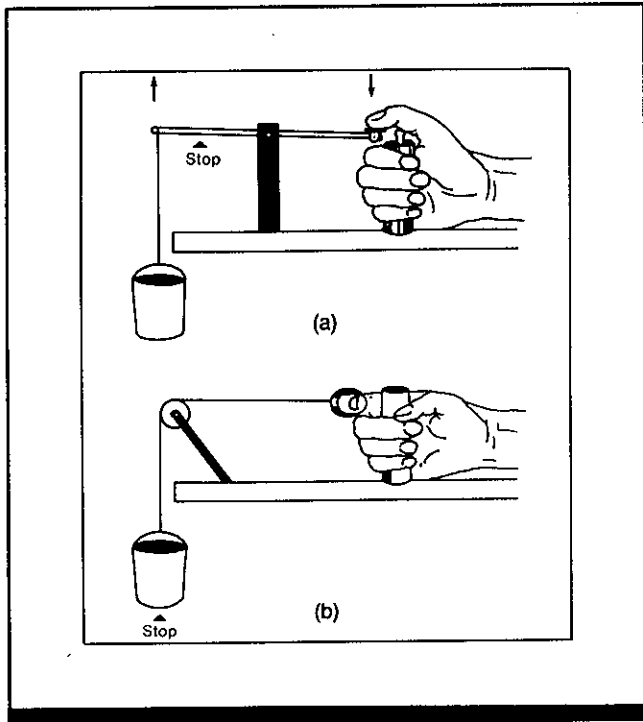

Figure 1. Apparatus and position of right hand in weight-matching task. (a) Flexing the terminal joint of the thumb depressed one end of "see-saw" and lifted the weight. (b) Flexing the index finger, predominantly at the proximal interphalangeal (middle) joint, lifted the weight over the pulley. For all modes of lifting, the left hand used a similar apparatus. (From Ref. 1)

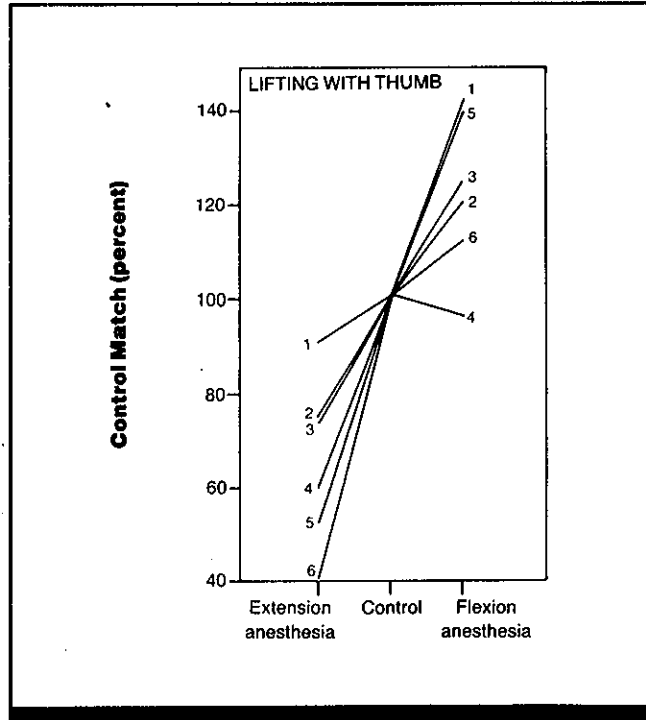

Figure 2. Accuracy in estimating weight of 1 kg lifted by thumb flexion and 0.5 kg lifted by thumb extension with anesthesia of the thumb. Estimates are given in percentages of control matches (weight estimates with no anesthesia). Results for individual subjects are indicated by numerals on the right and left edges of the figure. (From Ref. 1)

Key Terms

Electrocutaneous stimulation; heaviness; muscle sense; skin anesthesia; weight perception

General Description

Perceived heaviness of weights lifted with the thumb or index finger is affected by sensory inputs from the skin: anesthesia of the skin will increase perceived heaviness of weights lifted by flexing the digit; electrical stimulation of

the skin will decrease the perceived heaviness. The effect of anesthesia depends on whether lifting is done by flexion or extension movements; during anesthesia, weights lifted by extending the thumb feel lighter than normal.

Methods

Test Conditions

- Thumb or index finger of left hand lifted a weight by flexion or extension of the digit
- For the thumb, finger held on upright rod while thumb rested on a lever from which a weight (1 kg for flexion; 500 gm for extension) was suspended in a 100-gm bucket
- For the index finger, the distal interphalangeal joint (terminal

joint) was placed in a ring to which a pulley was attached that suspended a 2-kg weight in bucket

- For both conditions, right hand operated corresponding apparatus to manipulate adjustable comparison weights
- For some conditions, the thumb, index finger, or little finger of left hand was anesthetized with 2% lignocaine (anesthesia judged by loss of touch, pressure, and pain) or stimulated by a 60-Hz electrical

pulse delivered through surface electrodes

- No visual feedback was presented

Experimental Procedure

- Method of limits
- Independent variables: digit used to lift weights, digit receiving treatment, treatment condition (stimulation or anesthesia)
- Dependent variable: perceived heaviness, expressed as the ratio of

matched weight during anesthesia or stimulation to matched weight in the absence of stimulation or anesthesia (control)

- Subject's task: indicate if weight supported by left hand was equal to weight supported by right hand, and guide experimenter in increasing or decreasing weight until a match was achieved
- 10 trials per condition
- 6 subjects

Experimental Results

- The perceived heaviness of a weight lifted by thumb flexion increases if the thumb or index finger is anesthetized ($p < 0.025$), and decreases if the index finger receives electrical stimulation ($p < 0.05$), but is unaffected by anesthesia or electrical stimulation of the little finger.
- During anesthesia of the thumb, weight lifted by extension of the thumb feels lighter than normal ($p < 0.005$).
- Perceived heaviness of a weight lifted by flexion of the index finger decreases with electrical stimulation of the

thumb ($p < 0.001$) and increases with anesthesia of the thumb ($p < 0.001$).

Variability

Significance was determined with paired t tests.

Repeatability/Comparison with Other Studies

Fatiguing of the arm muscles leads to an increase in perceived heaviness of weight supported by the arm (Ref. 2, CRef. 3.323).

Constraints

- These effects of electrical stimulation or anesthesia are seen with the thumb only if the muscles that move the thumb do the lifting and not if the muscles of the arm and shoulder do the lifting (using the thumb muscle only to hold the thumb rigid to support the weight).

Key References

*1. Gandevia, S. C., & McCloskey, D. I. (1977). Effects of related sensory inputs on motor performances in man studied through changes in perceived heaviness. *Journal of Physiology*, 272, 653-672.

2. McCloskey, D. I., Ebeling, P., & Goodwin, G. M. (1974). Estimation of weights and tensions and apparent involvement of a "sense of effort." *Experimental Neurology*, 42, 220-232.

Cross References

3.323 Heaviness: effect of arm fatigue;

Handbook of perception and human performance, Ch. 13, Sect. 2.3

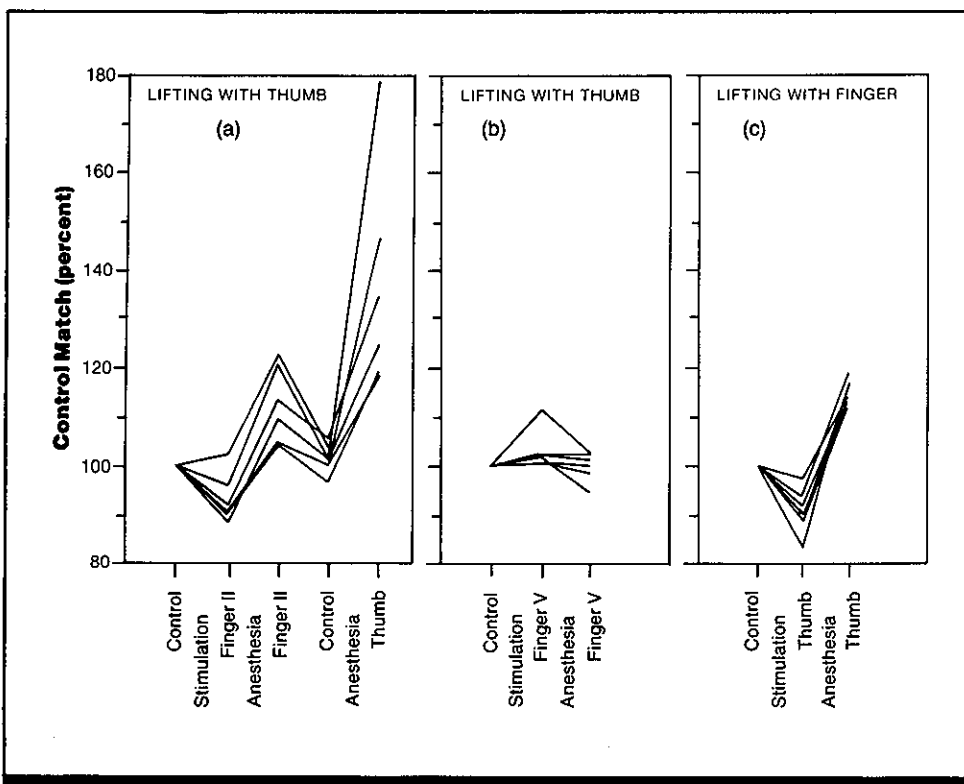

Figure 3. Accuracy of weight-matching with electrical stimulation and anesthesia of the digits. Results are expressed as a percentage of control matches (estimates without electrical stimulation or anesthesia). Results are shown for 6 subjects. (a) Accuracy of matching 1-kg weight lifted by thumb flexion when sensory input from index finger (finger II) is increased by electrical stimulation and removed by anesthesia, and when thumb is anesthetized. (b) Accuracy of matching 1-kg weight lifted by thumb flexion when input from little finger (finger V) is enhanced by electrical stimulation and decreased by anesthesia. (c) Accuracy of matching 2-kg weight lifted by flexion of index finger when input from thumb is increased by electrical stimulation and removed by anesthesia. (From Ref. 1)

3.325 Perception of Effort and Force: Effect of Muscle Vibration and Anesthesia

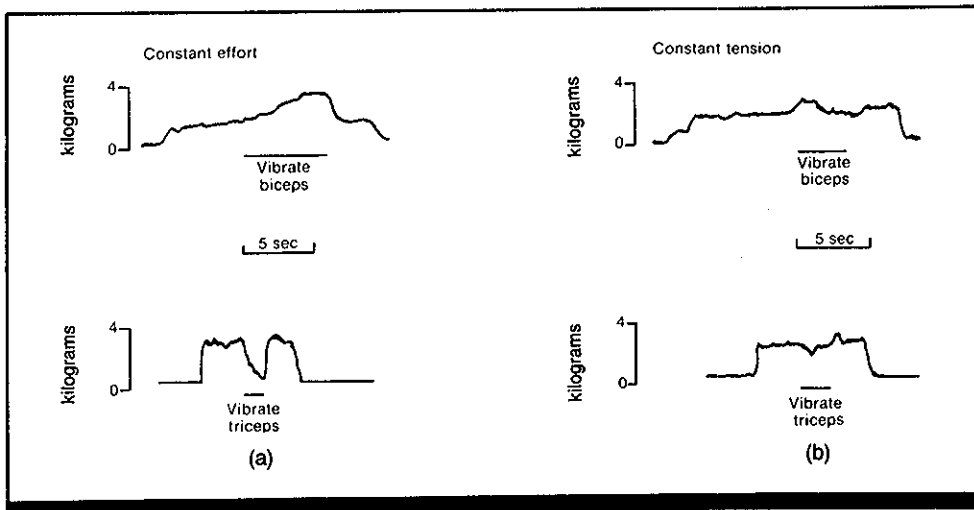

Figure 1. Accuracy in maintaining constant effort or constant tension with vibration of arm muscles. Subject applied force to strain gauge by flexing arm. Vibration was applied either to biceps or to triceps muscle of arm; wrist and tip of supporting elbow anesthetized. Tracings show tension achieved as a function of time for one subject. Subject asked to: (a) maintain a constant effort in pulling against the strain gauge; or (b) maintain a constant tension on the strain-gauge cable. (From Ref. 1)

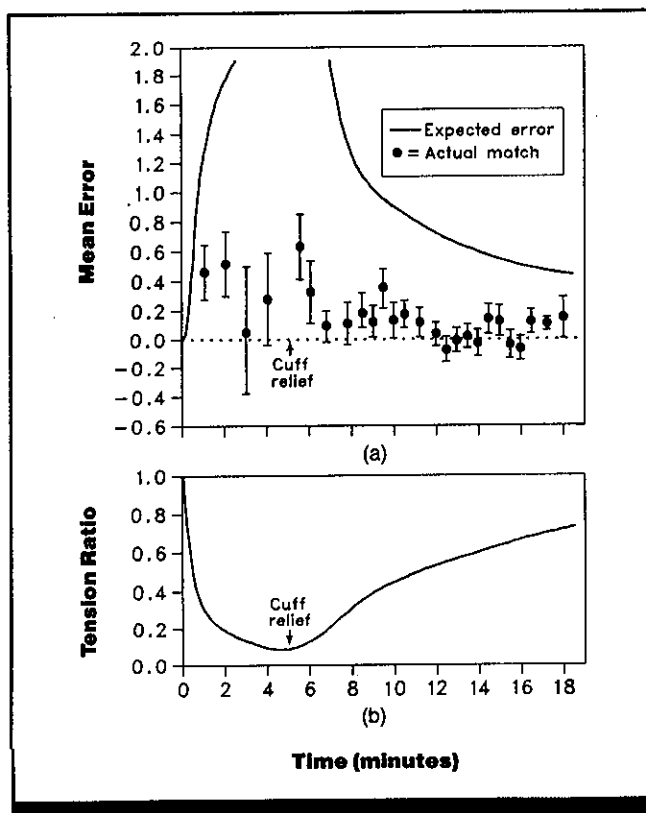

Figure 2. Effects of muscle weakening on judgment of force. Subject squeezed strain gauge between thumb and index finger of left hand. Skin and joints of hands anesthetized and muscles partially paralyzed by gallamine blockade to forearm. (a) Accuracy in matching, with normal hand, a reference force exerted by weakened hand. Matching error is calculated as the logarithm of the ratio of the reference force to the matching force. Expected error estimated by measuring maximum force produced before paralysis and at different times after paralyzing injection (see text). Panel shows mean error and standard error of the means for 11 subjects. (b) Time course of recovery from muscle paralysis, expressed as the fraction of the normal maximal force of compression that could be exerted with the thumb and index finger. Arrows indicate release of tourniquet restricting blood flow to treated arm. (From Ref. 2)

Key Terms

Muscle effort; muscle paralysis; muscle sense; muscle tension; muscle vibration; muscle weakness; skin anesthesia

General Description

During isometric contraction of the arm muscles, muscle vibration induces considerable error in maintaining a constant level of effort in pulling against a strain gauge, but does not affect error in maintaining constant tension on the

strain-gauge cable. Weakening (partial paralysis) of the muscles by administering a muscle-relaxing drug reduces subjects' ability to match apparent force exerted by the weakened hand in isometric compression of a strain gauge, but has little effect on the ability to match apparent effort exerted.

Methods

Test Conditions

Muscle vibration (Ref. 1)

- Hand was anesthetized to eliminate skin cues by inflating a pressure cuff around wrist, and, in some subjects, the skin over the tip of elbow was anesthetized by injecting a local anesthetic (type not specified); after anesthesia was confirmed, wrist and arm pulled against a strain gauge cable with a force between 1 and 5 kg while subject attempted to maintain (for 5-10 sec) a perceptually constant effort (not further defined for subjects) or force (tension in strain gauge cable); meanwhile, a 100-Hz vibration was applied to tendon of either biceps or triceps muscle
- Subjects blindfolded throughout procedure

Muscle weakening (Ref. 2)

- Circulation in left arm was occluded by a tourniquet and thus isolated; muscles in arm were then weakened by intravenous injection with muscle relaxant drug (gallamine triethiodide, 16 mg in 20 ml saline); drug does not affect sensation; skin and joints of both hands anesthetized with 2% lignocaine (to eliminate skin and joint cues); strain gauge pressed between

thumb and index finger of weakened hand to some level of force set by experimenter (reference force), then subject matched the apparent force or apparent effort with the other (normal) hand; measurements made over 18-min period after releasing tourniquet while muscles recovered

Experimental Procedure

Muscle vibration

- Method of adjustment
- Independent variables: muscle vibrated (biceps or triceps), type of judgment (instructions to maintain constant effort or constant tension)
- Dependent variable: tension (in kg) maintained
- Subject's task: maintain either a constant effort or constant tension on strain gauge cable
- 12 subjects

Muscle weakening

- Method of adjustment
- Independent variables: degree of paralysis as measured by duration of induction and recovery periods; type of judgment (instructions to match force achieved or effort exerted)
- Dependent variable: matching error expressed as the natural log of

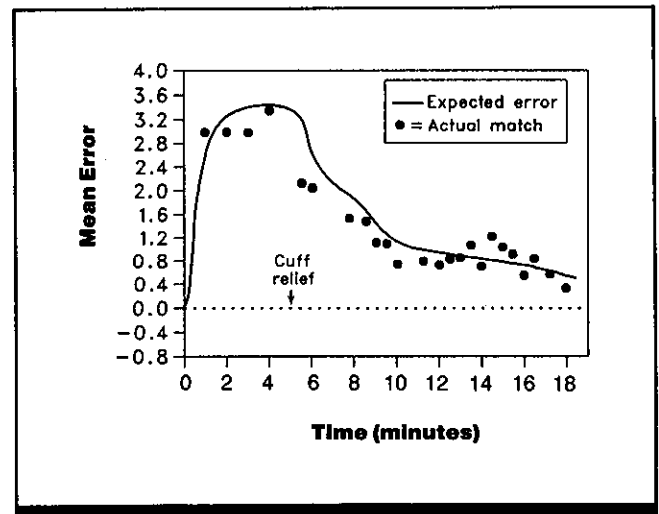

Figure 3. Effect of muscle weakening on judgments of effort. Shown is the accuracy of one subject in matching with normal hand and the apparent effort exerted by partially paralyzed hand in isometric compression of a strain gauge. Matching error and expected error calculated as in Fig. 2. (From Ref. 2)

the ratio of the matched force to the reference force

- Subject's task: match with normal hand degree of force achieved

or effort exerted by weakened hand in compressing strain gauge

- 12 subjects for force matching, 4 subjects for effort matching

Experimental Results

- Subjects' ability to exert a perceptually constant effort while pulling against a strain gauge by flexing the arm (eyes covered) is impaired by vibration of either the biceps muscle (which assists contraction) or the triceps muscle (which reflexively opposes contraction). When subjects are asked to maintain constant tension on the strain gauge cable, however, exerted force remains fairly constant regardless of muscle vibration (Fig. 1).
- Weakening the muscles of the hand by injection of a muscle relaxant significantly reduces the ability of blindfolded subjects to accurately match the force exerted by the weakened hand in squeezing a strain gauge, but not in their ability to match the apparent effort exerted in squeezing the gauge (Figs. 2 and 3).
- Expected error (solid curves in Figs. 2 and 3) for force- and effort-matching is calculated as the log of the ratio of

maximum force of the arm before gallamine injection to maximum force at the specified time after injection, based on the assumption that subjects relied on a "sense of effort" (outgoing motor nerve impulses to the muscles) in making their matches. While this assumption appears justified for matching of perceived effort (actual matching errors are close to those predicted), errors for force-matching are far below the expected errors, suggesting that force-matching relies on sensory information about muscle tension and body movement from receptors in the muscles and tendons.

Variability

Although Fig. 1 reports data from only 1 subject, the findings are typical of the subjects tested. Error bars in Fig. 2 represent ~ 1 standard error of the mean. Although no error bars are shown for Fig. 3, variability of subjects in matching effort was comparable to variability for force matches (Fig. 2).

Constraints

- Muscle fatigue may also be expected to affect judgments of effort.

Key References

*1. McCloskey, D. I., Ebeling, P., & Goodwin, G. M. (1974). Estimation of weights and tensions and

apparent involvement of a "sense of effort." *Experimental Neurology*, 42, 220-232.

*2. Roland, P. E., & Ladegaard-

Pedersen, H. (1977). A quantitative analysis of sensations of tension and of kinesthesia in man. *Brain*, 100, 671-692.

Cross References

3.323 Heaviness: effect of arm fatigue;

3.324 Heaviness: effects of anes-

thesia or electrocutaneous stimulation of the fingers;

Handbook of perception and human performance, Ch. 13, Sect. 2.3

3.326 Tonic Neck Reflex: Influence on Weight Lifting

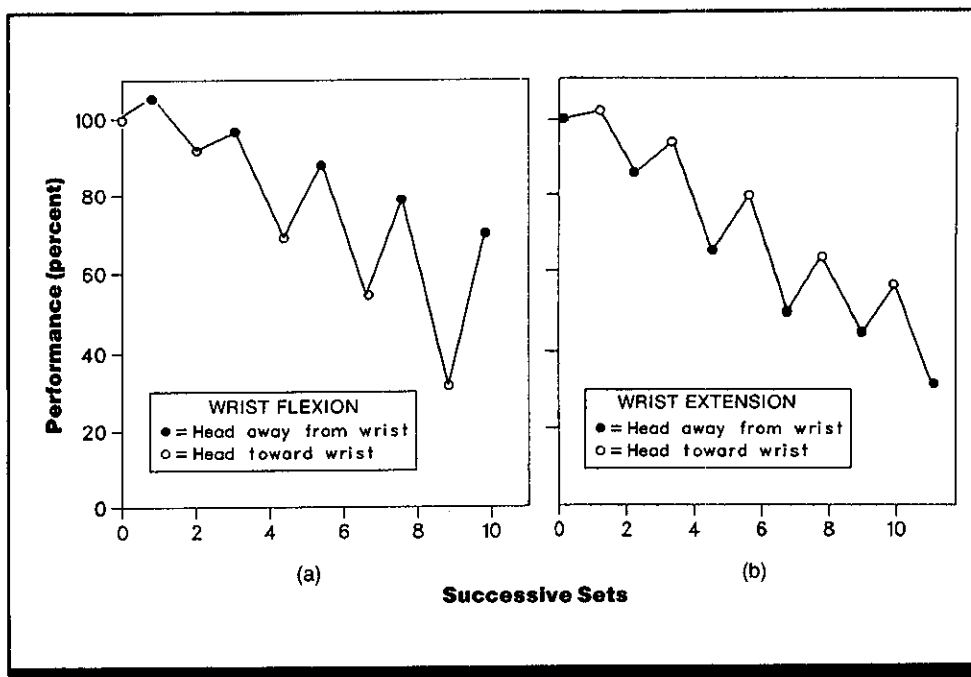

Figure 1. Effect of head position on weight lifting performance with one wrist by either (a) flexion or (b) extension. Data are for one well-trained (normal) subject. (From Ref. 1).

Key Terms

Synergy; tonic neck reflex; weight lifting

General Description

Synergies are innate elementary motor patterns in which stereotyped coordinations of more than one muscle group occur in different settings or activities. Tonic neck reflexes are synergies elicited by head position. In a tonic neck reflex, when the head is turned or tilted to one side the arm and leg on the same side are extended and the arm and leg on the opposite side are flexed; all limbs extend when the neck is bent forward.

Tonic neck reflexes improve performance when the required action and the position of the head are in accord with a tonic neck reflex. For weight lifting with a single wrist, lifting by wrist extension is improved by looking toward the wrist, while lifting by wrist flexion is improved by looking away from the wrist. Lifting by flexion with both wrists is improved by tilting the head forward; tilting the head back facilitates lifting by extension of both wrists. The facilitation of performance is strong enough to overcome the effects of fatigue.

Methods

Test Conditions

- Exercises involving weight lifting with one or two wrists, with front-to-back movements of the wrist joint in rhythm with a metronome (speed unknown); usually sets (bouts) of 25 contractions alternated with rest periods of the same duration; exercises performed on Hellebrandt-Kelso modification

of the Mosso ergograph

- Ergographic, photographic, and electromyographic data obtained simultaneously; enlarged photographs reproduced as line drawings for anatomic-physiological analysis; electromyographic comparisons limited to single sessions within subjects to decrease variability due to electrode placement
- Stress introduced by increasing resistance systematically with each bout until load could no longer be

lifted, or overloading subject at beginning of exercise and continuing to exhaustion

Experimental Procedure

- Independent variables: number of wrists used, type of wrist movement (flexion or extension), position of head (determined from photographs), degree of stress (measured by electromyograph)
- Dependent variable: work output

(measured by ergograph)

- Subject's task: flex or extend one or two wrists against resistance while holding head in preferred or opposite position
- For motivation, used intragroup competition and pitted daily performance against previous performance
- 9 male and 9 female adults, including novices and well-trained subjects; 4 subjects had cerebral palsy

Experimental Results

- Head position spontaneously selected by subject for each exercise is always consistent with pattern of tonic neck reflex and thus facilitates performance.
- Rotating head toward wrist facilitates lifting by wrist extension for one-wrist exercises; rotating head away from wrist facilitates lifting by flexion.
- Tilting head forward facilitates lifting by flexion with two wrists.

Key References

*1. Hellebrandt, F. A., Houtz, S. J., Partridge, M. J., & Walters, C. E. (1956). Tonic neck reflexes in exercises of stress in man. *American Journal of Physical Medicine*, 35, 144-159.

Cross References

9.202 One- versus two-handed reaching: effects of target distance and width;

9.305 Coordination of hand movements on timed tasks;

Handbook of perception and human performance, Ch. 30, Sect. 5.3

- Tilting head back inhibits lifting by flexion of two wrists and facilitates lifting by extension of two wrists.
- All effects become greater as fatigue increases.

Variability

No information on variability was given.

Repeatability/Comparison with Other Studies

Work output is facilitated by tonic neck reflexes.

Notes



The following page(s) provide higher quality versions of graphics contained in the preceding article or section.

1.706 Descriptive Attributes of Color Appearance

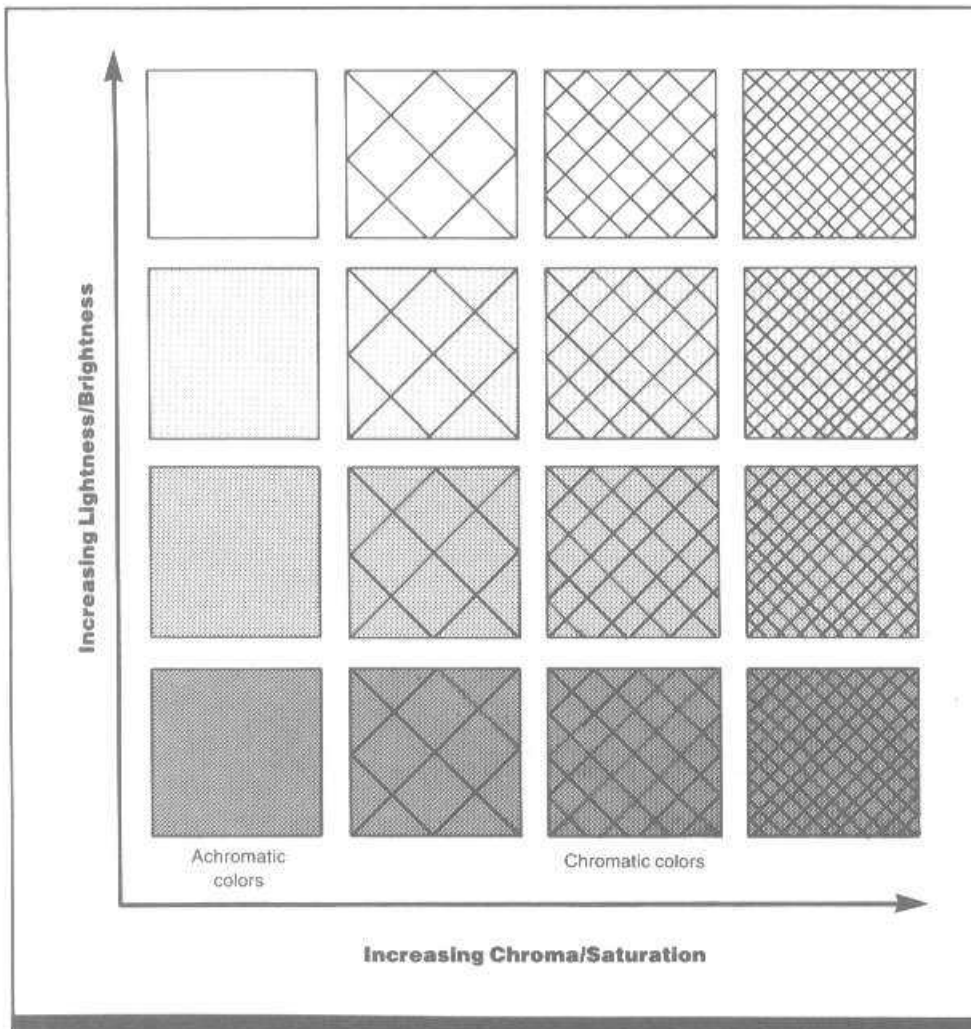

Figure 1. Variation of lightness and chroma for a constant-hue color. In this black and white simulation, the grid pattern inside the squares represents a given chromatic color (e.g., blue). The less detailed grid simulates a color with low chroma or saturation (such as pale sky blue). The more detailed grid represents the same color hue, but with high chroma or saturation (such as rich royal blue). The amount of achromatic color (varying from black through gray to white) mixed with the hue determines the degree of lightness or brightness for a given color chip (i.e., the chip with the lowest brightness and highest chroma might be dark navy blue).

Key Terms

Brightness; chroma; color appearance; color description; colorimetric purity; hue; lightness; luminance; saturation; tint; wavelength

General Description

Color is the aspect of visual perception that allows an observer to distinguish between otherwise identical objects, surfaces, or areas on the basis of different spectral compositions of radiant energy (wavelengths and wave amplitudes) emitted or reflected from them. *Color appearance* usually is described in terms of three basic color attributes:

Hue: the perceived color, which can be given a name such as red, yellow, blue-green, or purple. The four unique hues are those which cannot be further described using hue names other than their own: red, green, yellow, and blue. Binary or non-unique hues can be described by combining other hue names, such as reddish-yellow (orange) or bluish-red (violet). *Chromatic* colors possess hue; *achromatic*

colors are color stimuli devoid of hue, such as white, gray, or black.

Brightness or lightness: *brightness* refers to the degree of stimulus intensity or the level of light an area appears to emit, ranging from dazzling (very bright) to dim or very dark (often used as descriptive adjectives for the hues). *Lightness* usually refers to the reflectivity of a surface; that is, the amount of light the object or surface appears to emit in comparison with that emitted by a surface perceived as "white." Thus, lightness can be considered *relative brightness*. Lightness ranges from very light (white) to very dark (black).

Chroma or saturation: the degree of color purity or richness (apparent deviation from white). *Chroma* is the per-

1.713 Brightness Induction

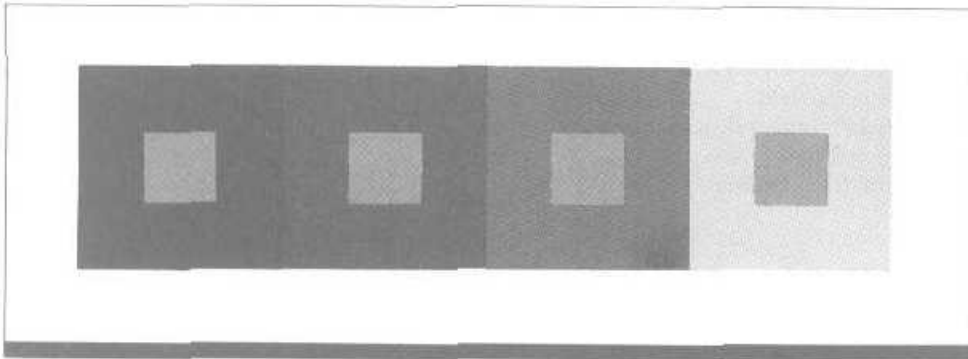

Figure 1. Example of lightness induction. All of the small squares have the same reflectance, but appear to have different lightnesses because they lie on backgrounds of different reflectances. (From *Visual perception* by T. N. Cornsweet, Copyright © 1970 by Academic Press. Reproduced by permission of Harcourt Brace Jovanovich, Inc.)

Key Terms

Achromatic induction; brightness; brightness induction; color appearance; lightness; lightness induction; luminance; simultaneous brightness contrast; spatial contrast

General Description

An area or object of fixed **luminance** or **reflectance** appears to increase or decrease in **lightness** or **brightness** when the luminance or reflectance of the area surrounding it is decreased or increased. This effect is called either *lightness* or *brightness induction*, depending on whether the target appears to reflect or emit light, respectively.

An example of lightness induction is shown in Fig. 1. The four small squares (test fields) have identical reflectances, yet their lightnesses appear different due to differences in the reflectances of the four backgrounds (inducing fields).

Figure 2 shows the results of an experiment in which the luminance of the test field is held constant while the luminance of the inducing field is gradually increased, and the observer adjusts the luminance of a separate matching field so that its lightness matches that of the test field. As the luminance of the inducing field is increased, starting from a very low level that appears black (i.e., luminance thresh-

old), the lightness of the test field increases. (Increases in the luminance of the test field from zero to threshold will obviously produce no induction because these changes will not be visible.) Eventually, though, this trend reverses and, once the inducing field's luminance reaches approximately half that of the test field, the test field regains its original lightness. As the luminance of the inducing field increases still further beyond this point, the lightness of the test field diminishes very rapidly and it soon appears black. Figure 2 is representative of data that have been collected for test fields having luminances ranging from approximately 0.1 to 113 cd/m². In cases such as those described above, where lightness induction causes the differences in the lightnesses of the test and background fields to increase, the effect is usually called *lightness contrast*. In other cases, induction leads to a decrease in lightness differences. This effect is called *reverse contrast*, *assimilation*, or *equalization*.

Lightness induction is influenced by a number of factors as summarized in Table 1.

Applications

Selection and specification of reflectance, luminance, and illumination levels for areas and objects and for their backgrounds, when constancy of brightness or lightness is desired (as in lighting, painting, or otherwise treating a surface when brightness homogeneity may be important) or when specific differences in brightness or lightness are necessary (as for brightness coding in visual displays).

1.714 Simultaneous Lightness Contrast: Effect of Perceptual Organization

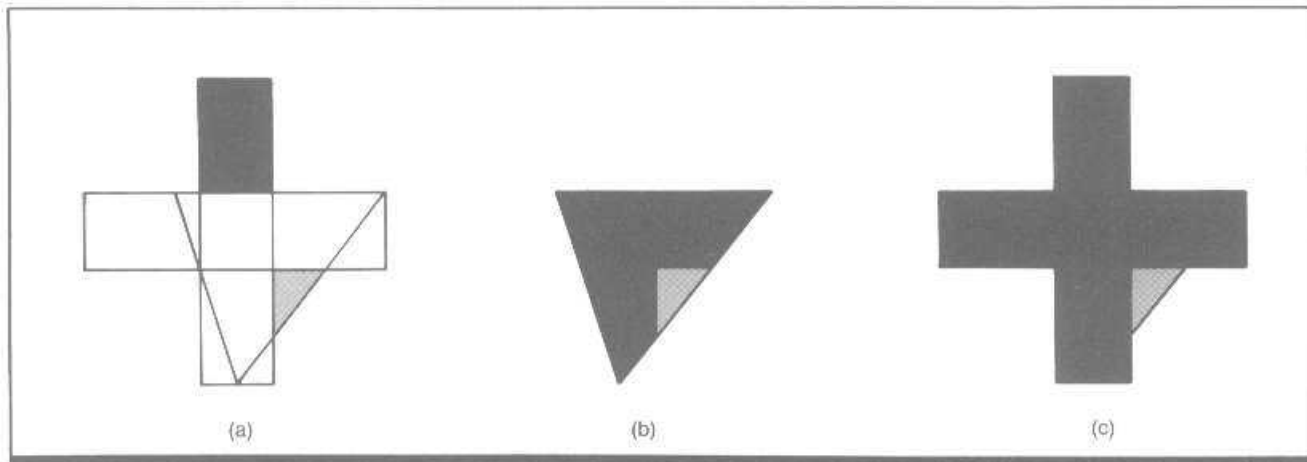

Figure 1. The Benary effect. The gray triangle on the larger black triangle (b) appears lighter than the one next to the black cross (c) despite the fact that the former is surrounded by less black than the latter. The drawing in (a) shows how the central figure is constructed from the cross. The “belongingness” of one gray triangle to the black triangle leads to greater contrast than the mere adjacency of the other gray triangle to the cross. (From Ref. 1)

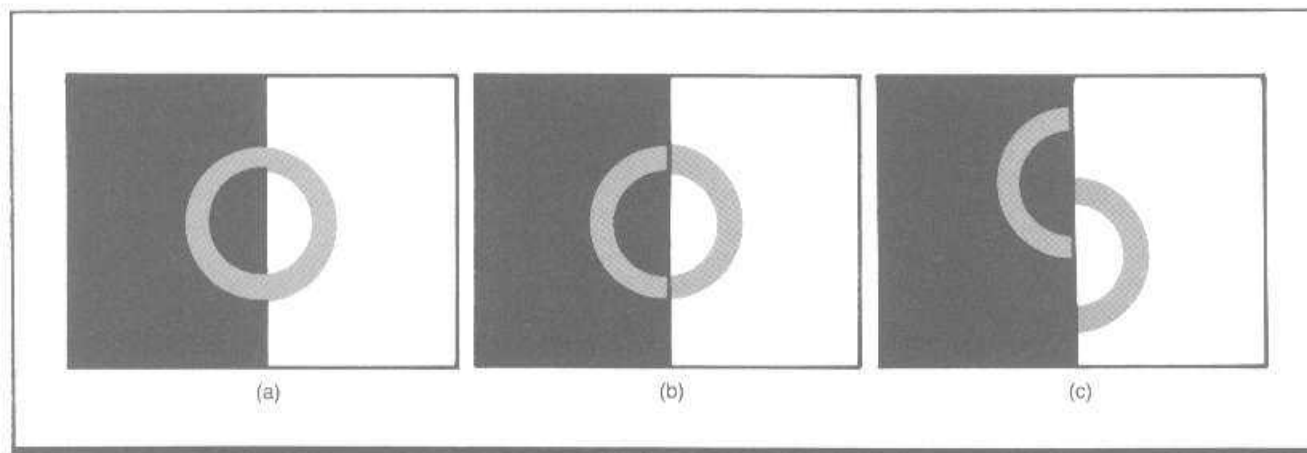

Figure 2. The Koffka-Benussi ring. (a) Each half of the gray ring should undergo contrast with the differing background reflectance values and thus appear different in lightness. That this does not occur suggests that the perceived unity of the ring opposes contrast. When thin vertical lines are placed on top of the central region of the ring (b) or the two halves of the ring are shifted (c), the contrast effect occurs. (From Ref. 6)

Key Terms

Lightness; lightness induction; perceptual organization; simultaneous brightness contrast

General Description

The *lightness* of an object or surface (its whiteness, grayness, or blackness) correlates primarily with its reflectance, i.e., the amount of incident illumination reflected from its surface. However, lightness is also influenced by the surroundings in which the object is viewed. For example, a gray square of given reflectance will appear lighter when it is viewed against a black background than when it is viewed

against a white background. This effect is an example of *lightness induction* and is known as *simultaneous lightness contrast* (CRef. 1.713).

The lightness of surfaces is also affected by the organization of the visual information. Surfaces which are perceived to belong together exhibit more lightness contrast than surfaces which are not perceived to belong together. For example, in Figs. 1b and 1c, the gray triangles have

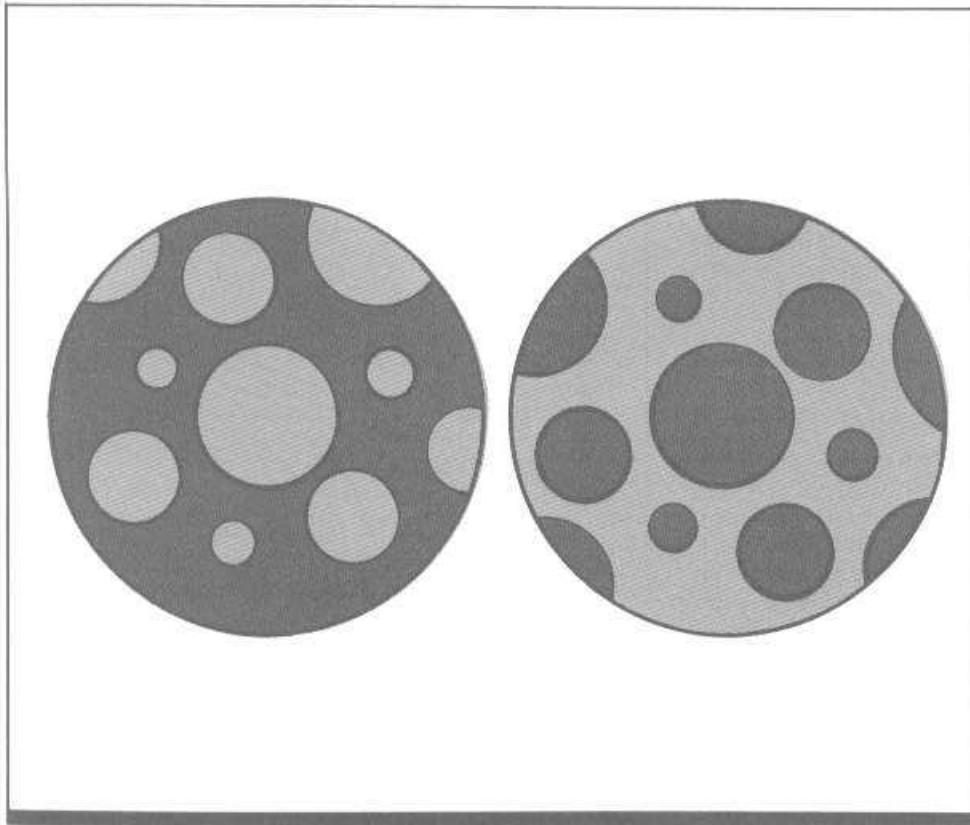

Figure 3. Differential contrast of figure and ground. Although the light gray regions in both circles are equal in area and lightness value, those perceived as figures (left) appear lighter than the region seen as ground (right). A similar effect occurs for the dark gray regions; those appearing as figures on the right appear darker than the ground on the left. (From Ref. 4)

equal reflectances and are bounded for equal extents by black; however, the gray triangle next to the cross shows less lightness contrast (appears darker) than the gray triangle that is perceived as part of a larger black triangle.

Effects of lightness contrast extend throughout a surface and are limited to the perceived surface (Fig. 2). The gray ring is unaffected by conflicting contrast information until it is broken into two half rings, each of which exhibits the expected lightness contrast effects (Ref. 5).

A surface perceived as figure contrasts with the background more than the background contrasts with the figure (Fig. 3, Ref. 4). For two lighter gray surfaces of equal re-

flectance intermixed with darker gray surfaces, the lighter gray figure appears lighter than the lighter gray background.

A surface does not exhibit lightness contrast with retinally adjacent surfaces if the surface is not coplanar with the background surface (i.e., if it is at a different distance than the background) (Ref. 3). In general, spatial position is as important in lightness contrast as are illumination and reflectance; this is consistent with the role played by the spatial position of a light source in determining illumination in real world scenes.

Applications

Selection and specification of reflectance, luminance, and illumination levels for areas and objects and for their backgrounds, when constancy of lightness is desired (as in light-

ing, painting, or otherwise treating a surface on which brightness homogeneity may be important) or when specific differences in lightness are necessary (as for lightness coding in visual displays).

Key References

1. Benary, W. (1924). Beobachtung zu einem Experiment über Helligkeitskontrast. *Psychologische Forschung*, 4, 131.
2. Cornsweet, T. N. (1970). *Visual perception*. New York: Academic Press.

3. Gilchrist, A. (1980). When does perceived lightness depend on perceived spatial arrangement? *Perception & Psychophysics*, 28, 527-538.
4. Metzger, W. (1953). *Gesetze des*

Sehens. Frankfurt, W. Germany: Waldemar Kramer.

5. Rock, I. (1983). *The logic of perception*. Cambridge, MA: MIT Press.

6. Rock, I. (1986). The description and analysis of object and event

perception. In K. R. Boff, L. Kaufman, & J. P. Thomas (Eds.), *Handbook of perception and human performance: Vol. II. Cognitive processes and performance*. New York: Wiley.

Cross References

- 1.712 Brightness constancy;
- 1.713 Brightness induction;
- 1.715 Model of brightness contrast

1.716 Mach Bands

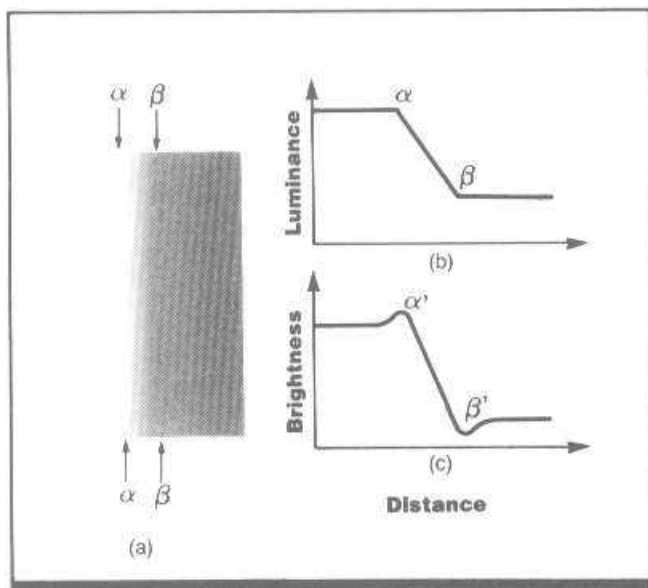

Figure 1. In pattern (a) the luminance is constant in the vertical direction and varies horizontally according to diagram (b). A bright Mach band appears at α and a dark band at β , so that the subjective brightness varies approximately as shown in (c). (From Ref. 3)

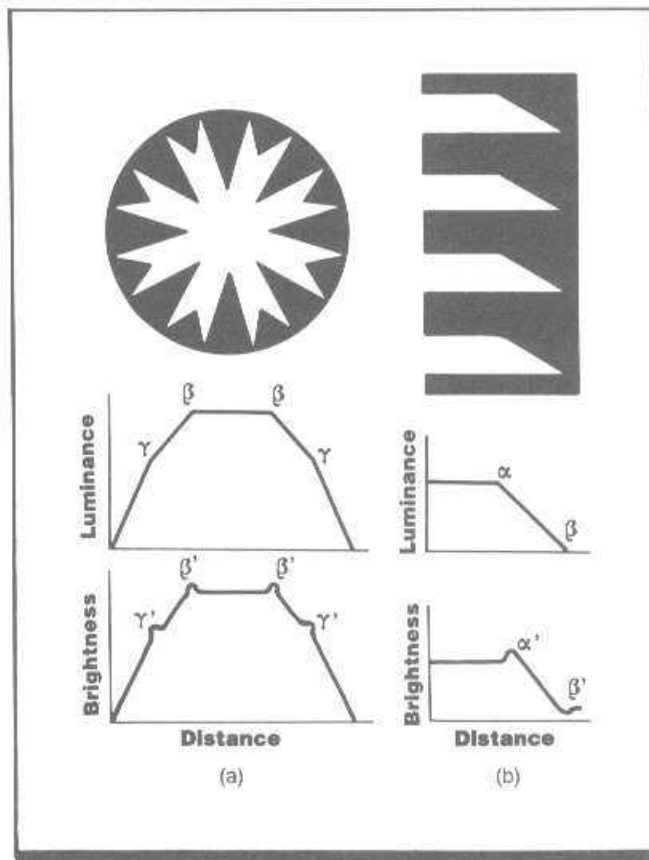

Figure 2. Patterns used with rotating discs (a) or cylinders (b) to produce Mach bands. The Mach bands are perceived at points where the luminance curves bend [points β' and γ' of the disc diameter in (a) and points α' and β' of the direction parallel to the axis of rotation of the cylinder in (b)]. (From Ref. 3)

Key Terms

Achromatic induction; border effects; color appearance; Mach bands; simultaneous color contrast

General Description

Mach bands are bright or dark bands that appear near a boundary between adjacent, illuminated light and dark regions in a visual field. Because the bright band is in the light region and the dark band is in the dark region (Fig. 1), the phenomenon functions as an edge enhancement. The effect occurs even though the physical distribution of light shows no changes in luminance that correspond to changes in perceived brightness.

Figure 2 shows the distribution of luminance and the perceived brightness for two patterns that generate Mach bands when they are rotated at an appropriate speed. The effect is influenced by several variables:

- Width of the bright band decreases if either the highest luminance or the steepness of the luminance gradient from α to β (i.e., the slope from dark to light) increases. The

dark band at β' (in the brightness plot in Fig. 2b) seems to be less dependent on the steepness of the gradient.

- Difference in brightness between the Mach bands and the adjacent areas increases as the angular width of the area from α to β decreases for patterns containing a linear gradient (e.g., the pattern in Fig. 2b).
- The threshold for perception of Mach bands depends on exposure duration. The bands are seen with stimulus durations as brief as 1–2 msec, provided the luminance gradient is very steep. As exposure increases to ~ 50 msec, the critical slope of the gradient decreases linearly.
- The appearance of Mach bands is uncertain if the border between regions of high and low illumination is maximally distinct, that is, if the α - β slope approaches infinity; likewise, as the steepness of the slope approaches zero, Mach bands disappear.

1.718 Color Assimilation

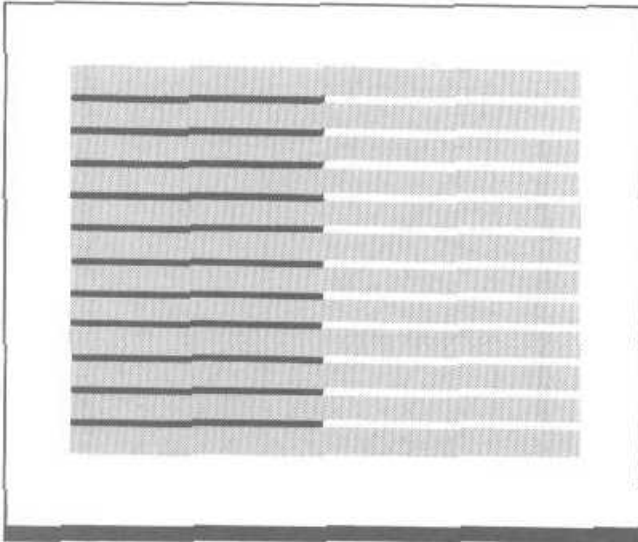

Figure 1. Configuration for demonstrating color assimilation; the uniform grey background tends to take on the color of the stripes that overlay it. If the black and white stripes are replaced by blue and yellow stripes, respectively, the grey on the left would appear bluish and the grey on the right would appear yellowish.

Key Terms

Bezold spreading effect; chromatic induction; color appearance; color assimilation; color spreading

General Description

With certain complex visual stimuli, such as patterns of stripes on a background of uniform color, the color of the background shifts toward the color of the stripes; this effect is known as *color assimilation*. Consider, for example, a uniform gray rectangular background with thin blue stripes on the left half and thin yellow stripes on the right half. Color assimilation leads to a bluish appearance for the gray in the left half and a yellowish appearance for the gray in the right half (i.e., reduced contrast between the colors). The effects of color assimilation are therefore opposite to that of simultaneous color contrast (CRef 1.717), which would result in a yellowish appearance in the gray on the left and a bluish appearance in the gray on the right (i.e. contrast enhancement). Color assimilation is also distinct from color blending, because, unlike blending, color assimilation does not involve any loss of spatial resolution. The pattern is

clearly visible despite the apparent shift in background color.

Descriptively, color assimilation represents a weighted averaging of the color of the background with that of the superimposed pattern. However, actual visual mechanisms that produce the phenomenon are not yet known.

There appears to be a continuum from color assimilation (reduced color contrast) to regular color contrast (enhanced color contrast), depending on such factors as the reflectance of the background, the size of pattern elements (e.g., the thickness of stripes), and the separation between pattern elements (e.g., distance between stripes). In general, though, color assimilation occurs with relatively fine pattern elements enclosing small areas and is replaced by color contrast as the pattern elements become thicker and more widely separated.