

N87-11225

COOLANT PASSAGE HEAT TRANSFER WITH ROTATION
A PROGRESS REPORT

F. C. Kopper
United Technologies Corporation
Pratt & Whitney

INTRODUCTION

In current and advanced turbofan engines, increased cycle pressure and temperature are employed to achieve reduced specific fuel consumption and increased thrust/weight ratios. As a result, turbine airfoils are subjected to increasingly higher heat loads which escalate the cooling requirements in order to satisfy life goals. If high turbine efficiency is to be achieved, cooling flow requirements must be kept as low as possible and the anticipated significant effect on the local metal temperatures (and ultimately on airfoil life) must be evaluated. One way to keep the quantity of cooling air bounded would be to develop more efficient internal cooling schemes. Also, development of reliable methods for predicting the thermal and aerodynamic performance of these schemes would eliminate the necessity of maintaining a safety margin surplus of cooling air.

To predict local metal temperatures, and ultimately blade life, the turbine designer faces the problem of accurately evaluating the local heat transfer from the hot gas to the blades and from the blades to the coolant flowing within the internal passages of the airfoil. Furthermore, for an acceptable design, the heat transfer must be tailored to reduce gradients while at the same time maintaining an appropriate overall level of metal temperature. To accomplish these design goals, the designer must be able to predict local boundary conditions both on the external hot gas side and the internal coolant side of the airfoil walls. These boundary conditions, which consist of the external gas driving temperature (T_g), external heat transfer coefficient (h_{ex}), internal heat transfer coefficient (h_c), and internal coolant temperature (T_c), are input to computer prediction codes that solve the heat conduction-structural aspect of the airfoil analysis, subsequently arriving at a life prediction.

To predict local coolant side heat transfer coefficients and coolant temperature rise in the cooling passages of current and advanced turbine blades is difficult because of the complex geometry of the passages and the turbulence-promoting devices that are used to achieve high levels of airfoil cooling effectiveness. Currently the design analysis of airfoil internal passage heat transfer and pressure drop relies on correlations derived for the most part from testing models in a static (non-rotating) environment. Executing tests with rotation is difficult and costly and, as a consequence, there are almost no data in the literature that a turbine designer can use with confidence to account for the effects of rotation on the internal heat transfer coefficients and pressure loss in typical turbine blade designs. Some data are available for smooth tubes over a limited range of relevant parameters, but application of these data to the complicated flow passages of a turbine airfoil would not be appropriate. As a consequence, adjustment factors are generally applied to the static test derived correlations to bring them into nominal correspondence with engine experience. This, in theory, accounts for rotation effects. Design application of computer codes to predict 3D viscous passage flow has been limited because the computer codes are in an early stage of evolution. These codes, however, offer the potential for analyzing arbitrary geometries accounting for all real-world effects.

OBJECTIVE

The objective of this 36-month experimental and analytical program is to develop a heat transfer and pressure drop database, computational fluid dynamic techniques and correlations for multi-pass rotating coolant passages with and without flow turbulators. The experimental effort will be focused on the simulation of configurations and conditions expected in the blades of advanced aircraft high pressure turbines so that the effects of Coriolis and buoyancy forces on the coolant side flow can be rationally included in the design of turbine blades.

EXPERIMENTAL MODEL

The coolant passage heat transfer model features a four-pass serpentine arrangement designed to reflect the passages in a gas turbine blade. A photograph of the partially assembled model is shown in figure 1. The radial passages have a square cross section with 12.7 by 12.7 mm (0.5 by 0.5 in.) dimensions. The model test section surfaces consist of copper segments, 10.7 by 49.3 mm (0.42 by 1.94 in.), which are heated with thin film electrical heaters. The copper segments are separated from each other with 1.5 mm (0.060 in.) strips of G-11 composite material. The copper segments are held in place with a frame constructed of G-10 composite material. G-10 and G-11 were chosen because of the low thermal conductivity and high strength.

The heat transfer coefficients on the test section surfaces are obtained from (a) heat balances on the copper segments and (b) thin film heat flux gages mounted on the segments. Pressure measurements are obtained along the straight sections and in the turns. The model instrumentation with 64 heated segments and 16 pressure measurement locations, is shown in figure 2. The 12 heat flux gages are positioned to determine local heat transfer gradients in the inlet region and on the walls downstream of the first two turns. The electrical leads from the heaters, thermocouples and heat flux gages are brought through hermetically-sealed connectors and sliprings to a computer-based data acquisition system. The pneumatic leads are brought through a leak-tight connector to 16 differential pressure transducers (ZOC model by Scanivalve) and a reference pressure transducer. The electrical signals from these pressure transducers are also routed through the sliprings to the data acquisition system.

DATA REDUCTION

Data acquisition/analysis consists of three general categories: equipment calibration, model heat loss measurement, and heat transfer coefficient calculations. The equipment calibration follows standard experimental procedures.

Next, model heat losses are determined experimentally. The model is brought up to a constant wall temperature, steady-state operating condition with no coolant flow. The energy needed to maintain constant wall temperatures then equals the energy conducted through the model walls to the environment. These values are normalized by the temperature difference between the heated copper walls and the model exterior to account for slight variations in environmental conditions during testing. This difference represents the driving gradient for conduction losses and is measured for each test.

For each copper element the net energy convected to the fluid is calculated by subtracting the electrical line losses and conducted heat losses from the total energy supplied. Bulk fluid temperatures are then calculated based on an energy balance for each flow path section as follows:

$$T_{b\text{ out}} = \frac{q_{\text{net, 4 walls}}}{\dot{m}c_p} + T_{b\text{ in}}$$

where the model inlet bulk temperature is measured. Once bulk fluid temperatures are determined, heat transfer coefficients are calculated from the equation

$$h = \frac{q_{\text{net, wall}}}{A (T_w - T_b)}$$

where T_b is the average of the inlet and exit bulk temperatures. Thus heat transfer coefficients are calculated for each individual copper wall element. This quantifies local heat transfer processes and helps isolate local effects of rotation.

RESULTS

To date experimental heat transfer and pressure drop results have been obtained for stationary conditions (no model rotation). This data will serve as the baseline for assessing the impact of rotation and buoyancy effects. Figure 3 presents the heat transfer results obtained for a Reynolds number of 25,000 which is a representative nominal value for airfoil cooling passages. This figure shows that the heat transfer downstream of the entrance and turns decays monotonically to approximately the level (marked by arrows) for fully developed flow in a square duct as established by Lowdermilk, et al. (ref. 1). The expected periodicity from pass-to-pass is achieved.

Heat transfer in the turns is approximately 2 to 2 1/2 times that of fully developed flow levels. There is no heat transfer data in the literature with which to directly compare the current results. Sahm and Metzger (ref. 2) have found heat transfer levels around 2 to 2 1/2 times fully developed values for 180-degree square cornered bends. This is in agreement with the current results. Figure 4 compares the entry length behavior for the current data with results from the literature. For the first outward straight passage the four data points (solid circles) include the guard heater region and the following three straight segments. As the flow enters the channel from the plenum it passes through a screen and begins boundary layer development. Previous measurements just downstream of the screen showed the velocity profile of the core flow to be similar to fully developed turbulent flow. Because the near wall shear flow characteristics would be similar to those of developing flow, it would be expected that the entry length heat transfer behavior be in reasonable agreement with results for combined hydrodynamic and thermal boundary layer development. This is supported by the comparisons of figure 4 (Boelter et al, ref. 3, and Aladyev, ref. 4 for pipe flow; Yang and Liao, ref. 5, for square duct flow). Heat transfer levels downstream of the first bend would be expected to be lower than for the first passage. This, again, is in agreement with observation. A creditable correlation for the effects of the bend secondary flows on the downstream heat transfer is not available.

Pressure drop measurements are shown in figure 5 for a non-heated stationary test condition at the same Reynolds number as for the heat transfer results but at a lower pressure. The results indicate a negligible pressure drop in the straight sections which is in agreement with predictions and about 0.8 dynamic heads pressure drop through each turn. This agrees with a value of 0.71 dynamic heads determined from reference 6 for connected 90-degree square elbows. The slightly higher loss for the model is believed to result from the diffusions and accelerations the flow experiences as it negotiates the area variations in the turns.

THREE-DIMENSIONAL VISCOUS FLOW COMPUTATIONS

Computation of heat transfer and pressure drop for the reported experimental conditions employing a generalized aerothermal fluid dynamic solver for three-dimensional elliptic, turbulent, steady flows has been started; results are currently not available.

TESTING WITH ROTATION

Table I defines the planned test points for the first phase (smooth passage investigation) of this program and reflects the domain of interest for turbine blade coolant passages.

REFERENCES

1. Lowdermilk, W.H.; Weiland, W.F.; and Livingood, I.N.: Measurement of Heat-Transfer and Friction Coefficients For Flow of Air in Noncircular Ducts at High Surface Temperatures. NACA Research Memorandum RME53J07, January 25, 1954.
2. Sahm, M.K.; and Metzger, D.E.: Effects of Turn Geometry Parameters on Heat Transfer Around Smooth Wall 180° Turns in Rectangular Ducts of Aspect Ratio 1.0 to 3.0. Technical Report ERC-R-83029, Mechanical and Aerospace Engineering, Arizona State University, July 1983.
3. Boelter, L.M.K.; Young, O.; and Iversen, H.W.: NACA TN1451, Washington, July 1948.
4. Aladyev, I.T. Experimental Determination of Local and Mean Coefficients of Heat Transfer For Turbulent Flow in Pipes. NACA Technical Memorandum 1356, 1954.
5. Yang, J.W.; and Liao, N.: An Experimental Study of Turbulent Heat Transfer in Converging Rectangular Ducts. Paper No. 73-WA/HT-27. ASME Journal of Heat Transfer. November 1973.
6. American Society of Heating Refrigeration and Air Conditioning Engineers: Handbook of Fundamentals, 1972, p. 472.

TABLE I
Test Matrix

Test No.	Basic Dimensionless Parameters				Secondary Dimensionless Parameters			Comments
	Re	Ro	$\frac{\Delta T}{T_{in}}$	$\frac{H}{d}$	$\frac{\Delta \rho}{\rho}$	$\frac{\Omega H}{V}$	$\frac{Gr}{Re^2}$ $Gr_{max} \times 10^{-8}$	
1	25,000	0	0.14	--	0	0	0	} Nonrotating
2	12,500	0	0.14	--	0	0	0	
3	50,000	0	0.14	--	0	0	0	
4	25,000	0.210	0.14	52	1.53	0.32	2.01	Baseline
5	12,500	0.210	0.14	52	1.53	0.32	0.50	} Re Varied
6	50,000	0.210	0.14	52	1.53	0.32	8.03	
7	25,000	0.420	0.14	52	3.06	1.28	8.03	} Ro Varied
8	25,000	0.105	0.14	52	0.76	0.08	0.50	
9	25,000	0.210	0.07	52	1.53	0.16	1.00	} $\Delta T/T$ Varied
10	25,000	0.210	0.21	52	1.53	0.48	3.01	
11	25,000	0.210	0.14	34	1.00	0.21	1.31	H/d Varied
12	25,000	0.210	0.14	52	1.53	0.32	2.01	} α Varied
13	25,000	0.210	0.14	52	1.53	0.32	2.01	

Dimensionless Parameters

Reynolds number, Re	$\rho V d_H / \mu = V d_H / \nu = \dot{m} d_H / (A \mu)$
Rotation number, Ro	$\Omega d_H / V$
Density or temperature ratio	$\Delta \rho / \rho, \Delta T / T$
Radius ratio	H / d_H
Rotational Grashof number, Gr	$Ro^2 Re^2 (\Delta T / T) (H / d_H)$

PHOTOGRAPH OF UNINSTRUMENTED COOLANT PASSAGE HEAT TRANSFER MODEL

TRAILING EDGE (+ Ω) PLANE TEST SECTIONS REMOVED

**ORIGINAL PAGE IS
OF POOR QUALITY**

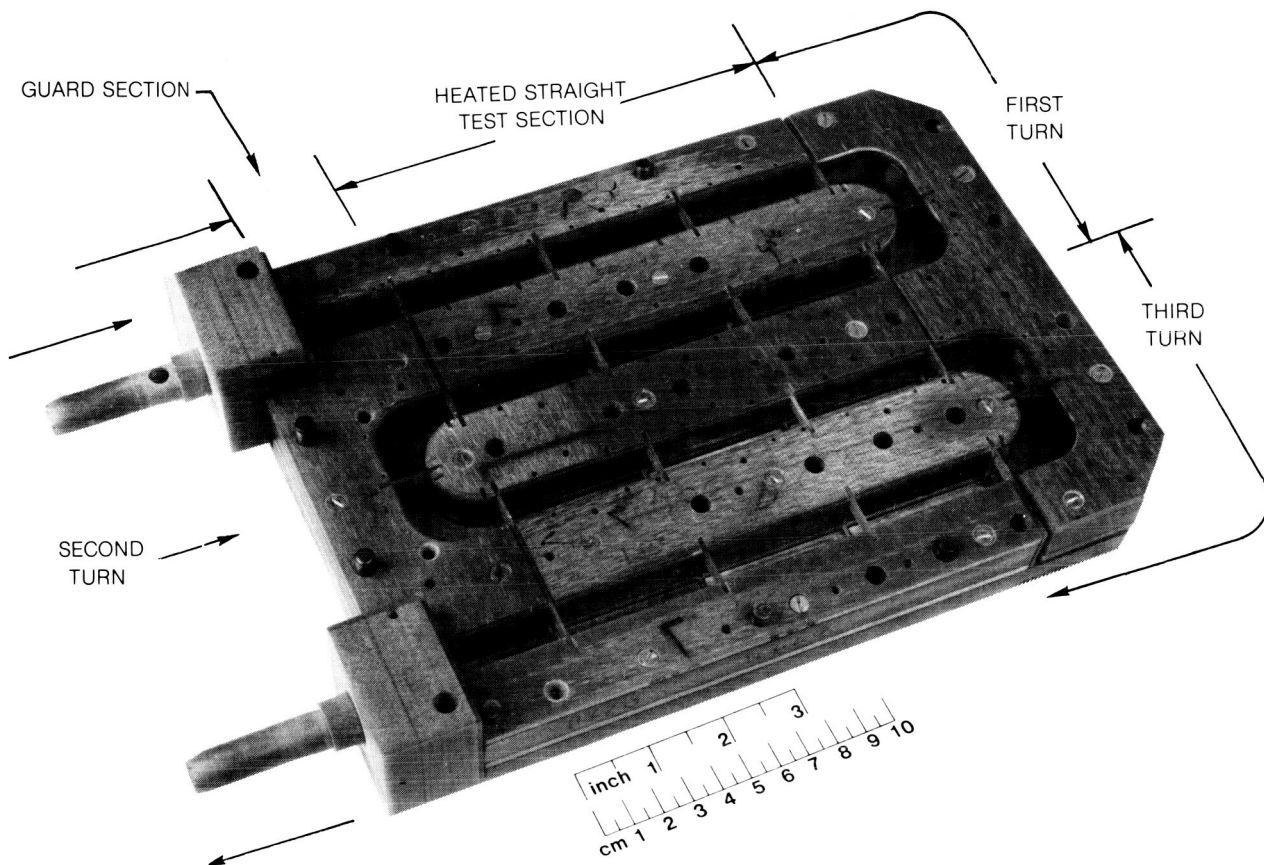

Figure 1

84-7-37-2

INSTRUMENTATION PLAN FOR COOLANT PASSAGE HEAT TRANSFER MODEL

TEST SECTION ELEMENT IDENTIFICATION:
 SURFACES 1-32 ARE ON SIDE WALLS PERPENDICULAR TO VIEW SHOWN
 SURFACES 33-48 ARE ON " $\pi + \Omega$ " LEADING PLANE
 SURFACES (49)-(64) ARE ON " $\pi + \Omega$ " TRAILING PLANE
 PRESSURE MEASUREMENT LOCATIONS 1 - 16

NOTE: EACH TEST SECTION SURFACE IS INSTRUMENTED WITH TWO THERMOCOUPLES

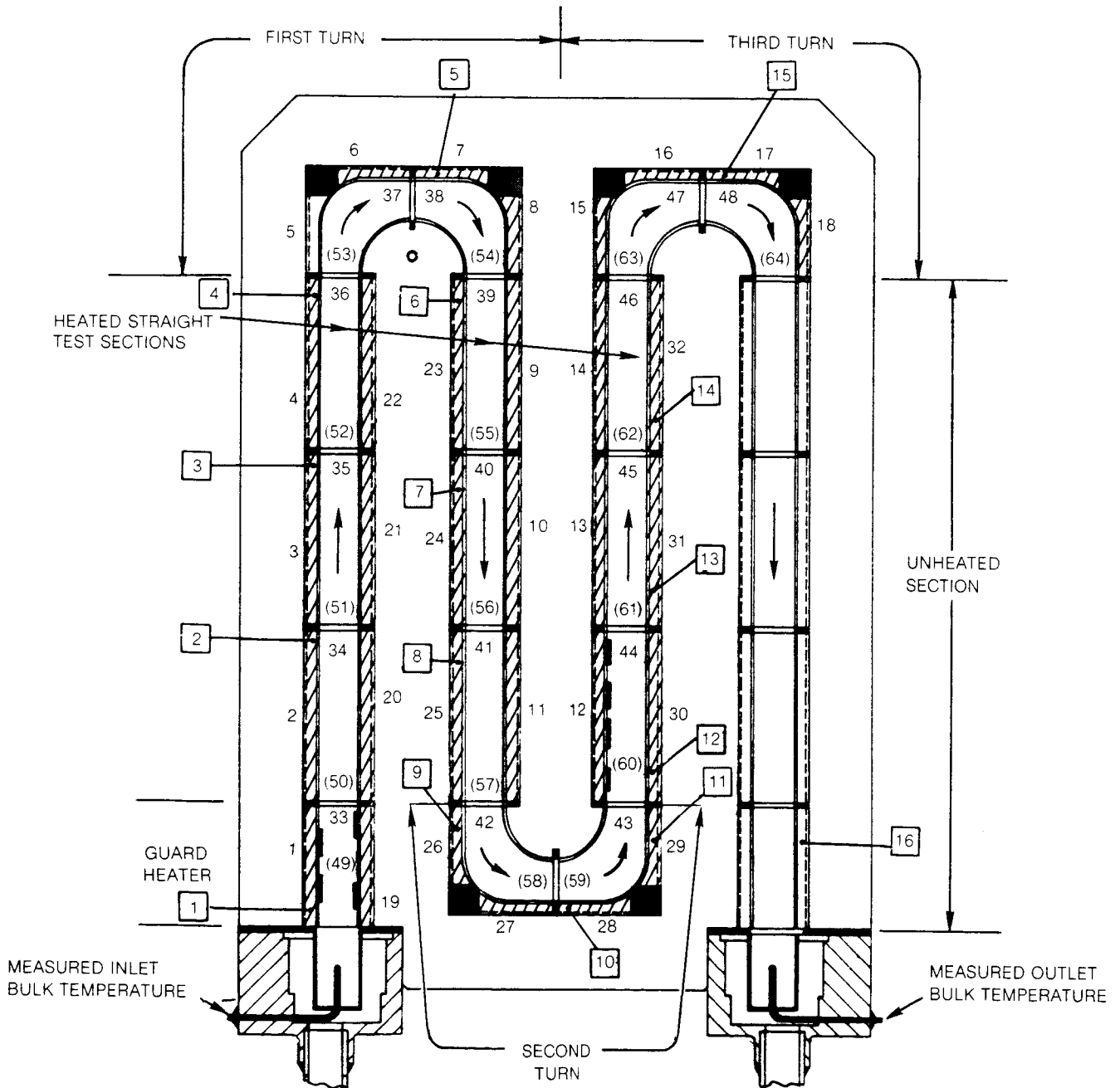

Figure 2

84-7-37-1

HEAT TRANSFER RESULTS

$\Omega = 0.0$ rpm
 $P = 146.9$ psia
 $\dot{m} = 0.0131$ lb/sec

$T_{\text{wall}} = 618^\circ\text{R}$
 $T_{\text{b' inlet}} = 538^\circ\text{R}$
 $\Delta T/T = 0.149$

$Re_{f, \text{inlet}} = 25260$
 $R_o = 0.0$
 $H/d_h = \text{---}$

LEADING AND TRAILING TEST SECTION SURFACES

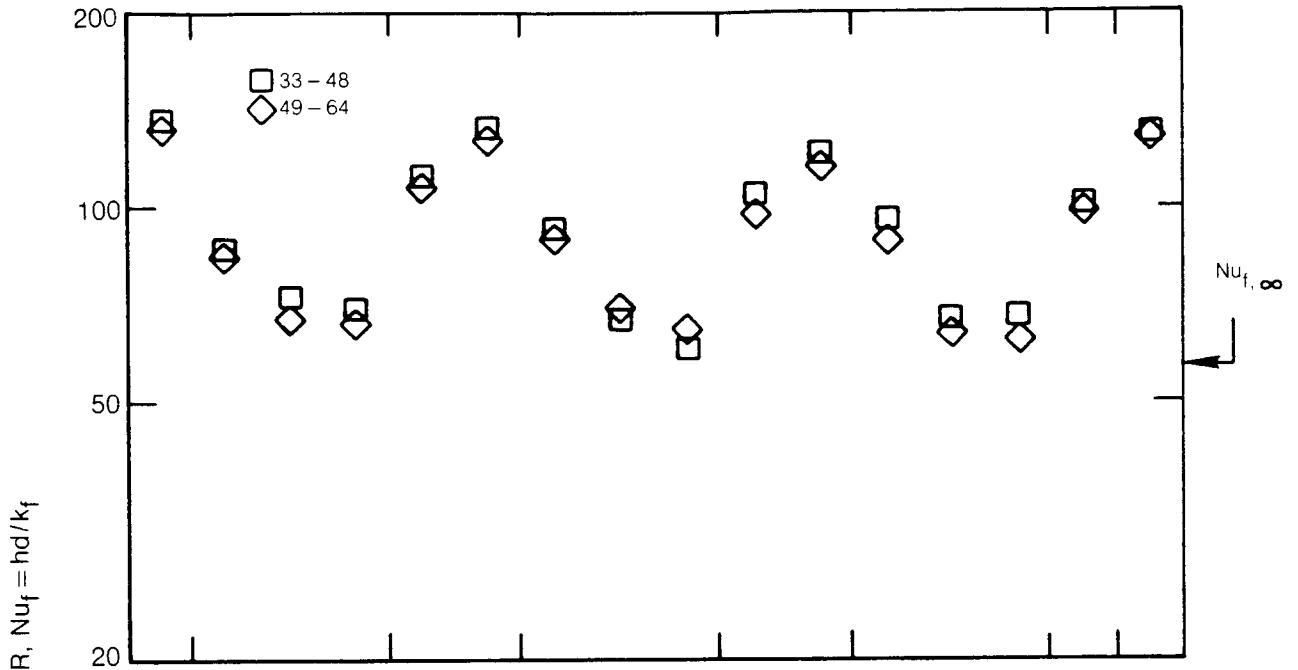

SIDE WALL TEST SECTION SURFACES

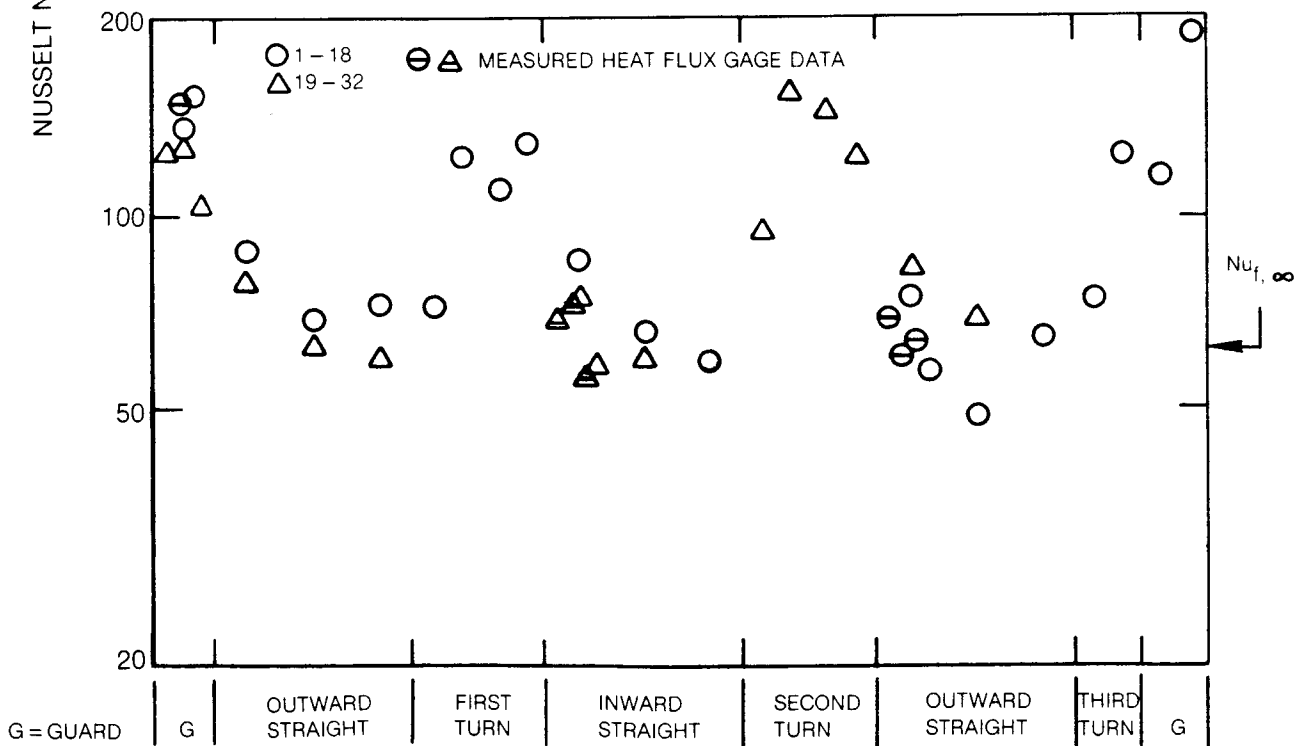

Figure 3

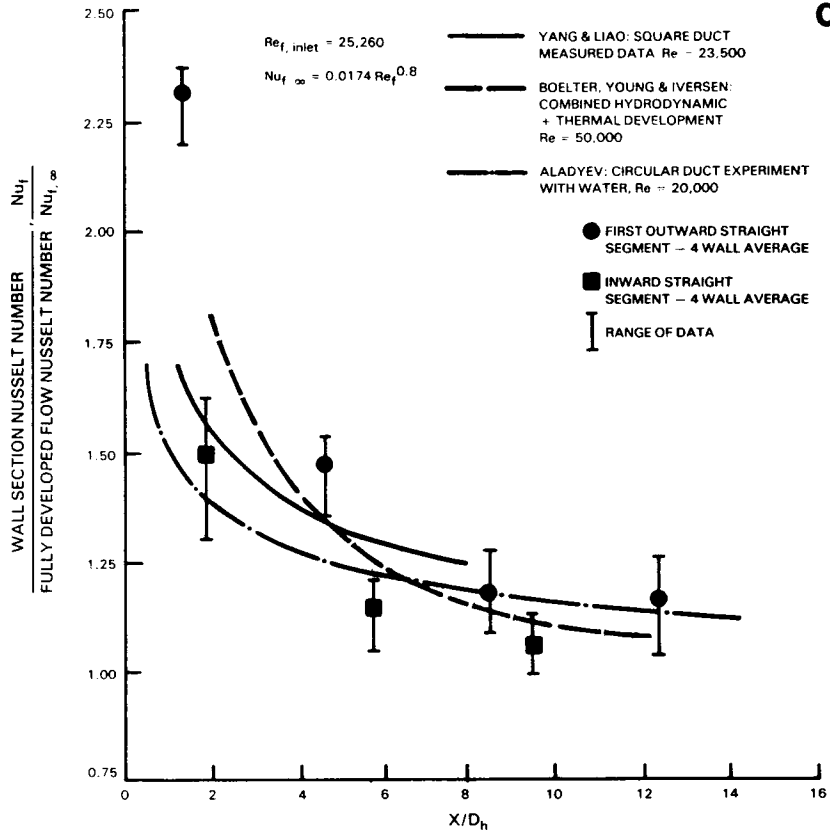

Figure 4 Entry Length Heat Transfer Comparison

PRESSURE DROP RESULTS

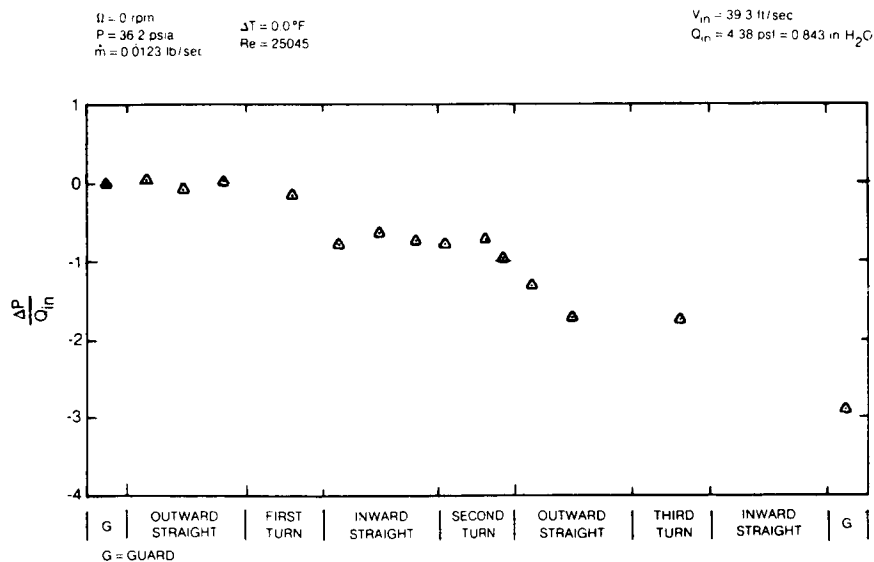

Figure 5