

NO 6 - 11103

FURTHER DEVELOPMENT OF THE DYNAMIC GAS TEMPERATURE MEASUREMENT SYSTEM

D. L. Elmore, W. W. Robinson, and W. B. Watkins
Pratt & Whitney Engineering Division

SUMMARY

Candidate concepts capable of generating dynamic temperatures have been identified and analyzed for use in verifying experimentally the frequency response of the dynamic gas temperature measurement system of reference 1. A "rotating wheel" concept and one other concept will be selected for this purpose. Modifications to the data reduction code algorithms developed in the reference 1 program have been identified and evaluated to reduce substantially the data reduction execution time. These modifications will be incorporated in a new data reduction program to be written in Fortran IV.

INTRODUCTION

The measurement system developed in reference 1 uses a compensated two element thermocouple probe. The compensation technique uses the ratio of the signal amplitudes from the two thermocouples' passive responses to gas temperature variations. Comparisons with a numerical heat transfer model allows compensation of temperature fluctuations to above 1 Khz.

The objectives (Figure 1) of the present program, "Further Development of the Dynamic Gas Temperature Measurement System", (Contract NAS3-24228) are; 1) to verify experimentally the frequency response of the dynamic gas temperature measurement system developed under a previous contract (Reference 1); 2) to optimize the computer compensation method for execution speed; and 3) to implement the reference 1 computer code in Fortran IV for use on generally available computers.

The program is organized into four basic tasks including (1) frequency response experimental verification; (2) compensation code execution streamlining; (3) implementation of the compensation code in Fortran IV; and (4) data acquisition at NASA Lewis Research Center. Efforts to date have been on Tasks 1 and 2 and the preliminary results are discussed below.

FREQUENCY RESPONSE EXPERIMENTAL VERIFICATION

Task I (Figure 2) involves designing and conducting two experiments which can be used to verify the frequency response of the dynamic gas temperature measurement system. The first experiment is defined in the contract requirements and consists of a "rotating wheel" concept. The second experiment to be designed under Task I involves the identification and evaluation of several candidate concepts and the selection of the most promising one. During the identification and evaluation of the candidate concepts consultation was provided by Dr. Robert J. Moffat of Stanford University. The experimental test conditions required for the frequency response verification are for a working fluid of air or combustion gases at a pressure of atmospheric or greater, minimum peak-to-peak temperature fluctuations of 278K

(500°F), mach number of 0.1 or greater, and temperature fluctuations of 250 Hz or greater.

Methods identified so far fall into two general categories, the first using an atmospheric pressure laboratory-scale combustor, and the second using one of a number of candidate techniques for generating periodic or step-impulse temperature signals using air as a working fluid.

An available atmospheric pressure combustor produces a dynamic temperature signal with peak-to-peak temperature variations in excess of 278K (500°F) (reference 1). The advantages of such a combustor as a temperature source are 1) the temperature spectrum qualitatively resembles the desired application (i.e. a turbine engine combustor), and 2) the assumptions of the analysis are fulfilled, namely low correlation between temperature and velocity fluctuations. Various test concepts defined for use with the laboratory burner are listed in figure 3 and discussed in the following paragraphs.

- Impulse Actuated Two Wire Probe - Two gas streams would be established having the desired high and low temperature. The probe would be moved from one to the other stream by a mechanical actuator. A small fine wire or other temperature standard would be used with the two wire probe. It is recognized that it may be difficult to attain the required 250 Hz frequency response due to the actuator speed limitations.
- Two Wire Probe and Aspirating Hot Film Probe - In this concept, the natural frequency fluctuations of the laboratory burner would be the only source of fluctuations, and a reference probe of high frequency response, such as an aspirating (TSI Model 1735) probe (figure 4) would be used as the standard measurement of the gas temperature fluctuations. The referenced TSI probe has a frequency response of up to 100K Hz and is capable of operation at 3500°C (6330°F), 152 m/s (500 f/s), and 1 atmosphere. However, the accuracy of this probe may be limited due to conduction errors.
- Two Wire Probe and Anemometer Probe - In this concept, the temperature standard would be a hot wire anemometer probe replacing the previously discussed aspirating hot film probe. The anemometer would be a high temperature probe such as a TSI Series A4 probe (figure 5) operated as a constant current temperature sensor.
- Three Wire Probe - In this concept, again the natural frequency fluctuations occurring in the combustor would be the source. An additional very small third thermocouple element would be added to the two-wire probe. This thermocouple element would provide additional verification by compensating data in three combinations: very small-small, very small-large, and small-large. Previous test experience (reference 1) suggests that very small wires (25 μ m or less) will survive for many minutes in this environment.
- Oscillating Splitter Plate and Two Wire Probe - This concept is similar to the previously described test where a splitter plate is used having two different temperature gas streams in the combustor. However, instead of moving the probe from the cold to the hot stream the splitter plate would be oscillated mechanically to divert the streams over a stationary probe assembly and temperature standard. The principal difficulties in this

concept is in making certain that the flow stays attached to both faces of the splitter plate and in the complex mechanical system required.

The second category of verification experiments involves hardware configurations which use air as the working fluid and which suggest an obvious temperature variation. The configurations are:

- Rotating Wheel - The original rotating wheel experiment which has been tested at Pratt & Whitney is shown in Figure 6. It consists of two rotating wheels which have circles of holes which turn the air flows (hot and cold) on and off. The hole patterns are phased to alternately heat and cool the test probe which is positioned between the wheels. Phasing of the two hole patterns suggests a temperature variation, i.e, if the holes in pattern "A" are 180° out of phase with the holes in pattern "B", an approximate square-wave temperature variation will result as the wheels are rotated. The primary frequency is the number of holes in one pattern multiplied by the rotation rate, and peak-to-peak variation in temperature is the difference in stream temperatures. Figure 7 presents typical test data for the temperature and velocity profiles.
- Modified Rotating Wheel - One of the drawbacks to the previously described rotating wheel is that the streams flow in opposite directions. Based on recommendations from Dr. Robert Moffat the rotating wheel experiment was modified (Figure 8) to use one wheel with two hole patterns and collector/transition duct which blends the two gas streams through a single nozzle at the probe. Proper design of the phasing of the holes and using a screen in the transition duct should make it possible to achieve a nearly sinusoidal temperature waveform, which is preferred.
- Blow Down Tube - This concept (figure 9) would use a burst diaphragm and a capacitive heater to provide a step input. The disadvantages to this system are problems with probe damage due to particles from the burst diaphragm and inaccuracy resulting from not generating a sharp instantaneous step function.
- Pulsatile Pressure System - This system, shown in Figure 10, consists of a flow channel with two orifices. The first orifice is operated critically so the flow is constant. The second orifice would be periodically occluded by a rotating disk valve which would cause the pressure in the volume between the orifices to fluctuate. This would result in temperature fluctuations due to isentropic compression. The primary disadvantage is the large variations in flow required to produce the temperature fluctuations.
- Piston In Cylinder - This system, shown in Figure 11, again uses two orifices but uses a piston to compress the gas between the orifices and thus obtain a temperature fluctuation. This system still has a flow variation, however, it is smaller than the pulsatile system.
- Sprinkler Head - This concept, shown in figure 12, consists of a wheel made from two halves containing milled passages. The passages are curved so that the air flow will provide the momentum to rotate the assembly. The passages would also be canted slightly in the axial direction so that the flow from each stream would impinge on the test probe located near the

wheel. This configuration has the advantage of providing temperature fluctuations with a relatively uniform and constant velocity. The primary disadvantages would be associated with the large amount of air required and the complexity of designing the rotating seals and bearings.

- Fluidic Oscillator - This concept, shown in figure 13, is based on a modification of a fluidic switch to oscillate two streams (hot and cold). Switching of the two flow streams (hot and cold) would be achieved by alternately applying pressure pulses to the control ports. The pressure pulses could be supplied by a rotating valve assembly. The probe would be positioned in the area shown in figure 13.

The principal difficulty with the above methods concerns the degree of correlation between velocity fluctuations and temperature fluctuations, and consequent applicability of the compensation method.

The concepts will be evaluated for technical merit and subsequent selection of the most promising method.

COMPUTER CODE OPTIMIZATION

Task II, Compensation Code Execution Streamlining, involves developing a more efficient numerical compensation method. In the reference 1 numerical method (Figure 14) thermocouple response is calculated at each of several individual frequencies, and the compensation spectrum is derived by cumulating individual frequency results. The calculation time may be shortened through the following approach (shown in Figure 15). Unit amplitude input frequency over the bandwidth of interest is first inverse Fourier transformed to yield an impulse function, which then can be used as time-dependent boundary condition for the thermocouple response calculation. Fourier transform of thermocouple response then yields the compensation spectrum directly. Calculation time is greatly reduced with the impulse function approach. The remainder of the compensation method involving ratios of the two thermocouple outputs remain unchanged.

REFERENCE

1. Elmore, D. L., Robinson, W. W., and W. B. Watkins, "Dynamic Gas Temperature Measurement System Final Report, Vol. I, Technical Efforts", prepared for NASA-Lewis Research Center by United Technologies, Pratt & Whitney, Contract No. NAS3-23154, Report NASA CR-168267, 10 May 1983.

FURTHER DEVELOPMENT OF THE DYNAMIC GAS TEMPERATURE MEASUREMENT SYSTEM

- Objectives
 - Experimentally verify the frequency response
 - Optimize the computer compensation methods
 - Implement the code in FORTRAN IV
- Talk outline - progress report on
 - Definition of experimental test concepts
 - Preliminary results of concept analyses
 - Preliminary results of computer code optimization

Figure 1

EXPERIMENTAL VERIFICATION CONCEPTS

Laboratory burner concepts

- Impulse actuated 2 wire probe
- 2 wire probe and TSI probe
- 2 wire probe and anemometer probe
- 3 wire probe
- Oscillating splitter and 2 wire probe

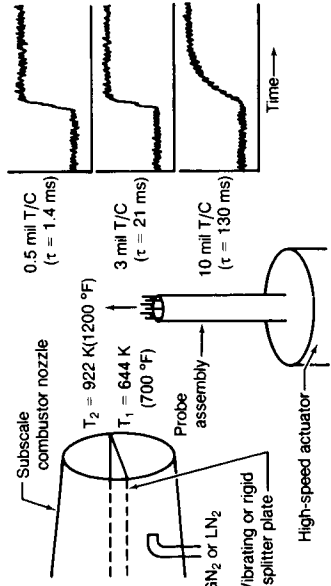

Figure 3

EXPERIMENTAL VERIFICATION

Task I

- Requirements
 - Conduct surveys to define experimental test concepts
 - Analyze, rank, and select 1 concept to be tested in addition to the rotating wheel
 - Fabricate, test, and analyze results
- Test conditions
 - Frequency response: 250 Hz (min)
 - Temperature fluctuations: 278K (500°F) P-P (min)
 - Pressure: atmospheric or greater
 - Flow rate: Mach 0.1 (min)
 - Gas composition: air is acceptable

Figure 2

LABORATORY BURNER TEMPERATURE STANDARD

TSI aspirating probe

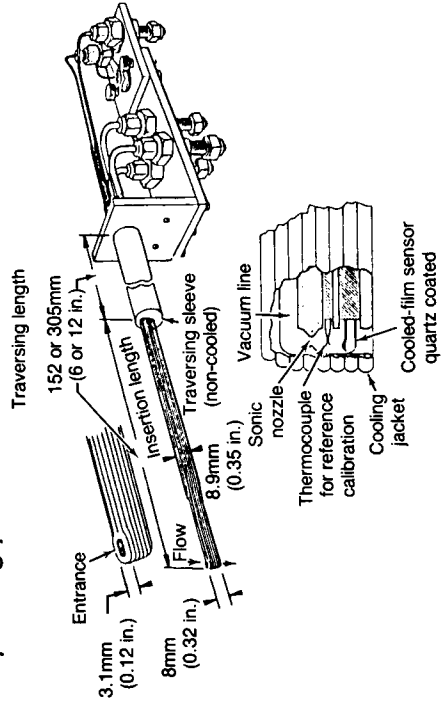

Figure 4

LABORATORY BURNER TEMPERATURE STANDARD

High temperature anemometer probe

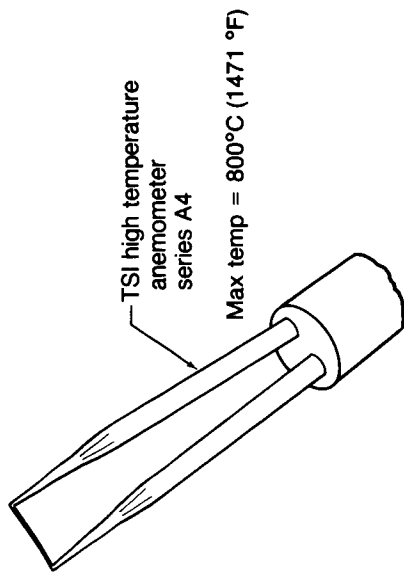

Figure 5

EXPERIMENTAL VERIFICATION CONCEPTS

Existing rotating wheel schematic

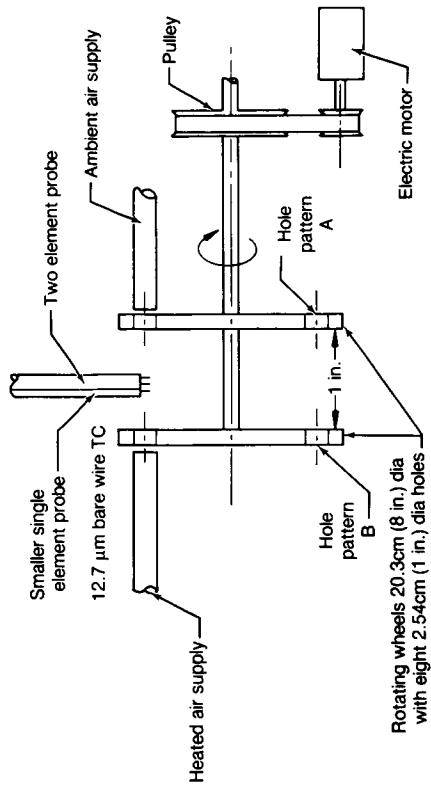

Figure 6

EXPERIMENTAL VERIFICATION CONCEPTS

Modified rotating wheel schematic

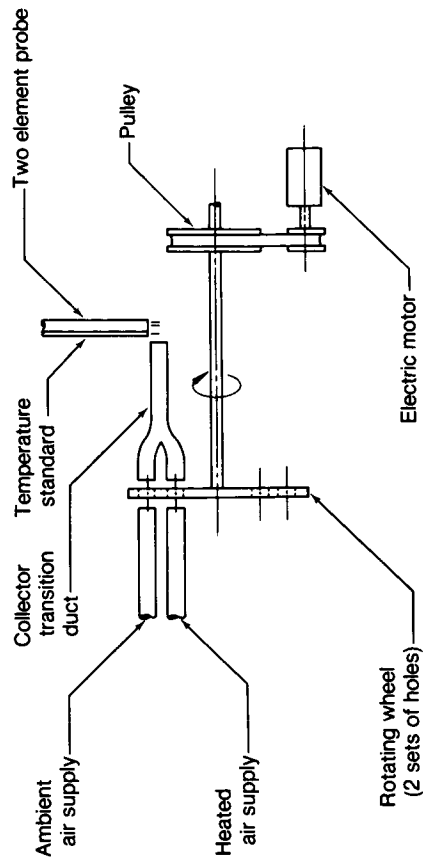

Figure 8

EXISTING ROTATING WHEEL CONCEPT

Typical test data

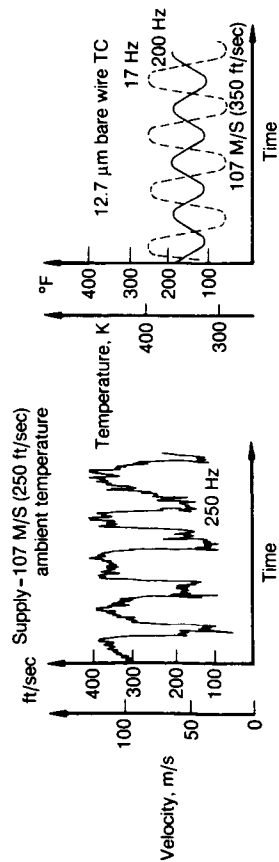

Figure 7

EXPERIMENTAL VERIFICATION CONCEPTS

Blowdown tube

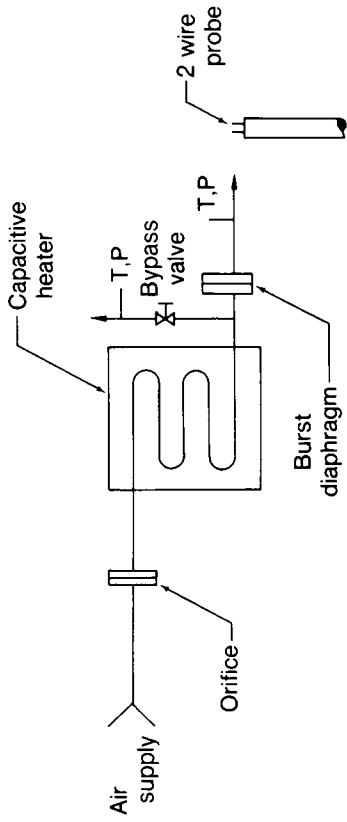

Figure 9

EXPERIMENTAL VERIFICATION CONCEPTS

Piston in cylinder

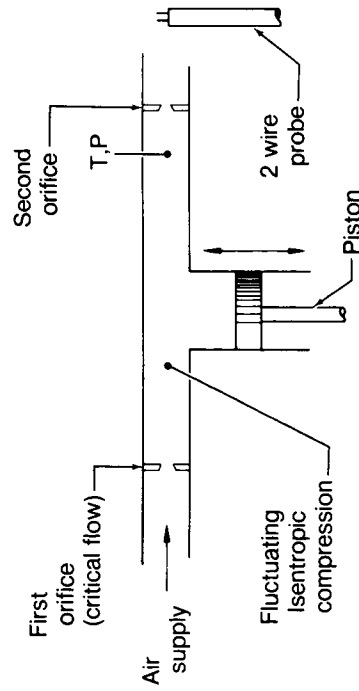

Figure 11

EXPERIMENTAL VERIFICATION CONCEPTS

Pulsatile pressure system

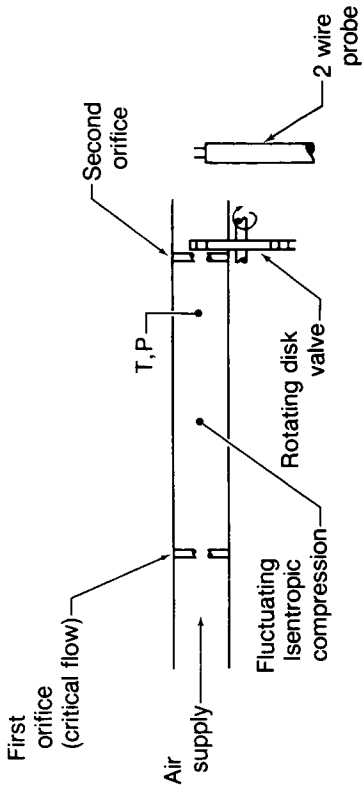

Figure 10

EXPERIMENTAL VERIFICATION CONCEPT

Sprinkler head

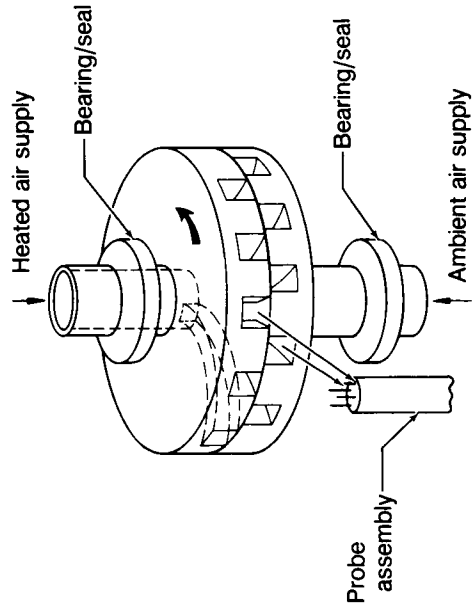

Figure 12

EXPERIMENTAL VERIFICATION CONCEPT

Fluidic oscillator

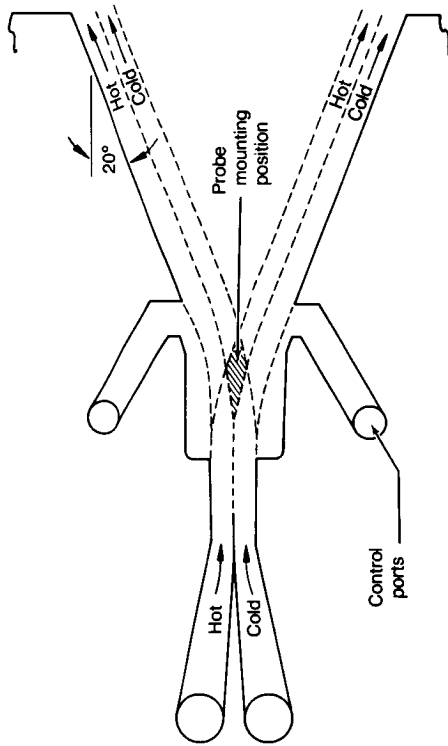
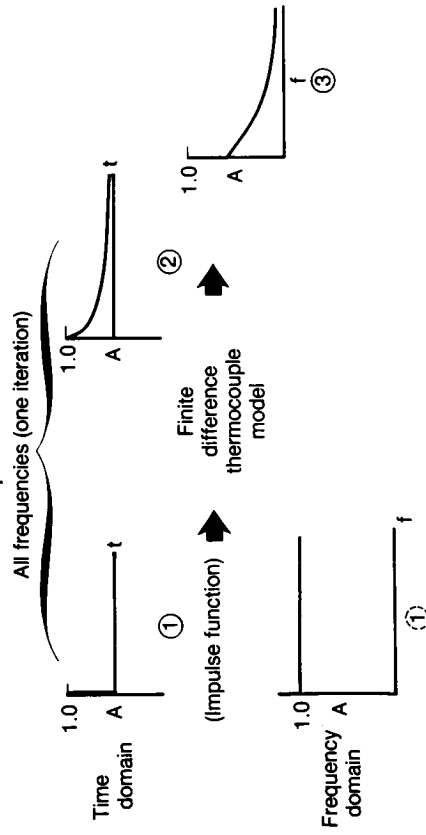

Figure 13

COMPUTER CODE OPTIMIZATION

Advanced numerical compensation method



- Impulse function handles all frequency components simultaneously

Figure 15

COMPUTER CODE OPTIMIZATION

Original numerical compensation method

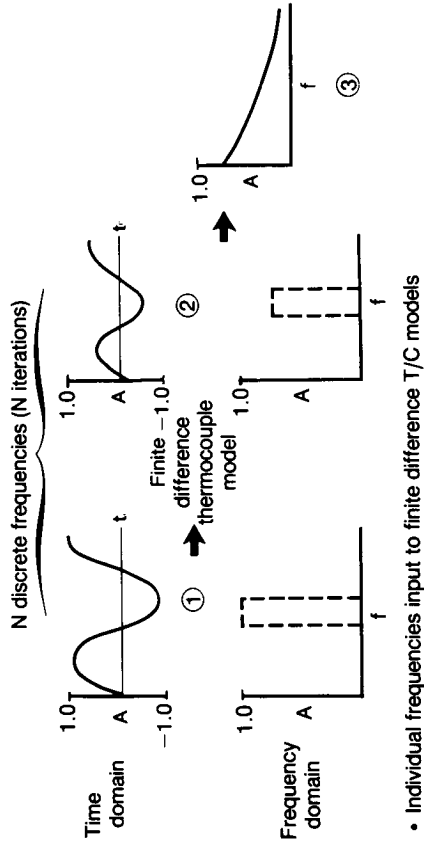

- Individual frequencies input to finite difference T/C models
- Output from model complex added to yield compensation spectrum

Figure 14