

N87-11088

Self-Discharge Characteristics
of Spacecraft Nickel-Cadmium Cells at Elevated Temperatures

Paper to be Presented at the
1985 NASA/GSFC Battery Workshop

November 19-21, 1985

by

S. W. Donley, J. H. Matsumoto, and W. C. Hwang
The Aerospace Corporation
P. O. Box 92957
Los Angeles, CA 90009

VUEGRAPH 1

Little is known concerning the self-discharge and heat generation in nickel-cadmium cells when they are subjected to temperatures far in excess of ambient. It is known that in general the rate of chemical energy loss from the cells in the form of heat increases with temperature and that thermal runaway is a likely result at sufficiently high temperatures, even with cells on open circuit. Actual conditions promoting thermal runaway have heretofore not been established. The work reported here provides such data in tests performed on open-circuited NiCd cells, fully charged, when such cells were heated externally to temperatures from 40°C to 120°C.

VUEGRAPH 2

The objective of this paper is to relate the effects of heat generation in spacecraft nickel-cadmium (NiCd) cells during high temperature storage on open circuit. When nickel cadmium batteries are open circuited in the charged state, chemical reaction(s) provide a means of self-discharge and heat-generation. The rates of self-discharge and heat-generation are relatively low at normal spacecraft operation temperatures (-5 to 30°C); however, the rates and possibly the complexity of the reactions increase with temperature. There is little data available concerning capacity losses via self-discharging in NiCd cells due to elevated temperature (above 40°C) exposure. Such data could be useful in space programs, as temperatures in the range 80-100°C may cause the batteries to become thermally unstable. Additional heating generated by battery self discharge may drive the batteries into catastrophic failure with consequence for the integrity of the spacecraft and its contents. The testing described here was designed to

determine the extent to which battery thermal stability is a valid concern, at temperature of exposure (externally effected) between 40°C and 120°C.

VUEGRAPH 3

The NiCd cells selected for testing are General Electric catalog number 35AB11, 35 Ah nominal capacity. It is expected that the results obtained with these cells can readily be extended to other NiCd spacecraft batteries.

The cells were enclosed in an insulating container (Fibrothal (Reg.), Kanthal Furnace Products Co.) prior to test. The cell test apparatus is shown in vuegraph 3, which is not drawn to exact scale in order to show some of the details. The large faces of the cell were supported by 1/4 inch aluminum restraints which were held together by 4 screws (not shown in drawing). The cell and restraints were designed to slip into the aluminum liner along with the heater and aluminum shims to provide a snug fit. All sliding pieces were coated with silicon heat conducting compound. The liner was bonded to the glass foam insulation with a high thermal conductivity RTV compound. Empty spaces within the glass foam insulator (top, bottom, and small faces of cell) were filled with glass wool. Thermistors were mounted at the top and bottom of the cell, on the outside of the cell restraint opposite the heater, on the inside of a small face of the liner, on two outside surfaces of the foam insulator, and at the bottom of the foam insulator. A strain gauge was placed on either the cell top or bottom in order to monitor any possible bulging of the cell case.

VUEGRAPH 4

The insulated test assembly was operated inside an environmental chamber. The seven thermistors and the strain gauge measurements were monitored by a computer which also controlled the heater, the insulator, and the temperature of the environmental chamber. Calibrations of the thermistors, specific heat of a cell, specific heat of the test apparatus, and thermal conduction through the test apparatus were made with a solid aluminum "dummy cell" of known specific heat. At a given environmental chamber temperature, the heater inside the assembly provided sufficient heat for particular initial internal temperatures.

VUEGRAPH 5

Measurements of temperature after heating provided the necessary calibration data. While the initial external (environmental chamber) temperature was to be 60°C, the internal temperatures for the determination were 60, 80, 100, 120, 140, and 160°C. The thermal processes operating in the experimental

test fixture during the calibration runs with a dummy cell of known heat capacity (b') are described by the equation:

$$(1) \quad a \int_{\tau_1}^{\tau_2} [T(t) - T'(t)] dt + \frac{c}{2} [T(\tau_2) - T(\tau_1) + T'(\tau_2) - T'(\tau_1)] = b' [T(\tau_1) - T(\tau_2)]$$

where a is the constant for heat loss through the insulator to the environment, and c is the heat capacity of the insulator, and where $T(t)$ = temperature of cell as a function of time, and $T'(t)$ = temperature of chamber as a function of time.

VUEGRAPH 6

VUEGRAPH 6 is a computer plot of actual data for selected thermistors from one of the "dummy cell" runs, which were performed in order to determine the heat dissipation rate through the walls of the cell insulating container at various temperatures of the container/contents and the surrounding thermal chamber. In this case both the dummy cell and the chamber were brought initially to 60°C, then the cell heaters were disconnected and the dummy cell surface temperatures were monitored for one hour. In this way the dummy cell was heated to successively higher temperatures, and the temperatures with no cell heating were monitored. The chamber temperature, nominally constant, demonstrated a small upward drift throughout the test, in addition to a significant ripple associated with each cell heating and cooling cycle.

VUEGRAPH 7

The values of the insulator heat capacity, c , and the rate of heat dissipation through the walls of the insulator, a , were determined from analysis of the thermistor data during the periods of active heating and by determining the cooling rates (heaters off) respectively.

The heat capacity (b) of the actual 35 Ah cells that are the subject of this paper were determined by calculation from the materials of construction of the cells. The value obtained for a fully discharged cell was then adjusted by calculation to account for the differences in the heat capacitance between the charged and discharged active cell materials. A value of ΔH (cell) of 0.235 Wh/°C (202 cal/°C) was derived from this calculation, in good agreement with data found in the literature.⁽¹⁾

VUEGRAPH 8

In the cell testing, fully charged cells were fastened between restraining plates, fitted with thermistors, etc., and inserted into the insulating housing in the same way that the dummy cells were treated

earlier. The experiments were performed with fully charged cells at initial internal and external temperatures of 44, 64, 82, 85, and 118°C. The temperatures following the initial heating were monitored for up to 48 hours and provided the data necessary for calculating the self-heat generation of these NiCd cells in this temperature range. The same two cells were used for the 60° tests that were tested at 40°, after recharge. Otherwise, fresh cells were used in each cell temperature test. The testing procedure was to heat the test chamber to the preset test temperature, then to heat the cells to approximately the same temperature via timed resistance heaters contained inside the insulators, in contact with the cell surface, at the rate of ~ 2°C/min. In vuegraph 8 are shown the actual cell wall temperatures achieved at the completion of the heating period, and also the maximum temperatures achieved.

VUEGRAPHS 9, 10, 11

Example cell and chamber actual temperature data (for simplicity not all thermistor outputs are shown) appear in vuegraph 9-11. In all these plots the chamber temperature was subjected to a periodic perturbation, arising from an idiosyncrasy in the test computer database that caused the chamber heaters to activate at 8 hr intervals. One hour after the Tenney chamber reached the setpoint temperature the cell heaters were fed a predetermined amount of energy, calculated from the cell constant, and sufficient to bring the cells and other contents of the insulating containers to the setpoint temperature. Thereafter the chamber temperature was maintained and both chamber and cell temperatures were monitored. As in the earlier calibration runs each cell had five thermistors attached to it, and three thermistors were attached to the outside surface of the insulator. The thermistor readings were monitored at intervals throughout the test and the data stored on floppy disks. Values of all the cell surface temperatures were averaged prior to the succeeding calculation of self discharge rates, as were chamber temperatures.

The calculation of cell self discharge rates assumed that all cell capacity and energy losses were converted entirely to heat, and that the heat dissipation rate through the walls of the insulator and the cell thermal capacity derived earlier are valid at all temperatures of the testing. The cell discharge rates, q , at various temperatures were calculated from actual time/temperature data and the calculated slopes of the time/temperature plots with the following equation:

$$(2) \quad q(\tau) = \left(b + \frac{c}{2} \right) \frac{dT(\tau)}{dt} + \frac{c}{2} \frac{dT'(\tau)}{dt} + a [T(\tau) - \tau'(T)].$$

VUEGRAPH 12

The calculated cell heat generation data are plotted (as $\log q$ v. T^{-1} in vuegraph 12 together with error bars. The errors are greater at the lower temperatures because at these temperatures the derived heating rates are dominated by the term in the equation requiring the determination of small temperature differences. Previous 40°C data are shown for comparison reference 2 (Scott, et al., shown in Vuegraph 12). These data can now be used to evaluate thermal runaway conditions for any battery system with a known thermal control properties. The data should be scalable to other cell sizes.

VUEGRAPH 13

We earlier described a cell as having "exploded" at cell surface temperature in excess of 230°C. At the calculated rate of heat generation (> 500W) at a few minute before the catastrophic event occurred it is likely that the actual temperature at points within this cell were well in excess of that measured at the cell surface. At these temperatures the separator material fused, allowing the electrode materials to come into intimate contact. Although we do not have information adequate to judge whether an explosion indeed occurred or merely a forceful venting, a decided odor of organic combustion was detected in the surrounding laboratory area after the event. Photographs of the cell chamber and its environmental chamber are shown in vuegraph 13. The heavy stainless steel walls of the environmental chamber were bowed outward and the door hinges were bent, in spite of a 4 inch diameter hole having been provided for pressure dissipation. As can be seen in the photos, the 1/4 inch aluminum restraining plates over the cell faces were bent but held, while all four side panels of the cell were blown free. The electrode sinter was covered by black frangible dust which was all that was left of the active material

VUEGRAPH 14

The conclusions of this study are that thermal runaway can occur from elevated temperature self-discharge of NiCd batteries. Thermal runaway can be fast enough to rupture cells in batteries and cause physical damage in the surrounding area. In our particular case battery temperatures above about 80 deg. C cannot be allowed without adequate provision for heat dissipation.

References

1. A. Laursen and P. H. Jacobsen, "Analysis and Testing of the Thermal Properties of Space Battery Cells," European Space Agency Contract No. 498/82/NL/JS(SC), January 1983.
2. W. R. Scott and D. W. Rusta, "Sealed-Cell Nickel-Cadmium Battery Applications Manual," NASA Reference Publication 1052, December 1979, p. 101.

VUEGRAPH 1

HEAT GENERATION FROM SELF-DISCHARGE OF
NICKEL-CADMIUM CELLS AT ELEVATED TEMPERATURES

BY

S. W. DONLEY, J. H. MATSUMOTO, AND W. C. HWANG
THE AEROSPACE CORPORATION
P. O. BOX 92957
LOS ANGELES, CA 90009

NOVEMBER 20, 1985

VUEGRAPH 2

OBJECTIVE

* TO DETERMINE THE HEAT GENERATION IN SPACECRAFT NiCd CELLS DURING OPEN CIRCUIT STAND AT ELEVATED TEMPERATURES

METHOD

* ENCLOSE CELLS (AT 100% S.O.C.) IN INSULATIVE CONTAINERS AT ~ADIABATIC CONDITIONS AT T: 40° to 120°C

* FOLLOW TEMPERATURE PROFILES OF CELLS AND SURROUNDINGS.

* CALCULATE CELL HEAT GENERATION RATES VERSUS TEMPERATURE

Thermal Test Assembly

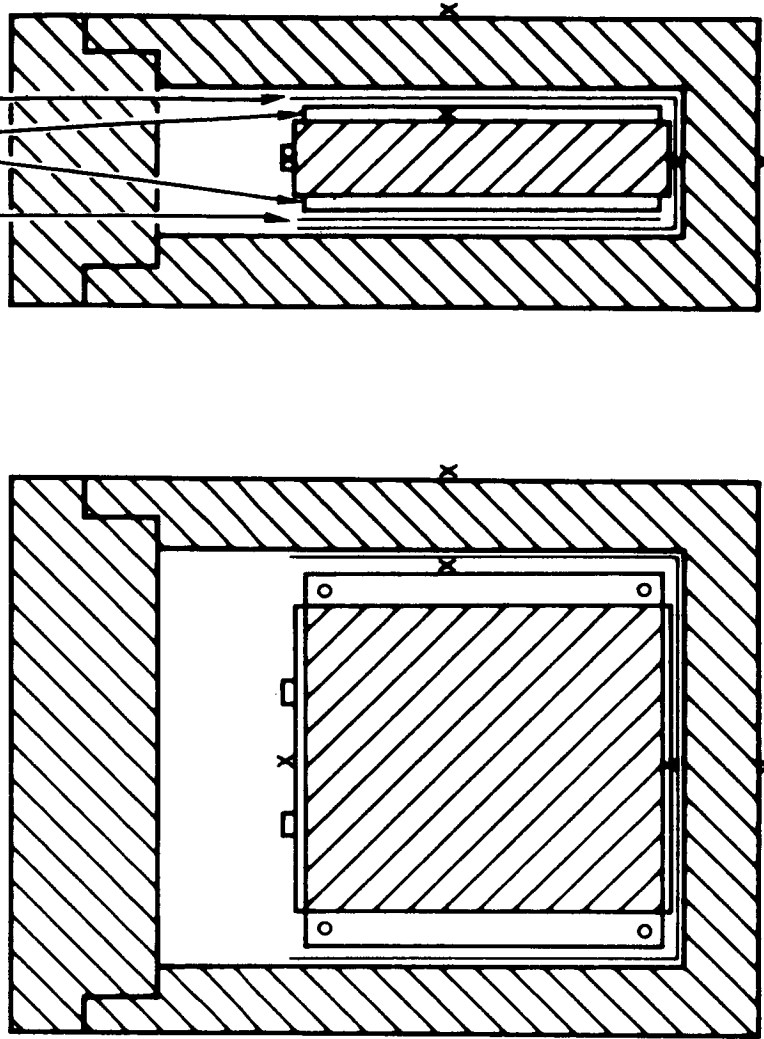
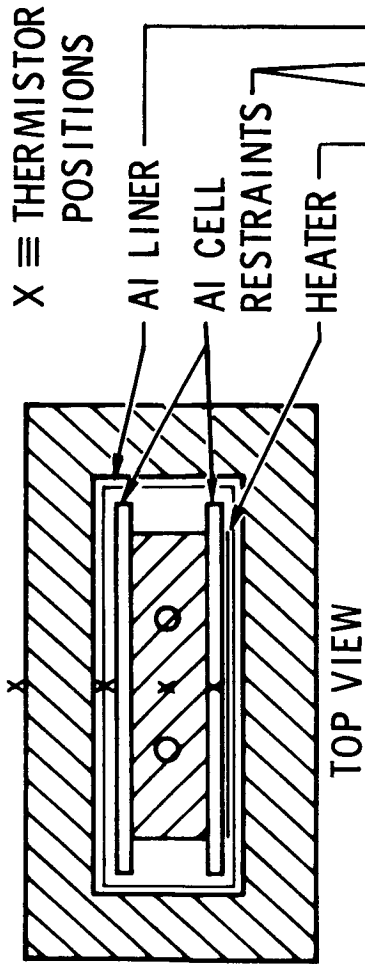

X ≡ THERMISTOR POSITIONS

AI LINER

AI CELL

RESTRAINTS

HEATER

TOP VIEW

END SECTION

SIDE SECTION

NOT TO EXACT SCALE

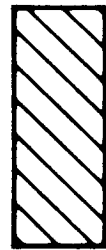

GLASS FOAM INSULATION

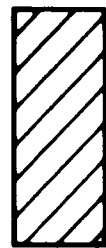

CELL



Block Diagram of Test Apparatus

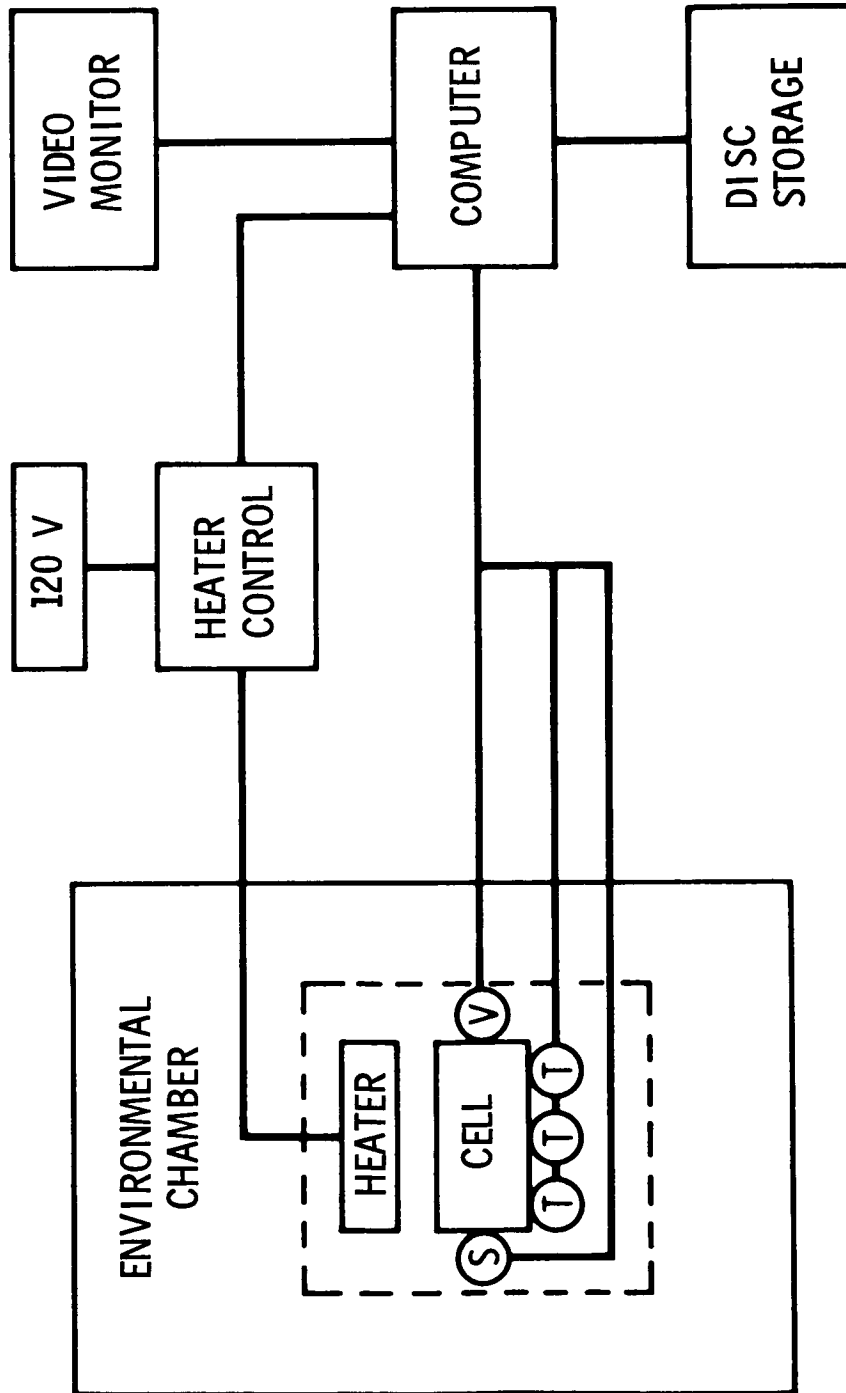

CALIBRATION OF TEST APPARATUS

- * INSULATOR CONSTANTS DETERMINED WITH "DUMMY" CELL OF KNOWN HEAT CAPACITY:
 - * CONSTANT FOR HEAT LOSS RATE THROUGH INSULATOR (W/DEG)
 - * CONSTANT FOR HEAT CAPACITY OF INSULATOR (Wh/DEG)
- * CELL CONSTANT FOR A 35 Ah NiCd CELL
- * HEAT CAPACITY OF DISCHARGED CELL (Wh/DEG), CALCULATED AND VERIFIED EXPERIMENTALLY
- * CORRECTION FOR FULLY CHARGED CELL, BY CALCULATION

$$a \int_{t_1}^{t_2} [T(t) - T'(t)] dt + c/2 [T(t_2) - T(t_1) + T'(t_2) - T'(t_1)] = b' [T(t_2) - T(t_1)]$$

where a is constant for heat loss through insulator

c is heat capacity of insulator

b' is heat capacity of "dummy" cell

$T(t)$ is the cell temperature as a function of time

$T'(t)$ is chamber temperature as function of time

VUEGRAPH 6

Temperature vs Time

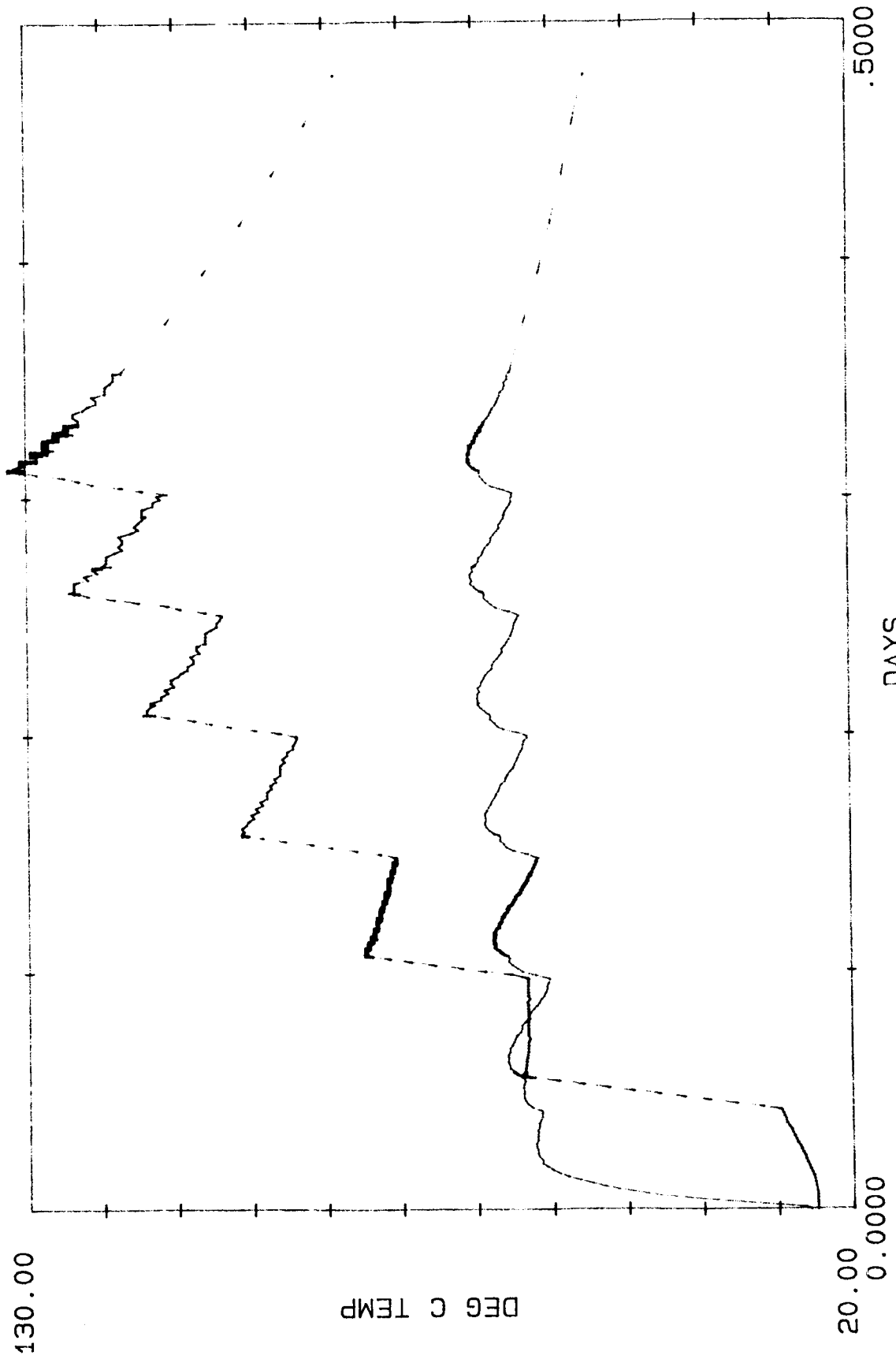

THERMAL PARAMETERS

Heat Dissipation Rate: 0.126 W/deg C

Cell Heat Capacity: 0.235 Wh/deg C

Cell Restraints

Heat Capacity: 0.216 Wh/deg C

Insulation Heat Capacity: 0.156 Wh/deg C

VUEGRAPH 8

CELL TEMPERATURE DATA SUMMARY

<u>NUMBER OF CELLS TESTED</u>	<u>INITIAL TEMP DEGREES C</u>	<u>CELL TEMP. ACHIEVED AT END OF TEST, ° C</u>	<u>ENVIRONMENTAL CHAMBER TEMP DEGREES C</u>
2	~44	42	36 - 38
(2)¹	~64	64	58 - 59
2	~82	85	70 - 72
2	~85	>166²	72 - 79
1	~118	230	121 - 129

1. SAME CELLS AS 40°C TEST
2. CELLS WERE FULLY DISCHARGED

Temperature vs Time

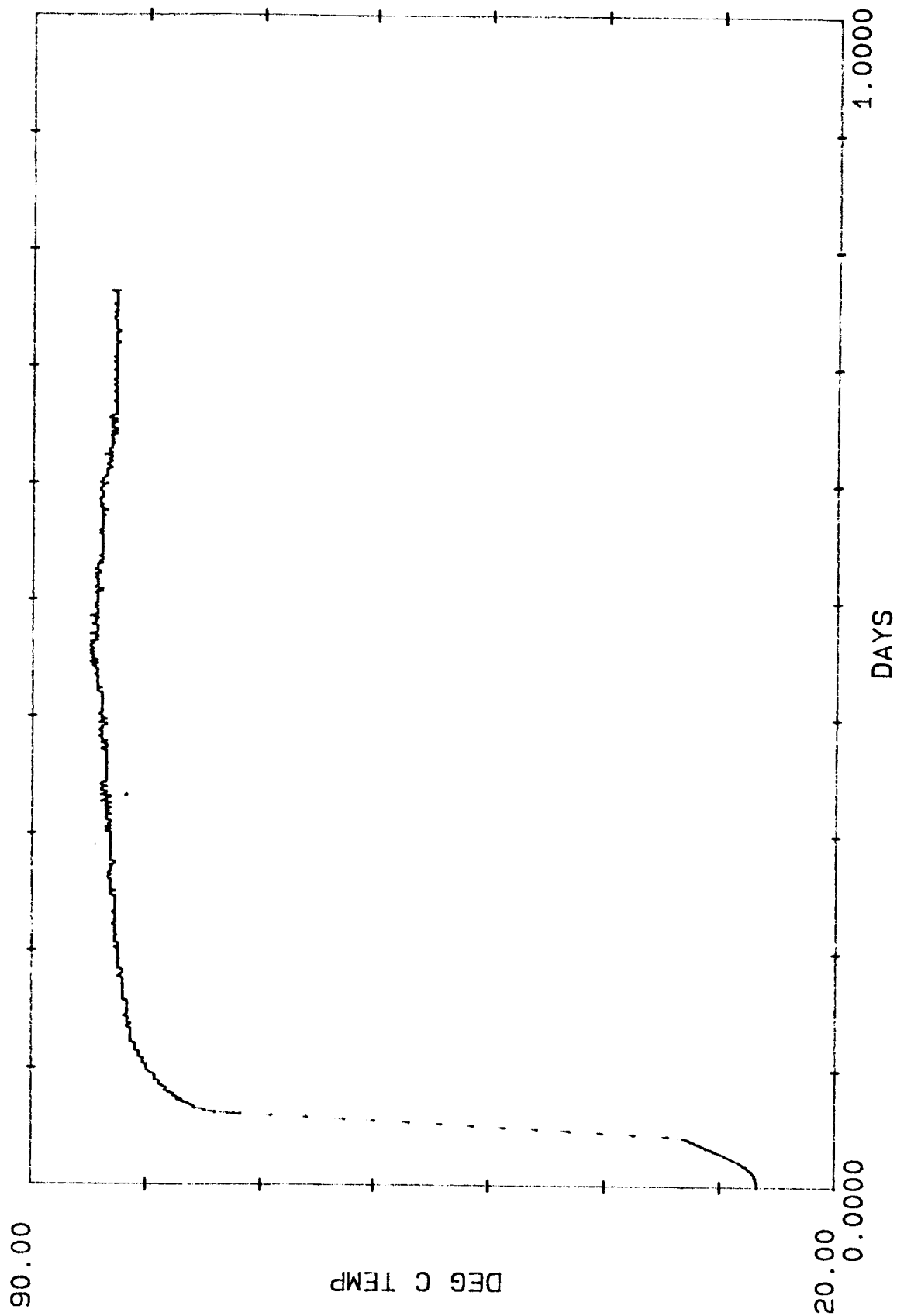

VUEGRAPH 10

Temperature vs Time

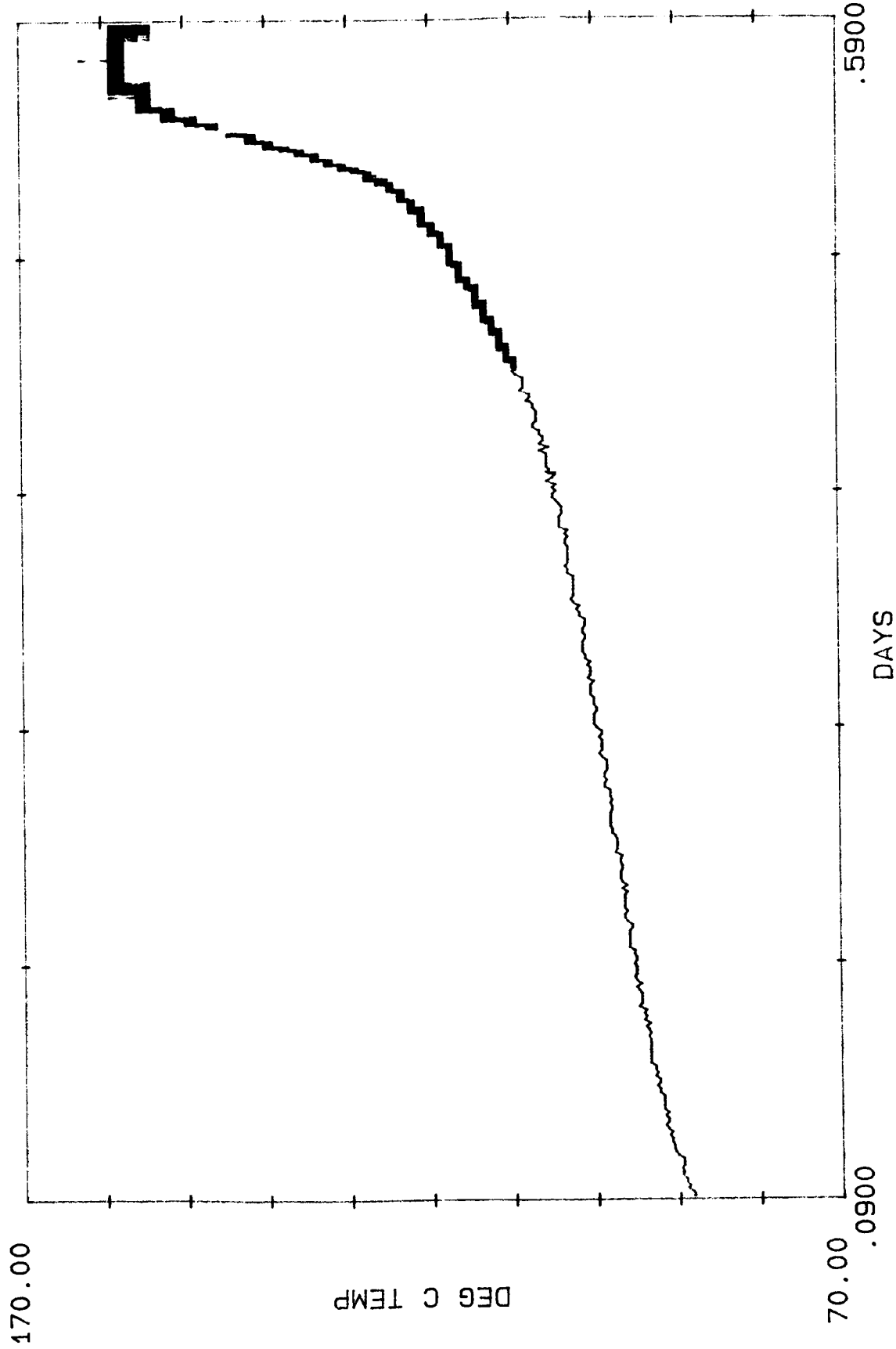

Temperature vs Time

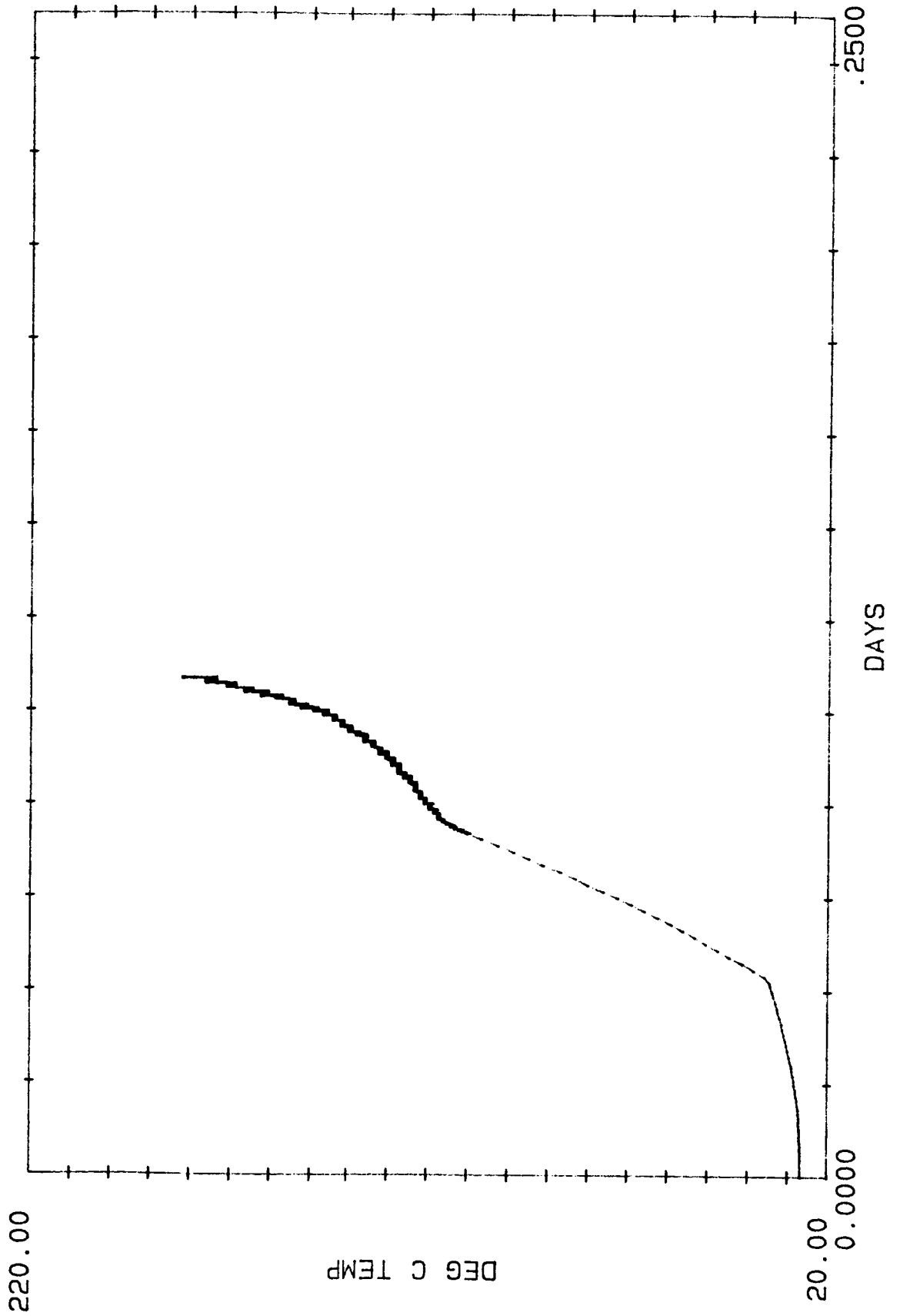

VUEGRAPH 12

Post—Explosion Photographs

A. CHAMBER INTERIOR



B. REMAINS OF 35 Ah CELL

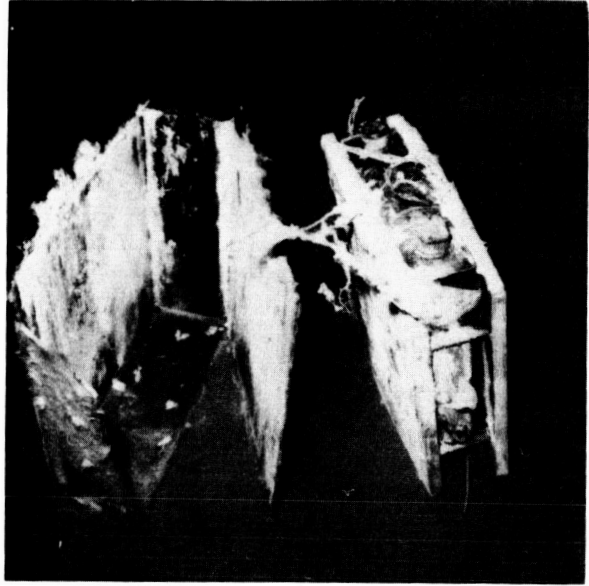

ORIGINAL PAGE IS
OF POOR QUALITY

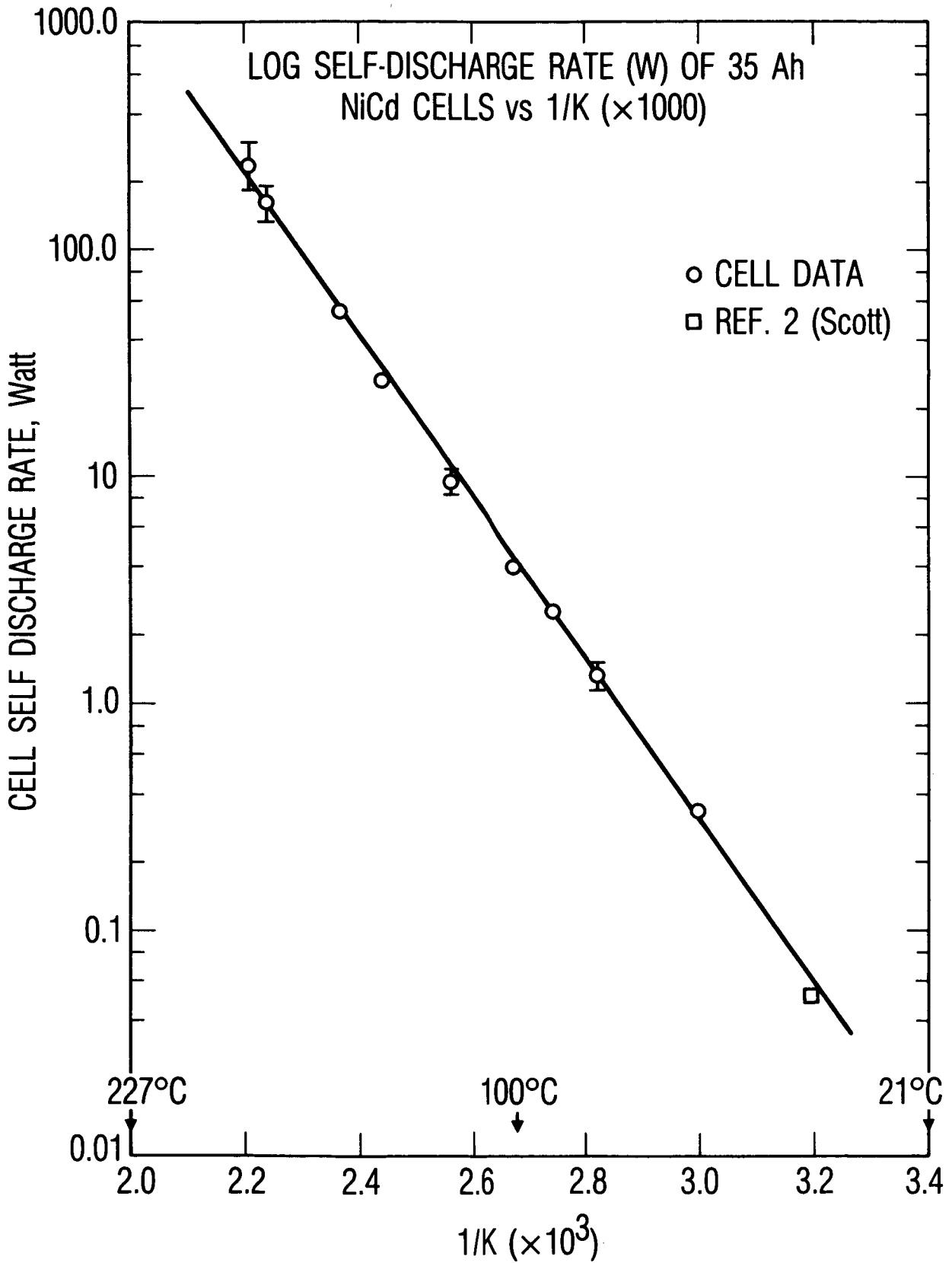

VUEGRAPH 14

CONCLUSIONS

- * THE HEAT GENERATED FROM SELF-DISCHARGE HAS NOW BEEN DETERMINED OVER A WIDE RANGE OF TEMPERATURES
- * THERMAL RUNAWAY CAN OCCUR FROM ELEVATED TEMPERATURE SELF-DISCHARGE
- * THERMAL RUNAWAY CAN BE FAST ENOUGH TO RUPTURE CELLS IN BATTERIES AND CAUSE PHYSICAL DAMAGE IN THE SURROUNDING AREA
- * TEMPERATURES OF A CHARGED BATTERY MUST BE LIMITED FOR SAFETY MEASURES EVEN ON OPEN CIRCUIT. THE MAXIMUM ALLOWABLE TEMPERATURE DEPENDS ON THERMAL MANAGEMENT. IN OUR CASE 80° C WAS THE UPPER LIMIT.