

PLENARY SESSIONS

N86 - 29352

SUMMARY OF PROCESS RESEARCH ANALYSIS EFFORTS

JET PROPULSION LABORATORY

Dale R. Burger

Introduction

- **Process design/cell design**
- **Cell efficiency drivers:**
 - **Bulk parameters and cell parameters**
 - **Tailored process sequences**
 - **New process options**
 - **Process control**
- **Lifetime improvement drivers:**
 - **Diffusion barriers**
 - **Encapsulation**

Process Design and Cell Design

- **Interactive effort**
- **Physics determines efficiency and sensitivity**
- **Research interest areas**
 - **Previous PV research (MIS)**
 - **IC processes (poly Si, light pulse)**
 - **Miscellaneous industries**
 - **Thick Film (MOD)**
 - **Ink-jet printing (MOD)**
 - **Magnetic memory (high-rate metallization)**

PLENARY SESSIONS

Cell Efficiency Drivers

- **Bulk parameters and cell parameters**
 - **Available bulk parameters**
 - **Cost and availability**
 - **Size**
 - **Retention and enhancement of parameters**
 - **Thermal history: precipitates, dislocation clusters, gettering**
 - **Contamination: environmental, handling, materials**
 - **Cell design**
 - **Design goal, not specification: -e.g., poly vs thin oxide**
 - **Cost vs performance**
 - **Life-cycle cost**
 - **Learning curve**
 - **Metallization system**

Tailored Process Sequences

- **Bulk material dependency**
 - **Cz**
 - **FZ**
 - **Web**
- **Shape-dependent**
- **Equipment-dependent**

New Process Options

- **Lasers**
- **Robotics**
- **Thermal pulse**
- **New materials**
 - **Polysilicon**
 - **MOD**

Process Control

- Yield Management = profits
- Low-cost data acquisition and analysis
- IEEE-488 compatibility
- Test patterns
 - Circular TLM
 - NBS-22 pattern (NBS 81-2260)
- Non-contacting testing
 - Thermo probe
 - X-ray photoemission spectrometry
 - FTIR
- Contact testing
 - 1/f noise

CTLM Test Patterns

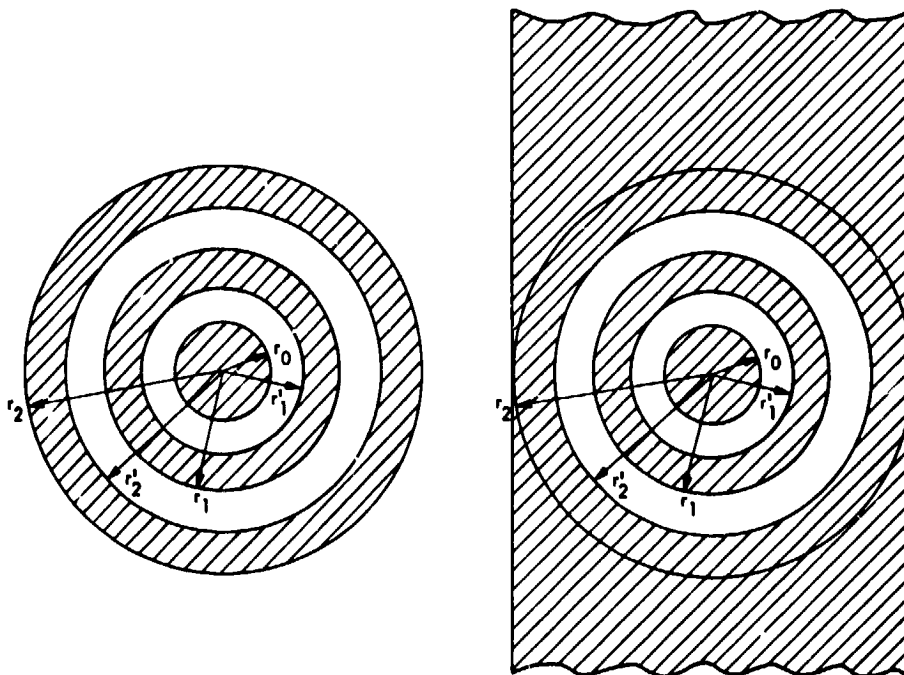

PLENARY SESSIONS

NBS-22 Solar-Cell Test Pattern

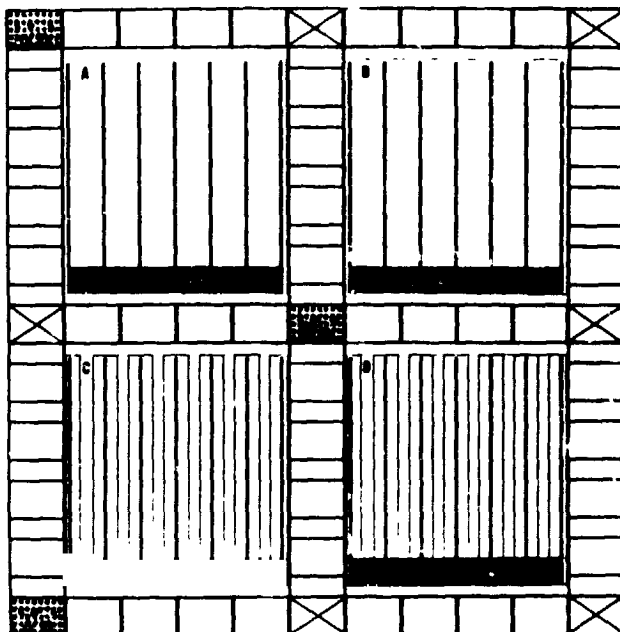

Reference Test Structures

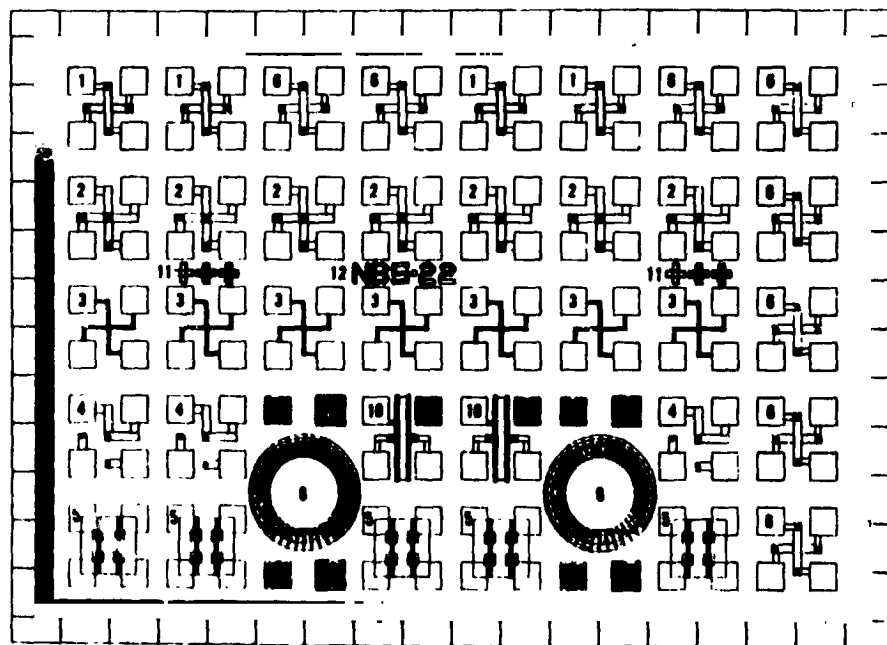

PLENARY SESSIONS

Lifetime Improvement Drivers

- **Diffusion barriers**
 - **Reduce rate of ambient thermal diffusion**
 - **Reduce rate of chemical activity**
- **Encapsulation**
 - **Provide environmental barrier**
 - **Provide circuit insulation**
 - **Low degradation rate**
 - **Should not enhance chemical activity**