

N86-17869

SPACE STATION POWER MANAGEMENT AND DISTRIBUTION

Fred Teren
 NASA Lewis Research Center
 Cleveland, Ohio

The power system architecture is presented by a series of schematics which illustrate the PMAD system at the component level, including converters, controllers, switchgear, rotary power transfer devices, power and data cables, remote power controllers, and load converters. Power distribution options, reference power management, and control strategy are also outlined. A summary of advanced development status and plans and an overview of system test plans are given.

TECHNOLOGY OPTIONS FOR FUTURE HIGH POWER AEROSPACE ELECTRIC SYSTEMS

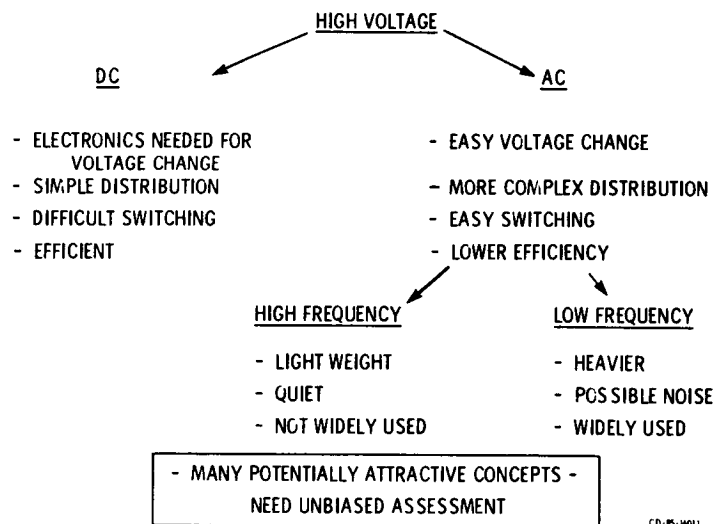

Figure 1.

REFERENCE PHOTOVOLTAIC POWER SYSTEM ARCHITECTURE

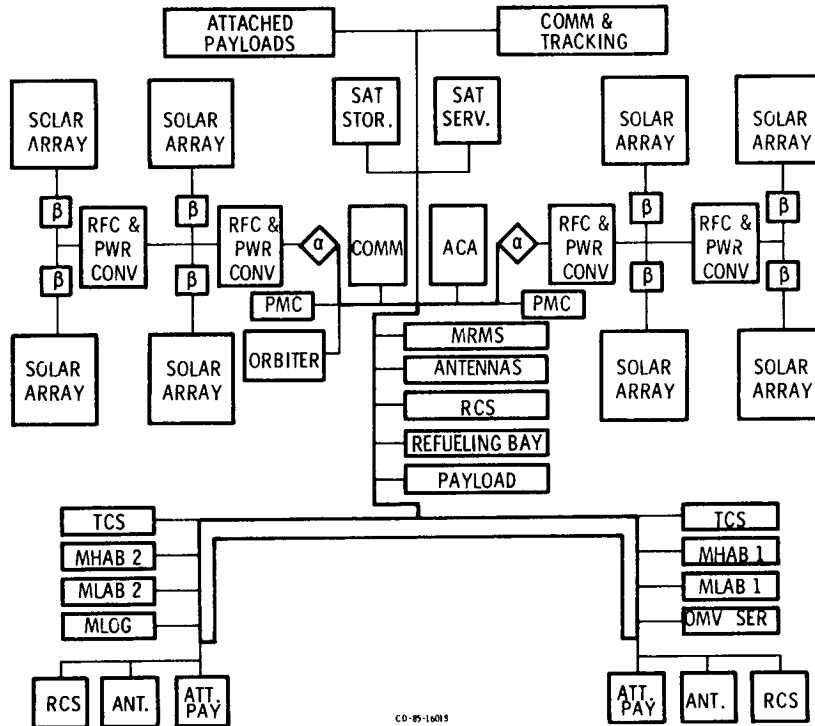

Figure 2.

REFERENCE PHOTOVOLTAIC POWER SYSTEM ARCHITECTURE

OUTBOARD TRANSVERSE BOOM

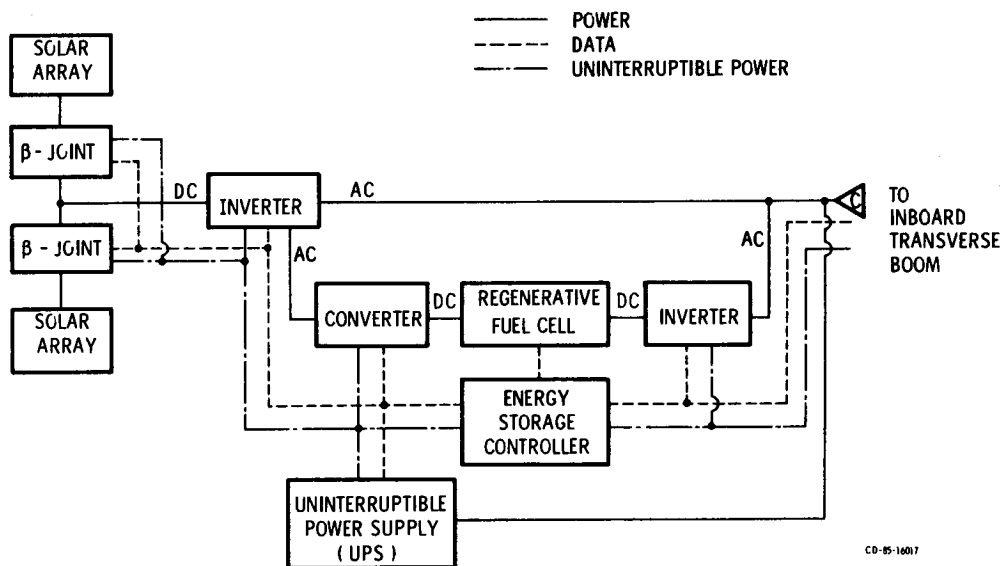

Figure 3.

REFERENCE PHOTOVOLTAIC POWER SYSTEM ARCHITECTURE
INBOARD TRANSVERSE BOOM

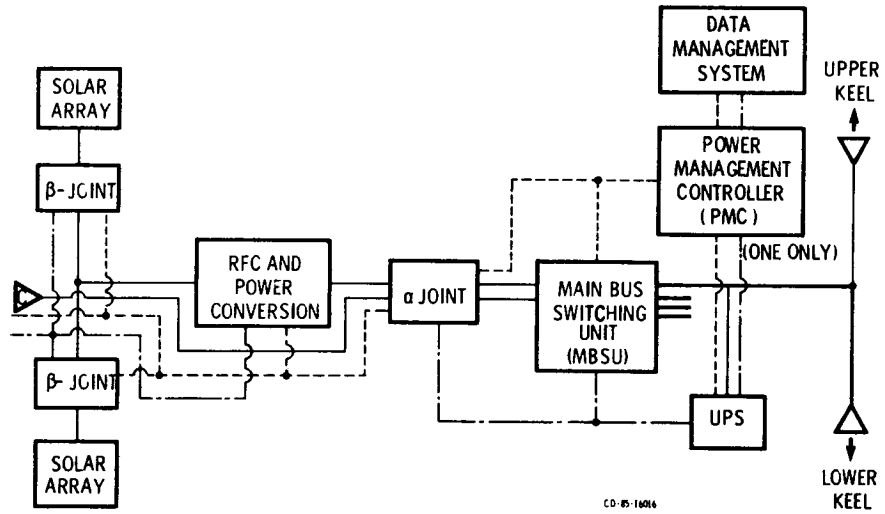

Figure 4.

REFERENCE PHOTOVOLTAIC SYSTEM ARCHITECTURE (LOWER BOOM)

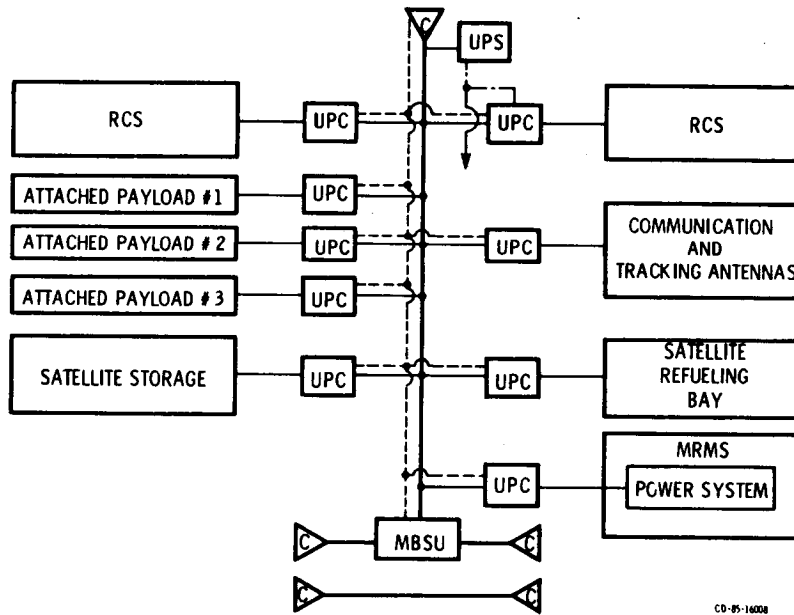

Figure 5.

REFERENCE PHOTOVOLTAIC POWER SYSTEM ARCHITECTURE
(STARBOARD KEEL EXTENSION AND LOWER BOOM)

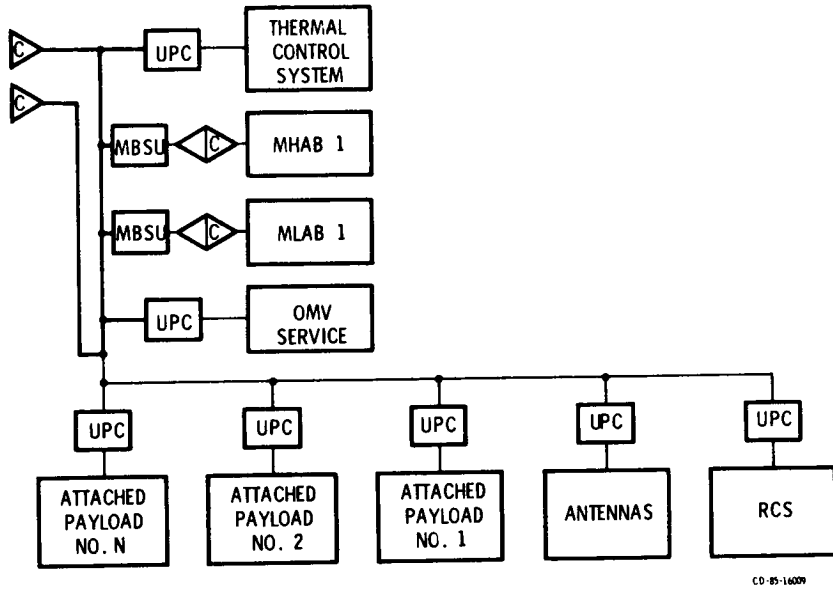

Figure 6.

REFERENCE PHOTOVOLTAIC POWER SYSTEM ARCHITECTURE
(MHAB NO. 1)

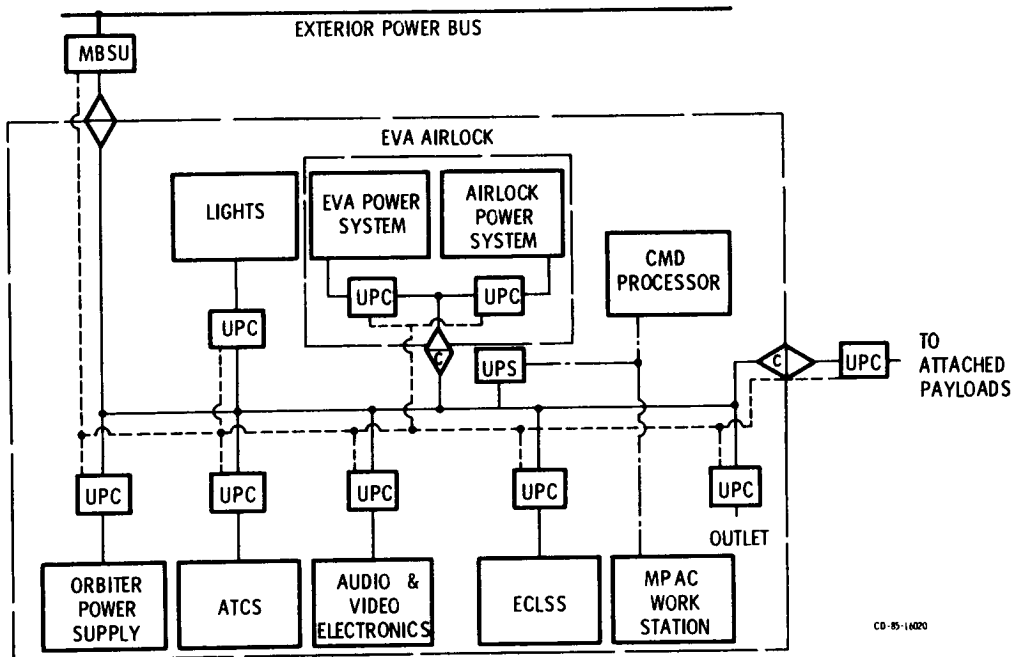

Figure 7.

REFERENCE SOLAR DYNAMIC POWER SYSTEM ARCHITECTURE
(INBOARD TRANSVERSE BOOM)

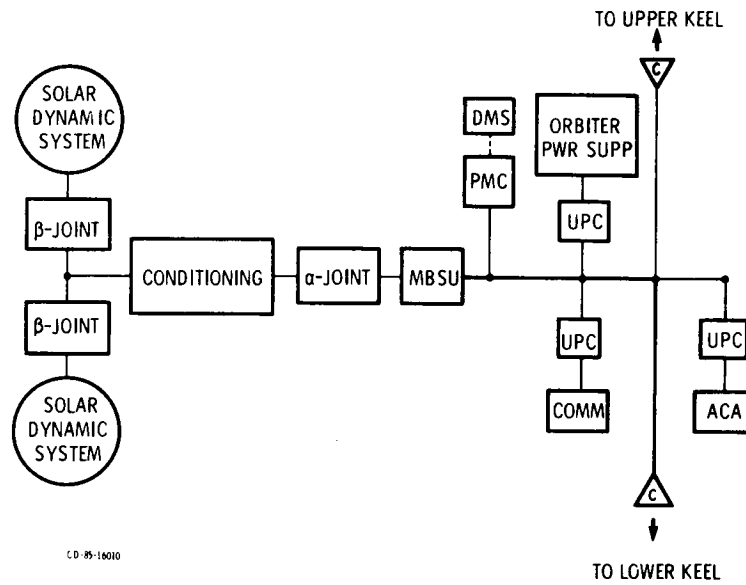

Figure 8.

ADVANCED DEVELOPMENT TASKS

- POWER COMPONENT AND SUBSYSTEM DEVELOPMENT
 - FUNCTIONAL AND LIFE TESTING
 - SYSTEM DEMONSTRATION
- POWER MANAGEMENT INTEGRATED CONTROL NETWORK
 - COMPUTER CONTROL HARDWARE
 - NETWORK CONTROL SCHEME
 - SYSTEM SOFTWARE
- POWER SYSTEM SIMULATION AND CONTROL
 - COMPONENT AND SYSTEM MODELS
 - REAL AND NON - REAL TIME SIMULATION
 - CONTROL ALGORITHMS
 - POWER MANAGEMENT ALGORITHMS
- POWER MANAGEMENT AND DISTRIBUTION SYSTEM DEMONSTRATIONS

CD-85-16013

Figure 9.

ADVANCED DEVELOPMENT

POWER COMPONENTS

- ROLL RINGS
- TRANSMISSION LINE
- AC POWER CONTROLLERS AND BUS ISOLATORS
- SEMI - CONDUCTOR PACKAGING
- DC SWITCHGEAR

POWER SYSTEM HARDWARE

- HIGH FREQUENCY (20KHZ) POWER SYSTEM
- HIGH EFFICIENCY CONVERTERS
- LOW FREQUENCY (400 Hz) POWER SYSTEM

POWER MANAGEMENT AND CONTROL

- NETWORK CONTROL SYSTEM
- SIMULATIONS
- CONTROL ALGORITHMS

CD-85-16012

Figure 10.



Figure 11.

LEWIS RESEARCH CENTER POWER SYSTEMS TEST FACILITY

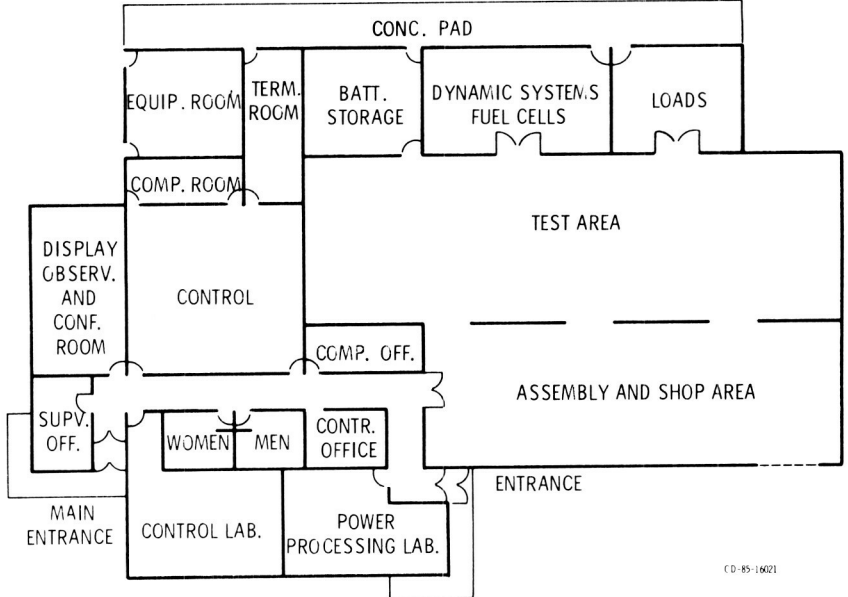

FLOOR PLAN
15,000 sq. ft.

Figure 12.

POWER SYSTEM DEMONSTRATION
SINGLE STRING 20 KHZ AC D-CONTROLLERS

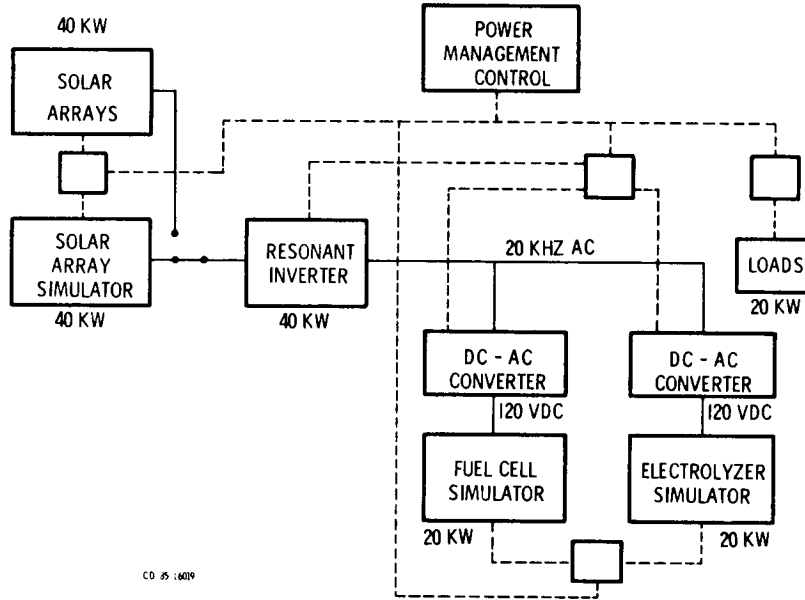

Figure 13.