

N86-11242

**NONDESTRUCTIVE ULTRASONIC MEASUREMENT OF BOLT PRELOAD USING
THE PULSED-PHASE LOCKED-LOOP INTERFEROMETER**

**S. G. Allison and J. S. Heyman
NASA Langley Research Center
Hampton, Virginia 23665**

ABSTRACT

Achieving accurate preload in threaded fasteners is an important and often critical problem which is encountered in nearly all sectors of government and industry. Conventional tensioning methods which rely on torque carry with them the disadvantage of requiring constant friction in the fastener in order to accurately correlate torque to preload. Since most of the applied torque typically overcomes friction rather than tensioning the fastener, small variations in friction can cause large variations in preload. An instrument called a pulsed-phase locked-loop interferometer, which was recently developed at NASA Langley, has found widespread use for measurement of stress as well as material properties. When used to measure bolt preload, this system detects changes in the fastener length and sound velocity which are independent of friction. The system is therefore capable of accurately establishing the correct change in bolt tension. This high-resolution instrument has been used for precision measurement of preload in critical fasteners for numerous applications such as the Space Shuttle landing gear and helicopter main rotors.

INTRODUCTION

Several years ago, NASA Langley Research Center began developing a technique for accurately measuring preload in threaded fasteners. As a result of this effort, today we have just such an instrument called a pulsed-phase locked-loop interferometer. This new measurement system offers a vast improvement over torque for meeting the objective of threaded fasteners, i.e., obtaining the desired amount of clamping force or preload holding an assembly together. The problem with the conventional torque approach for obtaining preload is that since most of the applied torque goes toward overcoming friction, large errors are caused by variations in friction. Conventional use of torque achieves preload accuracy of 20 percent at best, and it is not at all unusual to expect an accuracy of only 50 percent or even worse using torque to measure bolt preload. The solution is to measure stress, not torque. The pulsed-phase locked-loop system ultrasonically measures bolt "stretch" without measuring friction. With this new system, bolt preload can be measured with accuracies ranging from better than 1 percent for good geometry bolts to approximately 3 percent for fasteners having poor geometry and with measurement resolution of 1 psi.

This report describes some basic problems associated with the conventional use of torque for bolt preload measurements and shows data illustrating the improvements obtainable with some ultrasonic techniques. The report gives background information about previous instruments which led to development of the current pulsed-phase locked-loop system and discusses some of the earlier limitations which have been eliminated by the current state-of-the-art system. The present pulsed-phase locked-loop system is described giving examples of bolt preload measurement applications as well as describing other capabilities of this versatile measurement instrument.

ULTRASONIC BOLT MEASUREMENTS

$$F_j = \frac{V}{A}$$

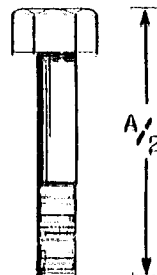
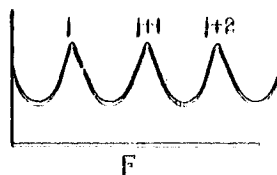

$$\Delta F_j = \frac{V}{A} \left(\frac{1}{V} \frac{dV}{dA} - \frac{1}{A} \right) \Delta A$$

$$\Delta F_j = F_j \left[\frac{1}{V} \frac{dV}{dS} - \frac{1}{E} \right] \Delta S$$

$$\frac{dV}{dS} = \frac{-1}{6\rho(\lambda + 2\mu/3)V} \left[2\lambda + \lambda + \frac{\lambda + \mu}{\mu} (4m + 4\lambda + 10\mu) \right]$$

EXAMPLE FOR MILD STEEL

$$\Delta F = 0.632 \Delta S \text{ (POUNDS/IN.}^2\text{) AT 5MHz}$$

In order to illustrate how bolt preload can be measured ultrasonically, an analogy can be made to the pipe organ. A pipe organ uses pipes of different lengths so that each pipe has a different resonance frequency in accordance with its length. If one of these pipes was to be made slightly longer or shorter, and if the sound velocity of the gas in the pipe was changed, the resonance frequency would shift in proportion to the change in length and gas sound speed. In a similar manner, continuous wave (CW) type bolt monitors use the bolt as an ultrasonic resonator (like the organ pipe). An ultrasonic transducer is placed on the end of the bolt producing sound waves within the bolt. The insonified bolt typically has several resonance frequencies (see Fig. above), i.e., the fundamental plus a number of harmonics which are integral multiples of the fundamental. When the bolt is tightened, the length and sound velocity changes cause a proportional change in resonance frequency. By tracking the resonance frequency changes, the bolt monitor is also tracking stress (preload) changes since the change in resonance frequency is equal to a constant times the change in stress.

INTRODUCTION TO THE MEASUREMENT SYSTEMS

EVOLUTION OF NASA BOLT MONITOR

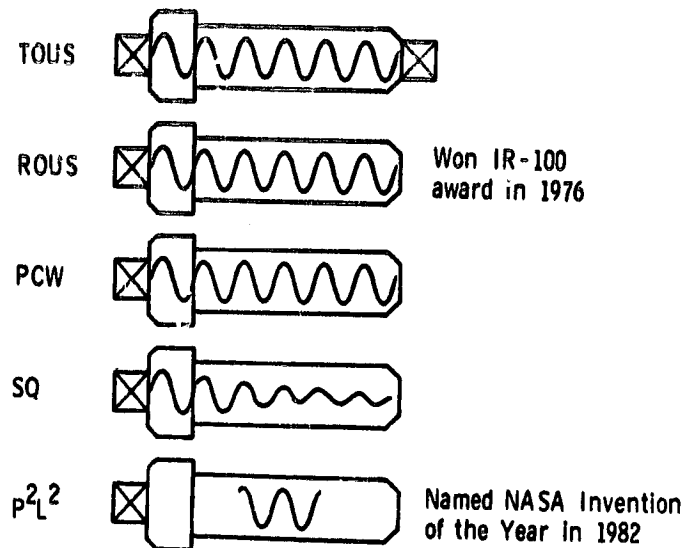

The pulsed-phase locked-loop (P^2L^2) system evolved from several predecessors including the transmission oscillator ultrasonic spectrometer (TOUS), the reflection oscillator ultrasonic spectrometer (ROUS), the pseudo-continuous wave (PCW) system and the spoiled Q (SQ) system. Each predecessor to the P^2L^2 offered great improvement over the conventional torque method but also had some special requirements. For example, the CW TOUS (Ref. 1) could measure bolt preload with great precision but required the use of a transducer at each end of the bolt and also required bolt preparation, i.e., machining of the bolt ends to be smooth, flat and parallel. The CW ROUS system (Ref. 2), which won an IR-100 Award in 1976, also measured preload with great precision and offered the additional advantage of requiring the use of only one transducer so that access to only one end of the bolt was required. The ROUS, however, still required bolt end preparation and also required use of a special complex transducer that could continuously transmit and receive signals simultaneously. The PCW system (Ref. 3) eliminated the need for a complex transducer but still required bolt preparation. In addition, the PCW began to move away from a pure CW system. The SQ system moved further away from a pure CW concept and eliminated the requirement for bolt preparation, but, in doing so, it sacrificed the ability to make bolt preload measurements with the degree of precision achieved by previous bolt monitors. Finally, the P^2L^2 system (Ref. 4) eliminated all of the special requirements, i.e., it provided a means of measuring bolt preload with great precision (parts in 10^7) using one simple transducer and without requiring any bolt preparation. The P^2L^2 was named NASA Invention of the Year in 1982 and has been used to verify bolt preload in a number of critical applications. It is neither CW or broadband pulsed. Instead, it is between a frequency domain instrument and a time domain instrument.

MEASUREMENT SYSTEM DETAILS

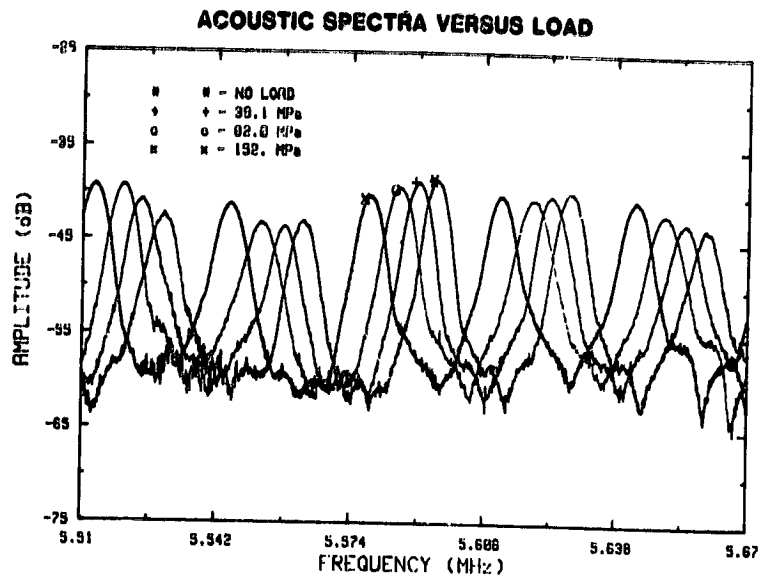
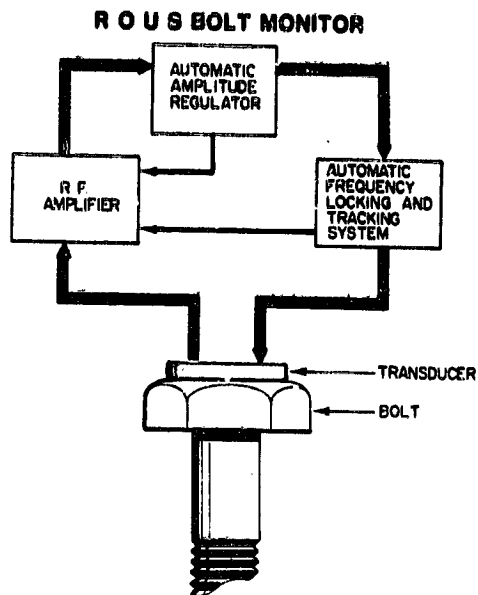

The ROUS system, as previously mentioned, uses a complex transducer acoustically coupled to the bolt to transmit and receive ultrasonic waves. The electronics system incorporates a special marginal oscillator which uses resonance feedback from the bolt to track stress-induced resonance frequency changes. By examining the above typical acoustic spectral response of a bolt at different preload levels, one can see that tightening of the bolt causes the resonance frequency to shift. The ROUS bolt monitor measures these stress-induced changes in bolt resonance frequency with a high degree of accuracy.

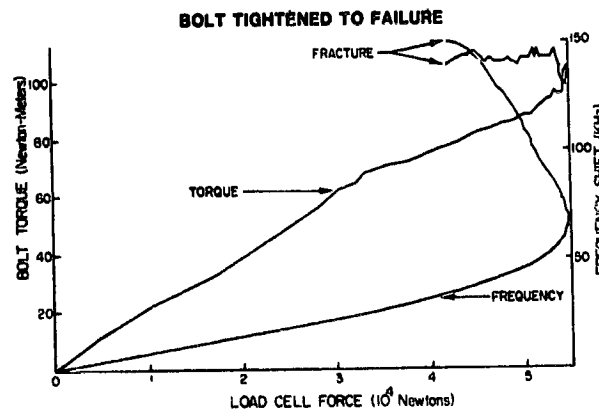
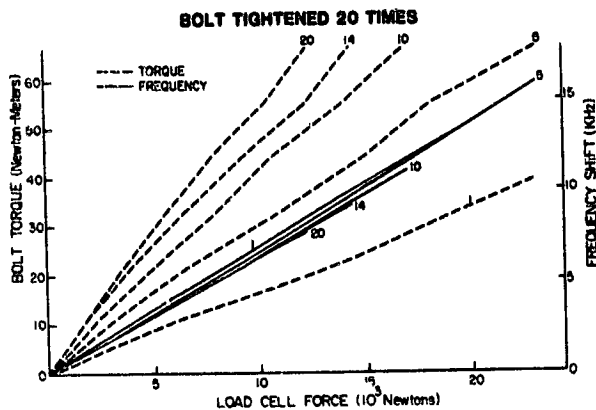
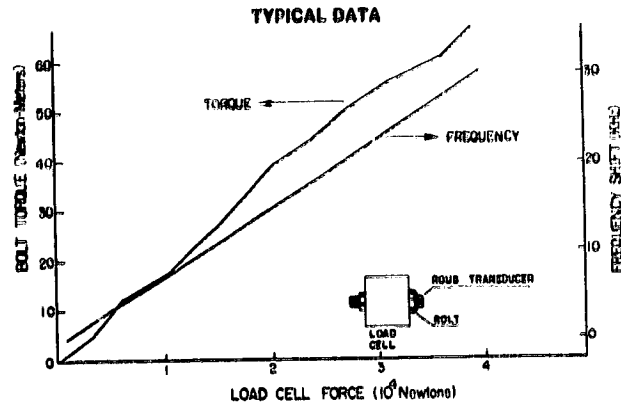
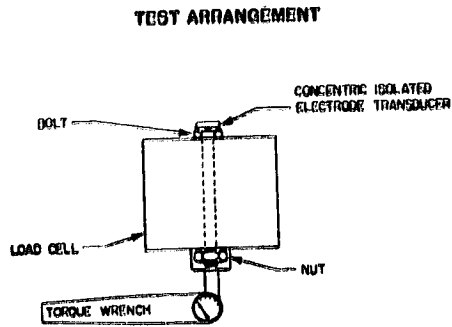

In order to show the relationship between actual bolt preload, applied tightening torque, and acoustic resonance frequency, the test arrangement shown in the top left figure above is used. In this arrangement, a bolt is placed through a load cell and a torque wrench is used to tighten the bolt to a known load level. A ROUS system measures stress-induced resonance frequency shifts in the bolt. Typical torque and frequency shift data are shown in the top right figure as a function of load cell force. This illustrates that frequency is much more directly related to bolt preload than is torque.

In the lower left figure, data for a bolt tightened 20 times illustrate that use of torque can result in large variations in bolt preload. In this case, retightening of a bolt 20 times results in a 70% change in bolt preload. Note that the ultrasonic data consistently track bolt preload regardless of changes in friction. The slight change in slope of the ultrasonic data is due to a small change in load length resulting from yielding of the fastener threads. In the lower right figure a bolt is tightened to failure showing that the ultrasonic frequency data track bolt stress all the way to fracture. One can see from this that the ultrasonic system can even be used to detect yielding of the fastener since the ultrasonic frequency will continue to increase after the applied torque stops increasing.

P²L² MEASUREMENT SYSTEM

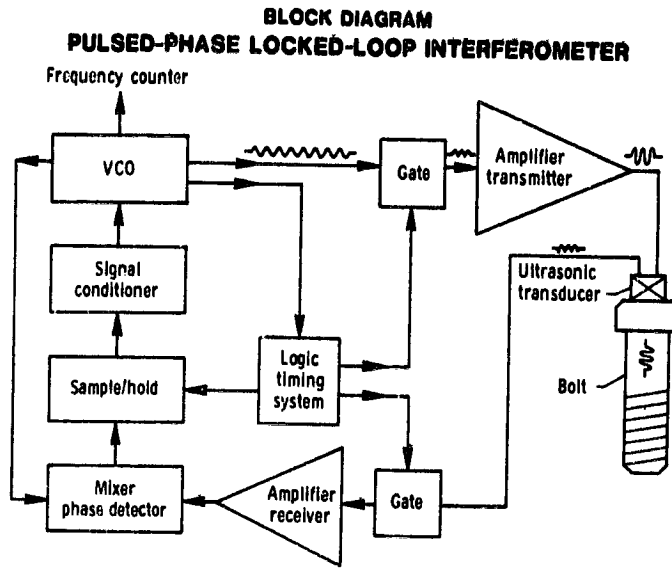

THEORY OF OPERATION

TIME DOMAIN

$$T = \frac{L}{V} \quad (T = 2 \text{ way propagation time})$$

$$\frac{dT}{d\sigma} = \frac{1}{V} \left[\frac{\partial L}{\partial \sigma} - \frac{L}{V^2} \frac{\partial V}{\partial \sigma} \right]$$

$$\frac{dT}{d\sigma} = T \left[\frac{1}{L} \frac{\partial L}{\partial \sigma} - \frac{1}{V} \frac{\partial V}{\partial \sigma} \right]$$

$$\frac{dT}{T} = \left[\frac{1}{L} \frac{\partial L}{\partial \sigma} - \frac{1}{V} \frac{\partial V}{\partial \sigma} \right] d\sigma$$

$$\frac{\Delta T}{T} = \left(\frac{\Delta L}{L} - \frac{\Delta V}{V} \right)$$

FREQUENCY DOMAIN

$$\phi = 2\pi F T$$

$$\frac{d\phi}{d\sigma} = 2\pi \left[F \frac{\partial T}{\partial \sigma} + T \frac{\partial F}{\partial \sigma} \right] \equiv 0$$

$$F \frac{\partial T}{\partial \sigma} = -T \frac{\partial F}{\partial \sigma}$$

$$\frac{\Delta F}{F} = -\frac{\Delta T}{T}$$

$$\frac{\Delta F}{F} = \left(\frac{\Delta V}{V} - \frac{\Delta L}{L} \right)$$

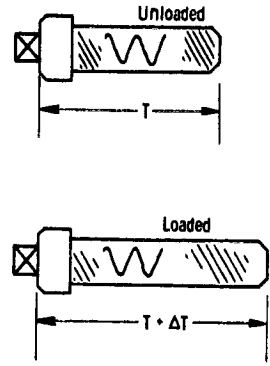

The P²L² system is the state-of-the-art instrument offering high resolution without the limitations of previous bolt monitors. The P²L² shown in the above block diagram uses a voltage-controlled oscillator (VCO) and gate to send out an electronic pulse consisting of a few cycles of RF energy to drive an ultrasonic transducer. This produces an acoustic tone burst or sound wave pulse that travels down the length of the bolt and bounces off of the far end. The returning echo produces an electronic signal that is received back into the P²L², is amplified and goes to a phase detector. The phase detector compares the phase of the received signal to that of the signal that went out, generates a voltage proportional to the difference in phase, and (when the instrument is locked) changes the frequency of the VCO such that the phase of the signal out is held constant with respect to the phase of the signal in. With this arrangement, a change in acoustic phase in the bolt causes a corresponding change in output frequency of the P²L² system. Therefore, when we preload the bolt we change the acoustic pathlength as well as the velocity of sound and cause a change in the output frequency of the P²L².

The P^2L^2 system is actually measuring small changes in acoustic propagation time in the bolt. The right-hand figure on the preceding page shows a bolt in the unloaded and loaded configurations. Before loading, the pulse propagation time (or time of flight) is T whereas after preloading the propagation time becomes $T + \Delta T$. This small change in propagation time, ΔT , can be measured in the time domain or in the frequency domain. In the time domain, the time of flight is the acoustic pathlength, L , divided by the velocity of sound, V . If we take the derivative of T with respect to stress, we obtain an expression containing stress-induced length and velocity changes. This expression simplifies to show that a change in propagation time is proportional to a material strain and an ultrasonic velocity change. Time domain measurements involve thresholds, noise, amplitude variations and complex propagation laws. Of course, the P^2L^2 instrument is more of a phase velocity device which is not subjected to the group velocity constraints of a time domain device. Because of inaccuracies inherently associated with measuring in the time domain, the P^2L^2 system was developed to measure in the frequency domain in which stress-induced acoustic phase shifts can be measured with great precision. Since the acoustic phase, ϕ , is a function of acoustic frequency, F , and propagation time, T , the derivative of the phase with respect to stress is a function of the stress-induced changes of propagation time and frequency as shown on the preceding page. Since our P^2L^2 system maintains constant phase, the stress derivative of the acoustic phase is forced to equal zero. The above expression then simplifies to show that the stress-induced frequency shift measured by the P^2L^2 is directly related to the small stress-induced change in ultrasonic pulse propagation time. This can be rewritten to show that the stress-induced frequency shift is proportional to a stress-induced strain and a stress-induced velocity change.

ORIGINAL PAGE IS
OF POOR QUALITY

TYPICAL CRITICAL FASTENERS

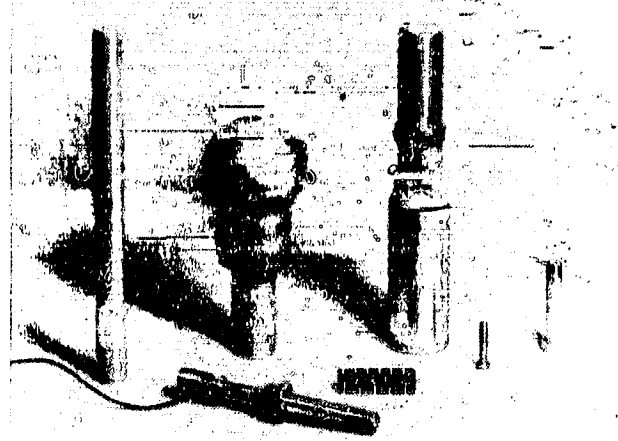

NTF TURBINE ROTOR BLADE BOLTS

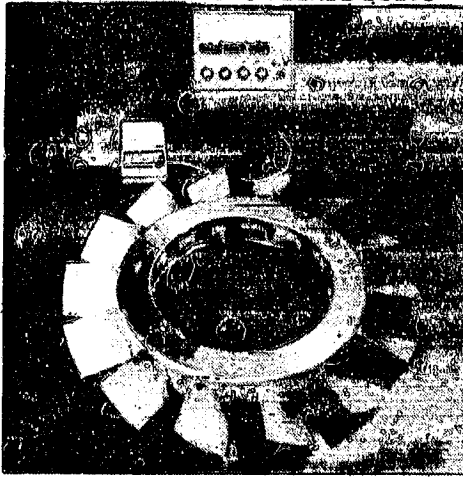

SILTS SAFETY DOME BOLTS



Some typical critical fasteners for which preload was verified using the P^2L^2 are shown in the upper figure. The bolt shaped like a trailer hitch ball holds an external solid-rocket booster onto the Delta Launch Vehicle. The large fastener to the right holds the front of the Space Shuttle orbiter to the external fuel tank. Other bolts shown include a Space Shuttle landing gear wheel bolt, a Shuttle Infrared Leaside Temperature Sensor (SILTS) bolt and a typical aircraft bolt. Also shown is a typical test sample rod used for experimental work.

The bottom left figure shows preload verification for critical fasteners holding blades on a scaled turbine rotor for the National Transonic Cryogenic Wind Tunnel Facility (NTF) at NASA Langley. The lower right figure shows preload measurements being made for the SILTS safety dome bolts. These fasteners are critical to the safety of the Space Shuttle since the safety dome prevents combustible hydrazine from coming into contact with possible ignition sources within the SILTS electronics.

ORIGINAL PAGE IS
OF POOR QUALITY

MINE SAFETY ROOF BOLTS

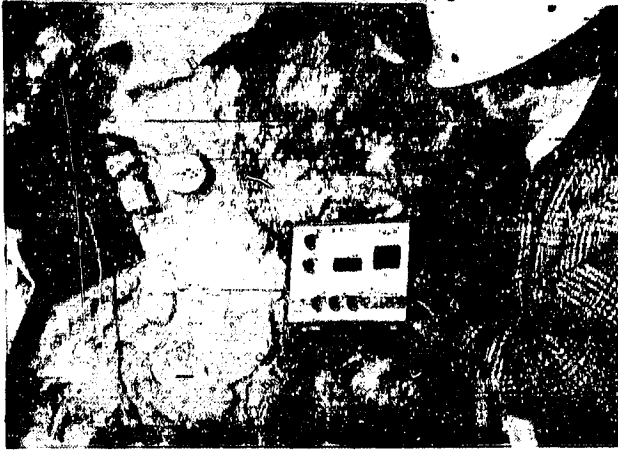

9/16 INCH MINE BOLT

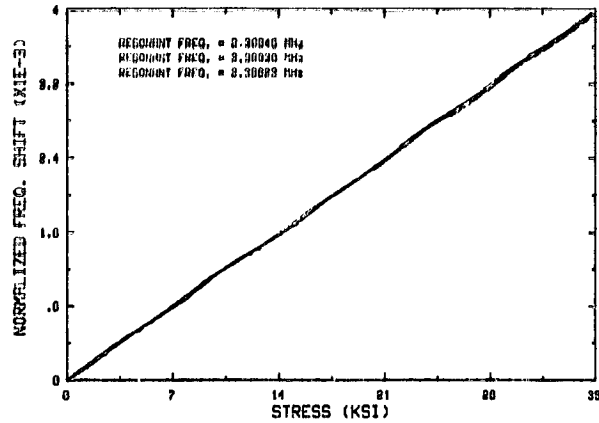

TYPICAL STAMPED AIRCRAFT BOLT

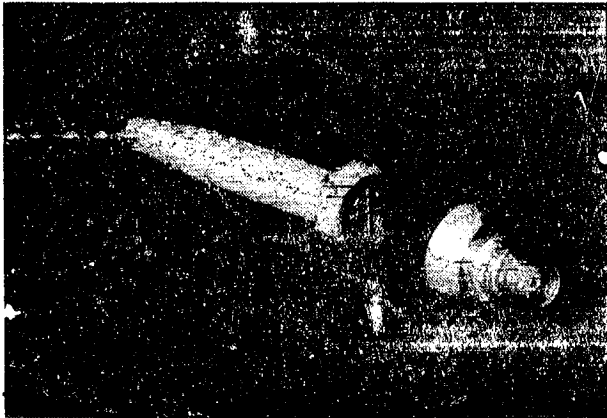

1/2 INCH STAMPED BOLT

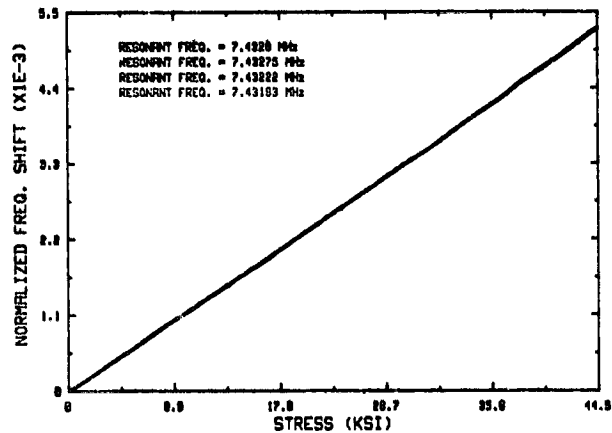

Preload measurements were made for mine safety roof bolts which perform the critical function of keeping the roof rock material under compressive stress to prevent cave-ins. Typical frequency versus stress data for three tightening cycles of a 6-foot-long roof bolt shows that the data are very linear and repeatable. As previously mentioned, the P^2L^2 system can even measure preload accurately for poor geometry fasteners. Even though the typical stamped aircraft bolt shown above has raised markings on the head and a safety wire hole at the end, stress versus frequency data obtained during four tightening cycles is seen to be very linear and repeatable.

P²L² IN PORTABLE CARRYING CASE

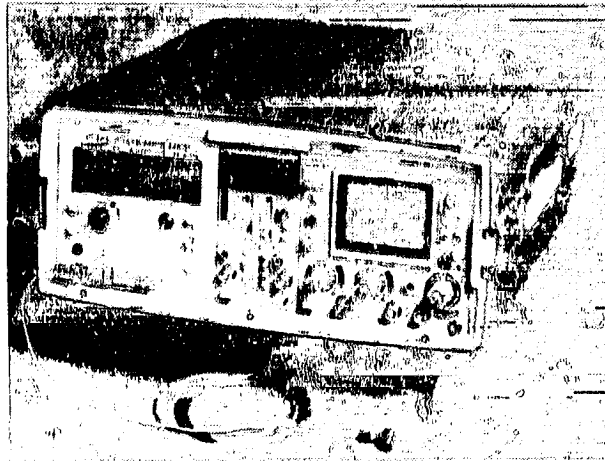

ARMY HELICOPTER CRITICAL MAIN ROTOR BOLTS



AH-64 HELICOPTER 27% ROTOR

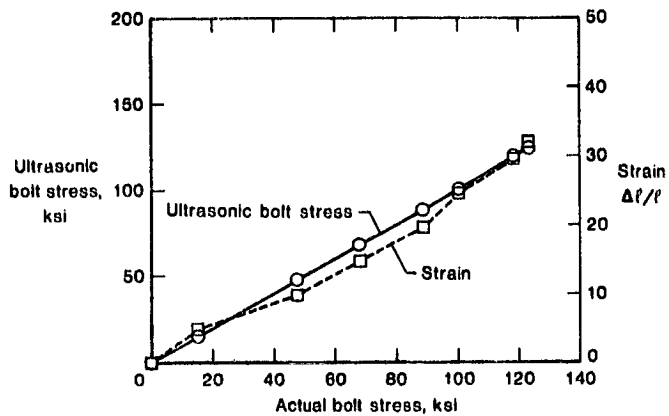

The latest state-of-the-art P²L² system is packaged in a carrying case the size of a small suitcase. This system can be carried into the field for performing preload measurements such as those made for the Army AH-64 helicopter main rotor bolts. Actual bolt stress versus strain and ultrasonic P²L² frequency data shows that the P²L² gives an even better indication of bolt stress than does strain measured with a micrometer.

ORIGINAL PAGE IS
OF POOR QUALITY

WIND TUNNEL NOZZLE PLATES

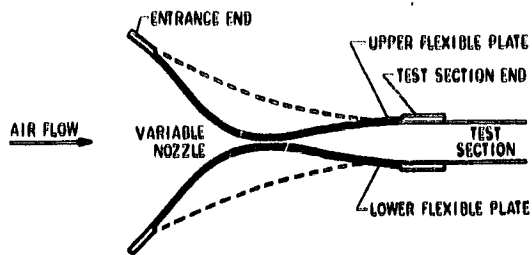

STRESS MEASUREMENTS FOR TUNNEL NOZZLE PLATES

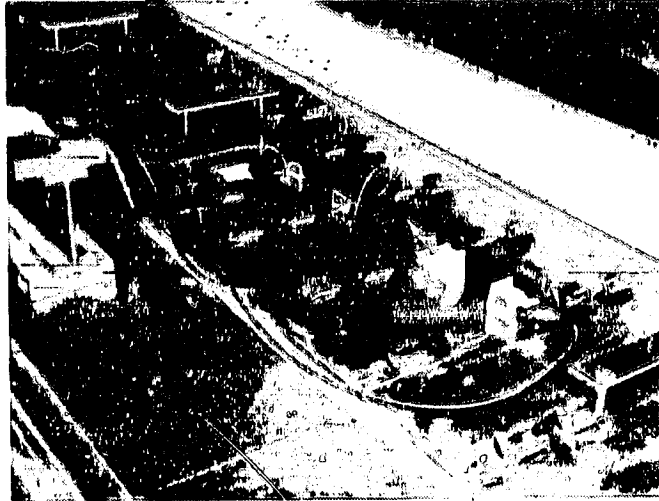

STRESS MEASUREMENTS FOR ROCK SAMPLE

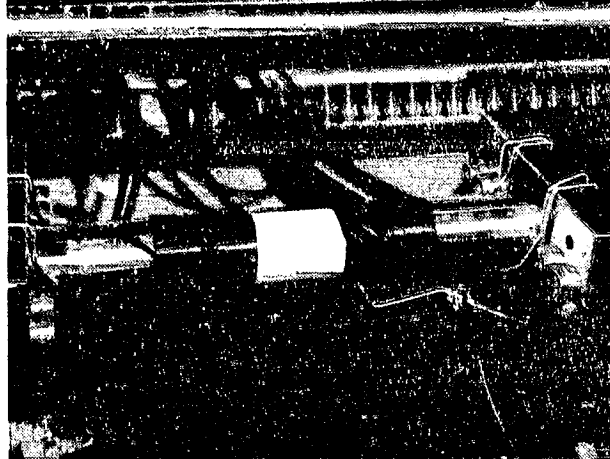

As previously pointed out, the P^2L^2 system has found widespread use for measurements other than bolt preload. For example, this system was used to measure stress in two flexible steel plates (Ref. 5) which comprise the variable nozzle of a critical NASA wind tunnel. The P^2L^2 measured plate stress changes using transducers (top right Fig.) to send and receive sound waves across the plate surface. The P^2L^2 system has even been used to measure stress changes in rock as can be seen in the bottom figure in which a rock sample is compressively stressed with a hydraulic loading machine with transducers (hidden from view) sending sound waves through the rock sample. The P^2L^2 also measures material properties and has been used for a number of material studies (Refs. 6, 7, and 8).

CONCLUDING REMARKS

In conclusion, ultrasonic techniques provide an excellent means to measure changes in bolt preload and to reverify bolt preload. Conventional techniques which rely on torque are very inaccurate because they measure friction which can vary to a great extent. The pulsed-phase locked-loop system measures bolt preload with accuracies ranging from better than 1% for prepared (good geometry) bolts to about 3% for poor geometry bolts. Use of the p^2L^2 system eliminates the need for costly alternatives such as strain gauge bolts and is suitable for a small portable instrument. Reliability of this system to make accurate bolt preload measurements has been demonstrated through a number of critical aerospace and other field applications within both the government and private sector. In addition to measurement of bolt preload, the pulsed-phase locked-loop system has been successfully used to measure stresses in a variety of other components including wind tunnel nozzle plates. This technique has also expanded materials characterization to include measurement of higher order (nonlinear) elastic material properties.

REFERENCES

1. M. S. Conradi, J. G. Miller, and J. S. Heyman: "A Transmission Oscillator Ultrasonic Spectrometer," Rev. Sci. Instrum., Vol. 45, No. 3, (March 1974).
2. J. S. Heyman: "A CW Ultrasonic Bolt Strain Monitor," Exp. Mech., Vol. 17, pp. 183-187 (1977).
3. J. S. Heyman: "Pseudo Continuous Wave Instrument," United States Patent #4,117,731 (1978).
4. J. S. Heyman: "Pulsed Phase Locked Loop Strain Monitor," NASA Patent Disclosure LAR-12772-1 (1980).
5. S. G. Allison, J. S. Heyman, and K. Salama, "Ultrasonic Measurement of Residual Deformation Stress in Thin Metal Plates Using Surface Acoustic Waves," Proceedings, 1983 IEEE Ultrasonic Symposium, Atlanta, GA.
6. J. S. Heyman and E. J. Chern: "Characterization of Heat Treatment in Aluminum Based on Ultrasonic Determination of the Second and Third Order Elastic Constants," Proceedings, 1981 IEEE Ultrasonic Symposium, Chicago, IL.
7. J. S. Heyman, S. G. Allison, and K. Salama: "Influence of Carbon Content on Higher-Order Ultrasonic Properties in Steels," Proceedings, 1983 IEEE Ultrasonic Symposium, Atlanta, GA.
8. S. G. Allison, J. S. Heyman, K. Smith, and K. Salama: "Effect of Prestrain Upon Acoustoelastic Properties of Carbon Steel," Proceedings, 1984 IEEE Ultrasonic Symposium, Dallas, TX.