

EXPLOSIVE WELDING OF TUBULAR CONFIGURED JOINTS FOR CRITICAL APPLICATIONS

Roy Hardwick
Explosive Fabricators, Inc.
Louisville, Colorado 80027

ABSTRACT

Explosive welding can provide the answer to problems of permanently joining metals typically used in the aerospace industry.

The explosive bonding process is a solid state bonding process enabling material incompatibility problems associated with fusion welding to be overcome. In addition, heat affected zones are eliminated thus enhancing joint strength, properties and performance.

The process requires the parts being joined to be impelled, by means of explosives, to collide with each other. Certain critical collision parameters must be met and controlled and these parameters are defined. Various component geometries which satisfy the collision parameters are described.

Examples of transition joints used in the aerospace industry are described and illustrated.

INTRODUCTION

Metallic components used in the aerospace industry are often required to be permanently joined together. The materials of construction, however, are quite varied and are often incompatible for fusion welding. In demanding environmental situations of thermal or fatigue cycling, it may also be desirable to avoid the use of fusion welded joints because of their inherent strength limitations. These limitations are associated with the cast structure and heat affected zones of the fusion weld.

Explosive welding can provide an answer when fusion welding should or must be avoided.

Explosive welding has been used primarily for the construction of flat plate clads and much of the technology is derived from this source. A second common application of the technology is the explosive welding of heat exchanger tube/tubeplate joints. Such joints are tubular in section. The combination of these two technologies permits methods of producing tubular transition or coupling joints to be devised. Such tubular configured joints represent a large number of metal joining requirements in the aerospace industry.

The unique welding mechanism and weld properties make the explosive welding process extremely useful for aerospace applications.

- a) Unlike fusion welded joints, the weld area can be several times the tubular wall thickness.
- b) The joint is stronger than the parent metal.
- c) Being a solid state bonding process, dissimilar metals of widely differing melting points can be welded.
- d) Metal combinations which cannot be fusion welded due to the formation of brittle intermetallics can be welded by explosive welding techniques.
- e) There is no cast structure within the joint, nor are there any heat affected zones.
- f) There is no dilution of the alloys at the interface.

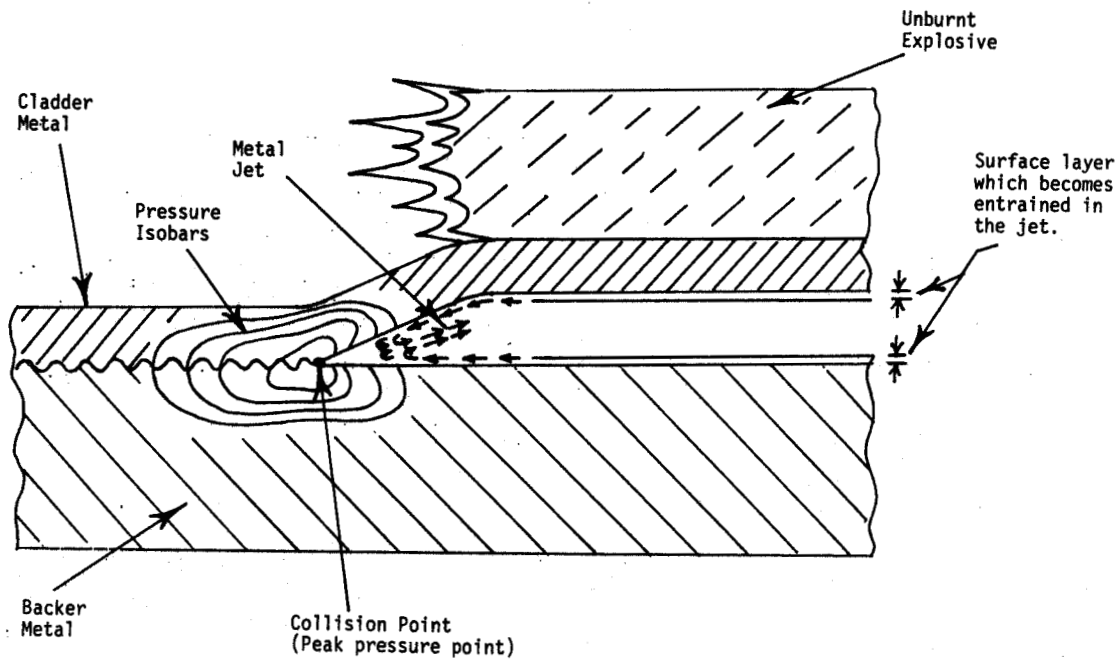

FIGURE 1

g) No filler metals are required.

h) Once the correct welding parameters are established, the process is highly reproducible given reasonable levels of quality control.

Because of these numerous advantages, an increased level of interest is being shown by the aerospace industry in producing explosively welded joints.

FUNDAMENTAL REQUIREMENTS FOR EXPLOSIVE WELDING

Explosive welding requires certain geometrical dispositions of the component parts to be joined. This is because the parts must be thrust together by the explosion, during welding, to cause collision of the parts in a very precise and controlled manner. These collision parameters, though critical, are highly reproducible and are as follows:

a) The two surfaces to be joined must be brought together progressively over their surface area. This will produce a collision front which traverses the two surfaces (Figure 1).

b) The collision front must travel at a velocity below the sonic velocity of the materials being joined. This will allow the associated pressure front to precede the collision front. As a result, the two approaching metal surfaces are subjected to an increasing pressure, culminating at a peak pressure on impact at the collision front.

c) The peak pressure at the collision front must significantly exceed the yield strength of the materials being joined. Plastic deformation of the component surfaces will then occur.

Provided the above requirements are met, the plastically deformed surfaces are projected forward into the lower pressure area of the interfacial gap ahead of the collision front. A jet is thus formed from the component surfaces which includes the surface oxides and other surface contaminants originally present. This jet precedes the collision front to be finally ejected from the interfacial gap. By this mechanism the surface contaminants are removed ahead of the collision front allowing the cleaned surfaces to be brought together in the solid state and under pressure. A bond is then formed due to inter-atomic attraction, or electron sharing, at the interface.

The depth of surface removed into the jet is a function of collision pressure; the greater the pressure, the greater the layer depth removed. The collision pressure is itself a function of cladder momentum and, as such, the controlling variable is the explosive load. It is desirable to minimize the explosive load for several reasons and consequently the level of contamination upon the surfaces prior to welding must be minimized to ensure it is fully removed into the jet. Similarly the surface topography must be closely controlled to ensure surface imperfections and machining marks are minimized to a degree where they also are within the layer depth removed by the jet. In practice, the surfaces to be bonded are machined or ground to specified standards of surface finish which are closely monitored. Degreasing of the surfaces is also a standardized procedure prior to assembly of the parts.

ALTERNATIVE METHODS OF EXPLOSIVE WELDING

The fundamental requirements of explosive welding described above are usually achieved by two alternative methods. There are others, but their limitations result in their less frequent use. The two principal set-ups are:

The parallel geometry, and
The angular geometry.

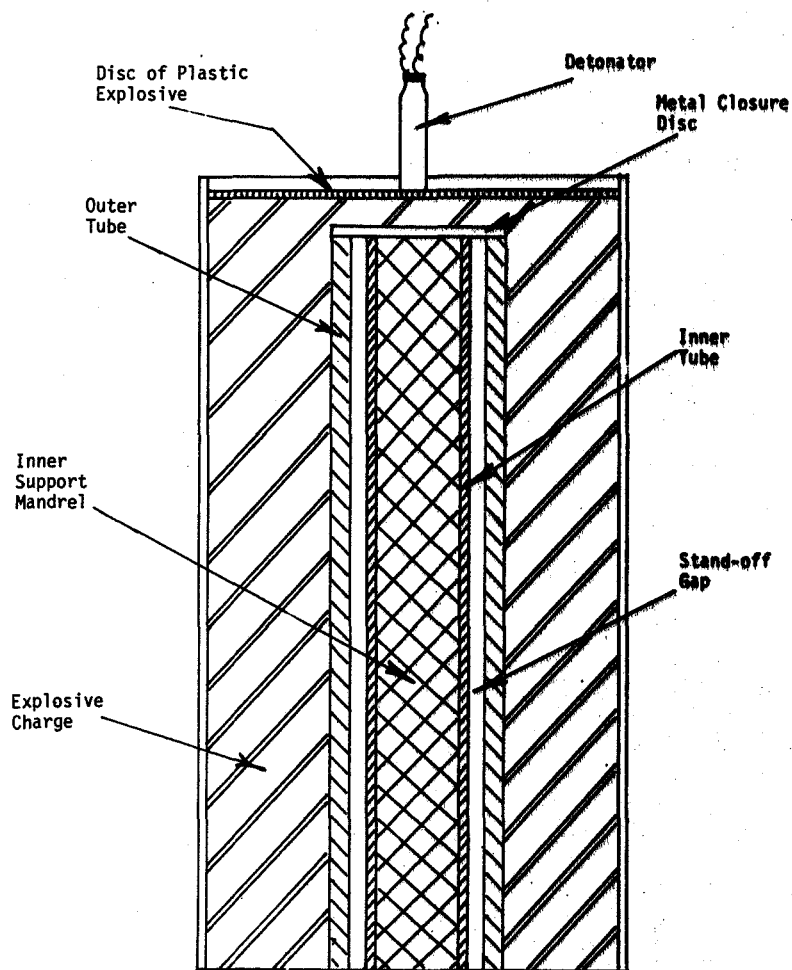

FIGURE 2

Parallel Geometry

This set-up is so called because the two surfaces to be welded are set a small distance apart and parallel to each other. The distance apart is called the stand-off gap. In a tubular configuration, the stand-off gap is annular in form. An explosive charge is used to propel the inner and outer tubular components together and this can be done in two ways:

a) Implosion Method

The basic set-up of this method is shown in Figure 2. A loose composite assembly of inner and outer tubes is set up with an annular stand-off gap between the components. Spacers are used at the tube extremities to achieve concentricity between the components and ensure uniformity of the annular gap. This loose composite is concentrically placed within a cardboard or plastic tube to form a second annular gap into which an explosive charge is poured. The dimension of this second annular gap is controlled to contain the requisite amount of explosive necessary to weld the tubes together.

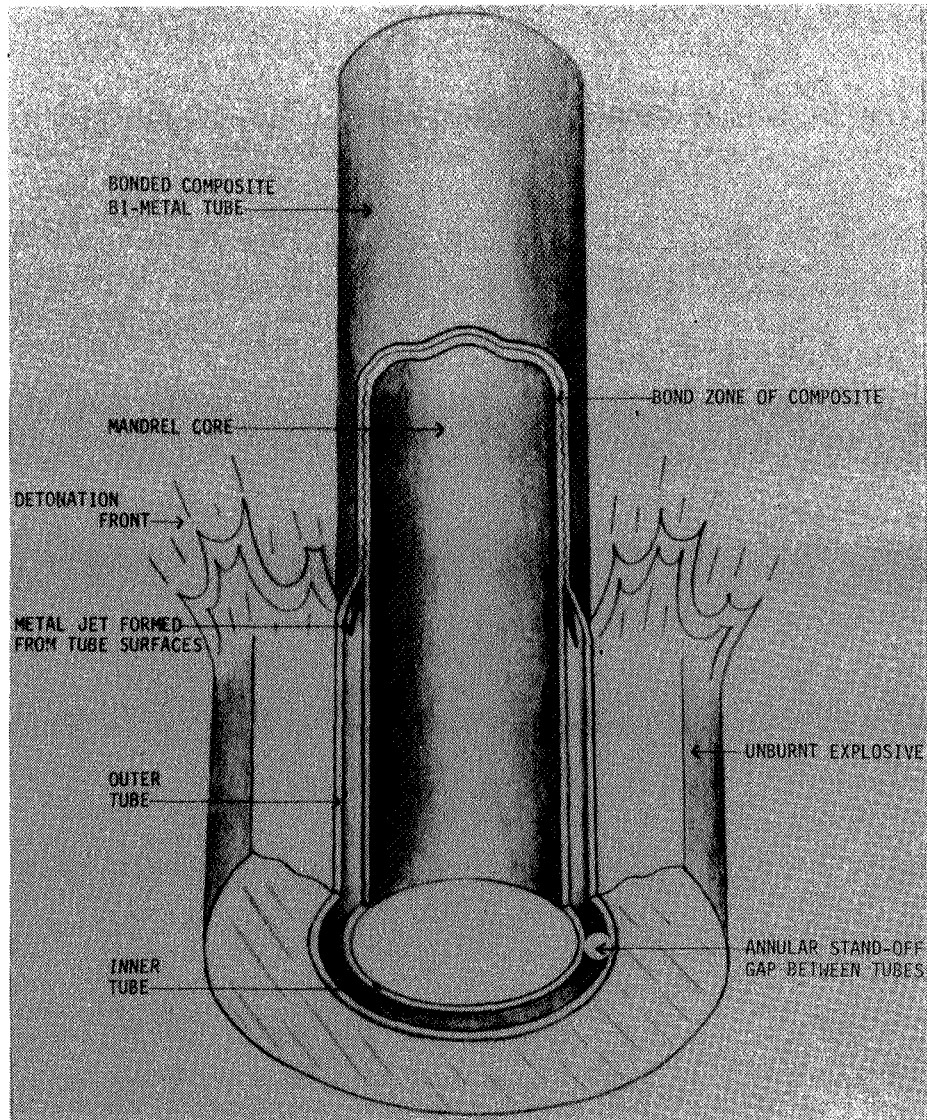

FIGURE 3

The explosive charge is initiated at one end by a disc of cap sensitive plastic explosive causing a detonation front to pass down the explosive charge. Immediately alongside the detonation front, the outer tube is propelled inwards over the stand-off gap to collide with the outer surface of the inner tube.

Because the outer surface of the inner tube and the inner surface of the outer tube are initially parallel to each other, the stand-off gap is uniform over its length. The distance that the collapsing tube must travel before colliding with the inner tube is, therefore, constant. Consequently, the collision front which has been generated will travel at a velocity identical to that of the explosive

detonation velocity. If the collision velocity is to travel at a velocity less than the material sonic velocity then so also must the detonation velocity be "subsonic".

Alternatively, the inner component may be a solid cylinder but if it is tubular in form, it may require internal support to prevent its collapse.

A schematic illustration of the implosion welding process in the dynamic situation is shown in Figure 3. The jet formed at the collision front can be seen and this jet, containing the surface contaminants originally present, is finally ejected from the interface.

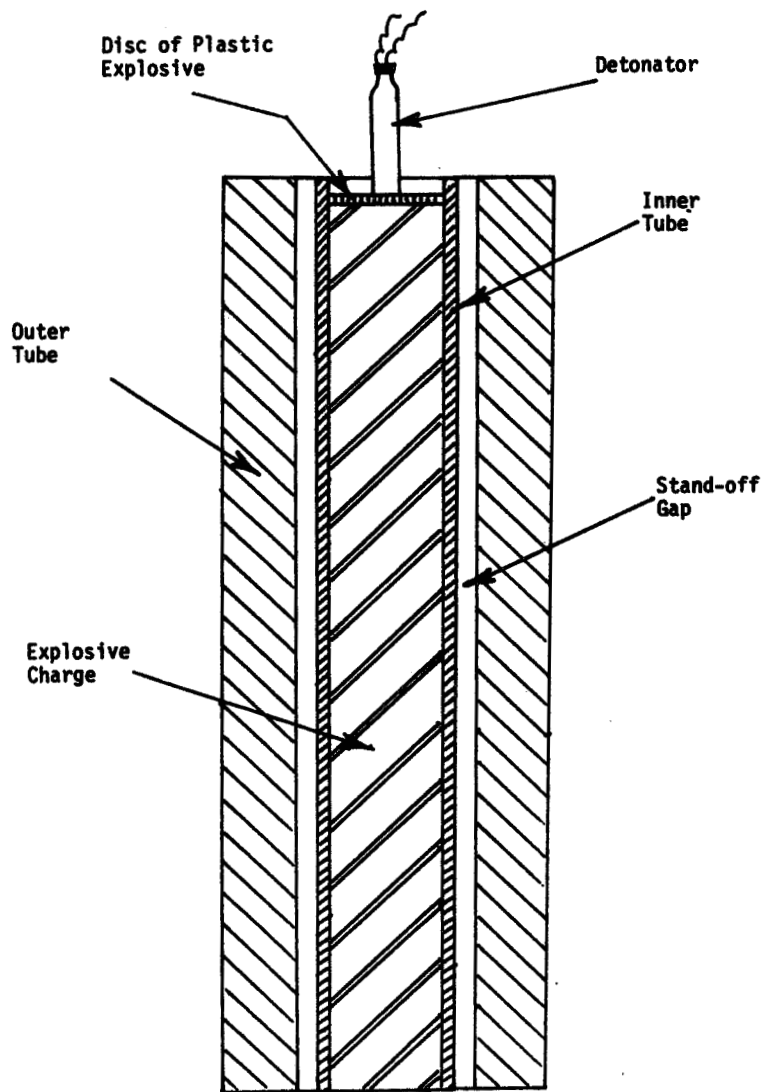

FIGURE 4

b) Expansion Method.

Figure 4 illustrates the set-up for welding by the expansion method. Once again a loose composite of the inner and outer tube components is set up with a concentric annular gap. The explosive charge usually fills up the bore of the inner tube and it is again initiated at one end by a disc of cap sensitive plastic explosive. The detonation front passes down the explosive and the inner tube is expanded radially at the detonation front to collide with the bore of the outer tube. A collision front is formed which travels down the annular stand-off gap. As the gap is again uniform over its length, the collision front and detonation velocities will be identical and a "subsonic" detonation velocity explosive must be used.

The outer tube component will ideally be of a substantial thickness which will withstand the impact of the expanding inner tube without distortion. If the thickness of the outer component is not adequate, an external die must be used.

Angular Geometry

As the name suggests, this set-up differs from the parallel geometry in that the two surfaces to be bonded lie initially at a pre-set angle to each other. In the case of tubular components, the stand-off gap is again annular in form but of a progressively increasing distance. Usually the inner tube is expanded outwards over the stand-off gap with the angular gap being contrived by either:

A divergent angle on the bore of the outer component or,

A convergent angle on the outer surface of the inner component.

a) Expansion Method

The most convenient method of expanding is shown schematically in Figure 5(a). An angular stand-off gap is achieved by countersinking the bore of the outer component which, in the illustration shown, is a tubular fitting.

The explosive charge is initiated at the innermost end coincident with the smallest stand-off gap and this produces a detonation front which travels outward toward the tube extremity. The inner tube is expanded radially at the detonation front to collide with the angular bore of the fitting. Because the distance that the tube must travel is progressively increasing, the collision front velocity is reduced substantially below that of the explosive detonation

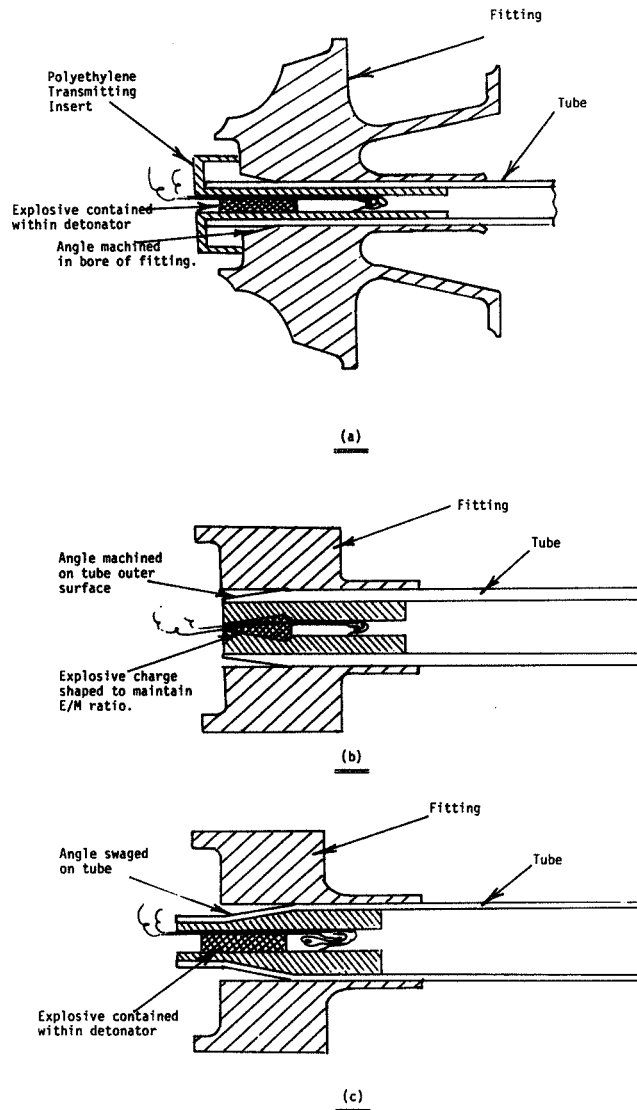

FIGURE 5

velocity. This feature creates the principal advantage of this geometry: A high "supersonic" detonation velocity explosive can be used while still maintaining a "subsonic" collision front velocity. Such explosives are of higher density and strength than "subsonic" explosives. As the tube bore size must ultimately determine the maximum volume of explosive that it will accommodate, the use of the more powerful "supersonic" explosive will allow smaller tubes to be welded.

The smallest tube welded to date by this method is a 0.260" O.D. x 0.204" I.D. 316L stainless steel tube which was welded into an Inconel 625 fitting similar that shown in Figure 5(a). The bond length achieved was one of 0.28" and a minimum length of 0.25" could not be separated by a chisel.

Figures 5(b) and 5(c) show alternative expansion methods in which the angular stand-off gap is achieved by either machining an angle on the tube 5(b) or swaging the tube 5(c).

Method 5(b) has the advantage of simplicity. Its disadvantage is a changing wall section which, if a constant explosive/metal mass ratio over the length is to be maintained, requires the use of a correspondingly shaped inwardly tapered charge. The positioning of this shaped charge is critical and must be accurately maintained. The wall thickness of the tube also limits the choice of angle in that, to achieve an adequate bond length, the angle must be shallow when the wall thickness is small.

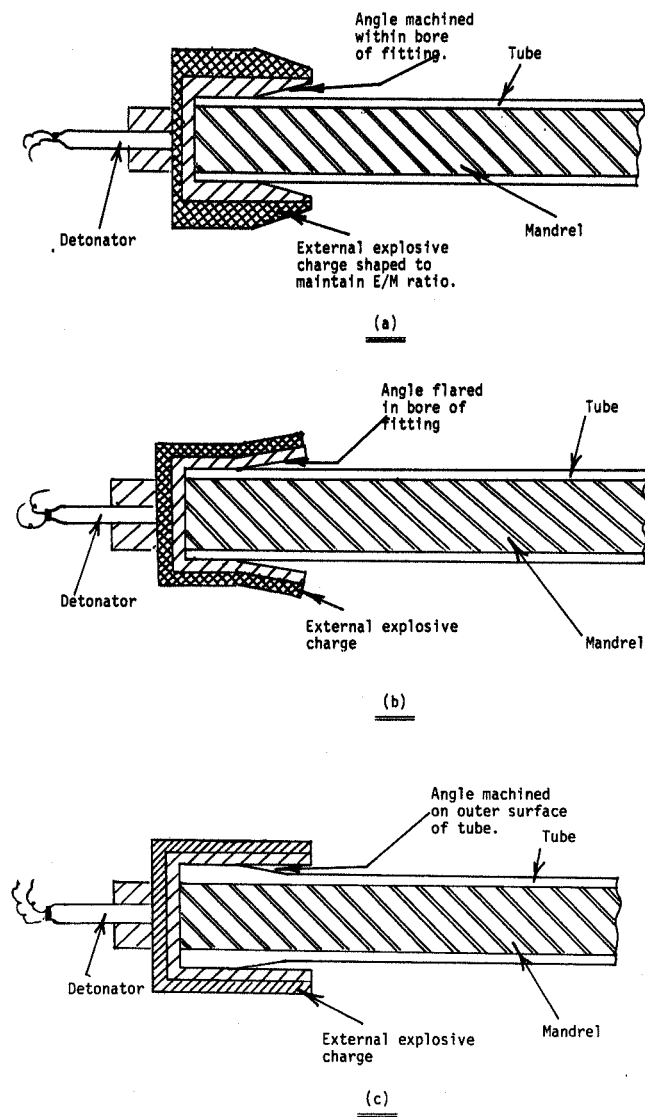

FIGURE 6

Method 5(c) requires the tube to be mechanically swaged but is otherwise less complex. The constant wall thickness gives much greater freedom in the choice of angle and does not require charge shaping.

Alternatively the outer tube can be imploded onto the inner component.

b) Implosion Method

A schematic representation of three alternative methods of imploding using angular geometries is shown in Figure 6. (a, b, and c).

Figure 6(a) shows an external fitting countersunk to create an angular stand-off gap. The high detonation velocity explosive surrounds the circumference of the fitting and it is initiated at the outer end to progressively collapse the fitting onto the inner tube or bar. Ideally the charge should be shaped to maintain the explosive/metal mass ratio over the bond length.

Figure 6(b) shows an alternative arrangement with the external fitting mechanically flared to create the angular gap. The constant wall thickness of the fitting avoids the necessity of shaping the charge.

Figure 6(c) illustrates a set up in which the angular gap is contrived by machining the angle on the outer surface of the inner component.

CHARACTERISTICS OF THE WELD

Metallographic examination of an explosive weld will usually show a characteristic wave form at the interface (Figure 7). A wave form is not necessary for bond strength, and flat interfaces are in some instances even desirable.

Associated with the peaks and troughs of the waves are discrete islands of "melt". This melt is material, originally molten, which has been rapidly chilled. If this material is an intermetallic formed from the component materials, it will be brittle. If bond strength is to be adequate, therefore, the collision parameters must be controlled to minimize the volume of these intermetallics. This can be achieved by avoiding excessive collision pressures and controlling the dynamic angle. If the collision parameters can be further controlled to form a straight interface, the intermetallics are entirely excluded. This degree of control is difficult to achieve in practice, however, and provided the "melt" is kept to acceptable proportions, the bond strength is very high and more than adequate.

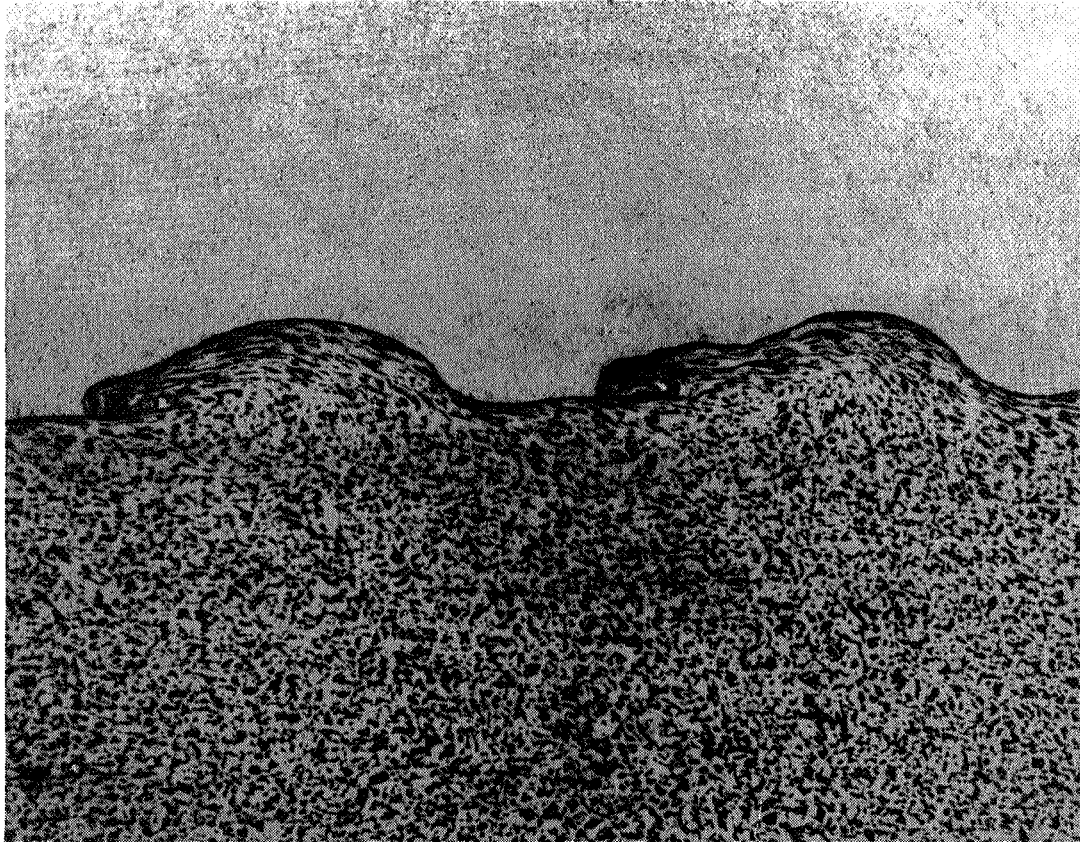

FIGURE 7

Destructive tests will usually result in failure of the weaker of the parent materials. Metal combinations which are a mix of hexagonal and cubic structured metals are more prone to fail at the bond. The strength of the bond may be more than adequate and the bond area can be increased to a point which will result in prior failure of the component parts.

Once the welding parameters are correctly established the welds are highly reproducible. An example of this reproducibility is demonstrated by the process of tube to tubesheet joining. In this instance, tube/tubesheet joints are fabricated by the angular technique with the tube being expanded into a countersunk tubeplate hole. Some 400,000 such joints have been made over a period of 15 years, and there is no recorded instance of joint failure.

Repairs of conventional tube/tubesheet joints have a similar unblemished record. In the repair situation a hollow plug is machined from solid bar and the open end is swaged in a similar manner to Figure 5(c).

TESTING OF JOINTS

Ultrasonic examination is the most commonly used non-destructive test method used for the inspection of explosively welded products. In the pulse-echo mode, the transducer is placed against the metal surface to transmit an ultrasonic pulse into the metal. If the metals are unbonded, the ultrasonic pulse is reflected by the interface. Alternatively, if the metals are bonded, the ultrasonic pulse passes through the interface and is reflected from the reverse side of the composite. In both cases, the reflected signal is received by the transducer and is displayed upon an oscilloscope screen as a deflection of the illuminated base line. The difference in pulse time travel between composites in the bonded and unbonded state is identified by the position of the deflection on the screen and is readily apparent.

The transducer used for the inspection of clad plates is usually about 1" in diameter. Small diameter transducers have been used to inspect many thousands of explosively welded tube to tube plate joints over a period of 20 years and the process has proved highly reliable. The same test apparatus and procedures can be used to inspect explosively welded tube to fitting joints. Ultrasonic testing, when combined with careful process controls and periodic destructive testing, can provide excellent assurance of product integrity.

Other forms of non-destructive tests which are commonly used are helium, hydraulic and pneumatic leak tests. All these tests provide additional assurance of bond quality.

Tensile, shear and compression tests are useful destructive tests which can be applied when determining bonding parameters. All give measures of the joint strength. Hydraulic testing to destruction gives a concomitant evaluation of joint strength and leak tightness should this be required. This is usually the case in tubular joint configurations.

SOME TYPICAL APPLICATIONS

Aluminum/Stainless steel is a metal combination often used in the aerospace industry. Obviously these two materials cannot be fusion welded together and transition joints are required if permanent connections are to be made. Figure 8 shows a typical transition joint in which a 1/8" O.D. x 1/16" bore, Type 321 stainless steel tube is bonded within a Type 6061-T6 aluminum boss. The 6061 aluminum has been bonded directly to the stainless steel and also with a type 1100 aluminum interlayer. In the particular joint configuration illustrated, the 6061 was imploded directly onto the stainless steel tube.

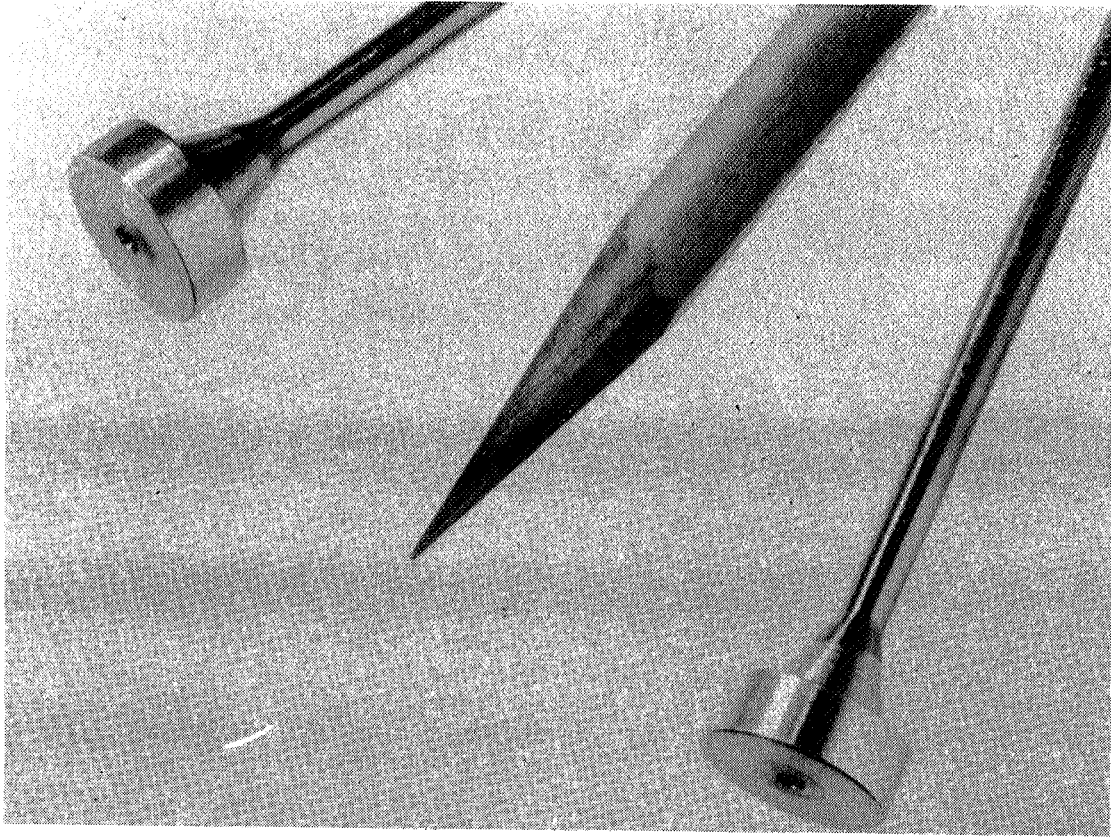

FIGURE 8

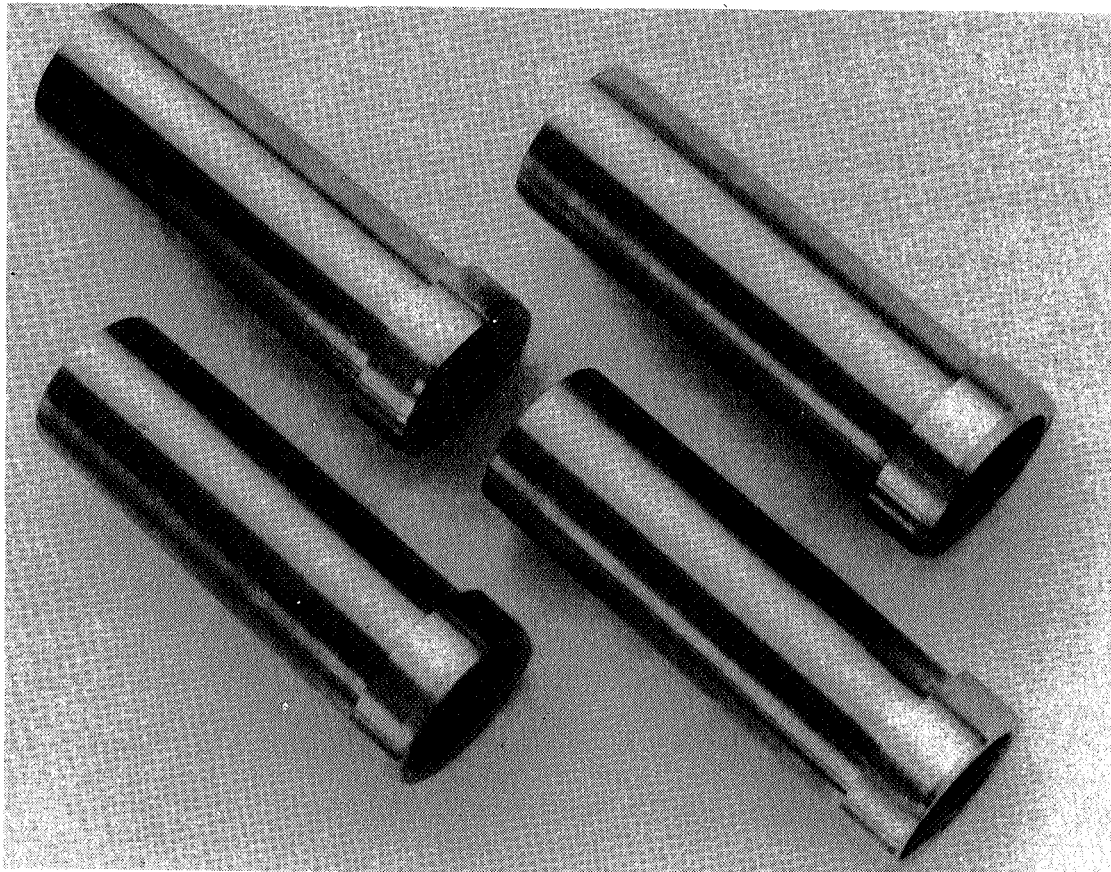

FIGURE 9

Figure 9 shows a second transition joint between a Type 304L stainless steel collar and a 3AL-2.5V titanium alloy tube. The very high yield strength of the titanium alloy tube has, in the past, made this particular metal combination impossible to explosively weld. The parameters for bonding are now established and welding can be just as readily and reproducibly achieved as with more familiar and frequently used metal combinations. The joint illustrated was again fabricated by implosion of the stainless steel collar onto the titanium alloy tube.

The particular shapes of transition joints are many and varied. It is necessary to approach each required configuration individually to decide the most appropriate geometry for its manufacture. The most appropriate method will be that which has the greatest commercial and technical viability.