

N85 - 33522

THE DESIGN AND DEVELOPMENT OF A SPACECRAFT APPENDAGE TIE DOWN MECHANISM

William D. Nygren and Raymond Head*

ABSTRACT

This paper describes the design and evolution of a spacecraft Appendage Tie Down Mechanism (ATDM), with particular emphasis on the mechanical aspects of using dry lubricants to increase the efficiency of acme threads and worm gearing.

ATDM - DESCRIPTION

The ATDM consists of five major components as shown in Figure 1 and in cross section (Fig. 2). These are (1) a DC torque motor, (2) a worm gear speed reducer, (3) the tension bolt (or T-bolt), (4) nut capture and centering jaws and (5) the capture nut. In addition, there are several minor components such as limit switch assemblies and an anti-backdrive mechanism which couples the drive motor to the worm shaft.

ATDM - OPERATION

The operational sequence is as follows: First the DC torque motor drives the T-bolt through the worm gear speed reducer with a ratio of 58 to 1. The worm gear hub is splined, allowing T-bolt axial advancement while the worm gear rotates. The center section of the T-bolt is a ball screw which advances the T-bolt through its fixed ball nut at a rate of 0.508 cm (0.200 in.) per revolution. The next step is the capture and centering of the nut assembly (see Fig. 4). As the T-bolt advances, it drives the two capture jaws to swing closed. This forces the nut to the proper position to allow the acme threads on the tip of the T-bolt to engage the nut threads.

The capture nut is free to move axially in its housing against two sets of springs. The first is a "soft" stack of wave washers which allows the T-bolt to fully engage the nut under low thread loading. The second stack is made up of Belleville washers which start compressing only after the soft stack spring has completed its stroke. The Belleville springs reach an axial force of 22 678 N (5100 lb) during one revolution of the T-bolt. The mechanism is then shut off by limit switches on the nut housing, which monitor nut spring travel. Figure 3 shows the limit-switch mounting on the nut assembly.

The actual loading or tensioning of the T-bolt by the nut is accomplished by the difference in the leads of the ball screw thread and the acme capture thread on the forward end of the T-bolt. The lead of the ball screw is

*Martin Marietta Aerospace, Denver, Colorado

0.508 cm/rev (0.200 in./rev) while that of the 1.905 cm (0.750 in.) double-lead acme screw is 0.846 cm/rev (0.333 in./rev). The T-bolt always advances out of the mechanism at a rate of 0.508 cm/rev (0.200 in./rev); however, after the acme thread engages the capture nut, the nut advances relative to the bolt at a rate of 0.846 cm/rev (0.333 in./rev). Thus the net compression of the nut springs is 0.338 cm (0.133 in.) per revolution of the T-bolt.

DESIGN EVOLUTION

As system requirements were refined, the preload that the ATDM was supposed to develop was substantially increased. The original preload was defined to be 7115 N (1500 lb) maximum. After the first development unit was built, this figure was increased to approximately 13 344 N (3000 lb), and finally to 22 678 N (5100 lb). This tripling of output force required that most attention be focused on mechanical efficiency as the electrical power to drive the mechanism was "fixed" as was the time available for the entire operation to take place. The increased capability of the mechanism was required to take place within the original physical envelope.

To provide this increased capability, the following improvements were made. First, the gear ratio was changed from 50-1 to its present value of 58-1. No further increase was allowable because of gear tooth strength considerations and size and time limitations. The next step was to change from a V-thread to the present ball screw for the driver thread. This was a major improvement; the apparent coefficient of friction dropped from 0.18 to 0.007.

Although this was a major improvement, a 100% torque margin under worst-case conditions of voltage, temperature, and motor K_t torque constant had yet to be demonstrated.

The original development unit had used wet lubricant (Braycote 3L-38RP) for surfaces, and it was calculated during testing that the efficiencies of these two components were around the 30% range because of a coefficient of friction of approximately 0.2 at the mating surfaces. Since the mechanism efficiency was basically the product of the gear box and acme screw efficiencies, the overall mechanism efficiency was only about 10%. A decision was therefore made to switch to a dry lubricant such as molydisulfide for these sliding surfaces of the ATDM the worm/worm gear and the acme capture threads.

The dry lubricant recommended by Materials Engineering was LUBECO 905 as Martin Maretta Co. (MMC) has previously obtained good results with it. After successful application of LUBECO 905, the observed coefficient of friction was .1 or lower at both worm/worm gear interface and at the acme bolt/nut interface in a vacuum environment, this value was seen to further decrease to the point where efficiencies above 60% were obtained for the individual components, approximately a four-fold increase for the overall mechanism.

DRY-LUBRICANT DIFFICULTIES

When the mechanism was first lubricated with LUBECO 905 and reassembled, it failed almost immediately during testing. This caused careful reanalysis of the use of dry-film lubricants. Based on the calculated contact stress and wear life required to survive testing, the lubricant should have been successful. However, upon further investigation, the following important facts were learned.

- o No matter how well made and aligned they are, a worm and worm gear must go through a wear-in period before a true line contact area is established across the face of each gear tooth.
- o In a similar fashion, male and female screw threads must also be mated together by a wear-in period before true area contact is established to support the load.
- o All sharp corners must be removed around each worm and gear tooth, and on all corners of both the male and female acme thread. In particular this must be done at any partial threads which spiral from minor to major diameters (or vice-versa) such as occurs at the beginning and ending of both the male and the female threads.
- o After the proper contact areas are established, the mating parts should be burnished together, starting with low loads and working up to the full flight loads in gradual steps.

LAPPING

To facilitate a rapid wear-in of the worm/worm gear and T-bolt/nut of the ATDM, the decision was made to lap the mating surfaces together with a grinding compound. Since it is desired to force one surface to conform to the other, both the worm and the T-bolt acme thread were hardened by nitriding prior to starting the lapping process. These surfaces were chosen for the following reasons. It was felt that the T-bolts contour could be more accurately manufactured and dimensionally verified than could its mating nut. The worm was chosen for hardening because it has basically one tooth, which must wear in each tooth of the worm gear to match it exactly. (Thus the worm gets 58 times the wear that any particular worm gear tooth gets during lapping).

After nitriding was completed, the worm/worm gears were serialized along with their housing to be maintained as a matched set. The gear box was then reassembled. The output shaft was attached to a brake which could apply 1.13 N-m (10 in.-lb) of drag. The worm and worm gear were then coated with a 320-grit Clover grinding compound, and the worm was driven at 200 rpm until the desired wear pattern was established across the face of each tooth. Finally, the 320-grit compound was replaced with a 600-grit compound to leave a 16-# to 32-rms surface finish for the application of the LUBECO 905.

In a similar manner, the T-bolt and caging nut were lapped together with the same compounds under a constant axial load of 22-44 N (5-10 lb), with the nut fully engaged with the bolt. A special fixture was designed for this purpose (Fig. 5).

BURNISHING

After lapping, the critical parts were relubricated with LUBECO 905. The gear box was then reassembled and reattached to the brake. This time, however, the load was gradually increased in approximately 14 steps to an output torque of 40 N-m (360 in-lb). At this point the input torque was measured to be 0.15 N-m (1.3 in-lb), giving an efficiency of 49.7% under stall conditions. (This would further improve in vacuum conditions.) Likewise, the T-bolt and nut were burnished together at gradually increasing axial load levels to a final load of 17 787 N (4000 lb). Here the torque required to rotate the bolt was measured as 33 N-m (291 in-lb), giving an efficiency of 73%. (The bolt required a torque of 12 N-m (105 in-lb) to keep it from overhauling). A coefficient of friction of 0.06 in air can be deduced from these values and the thread geometry.

ANTI-BACK-DRIVE MECHANISM

The success of the dry film lubricant was not completely without a drawback because it led to a further complication.

At the 22678 N (5100-lb) preload level, it was found that the acme thread would back-drive its low coefficient of friction and large helix angle. This torque was about 17 N-m (150 in-lb) in air and would possibly double under vacuum conditions. The conclusion was that the acme thread could overcome the holding torque produced by the ball nut and so deliver a back-driving torque to the worm gear. Here the low friction coefficient is again harmful as it allows a normally locking gear ratio to back-drive. This potential for back-driving is particularly hazardous during the launch and boost phases of a flight, because the harsh vibration environment increases the likelihood for back-driving, at a time when a loss of ATDM preload would be most dangerous.

Of the many possible solutions to this problem, most either caused an unacceptable constant loss of motor torque or required electrical power and control lines which were not available. The solution was to make the coupling between the drive motor and the worm serve as a ratchet which would allow the motor drive the worm in either direction, but not allow the worm to back-drive the motor. The operation of this device is shown in Fig. 6.

The mechanism consists of a detent disk attached to the worm shaft, and a cam disk attached to the motor shaft. These two disks are coupled together by a pin attached to the detent disk, which rides in a slot in the cam disk. This arrangement allows approximately 60° of relative motion between disks. There is also a Vlier-type plunger between the disks (not shown), which locks the disks into the configuration shown in Fig. 6a prior to the start of operations. The final component is the ratchet dog, which in this case has a roller to minimize friction.

The operation is as follows: First, as the motor starts running (see Fig. 6a), the roller rides on the combined outside diameter of the two disks and is held in this configuration by the Vlier pin between them. When the mechanism approaches its desired preload, the transmitted torque becomes large enough to overcome the Vlier pin, the disks shift to the configuration shown in Fig. 6b, and the dog starts ratcheting. Next, if the worm attempts to back off, it can rotate back only until the roller comes against the now "uncovered" detent (Fig. 6c). Finally, when the mechanism, is desired to be uncaged the reversal of the drive motor causes the cam disk to cam the roller out of the detent, and the back-out can commence as shown in Fig. 6d.

PRESENT STATUS

A development model of the ATDM in various configurations has been under test for some time. In its latest version, it has successfully completed thermal vacuum testing, vibration testing, and extended-life testing. Qualification and flight units are scheduled for testing.

ORIGINAL PAGE IS
OF POOR QUALITY



FIGURE 1. ATDM

ORIGINAL PAGE IS
OF POOR QUALITY

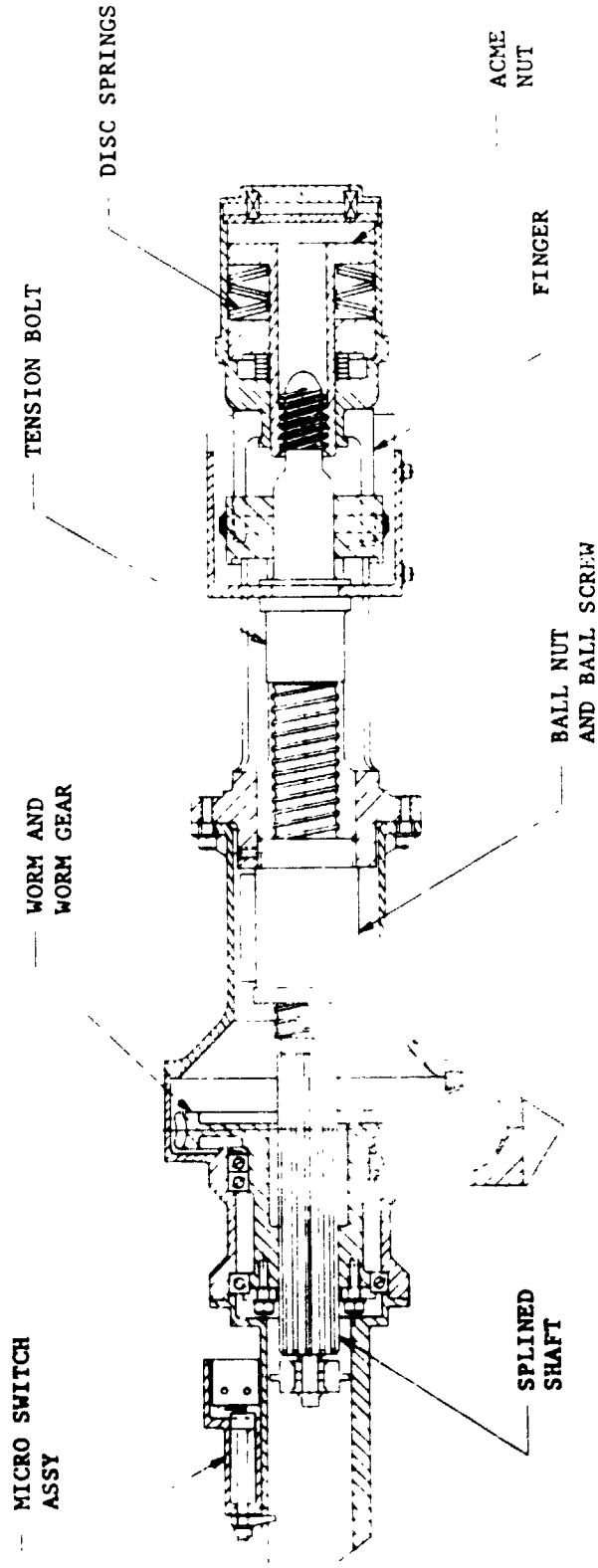

FIGURE 2. MECHANISM CROSS SECTIC.

ORIGINAL PAGE IS
OF POOR QUALITY



FIGURE 3. NIPY AND FINGER CONFIGURATION

ORIGINAL PAGE IS
OF POOR QUALITY



FIGURE 4. CAGING SEQUENCE

ORIGINAL PAGE IS
OF POOR QUALITY

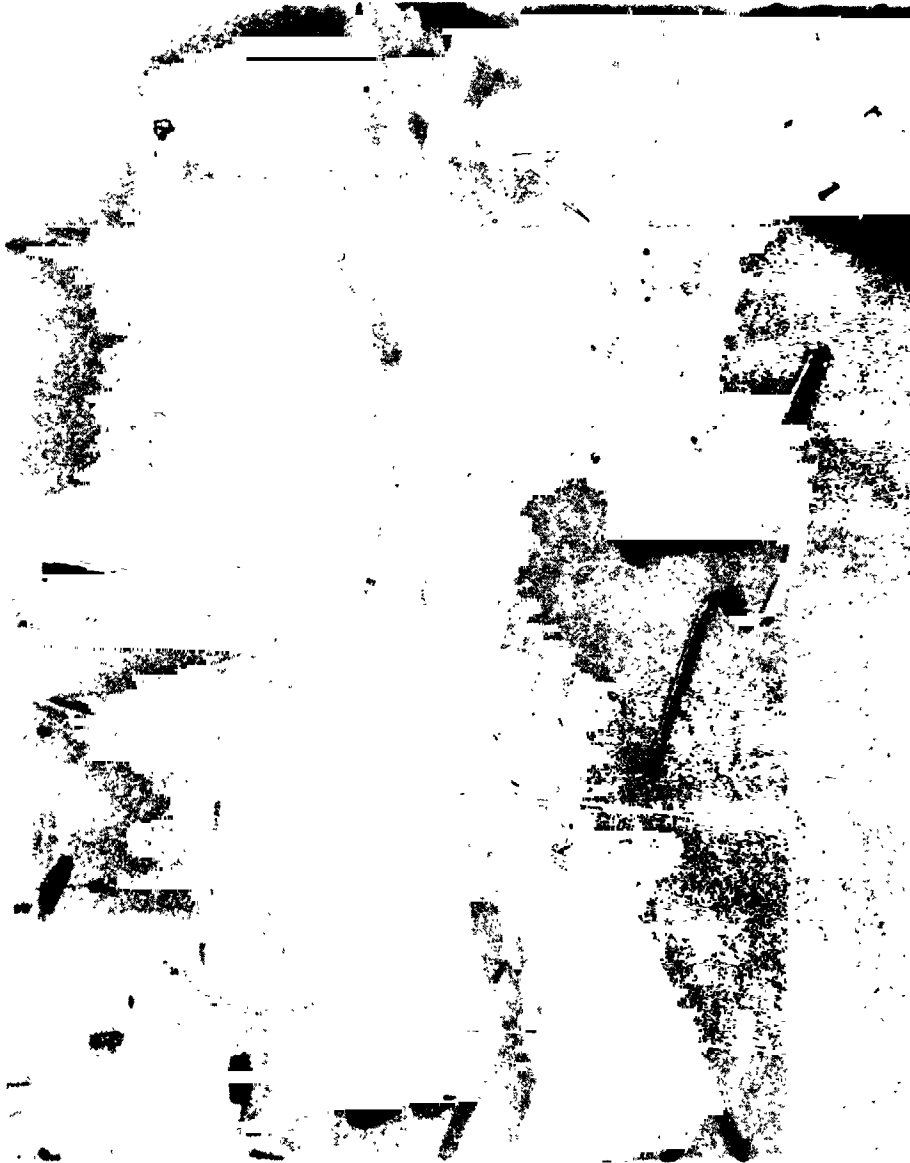

FIGURE 5. BOLT AND NUT LAPPING FIXTURE

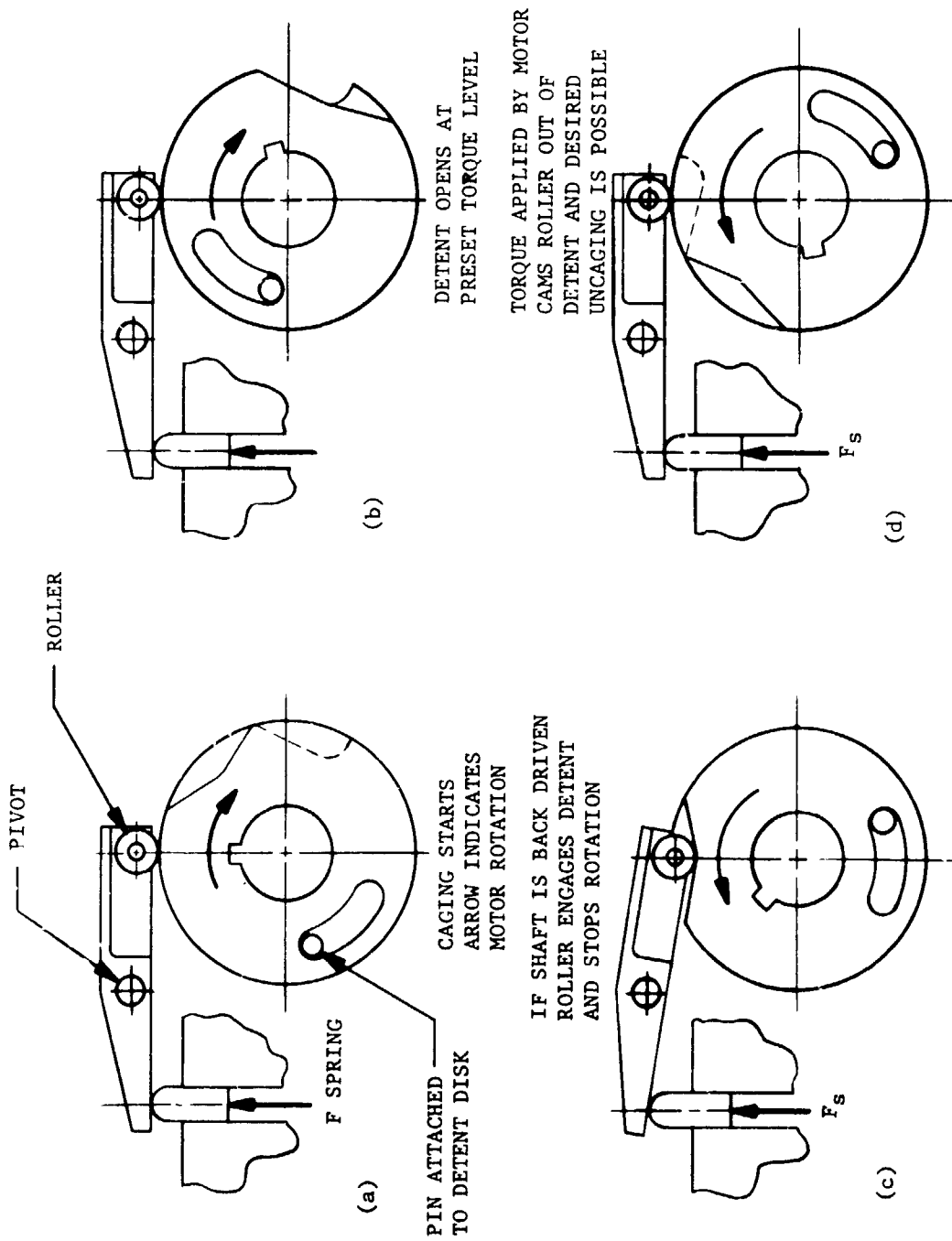

FIGURE 6. ANTI-BACK-DRIVE MECHANISM