

N85-25875

AUTOMATIC DYNAMIC AIRCRAFT MODELER (ADAM) FOR THE COMPUTER PROGRAM NASTRAN

Hugh Griffis
Nuclear Survivability Group
System Survivability Branch
ASD/ENSSS
Wright-Patterson AFB OH 45433-6503

SUMMARY

Large general purpose finite element programs require users to develop large quantities of input data. General purpose pre-processors are used to decrease the effort required to develop structural models. Further reduction of effort can be achieved by specific application pre-processors. Automatic Dynamic Aircraft Modeler (ADAM) is one such application specific pre-processor.

INTRODUCTION

General purpose pre-processors use points, lines and surfaces to describe geometric shapes. Specifying that ADAM is used only for aircraft structures allows generic structural sections, wing boxes and bodies, to be pre-defined. Hence with only gross dimensions, thicknesses, material properties and pre-defined boundary conditions a complete model of an aircraft can be created.

NASTRAN models generated by ADAM include the executive, case control and the bulk data sets for normal modes analysis. The bulk data cards generated by ADAM are: GRID, CQDMEM2, CSHEAR, CROD, PQDMEM2, PSHEAR, PROD, MAT1, MAT2, CONM2, SPC1, ASET1, EIGR and PARAM (REF1). Additionally, the case control deck is setup to plot the first ten eigenvectors.

WING BOXES

Geometric Modeling

Geometric modeling is completed by using simple quadrilateral surfaces. Surfaces are easily defined, meshed and connected to other surfaces. The upper wing surface coordinates must be defined, then the lower surface coordinates may be defined or automatically generated. The surfaces use CQDMEM2 elements to represent the aircraft skin. Once the upper and lower surfaces are defined, they are automatically connected by CSHEAR and CROD elements. CSHEAR elements represent spars and ribs, while CROD elements represent spar and rib caps. Figure 1 shows the type of data required for each quadrilateral surface.

The software's logic allows multiple quadrilateral wing sections to be created separately and then later connected to generate a complete wing. When multiple wing sections are connected, the duplicate grid points are deleted and the element connectivity list along with the grid identification (GID) for constraints and active degrees of freedom (DOF) are altered accordingly. Grid points which are

within ERROR distance apart are treated as duplicate grid points. The ERROR distance is a user input value.

Surface element thickness is automatically tapered inboard (maximum thickness) to outboard (minimum thickness), while element thickness from the leading edge to the trailing edge remains constant. Figure 2 shows how the actual structure varies from the finite element model. The skin tapering routine is available for homogenous and composite materials. In-plane composite materials are simulated by stacking elements. Each layer has its own fiber orientation description which is defined from a reference orientation.

Mass Modeling

Structural and nonstructural mass (NSM) modeling is available in ADAM. Structural mass includes skin, spars, ribs, spar and rib caps. Nonstructural mass includes fuel, avionics, crew and all other nonstructural materials. ADAM's structural mass modeling only requires the material density, then NASTRAN distributes the mass to grid points by using the element thickness and area

$$\text{Mass} = \text{Thickness} \times \text{Area} \times \text{Density.}$$

Nonstructural mass is applied to the element area. NASTRAN requires the user to input the NSM as

$$\text{NSM} = \text{NSM Thickness} \times \text{Density.}$$

NASTRAN distributes the mass to grid points by using the element area

$$\text{Mass} = \text{NSM} \times \text{Area.}$$

Calculation of NSM thickness for each element in the wing box is a tedious job. Hence ADAM calculates the NSM thickness of the wing by using the corner points of each element

$$Z \text{ thick} = \frac{\sum(Z \text{ upper} - Z \text{ lower})}{3}$$

$$Y \text{ thick} = \frac{\sum(Y \text{ upper} - Y \text{ lower})}{8}$$

$$\text{Thickness} = \sin(\text{wing dihedral}) \times Y \text{ thick} + \cos(\text{wing dihedral}) \times Z \text{ thick.}$$

Half of the thickness, hence the NSM is applied to the upper element and the other half of the NSM is applied to the lower element. Since ADAM calculates the thickness, the user is only required to input nonstructural mass density. Typically, nonstructural mass density for a wing section is not known, thus this value is changed until the gross weight is correct.

Boundary Conditions

ADAM has six wing sections with default boundary conditions: vertical wing with free boundary conditions, horizontal wing with free boundary conditions, horizontal wing carry through, vertical centerline wing carry through, vertical centerline wing with symmetric boundary conditions and vertical centerline wing with anti-symmetric boundary conditions. Figure 3 shows the cross sectional view of the above wing sections.

Horizontal and vertical wing carry through sections are designed for uncoupled wing-body motion, with the inboard part of the wing fixed. However, coupled wing-body motion can be correctly modeled by manually changing the inboard constraints. Geometric modeling for wing-body coupling is more difficult, hence is not used unless strong coupling is expected.

Centerline wing sections only model half of the structure and the skin on the centerline is not generated. Grid points on the centerline are constrained for symmetric or anti-symmetric analysis. Symmetric boundary conditions allow motion in the Z direction along the centerline

SPC1 GID 12456,

while anti-symmetric boundary conditions allow motion in the Y direction along the centerline

SPC1 GID 13456.

Active Degrees of Freedom

ASET1 cards are automatically generated for each wing surface. An optional switch generates ASET1 cards for upper and lower surfaces or for the upper surface only. Little error is introduced by using ASET1 cards on the upper surface only and the active degrees of freedom are cut in half. Another option allows the user to spatially distribute the ASET1 cards in the chord and span directions. This option gives the user an automatic method of assigning ASET1 cards to selected grid points for each wing surface.

Reducing six degrees of freedom to one for each grid point can introduce large error. However, by assigning the active degree of freedom in the dominant direction of motion the error can be reduced to the engineering accuracy of the original model. Once the desired accuracy has been reached, further reduction of the analysis set can be achieved by selecting a smaller set of grid points with the same active degrees of freedom. Since each wing section is uniform in terms of mass and stiffness, spatical distribution of ASET1 card causes no loss of accuracy. However, high frequency modes may be lost if too many grid points are skipped. A convenient rule of thumb to determine the maximum number of modes that are calculated for a given direction is

$$\text{number of modes} = \text{number ASET1 cards} - 1$$

Additional care must be used when large concentrated masses are used. The user must ensure that each grid point with large mass has the appropriate active degree of freedom since ADAM only distributes ASET1 cards spatially.

BODIES

Geometric Modeling

Geometric modeling is completed by defining an X station with several radial vectors, angles and magnitudes. The outer radius defines the skin location. CQDMEM2 elements represent the skin. The inner and outer radii define the height of the

frames and longerons. CSHEAR elements represents frames and longerons, while CROD elements represent frame and longeron caps. Figure 4 shows the type of data required for each body.

Complex body shapes can easily be created, hence the volume of input data is large when compared to the wing input data. Geometric modeling of bodies does not support skin tapering and composite materials, however automatic renumbering for duplicate grid points is available.

Mass Modeling

Structural and nonstructural mass modeling is available for bodies. This section is identical to the wing mass modeling except for the thickness calculation. ADAM calculates the cross sectional thickness of the body for each element

$$\text{Thickness} = \left[\left(\frac{\sum(Z - \text{camber})}{4} \right)^2 + \left(\frac{\sum(Y \text{ inner} - Y \text{ outer})}{2} \right)^2 \right]^{1/2}$$

The mass is only applied to the grid points defined by the outer radius.

Boundary Conditions

ADAM has four body sections with default boundary conditions: user defined active degree of freedom, all points fixed, centerline body with symmetric boundary conditions and centerline body with anti-symmetric boundary conditions. Figure 5 shows the above body sections.

Only half of the structure is modeled if the centerline body option is chosen. Grid points on the centerline are constrained for symmetric or anti-symmetric analysis. Symmetric boundary conditions allow motion in the Z direction along the centerline

SPC1 GID 12456,

while anti-symmetric boundary conditions allow motion in the Y direction along the centerline

SPC1 GID 13456.

Active Degree of Freedom

ASET1 cards are automatically generated for each body section. This section is identical to wing modeling except that ASET1 cards are only assigned to grid points defined by the outer radius.

MASS

Structural and nonstructural mass can automatically be distributed for wings

and bodies. Additionally, concentrated masses can automatically be assigned to the nearest grid point. ADAM determines the nearest grid point then calculates the offset distance. This routine requires relatively large amount of computer time, hence is turned off until the final structural model is completed.

SUMMARY TABLE

In addition to the NASTRAN model, ADAM also generates a summary table. The summary table is mainly the input data with appropriate labels. Other labels denote which input values are used for geometric, constraint, material and mass modeling. These labels provide convenient guidelines when debugging ADAM's input data. The summary table is written immediately after the input data is read, hence the data on the summary table is conveniently in the same order.

Coordinates of the corner grid points of each wing section are calculated from the input angle data. The coordinates and the GID's for the corner points of each wing section are written on the summary table after all duplicate grid points have been deleted. This data aids the user when multiple wing sections are being connected.

Warning messages are written on the summary table when CQDNEM2 and CSHEAR elements have three or less unique grid points. Typically, the routine which deletes duplicate grid points triggers this warning message and can be corrected by decreasing the ERNOR distance.

CONCLUSION

The logic built into ADAM reduces the effort and knowledge required to build complex aircraft structural models. ADAM's pre-defined wing boxes and bodies gives even novice NASTRAN users advanced modeling skills. Advanced NASTRAN users will find that the tedium of data generation for parametric and design studies is greatly reduced. In general, anyone who builds structural models with ADAM will be more productive and adaptable to design changes.

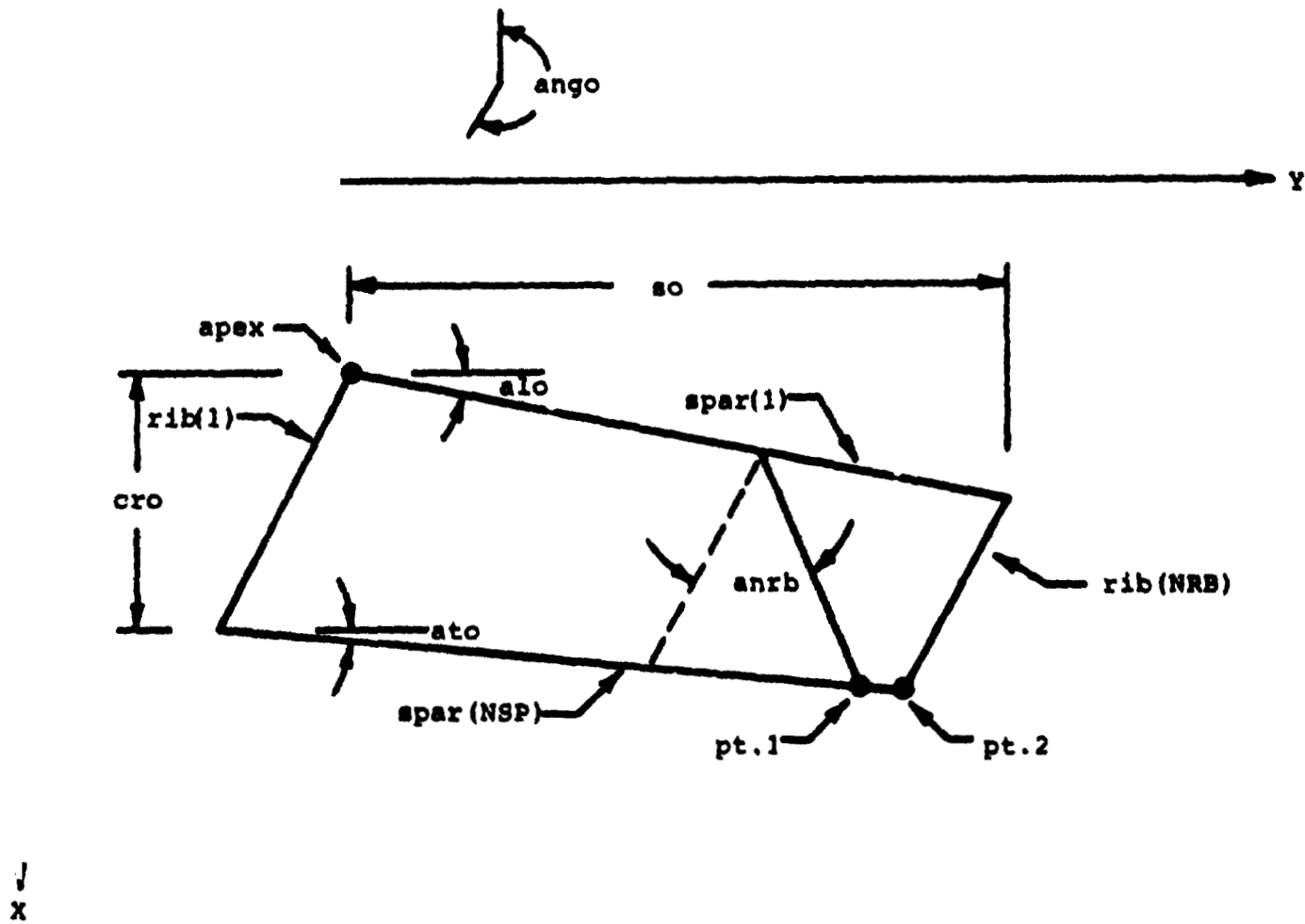

↓
x

Top view of wing planform. If pt.1 is rotated such that pt.1 equals pt.2, the quadrilaterals degenerate into triangles.

FIGURE 1 WING GEOMETRIC DEFINITIONS

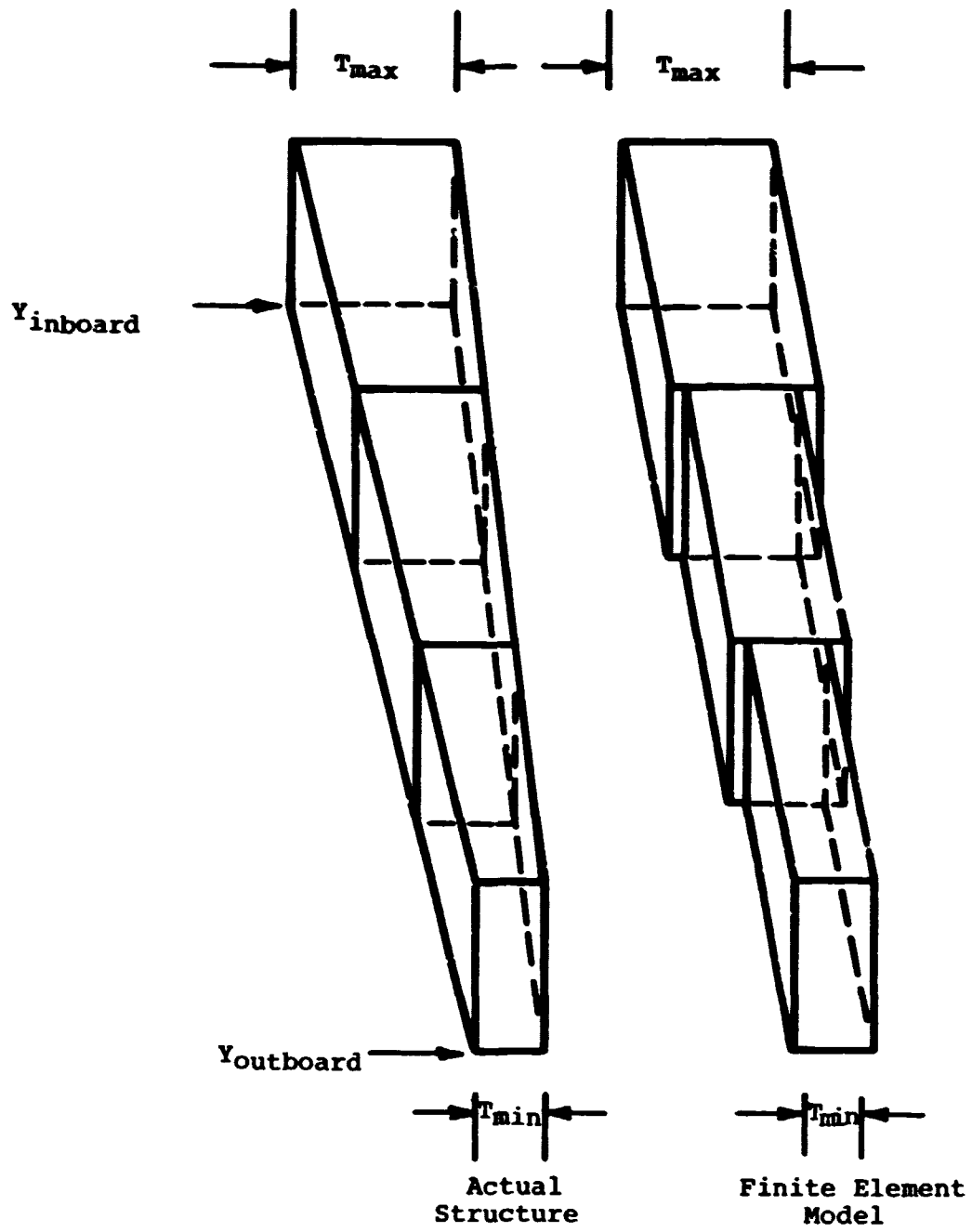
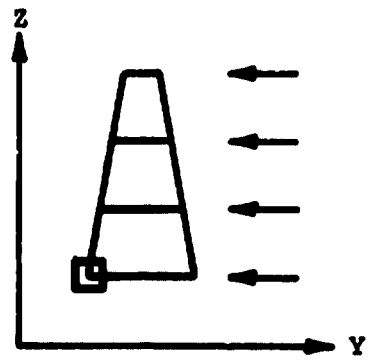
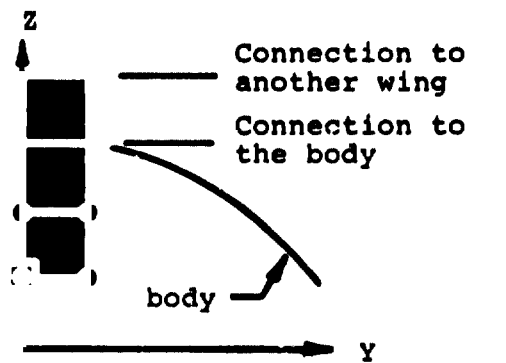

FIGURE 2 SKIN TAPERING



Vertical wing with free boundary conditions



Vertical wing carry through

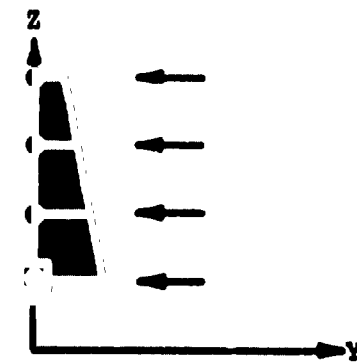

Wing with anti-symmetric boundary conditions

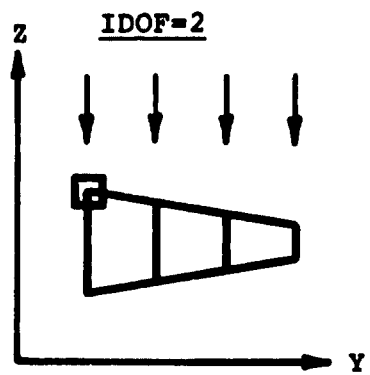

Horizontal wing with free boundary conditions

IDOF=3

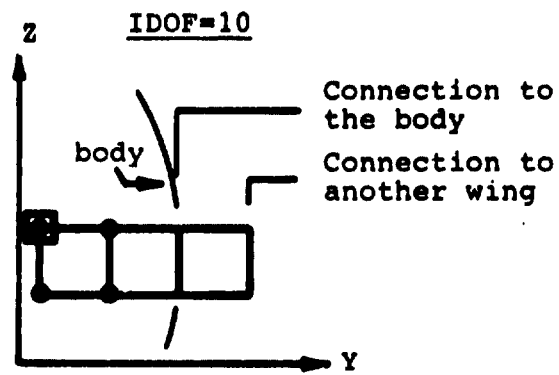

Horizontal wing carry through

IDOF=7

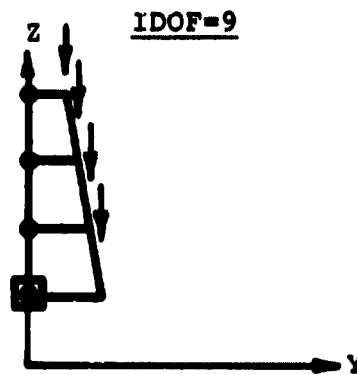

Wing with symmetric boundary conditions

IDOF=8

Cross section view looking from leading to trailing edge of wing section. The arrows, \downarrow , denote the direction of the active degree of freedom. The squares, \square , denote the apex. The dots, \bullet , denote the point is fixed. If IDOF is equal to 8, 9 or 10, the apex must be on the centerline.

FIGURE 3 WING BOUNDARY CONDITIONS

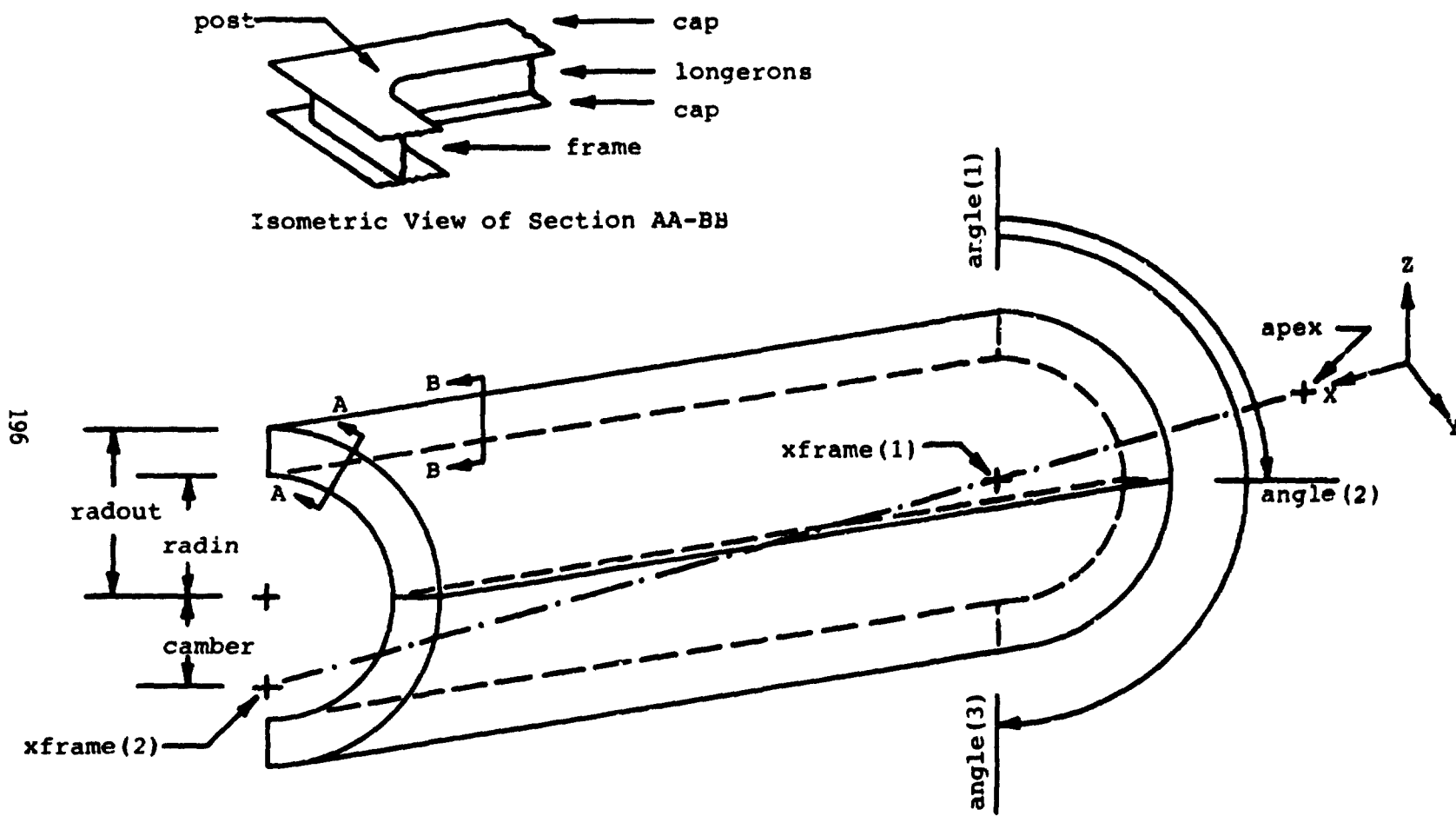
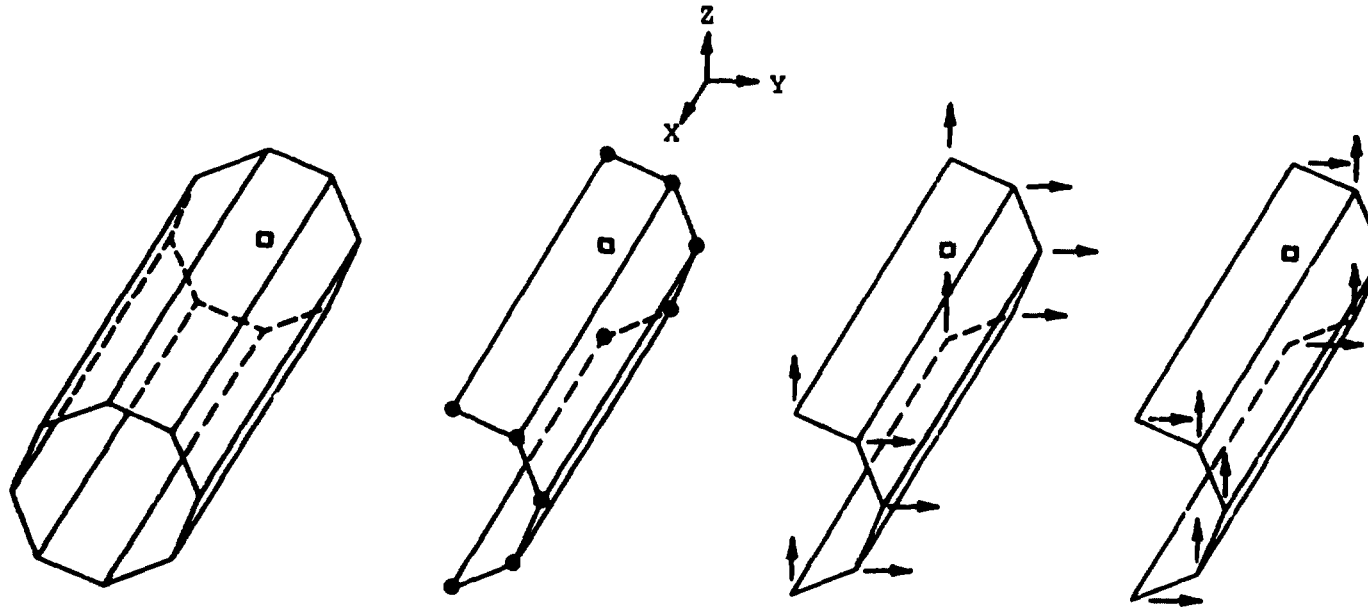

FIGURE 4 BODY GEOMETRIC DEFINITIONS



User defined active
degree of freedom:

- 1 for X direction
- 2 for Y direction
- 3 for Z direction

All points are fixed

The centerline is
fixed in the X
and Y direction.
Centerline has
active degree of
freedom in Z
direction. All
other points have
an active degree
of freedom in the
Y direction.

The centerline is
fixed in the X
and Z direction.
Centerline has
active degree of
freedom in Y
direction. All
other points have
an active degree
of freedom in the
Z direction.

IDOF = 1, 2, 3

IDOF = 7

IDOF = 8

IDOF = 9

The arrows, \downarrow , denote the direction of the active degree of freedom. The squares, \square , denote APEX. The dots, \bullet , denote the point is fixed.

FIGURE 5 BODY BOUNDARY CONDITIONS

REFERENCES

1. NASTRAN Users Manual
2. Automatic Dynamic Aircraft Modeler (ADAM) Volume I. January 1985, ASD/TR
3. Flexible Airframe Design Loads (FLEXLOADS) Volume II. March 1984,
AFWAL-TR-80-3036
4. MSC/NASTRAN Primer, Static and Normal Modes Analysis. January 1982.