

N85-22472

SUPRATHERMAL PLASMA OBSERVED ON STS-3 MISSION BY PLASMA DIAGNOSTICS PACKAGE*

W. Paterson, L. A. Frank, H. Owens,
J. S. Pickett, and G. B. Murphy
University of Iowa
Iowa City, Iowa 52242

S. D. Shawhan
NASA Headquarters
Washington, D.C. 20546

Artificially produced electron beams have been used extensively during the past decade as a means of probing the magnetosphere (ref. 1), and more recently as a means of actively controlling spacecraft potential (ref. 2). Experimentation in these areas has proven valuable, yet at times confusing, due to the interaction of the electron beam with the ambient plasma. The OSS-1/STS-3 Mission in March 1982 provided a unique opportunity to study beam-plasma interactions at an altitude of 240 km. On board for this mission was a Fast Pulse Electron Generator (FPEG), which served as part of Utah State University's Vehicle Charging and Potential experiment. Measurements made by the Plasma Diagnostics Package (PDP) while extended on the Orbiter RMS show modifications of the ion and electron energy distributions during electron beam injection.

In this paper, some of the observations made by charged particle detectors are discussed and related to measurements of Orbiter potential. The paper is divided into three sections. A brief description of several of the PDP instruments appears first, followed by a section describing the joint PDP/FPEG experiment. The third section consists of observations made during electron beam injection.

INSTRUMENTATION

The PDP carries a wide range of instruments for the measurement of pressure, waves, fields, and particles. A discussion of these instruments and some of the preliminary results of the mission can be found in Shawhan et al. (ref. 3). Of interest for this discussion are the charged particle detectors, and to a lesser extent, instruments used to measure electric potential and the geomagnetic field in the vicinity of the Orbiter.

The Low Energy Proton and Electron Differential Energy Analyzer (LEPEDEA) is a curved plate detector capable of detecting ions and electrons with energies between 2 eV and 36 keV. It is nearly identical to instruments flown on ISEE-1 and ISEE-2. The energy resolution of LEPEDEA is $\Delta E/E = 0.16$, and 1.6 sec. is required for a complete energy scan. The LEPEDEA fields of view are shown in figure 1. The seven detectors are sampled simultaneously and together have a field of view of 6 degrees by 162 degrees.

*This work is supported by NASA/Lewis Research Grant No. NAG3-449



An electron fluxmeter is also included in the PDP for detection of electrons. This instrument samples the electron flux independent of energy ten times per second. The fluxmeter is directed opposite to the LEPEDEA. It has a wide field of view with low angular resolution.

Electric fields were measured by two 20 cm spherical probes separated by 1.6m. The average potential between these spheres was measured relative to Orbiter ground with a range of ± 8.2 v. When the PDP was extended on the RMS, this potential was a measure of the plasma potential in the vicinity of the PDP.

A triaxial fluxgate magnetometer was used to measure magnetic fields. The magnetometer sampled the magnetic field 10 times each second, along each of its 3 axes with a resolution of ± 12 mgauss.

THE JOINT PDP/FPEG EXPERIMENT

Joint operations between the PDP and the FPEG were conducted while the Orbiter was in a nose-to-sun attitude with a roll rate of twice per orbit (see figure 2). For the experiment discussed in this paper, the FPEG emitted a 50-mA, 1-keV, unmodulated electron beam. A total of eleven emissions occurred under both daytime and nighttime conditions and at various injection pitch angles with each emission approximately fifteen minutes in duration. During these injections, the PDP was deployed on the Orbiter RMS and moved about the Orbiter in an effort to locate the beam.

The primary instrument for location of the beam was an electron fluxmeter located on the opposite side of the PDP from the LEPEDEA. During the search for the beam, the fluxmeter was pointed downward toward the FPEG aperture in the Orbiter bay which left the LEPEDEA looking away from the electron beam. Because of this orientation, the LEPEDEA did not detect primary beam electrons. At times, however, the PDP was rotated through 90 degrees about its spin axis (see figure 1) which allowed the LEPEDEA to view a range of particle pitch angles including primary particles.

OBSERVATIONS

Because of changing Orbiter attitude (twice per orbit roll rate) and variations in the geomagnetic field over the course of an orbit, a wide range of injection pitch angles were observed. Calculations by J. Sojka of Utah State University show that for injection pitch angles greater than about 60 degrees (depending on the precise beam-orbiter orientation), the beam intercepted the Orbiter surface. At angles less than this the beam escaped. Qualitative analysis of charged particle and potential measurements made by the PDP support this analysis.

Ambient electrons (photoelectrons) were detected with energies up to about 80 eV during the day and 10 eV at night, while ions were seen at energies principally below 10 eV during both day and night. During beam injection at angles less than 30 degrees, intense fluxes of electrons were detected at energies up to the primary beam energy of 1 keV. Virtually no ions were seen at these times. Enhanced electron fluxes were observed at all points accessible to the PDP. However, due to the limited reach of the RMS, no measurements were made at distances greater

than 7m from the beam. For beam injection, at angles greater than 60 degrees, the measured ion and electron fluxes often resembled the flux seen with the beam off.

Measurements of Orbiter potential during small angle injection also differed from the ambient case. When the beam was off, the Orbiter potential relative to the nearby plasma remained $\leq \pm 8.2v$ consistent with $V \times B \cdot L$ (ref. 3). When the beam was injected at less than 30 degrees, the potential was offscale and positive, and dropped below the maximum measurable value of 8.2v only at the maximum distance from the beam of 7m. Potentials during large angle injections were generally nearer to those measured with the beam off.

The observations tend to support the claim that the beam did escape from the near vicinity of the Orbiter for small angle injection, but did not at larger angles. The enhanced electron flux and elevated potential associated with small angle injection may be due to escape of the beam. If this is so, the large angle conditions which were so similar to ambient conditions could be due to the electron beam impacting the Orbiter rather than escaping. In this case, almost all of the beam current is collected so that the disturbance is localized and the Orbiter does not need to charge.

Figure 3 shows the measured flux during one of these rotations which took place at a distance of 7m from the center of the beam. Since this distance is roughly twice the gyroradius of a 1 keV electron travelling perpendicular to the magnetic field, these measurements must be of electrons outside of the primary beam. The angles shown in figure 3 are the pitch angles of electrons as they were detected by the LEPDEA. Angles greater than 90 degrees correspond to electrons travelling down the field lines from the direction in which the beam was injected. Angles less than 90 degrees indicate electrons moving up the field in the same direction as the outgoing beam. Although pitch angles less than 30 degrees and greater than 140 degrees were not sampled, this figure seems to show a net return of electrons along the field lines from the direction in which the beam was injected indicating that more current returns from the upper hemisphere during upwards injection than from the lower.

Based on this preliminary analysis of measurements made during electron beam emission, it appears that the electron beam did escape from the Orbiter. These escapes induced positive Orbiter potentials, and were associated with enhanced fluxes of electrons. During escape of the beam, there is evidence that there was a net flow of electrons along the magnetic field from the direction in which the beam was injected.

REFERENCES

1. Winckler, J. R.: The Applications of Artificial Electron Beams to Magnetospheric Research. Rev. Geophys. Space Phys., 18, 659, 1980.
2. Pedersen, A.: Plasma Diagnostics by Electron Guns and Electric Field Probes on ISEE-1. Artificial Particle Beams in Space Plasma Studies, (B. Grandal, ed.), Plenum Press, New York.
3. Shawhan, S. D.; Murphy, G. B.; and Pickett, J. S.: Plasma Diagnostics Package Initial Assessment of the Shuttle Orbiter Plasma Environment. Accepted J. of Spacecraft and Rockets, 1983.

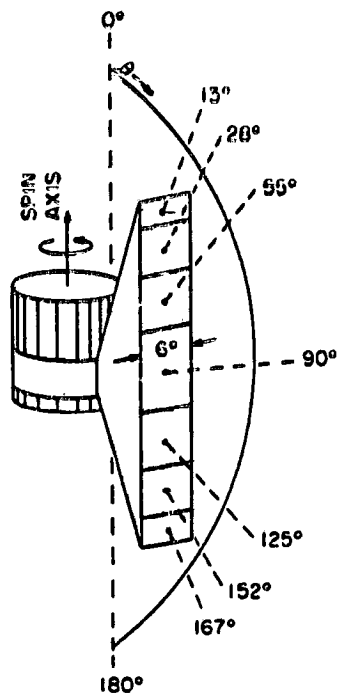

Figure 1. - LEPEUEA fields of view.

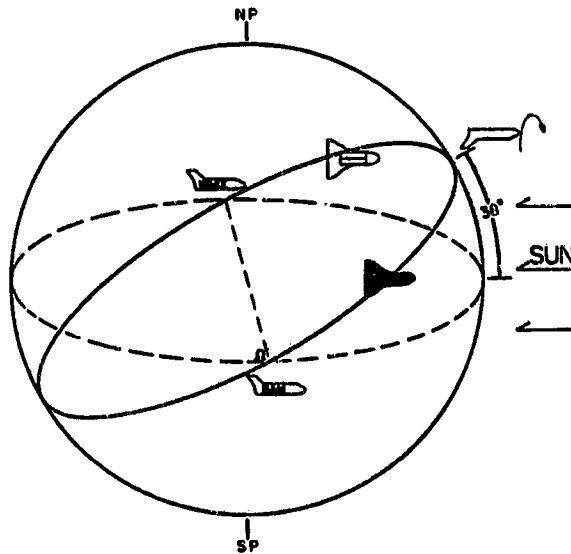

Figure 2. - STS-3 orbit attitude, March 24, 1982 - nose to Sun with twice per orbit roll rate.

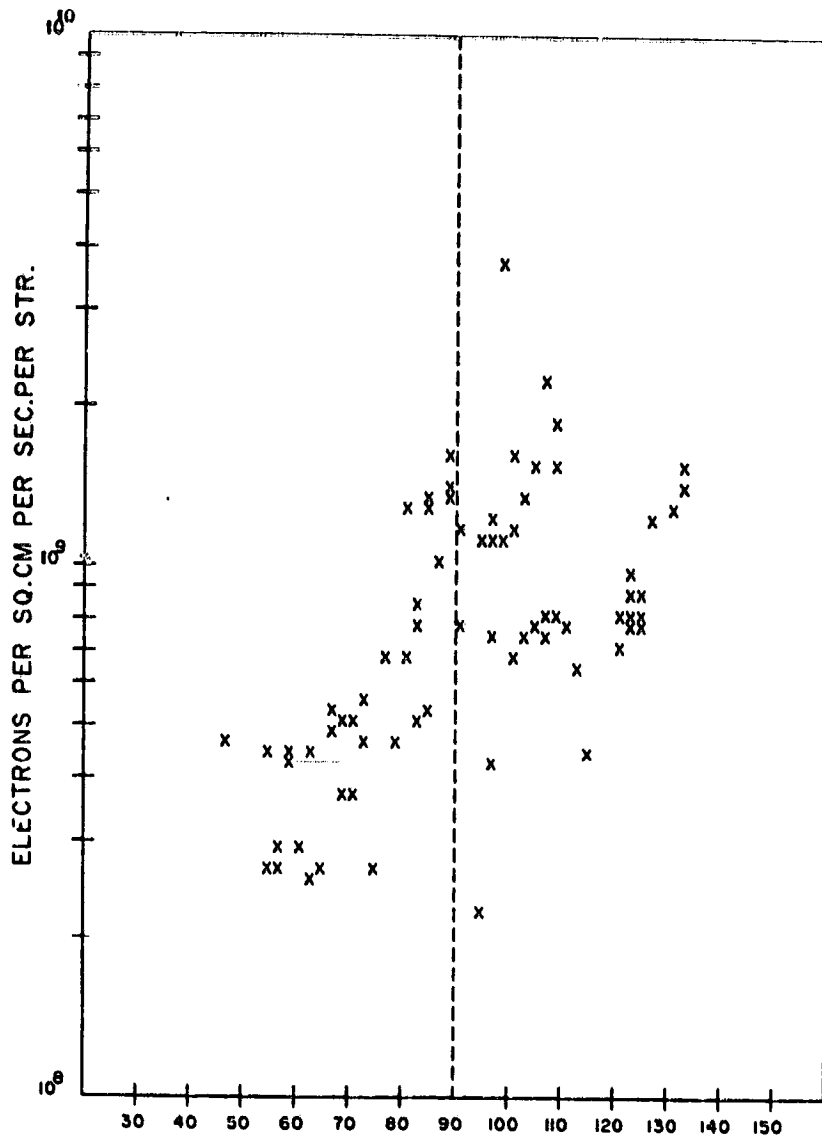

Figure 3. - Electron flux 7 m. from beam ($2 \text{ eV} < E < 36 \text{ keV}$).