

N85-16974

IN-FLIGHT TESTING OF THE SPACE SHUTTLE ORBITER
THERMAL CONTROL SYSTEMJ. Thomas Taylor
NASA Lyndon B. Johnson Space Center
Houston, Texas 77058ABSTRACT

The challenge of defining and successfully executing in-flight thermal control system testing of a complex manned spacecraft such as the Space Shuttle Orbiter and the considerations attendant to the definition of the tests are described in this report. Design concerns, design mission requirements, flight test objectives, crew vehicle and mission risk considerations, instrumentation, data requirements, and real-time mission monitoring are discussed. In addition, an overview of the test results is presented.

INTRODUCTION

The value and utility of a manned spacecraft such as the Space Shuttle Orbiter are enhanced greatly by its operational flexibility and capability to perform a multitude of varied and partly undetermined mission objectives. In this light, it was the initial design goal that the thermal design of the Orbiter be accomplished with minimum constraints with respect to vehicle attitude and time in attitude as well as power and weight.

The classical approach, whether for an unmanned or a manned spacecraft, is to define a thermal design mission which provides a design envelope and then to verify the design performance by ground testing to the extreme environments of the envelope, or by performing a simulated mission profile with minimal in-flight testing supported by analyses. This approach, however, was fostered in part by the fact that previous spacecraft were not reusable and a high degree of confidence in the design was necessary before committing to flight.

Program funding limitations and the fact that the Orbiter was a reusable spacecraft led to the consideration of in-flight testing for thermal design verification. At first glance, it would appear that this was a high-risk approach from a crew and vehicle safety standpoint as well as for mission success. Also of concern was the potential impact to the overall program schedule which might result if far-reaching design changes were necessary. However, systems redundancy, failure design requirements, and the capability to return to Earth in a short time minimized these risks. The overall test/verification approach and considerations which led to the total definition are described.

In-flight testing of the Space Shuttle Orbiter integrated thermal control design was successfully completed during the initial five orbital flights of the Space Transportation System (STS). The data base for verification of the thermal design to meet specified operational requirements was obtained with minimal ground tests through the definition and implementation of a comprehensive in-flight test program. Adequate data were obtained to either demonstrate capability or provide a data base for correlation of the vehicle- and subsystems-level thermal math models (TMM's) for analytical definition of the vehicle thermal performance capability.

TCS DESIGN OVERVIEW

The Orbiter thermal control system (TCS) is required to control and establish the thermal environments for all systems outside the crew module. However, certain systems that require internal thermal control as an intimate part of their operations are not included in the TCS. These are the fuel cells, the auxiliary power units (APU's) and cryogenic tank internal heaters, the active thermal control system Freon loop, the flash evaporator and steam ducts, and the hydraulic system water-boiler heaters.

The Orbiter TCS maintains subsystems and components within specified temperature limits for all mission phases (prelaunch, ascent, Earth orbit, entry, and postlanding). Integrated thermal control management is accomplished through use of fibrous and multilayer insulation (MLI) blankets, and available heat sources and heat sinks supplemented by passive thermal control (PTC) techniques such as coatings, heaters, thermal isolators, and, where practical, subsystems operating modes.

The basic insulation design consists of bulk fibrous insulation (TG-15000) sized to protect subsystems from overheating during entry and postlanding thermal soakback and supplemented by MLI for low weight, high thermal efficiency on orbit. The general vehicle-level application of bulk insula-

tion and MLI is shown in figures 1 and 2. A typical frame insulation installation is shown in figure 3, and typical fluid line applications are shown in figure 4.

Heater systems are used extensively as depicted in figure 5. These consist predominantly of two types: rope for fluid lines and patch heaters for area radiant heating and direct component heating such as aerodynamic control surface (aerosurface) actuators. A typical fluid line installation is shown in figure 6. Radiant heater designs are applied in the forward reaction control sys-

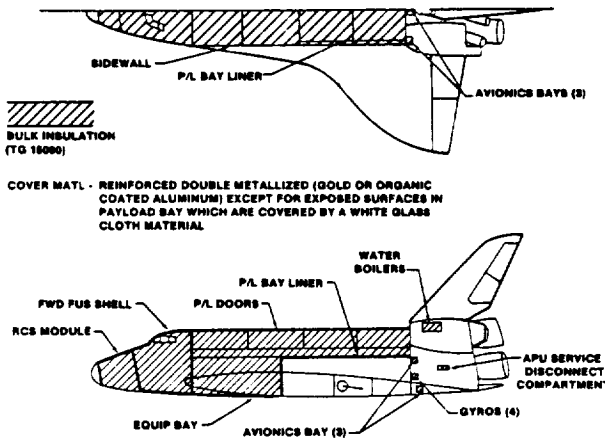

FIGURE 1.- THERMAL CONTROL SYSTEM BULK INSULATION.

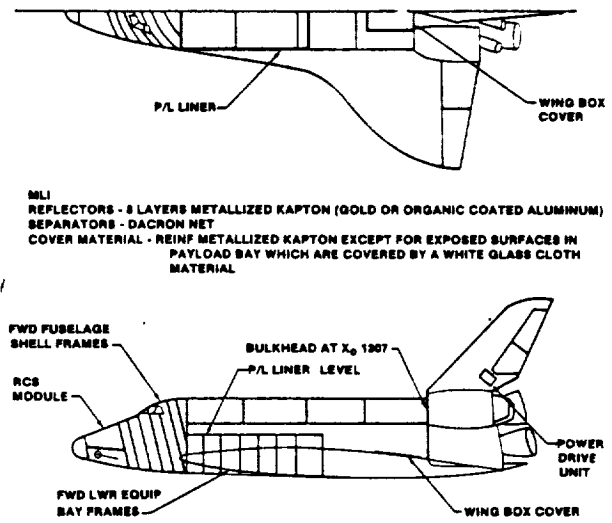

FIGURE 2.- THERMAL CONTROL SYSTEM MULTILAYER INSULATION.

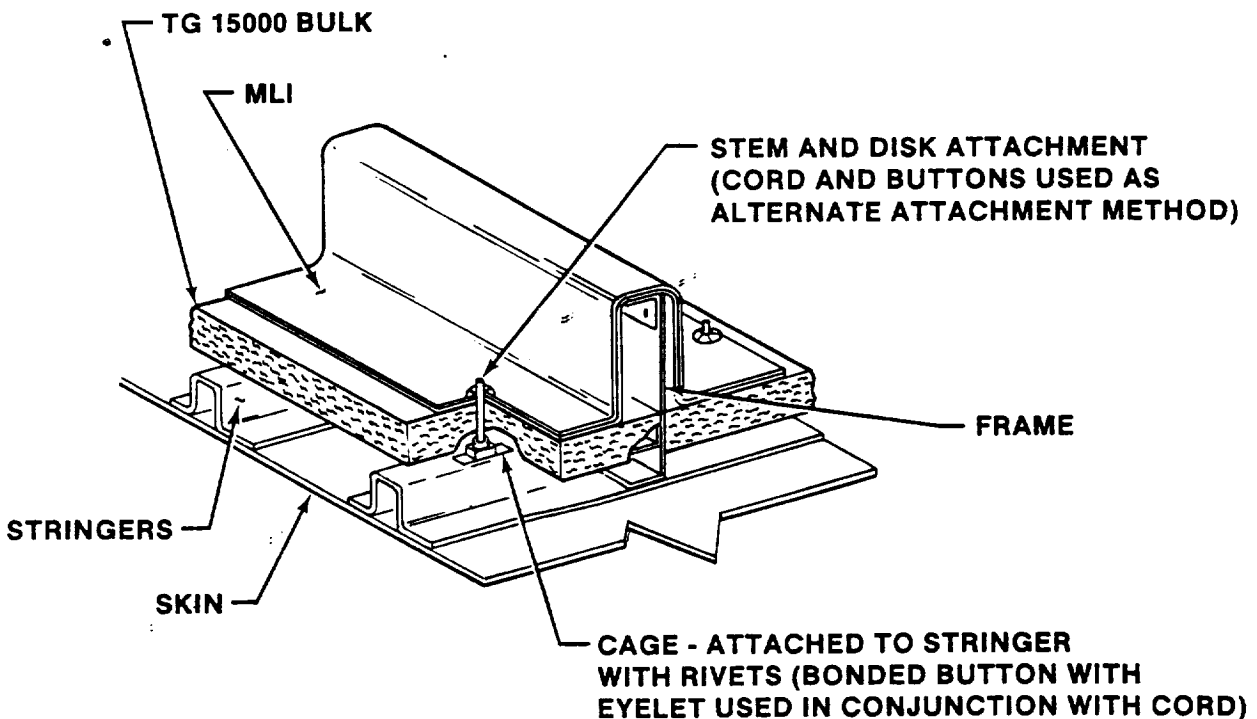
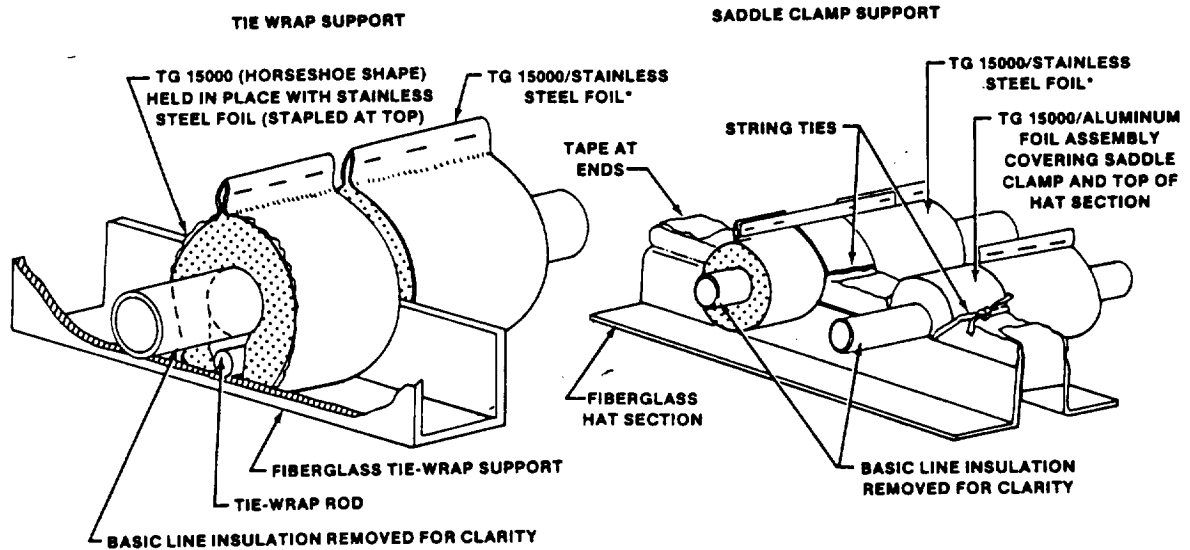

FIGURE 3.- TYPICAL FRAME SECTION MLI AND BULK INSULATION BLANKETS.

tem (RCS) compartment and the auxiliary propulsion system (APS) pods. The APS pod radiant heaters consisted of patch heaters applied to existing structural panels as depicted in figure 7. Most Orbiter heater systems are thermostatically controlled; exceptions are heaters required for special systems functions and operating modes, such as fuel cell purge line and vent heaters and main landing gear brakeline heaters, which are manually controlled.



*NEW VEHICLES SUBSTITUTE NONMETALLIZED POLYIMIDE FILM

FIGURE 4.- LINE INSULATION CONFIGURATION AT SUPPORTS.

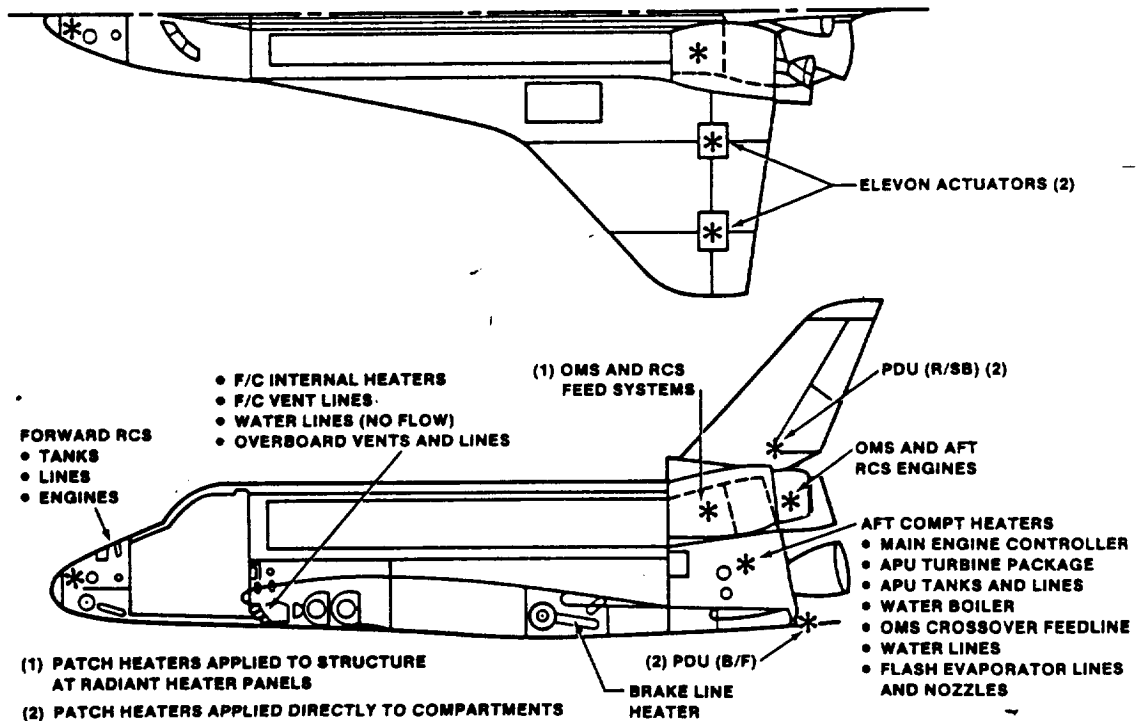

FIGURE 5.- ORBITER HEATER SYSTEMS.

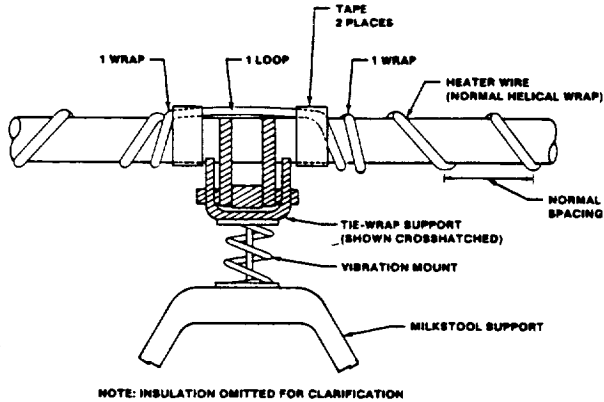

FIGURE 6.- TYPICAL HEATER INSTALLATION: LOCAL HEATING AT TIE-WRAP SUPPORT.

Except for drain lines and actuators, where heaters are applied for local thermal control, Orbiter hydraulic system temperatures are maintained on orbit by operation of circulation pumps which distribute the pump waste heat and heat picked up by way of a heat exchanger from the active TCS waste-heat-rejection loop to the various lines and components. The initial thermal requirement for the pumps was for prelaunch thermal conditioning of the main propulsion system (MPS) engine components and also for postlanding thermal conditioning to prevent local overheating of hydraulic system seals resulting from entry-heating soakback into the vehicle. On-orbit control of the circulation pump operation is achieved by a software thermostat mode driven by 40 temperature transducers located in the 3 hydraulic systems or by a computer-driven timer mode. In addition, specified movement of the aerosurfaces during main pump operations before entry interface is required to flush cold hydraulic fluid from stagnant lines and components to achieve full performance temperature levels during entry.

The vehicle-level air and gaseous nitrogen purge system (fig. 8) provides supplemental environment conditioning during prelaunch and postlanding phases. The primary thermal control function of the purge system before launch is to minimize heater usage and thereby to lower peak power requirements at lift-off and, in particular, to minimize stratification in the aft fuselage compartment during the MPS cryogenic chilldown conditioning and to raise the resulting compartment temperature levels. During the postlanding entry-heating-soakback period, the purge provides attenuation of the potential peak temperatures to which subsystems components would be subjected without the purge.

External vehicle surface coatings were dictated by thermal protection system (TPS) requirements for a black coating on the high-temperature reusable insulation and leading edges and a white coating on the low-temperature reusable insulation and felt (fig. 9). A white glass-fabric material was

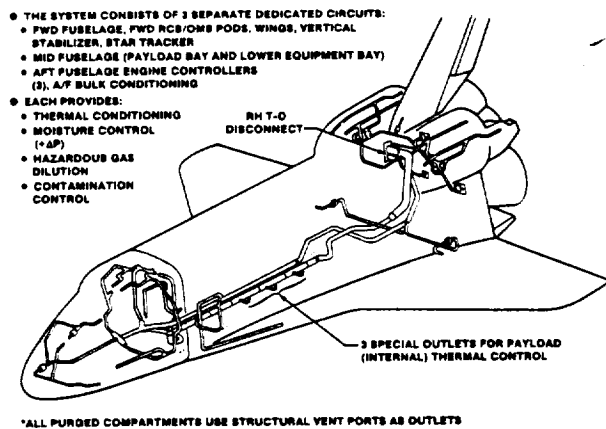

FIGURE 8.- PURGE SYSTEM, OV-102.

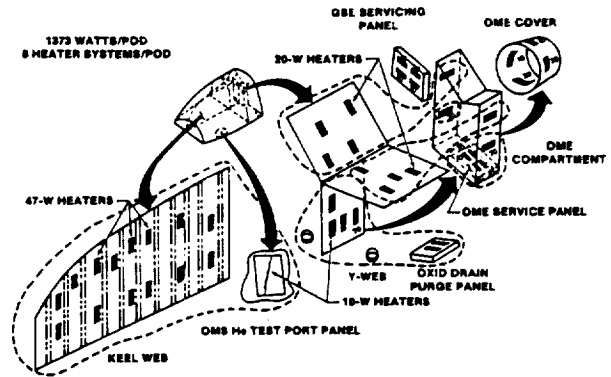

FIGURE 7.- APS POD HEATER AND THERMOSTAT ARRANGEMENT.

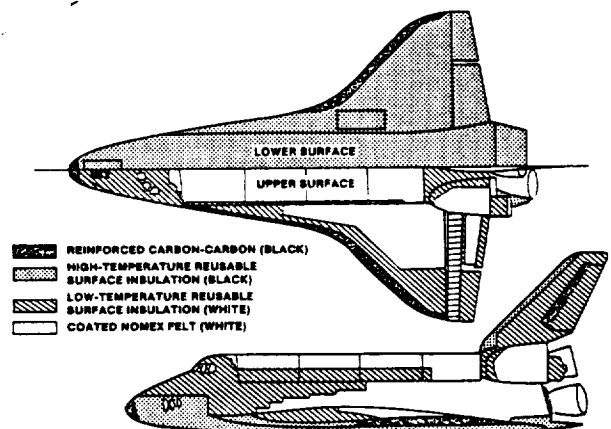

FIGURE 9.- OV-102 THERMAL PROTECTION SUBSYSTEM.

chosen for payload insulation blanket covers to reduce the effect of direct solar heating in the cavity and to provide acceptable temperatures for payloads. Internal insulation surfaces are metallized to provide a low emittance and thereby to reduce heat transfer to and from the structure.

THERMAL DESIGN MISSION

The initial thermal design mission definition for the Orbiter was quite simple; that is, provide adequate thermal design capability for the prelaunch, ascent, entry, and postlanding thermal environments and provide a 160-hour attitude-hold capability on orbit. The only constraints to the attitude-hold capability which evolved early in the Orbiter development were associated with preventing violation of the external TPS and structural bondline lower temperature and, in a hot case, providing preentry conditioning to cool the TPS bondlines below allowable maximum initial entry temperature levels.

The TPS bondline lower limit of -170° F could potentially be violated for any attitude which allowed continuous deep-space viewing. This possibility led to the requirement to limit such attitude holds to 6 hours followed by 3 hours of thermal conditioning before resuming the hold. This requirement applied only to attitudes that excluded solar or planetary exposure to a surface of the Orbiter during an orbit period. These attitudes were local-vertical orientations at high beta angles. A beta angle of 60° to 90° was chosen to define these orbital conditions. The beta angle is defined as the angle between the Earth-Sun line and the orbit plane.

During the course of the development program, additional attitude constraints were accepted by program management in lieu of design changes. These constraints are as follows.

1. Earth or solar viewing by the active thermal control system radiators is limited; the limitation varies dependent on water storage and power levels.
2. Tail to Sun attitudes are limited to 24 hours to prevent overheating of orbital maneuvering system (OMS) engine feedlines.
3. Nose, tail, and side Sun attitudes are limited to 33 hours to prevent violation of the main landing gear strut actuator and hydraulic dump valve lower limit of -35° F.

An additional requirement arose by which, for contingency early mission termination, thermal conditioning would be limited to 155 minutes and should not result in catastrophic conditions during entry or after landing. However, degradation in mission life would be accepted. The basic thermal design mission is outlined in figure 10; the basic thermal conditioning mode (PTC) and the beta angle (β) are illustrated.

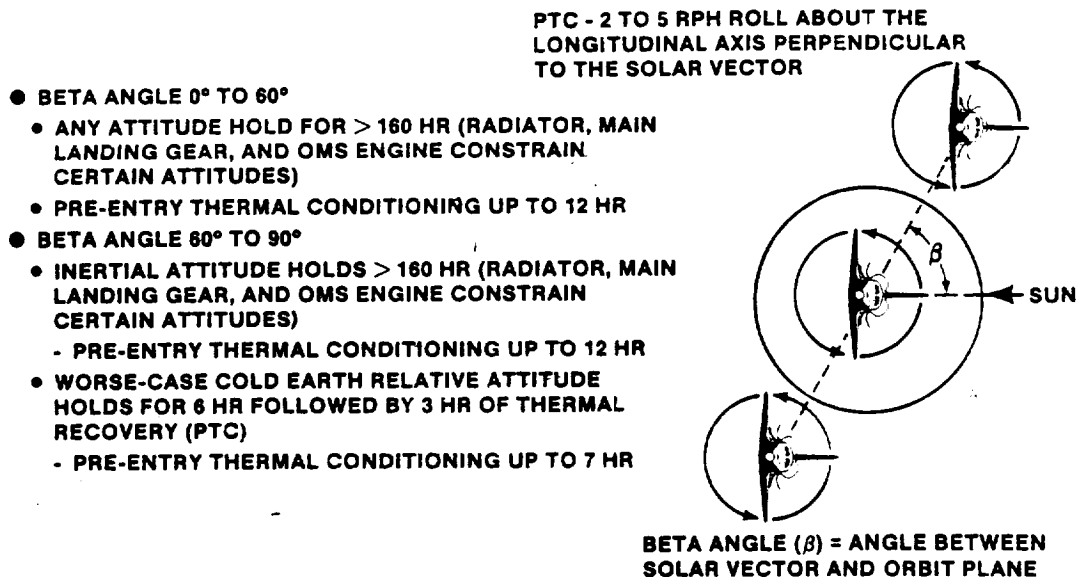

FIGURE 10.- THERMAL DESIGN MISSION PROFILE.

CONCERNS AFFECTING ON-ORBIT TEST DEFINITION

The initial program decision to consider in-flight thermal test and verification in lieu of ground thermal vacuum tests understandably caused much apprehension and concern. Verification by means of thermal ground tests and analysis supported by a minimum of in-flight testing was considered as the optimum technical approach. This conclusion was fostered in part by the design immaturity and unknown design problems at that time (late 1974 and early 1975).

Major concerns centered around (1) potential impacts to the thermal test time lines by other mission objectives, (2) the adequacy of flight instrumentation from the standpoint of quantity and location for both real-time anomaly identification and math model correlation, (3) the potential for early mission termination (mission success), (4) potential design changes which could impact the total orbital flight test (OFT) program, (5) commitment to flight by unverified analyses, and (6) the question of whether adequate thermal response for math model validation could be obtained. Ideally, the best approach for determining full capability and for providing sufficient data for math model verification and analytical extrapolations to actual flight design environments is to subject the vehicles and subsystems to the extreme hot and cold environments. This situation obviously is not desirable on initial flights from a crew or vehicle safety standpoint or for mission success. Basic advantages and disadvantages of ground thermal vacuum testing and in-flight testing were presented and summarized (tables 1(a) to 1(c)) along with the thermal vacuum test requirements (table 2).

Although Orbiter systems redundancy had a major impact in negating some of the basic risks and safety concerns, the potential of basic design flaws had to be faced in the design of redundant heater systems. A number of small fluid line heater tests were implemented to provide a level of confidence in the design approach. The in-flight tests, which are discussed later, were designed to minimize the impact of design flaws.

Other vehicle design features such as the caution and warning and the fault detection and annunciation (FDA) systems provide a method of defining systems failure redlines for early anomaly identification and resolution. These systems are used extensively for monitoring heater system performance. In addition, concerns over undercooling or overheating of RCS engines due to either heater system inadequacy or engine firing effects are minimized by an automatic deselect system.

VEHICLE MONITORING AND INSTRUMENTATION

Of major importance in any type of testing is the adequacy of the test instrumentation. As previously mentioned, this factor was a prime concern since a flight vehicle has inherent limitations as to the number of instruments that can be accommodated. In addition to the basic instrumentation needed to control operating modes of the various subsystems and to determine their general status, instrumentation was required to meet the objectives of the thermal flight tests. The overall verification and subsystem requirements which led to the definition of the flight test instrumentation are delineated in table 3.

Each subsystem area was reviewed for instrumentation to verify thermal math models for design-peculiar problems and for minimum real-time flight monitoring. The initial requirement was to add, to the existing 219 real-time operational flight instruments (OFI's) and 633 recorded development flight instruments (DFI's), 1460 new DFI's, of which 441 would be available in real time over the OFI system to support real-time monitoring and anomaly identification and resolution. This assessment was conservative but provided for the highest level of confidence in correlating math models for analytical design verification. However, such programmatic considerations as modifications, added costs, and schedule impacts inherent in accommodating this large amount of instrumentation on the vehicle suggested an alternate approach. Such an approach which would provide acceptable real-time monitoring capability but represented minimal instrumentation for math model verification purposes was presented and accepted. The former consideration affected to a great extent the definition of the flight test program, which is discussed later. It was agreed to add 410 DFI sensors to the Orbiter and to provide 410 data channels for real-time monitoring of selected existing and new DFI sensors. This addition brought the initial complement of real-time and recorded thermally related sensors to 629 and 633, respectively.

As a result of design changes and particular problems or concerns that arose during the design, development, and test phases of the vehicle, the number of real-time sensors approached 800. It was evident that such a large number of sensors could not be monitored adequately by means of manual plotting. Since no preflight data on vehicle thermal control performance were available to provide intelligence as to actual thermal response times or time to reach limits, it became evident that a real-time or near-real-time system of monitoring temperature response and trends was required. A summary of real-time monitoring requirements is presented in table 4. It was estimated that approximately 90 people (30 per 8-hour shift) with expertise in the thermal design area would be required

TABLE 1.- ADVANTAGES AND DISADVANTAGES OF
INTEGRATED GROUND THERMAL VACUUM TEST AND ORBITAL FLIGHT TEST

(a) Integrated ground thermal vacuum test

Advantages	Disadvantages
<ul style="list-style-type: none"> • Flexibility in varying and controlling known environment • High level of confidence • Early design verification • Minimizes program impact • Supports operational data book (ODB) • Provides flexibility in obtaining additional data as warranted by prior test phase results (test conditions and additional instrumentation) • Allows testing to extreme conditions (capability determination and failure simulation) 	<ul style="list-style-type: none"> • Test data will still require some interpretation and extrapolation to flight configuration and flight environments • Requires dedicated test articles or shared test articles with high potential for scheduling impact

(b) Orbital flight test

Advantages	Disadvantages
<ul style="list-style-type: none"> • Actual environment • Actual engine firings 	<ul style="list-style-type: none"> • Commitment to flight by analysis only • Crew time line impacted for thermal requirements • Determination of environment difficult • Large amount of instrumentation • Limited real-time data • Dedicated thermal flight test - Minimize impact from other mission objectives • Monitoring system for equipment duty cycles and power loads required • Insufficient intelligence for placement of instrumentation and heater controls • Insufficient intelligence to determine which instrumentation is required in real time • Dictates conservative flight test time line to avert potential problems (mission success, crew safety) • High probability of inadequate data (additional flight test required) • Questionable capability for real-time anomaly resolution and evaluation of flight plan changes • High program impact potential

(c) Summary

Test	Characteristic
Integrated thermal vacuum test	<ul style="list-style-type: none"> • Highly desirable for "no attitude constraints" thermal design • Mandatory for fixed-attitude/time-limit design if program does not provide dedicated thermal OFT and instrumentation or does not provide flexibility for more than one multiple-objective OFT with sufficient instrumentation • Minimum supplemental OFT instrumentation • Certification by test and analysis before flight
Orbital flight test	<ul style="list-style-type: none"> • Dedicated thermal OFT mandatory • Several flight tests required • High potential for large program impact • Greatly increased instrumentation and scar weight • Mission success questionable • Commitment to manned flight by analysis only

TABLE 2.- REQUIREMENTS FOR THERMAL VACUUM TESTS

● INTEGRATED THERMAL CONTROL SYSTEM VERIFICATION

- Functional verification of integrated subsystems, interfaces, and active/passive thermal control systems while exposed to extreme mission environments
- Subsystems qualification environment verification
- Flight operations support by demonstrating off limits and contingency operation of subsystems

● OBTAIN DATA FOR CORRELATION OF THERMAL ANALYTICAL MATH MODEL

- Certification analysis tool
- Mission planning tool
- Establish operational capability (operational data book)
- Real-time mission support tool

per flight to plot data and identify potential problems and to support real-time decision activities for problem resolution.

An interactive computer terminal system, or trend monitoring system (TMS), was instituted by which six terminals were provided for retrieval and plotted display of data in near real time. The number of terminals was determined by appropriate grouping of subsystems and major vehicle areas allowing the use of minimum personnel while not overloading a particular individual. Data were provided to the host computer by computer-compatible tapes (CCT's) obtained from the Mission Control Center network interface processor (NIP). The normal lag between real-time data and TMS data-base updates was approximately 2 hours. Use of an on-line printer enabled review and scanning of real-time cathode-ray tube (CRT) data displays by the thermal analysts. Data comparison with preflight prediction and previous flight data, data extrapolation, flight plan changes, and real-time anomaly investigations were supported by the real-time CRT data displays and TMS data sources, which proved to be a very effective combination. The real-time data flow and analysis is depicted in figure 11.

IN-FLIGHT TEST PHILOSOPHY AND APPROACH

As in the case of ground thermal vacuum testing, it would have been ideal from a thermal standpoint to subject the vehicle to design conditions immediately during the flight test program. This exposure would have the advantage of providing the best possible data for design verification as well as of minimizing the number of test conditions and the flight test time. However, as discussed previously, crew safety and mission success considerations were primary. Basic to these considerations was the demonstration of launch, orbit insertion, deorbit, entry, and landing capabilities and procedures. In addition, such an approach would require that critical procedures for payload bay door closure, TPS preentry thermal conditioning, and hydraulic system entry warmup as well as the wheel brakeline heaters (which are only used just before and during entry) would have to work properly the first time. With these considerations and concerns in mind, the philosophy was adopted to subject the vehicle initially to a benign thermal environment to allow identification of any gross design flaws and to minimize the potential risk and mission impact. The vehicle would, within the OFT program constraints such as launch schedules, number of flights, mission length, and payload requirements, then be subjected to increasingly more severe thermal environments on follow-on flights.

In line with the stated philosophy, it was necessary that such test requirements as environments, vehicle attitudes, and special tests be defined consistent with program constraints and still provide for in-flight capability demonstration or provide adequate data for correlation of TMM's to be used for analytical design verification. This need resulted in requirements for both low- and high-beta-angle flights. The distinction between high and low beta angles is that high beta angles (60° to 90°), depending on orbit altitude, approach or provide 100 percent sunlight conditions or no Earth shadow time as opposed to low beta angles. The rationale for low-beta-angle missions was as follows.

1. To provide benign environment for early identification of gross design inadequacies
2. To provide level of confidence in design to commit to more severe environments

TABLE 3.- THERMAL TEST INSTRUMENTATION

REQUIREMENT FOR ADDITIONAL THERMAL INSTRUMENTATION

- Integrated thermal control system verification
 - Obtain data for thermal math model correlation and subsequent verification by analysis
- Operational program support
 - Mission planning tool
 - Data source for ODB
 - Real-time mission support and contingency identification and resolution

INSTRUMENTATION IDENTIFICATION GROUND RULES

- Utilize vehicle/subsystems design symmetry and similarity to minimize number of measurements
- Identify critical areas required for real-time on-orbit monitoring to prevent contingencies

STRUCTURE/SUBSYSTEM REQUIREMENTS

- Tanks
 - Identify gradients caused by heaters and local environment
 - Determine heat gain/loss through mounts
 - Determine interaction with surrounding structure/subsystems
 - Determine heater sizing and controller location adequacy
- Lines
 - Identify cold spots and verify heater/insulation sizing and controller location
 - Determine heat gain/loss through mounts
 - Determine interaction with surrounding structure/subsystems
- Heat-generating equipment (fuel cells, APU, pumps, etc.)
 - Determine interaction with surrounding structure/subsystems (heat balance and heat distribution)
 - Verify design environments
- Insulation
 - Verify adequacy of performance in installed configuration
 - Verify design environments
- Structure
 - Verify subsystems design environments (boundary conditions)
 - Bondline measurements for preentry thermal conditioning, verify structural gradients
 - Verify cabin heat leak
- Hydraulics
 - Verify circulation loop flow balance and duty cycle required for on-orbit thermal control
 - Verify adequate temperature control during main pump operations
 - Verify heater/insulation sizing and controller locations for stagnant lines and associated components
- RCS/QMS engines
 - Verify engine firing soakback effects
 - Verify engine heater sizes/duty cycles
 - Determine heat gain/loss through engines
- MPS
 - Determine local cooling effects from cryogenic lines and effect of engine firing on aft fuselage subsystems
 - Determine effects of heat gain/loss through engine on aft compartment and subsystems
- Payload bay (PLB)
 - Verify effects of open doors on lower midfuselage components
 - Verify PLB environments
- PLB doors
 - Substantiate analytical design gradients as they affect door operations
 - Verify temperatures of seals and mechanisms
- General - Verify OFI and heater controller locations

TABLE 4.- REQUIREMENTS FOR REAL-TIME THERMAL FLIGHT DATA

- GENERAL - Provide intelligence for precluding, identifying, and resolving anomalous conditions in those areas where analysis and ground test data are inadequate for preflight verification
- SPECIFIC REQUIREMENTS
 - Adequacy of hydraulic circulation pump for on-orbit operation and preentry aerosurface actuator/power drive unit warmup
 - Monitor operation of subsystem heaters (heater sizing, controllers and OFI instrumentation location)
 - Monitor areas which constrain vehicle attitudes
 - Effect of OMS/RCS engine firing/soakback on subsystem components and interfaces
 - Requirement for and adequacy of preentry thermal conditioning of TPS/structure and related door closure components (seals, motors, etc.)
- THERMAL MONITORING REQUIREMENTS
 - Lack of test data and knowledge of vehicle/subsystems response characteristics and TCS design adequacy requires timely access to real-time data and playback (as available) in a readily available and usable form for evaluation and decisionmaking to:
 - Determine vehicle status
 - Identify/forecast potential or impending anomalous conditions
 - Recommend or concur on remedial actions or flight plan changes
 - Approximately 800 temperatures must be monitored
 - Additional data required (available from existing sources) - Vehicle Earth/Sun look angles, orbital position, systems configuration and operating modes, power loads, engine firing times, overboard dump time lines, and consumables usage history
- VEHICLE STATUS REQUIREMENTS
 - High and low limit flags
 - Thermal summary tabs - Quick scan of all real-time thermal data
- PROBLEM IDENTIFICATION/FORECASTING REQUIREMENTS - Real-time temperature history plots
 - Capability to select parameters and plot scale (real-time update and playback interleaved)
 - Storage and retrieval
 - Overlay/comparison of predicted and flight data
 - Vehicle-Earth/vehicle-Sun look-angle plots
- REMEDIAL ACTION/FLIGHT PLAN CHANGE REQUIREMENTS - Same as problem identification/forecasting
- WHY ARE NEAR-REAL-TIME PLOTS WITH INTERLEAVED PLAYBACK AND STORAGE RETRIEVAL CAPABILITY REQUIRED?
 - Manned Test - Requires timely recognition of impending problems and definition of alternative solutions
 - Lack of test experience - Unknown level of confidence in preflight analyses requires thorough understanding of available flight data be maintained at all times
 - Flight data will be the major tool for recognizing potential problems and recommending avoidance actions and flight plan changes
 - Time to reach limits - Transient thermal response, which is dependent on environment, heater size, and design, can only be obtained from plotted data
 - Data extrapolation for more than a few hours (depending upon response rate) is questionable
 - Volume of data - Volume of data cannot be efficiently managed, plotted, handled, or understood without adequate computer hardware/software support

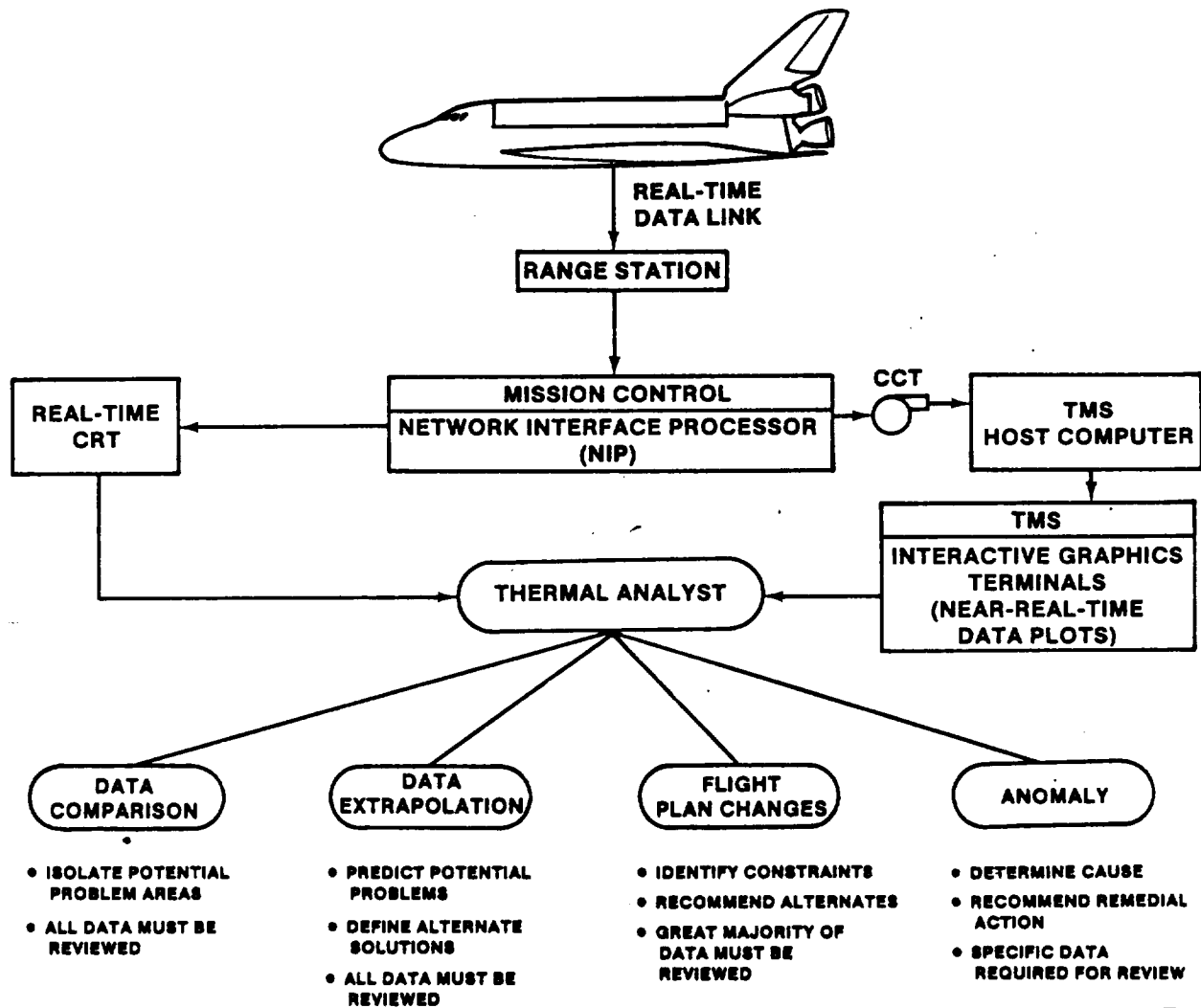

FIGURE 11.- REAL-TIME DATA FLOW AND ANALYSIS SCHEMATIC.

3. To gain level of confidence in analytical capability required for in-flight problem resolution and to support mission planning

4. Potentially inadequate data availability, both in sensor quantity and in sensor locations as well as that associated with long periods between ground station passes at high beta angles, requires previous flight test experience in support of anomaly resolution and mission planning

High-beta-angle flight requirements stemmed from the following.

1. Concern that temperature levels and the amplitude of transient responses at low beta angles would be inadequate for TMM correlation and analytical verification

2. Opportunity afforded at high beta angles to subject the vehicle or portions of the vehicle to extreme hot or cold conditions and provision of the best environments for TMM correlation or demonstration of design capability

FLIGHT TEST REQUIREMENTS AND TEST DEFINITION

The fundamental driver for test definition was to prove the thermal capability of the various

subsystems to meet the thermal design mission and to identify any existing constraints for the purpose of determining operational acceptability or redesign requirements and providing basic capability definition to support operational mission planning. To obtain the necessary test data, each system must be subjected to cold and hot environments during each mission phase to either demonstrate capability or correlate thermal math models. Since each vehicle compartment area with few exceptions can be treated as a box, the basic on-orbit test attitudes were defined to subject each side to hot and cold environments with variations dependent on peculiar subsystems and component test requirements.

In addition to determining environmental test requirements, it was also necessary to define specific systems functional tests to verify thermally sensitive operating modes. Initial test requirements and test definition were derived from the thermal design data-base analyses which identified vehicle and subsystem sensitivities. This process obviously was iterative since the overall thermal design was subject to the design maturity of other subsystems which affected the integrated thermal characteristics of the vehicle. A number of analysis cycles were required to update test requirements in addition to mission planning and actual preflight time-line analyses to arrive at the final test definition. The manner in which the various analyses are fed into the test definition and ultimately support the data correlation activities leading to the final TCS verification is shown in figure 12.

Prelaunch and ascent testing was basically a matter of obtaining data since systems operating modes are defined by launch operations and the external environment cannot be controlled. Likewise, systems test requirements, other than TCS, critical to entry defined the entry phase requirements. Each system was reviewed to determine data and test requirements for each mission phase. The general requirements are delineated in table 5.

Flight test requirements can be divided into two test groups.

1. Normal system operation and response to a given or specified environment
2. Operation of a system in a specified mode in a given or specified environment

Therefore, the first task in defining the flight test was to identify the required environments and vehicle on-orbit attitudes. Since the prelaunch, ascent, and entry phase environments and systems operating modes could not be varied to any great extent for TCS testing, the major portion of TCS tests was centered around the on-orbit phase. As discussed previously, it would have been ideal to subject the vehicle to extreme environments, which could be achieved by testing at high beta angles. This approach would also result in a minimum number of test conditions. However, in addition to the

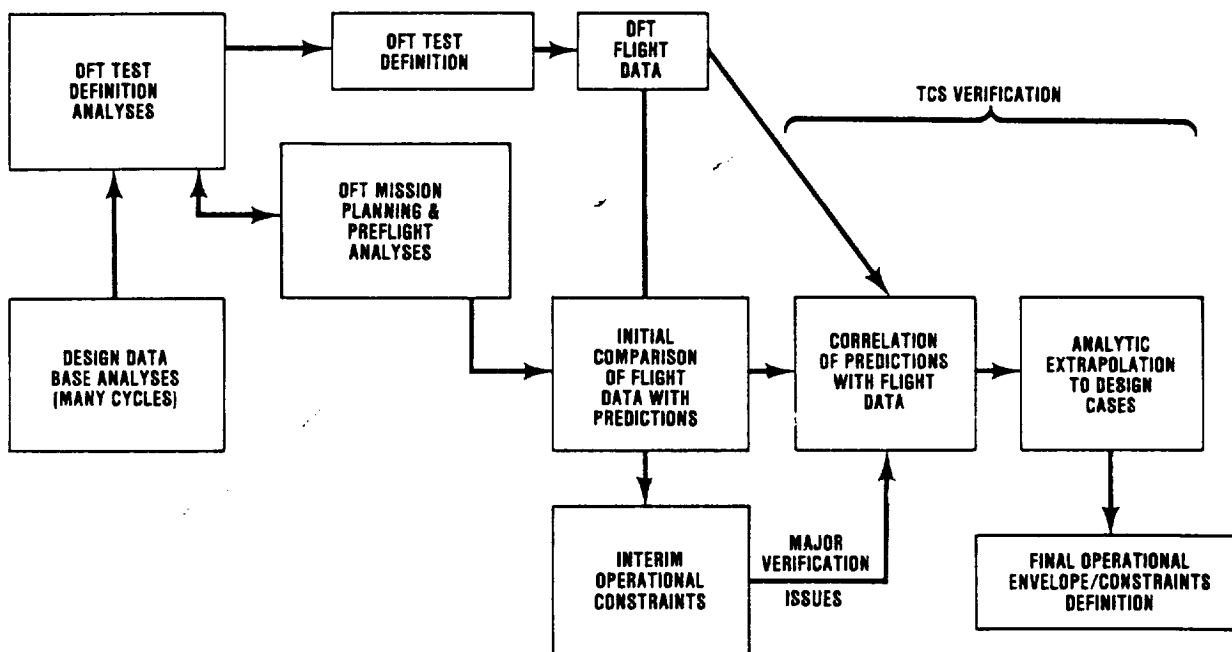

FIGURE 12.- TEST DEFINITION DETERMINATION.

TABLE 5.- SYSTEMS TEST REQUIREMENTS

1. GENERAL
 - a. Verify adequacy of heater system designs to maintain temperatures during all mission phases
 - b. Verify adequacy of insulation system in conjunction with the TPS to protect subsystems during aeroheating phases and postlanding entry-heating soakback
 - c. Verify that subsystem allowable environments are maintained during all mission phases
2. THERMAL PROTECTION SYSTEM
 - a. Define on-orbit cold attitude-hold capability and thermal conditioning requirement
 - b. Determine preentry thermal conditioning requirements to prevent violation of maximum allowable initial entry temperatures
3. STRUCTURES
 - a. Determine structural gradients to support entry and landing stress and loads analyses
 - b. Provide data to support determination of structural deflection effects on payload bay door (PLBD) closure and payload interfaces
4. HYDRAULICS
 - a. Verify adequacy of prelaunch hydraulic system thermal conditioning of main propulsion system
 - b. Verify adequate temperature control of hydraulic system during main pump operations for all mission phases
 - c. Determine adequacy of circulation pump on-orbit operation as a means of maintaining hydraulic system temperatures
 - d. Determine minimum preentry main pump operation and aerosurface actuator activity to achieve minimum full performance system and actuator temperatures
 - e. Determine postlanding circulation pump operational period to prevent local system overheating resulting from entry-heating soakback
5. RCS/OMS ENGINES
 - a. Verify that acceptable structure and subsystems temperatures are maintained following engine firings
 - b. Determine engine firing constraints (i.e., overheating or undercooling of engine components), if any.
 - c. Verify OMS engine feedline tail to Sun attitude-hold constraint
6. MAIN PROPULSION SYSTEM - Determine effect of main engine cryogenic chilldown during prelaunch and ascent and verify aft fuselage subsystem environments.
7. PAYLOAD BAY DOOR MECHANISMS
 - a. Verify that door latches, drive motors, mechanisms, and seals can be maintained within allowable temperature limits
 - b. Verify closure capability for various vehicle on-orbit attitudes
8. PAYLOAD BAY
 - a. Verify environment definition for payload integration for all mission phases
 - b. Verify adequate insulation performance at payload bay and lower equipment bay interface to maintain acceptable lower equipment bay subsystems environments
9. MAIN LANDING GEAR (MLG) - Verify or determine cold attitude-hold constraints envelope to prevent violation of strut actuator and hydraulic dump valve minimum allowable temperature
10. STAR TRACKER - Verify that hot and cold attitudes do not result in thermal distortions affecting star-tracker accuracy
11. PAYLOAD RETENTION FITTINGS
 - a. Obtain data for math model correlation to support payload integration analyses for definition of retention-fitting temperatures affecting payload and Orbiter interface loads
 - b. Determine preentry thermal conditioning requirements to prevent violation of specific payload retention-fitting minimum temperature allowables

concerns which guided the test philosophy, there were also flight schedules which dictated the capability to achieve high beta angles. Also, the number of test flights initially was uncertain.

Since the number of flights and the beta-angle conditions which could be achieved were uncertain, a matrix of attitudes and beta-angle conditions categorized as mandatory, highly desirable, and desirable was developed. This matrix formed the basis for defining flight tests which best fit the overall objectives for a given mission. Table 6 is a summary of test attitudes, purpose, beta angles, and hold time. The attitudes are defined in vehicle coordinates: -X nose, +X tail, +Z top, -Z bottom, +Y starboard side, and -Y port side. The attitude holds are defined as solar inertial (SI) or three-axis hold, Earth local vertical (LV), and orbital rate or single-axis inertial.

Passive thermal control, which consists of a continuous roll of 2 to 5 revolutions per hour about the X-axis with the X-axis perpendicular to the solar vector, and +ZLV (payload bay or top to Earth) for low beta angles were chosen as the most thermally benign attitudes to best satisfy the desire of minimizing the vehicle and subsystems thermal stress for the first mission. Also, PTC was chosen as a method of thermally conditioning the vehicle before entry to satisfy TPS initial entry requirements and before test attitude holds to minimize structural gradients and provide initial known temperature levels to minimize the error associated with initiating thermal math models for analyses and comparison with flight data. The +XSI, tail to Sun attitude provided a relatively cold environment for forward fuselage and midfuselage heaters, the hydraulics system, the star tracker, structural thermal deflection analyses (relating to payload bay door closure), and the main landing gear, as well as a hot condition for the OMS engine and aft RCS engine housing.

The -ZSI, bottom to Sun attitude provided a hot environment for TPS and structural heating, warm lower midfuselage systems environment, and structural gradients for thermal deflection analysis support. This attitude followed by PTC provided data for verification of the preentry thermal conditioning of the TPS bondlines to meet entry temperature constraints.

The +YSI, starboard side to Sun attitude subjects one OMS pod to a relatively hot environment and the other (port) pod to a cold environment to obtain heater performance data. Other objectives were to obtain side-to-side gradients to support thermal deflection analyses and to obtain additional main landing gear constraint data. The -XSI attitude with the nose pitched up 10° immediately following the +YSI attitude provided for a prolonged port OMS pod cold soak, which was desired, and provided data to verify the Sun-angle envelope associated with the main landing gear constraint.

The main objective of the pure -XSI (nose to Sun) attitude was to obtain data on aft fuselage systems and heaters in a cold environment, to verify another portion of the expected main landing gear cold attitude-hold constraint, hydraulic system response, and to provide a moderately warm environment for the forward RCS compartment. A secondary objective was to obtain additional OMS pod heater performance data.

Two attitudes, tail to Sun with top to space orbital rate roll followed by 3 hours of PTC for three cycles and pure tail to Sun with top to space orbital rate roll, were identified as candidates to provide the best data for cold TPS bondline, payload bay environment, and payload retention-fitting thermal response as well as to provide data on the cold main landing gear and hot orbital maneuvering engine (OME) line constraints. The +ZSI (payload bay to Sun) attitude was identified to support verification of payload maximum environments, payload retention-fitting warmup response, and star-tracker performance in a hot environment, and to provide additional data for structural thermal deflection analysis for top-to-bottom thermal gradients which affect payload bay door closure. This attitude also provides the best environment for K_U -band antenna performance in a hot environment, whereas the +XSI (nose pitched down 15°) attitude would provide for the best K_U -band antenna performance in a cold environment.

Two additional attitudes of lower priority, +YSI (side to Sun) with payload bay of +Z-axis rolled 40° toward the Sun and +XLV (nose to Earth) as described in table 6, were identified for flight tests if they could be flown with minimal impact. The attitudes categorized as mandatory represent the minimum set of data required for TCS verification. Beta-angle ranges were identified as shown in table 6 as acceptable, highly desirable, and no requirement. This tabulation provided a guide for determining the most appropriate mission for planning specific tests. As can be seen, the highly desirable category fell mainly in the high-beta-angle range since this range provides the opportunity for actual demonstration of capability with minimum reliance on thermal math model correlation to data at lower beta angles. Attitude-hold periods were best estimates, based on analyses, of time required to approach steady-state structural temperatures.

The second task was to identify subsystems functional tests for verifying thermally sensitive operating modes. The subsystems test objectives and test attitudes are summarized in table 7. These tests required specific crew activity to implement particular subsystems operations which would not normally occur.

TABLE 6.- THERMAL TEST MATRIX

Generic attitude (given in Orbiter structural body coordinate system)	Purpose	Attitude demo require- ment during O/T	Beta angle and approximate time requirements ^a		
			Low beta (0° to 45°)	Moderate beta (45° to 73°)	High beta/ 100% Sun (>73°)
PTC	Benign env and initial conditioning before any mission thermal attitude sequence	M ^b	AC (10 hr)	A	HD ^d
+ZLV (top Earth, X on Y)	Benign env Earth viewing	M	A (72 hr)	NR ^e	NR
+XSI (tail Sun, SI)	Cold att for fwd RCS, star tracker, PLBD closure, and hyd. MLG constrained attitude	M	A (80 hr)	A	A
	Hot OME lines at high beta	M	No reqn't	No reqn't	NA ^f (40 hr for OME lines)
-ZSI/PTC (bott Sun, SI/PTC) sequence mandatory	PLBD closure, warm bott structure/recovery to below design entry interface temps	M	A (40/10 hr)	A	HD ^f
+YSI (STBD side Sun, SI)	APS htr demo, nonsymmetric attitude for hyd and PLBD. MLG constrained att	M	A (40 hr)	A	HD
-XSI (nose Sun, SI)	Cold att for mid, aft, and APS htr systems and hyd. MLG constrained att	M	A (80 hr)	A	HD
-XSI (nose up 10°)	Same as above, only colder for APS pod htrs and an MLG constraint envelope limit	M	A (40 hr)	A	HD
6/3 demo (tail Sun, top space orb rate for 6 hr. Then, 3 hr PTC, then repeat cycle 2 more times with final PTC of 10 hr, i.e., 6/3/6/3/6/10)	Cold bondline constraint, deep-space viewing, PLBD closure, coldest PLB liner, cold P/L attachments	M	No reqn't	A (34 hr)	HD ^f
+ZSI (top Sun, SI)	Hot PLB and warm overall Orbiter; warm star tracker	M	A (40 hr)	A	HD ^f
	Hot K _u -band antenna ^g	(g)	No reqn't	No reqn't	HD (=20 hr)
+YSI top rolled towards Sun 40°	MLG constraint envelope limit	HD	HD (40 hr)	A	A
Tail Sun, top space orb rate	Cold bondline constraint, deep-space viewing at moderate beta, cold PLB liner, cold P/L attachments	HD	No reqn't	HD (20 hr)	No reqn't
+XLV (tail Earth LV)	Benign or possibly cold bondline constraint at moderate beta	D ^h	NR	D (20 hr, $\beta \leq 60^\circ$)	No reqn't
+XSI (nose down 10°)	Cold K _u -band antenna ^g	(g)	A (75 hr)	A	A

^aThe assignment of categories (mandatory, highly desirable, acceptable, etc.) relative to beta angle is based solely on analysis and subject to change as later data become available. Time (duration) requirements depend on attitude sequences to some extent. (See note following footnotes.)

M^b = mandatory.
CA = acceptable.

HD^d = highly desirable.

NR^e = not required if mandatory, highly desirable, acceptable, or desirable category achieved.

^fAdditional risk in overall certification may exist if these attitudes not demonstrated at high beta angle.

^gIf K_u-band antenna is not installed during O/T flights, generic demonstration attitudes similar to these are required after O/T (unless adequate ground thermal vacuum testing occurs).

D^h = desirable.

NOTE:

- ATTITUDE SEQUENCES: (1) It is highly desirable that the -XSI, nose pitched up 10° attitude follow the +YSI attitude to provide a long combined APS heater system demonstration.
(2) It is highly desirable that the -ZSI/PTC sequence and the +ZSI attitude follow a cold vehicle attitude (such as +XSI or -XSI) to demonstrate vehicle warmup from cold conditions.

TABLE 7.- SUBSYSTEMS FUNCTIONAL THERMAL TESTS

Subsystem	Test objective	Test attitude
Payload bay doors	<ul style="list-style-type: none"> ● Demonstrate door closure capability ● Determine effect of structure thermal deformation in various attitudes ● Determine any constraints to payload bay door closure 	<ul style="list-style-type: none"> ● PTC (benign), +ZLV (benign), +XSI, -XSI, +ZSI, -ZSI, and +X to Sun with +Z to deep space orbital rate
RCS engines	<ul style="list-style-type: none"> ● Obtain RCS engine continuous and duty cycle firing thermal data to support analytical definition of any firing constraints which might exist (9 tests total) 	<ul style="list-style-type: none"> ● Forward engines - +XSI, -ZSI, or +ZLV ● Port aft engines - -XSI, -ZSI, +YSI, or +ZLV
OMS engine	<ul style="list-style-type: none"> ● Obtain thermal response data to assess thermal soakback effects on engine components and Orbiter structure and subsystems 	<ul style="list-style-type: none"> ● Port engine - -XSI, +YSI, or +ZLV
Hydraulics	<ul style="list-style-type: none"> ● Operate each hydraulic system circulation pump to obtain independent thermal performance data (no thermal interaction test) ● Operate all three hydraulic systems sequentially to obtain interactive thermal performance data (3 systems interaction test) ● Demonstrate circulation pump operation in the software thermostat mode in a benign environment (single system thermal test) ● Obtain data to verify aerosurface actuator cycling as a viable technique for obtaining operational hydraulic fluid temperatures to provide proper actuator response during entry aerodynamic operations (entry thermal conditioning) ● Provide data to verify the automatic software timer mode operation of the hydraulic circulation pumps 	<ul style="list-style-type: none"> ● +ZLV (benign) ● +ZLV (benign) ● +ZLV (benign) ● +ZLV or postentry inter-face period following a benign attitude ● +XSI (tail to Sun)
Star tracker	<ul style="list-style-type: none"> ● Obtain data in nonoperating and operating modes under hot and cold environmental conditions to determine thermal effects on star-tracker accuracy 	<ul style="list-style-type: none"> ● +ZSI (top Sun) +XSI (tail Sun)
Flash evaporator system feedwater lines	<ul style="list-style-type: none"> ● Inhibit flash evaporator operation to obtain line heater performance during a period of fixed cold bias environmental conditions with no waterflow 	<ul style="list-style-type: none"> ● -XSI (nose to Sun)
Potable water and wastewater dump lines and nozzles	<ul style="list-style-type: none"> ● Obtain data during a defined water dump period in a cold bias environment to verify line and nozzle heater performance 	<ul style="list-style-type: none"> ● -X or +XSI
K _U -band antenna	<ul style="list-style-type: none"> ● Post-OFT, obtain data in the heater-only mode in both cold and hot environments followed by a defined period of operation in the minimum and maximum heat dissipation operating modes, respectively, to verify thermal performance 	<ul style="list-style-type: none"> ● +XSI, nose pitched down 15° (cold) ● +ZSI, top Sun (hot)

AS-FLOWN OFT THERMAL TEST PROGRAM

As the OFT program solidified, it became evident that the high-beta-angle tests could not be accomplished within the designated four flights. In conjunction with this limitation, program management recognized that a number of tests would have to cascade into the post-OFT or operational phase of the Space Shuttle Program. As a result, it became necessary to identify post-OFT test requirements and instrumentation at an early stage for the purpose of defining and implementing instrumentation hardware requirements and to facilitate mission planning.

In light of the concerns over the adequacy of low-beta-angle data for verification, it was decided to fly as many of the mandatory tests as practical during OFT at low beta angles, even though the high-beta-angle tests were more desirable, and to define a critical set for post-OFT testing at high beta angles. This approach would allow getting the plan in place to assure adequate verification but would also allow cancellation of the post-OFT tests if the data from the first four flights proved to be adequate.

The first Space Transportation System flight (STS-1) was flown in a +ZLV attitude with the tail or +X-axis on the velocity vector to provide the desired benign environment. Program payload commitments prevented accomplishment of TCS attitude tests during the STS-2 flight, which was flown in a +ZLV attitude with the nose or -X-axis on the velocity vector as required by the payload. However, scheduling changes for delaying removal of flight test instrumentation until after the fifth flight (designated as the first operational flight) enabled accomplishment of the four flight test programs in the first five flights.

In figures 13(a) to 13(c), STS-3 to STS-5 test attitudes are shown. The attitudes chosen for STS-3 were PTC for thermal conditioning before and after the first attitude hold of +X (tail to Sun with top to space) orbital rate roll followed by -XSI (nose to Sun) and +ZSI (top to Sun). It should be noted here that, contrary to the initial categorization shown in table 6, the continuous +X to Sun

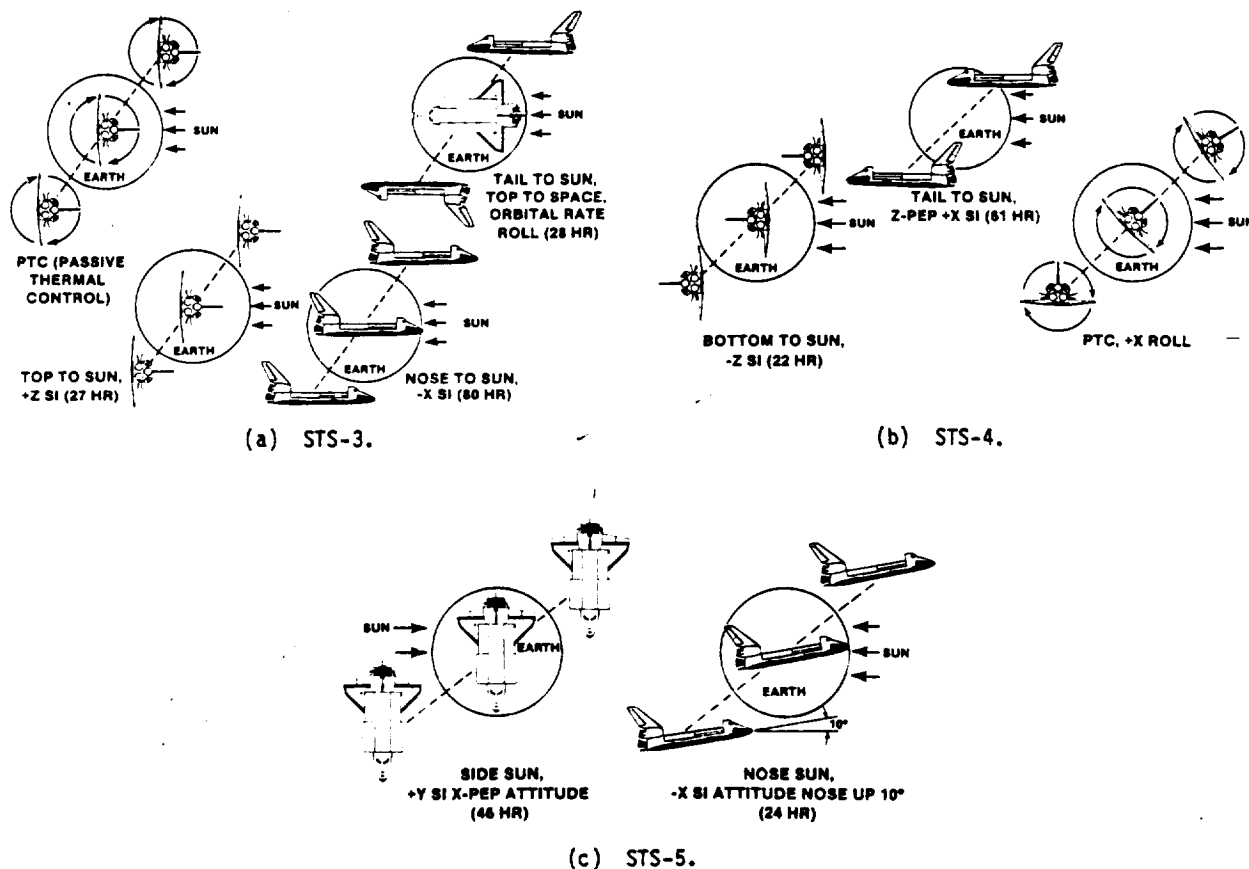

FIGURE 13.- THERMAL TEST ATTITUDES.

orbital rate roll test condition was chosen over the three cycles of 6 hours of +X orbital rate roll followed by 3 hours of PTC test condition. It was determined that a continuous hold would provide better response data for TPS bondlines and the payload bay, for the beta angles that would be encountered, than would the cyclic test condition. The +XSI (tail to Sun) and -ZSI (bottom to Sun) attitudes followed by PTC were flown on STS-4. The STS-5 test attitudes were +YSI (starboard side to Sun) followed by -XSI (nose to Sun) pitched up 10°. In figure 14, simplified attitude time lines flown on STS-1 to STS-5 are shown.

In general, the TCS test attitudes were flown as planned. An exception was STS-4, during which it was determined that an unacceptable quantity of moisture had been ingested by the TPS tiles and bakeout of the tiles was required. This determination resulted in reversing the attitude profile sequence from +XSI and -ZSI followed by PTC to +ZSI, PTC, and +XSI. Loss of data for thermal response of the black TPS tiles from a cold to a hot condition resulted.

Four test attitudes were designated as post-OFT test requirements: +ZSI, +XSI, -ZSI followed by PTC, and the cyclic 6 hours of +X to the Sun with -Z to Earth orbital rate roll followed by 3 hours of PTC. The post-OFT tests and objectives are summarized in table 8. Since the Ku-band antenna would initially be flown in benign environments in the post-OFT period and in light of ground thermal test results, it was determined that the two test attitudes, +ZSI and +XSI (nose down 15°), for the Ku-band could be treated as demonstration tests when convenient. All systems functional tests were completed with the exception of the OME engine firing tests, one of nine RCS engine firing thermal soakback tests, the potable water and wastewater dump tests, and two payload bay door closure tests. In addition, three hydraulic system tests were abbreviated and redefined as a result of STS-2 being shortened from 5 days to approximately 54 hours because of a fuel cell failure (table 9).

The OME firing and water dump tests were deleted since adequate data were obtained as a matter of course. In the case of the OME firing, the requirement was reevaluated because of propellant

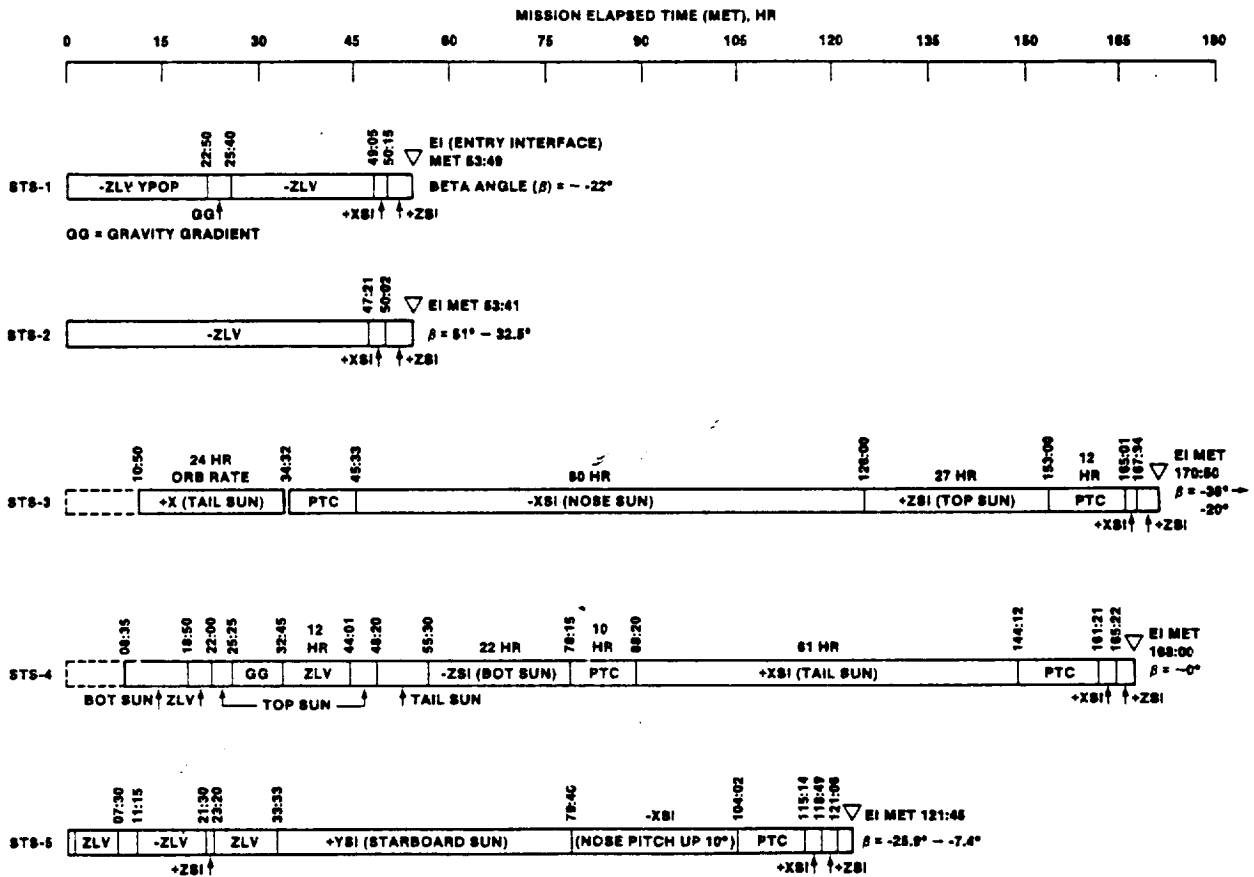

FIGURE 14.- STS FLIGHT TEST ATTITUDE TIME LINE.

TABLE 8.- POST-OFT TCS HIGH-BETA-ANGLE FLIGHT TESTS

Vehicle attitude	Primary test objectives
+ZSI (top to Sun)	<ul style="list-style-type: none"> Hot payload bay environment verification Determine effects of hot payload bay on lower midfuselage subsystems environments Payload bay door (PLBD) closure demonstration
+XSI (tail to Sun)	<ul style="list-style-type: none"> Identify and define OME propellant feedline hold constraint to prevent exceeding maximum allowable operational temperature Demonstrate ML6 cold attitude-hold capability PLBD closure demonstration
6/3 attitude cycle	<ul style="list-style-type: none"> Define cold TPS bondline constraint Cold payload bay, cold environment verification and obtain payload retention-fitting thermal response data
-ZSI (bottom to Sun) followed by PTC	<ul style="list-style-type: none"> Demonstrate maximum TPS bondline temperatures and thermal conditioning recovery required to cool to maximum allowable initial entry temperature levels Determine effects on lower midfuselage subsystems environments

TABLE 9.- TCS FUNCTIONAL TEST ACCOMPLISHMENTS

Test planned	Flight				
	STS-1	STS-2	STS-3	STS-4	STS-5
Payload bay door closure	<ul style="list-style-type: none"> +ZLV 		<ul style="list-style-type: none"> +X orbital rate (re-quired thermal conditioning to close and latch) -XSI +ZSI 	<ul style="list-style-type: none"> -ZSI (re-quired thermal conditioning to close and latch) +XSI (deleted real time) 	<ul style="list-style-type: none"> +YSI (deleted)
RCS engine firings			<ul style="list-style-type: none"> -XSI (2 tests) 	<ul style="list-style-type: none"> +XSI (3 tests) -ZSI (1 test deleted) 	<ul style="list-style-type: none"> +YSI (2 tests) -XSI pitched up 10° (1 test)
Hydraulics		<ul style="list-style-type: none"> +ZLV (3 tests redefined real time for shortened mission) +ZLV 		<ul style="list-style-type: none"> +XSI 	
Star tracker			<ul style="list-style-type: none"> +ZSI -XSI 	<ul style="list-style-type: none"> +XSI 	
Potable water and wastewater dump lines and nozzles				<ul style="list-style-type: none"> Deleted (data obtained from flight 3) 	
Vernier RCS engine heater test		<ul style="list-style-type: none"> +ZLV (added following STS-1) 			
APU fuel and water line thermal response with heaters "off"				<ul style="list-style-type: none"> +ZLV 	

availability. The RCS engine firing, a 100-second continuous burn of the aft-firing port engine, was deleted in real time as a result of other mission conflicts and was not rescheduled. A program management decision was made during the STS-4 mission to discontinue actual closing and latching of payload bay doors in the thermal test attitudes. However, thermal data and structure deflection measurements were obtained to support payload bay door verification.

Two functional tests were added during the OFT program. As a result of in-flight evidence that the forward vernier RCS engine heaters appeared to be incapable of maintaining temperatures above those indicative of leaking propellant valves during prolonged nonfiring periods, a special test was defined and performed on STS-2 to provide engine thermal response with the engines inhibited. Results of the test proved that either a hardware redesign or operational procedures would be required. The second test resulted from concern over "failed on" APU fuel line heaters overheating the fuel lines during entry and posing a safety hazard. The only immediate solution would be to inhibit the heaters; therefore, a test of the fuel line thermal response with heaters inhibited was implemented on STS-4 to determine whether the lines would freeze before landing. This problem is discussed in the following section.

FLIGHT TEST RESULTS OVERVIEW

The data presented herein are intended as an overview only for completeness of this report. Detailed evaluation, correlation of thermal math models, and TCS analyses to verify the Orbiter design are expected to be complete approximately 1.5 years following completion of the required TCS tests.

The primary prelaunch concerns were with the aft fuselage cooldown associated with the main propulsion system cryogenic propellant effects, which normally occur approximately 4 hours before launch when initial filling and conditioning of propellant lines within the aft fuselage begins. The aft fuselage prelaunch thermal model which was correlated to main propulsion system ground test data provided very good predictions for the actual vehicle. Bulk gas and structure temperature predictions were a maximum of 14° F warmer than actual prelaunch data (table 10).

On-orbit structure and TPS bondlines generally were warmer in flight than predicted. Figures 15(a) to 15(c) are comparisons of STS-3 flight temperatures with preflight predictions for two representative forward fuselage locations and one OMS pod TPS bondline location. Maximum deviations are on the order of 30° F. It can also be seen that the structure transient thermal response tends to be slower than predicted. In figure 16, the large gradients between the starboard (+Y) and port (-Y) midfuselage sides experienced during the +YSI attitude on STS-5 are shown.

Most Orbiter heater systems performed better than predicted as would be expected in light of the warmer structure temperatures experienced. In instances in which heater duty cycles were greater than predicted, the increase was not of a magnitude that would cause alarm. Design performance acceptability will be determined in the verification program. Exceptions were the forward vernier RCS engine and forward RCS compartment radiant heater panels.

TABLE 10.- SUMMARY OF AFT FUSELAGE ANALYTICAL PREDICTIONS
VERSUS STS-1 DATA BEFORE LIFT-OFF

Aft fuselage location	Temperature, °F	
	STS-1 data	Preflight predictions
Forward bulk gas	66	70
Mid bulk gas	43	53
Aft bulk gas	35	40
Fuselage port sidewall	47	44
Fuselage starboard sidewall	40	43
Fuselage bottom centerline	40	43
Base heat shield	32	46

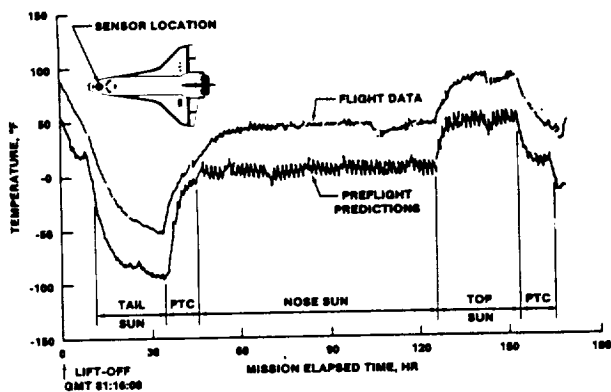

(a) FORWARD FUSELAGE TOP.

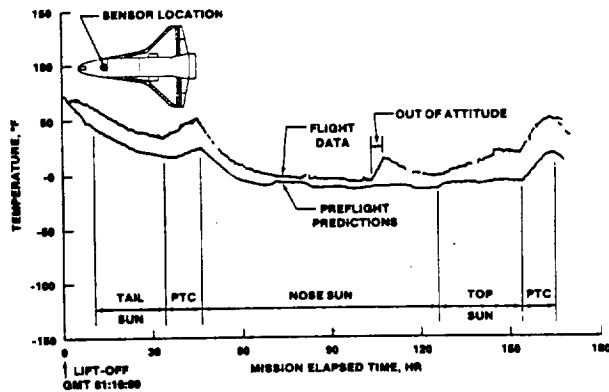

(b) FORWARD FUSELAGE BOTTOM.

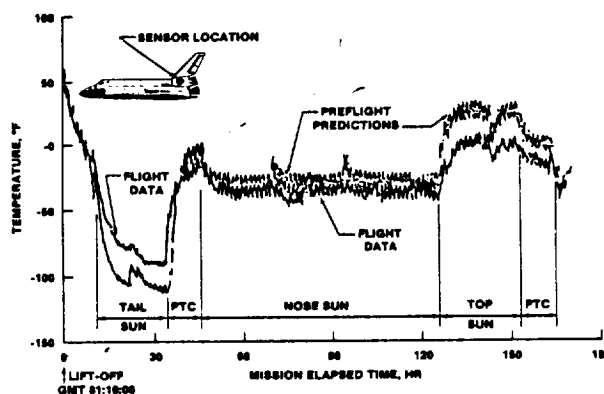

(c) PORT SIDE OMS POD.

FIGURE 15.- STS-3 ON-ORBIT STRUCTURE TEMPERATURE PROFILE.

During a 4-hour period on STS-1, the vernier RCS engines were inhibited from firing. The engine heaters exhibited a 100-percent duty cycle, and temperatures continued to drop until the engines were enabled to fire. Data from STS-1 were inadequate for analysis; therefore, a test was implemented on STS-2 for a prolonged nonfiring period to obtain heater response data. In figure 17, the response of the port and starboard vernier engine oxidizer injector tubes, which are indicative of heater performance and are also used for leak detection, is shown. The differences in temperature response and heater "on" times result from the fact that, because of the moderate beta angle and +ZLV attitude being flown, sunlight was impinging on the port engine. The decrease in starboard engine temperature continued after the heater activated, and the temperature reached the engine valve leak detection limit of 130° F in approximately 5 hours 45 minutes after engine firing was inhibited. Inspection of engine installations revealed higher than expected conduction shorts and increased radiation losses.

Also on STS-1, the forward RCS compartment radiant panel heaters exhibited a 100-percent duty cycle until they were disabled for entry (fig. 18). The heaters had been predicted to function initially at a mission elapsed time (MET) of 16 hours as compared to an actual time of 35 hours 20 minutes at a duty cycle of 25 percent. Inspection of the thermostat installation disclosed that the propellant line bracket next to the thermostat was made of aluminum rather than fiber glass and was attached to an RCS purge and drain panel, which was more closely thermally coupled to the vehicle cold structure than had been calculated. The increased conduction and the high radiant view factor from the thermostat to the panel caused the high heater duty cycle. The initial concerns were that overheating of RCS system components could occur and that an unnecessary amount of power was being consumed. However, further analyses and flight data showed that overheating would not be a problem, and the increased power usage did not justify a redesign.

Failed-on APU fuel line heaters during entry would require a crewman to deactivate the failed heaters during a high crew activity period and therefore was undesirable. To negate this possibil-

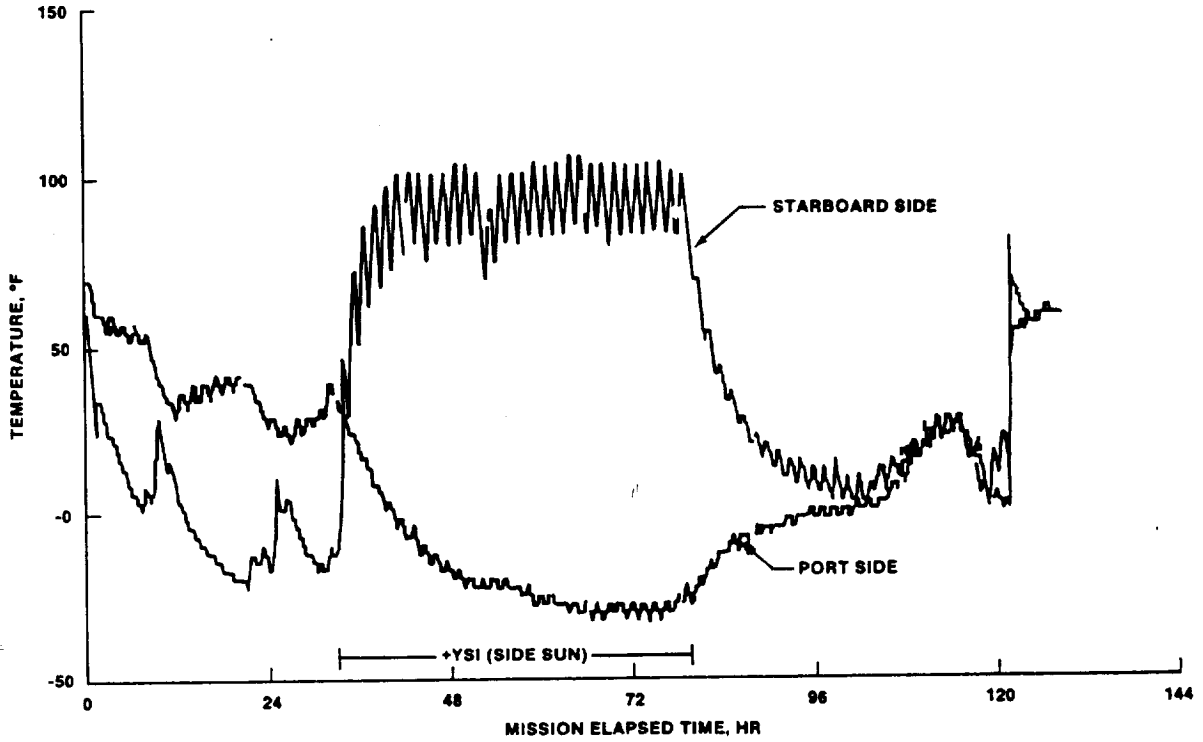

FIGURE 16.- STS-5 MIDFUSELAGE SIDE BONDLINE TEMPERATURE PROFILE.

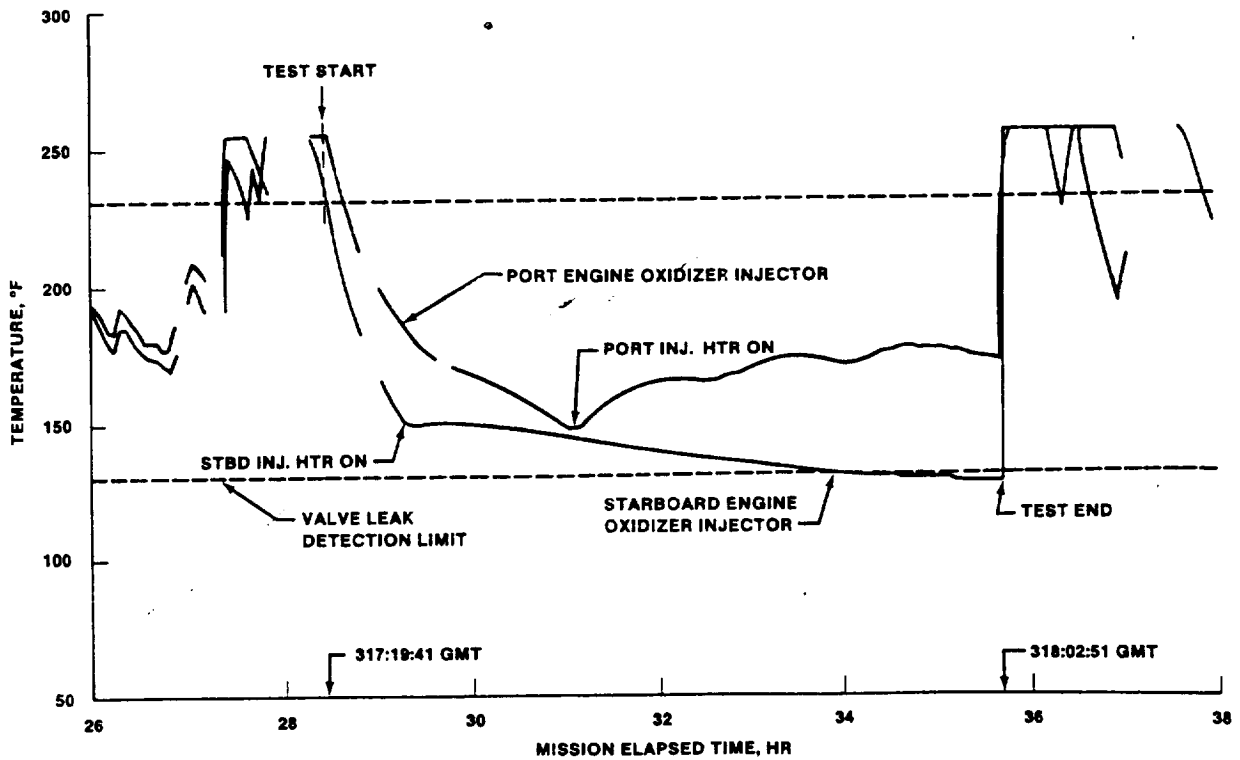

FIGURE 17.- STS-2 VERNIER RCS ENGINE HEATER TEST.

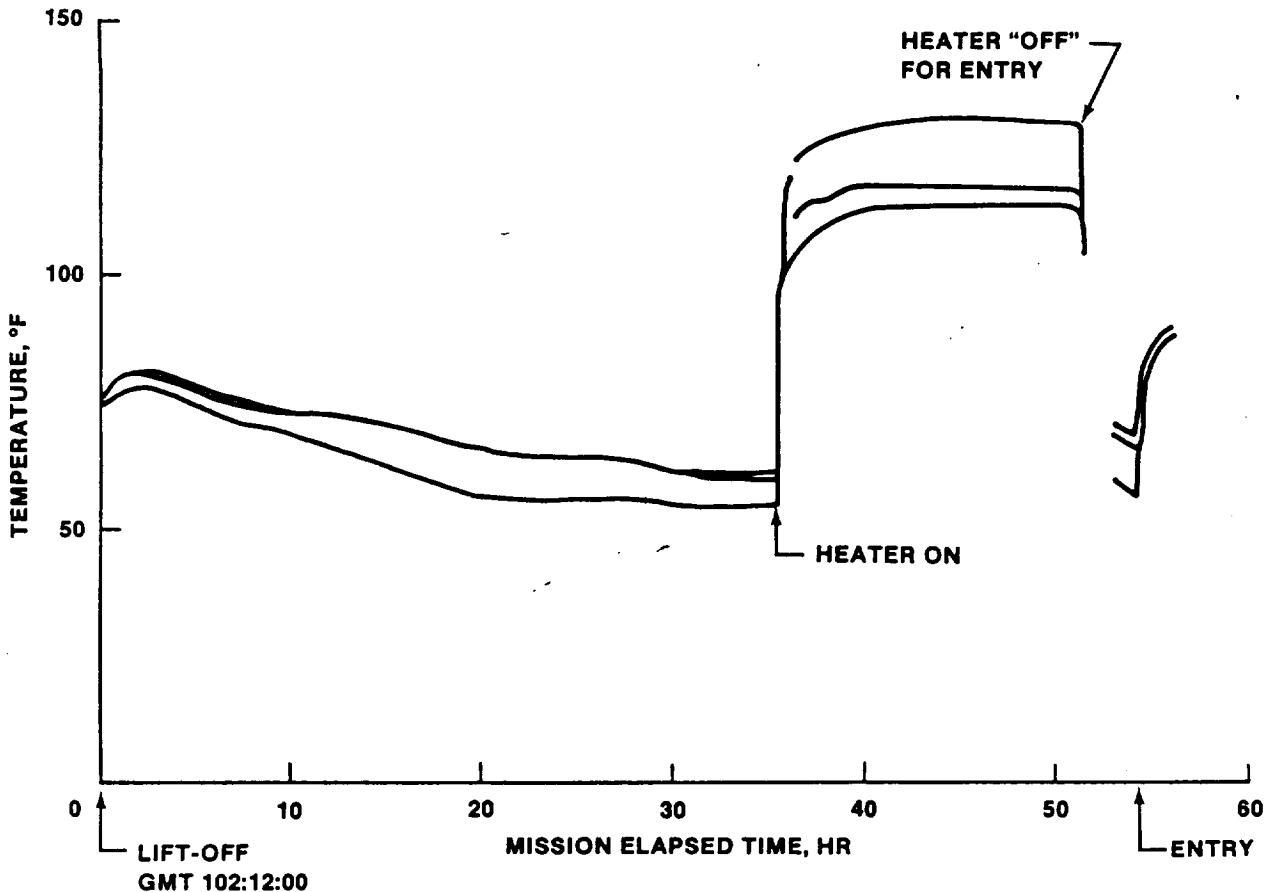

FIGURE 18.- STS-1 FORWARD RCS COMPARTMENT PORT HEATER PANEL TEMPERATURE PROFILE.

ity, it was desirable to determine whether the heaters could be deactivated before entry without freezing before ground power hookup after landing. A test was conducted on STS-4 by deactivating the heaters in an environment representative of that expected just before entry. In figure 19, the cooldown response of three locations on the APU 1 fuel service line is shown. It can be seen that the coldest location, curve 1, near the thermostat would reach the APU fuel freezing temperature of 35° F in less than the 3 hours desired by flight operations and would require crew intervention. Therefore, the heaters were not deactivated for entry.

The first data for determining the tail to Sun attitude-hold constraint for the OME feedlines were obtained on STS-3 during the 24 hours of +X to Sun orbital rate attitude. Temperature of the engine feedlines reached 110° F at the end of the hold and was still increasing. Extrapolation of the flight data indicated that the equilibrium temperature for the moderate beta angle that was flown would have been 120° F if the attitude had been held longer. This indication was verified during the 67-hour +XSI attitude hold on STS-4, in which the oxidizer line temperature reached approximately 120° F (fig. 20). Results of preliminary analyses indicate that the lines will exceed the 145° F limit for engine firing at beta angles exceeding 60°.

As expected, STS-4 provided the best data for supporting definition of the main landing gear strut actuators and hydraulic dump valve cold attitude-hold capability. The actuators and dump valves reached minimum temperatures of -24° F and -28° F (-35° F minimum allowable), respectively, at the end of the 67-hour +XSI attitude hold. The flight and predicted response for the strut actuator is shown in figure 21. Thermal model correlation and analyses will be required to define the constraint envelope.

The first flight data on the adequacy of running the hydraulic system circulation pumps on orbit as a means of maintaining fluid temperatures above the minimum limit of 0° F were returned on STS-2. A typical hydraulic line (system 2 body flap) response to a series of approximately 20 minutes "on,"

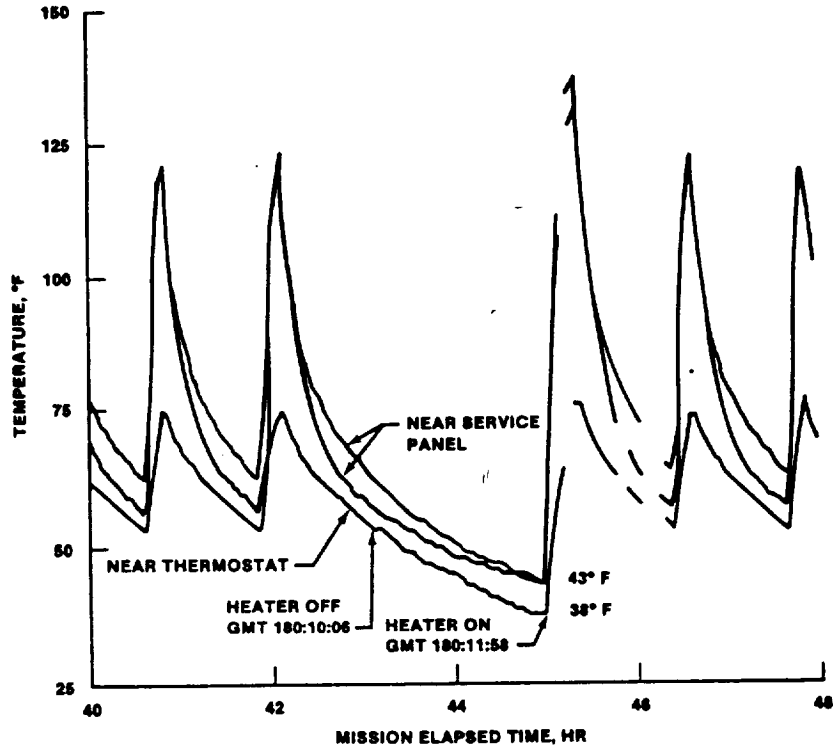

FIGURE 19.- STS-4 APU 1 SERVICE LINE TEMPERATURE PROFILE.

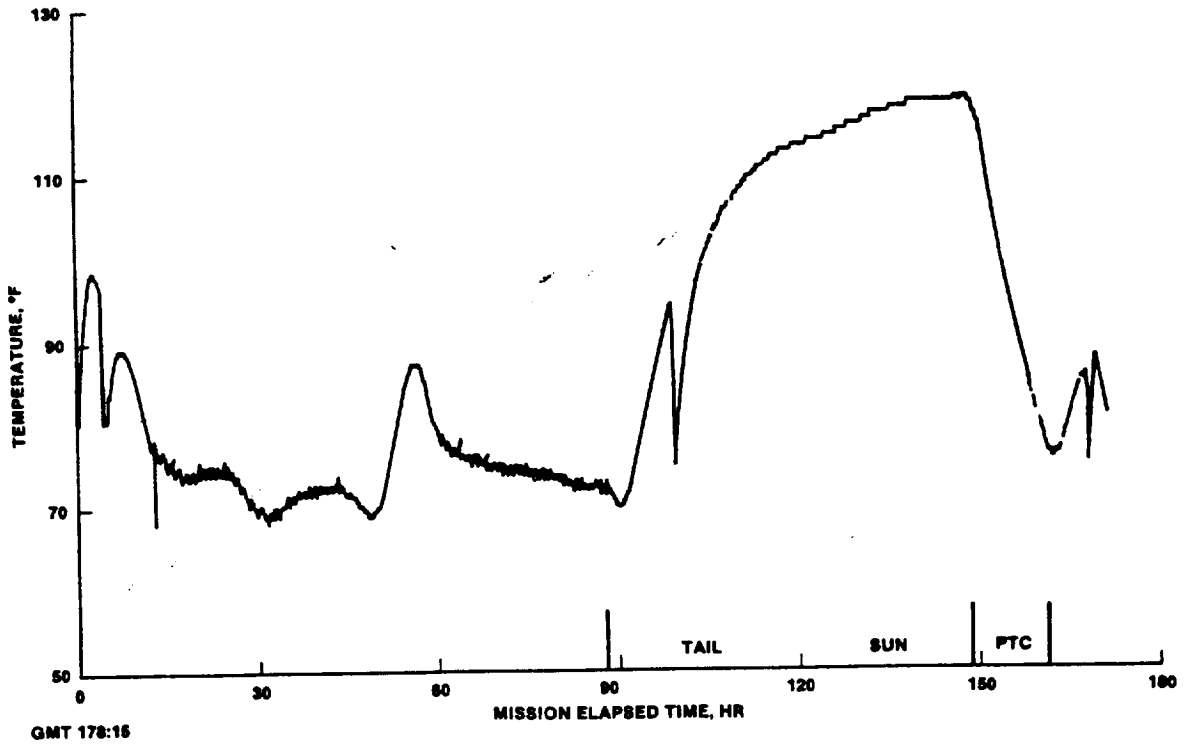

FIGURE 20.- STS-4 PORT ONE OXIDIZER LINE TEMPERATURE PROFILE.

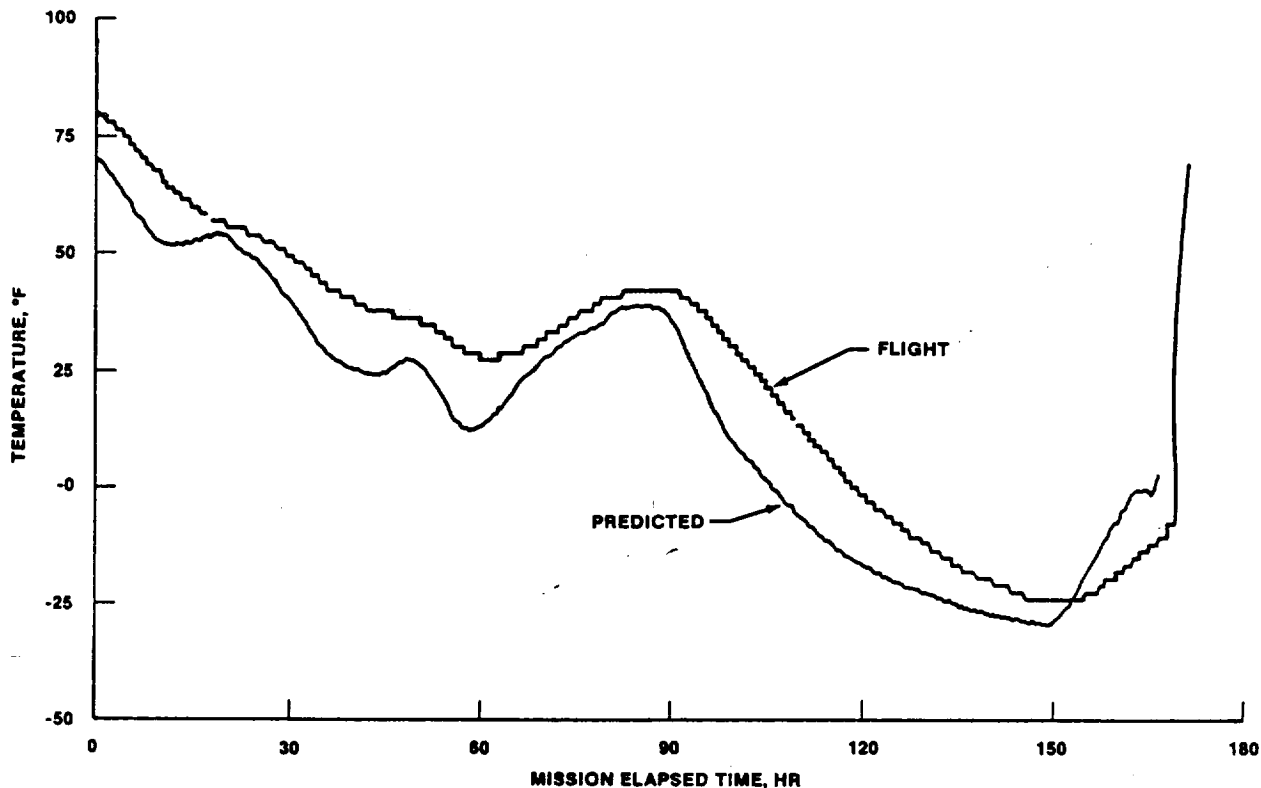

FIGURE 21.- STS-4 STARBOARD MAIN LANDING GEAR STRUT ACTUATOR TEMPERATURE PROFILE.

45 minutes "off" cycles (manual operation by the crew) is compared with predictions in figure 22. It can be seen that the temperature rise rate and levels are higher than predicted. Follow-on flight results have shown required pump duty cycles to be much less than predicted.

The thermal response of a forward primary RCS engine during and after a 30-second continuous test firing on STS-4 is shown in figure 23. Shown are the oxidizer and fuel injector tube and oxidizer valve temperatures. The cooling effects of propellant flow and postfiring propellant evaporative cooling can be seen beginning with the initiation of the firing at 142 hours 47 minutes MET followed by a temperature rise as a result of thermal soakback after the firing. The data provide a portion of the data base for thermal model correlation used to define any potential engine firing constraints.

Entry and postlanding thermal soakback effects on subsystems were minimal for the first five flights. Detailed analyses will be required for hotter entry environments than those flown. However, no problems are anticipated.

POST-OFT TESTING

During the course of the first five test flights, it became evident that the quality and the fidelity of the flight test data were much better than expected. More importantly, the TCS design appeared in most areas to exhibit greater margins and capability with respect to specified requirements when compared to preflight uncorrelated analytical predictions. A recommendation was made and accepted by the program management to accept the data from the first five flights as a basis for design verification. Also, except for some minor tests to investigate design differences between vehicles, the post-OFT TCS tests were deleted.

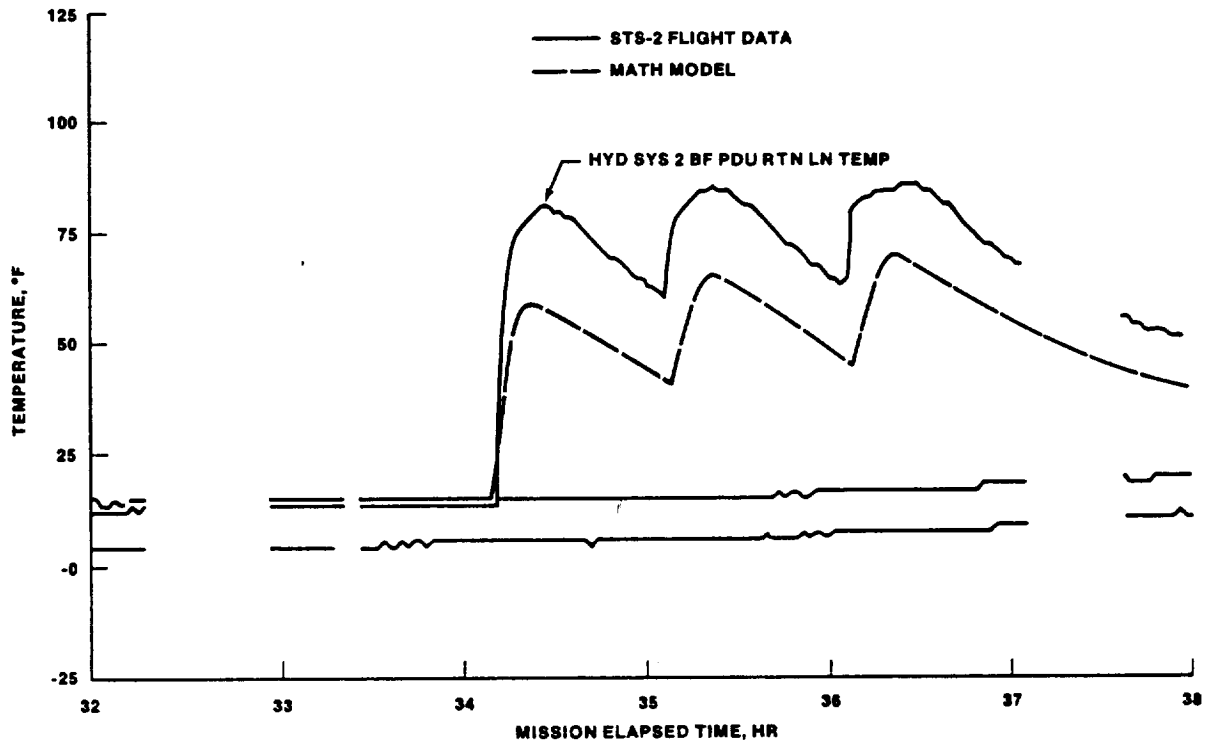

FIGURE 22.- STS-2 BODY FLAP OUTBOARD RETURN LINE TEMPERATURE PROFILE.

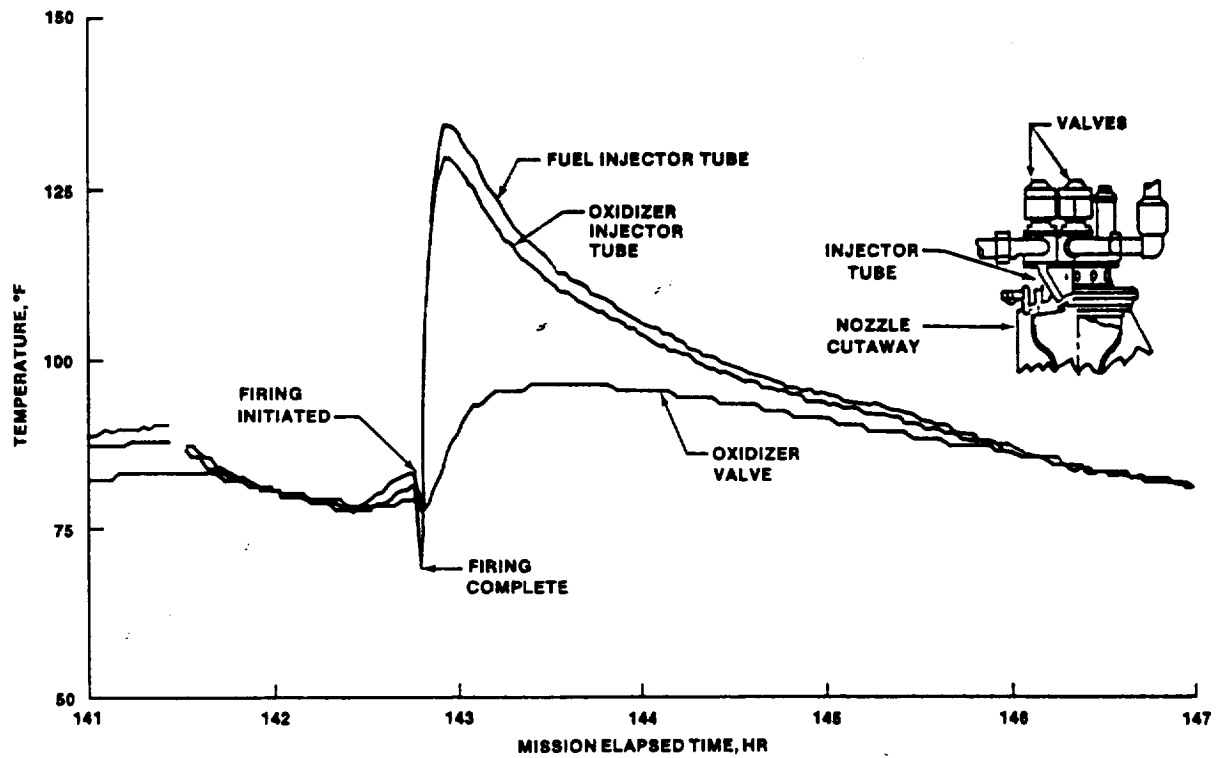

FIGURE 23.- STS-4 FORWARD PRIMARY RCS ENGINE TEMPERATURE RESPONSE TO 30-SECOND FIRING.

CONCLUSIONS

The definition of comprehensive thermal test requirements and integration of these requirements with basic mission objectives, operational and crew activities, payloads, and other systems test requirements led to the successful implementation and completion of the OFT thermal flight test program. The approach of initially testing in benign environments to minimize risk and gain confidence in the design before thermally stressing the vehicle proved to be sound. The approach also provided a basis of known performance for mission planning in critical areas such as payload bay door closure and preentry thermal conditioning.

The success of the test program was due largely to the dedication of mission planning, program requirements, and engineering personnel working as a team to integrate the various objectives and requirements into cohesive and practical crew activities and time lines for each test flight. Adequate data were obtained to support verification of the Orbiter TCS design. Results of preliminary analyses indicate that the TCS design will meet or exceed the vehicle specification requirements.