

## Recent Advances in Design of Low Cost Film Concentrator and Low Pressure Free Piston Stirling Engines for Solar Power

Jürgen + Hans Kleinwächter	William Beale
BOMIN-SOLAR GmbH	Sunpower Inc.
Lörrach, West-Germany	Athens, Ohio, USA

The rapid development of free piston stirling engine technology in combination with low weight pneumatically formed plastic film concentrators makes possible solar thermal power plants with a combination of high performance and low cost. Recent improvements in the system allow the production of 10 kW of net electric power to the grid from a dish of approximately 7.3 meter diameter without the need for a cover dome. This system is believed to be practical and cost effective in Sahara environments.

The main power unit is a single cylinder low pressure 50 Hz free piston engine with hydrodynamic gas bearings of a simple and durable design. This machine is capable of high efficiency and long life without severe constraints on dimensional accuracy of its moving parts. Lower power versions of this machine have been successfully tested and have met their design performance goals.

The alternator driven by the engine has high power density and efficiency at least equal to that of rotary alternators presently available. If desirable, the alternator can be designed to deliver three phase power. Since reciprocating mass of the alternator is low, the operating frequency can be achieved without recourse to gas springing other than that available from the working gas, thus permitting a very simple and durable engine-alternator combination without stringent demands of axial alignment or other mechanical perfections.

It is believed that the combination of simple, low cost concentrator with a single cylinder, low pressure free piston engine and an efficient and durable alternator forms a leading combination for the production of electric power from solar energy.

## System Conception

Parabolic dish concentrators in combination with stirling engines represent the most promising thermodynamic solar-electricity system.

Beside its potential to deliver efficiencies from sunlight to electricity of over 25 %, there exist also good possibilities to build cost efficient, modular solar power stations.

In general high performing technical systems are more complex and thus expensive as systems dealing with low efficiencies and non sophisticated technology.

It was the main line of BOMIN-SOLAR's and Sunpower's thinking to overcome this law by developing a power station combining a low weight pneumatically formed plastic film concentrator with a single cylinder free piston stirling engine.

Both components are of extremely simple conception and once fully developed will be inexpensive in mass production. However, the development of simple high efficient inexpensive film concentrators and free piston stirling engines requires very complex studies in the field of materials, analytic understanding and structural design. Only the result looks simple, whereas the way to it is very complicated. That's the difference between simple and primitive technology.

The first part of the paper describes the status and recent advances of the plastic film concentrator, the second part the similar situation for the free piston stirling engine.

### 1. Plastic Film Concentrators

As we described during the last parabolic dish meetings our company is developing since 1972 parabolic dish mirrors by stretching plane, metalized plastic membranes over hollow, drum shaped structures. By forming pneumatically the membrane with slight over or underpressures (Fig. 1, Fig. 2) we got concentration ratios over 1000 (Fig. 3) and thus an enough good optical performance to produce with good efficiencies temperatures over 700°C needed for stirling operations (Fig. 4). Beside the pneumatically formation of dish type concentrators we also investigated the possibilities to deform the membrane by electric, magnetic or photonic means (Fig. 5).

We then studied the possibility to build excentric parabolic dishes with non circular circumferances by utilizing the same membrane technology. The result was the Fix-Focus concentrator (fig. 6) which led to a very attractive combination with a Beale free-cylinder stirling water pump. (fig. 7)

The material problem of the membrane was solved by utilizing the fluor-polymeric material Hostaflon-ET from the Hoechst company (table 1). The chemical inertness of this plastic film is on the one hand the

the reason for most of its outstanding properties like long life time without degradation, but leads on the other hand to difficulties in metallizing and assembling the membranes. Adequate technologies were developed.

The basic economic arguments for thin film parabolic dishes are their simplicity in production and their low weight. As big dishes with thin membranes of 100  $\mu\text{m}$  thickness are sensible to wind-loads, it is consequent to protect them under transparent domes (fig. 8). The disadvantages of this combination are however the extra costs for the dome, the reduction of the light-flux reaching the mirror ( $\approx 10\%$ ), and the danger of burning parts of the dome cover during an accidental walk-off of the hot spot.

This situation led to recent developments and advances in our parabolic dish program.

## 2. Recent Advances

The fig 9 shows one membrane section of an elastically deformed film concentrator. The relationship between the two main radiuses of curvature  $\rho_I$  and  $\rho_{II}$ , the two corresponding tensions  $\sigma_I$  and  $\sigma_{II}$ , the membrane thickness  $S$  and the normal tension  $P$  is given by equation 1.

$$\boxed{\frac{\sigma_I}{\rho_I} + \frac{\sigma_{II}}{\rho_{II}} = \frac{P}{S}} \quad \underline{\text{equation 1}}$$

For a parabolic dish with the focal length and the equation

$$\boxed{z = \frac{x^2}{4f}} \quad \underline{\text{equation 2}}$$

The ratio of the main radiuses of curvature is given by

$$\begin{aligned} \rho_I &= 2f \left[ 1 + \left( \frac{x}{2f} \right)^2 \right]^{1/2} \\ \rho_{II} &= 2f \left[ 1 + \left( \frac{x}{2f} \right)^2 \right]^{3/2} \end{aligned} \quad \longrightarrow \quad \boxed{\frac{\rho_{II}}{\rho_I} = 1 + \left( \frac{x}{2f} \right)^2} \quad \underline{\text{equation 3}}$$

Only in the summit of the curvature ( $x \ll f$ ) the ratio of  $\frac{\rho_{II}}{\rho_I} \rightarrow 1$  that means in this region the membrane shape is spherical, whereas in the outer regions  $\frac{\rho_{II}}{\rho_I} > 1$  the membrane becomes more and more cylindrical.

For this reason, in order to get a perfect parabolic shape, the ratio between  $\frac{\sigma_I}{\sigma_{II}}$  must be depending from  $x$  so that

$$\frac{P}{S} = \frac{\sigma_I}{\rho_I} + \frac{\sigma_{II}}{\rho_{II}}$$

equation 4

which leads to the necessity of an anisotropic prestretching of the membrane.

We developed the technology of anisotropic prestretching of membranes as well for the general case of excentric parabolic dishes (fig. 10) as for the mostly required case of rotational parabolic dishes (fig.11).

It is shown, that the membrane is divided in several sectors whose lining is formed by clamping profiles (fig. 12) with multiple function.

-1) They permit the anisotropic prestretching of the film membrane as indicated in fig 11.

-2) As indicated in fig 13 the junction line between two film' membranes is in general disturbed because pasted seams or weld seams represent unhomogenities. Fig 14 shows that the clamping profiles compensate this disturbance and are individually adjustable by regulating screws.

-3) As a membrane parabolic dish concentration is functionally represented by the equation

$$\left(\frac{w_r}{w_0}\right)^2 = -2 \frac{0.9}{a^2} r - 4 \frac{0.1}{2^2} r^3$$

equation 5

and thus in its peripheric regions steeper than a real parabola, this divergency is also corrected by the clamping profiles.

-4) The division of the membrane into several smaller sectors by said clamping profiles stabilizes the mirror against wind forces and prevent flopping, especially when during non-operation times the membrane forming pneumatic pressure is interrupted. Consequently a profile reinforced plastic thin film concentrator of big dimensions can be free standing without protection dome.

As a first prototype we realized a 3 m diameter dish with profile reinforcement of the two parallel welded seams (fig. 15). Besides the wind stabilizing effect the result was a much higher concentration ratio as for the free membrane case.

The second prototype with a sectoral profile reinforcement has a diameter of 3,5 m (fig. 16) and has the capacity to produce concentration ratios > 5000.

Basing on these experimental results we are now planning to combine

a sectorial profile reinforced parabolic dish with a 10 kW<sub>el</sub> free piston stirling generator as described in chapter 2.

The technical datas of this stirling dish concentrator are:

Insolation:	900 W/m <sup>2</sup>
Reflectivity: (Hostaflon-ET with silver back layer)	0,9
Cavity efficiency:	0,9
Stirling overall efficiency: (Heat to electric)	0,38
Total efficiency:	27,3 %
Diameter of mirror:	7,2 m
Concentration ratio:	1500
Diameter of hot spot:	18,6 cm
Tracking mecanism:	astronomical mounting

The expected ex factory costs are given in the following table

component price in U.S.Dollars	number of mirrors, power in MW	100 mirrors 1 MW	1000 mirrors 10 MW	10000 mirrors 100 MW
10 KW free piston stirling generator		1900	1400	1000
7,2 m mirror structure		5000	4000	3000
100 m <sup>2</sup> plastic film and reinforcement structure		5000	3000	2000
Astronomic mounting		4000	3000	2500
Foundings		5000	3000	2000
<u>Costs per installed KW<sub>el</sub> peak</u>		2.090 \$	1.440 \$	1.050 \$

Rough economical analyses basing on a yearly production of 10000 units (100 MW<sub>el</sub>) located at a site with 2500 KWh/m<sup>2</sup>year insolation

Yearly average system efficiency =	25 %
Life time =	20 years
Price per m <sup>2</sup> of system =	258 \$.
Rate of interest =	10 %
Yearly costs (y.c.) per m <sup>2</sup> of system =	25,8 \$
Selling price of KWh <sub>el</sub> to customer =	10 cents
Yearly production of electric energy per m <sup>2</sup> of system (y.p.)	625 KWh <sub>el</sub> ≙ 62,5 \$

Conclusion: y.p. > y.c. = economical

Fig.1

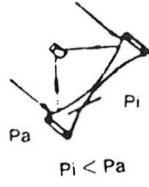

**Underpressure mirror**

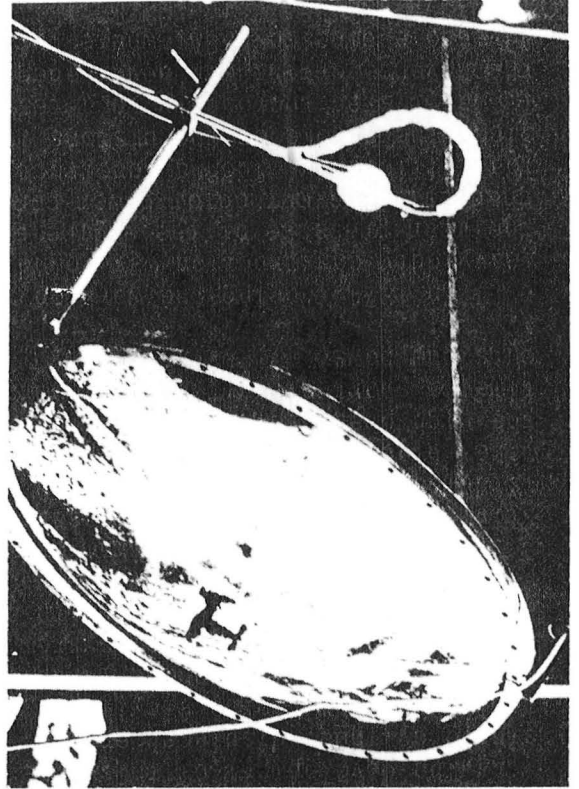
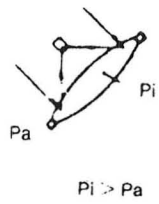
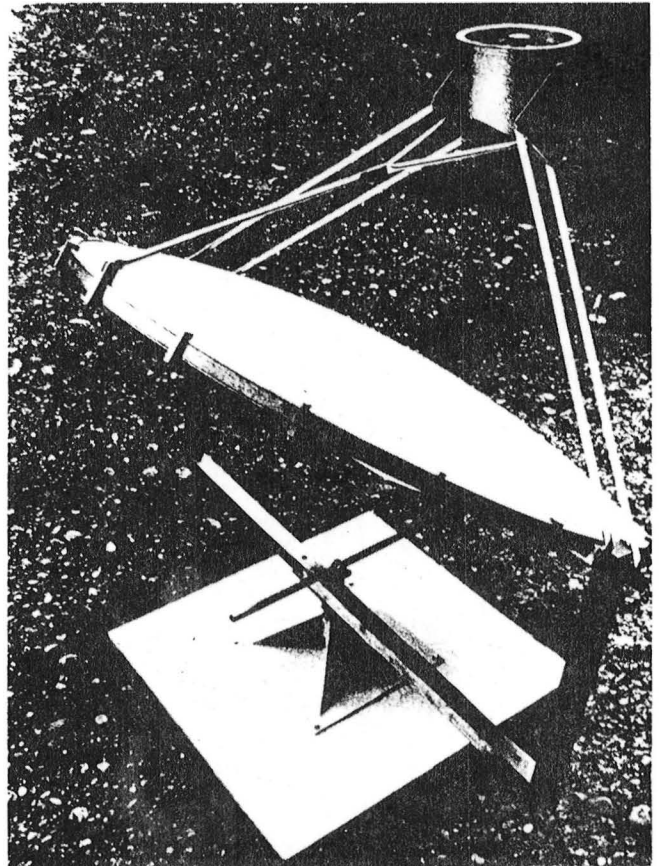

Fig.2



**Overpressure mirror**



C geometric

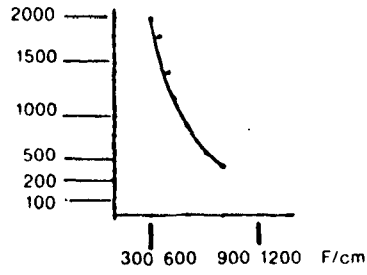

Fig 3 Concentration ratio of a 3 m underpressure mirror as a function of the focal length  $F$ .

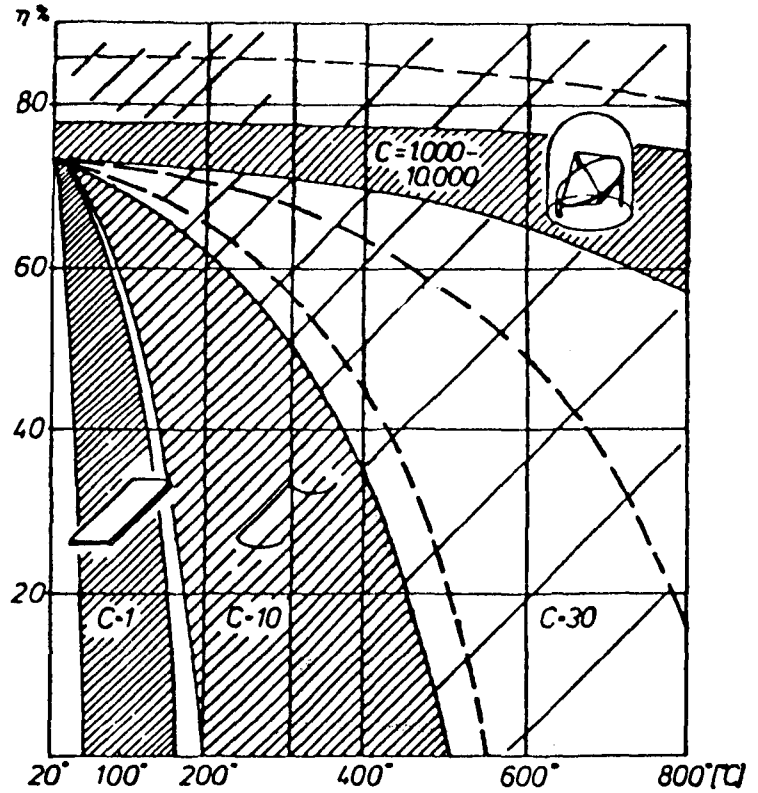
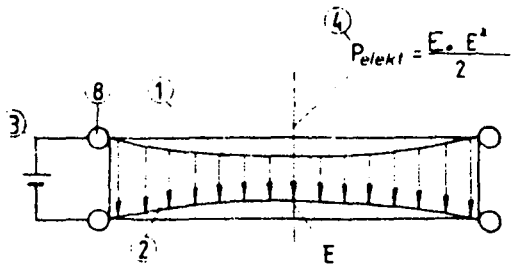
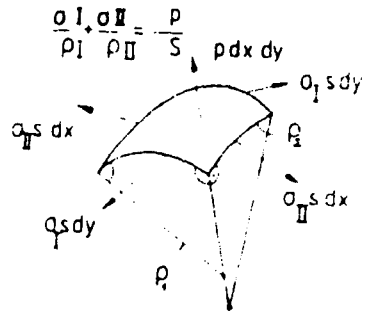

Fig 4 Efficiencies of transformation from solar radiant energy into thermal energy as a function of the temperature and of the optical concentration





electric field deformation



membran section

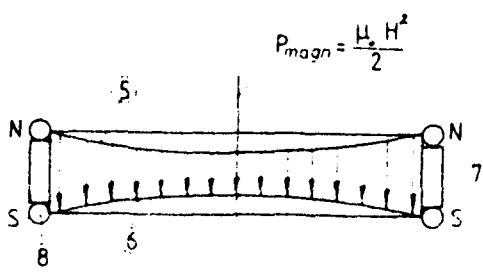

magnetic field deformation

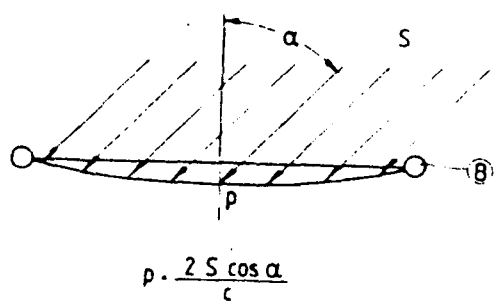

photonic deformation

Fig. 5 Different possibilities to deform film membranes

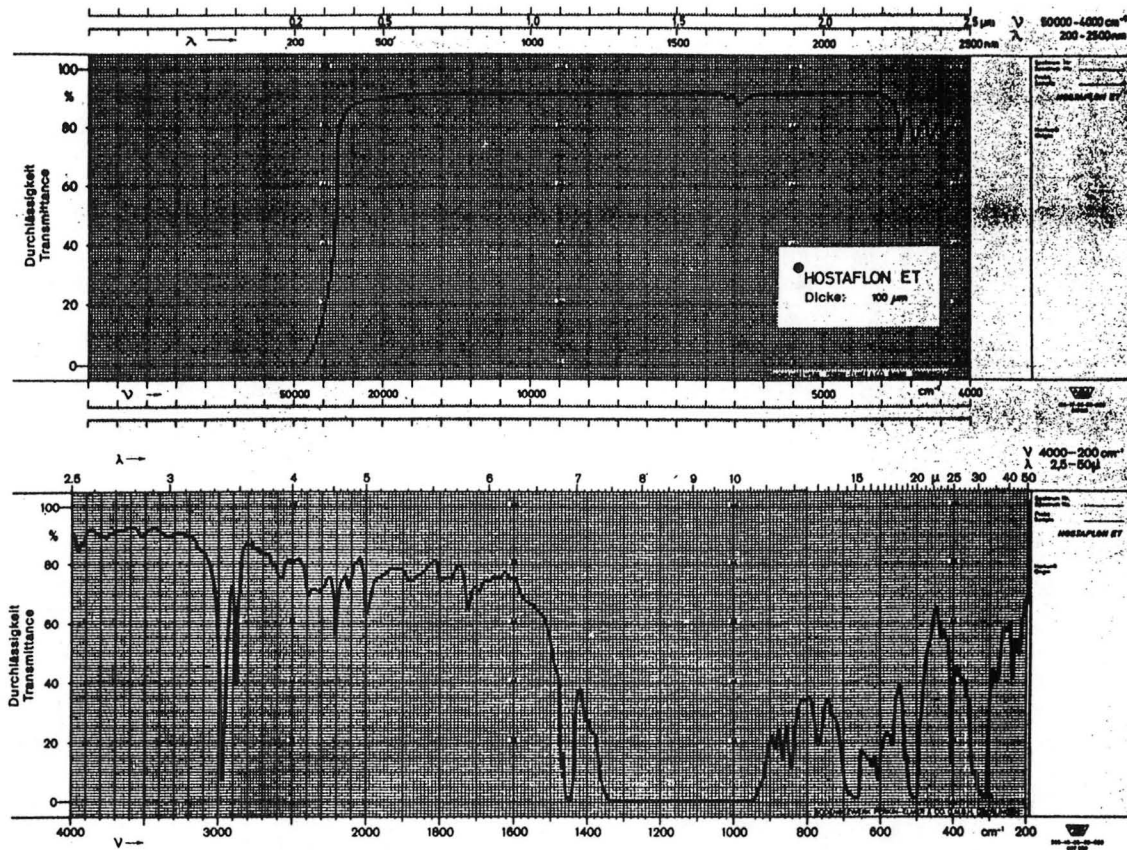

<u>Thermal operation</u>	- -	190° - + 150° C
<u>Melting range</u>	-	265° - 278° C
<u>Transparency (100 μm foil)</u>	-	95 %, 10 % of diffuse light
Tensile strength	(at 23° C)	53 N/mm <sup>2</sup>
Yield stress	"	30 N/mm <sup>2</sup>
Breaking extension	"	300 %
Tear strength	"	440 N/mm <sup>2</sup>

The foil is weldable and metallizable. Therefore it is used not only for the dome-covering but also for the foil mirror.

Table 1 Properties of Hostafilon-ET film

Fix-Focus-Solar-Stirling  
Water-pump

-7-

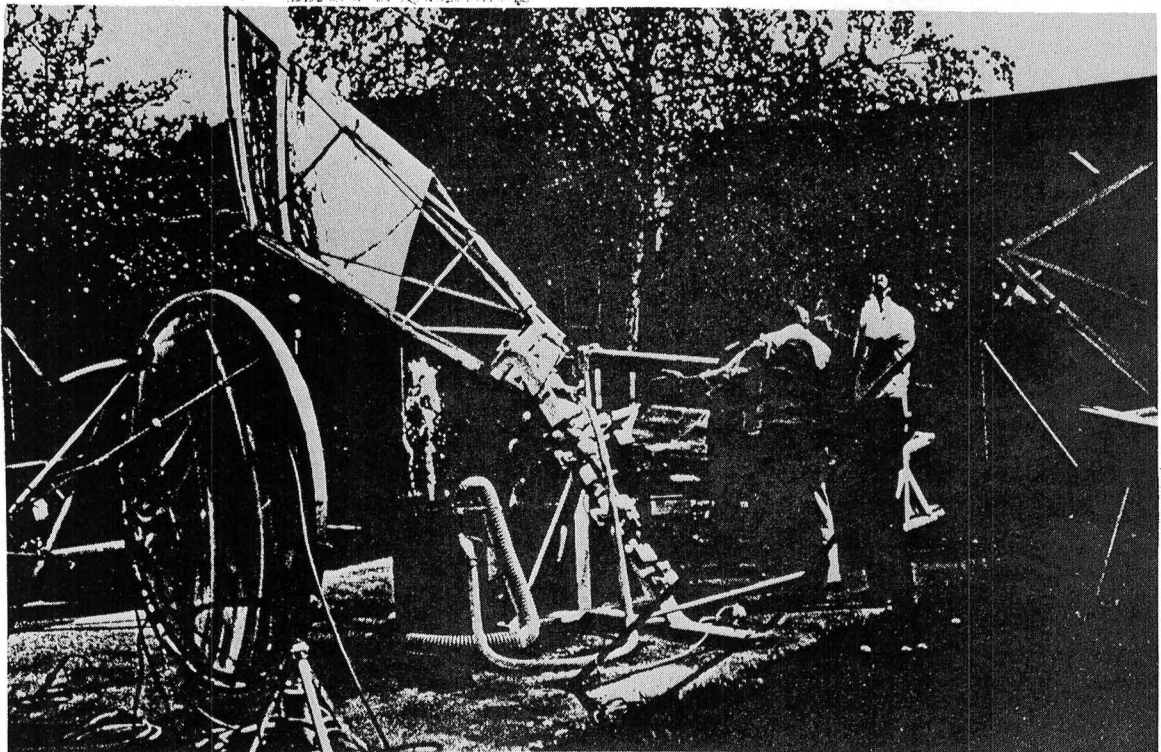
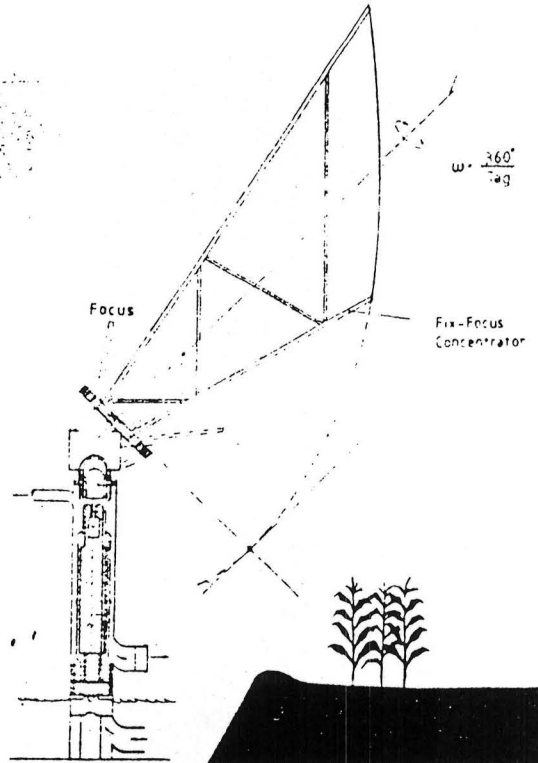
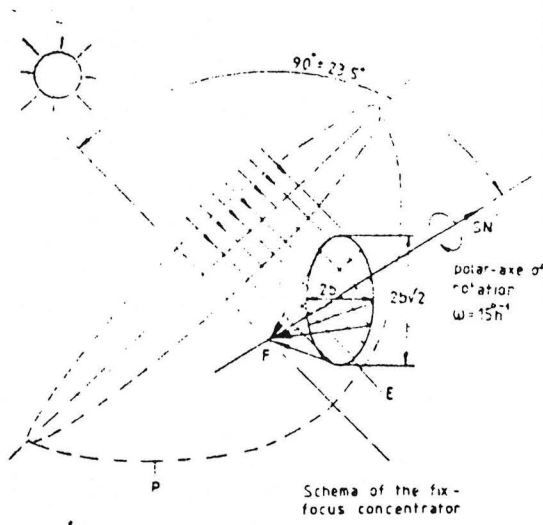

Fig. 6

and

Fig. 7

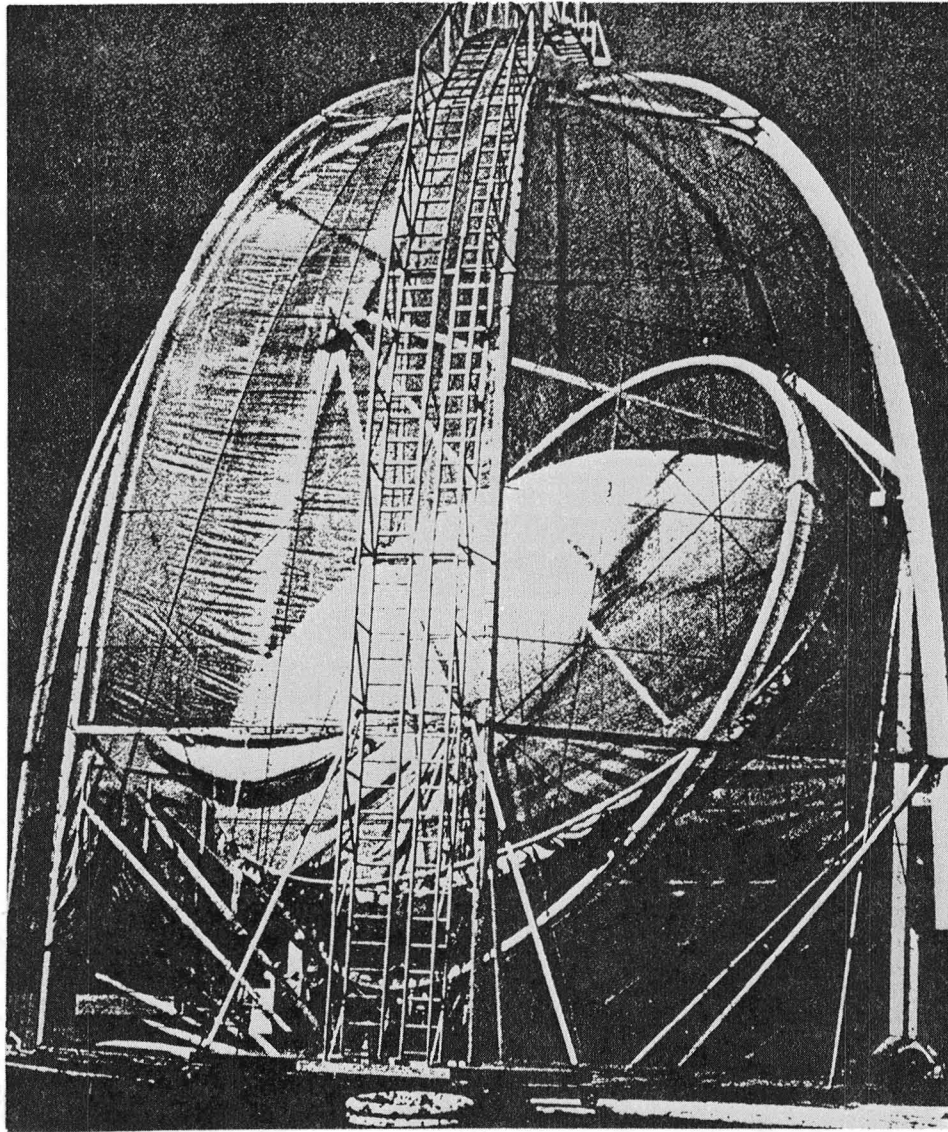

Fig. 8 10 m diameter film dish under dome

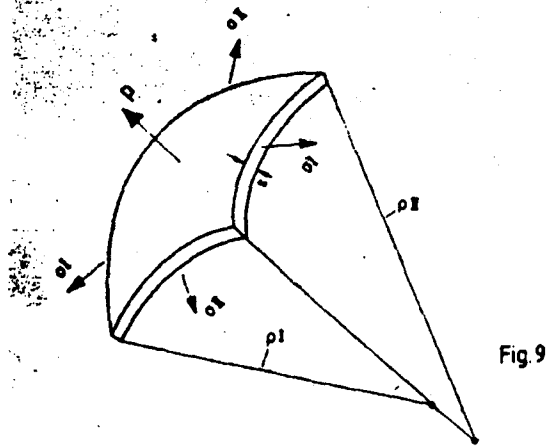
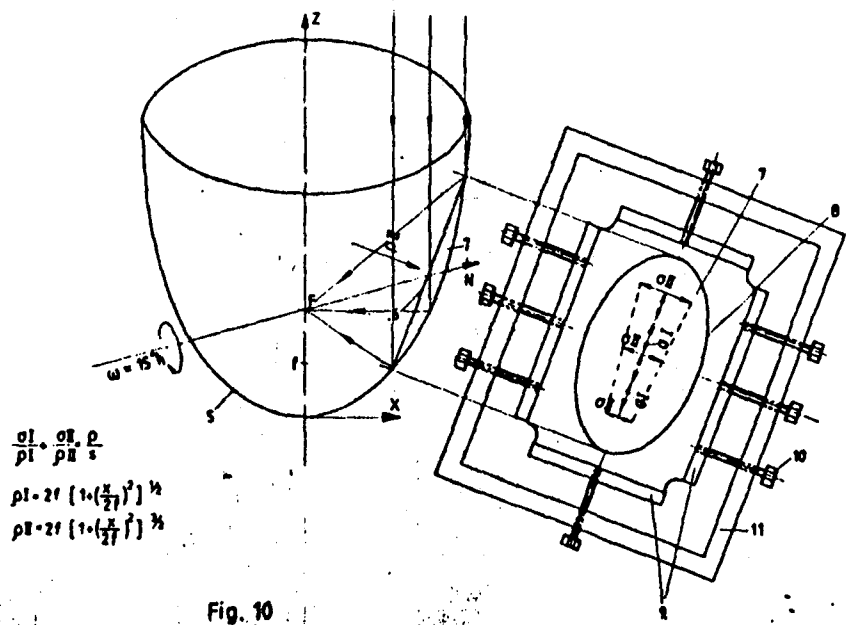

Fig. 9 Membrane section



$$\frac{\rho I}{\rho II} = \frac{\rho I}{\rho II} \frac{r}{r}$$

$$\rho I = 2r \left\{ 1 + \left( \frac{r}{2r} \right)^2 \right\}^{\frac{1}{2}}$$

$$\rho II = 2r \left\{ 1 + \left( \frac{r}{2r} \right)^2 \right\}^{\frac{1}{2}}$$

Fig. 10 Prestretching of excentric film dish

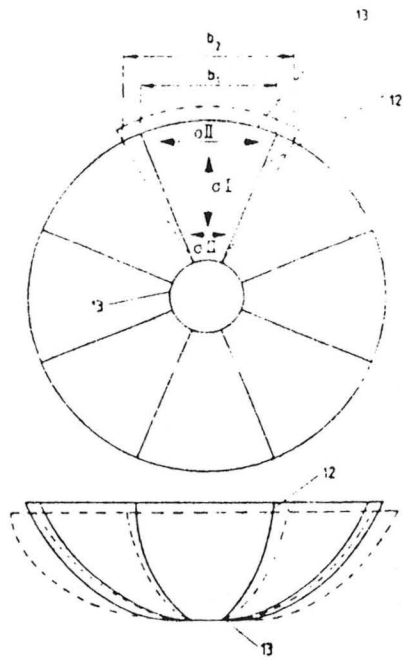

Fig. 11

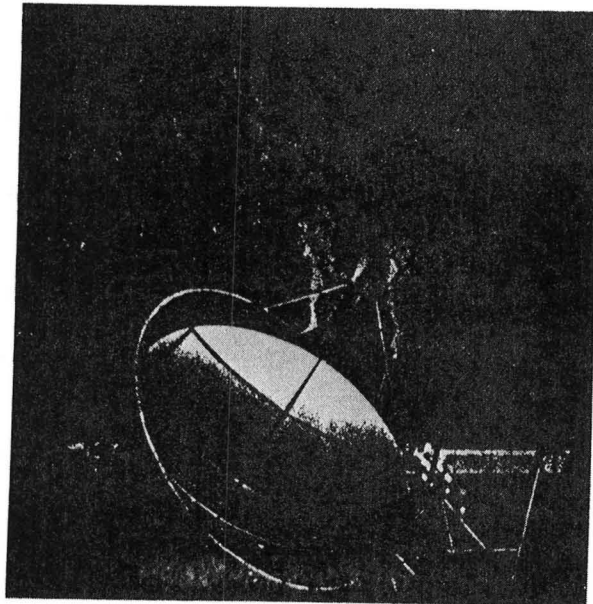
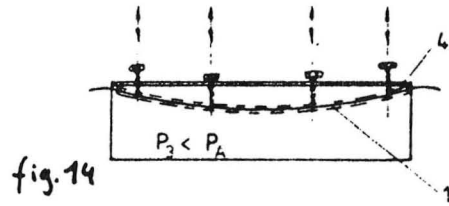
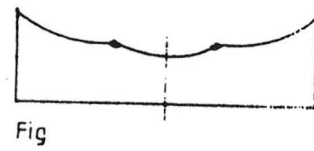
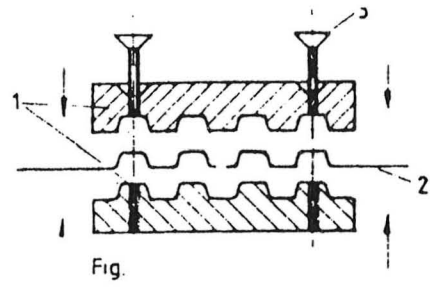

Fig. 15 3 m film dish with reinforcement of the parallel welded seams

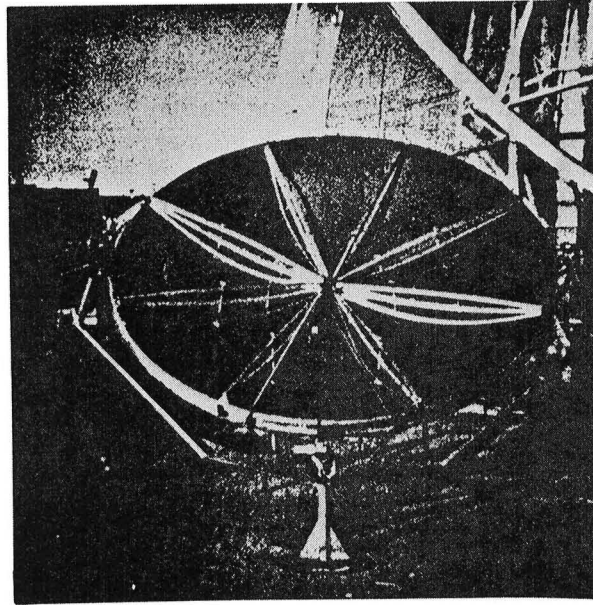

Fig. 16 3,5 m dish with sectorial reinforcement

#### References

Hencky "Über den Spannungszustand in kreisrunden Platten mit ver-  
schwindender Biegesteifigkeit" Zeitschrift für mathematische  
Physik, Vol. 63, 1915

Beale et al. IECEC meeting 1983

- a) The development of a 1 KW electrical output free  
piston stirling engine alternator unit
- b ) The free piston stirling engine - 20 years  
of development

Kleinwächster H.+J. "Solar driven stirling engines water pumping,  
cooling, electrification in rural areas and for  
future space stations" Proceedings comples meeting  
October 1983, Freiburg

## DESCRIPTION OF ENGINE-ALTERNATOR

The free piston engine-alternator described here is a first attempt at a design above 3kW. As such it represents only the beginning of what can be expected of machines of this type. But never the less, its promise is evident from its simplicity and projected performance. The performance given in the table below is derived from computer simulations using the Sunpower SYM-4 code, which has demonstrated its predictive capability within about 10% in power and efficiency over a very wide range of designs from 100 watt linear alternators to very low temperature ratio heat pumps.

Table of Performance Characteristics of 10kW Solar  
FPSE As Predicted by Computer Simulation

Power Output	10kW (e)
Engine Thermal Efficiency (Shaft Power/Heat to Head)	40%+ @ 700°C Heat Temperature
Frequency (Hz.)	50
Working Fluid	Helium at 20 Bar
Cooling	Water @ 50°C
Engine-Alternator Dimensions	
Weight	150kg
Diameter	440mm
Length	830mm

ENGINE - The engine is a conventional free piston engine except in its pressure, which is relatively very low in comparison to its predecessors, large diameter, short stroke, thin wall and high frequency. (Figure 1). The advantages of such design include large heater head surfaces appropriate for the external heat transfer rates available, large piston diameter in correct ratio to the alternator size needed to match the power and high working space spring rates necessary to oscillate the piston and magnets at the desired frequency.

The moving parts of the engine are aligned precisely on a central rod, which also serves as a bearing surface for the displacer and its gas spring and a location for the alternator stator.

### HEATER-ABSORBER

The heater-absorber designed for the first prototype incorporated a flat surface exposed to solar radiation with integral involute gas passages between the regenerator hot end and a central connection to the expansion space. Other arrangements can readily be fitted-tubes, inverted cup quartz windows, or many others. Further work is in progress to locate the heater head design with the greatest overall performance.

ALTERNATOR - The alternator is of rectangular layout, with the stator winding normal to the engine axis. This arrangement was the lightest for its power which could be found, and in addition, was very easy to make with conventional laminations.



The moving magnets are directly connected to the piston of the engine, and represent the minimum reciprocating mass possible for such an alternator, an important consideration, since the reciprocating mass determines the necessary spring rate, which in turn reflects on the thermodynamics of the working cycle and the system efficiency, as well as the mechanical complexity of the machine.

In the configuration used for the first prototype, the magnet bearing members slide on flat surfaces with contact, and a solid lubricant is used to minimize friction and wear. In designs requiring life above 10,000 hrs., it becomes desirable to use gas film lubrication, which on such flat surfaces with very light loads, is easily provided.

Alternative designs include those which are axisymmetric, with the alternator winding axis co-linear with the engine axis. This arrangement permits the use of hydrodynamic gas lubrication by way of spun piston and displacer, which method is somewhat less failure prone than the hydrostatic, with its auxiliary gas pump and very small orifices. The spinning effect is achieved by the impingement of the cooler port gas flow on small turbine blades milled into the facing surfaces of the piston and displacer. A trivial amount of cycle power is diverted to effect the spinning action.

#### COOLING

The necessary cooling can be done by a rear mounted cylindrical heat exchanger and axial fan, with the coolant, which may be the same fluid as the working gas, moving from the engine internal cooler to the external heat exchanger either by way of a circulating pump, or in the case of a boiling coolant, by vaporization and condensation with gravity return.

If the cycle rejected heat is to be used for some other purpose, then the necessary conduit must be arranged from the ground to the engine.

#### ADVANTAGES OF THE FPSE OVER CRANK DRIVE MACHINES FOR SOLAR APPLICATIONS

The free piston promises at least the following advantages over the crank type Stirling engine for Solar applications:

Since it is a single cylinder machine with essentially one working space, there is no possibility of flow maldistribution as can happen between the four working spaces of the double acting four cylinder crank type engine. Such flow unbalances can cause one of the heater tube sections to become hotter than the others and force a lower average working temperature in the four cylinder machine.

The free piston engine has only two essential moving parts, and is as a result much simpler and easier to make than the crank machine. Not only are the parts fewer, but they are also simpler, since the clearances on the sliding surfaces are quite generous, on the order of 50 to 70 microns.

There is no need for any liquid lubricant, with its attendant requirement for total exclusion from the working spaces.

There is no high pressure seal, and the seals that are used are not required to have close fits, since a small amount of blowby is acceptable, for the reason that it does not represent a loss of working fluid, nor does it carry with it any liquid contaminant. The only consequence of seal leak in the free piston machine is a slight degradation of performance.

The linear alternator of the free piston machine can be made to be very efficient and at the same time quite light for its power. Over 90 percent efficiency and a specific weight of about 6kg/kW for the alternator are readily and economically achievable.

The response of the FPSE to varying thermal input is such that minimal control action is necessary. In the case of a direct grid connection, all that is required in the way of a control circuit is a disconnect which acts when alternator voltage is below line voltage.

It is not necessary to change pressure to match the engine to varying heat input, since the internal dynamics are such that temperature rise results in a very rapid rise in power capability, thus limiting temperature and efficiency variation to a low range as power varies between half and full power.

Since there is little mechanical friction in the FPSE, it will run to a low temperature difference. Usually about 100 degrees difference between source and sink suffices to keep it oscillating. This characteristic minimizes the need for restart during periods of varying solar input.

#### SUMMARY

The free piston Stirling-linear alternator has been shown to be scalable to power levels of tens of kilowatts in a form which is simple, efficient, long lived and relatively inexpensive. It avoids entirely the vexing problem of high pressure shaft seals, and its control requirements are not severe nor do they represent a significant threat to durability. Linear alternators have demonstrated high efficiency and moderate weight, and are capable of delivering 3 phase power from single machines without great increases of cost or complexity. There remains no apparent impediments to the commercial exploitation of the free piston engine for solar electric power generation.

## ENGINE - ALTERNATOR LAYOUT

