

5.12A CHUNG-LI, TAIWAN DUAL MODE
(DOPPLER AND SPACED ANTENNA) VHF RADAR:
PRELIMINARY SPECIFICATIONS

J. Brosnahan*, J. Chao**, and J. Rottger***

*Tycho Technology, Inc., P. O. Box 1716, Boulder, CO 80306

**Dept. of Atmospheric Physics, National Central University, Chung-Li,
Taiwan 320, Republic of China

***EISCAT Scientific Association, Box 705, S-981, 27 Kiruna, Sweden

In February 1982 a workshop on VHF coherent radar was held in Chung-Li, Taiwan. The workshop was sponsored by the National Science Council of the Republic of China and the National Central University. A VHF radar design with unique capabilities is the result of this conference.

A major unresolved question in the field of atmospheric research using VHF radar techniques is the relative merit of the two most widely used systems. These systems are the Doppler method as described by GAGE and BALSLEY (1978) at the Poker Flat, Alaska MST radar, and the spaced antenna method as described by ROTTGER (1981) at the SOUSY-VHF radar in Germany.

It has been suggested that one radar of each type be operated side by side for a direct comparison of the two techniques. This duplication of effort is not cost effective. The major components of both systems are identical, and one radar could be operated in both modes by proper design of a suitable antenna system and by proper data analysis. The Chung-Li radar will be able to switch between modes on a time scale of seconds and is the first VHF radar to be able to directly compare the Doppler data with spaced antenna data. The system will have performance comparable with the present SOUSY spaced antenna system and will provide mesospheric data in addition to stratospheric and tropospheric data. Table 1 lists the major specifications of the Chung-Li radar.

Figure 1 is the block diagram of the system. The radar is a monostatic system using commercially available components to minimize development time and cost. The minicomputer will initially be utilized only to write integrated data to tape and provide a minimum of real-time displays. All data analysis will be done off line on the National Central University's CDC Cyber computer. In designing a VHF radar facility the antenna system provides the greatest opportunity to maximize the system performance cost ratio. Because of the requirement to operate the Chung-Li radar in both the Doppler and spaced antenna modes, Yagi antenna elements were chosen to provide symmetry in both horizontal axes. Three separate subarrays are required for the spaced antenna system of analysis. Subarrays of 64 elements each provide a symmetrical array of 8 x 8 elements and a number of feed points that can be easily matched with equal power distribution utilizing a simple power divider scheme. The Yagi elements are oriented at 45 degrees to the directions of lobe steering (Figure 2) to provide identical patterns when the beam is steered in azimuth in 90 degree steps.

By choosing a delay line system requiring only 0, 90, 180, and 270 degree delays, a very simple beam-steering system can be implemented, as shown in Figure 3. Once the delay line system is determined, the angle of the beam from the zenith is dependent on array element spacing. This spacing is chosen to simultaneously provide a main beam at a zenith angle of between 10 and 20 degrees, provide an array null at the zenith, and provide adequate sidelobe suppression, especially at the horizon. The beam angle is equal to the arc sine of 90 degrees (the basic delay line increment) divided by the element

Table 1. Specifications

SITE: National Central University, Chung-Li, Taiwan, R.O.C.
 LATITUDE: 25 degrees north longitude: 121 degrees east
 TYPE: Dual mode (Doppler-Spaced Antenna)
 FREQUENCY: 52 Megahertz
 ANTENNA: Three arrays of 64 Yagis each
 AREA: Three 2900 square meter arrays
 TRANSMITTER: 180 kW
 MAXIMUM RESOLUTION: 150 Meters
 ESTIMATED COMPLETION DATE: Late 1983

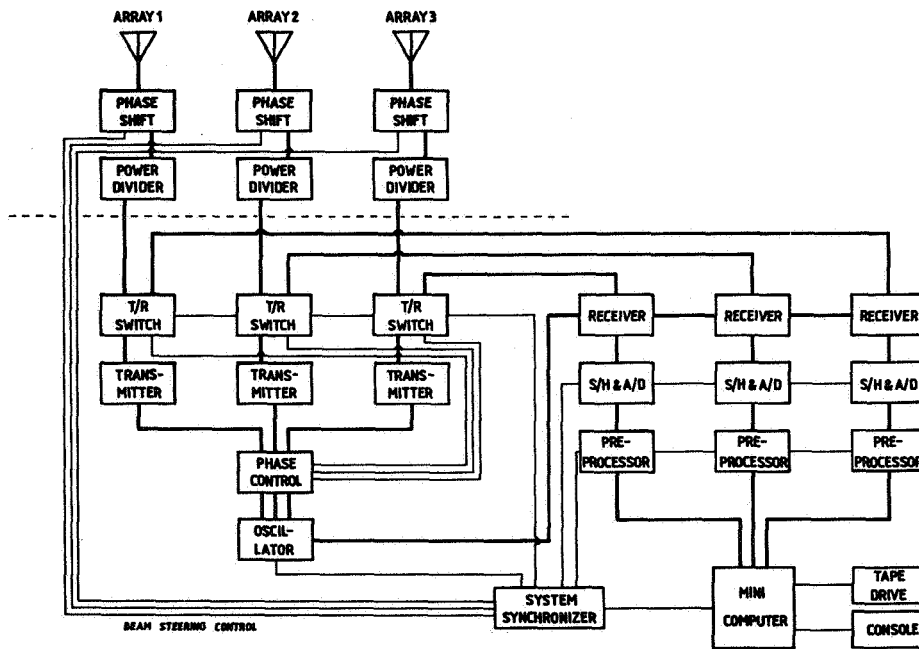

Figure 1. Chung-Li radar block diagram.

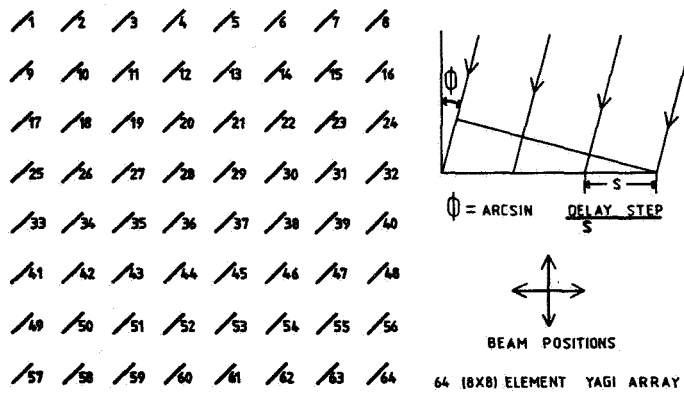

Figure 2. Yagi array orientation.

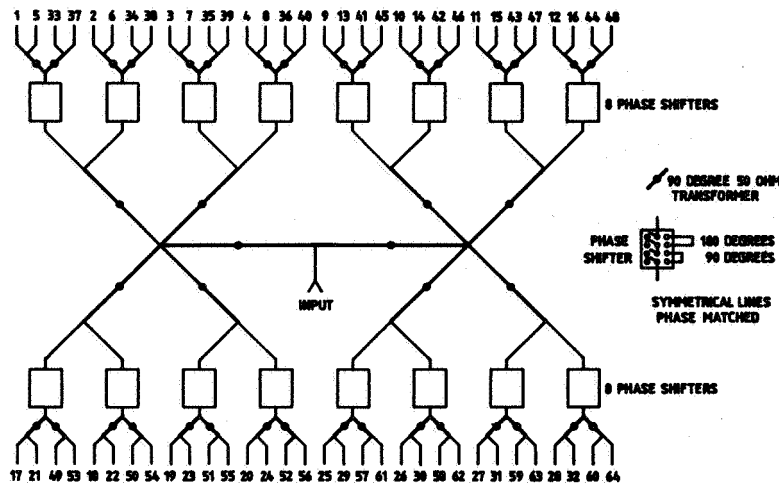

Figure 3. Power divider and beam steering phase delay.

spacing in degrees. A spacing of between 0.75 and 1.5 wavelengths provides a main lobe of between 19.5 degrees and 9.6 degrees, respectively. Element spacing in the 1 to 1.25 wavelength look the most promising, and computer modeling is presently being done to optimize the system. Table 2 shows the element phasing for the seven available beams.

Once the optimum spacing is selected the individual Yagi design is determined to best fill the aperture while having a pattern consistent with the overall array pattern. Four- or five-element Yagis are appropriate. The 45 degree orientation of the Yagi arrays tends to help reduce the mutual coupling between elements of the array. The beam-steering system also allows alternate Yagis to be fed out of phase to provide two orthogonal twin lobe patterns

Table 2. Beam steering element phasing

ELEMENT	Delay Line Phase Lag in Degrees					NORTH SOUTH DUAL	EAST WEST DUAL
	VERT	NORTH	EAST	SOUTH	WEST		
1, 5,33,37	0	270	0	0	270	0	0
2, 6,34,38	0	270	90	0	180	0	180
3, 7,35,39	0	270	180	0	90	0	0
4, 8,36,40	0	270	270	0	0	0	180
9,13,41,45	0	180	0	90	270	180	0
10,14,42,46	0	180	90	90	180	180	180
11,15,43,47	0	180	180	90	90	180	0
12,16,44,48	0	180	270	90	0	180	180
17,21,49,53	0	90	0	180	270	0	0
18,22,50,54	0	90	90	180	180	0	180
19,23,51,55	0	90	180	180	90	0	0
20,24,52,56	0	90	270	180	0	0	180
25,29,57,61	0	0	0	270	270	180	0
26,30,58,62	0	0	90	270	180	180	180
27,31,59,63	0	0	180	270	90	180	0
28,32,60,64	0	0	270	270	0	180	180

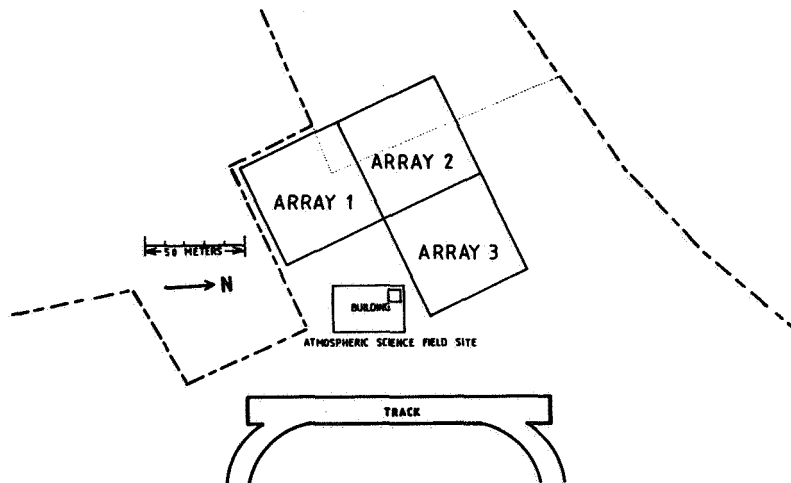

Figure 4. Chung-Li radar site.

providing a null at the zenith. These twin lobe patterns provide Doppler data with both positive and negative components, the difference between the two sidebands providing data on momentum transport [VINCENT, 1982].

The spaced antenna mode prefers 120 degree array symmetry and the Doppler mode prefers 90 degree symmetry. Final array configuration will be determined by computer modeling. Figure 4 shows one possible array orientation for the Chung-Li site which dictates a three-element array. Of course a total of four arrays could be utilized to provide more gain and symmetry in all axes if the site is available. The three arrays can be operated independently or together in all combinations of the seven beam patterns (vertical, off zenith in four azimuths, and two dual-beam patterns with a null at the zenith). This provides maximum flexibility for a relatively simple antenna system.

System installation will be completed in late 1983, and will provide a new and unique capability to make measurements in the mesosphere, stratosphere, and troposphere. Of special interest is the capability to provide excellent data during the many typhoons that come near or hit Taiwan.

REFERENCES

- Balsley, B. B. and K. S. Gage (1980), The MST radar technique: Potential for middle atmospheric studies, Pure and Appl. Geophys., **118**, 452-493.
- Gage, K. S. and B. B. Balsley (1978), Doppler radar probing of the clear atmosphere, Bull. Amer. Meteorol. Soc., **59**, 1074-1093.
- Rottger, J. (1981), Investigations of lower and middle atmospheric dynamics with spaced antenna drifts radars, J. Atmos. Terr. Phys., **43**, 277-292.
- Vincent, R. A. (1982), The use of multibeam Doppler radars to study gravity wave momentum fluxes, presented at the Workshop on Equatorial Middle Atmosphere Measurements and Middle Atmosphere Radars, Estes Park, CO., 10-12 May 1982.