

5.6A COMPLEMENTARY CODE AND DIGITAL FILTERING FOR DETECTION OF WEAK VHF RADAR SIGNALS FROM THE MESOSPHERE

G. Schmidt, R. Ruster and P. Czechowsky

Max-Planck-Institut fur Aeronomie
D-3411 Katlenburg-Lindau 3, Germany

The following is an excerpt from this paper which was published in IEEE Transactions on Geoscience Electronics, Vol. GE-17, No. 4, 1979, 154-161.

THE SOUSY RADAR FACILITY

The SOUSY-VHF-Radar operates at a frequency of 53.5 MHz in a valley in the Harz mountains, Germany, 90km from Hanover. Figure 1 presents a block diagram of the radar facility with the main system parameters. The radar controller, which is programmed by a 16-bit computer, is the central unit. It holds 1024 program steps in core and controls, via 8 channels, the whole radar system: in particular the master oscillator, the transmitter, the transmit-receive-switch, the receiver, the analog to digital converter, and the hardware adder.

The transmitter operates as a linear amplifier with a bandwidth of 2.5 MHz. The peak pulse power is 600 kW and the duty cycle 4 percent. The pulse length can be varied from 0.8 to 100 μ s. The maximum height resolution is somewhat larger than 120 m because the receiver bandwidth is 1 MHz. Pulse length, pulse coding, and pulse repetition frequency are easily adjustable to the requirements of the different observational programs by software instructions.

The transmitter, the receiver, and the antenna are connected to a high-speed transmit-receive switch with a recovery time of less than 5 μ s, corresponding to a minimum radar range of about 750 m. The transmitting antenna consists of a system of 196 four-element Yagis with a total gain of 31 dB and a half-power beamwidth of 5°. To reduce interference with commercial TV stations and to reduce the influence of ground clutter from the surrounding mountains, the suppression of the first side lobes of the antenna pattern is about 20 dB and the antenna response far off-axis (which corresponds to low elevation angles) is approximately 40 dB. At present the antenna beam is directed to the zenith. By means of a system of 4-bit phase shifters, which are computer controlled, the extended version of this array will be steerable continuously in any direction within a cone of 30° vertex angle centered on the vertical. The high-sensitivity receiver has a dynamic range of 70 dB and a video bandwidth of 1 MHz. The complex signals at the receiver output are digitized by an analog-to-digital converter. The maximum sample frequency is 2 megawords/s, with a word length of 10 bits, corresponding to a dynamic range of 57 dB. These digitized complex signals can be coherently added by a hardware adder with a maximum core for 1024 complex values. The adder also is used for coding techniques. Phase coding schemes are applied, in particular for investigations at mesospheric heights, in order to carry out measurements with the maximum duty cycle and the maximum height resolution. The computer takes the data from the adder to store it in magnetic tape or disc.

The central unit of the radar facility is the radar controller, which synchronously controls the whole system. The radar controller is programmed by the computer using simple Fortran IV statements. After the program has been loaded and the computer has started the radar controller, it runs automatically, stopping at the program end. In case of errors or failures occurring during the radar operation, the radar controller is shut off caused either by a

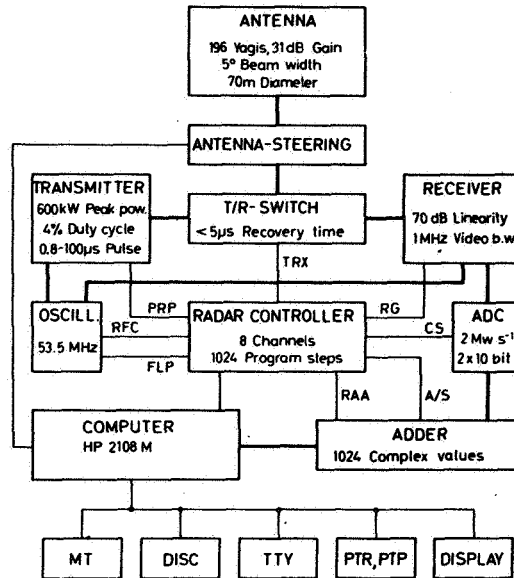

Figure 1. Block diagram of the SOUSY-VHF-Radar facility. (MT-magnetic tape, DSC-moving head disc, TTY- eletepe, PTR, PTP-paper tape read/punch, DISPLAY-storage oscilloscope.

safety circuit from the transmitter and the transmit-receive-switch or by a power failure circuit or by a parity check system in the radar controller. The response time of a shutdown in only 50 ns.

Figure 2 shows the block diagram of the radar controller. Its program, generated by the computer, is stored in two different memories and two latches. The core size of each memory is 1024 storage locations of 8-bit length. An additional bit is used for parity check. The first memory (program memory) contains the various commands and the second (rate memory) the respective time intervals for which the commands have to be carried out. These execution times are counted in clock periods, which can be chosen to be 0.5, 1, 2, or 4 μs each. Since a storage location in the rate memory consists of 8 bits, the maximum length to be stored is 255 clock periods. If, however, a program step longer than 255 clock periods is required, this command is divided into several

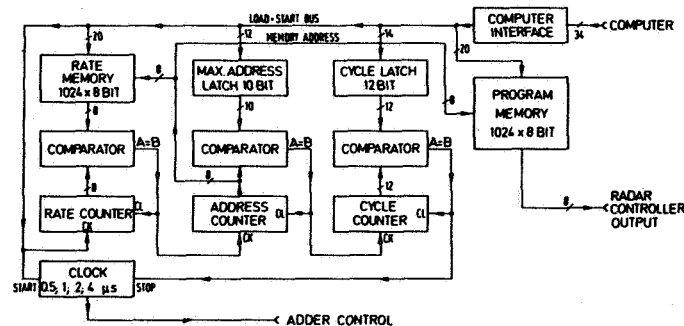

Figure 2. Block diagram of the radar controller.

sequential program steps. The two latches contains the number of repetitions of the radar cycle (cycle latch) and the maximum address for the program in the rate and program memory (maximum address latch). Three cascaded counters with comparators for reset are used as address counter, rate counter, and cycle counter.

PUBLICATIONS RELATING TO THE SOUSY RADAR

- "Forschungsschwerpunkt 'Untere Atmosphäre' - Vorläufige Studie der Arbeitsgruppe SOUSY" Interner Bericht, Max-Planck-Institut für Aeronomie, Lindau/Harz, Juni 1974.
- Czechowsky, P. (1976), Optimierung des Antennensystems für die Lindauer VHF-Radaranlage, Kleinheubacher Ber. 19, 123-126.
- Czechowsky, P., J. Klostermeyer, J. Rottger, R. Ruster and G. Schmidt (1976), Ein kontinuierlich steuerbares VHF-radarantennensystem zur Beobachtung von Scattersignalen aus der mittleren Atmosphäre, Kleinheubacher Berichte, 19, 117-122.
- Czechowsky, P., J. Klostermeyer, J. Rottger, R. Ruster, G. Schmidt and R. F. Woodman (1976), The SOUSY-VHF radar for tropo-, strato- and mesospheric sounding, Preprint Volume, 17th Conf. on Radar Meteorol., 349-353, AMS, Boston, MA.
- Ruster, R. and R. F. Woodman (1976), Radar measurements in the tropo-, strato-, and mesosphere, Preprints, 17th Conf. Radar Meteorol., Seattle, Wash., Amer. Met. Soc., 353-358.
- Rottger, J. and P. Czechowsky (1977), Clear-air turbulence and tropospheric refractivity variations observed with a new VHF-radar, Naturwissenschaften, 64, 580.
- Klostermeyer, J. and C. H. Liu (1978), Indication of gravity wave-mean flow interaction in upper atmospheric radar observations, Geophys. Res. Lett. 5, 507-510.
- Czechowsky, P., R. Ruster and G. Schmidt (1979), Variations of mesospheric structures in different seasons, Geophys. Res. Lett., 6, 459-462.
- Rottger, J. and P. Czechowsky (1978), VHF-radar echoes from the troposphere and stratosphere, Kleinheubacher Berichte, 21, 279-290.
- Rottger, J. (1978), Evidence for partial reflection of VHF radar signals from the troposphere, J. Geophys., 44, 393-394.
- Rottger, J. and P. K. Rastogi (1978), High resolution VHF radar observations of turbulence structures in the mesosphere, Report MPAE-W-00-78-30, Max-Planck-Institut für Aeronomie, Katlenburg-Lindau.
- Rottger, J. and C. H. Liu (1978), Partial reflection and scattering of VHF signals from the clear atmosphere, Geophys. Res. Lett., 5, 357-360.
- Rottger, J., J. Klostermeyer, P. Czechowsky, R. Ruster and G. Schmidt (1978), Remote sensing of the atmosphere by VHF radar experiments, Naturwissenschaften, 65, 285-296.
- Rottger, J. and R. A. Vincent (1978), VHF radar studies of tropospheric velocities and irregularities using spaced antenna techniques, Geophys. Res.

- Lett., 5, 917-920.
- Ruster, R., J. Rottger and R. F. Woodman (1978), Radar measurements of waves in the lower stratosphere. Geophys. Res. Lett. 5, 555-558.
- Ruster, R. and R. F. Woodman (1978), Digital filtering, calibration and correlation analysis of radar-echoes from the tropo- and stratosphere. Kleinheubacher Berichte 21, 239-246.
- Klostermeyer, J., R. Ruster, P. Czechowsky, J. Rottger, and G. Schmidt (1979), VHF-radar erkundet atmosphere, Umschau 79, 514-515.
- Schmidt, G., R. Ruster and P. Czechowsky (1979), Complementary code and digital filtering for detection of weak VHF radar signals from the mesosphere, IEEE Trans. Geosci. Electron., GE-17, 154-161.
- Rottger, J. (1979), VHF radar observations of a frontal passage, J. Applied Meteorol., 18, 85-91.
- Rottger, J., P. K. Rastogi and R. F. Woodman (1979), High-resolution VHF radar observations of turbulence structures in the mesosphere, Geophys. Res. Lett., 6, 617-620.
- Rottger, J. and G. Schmidt (1979), High-resolution VHF radar sounding of the troposphere and stratosphere, IEEE Trans. Geosci. Electr., GE-17, 182-189.
- Czechowsky, P. and K. Meyer (1980), Das antennensystem des SOUSY-VHF-radars internal report, MPAE-T-00-80-19, Max-Planck-Institut fur Aeronomie, 3411 Katlenburg-Lindau, FRG.
- Czechowsky, P., R. Ruster and G. Schmidt (1980), VHF-radar observations of structures and their dynamics in the stratosphere and mesosphere, Preprints, 19th Conf. Radar Meteorol., Miami, Amer. Met. Soc., 588-592.
- Klostermeyer, J. and R. Ruster (1980), Radar observation and model computation of a jet stream-generated Kelvin-Helmholtz instability, J. Geophys. Res. 85, 2841-2846.
- Rottger, J. (1980), Structure and dynamics of the stratosphere and mesosphere revealed by VHF radar investigations, J. Pure Appl. Geophys., 118, 494-527.
- Rottger, J. (1980), Reflection and scattering of VHF radar signals from atmospheric refractivity structures, Radio Sci., 15, 259-276.
- Ruster, R. and P. Czechowsky (1980), VHF radar measurements during a jet stream passage, Radio Sci. 15, 363-369.
- Ruster, R., P. Czechowsky and G. Schmidt (1980), VHF-radar measurements of dynamical processes in the stratosphere and mesosphere, Geophys. Res. Lett. 7, 999-1002.
- Vincent, R. A. and J. Rottger (1980), Spaced antenna VHF radar observations of tropospheric velocities and irregularities, Radio Sci., 15, 319-335.
- Woodman, R. F., R. P. Kugel and J. Rottger (1980), A coherent integrator-decoder preprocessor for the SOUSY-VHF-Radar, Radio Sci., 15, 233-242.
- Rottger, J. (1980), Development of refractivity structures during anticyclonic

- weather conditions, Preprint Volume, 19th Conf. on Radar Meteorol., April 15-18, Miami, FL, 593-598, AMS, Boston, MA.
- Rottger, J. and P. Czechowsky (1980), Tropospheric and stratospheric wind measurements with the spaced antenna drifts technique and the Doppler beam swinging technique using a VHF radar, Preprint Volume, 19th Conf. on Radar Meteorol., April 15-18, Miami, FL, 577-584, AMS, Boston, MA.
- Rastogi, P. K. and J. Rottger (1980), Radar detection of tropopause by coherent reflections at very high frequencies, Preprint Volume, 19th Conf. on Radar Meteorol., April 15-18, Miami, FL, 616-623, AMS, Boston, MA.
- Rottger, J. (1980), Utilization of the lower VHF band for radar experiments at the Arecibo Observatory, Technical Rep. MPAE-T-00-80-01, Max-Planck-Institut für Aeronomie, Katlenburg-Lindau.
- Klostermeyer, J. (1981), MST radars: advanced tools for gravity wave studies, Nature 292, 107-108.
- Klostermeyer, J. and R. Ruster (1981), Further study of a jet stream-generated Kelvin-Helmholtz instability, J. Geophys. Res. 86, 6631-6637.
- Rottger, J. (1981), Investigations of lower and middle atmosphere dynamics with spaced antenna drifts radars, J. Atmos. Terr. Phys., 43, 277-292.
- Rottger, J., T. Y. Kang and M. Y. Zi (1981), Mountain lee waves detected in radar wind profiles, Report MPAE-W-00-81-36, Max-Planck-Institut für Aeronomie, Katlenburg-Lindau.
- Rottger, J., P. Czechowsky and G. Schmidt (1981), First low-power VHF radar observations of tropospheric, stratospheric and mesospheric winds and turbulence at the Arecibo Observatory, J. Atmos. Terr. Phys., 43, 789-800.
- Rottger, J. (1981), The dynamics of stratospheric and mesospheric fine structure investigated with an MST VHF radar, Handbook for MAP, 2, Extended abstracts from Int. Symp. on Middle Atmosphere Dynamics and Transport, 341-350, ed. S. K. Avery, SCOSTEP Secretariat, Univ. Ill. Urbana/Champaign.
- Rottger, J. (1981), The capabilities of VHF radars for meteorological observations, ESA SP-165 (Nowcasting: Mesoscale Observations and Short-Range Prediction, Proc. of an International Symp., 25-28 August, Hamburg, Germany (Part of the IAMAP Third Scientific Assembly), 143-148 (Publ. by European Space Agency, Paris, June 1981).
- Rottger, J. (1981), Wind variability in the stratosphere deduced from spaced antenna VHF radar measurements, Preprint Volume, 20th Conf. on Radar Meteorol., Nov 30- Dec 3, Boston, MA, 22-29, AMS, Boston, MA.
- Rottger, J. and G. Schmidt (1981), Characteristics of frontal zones determined from spaced antenna VHF radar observations, Preprint Volume, 20th Conf. on Radar Meteorol., Nov 30 - Dec 3, Boston, MA, 30-37, AMS, Boston, MA.
- Czechowsky, P. (1982), Phasengesteuerte Flächenantenne im VHF-Bereich, NTG-Fachberichte 78, 16-20, VDE-Verlag GmbH, Berlin, Offenbach.
- Czechowsky, P., R. Ruster and G. Schmidt (1982), VHF-Radarmessungen während ALPEX, Annalen der Meteorologie 19, 124-126.

- Klostermeyer, J. (1982), Fernerkundung mit MST-Radars, Ann Meteorol. 18, 91-93.
- Rastogi, P. K. and J. Rottger (1982), VHF radar observations of coherent reflections in the vicinity of the tropopause, J. Atmos. Terr. Phys., 44, 461-469.
- Rottger, J. (1982), Mesosphere-stratosphere-troposphere radar, EISCAT Meetings 82/7, Vol. I (Proc. of the EISCAT Annual Review Meeting 1982, Riksgransen, Sweden, 8-12 March, editor: Kristen Folkstad), 155-169.
- Larsen, M. F. and J. Rottger (1982), VHF and UHF Doppler radars as tools for synoptic research, Bull. Amer. Met. Soc., 63, No. 9, 996-1008.
- Larsen, M. F. and J. Rottger (1982), Analysis of VHF radars and radiosonde data during a frontal passage, Manuscript, Cornell University, EISCAT.
- Ruster, R., P. Czechowsky, G. Schmidt and K. Labitzke (1982), VHF-radar observations in the stratosphere and mesosphere during a stratospheric warming, J. Atmos. Terr. Phys. 45, 161-168.
- Weber, G. R. and R. Ruster (1982), Occurrence of a dry front over the Alpine Region and Central Europe, ALPEX Preliminary Scientific Results, Geneva, December 1982, GARP-ALPEX Series Nr. 7, 108-117.
- Weber, G. R., R. Ruster, and J. Klostermeyer (1982), VHF-Radarbeobachtungen von Frontenpassagen im Voralpengebiet, Annalen der Meteorologie 19, 99-101.
- Czechowsky, P., G. Schmidt and R. Ruster (1983), The mobile SOUSY-Doppler radar - Technical design and first results, Internal Report, MPAE-W-00-83-09, Max-Planck-Institut für Aeronomie, 3411 Katlenburg-Lindau, FRG, 1983.
- Rottger, J., P. Czechowsky, R. Ruster and G. Schmidt (1983), VHF radar observations of wind velocities at the Arecibo Observatory, J. Geophys. Res., 52, 34-39.
- Larsen, M. F. and J. Rottger (1983), Comparison of tropopause height and frontal boundary locations based on radar and radiosonde data, Geophys. Res. Lett., 10, No. 4, 325-328.
- Hocking, W. K. and J. Rottger (1983), Pulse-length dependence of radar signal strengths for Fresnel backscatter, Radio Sci., 18, 1312-1324.
- Hocking, W. K., G. Schmidt and P. Czechowsky (1983), Absolute calibration of the SOUSY VHF stationary radar, Internal Report, MPAE-W-00-83-14, Max-Planck-Institut für Aeronomie, 3411 Katlenburg-Lindau, FRG.
- Rottger, J. (1983), The correlation of winds measured with a spaced antenna VHF radar and radiosondes, Proc. 21st Radar Meteorol. Conf., in press.
- Ruster, R. and J. Klostermeyer (1983), VHF Radar observations of a Kelvin-Helmholtz instability in a subtropical jetstream, accepted for publication in: Geophys. Astrophys. Fluid Dynamics.