

THE GPRIME APPROACH TO FINITE
ELEMENT MODELINGD4
N84 15594

Dolores R. Wallace, James M. McKee and Myles M. Hurwitz

David W. Taylor Naval Ship R&D Center
Bethesda, Maryland 20084

SUMMARY

GPRIME, an interactive modeling system, runs on the CDC 6000 computers and the DEC VAX 11/780 minicomputer. This system includes three components: 1) GPRIME, user-friendly geometric language and a processor to translate that language into geometric entities, 2) GGEN, an interactive data generator for 2-D models; and 3) SOLIDGEN, a 3-D solid modeling program. Each component has a computer-user interface of an extensive command set. All of these programs make use of a comprehensive B-spline mathematics subroutine library, which can be used for a wide variety of interpolation problems and other geometric calculations. Many other user aids, such as automatic saving of the geometric and finite element data bases and hiddenline removal, are available. This interactive finite element modeling capability can produce a complete finite element model, producing an output file of grid and element data.

INTRODUCTION

Finite element analysis has become the predominant method for performing structural analysis on digital computers of all types. Almost any conceivable structure, from a small valve to an entire ship, may be analyzed by the finite element method.

However, the creation of a finite element model of the structure to be analyzed by this method is a major task. Even a small problem can require large amounts of geometric data, with many details to be considered. An engineer can spend a vast amount of time defining the numerical model of a structure and verifying the correctness of this data. The extreme generality of this engineering method has frustrated attempts to create an effective automatic finite element data generator with comparable generality. Finite element models frequently need refinements which require a return to the geometry for more information and details to complete the modeling. Hence, complete geometric data, and efficient management of that data, are essential to make these modifications simple.

The term "geometric modeling" appears frequently in current computer graphics and computer-aided design literature. Many scientists and engineers maintain (correctly) that they have been "modeling geometry" in traditional ways for a great many years. Most recent geometric modeling in the computer-based science has been evolving for more than a decade, but the distinctions between the old technique and the new are significant, even if they sometimes appear to be rather subtle. Although the older geometric techniques could be said to permit the modeling of any required shape, there was little consistency in the representation of different types of objects (ref. 1). Today, good mathematical tools, such as B-spline

functions, are making possible the reality of representing all objects by sets of continuous, well-behaved functions. This development makes possible not only better finite element modeling but also solutions for a wide range of problems in several disciplines of physics.

With GPRIME (ref. 2) the finite element modeling process is automated by providing a geometric representation of the structure while retaining the broad generality of the finite element method. With this complete geometric data base of the structure, both the general data generator GGEN (ref. 3) and the 3-D data generator SOLIDGEN (ref. 4) may be used to produce the finite element model necessary for structural analysis. The basic assumption of the GPRIME approach is that, if a systematic and accurate mathematical model of the geometry of a structure could be stored in the computer, the task of creating general finite element data generators would be greatly simplified. The advent of low cost, interactive computer graphics makes the GPRIME approach even more attractive, since problem areas in an automatically generated model can be easily resolved by interactive methods at the graphics screen.

The Navy and DTNSRDC have long been interested in geometric modeling techniques. Since 1976, the Numerical Structural Mechanics Branch of the Computation, Mathematics and Logistics Department has been developing a geometric modeling system consisting of the B-spline mathematical tools to define geometric representations, a geometric language to access this modeler, and the interface needed for implementing it interactively on a computer. This language, called GPRIME, was originally formulated to support finite element data generation for structural analysis. As indicated earlier, two data generation programs are now available for use with the GPRIME geometry: GGEN, for general interactive modeling including the two-dimensional shell-type element and SOLIDGEN, for generating three-dimensional solid models. GPRIME, GGEN, and SOLIDGEN were first developed for use on the CDC 6000 and CYBER computers under the NOS and NOS/BE operating systems, and are now also operating on the DEC VAX 11/780 minicomputer. The graphics capabilities assume that Tektronix storage-tube type graphics terminals will be used. The programs may be used in batch or interactive-graphics modes, or mixed modes. The programs use the RATFOR pre-processor for structured FORTRAN.

GPRIME COMPUTER GRAPHICS: A GEOMETRIC MODELING SYSTEM

Geometric Constructions

- * Classical primitives of geometry
- * B-spline mathematical functions, in 1, 2, and 3 dimensions
- * Parametric representations independent of analysis model
- * Rotations, translations, scaling of geometry
- * Geometry generation from digitized data, keyboard or cursor definition, or combination

Graphic Display and Viewing Options

- * Hidden line removal
- * Rotating, translating, scaling display of geometry
- * Selection of geometry items to be displayed
- * Status of all viewing, plot, axes parameters

- * Program-to-user messages
- * Annotation of geometries, definitions, names, at screen

Generation of Finite Element Models

- * Data generation for 2-D plate/shell elements, general elements
- * 3-D solid element generator
- * Output formatter

Processing Controls

- * Interactive and batch operating modes
- * Restart capability
- * HELP messages on definitions, commands, as requested by user

Applications

- * Hydromechanics modeling, structural finite element analysis, ship magnetostatic signatures, thermal analysis
- * Potential application in ship vulnerability, infrared detection, cost and weight estimation, CAD/CAM, composite studies.

EVOLUTION OF GEOMETRIC MODELING: THE PATH TO GPRIME

During its evolution, geometric modeling has taken many forms. Its "correct" description is discussed in many forums today. Designer's sketches and engineering drawings have long been thought of as geometric models. The fact that this type of representation is heavily laced with graphic shorthand and engineering insight becomes obvious when we begin to ask computers to translate these drawings into instructions for manufacturing the parts described on these drawings. Achieving this automation requires that a computer be provided with all the details of the draftsman's shorthand, so that it can "understand" the old drawings, or that it be provided with sufficient geometric information rather than engineering terms such as "fillet" in model descriptions. Both developments are taking place, i.e., direct reading from blue prints and more complete numerical input data, but the complete geometric representation appears to be the key to large-scale automation.

Discrete finite element models are now routinely used for structural analysis. These models are usually thought of as rather elegant geometric models, but are of no use in defining a machine cutter path, and really of little use to a finite element analyst who requires models with a more detailed mesh. Coordinate information for constructing finite element models is defined at a discrete number of points-period. Some sort of interpolation may be used on this data to find intermediate points, but because the finite element data points were created to meet the requirements for one specific analysis, those points may not represent the basic detailed geometric shape of the structure.

From work with early computers and primitive computer graphics techniques, automatic drafting programs emerged. These programs "spoke" in the language familiar to draftsmen. Soon designers wanted to connect this type of program to programs that guided numerically controlled tools. These marriages have become or are now evolving into computer-aided design and computer-aided manufacturing (CAD/CAM) systems. To accommodate these new demands, the designer's language has

evolved from the draftsman's, with the addition of a vocabulary of geometric shapes and geometric operations. Intersections of classical cylinders with complex "sculptured surfaces," (ref. 5) as in Figure 1, make the definition of true three-dimensional geometric representations considerably easier than drawing with the draftsman's two-dimensional notation.

We have used the term "old geometry" to collectively refer to the many different computer methods used to describe geometric shapes, which, by their nature, are limited to certain special applications. Some of these methods are the closed form polygonal approximations of spheroids and ellipsoids, the ellipsoidal modeling of airplanes and submarines, and point by point finite element descriptions. Similarly, we have used "new geometry" to refer to evolving methods of geometric description. These descriptions attempt to be mathematically complete for any application and to permit manipulation of all geometric forms without having to resort to special processing for different combinations of valid representations. For example, the B-spline mathematical functions afford good data representations of a structure. The new geometry has obvious roots in the old; however, the new approach represents attempts to develop a general solution to the geometric modeling problem, whereas the older geometries were developed to solve particular problems.

The new geometry has not come into the world without its share of growing pains. As new capability is added to older techniques, program developers have attempted to maintain compatibility between the old forms and the new forms of geometry. As more of the properties of the new geometry are exploited, it becomes more difficult to maintain compatibility. Either the old forms will have to be abandoned, or translators will have to be created to produce an equivalent new form for the old definitions. Similarly, once we have a very convenient way to represent geometry and to combine forms easily, the modeler's creativity can quickly outstrip the available mathematics. For example, volume intersections computed using "old" techniques may yield only edges of boundary which can be drawn; this is insufficient to completely define a new volume because there is not information on how the function varies through the volume. These problems are evident in the technique known as "combinatorial geometry," (ref. 5) which permits boolean operations on three-dimensional solids. If simple unions and intersections are permitted without restriction, it is easy to imagine how a few simple shapes could mushroom into a computationally-intractable situation. Often, these problems can be avoided by limiting the number of combinations or by deferring the boolean operations until they can be handled by later applications programs in which a knowledge of the final product can simplify the choice of functional representation.

The need for complete geometric description has also been evolving in other areas of computer simulation. Finite element and finite difference modeling can be easily automated if an adequate geometric description is available. Numerical solutions, which require that new meshes be generated at various points in the computation, demand such a representation, once the models advance from simple classical shapes to the complexities of the real world. The rest of this report briefly describes: GPRIME for providing geometric representations and UGEN and SOLIDGEN which use this geometry for finite element modeling.

GEOMETRIC LANGUAGE PROCESSOR: GPRIME

Overview

As the finite element method gained popularity with structural engineers, the need for an accurate finite element model that could be developed in a reasonable time at reasonable cost became obvious. The computer program GPRIME, a geometric modeling system, provides the geometry for these finite element methods. GPRIME addresses the requirements for a practical geometric modeling system—mathematical representation, man-machine interface, data base management, and implementation (ref. 6). The geometry is defined in GPRIME via a geometric language of definitions and commands that simplifies the creation of complex models. Classical shapes are defined using straight-forward expressions, and more general curves and surfaces can be defined using digitized coordinate data. By using the B-spline mathematical functions, GPRIME can provide the engineer with a complete geometric model, constructed with well-behaved continuous functions, independent of the discrete model used in the analysis.

The GPRIME processor itself uses interactive computer graphics to define geometric entities and to aid in visualizing the model being created. The processor creates a geometric data base (referred to as UMF - user master file) which may be used for restarting the definition process at later sessions and for communication with user's programs. The implementation of GPRIME allows the user various controls over the entire system.

The Geometry Modeler

From construction drawings, tool cutter data, digitized data, measurements, or other forms of model description, the engineer may begin to define a geometric model with a combination of either general curves and surfaces, or with classical forms of geometry. These classical forms include points, lines, arcs, circles, cylinders, cones, spheres, and surfaces of revolution. These entities are represented internally by B-spline functions, which are also useful in smoothing and fitting applications, as shown in Figure 2. The parametric representations of these entities make it easy to locate points and curves of intersection in complex geometric configurations. In fact, the intersection capability provides a very useful tool for data-checking of models of complex structures.

Rotations, translations, and scaling of the geometry are available through the GPRIME language. GPRIME was designed for use in creating finite element structural analysis models, but it can be applied wherever a geometric description of an object is required. A set of user-callable subroutines is available for user access to the internal B-spline definitions stored on a UMF (user master file from GPRIME) data base. These subroutines are referred to as the GPRIME Data Base Access Capability (GDBAC).

Design Aids

Special GPRIME commands provide the capabilities of controlling model changes, viewing options and other user aids. The user may delete or change any part of a constructed geometrical model, and the GPRIME processor will automatically change any of the components dependent on or affected by the geometrical changes.

Viewing options allow the user to control the viewpoint, as well as to effect translations, hidden line removal, and rotations. The hidden lines have been removed in the propeller shown in Figure 3. Plotting options permit plots of all or some of the curves, surfaces, points or user-defined groups of data. An optional status table shows the current status of plotting, viewing, printing, and axes options. The printing options are provided for annotation of various tables on the screen. A command also permits the user to obtain an output file containing the definitions and commands used in a session. An interactive call for HELP gives the user instructions as needed in using these commands and definitions. Executive control permits the initial session to begin with an input file of definitions and to restart later sessions from the saved geometric data base. GPRIME also provides a macro facility which contains a user-defined set of GPRIME commands. For frequently used procedures, such as defining two surfaces and their curve of intersection, or frequently used viewing options, the user can, via the macro command, execute in one line several previously defined statements.

In summary, GPRIME provides powerful generation algorithms for developing a geometrical model from which finite element models may be generated. The geometry may be used in a variety of applications, such as smoothing functions, data-checking, ship vulnerability studies, or wherever geometry is required. Additional GPRIME capabilities include viewing, plotting, editing, and file options enabling the engineer to significantly reduce the time required for model generation. Finally, the GPRIME data base is available for use by user programs.

INTERACTIVE DATA GENERATOR: GGEN

Overview

With the availability of a general geometric language processor, such as GPRIME, which provides a data base of a representative geometric model, finite element modeling becomes easier and more complete. GGEN is a computer program for creating finite element models from an interactive computer terminal. GGEN is different from most other finite element data generators in that it references geometric information that has been defined using the GPRIME geometric language. One advantage of the GPRIME-GGEN approach includes the ability to define interactively a three-dimensional model from a two-dimensional terminal screen or digitizing board.

GGEN Procedures

The GGEN generator has been implemented as a module of the GPRIME language processor. This implementation permits GGEN to use many of the graphics and data management features of GPRIME. These features include GPRIME processing of changes, print options, HELP messages, new geometry, and access to existing geometry. All these processes may be performed interactively, one at a time, with program control remaining in GGEN. However, if the user wishes to return to GPRIME, GGEN will automatically save GGEN data.

Any GPRIME geometry, such as points, curves, surfaces, or groups of these, may be referenced by GGEN at any time during an interactive session. The first curve or surface activated is the default, that is, the curve or surface from which new

elements are created, unless another curve or surface is referenced by a given command. The number of curves, surfaces, and groups which may be active at one time is limited by user specified parameters. Commands are provided to remove unneeded items, including points, from the list of active geometries.

Data Generation and Display

Node points and elements can be created in a bulk mode by using one command with various options. These options include generating points, elements, or both. Such bulk generation will produce a "uniform" mesh on the specified reference curve or surface. Prior to the bulk generation, the user may enter another command to cause broad variations in the mesh.

Although GGEN automatically numbers nodes and elements, an option exists to assign numbers to the nodes and elements. Points and elements may also be defined individually or in small groups. In one command, both passive (type-in) and interactive (cross-hairs, tracking cross) methods are used. In the other, the user selects from a user-menu, that is, a set of instructions printed on the screen, to perform the various creation functions interactively.

Deletion of nodes and elements is similar to the creation process, either by using a type-in command or by making a menu selection. Note: GGEN assumes the usage of a storage tube type terminal, meaning that any item drawn remains until the entire screen is erased. Deleted items will be marked deleted with an "X" until the picture is redrawn. Any item so marked can be restored later, if the item was deleted by mistake.

By entering the EDIT command, the user may perform most GGEN functions under interactive control. In this mode the user selects a function to be performed from a list, called the menu, displayed on the right side of the screen. (see Figure 4.) The user indicates the desired function by moving the terminal's crosshair cursor inside the box enclosing the function name on the menu. Alternatively, the function may be selected using the keyboard by entering the character displayed at the left of the name of that function. GGEN acknowledges the user's selection by highlighting the box that encloses the name of that function.

The menu functions permit the user to delete and create nodes and elements by selecting node points and elements on the screen with the cross hair cursor.

The user can selectively display GGEN points, curves, surfaces, and elements as in GPRIME. Items may also be identified with labels as the user chooses. One command allows the redisplay of all currently defined items under the control of the current plot parameters. The piping tee in Figure 5 uses the option to shrink element representation away from associated node points. Any new items included in the parameter list of this command will also be plotted.

Output

All generated finite element data may be passed to a local file, "FEDATA," using a punch command. Point data, element data, or both can be put on this file. All current data can be entered or, optionally, only those items that have changed

since the last usage of the command. This output file is available to the user for direct input to finite element programs or for later editing.

GENERATING THREE-DIMENSIONAL SOLID STRUCTURES: SOLIDGEN

Overview

The first proposed application of the GPRIME geometric modeling approach was for the generation of three-dimensional solid finite element models. The proposed concept consisted of two parts. First, GPRIME surfaces would be defined to bound the structural model. Then, a data generation program would generate brick-like solid elements on the interior of a defined volume.

The SOLIDGEN program was developed to implement the data generation concept. There was no restriction on the GPRIME surface used to bound a SOLIDGEN model and those boundary surfaces may either define a face of the model or extend beyond the region being defined, whichever the user finds more convenient. The shape of the generated elements is governed by the bounding surfaces and additional reference surfaces provided by the user.

SOLIDGEN Technique

To generate a satisfactory finite element model with SOLIDGEN, the user must first visualize the general shape of the generalized model. For example, will the elements lie in more or less concentric rings about a cylindrical recess or will they make up a rectangular brick-work? This type of information is conveyed to SOLIDGEN by selecting and ordering the reference surfaces in such a way that they form a mesh of six-sided super elements, called zones. The generated elements will follow the general pattern defined by these zones.

The three diagrams of Figure 6 demonstrate the procedure from sketch through the geometry to the solid element model of a globe valve. The designer has marked an octant of the symmetric valve with reference surfaces shown in Figure 6a. Together, these six-sided super elements define the boundary of the solid model. The geometry required by SOLIDGEN here is not an exact detailed structure but rather the general bounding surfaces or surfaces of revolution seen in Figure 6b. SOLIDGEN builds the brick elements of Figure 6c from these surfaces. The output file contains all the grid point and element data.

CONCLUSION

Although GPRIME's biases are toward the solution of research and development problems, obviously there are many other areas of potential application. From early in its development it was clear that GPRIME would provide a powerful geometric capability useful for many scientific applications. Thus, it comes as no surprise that GPRIME is being used for hydromechanics modeling, for ship vulnerability studies, and for infrared modeling as well as for generating finite element data. It offers potential use in simulation, in finite element modeling of composites, and in cost and weight estimation problems. In the manufacturing area, its possible applications to computer-aided design and computer-aided manufacturing procedures seem obvious.

A library of B-spline subroutines makes it a simple task for program developers to include GPRIME geometry in their programs. The data generators GGEN and SOLIDGEN were the first example of using these internal routines for specialized applications, in this case, to address the needs of finite element analyses.

GPRIME and its data generators have been providing a strong geometric capability, at the forefront of geometry modeling. In their present form, they do require continual maintenance on several computer systems in order to ensure their usefulness. However, many extensions can be made that would enhance their usefulness to Navy programs. For example, the mathematics routines can be expanded to include multiple intersection points. Better display characteristics and improved user-computer interface methods would help the user. Other enhancements could permit graphical changes in the geometry, a more general output format, and the addition of more elements. Improved data-handling techniques could make the data base access even more efficient. As these mathematical and computer science ideas become realities in GPRIME, it will become easier to solve larger and more complex problems.

REFERENCES

1. McKee, J.M.; and R.J. Kazden: GPRIME B-Spline Manipulation Package--Basic Mathematical Subroutines. DTNSRDC Report 77-0036 April 1977.
2. McKee, J.M. et al.: GPRIME: A Geometric Language for Finite Element Modeling Program Manual. DTNSRDC Report 82/062 Sep 1982.
3. Wallace, D.R. and J.M. McKee: GPRIME/GGEN Interactive Finite Element Data Generator. DTNSRDC Report (in publication).
4. Kazden, R.J.: The GPRIME-SOLIDGEN Finite Element Modeling Capability. Second Chautauqua on Productivity in Engineering and Design, the CAD Revolution, Nov. 15-17, 1982.
5. Requicha, A.A.G.; and H.B. Voecker: Solid Modeling: A Historical Summary and Contemporary Assessment. IEEE Computer Graphics and Applications, pp. 9-24, March 1982.
6. Requicha, A.A.G.: Representations for Rigid Solids: Theory, Methods, and Systems, ACM Computing Surveys, Vol. 12, No 6, pp. 437-464, December 1980.

ORIGINAL PAGE IS
OF POOR QUALITY

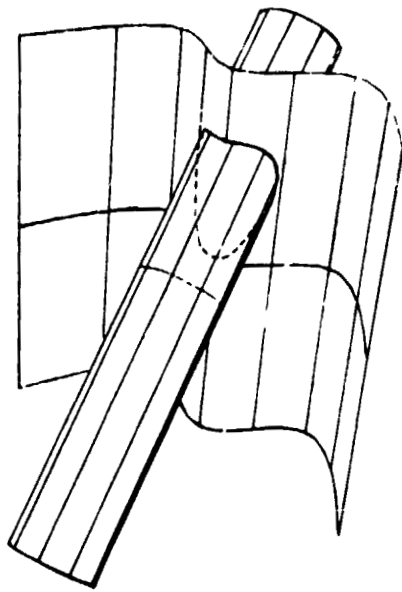

Figure 1 - Two-Surface Intersection

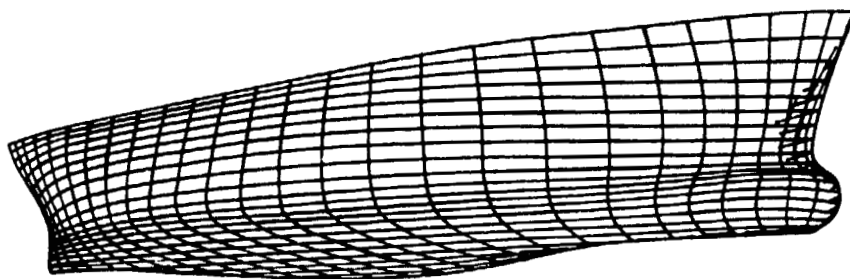

Figure 2 - Ship Hull

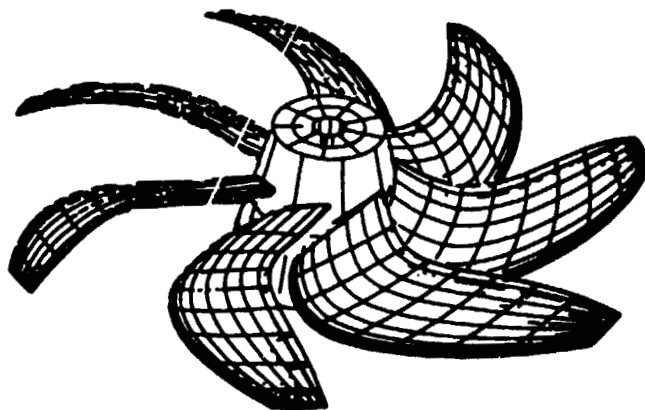

Figure 3 - Marine Propeller, Hidden Lines Removed

ORIGINAL PAGE IS
OF POOR QUALITY

| | |
|----|--------------------------|
| A. | REDRAW WORKSPACE |
| B. | SWITCH TABLET/CROSS |
| C. | ALIGN MENU (UL,LR) |
| D. | ALIGN ORTH (PT1,PT2,PT3) |
| E. | E N D (INPUT/EDIT) |
| | |
| G. | DELETE NODES |
| H. | (CHANGE) |
| I. | (LAST) |
| J. | DELETE ELEMENTS |
| K. | (CHANGE) |
| L. | (LAST) |
| M. | CREATE NODES |
| N. | CREATE ELEMENTS |
| O. | ELEMENTS + NODES |
| P. | 2 NODES/ELEM. |
| Q. | 3 NODES/ELEM. |
| R. | 4 NODES/ELEM. |
| | |
| Z. | REPEAT MESSAGE |
| | * TASK COMPLETED |
| | ** IMPROPER OPTION |
| | *** MISSED BOX |
| | **** POINT NOT ON C/S |
| | ***** OTHER |
| | |
| 0 | ZVAL |
| *1 | S1 |
| 2 | S2 |
| 3 | C3 |

Figure 4 - GGEN/EDIT Menu

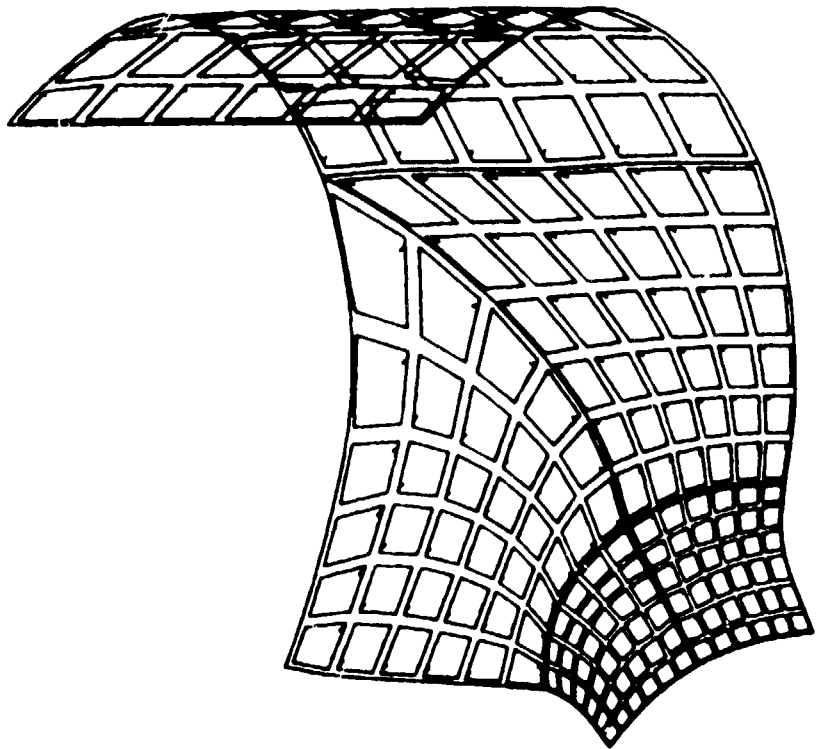

Figure 5 - Piping Tee, Element Shrink

ORIGINAL PAGE IS
OF POOR QUALITY

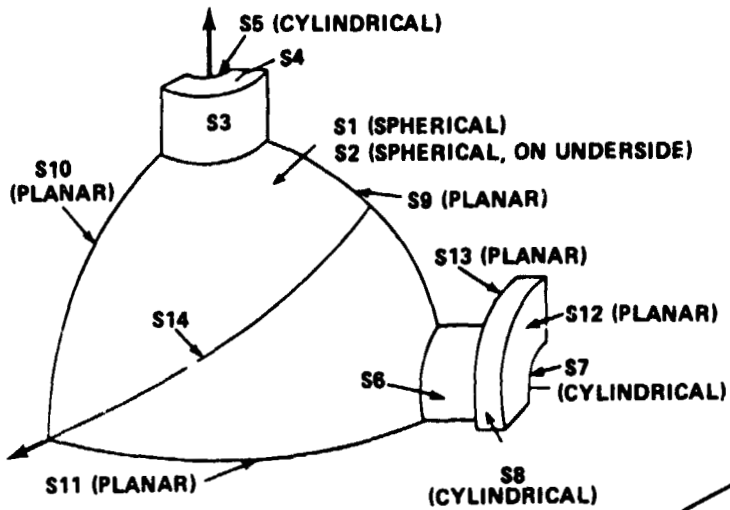

Figure 6a - Engineer's Sketch

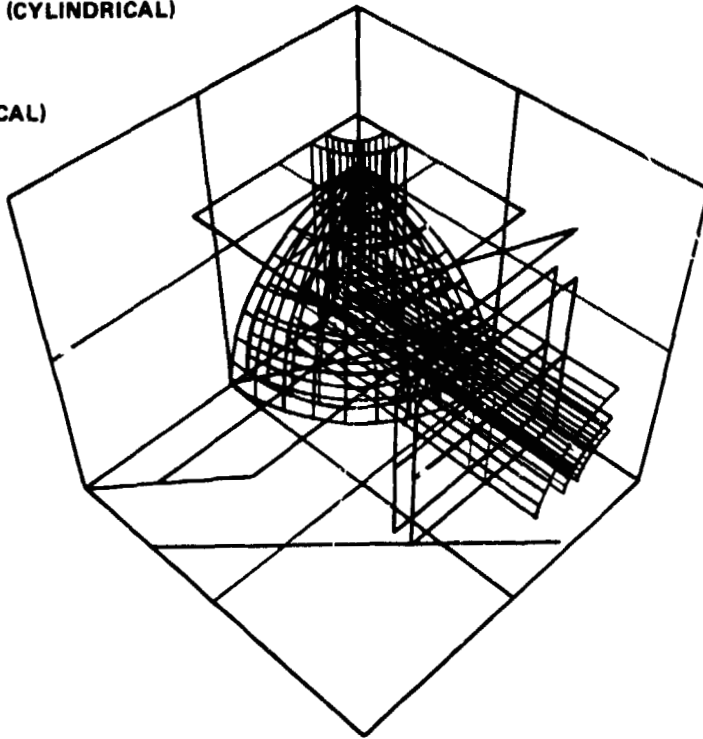

Figure 6b - Geometry

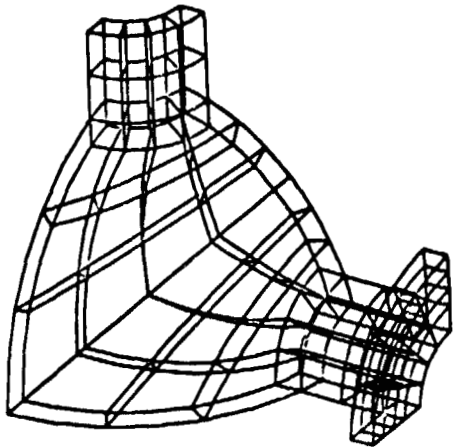

Figure 6c - Solid Element Model

Figure 6 - Globe Valve, from Sketch to Solid Elements