

DESIGN OF AN ADIABATIC DEMAGNETIZATION REFRIGERATOR
FOR STUDIES IN ASTROPHYSICS

by

Dr. Stephen Castles
Cryogenics, Propulsion and Fluid Systems Branch
Space Technology Division
National Aeronautics and Space Administration
Goddard Space Flight Center
Greenbelt, Maryland

ABSTRACT

An adiabatic demagnetization refrigerator has been designed for cooling infrared bolometers for studies in astrophysics and aeronomy. The design has been specifically tailored to the requirements of a Shuttle sortie experiment. The refrigerator should be capable of maintaining three bolometers at 0.1 K with a 90 percent duty cycle. There are great advantages in operating the bolometers at 0.1 K rather than at the 1.5 K that can be attained with a space-pumped liquid helium cryostat. These advantages are: greater sensitivity, faster response time, and the ability to use larger bolometer elements without compromising the response time.

The design presented in this paper is the first complete design of an ADR intended for use in space. The requirements of space, as well as the requirements of the bolometers that are being cooled, create a number of specifications that have not been incorporated into previous ADR designs. The most important of these specifications are to survive a Shuttle launch, to operate with 1.5 K - 2.0 K space-pumped liquid helium as a heat sink, to have a 90 percent duty cycle, and to be highly efficient.

The first unit, called the engineering model, has been designed and fabricated. This engineering model will satisfy the basic operational and structural requirements for flight. It will be functionally tested at the GSFC in the near future.

INTRODUCTION

The adiabatic demagnetization refrigerator (ADR) described herein was designed specifically for cooling infrared bolometers to 0.1 K. There are great advantages in operating the bolometers at 0.1 K rather than at the 1.5 K that can be attained with a pumped liquid He⁴ cryostat. These advantages are: greater sensitivity, faster response time, and the ability to use larger bolometer elements without compromising the response time. The latter two advantages result from the decreased heat capacity of the bolometer at the lower temperature. In addition, the photon noise of the sensor is reduced, which improves its sensitivity.

In the absence of the photon noise, the detector sensitivity is limited by the Johnson noise and the temperature fluctuation noise. This sensitivity can be characterized by the detector noise equivalent power (NEP). For a bolometer with a given time constant, the NEP that may be achieved varies with the detector temperature T as:

$$\text{NEP} \sim T^{5/2} \quad (1)$$

It can also be shown that

$$t^5 \sim \text{NEP}^2 \quad (2)$$

where t is the observing time necessary to obtain data with a certain accuracy. From equation (1) and (2), one finds that operation of bolometers at 0.1 K with an adiabatic demagnetization refrigerator, rather than at 1.5 K with pumped liquid helium reduces the NEP by a factor of 870 and reduces the observing time by a factor of 700,000.

As mentioned, equations (1) and (2) are valid only for bolometers with time constants independent of the temperature. Unfortunately, the time constant of certain types of bolometers increases at low temperatures as the temperature is decreased. For these bolometers, the decrease in the NEP and the observing time will be less than the decrease derived from equations (1) and (2). However, for an infrared bolometer properly designed for use at low temperatures, the improvement in the NEP and the observing time should be considerable.

Due to the great advantages of operating bolometers at lower temperatures, the 0.1 K adiabatic demagnetization refrigerator (ADR) development program was initiated at the GSFC. The goal is to develop a highly reliable ADR capable of withstanding a Shuttle launch and capable of operating in the 0-g environment of space.

The first unit, called the engineering model, has been designed and fabricated. Final assembly and testing is on-going. This engineering model will satisfy the basic operational and structural requirements for flight. However, some modifications will be required for a flight unit. The following sections describe the design of the engineering model ADR and the modifications that will be required for the flight unit.

OPERATING CHARACTERISTICS

The operating characteristics for the GSFC engineering model adiabatic demagnetization refrigerator were developed in meetings with infrared astronomers, namely Dr. Michael Hauser and Dr. John Mather. These operating characteristics are summarized in Table 1. They include an operating temperature of 0.1 K, better than $10\mu\text{K}$ temperature stability, $50\mu\text{W}$ cooling power, and observing time for the cooled bolometers of at least 90 minutes. To achieve a 90% duty cycle, the time necessary to recycle the ADR is limited to 10 minutes. Also, since the total cooling capacity of the stored liquid helium in the spacecraft is limited, the heat load expelled to the helium by the ADR must be held to a minimum. To accomplish this goal, the ADR should be highly efficient.

Table 1

Adiabatic Demagnetization Refrigerator

- o Operating Temperature is 0.1°K
 - Higher operating temperatures possible with greater cooling power
 - Excellent temperature stability
- o $50\mu\text{W}$ Cooling Power
- o Operating Time Greater than 90 Minutes
 - Recycle time of 10 minutes
- o Highly Efficient
 - Thermodynamic efficiency approaches Carnot
 - Expels less than 2mW to the liquid helium bath
- o High Reliability
 - No moving parts
- o Mechanical Design Appropriate for a Shuttle Launch

PRINCIPLE OF OPERATION

The key component in an ADR is the paramagnetic salt. This salt contains ions of metals that have a net magnetic moment. The magnetic moments of different ions interact with one another, the strength of the interaction being dependent on, among other factors, the spacing between the ions. This interaction will cause the magnetic moments to "order" below some temperature. The paramagnetic material (a salt crystal in our case) will then be ferromagnetic or antiferromagnetic. For example, in iron the spacing is small and the magnetic moments are ordered at room temperature. In paramagnetic salts used in an ADR, the spacing must be large so that the magnetic moments will not be ordered at the operating temperature of the refrigerator. For this reason, hydrated salt crystals are generally utilized in an ADR. Hydrated crystals containing cesium, chromium, iron, manganese, and gadolinium have been utilized with ordering temperatures ranging from a few milli-Kelvin (mK) to a few Kelvin.

When the magnetic moments are not ordered, the collection of magnetic moments has associated with it a relatively large quantity of entropy, S . However, the magnetic moments of the ions can be aligned (ordered) by applying a sufficiently large magnetic field. As the magnetic moments align, the entropy associated with the collection of magnetic moments decreases. If this decrease in entropy, ΔS , occurs at a constant temperature, T , a quantity of heat, ΔQ , given by

$$\Delta Q = -T \Delta S$$

is produced by the alignment of the magnetic moments. If the magnetic field is removed, an equal quantity of heat, $\Delta Q = T \Delta S$, will be absorbed by the collection of magnetic moments as the moments unalign. This heat absorbed by the change in entropy associated with the magnetic moments of the metal ions, provides the cooling power of the ADR.

An ideal adiabatic demagnetization cycle is depicted in Figure 1. The entropy-temperature diagram for ferric ammonium sulfate is presented in Figure 1a for various magnetic fields. The dashed line connecting points 1, 2, 3 and 4 represents the cycle through which an ADR operates. Figure 1b presents four sketches of an ADR illustrating the position of the heat switch (conducting or nonconducting) and the strength of the magnetic field at the four stages of the demagnetization cycle. These stages correspond to points 1, 2, 3 and 1 again in Figure 1a.

At the beginning of the demagnetization, point 1, the heat switch is closed and the magnetic field has its maximum value. The heat switch is then opened and the field rapidly decreased until the desired operating temperature (0.1 K in this case) is reached (point 2 in Figure 1a). Then the field is slowly decreased such that the heat absorbed, Q_A , by the spin system equals the heat load on the refrigerator. The dashed line between point 2 and point 3 corresponds to this isothermal demagnetization.

When the magnetic field reaches zero (point 3), the heat switch is closed and the salt is rapidly magnetized, corresponding to the dashed lines from point 3 to point 4 to point 1. The heat expelled from the spin system, Q_B , is conducted to the helium bath between point 4 and point 1. Once the heat is removed, the cycle can be repeated. It should be noted that the efficiency of the ideal adiabatic demagnetization cycle is equal to the Carnot efficiency. Therefore,

$$\frac{Q_A}{Q_B} = \frac{T_B}{T_A}$$

NEW DESIGN REQUIREMENTS FOR THE GSFC REFRIGERATOR

The design presented here is the first complete design of an ADR intended for use in space. The requirements of space, as well as the requirements of the bolometers that are being cooled, create a number of specifications that have not been incorporated into previous ADR designs. The most important of these specifications are the following:

- . Survive a Shuttle launch.
- . Operate with 1.5 K - 2.0 K space pumped liquid helium as a heat sink.
- . Produce a minimum heat load on the stored helium to extend the cryogen lifetime.
- . Have a 90% duty cycle.
- . Have a temperature stability of better than 10^{-6} W, with a goal of 1μ W.
- . Incorporate a superconducting magnet that can be easily qualified for spaceflight.

SUMMARY OF THE DESIGN FEATURES

A sketch of the GSFC refrigerator as it will be operated in the laboratory is presented in Figure 2. The part of the ADR that is cooled to 0.1 K is called the "cold section" (see figure 3). It consists of the lower part of the heat switch, the paramagnetic salt-copper wire structure in its cylindrical container (often called the salt "pill"), the detector mount, and the copper wires and stainless steel stiffeners connecting these

elements (see figure 3). The continuous fill He⁴ refrigerator will be pumped with a vacuum pump to obtain 1.5 K to 2.0 K. The superconducting magnet and the vacuum can containing the cold section will be submerged in liquid helium at 4.2 K.

Since the design of the ADR is lengthy and complicated, a summary of the finalized design is presented here. A more detailed description of the design features of each subsystem can be obtained from the author.

a. Demagnetization System: Magnet, Salt, and Magnet Control Loop:

The ADR is designed to utilize a reliable and inexpensive NbTi superconducting magnet. The rated field in the paramagnetic salt varies from 3.4 T (1 Tesla = 10,000 Gauss) to 4.5 T and averages over 4.0 T.

The cylindrical salt pill is 8.89 cm long and 5.08 cm in diameter. It has a layered construction alternating slabs of salt 1.6 mm thick with sheets of 0.2 mm diameter, 99.999% pure copper wire. All voids are filled with Apiezon J-oil to ensure good thermal conductance. The pill contains 175 gm of ferric ammonium sulfate salt, $\text{Fe}(\text{NH}_4)(\text{SO}_4)_2 \cdot 12\text{H}_2\text{O}$. This amount of salt can provide 50 μW of cooling for 95 minutes at 0.1 K with a 25% margin for cooldown losses.

To obtain adequate temperature stability to operate bolometers at 0.1 K, it is advantageous to control the temperature of the salt by controlling the demagnetization with a feedback loop. The elements of the feedback loops are shown in Figure 2. A calibrated germanium resistance thermometer is thermally anchored to the salt pill. Its electrical conductance is measured with an S.H.E. Model PCB conductance bridge. The off-balance signal from the bridge is then tailored with a Linear Research Model LR-130 temperature controller and fed into an active integrator. The active integrator provides a ramp voltage signal to the HP 6260 D.C. programmable power supply, which in turn provides the current to operate the superconducting magnet.

The temperature stability provided by this feedback loop is determined primarily by two factors:

1. The sensitivity of the Model PCB bridge in conjunction with the germanium resistance thermometer. This sensitivity is on the order of 0.01% of the temperature at 100 mK.

2. The time constant of the feedback loop.

The smaller the time constant of the feedback loop, the smaller the temperature excursions will be before they are corrected. In an ADR, the magnetic moments of the metal ions, often called the "spin system," responds very rapidly to small changes in the magnetic field. Also, the

time constant between the spin system and the lattice of the salt is negligible at 0.1 K. In addition, the relatively high thermal conductivity (for 0.1 K) of the salt crystals causes the thermal time constant of the salt to be very short. The only remaining time constant, the thermal time constant between the salt and the germanium resistance thermometer will, therefore, be the longest single time constant in the feedback loop. This time constant can be made quite short by ensuring that good thermal contact is made between the salt and the resistance thermometer, and that no significant heat capacity is thermally anchored to the germanium resistor.

The relatively short time constant of this feedback loop results in superior temperature stability. This short time constant is one of the important assets of an ADR.

b. Structural Design:

As mentioned, the primary purpose of this ADR is to provide reliable refrigeration for bolometers in the 0-g environment of space. To meet this requirement, the refrigerator must be able to survive a Shuttle launch. The GSFC design has incorporated this requirement.

The cold section of the refrigerator is attached to the nominally 2 K He⁴ pot by the nylon cylinder connecting the two ends of the gas gap heat switch. Additional support is provided by 32 Type 101 nylon wires attached to nylon rings located at various points along the cold section. Nylon is not the optimum material but rather was chosen for its ready availability.

The end of the nylon wires at 2 K are also attached to nylon rings. These rings are supported by four sturdy rods spanning the length of the cold section and equally spaced around it. The nylon cylinder and wires must provide less than a 50 μ W heat leak to the cold section. For this reason, they are the critical elements in the mechanical design. Other parts of the structure can be made quite rigid. For example, the cold section is made both sturdy and rigid by placing thin wall stainless steel tubing between the salt pill and the heat switch, and between the salt pill and the detector mounting plate.

The critical components of the structural support system have been analyzed by M.T.P. Chan of the GSFC Structural Loads and Analysis Section. The structural analysis shows that the support system will survive a Shuttle launch with a margin of safety of 5.7.

c. Thermal Design:

c.1 The Cold Section:

Temperature differences between various sections of an ADR may significantly degrade the performance of the refrigerator. Therefore, the most important consideration in the thermal design of an ADR is to limit these temperature differences. The temperature differences result from and are maintained by the heat load on one section of the refrigerator being conducted to another section. Since these heat loads differ for each part of the demagnetization cycle, the temperature differences must be calculated for each part of the cycle.

During the isothermal demagnetization at 0.1 K, the heat load on the bolometers is conducted to and absorbed by the salt. Taking the total heat load on the bolometer mount to be $25 \mu\text{W}$ (a very conservative assumption), the temperature difference between the salt and the bolometer mount is calculated to be less than 8 mK. An 8 mK temperature difference will require the salt to be maintained at 92 mK in order to maintain the bolometer mount at 100 mK. This would reduce the cooling power of the salt by 8%. But, the salt pill in the GSFC refrigerator is designed with a 25% margin on the cooling power so the ADR will still meet its design goals.

For the demagnetization of the salt from 2 K to 0.1 K, the primary heat load on the refrigerator is due to eddy current heating and due to the removal of the enthalpy of the refrigerator (other than the enthalpy of the spin system). Fortunately, the enthalpy of the entire cold section of the refrigerator, exclusive of the salt spin system, is much less than the enthalpy of the spin system itself. Furthermore, the eddy current heating is also small. The calculated total loss of cooling power due to these parasitic heat loads will be less than 2%. Since this loss is so small, the details of the thermal design during this phase of the demagnetization are immaterial.

Only the essential features of the thermal design of the cold section have been presented here. By historical standards, an unusually thorough thermal design was performed on the GSFC refrigerator.

c.2 Thermal Conduction of the Mechanical Support Structure:

The thermal conductivity of type 101 nylon (density = 1.141 gm/cc) has been well characterized at low temperature.¹ At 2 K, its conductivity is given (conservatively) by $K = 50 \mu\text{W/cm K}$. Using this value of K as \bar{K} (another conservative approximation) in

$$Q = \frac{\bar{K}A}{L} \Delta T$$

¹ R.J. Kolouch et al, J. Apl. Phys. 39, 3999 (1968)

we find that the heat leak through the 32 nylon support wires is less than $9\mu\text{W}$ when the support bracket is at 2 K. The heat leak through the 40 mil thick nylon cylinder of the gas gap heat switch is less than $18\mu\text{W}$. Thus, the total heat leak through the mechanical support system is less than $27\mu\text{W}$.

d. Gas Gap Heat Switch:

The GSFC refrigerator is designed specifically for flight on a Shuttle sortie mission. To store liquid helium for a Shuttle sortie requires a relatively long lifetime storage dewar. With present dewar technology, all such dewars have at least one vapor cooled shield to intercept the radiation between the liquid helium and the typically 300 K outer shell of the dewar. Due to the appreciable tubing length required by such vapor cooled shields, long lifetime storage dewars have appreciable flow impedance in the vent lines. It is estimated that this flow impedance will, in general, be sufficient to prevent space from pumping liquid helium to much less than 1.5 K. Therefore, if the ADR is not to impact the liquid helium dewar design, it must be capable of operating with liquid helium in the range from 1.5 K to 2.0 K.

In contrast to this requirement, all ADRs have historically operated either with an He^3 refrigerator or with an He^4 refrigerator at 1.0 K. At these temperatures, a lead superconducting heat switch can be utilized. However, with space pumped helium at 1.5 K or above, the superconducting heat switch has a very poor on/off ratio. Therefore, a new heat switch capable of functioning at higher temperatures was required. To fill this need, a getter-operated, gas gap heat switch was designed. The heat switch consists of two copper end pieces separated by a narrow "gas gap." The volume in the gap is connected to a small zeolite getter capable of pumping helium to a pressure of less than 10^{-6} torr. At these pressures, the conduction across the gas gap is much less than the $9\mu\text{W/K}$ thermal conductance through the nylon cylinder connecting the two copper end pieces. By heating the getter to 10 K to 20 K, enough helium can be driven off to raise the pressure of the gas gap to 10^{-1} torr. With this pressure in the gas gap, the heat switch has a thermal conductance of approximately 100 mW/K. Thus, the on/off ratio of the switch is approximately 10,000.

e. Features for Laboratory Testing:

It should be emphasized that the GSFC refrigerator is a development model. As such, it will be extensively instrumented. Specifically, heaters and calibrated resistance thermometers will be placed on strategic locations throughout the ADR. This instrumentation will provide access to sufficient experimental data to thoroughly analyze the performance of the refrigerator.

To provide a convenient and flexible method of simulating space pumped helium, a continuous fill He^4 refrigerator has been included in the test cryostat. This refrigerator would not, of course, be part of the flight model ADR.

f. Impact of New Requirements on the Design:

As indicated earlier, to provide cooling power for bolometers in a Shuttle launch experiment, an ADR must satisfy several new requirements. The impact of these requirements on the design of the ADR can be seen in the preceding design summary. In particular, the most important of these impacts are the following:

- To survive the Shuttle launch, the ADR must have a strong and rigid support system. The dominant heat load on the ADR is the heat conducted through this support structure.
- To operate with the liquid helium at 1.5 K to 2.0 K requires a heat switch capable of functioning at higher temperatures than is possible with the standard superconducting heat switch. This requirement necessitated the design of a getter operated gas gap heat switch.
- To produce a minimum heat leak on the stored cryogen, the efficiency of the ADR has been maximized. To achieve this efficiency, the thermal paths within the refrigerator were designed with great care.
- To obtain a 90% duty cycle, severe constraints were placed on the physical construction of the ADR. Specifically, the rapid magnetization and demagnetization will create excessive eddy current heating in any large piece of highly conductive metal within the field. This requirement resulted in the use of fine copper wires for thermal conductance.
- To satisfy the temperature stability requirements, the cylindrical paramagnetic salt "pill" was designed for higher internal thermal conductance. In addition, the programmable power supply was servocontrolled to produce an isothermal demagnetization.
- To ensure that the superconducting magnet could be easily space qualified, the ADR was designed to use a limited magnetic field.

MODIFICATIONS REQUIRED FOR A FLIGHT MODEL ADR

Due to the relatively large costs associated with them, several requirements for a flight model ADR are not incorporated in the engineering model. These include flight qualified electronics, a space qualified superconducting magnet, an automated operating system, and elimination of fringing magnetic fields at the bolometers. Each of these areas have been or will be addressed by various programs both in and outside NASA.

Electronic systems not presently qualified for space include the electronics associated with high sensitivity resistance thermometry and the superconducting magnet charging system. Excellent temperature sensitivity could be obtained by using a non-observing bolometer as a resistance thermometer. The electronics associated with this bolometer could be essentially identical to the electronics associated with the observing bolometers. Bolometers and their associated electronics have been flown on a number of balloon experiments, and space qualified bolometers and the associated electronics are presently being developed for the Cosmic Background Explorer satellite.

Space qualification of a superconducting magnet charging system for an ADR should not be a difficult undertaking. Magnet charging systems with very simple circuit designs have been flown on a number of balloon flights. Furthermore, the magnets flown on these balloon programs required over 100 amps to charge them. The magnet for a space qualified ADR would require only a fraction of this current. It should also be mentioned that the total energy required to charge the magnet is very small, namely 10,500 J (about 3 watt hours). The superconducting magnet must also be qualified for use in space. Primarily, this requires that it must withstand Shuttle loads (but it does not need to be magnetized during launch). It is also highly desirable that the magnet be able to operate without being submerged in liquid helium to alleviate 0-g fluid management problems. The first of these requirements is almost no requirement at all, for any well constructed laboratory superconducting magnet will survive the Shuttle loads. As for the second requirement, small modern magnets similar to those required by ADRs are often potted in epoxy. These magnets do not utilize direct contact to liquid helium to provide cooling. Several potted magnets have even been operated in a vacuum. For example, Johnson Space Flight Center used a superconducting magnet operated in a vacuum to study the moon rocks. Finally, it should be mentioned that there are proposals to fly two large (770 kg) superconducting magnets on the Shuttle for a cosmic ray experiment. If these magnets were to fly and perform well, it would certainly end any doubts about the appropriateness of flying the much smaller magnet required by an ADR.

Before leaving this discussion of the superconducting magnet, another requirement resulting from the need to conserve the stored liquid helium should be addressed. The magnet leads used to charge and discharge the superconducting magnet must pass from the electronics at room temperature to the magnet at roughly 2 K. Since a solid copper wire large enough to carry the current required by a typical superconducting magnet would conduct too much heat from room temperature to the liquid helium, special vapor cooled leads have been developed by the commercial superconducting magnet manufacturers. For example, American Magnetics, who supplied the

magnet for the GSFC refrigerator, also provided 50 amp vapor cooled leads that consume only 0.14 liters/hour of liquid helium. This is equivalent to 3.36 liters/day, which is an appreciable but acceptable boil-off rate for the shuttle sortie mission. However, this boil-off rate can easily be reduced as follows. Any reasonable sized liquid helium storage dewar that would be launched on the Shuttle will have a boil-off rate roughly 1 liter/day or more. Some of the cooling power of this boil-off can be used to decrease the heat load due to the magnet leads by routing the leads through the dewar wall inside the vent line. Even more important the boil-off rate can be greatly reduced by designing, a magnet to draw much less current than that used in the present GSFC refrigerator. This would be accomplished by simply using small diameter superconducting wire. A magnet using only 4 amps could be constructed, reducing the heat load on the cryogen from the magnet leads by a factor of 150.

Another feature of a flight model ADR not presently incorporated into the GSFC refrigerator is automated operation. But, a microprocessor controller for an ADR has been developed by J.P. Eisenstein et al² and is presently in use at the University of California, Berkeley. This controller appears to be quite similar to that needed for a flight model ADR.

It would be essential that a flight model ADR not produce any appreciable magnetic field at the bolometers since the magnetoresistance of the bolometers might interfere with their operation. These fields can be eliminated by any combination of the following techniques. First, a superconducting "bucking" coil could be put in series with the demagnetization magnet and positioned so as to cancel the fringing magnetic field of the demagnetization magnet in the region of the bolometers. Second, a superconducting shield could be put around the bolometers. And finally, the bolometers could be physically separated from the demagnetization magnet to reduce the fringing fields at their location. Using these three techniques in concert will virtually eliminate the magnetic field in the region of the bolometers.

CURRENT STATUS

The design and fabrication of the GSFC refrigerator has been completed. The test dewar and the superconducting magnet and its support structure have been designed, fabricated, and delivered to the GSFC. The electronics to control the demagnetization have been designed and assembled. Final assembly and testing of the refrigerator is in process.

Preliminary tests of the adiabatic demagnetization refrigerator have been completed. While quantitative measurements of performance have not yet been performed, some qualitative statements can be made. The cooling power of the salt pill is approximately as described here. The thermal conductance between the detector mount and the salt pill is excellent, as is the thermal conductance between the salt pill and the gas gap heat switch. In its conducting state, the heat switch has a thermal conductance of roughly half the design goal of 100 m W/K. However, this conductance is sufficiently high to allow the salt to be magnetized in 3 minutes with minimum thermal losses. The design requirement for the system was for a 5 minute magnetization. In the isolating state the thermal conductance of the heat switch is so small that a good determination of its thermal conductivity is somewhat difficult. However, the on/off ratio appears to be in excess of 10,000.

The only difficulty encountered to date is an anomalously long time constant for the gas gap heat switch when going from the conducting state to the nonconducting state. The cause of this long time constant is presently being investigated.

CONCLUSION

The detailed design of the engineering model refrigerator has not uncovered any potential problem areas that might prevent an ADR from being used in space. When and if this design is proven by laboratory testing of the refrigerator, we will have come a long way toward a flight model ADR, for this refrigerator incorporates most of the features that are necessary for a flight model. (The cold section of the engineering model incorporates all the features that are necessary for the flight model.) Features necessary for the flight model that, due to cost limitations, have not been incorporated into the engineering model either have been developed elsewhere or appear likely to be developed in the near future.

Improved bolometers are presently under development at the GSFC and other locations. These advanced bolometers, together with the adiabatic demagnetization refrigerator, will provide astronomers with a powerful long wavelength detector system.

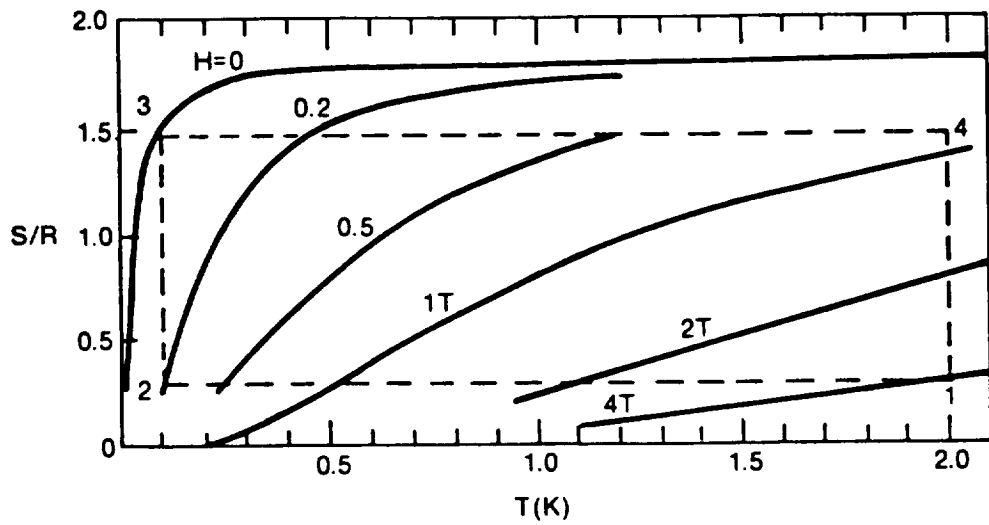

FIGURE 1a.

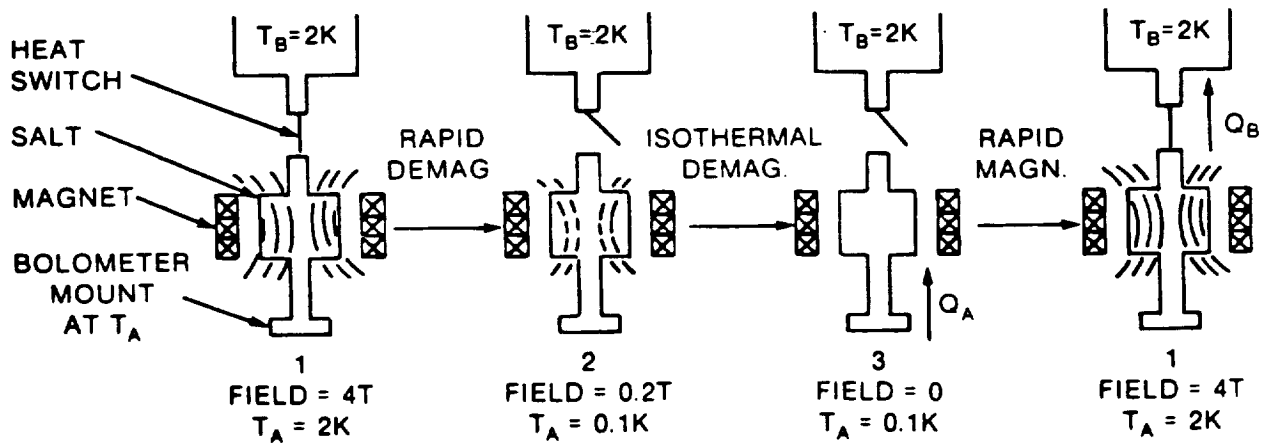

FIGURE 1b.

Figure 1. Ideal Adiabatic Demagnetization Cycle.
Numerical Parameters are for Ferric Ammonium Sulfate.

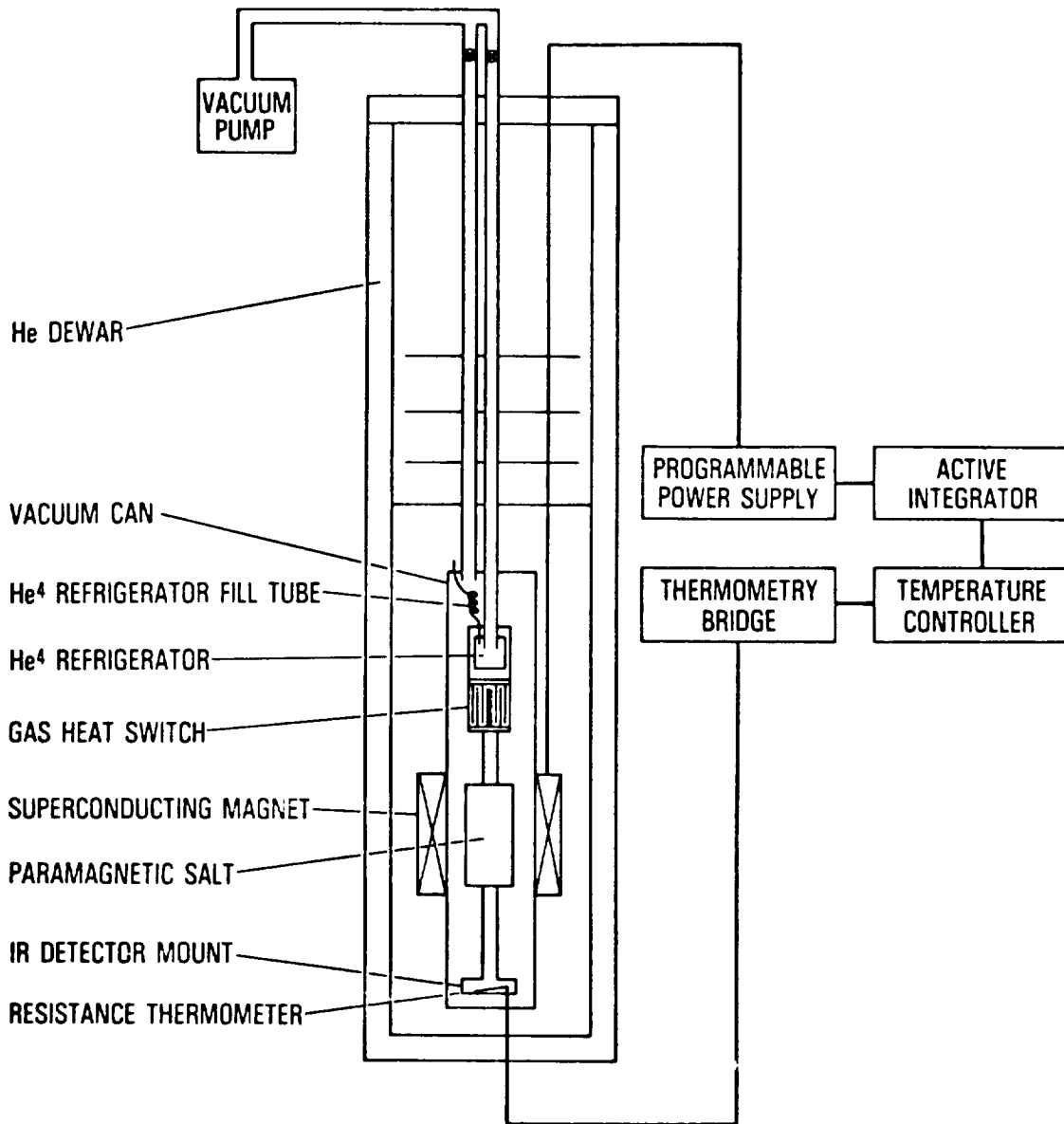

Figure 2. GSFC Adiabatic Demagnetization Refrigerator

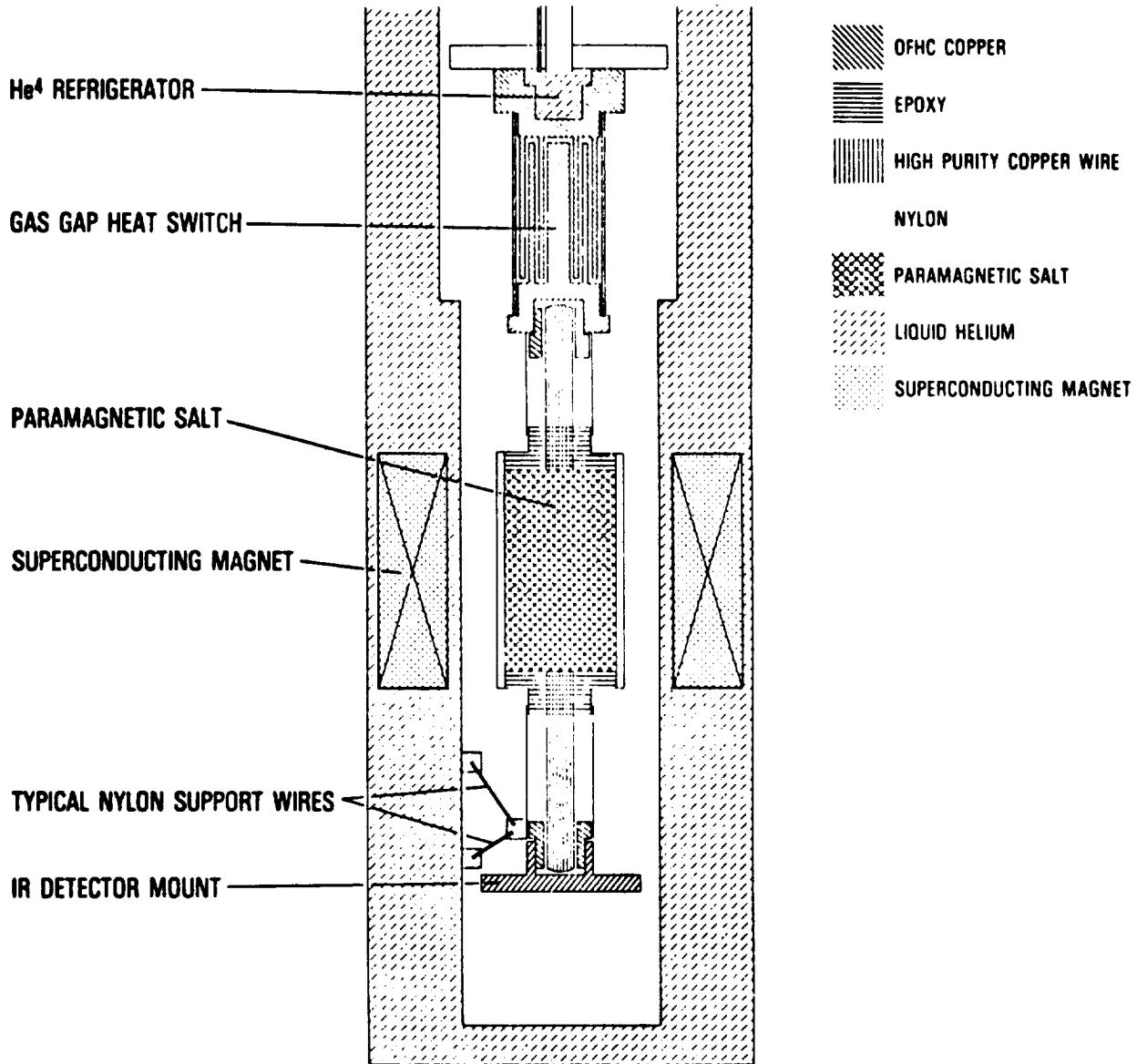

Figure 3. GSFC Adiabatic Demagnetization Refrigerator