

COMPACT CLAUDE CYCLE REFRIGERATOR FOR LABORATORY USE

Y. Hiresaki, M. Kaneko, T. Munekata and Y. Baba
Cryogenic Department, Suzuki Shokan Co., Ltd.

Y. Matsubara and K. Yasukochi
Atomic Energy Research Institute, Nihon University

ABSTRACT

A Claude cycle refrigerator with a three stage reciprocating expansion engine is described. Instead of a cam mechanism, valves are driven directly by magnetic solenoids operated by means of a micro processor control system. A swash plate mechanism is used to convert reciprocating motion of the expander pistons to rotary motion. A refrigeration capacity of 8 watts was achieved at 4.5 K with the operating pressure of 1.1 MPa and flow rate of 2.4 g/sec..

An effect of overintake operation was studied. Experimental results show that the efficiency of the expander has a peak point in the region of overintake operation with constant cycle speed, which agrees with theoretical results. The electrically controlled valve system is useful to vary the valve timing to achieve an optimum condition of operation.

INTRODUCTION

Recently the demand for a compact helium refrigerator has been increased due to the development of applications of small scale superconducting technology such as NMR for medical applications, magnetically levitated trains, and Josephson-Junction computers.

In our previous theoretical study of the multi-stage Claude cycle helium refrigerator it was predicted that the existing optimum value of working pressure is lower than for commercial machines (1). To operate efficiently at low working pressure, such as below 1.0 MPa, three expanders are needed. This is shown in another study that the efficiency of a refrigerator increases by increasing the number of expanders while decreasing the operating pressure (2).

Simple mechanical design is an important factor for the three-stage Claude cycle refrigerator with three reciprocating expanders having six valves. Electronic control techniques are a powerful method to simplify the mechanical design. A micro processor control system provides not only a simple mechanism but also a flexible system such as variable valve timing

control system or variable cycle speed control system.

OUTLINE OF DESIGN

Figure 1 shows the main unit of the refrigerator without heat exchangers. The magnetic solenoid assembly with actuating valve rods is placed on the upper flange. The swash plate mounted in the crosshead housing is used to convert reciprocating motion to rotary motion. Rotary motion of the swash plate is transmitted to a DC brake motor working as an electric generator by the V belt. Speed of revolution of the brake motor is maintained at a constant value by the speed control circuit. The DC motor works in its usual motor mode at starting time. Heat exchangers are of coiled finned tube using soldered copper finned tube. The cold box has a diameter of 40 cm and length of 1 m.

The electrical control system includes two micro processors, the valve driving circuit, the speed control circuit, the interface circuit to measure temperature and pressure and another interface circuits. The system is controlled by a host computer via a standard communication line.

The compressor₃ for a commercial model has an input power of 7.5 kW and a capacity of 52 Nm³/hour with 1.05 MPa.

EXPANDER AND SWASH PLATE

The expansion engine has three identical cylinders with a bore of 50 mm, which are arranged symmetrically above the swash plate. Reinforced phenolic pistons are sealed by capseals at their warm end of them. A stroke of a piston is 30 mm. Fig. 2 shows a scheme of the expansion engine, representing the bottom part of the cylinder and piston, the swash plate and the flywheel which also serves as a pulley. The swash plate is lubricated by oil and connected to the rotary encoder not shown in the figure.

VALVE MECHANISM

The valves of the expansion engine are driven directly by DC solenoid coils which are actuated by the micro processor instead of the usual cam mechanism. The rotary encoder connected to the axis of the swash plate is an absolute value type encoder of which the output signal represents a three digit number corresponding to the angle of the axis. At every one degree of angle the encoder sends interrupt signal to the micro processor. The processor has a table in the memory containing values of the angle corresponding to the setting points of the valves. Comparing the angle obtained from the rotary encoder with the table, the processor operates valves through the driving circuit. This system responds with a resolution of 1 degree for engine speeds up to 350 rpm. The absolute value type

rotary encoder makes the system simple in comparison with the incremental type. Since set points of valves can be changed by changing the content of the table, valve timing can be changed even during operation.

Fig. 3 shows typical data of valve action recorded by an electromagnetic oscillograph along with data of the voltage across the solenoid coil and the signal of the angle marker. The upper level corresponds to a closed state of the valve. The osciration which appears during the rising and falling periods is due to a characteristic of the transducer. Time delay during closing is 10 to 20 m sec..

ELECTRICAL CONTROL SYSTEM

Fig. 4 shows the block diagram of the electrical control system for test operation of the prototype. The micro processor operates six valves on three expanders. The cycle speed of the expansion engine is varied by control of the DC brake motor. The speed control circuit compares the reference voltage with the output voltage from the tachometer on the brake motor, and maintains constant cycle speed by means of changing the electrical load of the brake motor. A PDP11/V03 was used as a host computer and also as a data acquisition system.

Fig. 5 shows the block diagram of the commercial model which includes another micro processor CPU-1. CPU-1 receives commands from the host computer through a standard communication line, RS-232C, or an IEEE-488 bus. Main roles of the CPU-1 are

1. setting the cycle speed on the speed control circuit
2. changing the valve timing
3. monitoring temperature and pressure
4. operating the J-T valve and other valves
5. operating the compressor unit
6. performing emergent sequence
7. sending back infomation about the status of the refrigerator to the host computer.

The host computer contains an operator console and can be interconnected to another computer system. In addition to using the computer for these functions the user may also make other programs such as a time schedule or a data logging program on the host computer. This system is useful in both laboratory and industrial applications.

TEST RESULTS AND DISCUSSION

Fig. 6 shows typical experimental results of the test operation with 0.8 MPa pressure at the inlet of third expander. Refrigeration capacity of 8 watts at 4.5 K was obtained at 74 rpm and 2.4 g/sec. total mass flow rate. Expander efficiencies of 60, 70 and 74 % were obtained at inlet temperature of 129, 48, and 13 K respectively. Ideal isothermal compressor

work at 290 K is 3.5 KW, when the helium gas is compressed from 0.1 MPa to 1.1 MPa with a flow rate of 2.4 g/sec., therefore the actual input power will be less than 7 KW with the assumption that the overall efficiency of the compressor is more than 50 %. With this assumption the ratio of the refrigeration capacity to the input power is 1.1×10^{-3} .

Fig. 7 shows the efficiency of the third expander against the filling factor, X, with constant cycle speeds of 140 rpm and 180 rpm. Inlet temperature of the expander is 15 K and inlet and outlet pressure are 0.8 and 0.12 MPa respectively. Each curve has a remarkable peak in the overintake region, $0.34 < X < 1.0$. Fig. 8 shows theoretical results with same condition as the experiment for three different values of heat leak to the expander. The model for the calculation (3) is illustrated in Fig. 9 on a T-S plane. Helium gas at high pressure, point i, is expanded isentropically to point f. Heat leak is considered only on the process from f to ff and gas expands to pressure state Pe. The final state e is reached by the remaining gas at point el and leaving gas at point e2. In spite of the simplicity of this model, the theoretical results agree well with experimental results.

Fig. 10 shows cool down curves for each expander on the normal and the overintake mode. On the overintake mode at 165 rpm the cool down time is 4.5 hours compared to 6 hours in the normal mode at 140 rpm. Improvement of operation in the overintake mode is clear even though there is a difference of speed between them.

SUMMARY

A compact three stage Claude cycle helium refrigerator which produces 8 watts of refrigeration at 4.5 K has been made. The electrical control system with micro processors provides a flexible system which permits the operating mode to be changed, and is useful to simplify the valve mechanism. Overintake operation increases refrigeration capacity without decreasing the efficiency of the expanders.

REFERENCES

1. Matsubara, Y., Kaneko, M., Hiresaki, Y., and Yasukochi, K.: "Exergetic Analysis of Multi-staged Claude Cycle Helium Refrigerator", Cryogenic Processes and Equipment in Energy System, 131-134, ASME, Century 2 Publication, 1980.
2. Khalil, A. and McIntosh, G.: "Thermodynamic Optimization Study of the Helium Multi-engine Claude Refrigeration Cycle", Adv. Cry. Eng., vol. 23, 431-437, 1978.
3. Kaneko, M., Hiresaki, Y., Matsubara, Y., and Yasukochi, K.: "Performance of Reciprocating Expansion Engine with Electronic Control Valves", Proceedings of the 9'th Int'l Cryog. Eng. Conf., 355-358, 1982.

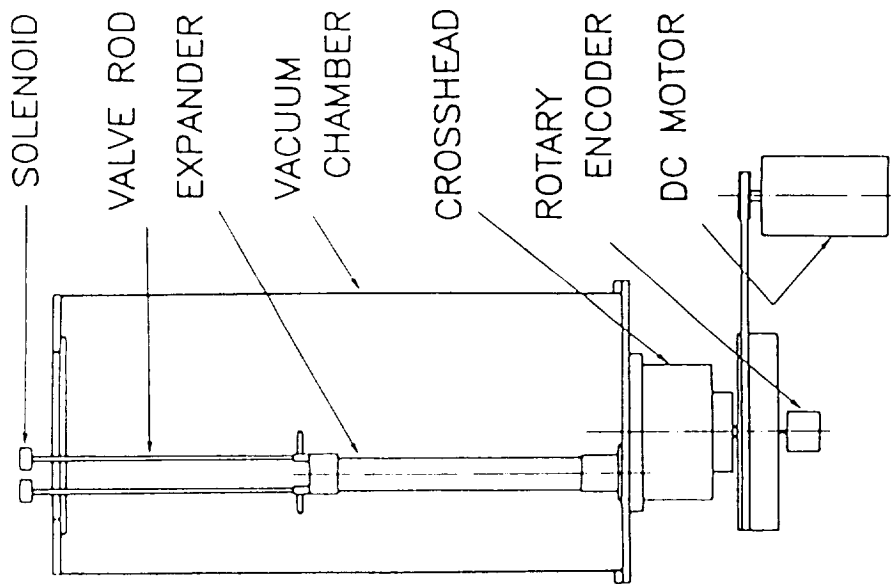

Fig. 1 Schematics of the expansion engine

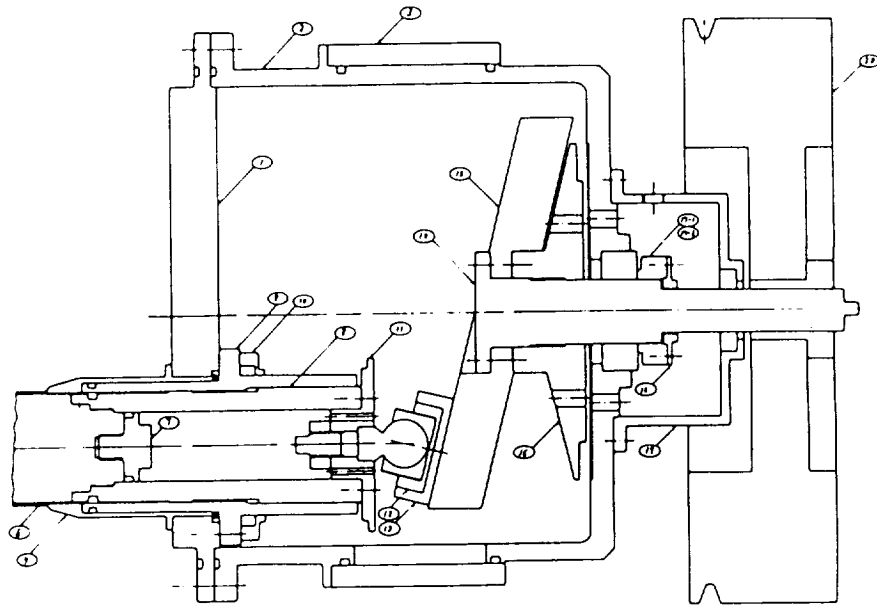

Fig. 2 Bottom end of the expansion engine and the swash plate mechanism.

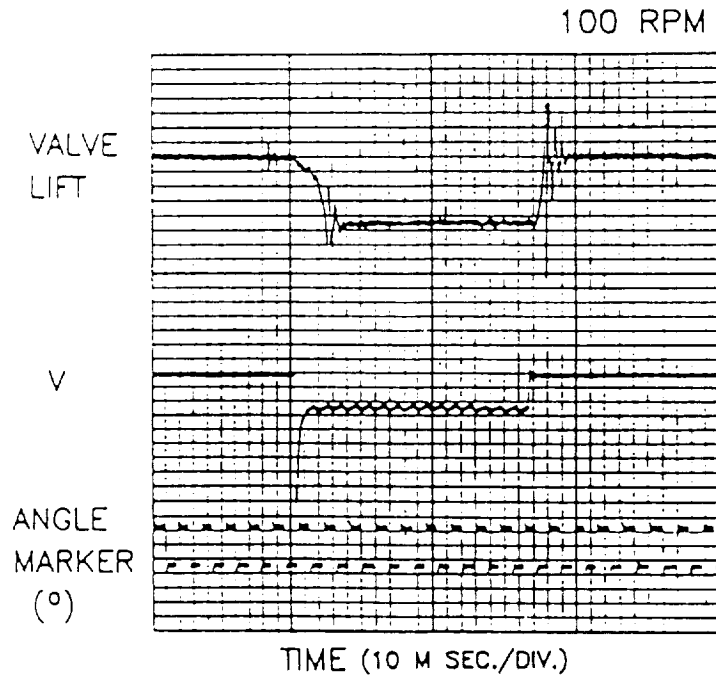

Fig. 3 Valve action compared with voltage V across a solenoid coil. One cycle of the marker corresponds to 10 degree of angle.

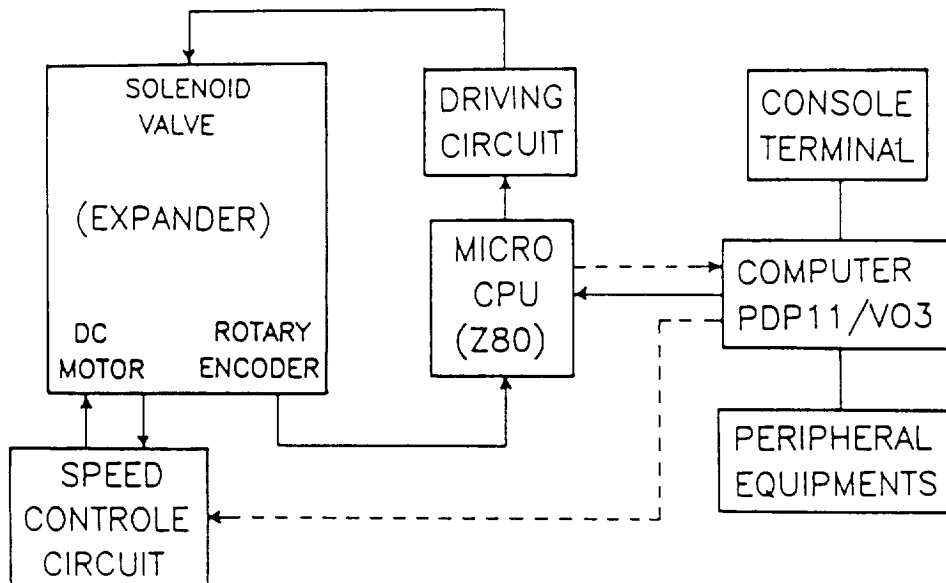

Fig. 4 Block diagram of the control system for experiments.

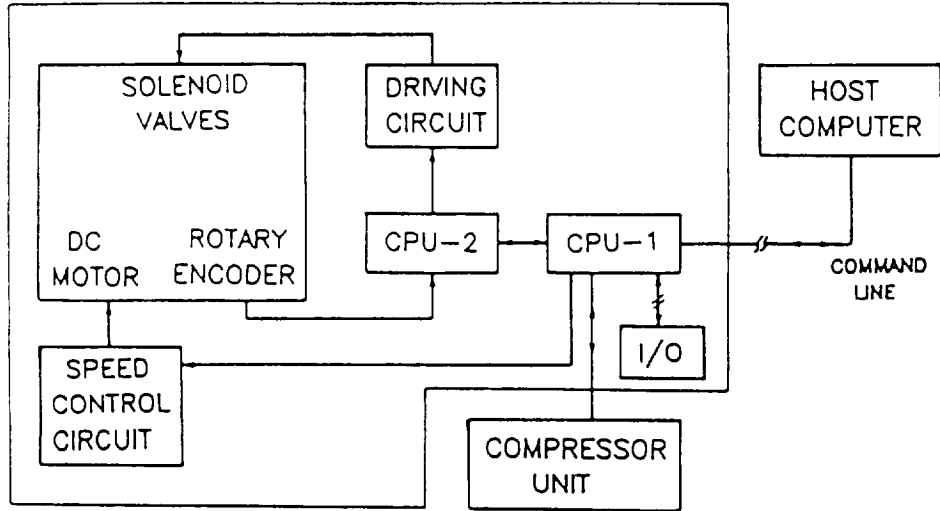

Fig. 5 Block diagram of the control system of the commercial model.

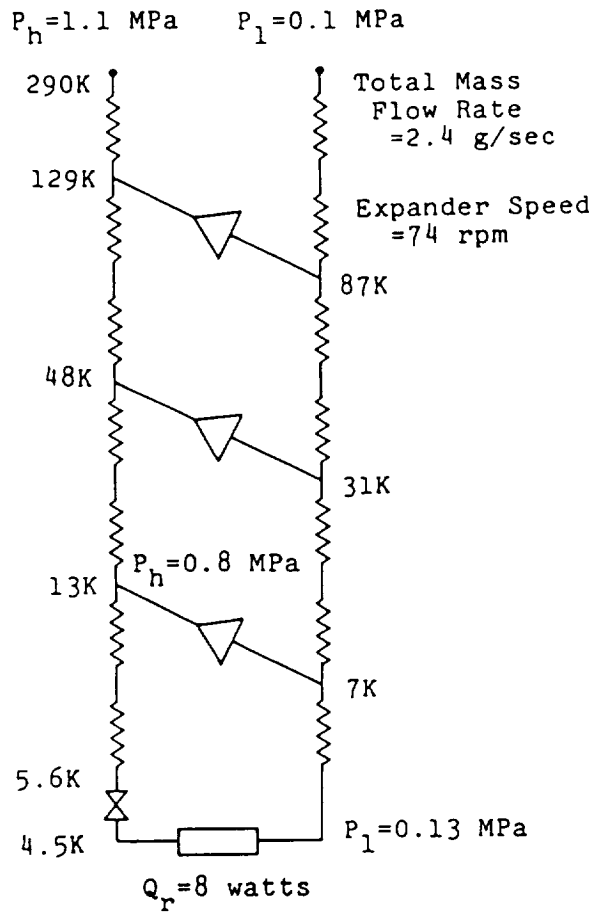

Fig. 6 Typical result of a test operation.

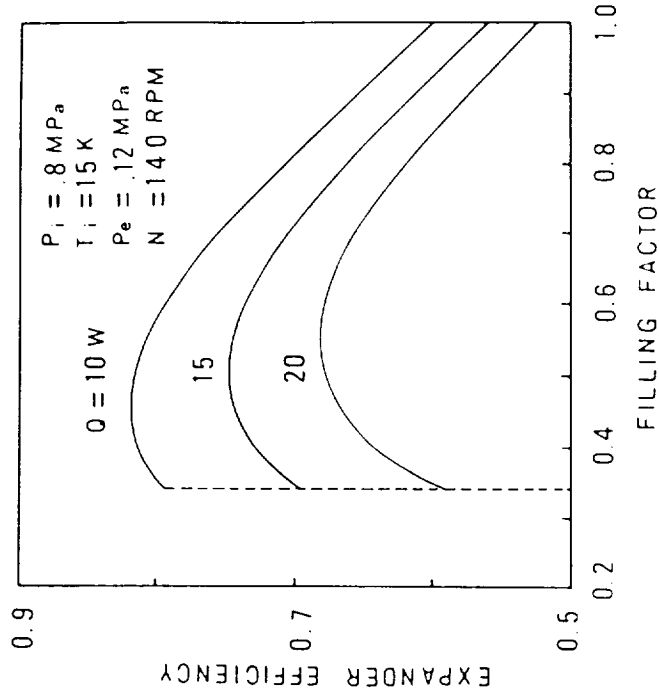

Fig. 8 Efficiency of the expansion engine against the filling factor (Theoretical results).

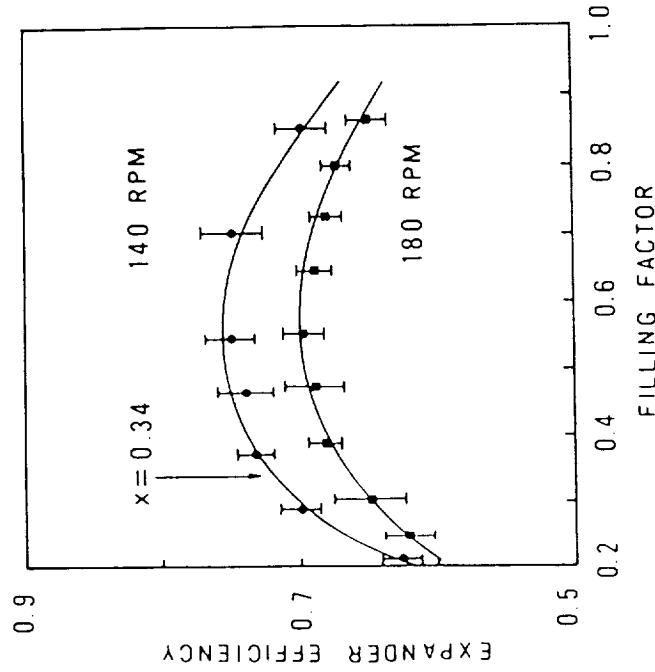

Fig. 7 Efficiency of the expansion engine against the filling factor X (Experimental results). Inlet temperature = 15 K Pressure = 0.8 MPa.

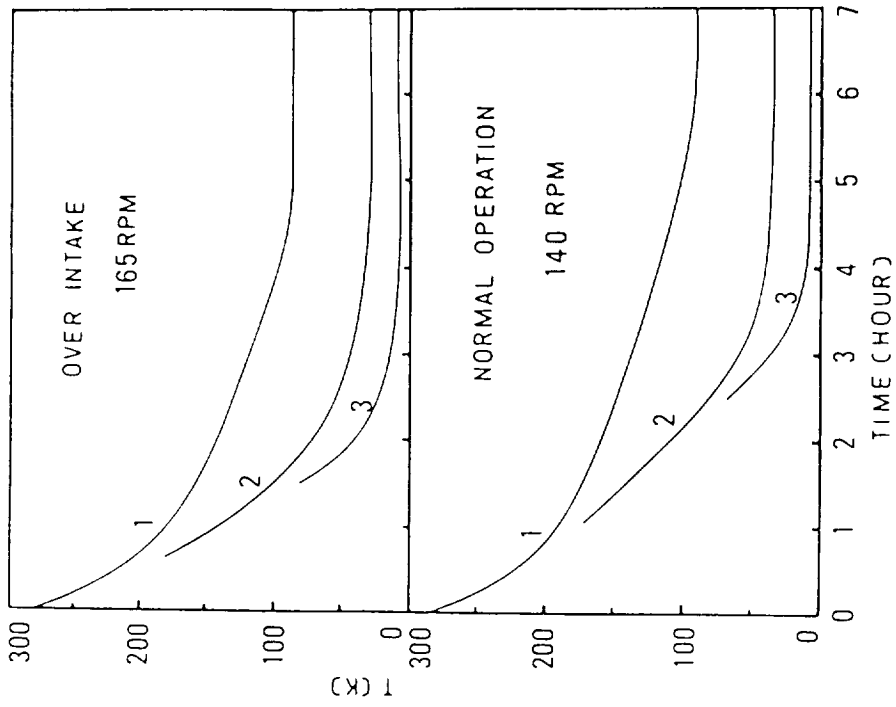

Fig. 10 Cool down characteristics for expanders.

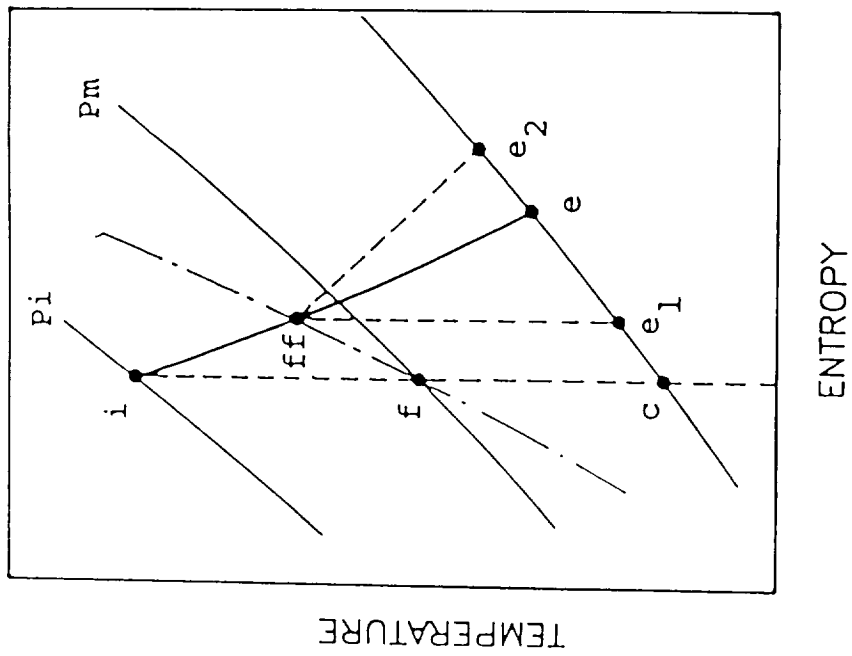

Fig. 9 Model of the expansion process on a T-S plane.