

N84 1000 0

## PRIMARY ELECTRIC POWER GENERATION SYSTEMS FOR ADVANCED-TECHNOLOGY ENGINES

Michael J. Cronin  
Lockheed-California Company  
Burbank, California 91503

Although enthusiasm for the all-electric airplane is waning and current projections are that it will not be a reality until the 1990's, I feel that we can have an all-electric airplane by 1985. The variable-frequency, variable-voltage power system is a very efficacious system for an all-electric airplane.

An advanced-technology engine (fig. 1) is exemplified by a high bypass ratio and a high compression ratio resulting in a low core airflow. Taking bleed from the core flow upsets the aerothermodynamic cycle of the engine and is a problem for the engine designer. As the discharge section gets smaller, there is a point at which the physical installation of the same size bleed ducts into that small core section becomes a problem. Then a splitter must be used to bring the hot ducts through the engine case into the pylon. That splitter is in the bypass airflow.

The all-electric engine would not have these problems. Elimination of the bleed-core hardware, the blowout doors, and some of the transverse-thrust loads are further synergistic weight and cost benefits that derive from the all-electric airplane.

Figure 2 shows cruise specific fuel consumption (sfc) as a function of bypass ratio. With no secondary power extraction, specific fuel consumption decreases with increasing bypass ratio. Engines using conventional power extraction are limited in bypass ratio to some lower value. The all-electric can use a higher bypass ratio and thereby gets the benefit of a reduced sfc. Figure 3 shows very simply that bleed air does cost fuel and decrease energy efficiency.

Figure 4 shows that for a Pratt & Whitney energy-efficient engine (E<sup>3</sup>) a 2.2-lb/sec bleed increases sfc by 4.7 percent (refer to 70-percent power line). That 2.2-lb/sec bleed is equivalent to about 220 hp. Plotting mechanical power extraction versus  $\Delta$ sfc shows an increase of only 1.3 percent in sfc for 220 hp. (This is a representative horsepower for an electric-driven environmental control system (ECS).) This comparison is the basis for saying that mechanical power extraction is much more efficient than bleed power extraction.

Engine sizing effects for a twin-engine, 150-passenger airplane with a conventional bleed system, a 50-percent recirculation system, an electric ECS with bleed deicing, or an all-electric system are compared in table I. With one engine out during a 22 000-ft hold (table IA), 53 percent of the core flow would be demanded by bleed in the conventional system. Even with 50-percent recirculation, ECS bleed would still constitute 39 percent of the core flow. Of course, with the all-electric system there would be no effect at all on the core flow. For an airplane with advanced ECS bleed and with one engine out during icing at maximum climb power at 20 000 ft and a Mach number of 0.65, there is a 12.8 percent loss of net thrust on the remaining engine, due to bleed. The change in fan diameter to compensate for this thrust loss is about 4.6 in. For the all-electric airplane the net thrust loss is only 2.6 percent, and the fan diameter change to compensate is about 1 in. For the constant-inlet diameter, constant-thrust case the turbine inlet temperature for the bleed system would increase 113 deg F, as compared with 16 deg F for the all-electric system. That is a large increase for the General Electric engine.

The weight increase for the bleed system would be 16.2 percent.

Another aspect is the temperature margin for the engine with one engine out (fig. 5). Clearly the margin between the turbine inlet temperatures for maximum climb and takeoff is much narrower for the E<sup>3</sup> engines than for the CF6 and other current engines. Therefore a 113 deg F rise, as shown on table I really overheats the engine. A 16 deg F rise is well within the lower band in figure 5.

Finally, there is the question of what is done with the bleed air after it is tapped. Because it is at such a high temperature during takeoff, we invariably have to consider a precooler (fig. 6). The precooler needs bypass fan air to pass through it in order to reduce the temperature of the air entering through the pylon. The ducting, valves, precoolers, pneumatic starter, and the ballooning of the nacelle (caused by placing pneumatic starters at, say, the 6 o'clock position) are all eliminated in the all-electric system.

The engine manufacturer must be concerned about the stability margins on the engine; that is, the difference between the steady-state operating line and the surge line. He must preserve this margin for throttle chops and throttle bursts and different altitudes. A typical compressor map is shown in figure 7. The one favorable aspect of bleed is that it tends to raise the surge line and drop the operating line. So bleed does increase the stability margin. Horsepower extraction raises the steady-state operating line and thereby reduces the stability margin. Neither Pratt & Whitney nor General Electric think that this is any problem, particularly when they know what the horsepower extractions will be.

In the all-electric airplane the generator is the sole source of electric power; it powers the primary and secondary flight controls, the environmentals, and the landing gear. It eliminates the need for bleed air, the high-pressure hydraulic system, and the pneumatic system. To accomplish this may require large generators in the 300- to 500-kVA class.

There are five candidates for all-electric power systems: the advanced constant-speed drive (CSD); the variable-speed, constant-frequency (VSCF) system; the VSCF:dc link; the 270-V dc system; and the direct-driven generator system. All of these systems, except the last, have been developed.

Figure 8 shows diagrams of these power generation systems. The conventional CSD system takes the variable input speed of the engine and gives a constant output speed to the generator. The generator can be optimally designed since it is driven at a constant speed. With a constant-voltage, constant-frequency (CVCF) bus some of the generator output can be converted to 270 V dc for flight controls and some can be converted to 28 V dc.

In the VSCF cycloconverter system the CVCF bus is obtained electrically. The generator must be designed to operate over the engine's speed range. Some of the output can be converted to 270 V dc and 28 V dc just as in the previous system. The VSCF:dc link approach is similar to the cycloconverter system except the power is rectified and inverted to obtain the CVCF bus. In the 270-V dc system all of the power is rectified and distributed on a dc bus. To obtain other voltage levels or ac, the power must be inverted. In the direct-drive system, as much of the power as possible is used in the variable-voltage, variable-frequency (VVVF) form. This eliminates the need to condition or regulate the power. The other types of power required, such as 400 Hz, 270 V dc, and 28 V dc are provided on a dedicated basis.

Figure 9 shows the effect of speed on power output. The power output of any rotating piece of machinery is proportional to its speed. Hydraulic and constant-displacement pumps have output proportional to speed; centrifugal pumps have output that is a cubic function of speed. Centrifugal compressors

and positive-displacement compressors like the Heli-rotor have variable-rate output, either a cubic function or linear. Piston engines have always had power output proportional to their speed, and turbine engines have power output that is a much stronger function of speed. Motors and generators are no different. The motor and generator want to produce power that is proportional to their speed. It is an unnatural function for a piston engine to put out, say, its maximum horsepower when it is idling. Everything has a speed function. A motor-generator system can be made to produce constant power as a function of speed. However, when that is done, the machines must be sized for rated power at minimum speed. As a result, the machines are oversized for any other operating speed. Providing constant power as a function of engine speed in an aircraft power system also results in oversized machines as shown in figure 10. The CSD, VSCF, and 270-V dc systems all have twice the power capability required by the mission. The crosshatched areas in those plots represent wasted power-producing capability and as a result, a weight penalty.

The VVVF system is sized for the mission; therefore it has no excess power-producing capability. There are many large loads in flight (e.g., galley and deicing) that are not present on the ground. As a result the power requirements are less and can be made to match the output at the engine's 50-percent idle speed.

Another factor in the comparison of these systems is shown in figure 11. The power flow in the CSD, VSCF, and 270-V dc systems passes through two devices; but in the VVVF system it passes through only one. As a result, the first three systems have added complexity, inefficiency, and weight to contend with. This is in addition to the larger generators required by the VSCF and 270-V dc systems.

In the transmission of power (fig. 12) the conventional system requires the use of larger gages. After transmitting 40 kVA for 75 ft, a gage change is necessary, and this increases weight. For the 200-V dc system there is some improvement and even more for the 230/400-V system and the 400-V dc system. Therefore the use of higher voltage must be considered. In the study done for NASA Johnson Space Center, Lockheed selected a 230/400-V ac system as the primary power system and doubled the frequency.

Figure 13 shows the magnetic weight of a system as a function of frequency. When the British and American advisory staffs were evaluating power systems for world-wide standardization, it took a lot of time to settle on the 400-Hz system. At one point 250-Hz systems were considered. They gave motor speeds of 24 000 rpm, which was thought to be reasonable, and the voltage level was assumed to be reasonable at that time. Now we should look at some higher frequencies. And again in the NASA Johnson study, Lockheed chose 800 Hz. An 800-Hz system would reduce electromagnetic weight about another 30 percent. That looked like a good compromise. It also permitted a 48 000-rpm maximum motor speed.

We must be careful not to denigrate variable-voltage, variable-frequency systems in an off-handed way. They are the electrical engineer's choice for motors and for many loads in the airplane. Use of VVVF systems does not abrogate use of other high-technology systems, such as advanced CSD, VSCF, or dc-link. All are used in the hybrid system. It is only a matter of how much of each of these systems is used. We want to use as much power in the VVVF form as possible. Motors and electronics can operate over a wide range of voltage and frequency with no prospect of damage if the voltage-frequency ratio (V/F) is kept constant. Sixty-Hz power can be used in 400-Hz transformers if the V/F is maintained. Even an 800-Hz system is compatible with a three-phase 200-V, 400-Hz system and existing ground supplies.

Figure 14 shows dedicated power sources derived from the VVVF system. Any type of dedicated power can be used in an airplane with the variable-frequency, variable-voltage power source. The link, for example, already uses the samarium-cobalt generator, which develops variable-voltage, variable-frequency power.

Variable voltage, variable frequency is the inherent form of power from a permanent-magnet (PM) generator. When wound-rotor machines were used, we had to make the regulator produce that type of power. Now the PM machine produces variable-voltage, variable-frequency power, and it is inherently suited to the aircraft load versus the engine speed profile. When an airplane is landing with a heavy deicing load on the wings or the windshield, you don't want all that heat being dissipated after landing. The power will automatically be reduced as the engine is throttled back on touchdown. The VVVF system is also an excellent power source for motors and transformers because of its constant V/F. And here is a critical point - during cruise, jet engines, and turboprop engines particularly, operate almost at constant speeds. This provides, in effect, a constant-voltage, constant-frequency system during most of the flight. We are trying to keep the transmission simple, to make the generator and the installation itself the simplest in the engine, and to improve generator and system reliability. We are going back to some very basic concepts in making the overall system extremely simple. The Navy and the Air Force complain bitterly about the decreasing availability of aircraft, and this is caused by the use of sophisticated electronics. We should take stock of the effect on aircraft availability of the choice of power system.

The features of the VVVF system are (1) kVA is proportional to speed, (2) minimum voltage regulation, (3) no frequency transients, (4) low harmonics, (5) low radiofrequency interference, (6) high transmission efficiency, (7) low weight, (8) low cost, (9) low maintenance support, (10) high reliability, and (11) high aircraft availability.

Figure 15 shows synchronous generator performance as a function of speed for the wound-rotor machine. The 400-Hz generator (120-V phase voltage and 120 kVA) designed for 12 000 rpm would lose almost all of the load very quickly below the threshold of 380 Hz. The reason is the square law effect of the integral excitor. The only way to sustain the power from that generator would be to decrease the voltage in step fashion. Although most system engineers do not realize it, a 400-Hz generator can be operated from 200 to 400 Hz if the voltage is controlled at the 50-percent voltage (60 V). But the power will not increase with speed unless the voltage is raised in step fashion.

How do we design a generator for a VVVF system? First, we recommend a higher per-unit voltage and a higher per-unit frequency. These values will depend on an analysis of the loads. High per-unit speeds are desirable. Second, we recommend a large air-gap generator (16 000, 24 000, or 48 000 rpm). The large air-gap machine would exhibit lower regulation, and we want to avoid the need for a regulator. This will minimize the voltage transients; the  $x_d$ , what we call the transient direct-axis reactance, will be lower. The voltage unbalance will be lower. The overload output will be potentially higher. A 75-kVA generator will produce as much as 700 A with this type of design. Third, we recommend moderate electric loading, or current density - about 12 000 A/in<sup>2</sup>. Oversize the conductor. There is always a balance between the copper and the iron in the machine. Lower current densities will improve efficiency because there would be lower IR drop, reduced I<sup>2</sup>R losses, and reduced unbalance. We might have to accept a slight increase in weight. And, again, let us not make a fetish of weight. The military services and the airlines would like to see a bit more reliability for a change.

Fourth, we recommend replacing high-permeability irons with Cubex, cobalt iron, silicon iron, Supermendur, or Hyperco-50. Here the desire for low weight must be balanced with acceptance of increased costs. For example, Hyperco-50 probably costs about 40 times more than a silicon iron.

Figure 16 illustrates VVVF generator regulation. We want to keep the inherent regulation of the generator small. This regulation is a function of the impedance drop, the air-gap flux density, the cross magnetomotive forces (MMF), and the load factor. We all know, from our basic training and machine design, that the reactance drop is the biggest component. It is most significant at low power factors. In other words, when the current is lagging the voltage by a large degree, IX drop has a significant effect on  $\Delta V$ . Because the VVVF tends to operate at good power factors, even though the IX may be fairly large, it has a minimal effect. The IR drop is most effective in reducing the voltage. Therefore it is necessary to keep the IR drop down to have good regulation.

Table II shows the motor loads from an airplane. There is a profusion of motor loads in a large bomber, a tactical fighter, or a troop transport, there being probably over 200 motors in an airplane. All of these loads can be operated off the VVVF generator directly by using squirrel-cage induction motors. As shown in table II, almost all of the motor loads can be powered by the variable-voltage, variable-frequency system. One load that does not appear to match the VVVF output is a fan. Normally fans are required to provide a constant airflow and therefore require a constant-frequency power source.

Figure 17 shows induction motor performance. Figure 17(a) shows what would happen if you were to use constant voltage and drop the frequency. The top curve shows the normal condition of a 400-Hz motor at 200 V, a typical torque-speed curve. At 200 Hz the constant-voltage motor is able to provide a much larger torque. But as the motor's load, for instance a compressor, decreases in speed, the torque demand is actually decreasing. A motor operating in this fashion has large amounts of excess torque. On the other hand the variable-voltage, variable-frequency system (fig. 17(b)) provides constant torque capability at any speed. As a result, the torque capability and demand are better matched.

Figure 18 is from one of the studies that AirResearch did for NASA 7 to 10 years ago. It shows the weight of, say, a 25-hp brushless dc motor versus speed. At 20 000-rpm motor speed the specific weight of the motor is about 0.78 lb/hp. This excludes the electronics because the brushless dc motor has to have electronic commutation. An induction motor at the same 20 000 rpm would only weigh 0.48 lb/hp (fig. 19), and it does not require electronic commutation. This comparison indicates a significant weight advantage for the induction motor.

Another comparison that can be made concerns power regeneration in motors under an overhauling load condition. Figure 20 illustrates the circuitry required to get power regeneration in a brushless dc motor. Figure 21 shows that no circuitry is required for regeneration with an induction motor.

In summary, Lockheed is proposing a three-phase, 400-V, 800-Hz, direct drive power system. A samarium-cobalt generator would be the primary source of power. The constant V/F makes it ideal for supplying induction motors. Use of 400 V and 800 Hz provides the following: 100-V, 400-Hz, or 270-V dc ground power at 50-percent engine speed, 48 000-rpm motor speeds, lower feeder weights, lower transformer and machine weights, and lower filter weights. The system design is extremely simple and provides output power proportional to engine speed. Constant-voltage frequency or loads can be supplied by dedicated supplies.

General Electric, working with the Air Force Aeropulsion Laboratories, developed the 150-kVA samarium-cobalt starter-generator shown in figure 22. There is no question that future generators will be large. This 150-kVA generator has quite nominally good sizes and specific weights. This generator started the RB-211 engine in 25 sec at 59° F (fig. 23). However, at -53° F the start time was longer, coming up to 6000 rpm in 90 sec.

Figure 24 shows the results of the first study Lockheed did for NASA Johnson. It indicates that a fleet of 300 all-electric airplanes, with fuel at \$1.80/gallon, operated over a 16-year period would result in a \$5.14 billion saving. When the added benefit of operating the airplane with reduced static stability is included, the total saving would be \$9 billion. People had difficulty accepting that study. Therefore Lockheed performed another study for NASA Langley that was similar to the Johnson study but added the avionics and air traffic control areas. Some of those results are shown in figure 25. With a far-term flight control system, a far-term secondary power system, and air traffic control, a total of 44 000 lb could be saved on a 350-passenger airplane. This proved that the 23 000-lb saving projected in the previous study (on a 500-passenger airplane) was conservative. With additional innovative technologies, an even bigger saving could be realized. In a 700-passenger airplane that we looked at for NASA, doing the same thing with the breakdown (fig. 26), the weight saving could be 60 000 lb, and possibly 77 000 lb, with all of the advanced technologies. Fuel savings with the 350-passenger airplane (fig. 27) is an attractive 20 percent. The payoffs of that are such that NASA and the military should be encouraged to investigate closely the benefits that are derived from the all-electric airplane in terms of fuel efficiency, as well as all the other benefits (listed in table III).

ORIGINAL PAGE 13  
OF POOR QUALITY

TABLE I. - ENGINE SIZING EFFECTS - BLEED VERSUS ELECTRIC ECS  
[Two-engine, 050-passenger airplane; 25 000-lb E<sup>3</sup> engines.]

A: CONDITION: ONE ENGINE OUT/ICING/22.K FT HOLD

	BLEED - LB/SEC			
	CONVENTIONAL	50% RECIRC	ELECTRIC ECS/ BLEED DE-ICE	ALL ELECTRIC
LB/SEC	5.5	4.3	3.1	0
% CORE FLOW	53%	39%	25%	0%

B: CONDITION: ONE ENGINE OUT/ICING/MAX CLIMB: 20K/0.65M

	ENGINE IMPACT	
	ADV ECS (BLEED)	ALL ELECTRIC
<u>CONSTANT T41</u>		
$\Delta - F_N$ (LOSS)	-12.8%	-2.6%
$\Delta D_T$	+4.6	+1.0
<u>CONSTANT THRUST</u>		
$\Delta T41$	+113°F	+16°F
$\Delta WT$	+16.2%	0

TABLE II. - ABILITY OF VVVF SYSTEM TO HANDLE MOTOR LOADS

YES   NO   IFFY			YES   NO   IFFY		
• MAIN LANDING GEAR	X		• THRUST REVERSERS	X	
• NOSE LANDING GEAR	X		• VARIABLE WING SWEEP	X	
• LG DOORS	X		• TILT TAIL	X	
• LE SLATS	X		• CANOPYS	X	
• TE FLAPS	X		• CARGO DOORS	X	
• INLET DOORS	X		• PAX DOORS	X	
• FUEL PUMPS (BOOST)	X		• FANS		X
• FUEL PUMPS (TRANS)	X		• FCS	X	X
• ENGINE FUEL PUMPS	X		• ECS	X	X
• ENGINE LUBE PUMPS	X		• MECHANICAL ACTS	X	

ORIGINAL PAGE IS  
OF POOR QUALITY

TABLE III. - BENEFITS OF ALL-ELECTRIC AIRPLANE

AIRLINES/MILITARY	AIRFRAME SUPPLIER	ENGINE SUPPLIER
<ul style="list-style-type: none"> <li>• LOWER ACQUISITION COSTS</li> <li>• LOWER DOC/FUEL COSTS</li> <li>• REDUCED MAINTENANCE/LOGISTICS</li> <li>• LOWER CAPITAL INVESTMENT</li> <li>• HIGHER PRODUCTIVITY/AVAILABILITY</li> <li>• LOWER LIFE CYCLE COSTS</li> </ul>	<ul style="list-style-type: none"> <li>• LOWER OEW/TOGW</li> <li>• IMPROVED PERFORMANCE</li> <li>• REDUCED ENGINEERING HOURS</li> <li>• REDUCED MANUFACTURING HOURS</li> <li>• SIMPLIFIED AIRCRAFT SYSTEMS</li> <li>• REDUCED SYSTEMS TESTING</li> <li>• LOWER SYSTEM/COMPONENT COSTS</li> </ul>	<ul style="list-style-type: none"> <li>• BLEED PROVISIONS ELIMINATED</li> <li>• IMPROVED SFC/PERFORMANCE</li> <li>• REDUCED WEIGHT</li> <li>• TRANSVERSE THRUST LOADS REDUCED</li> <li>• NO 'CUSTOMIZED' BLEED REQ'S</li> <li>• SIMPLIFIED POWER PLANT</li> <li>• REDUCED INSTALLATION/REMOVAL TIMES</li> </ul>

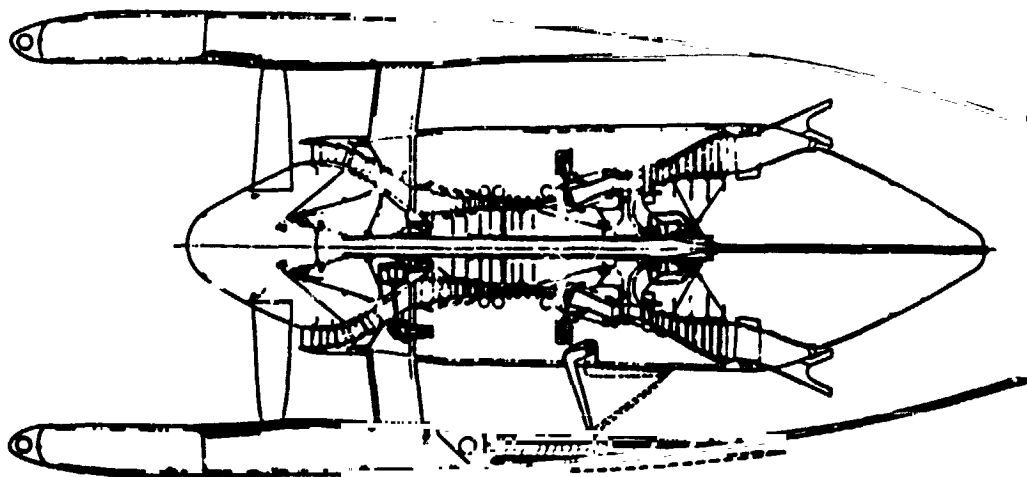

Figure 1. - Cross section of energy-efficient engine and nacelle.



ORIGINAL PAGE IS  
OF POOR QUALITY

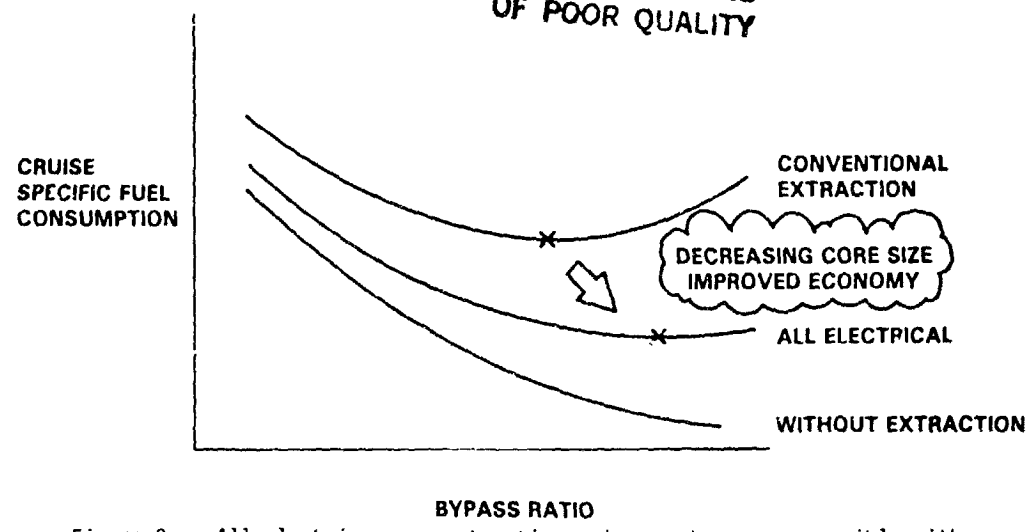

Figure 2. - All-electric power extraction - improved economy possible with new engine design.

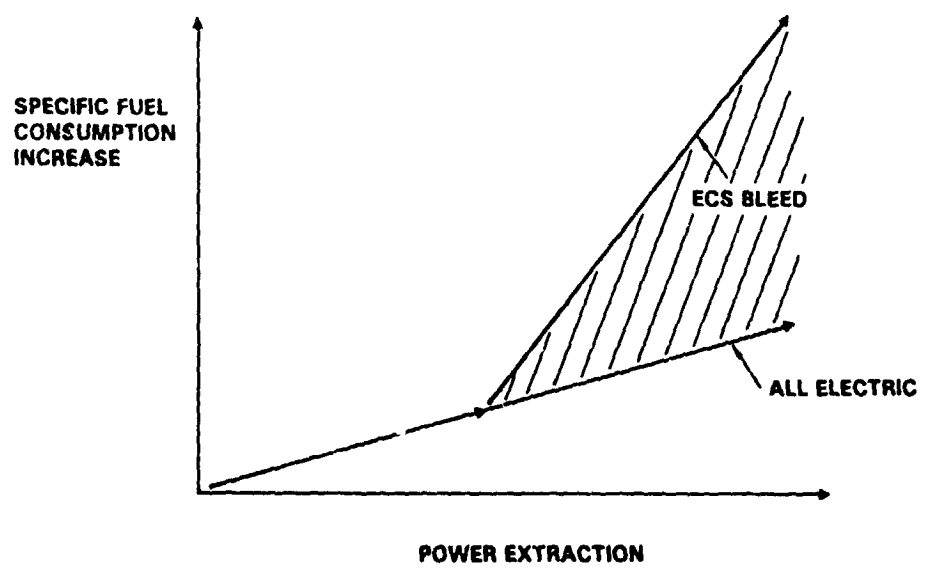

Figure 3. - All-electric power extraction - improved fuel consumption appears significant.

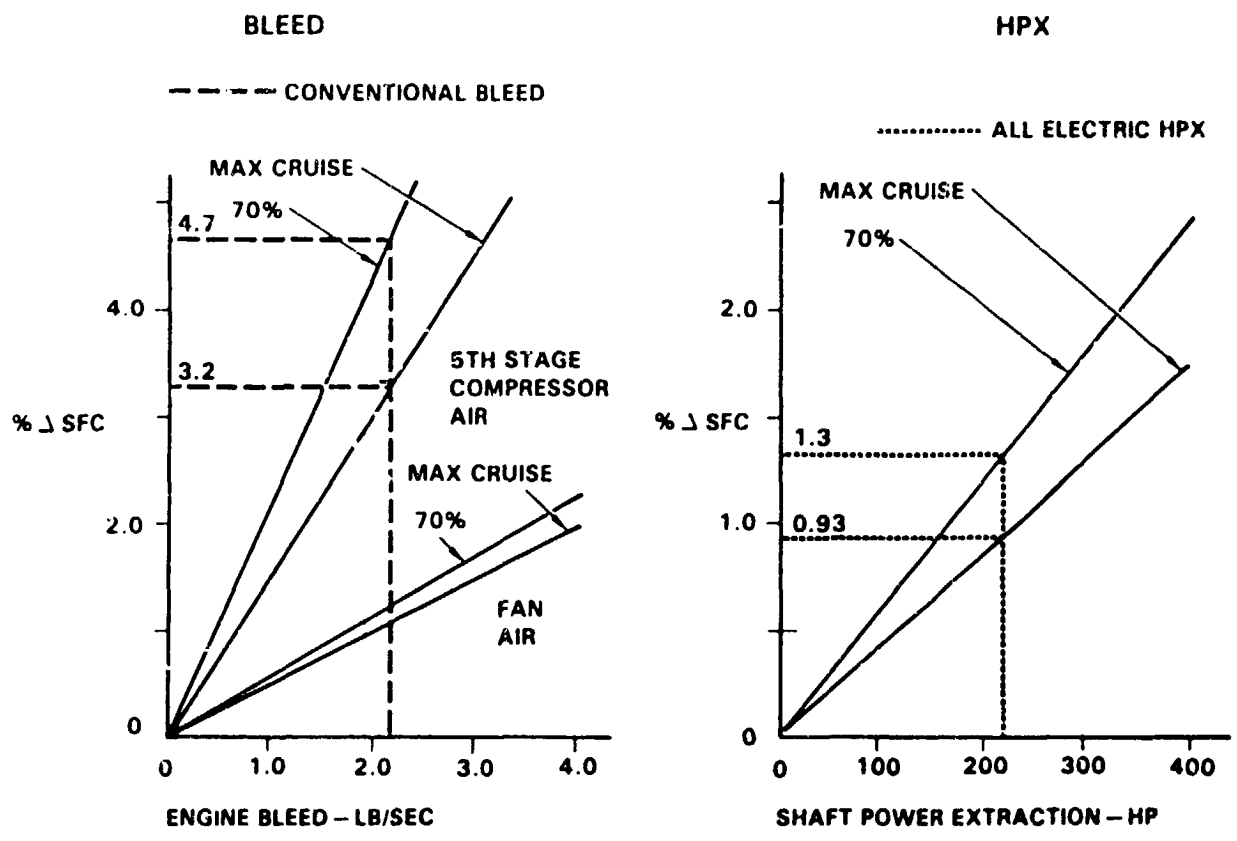
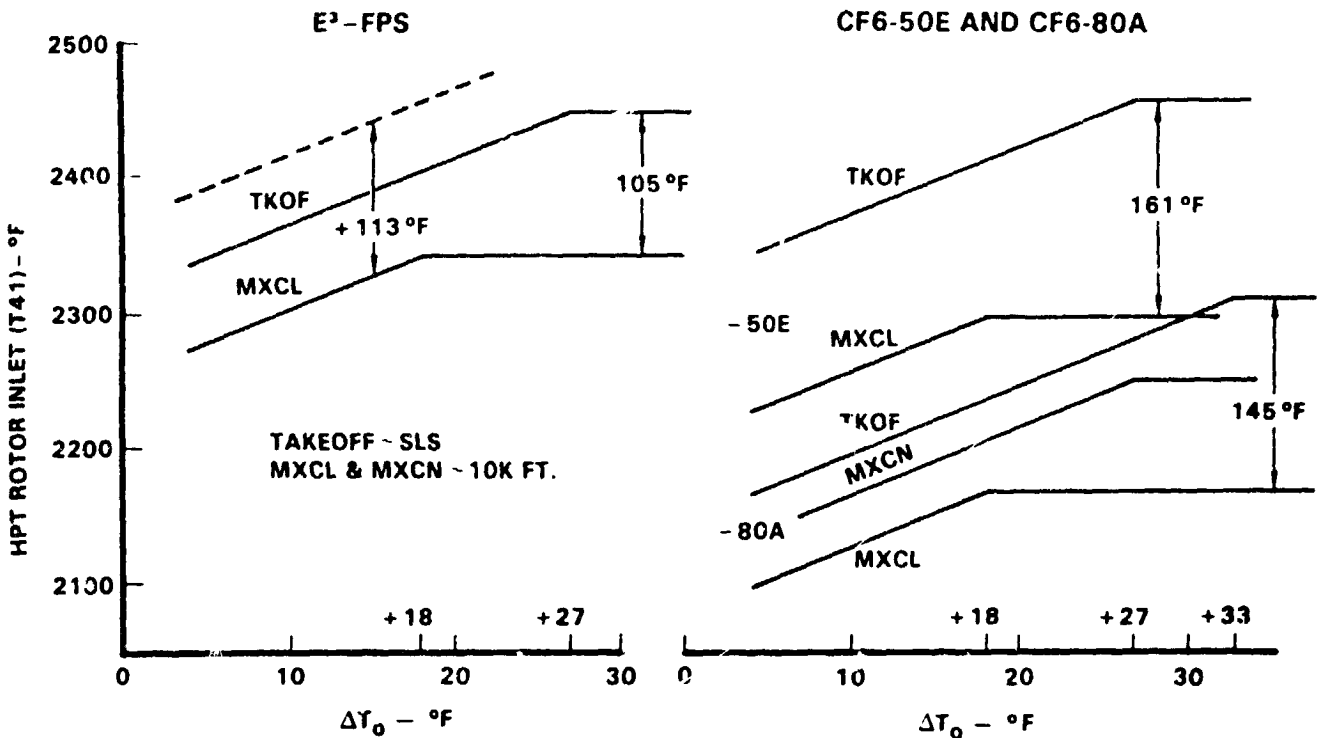

Figure 4. - Increase in sfc with 2.2-lb/sec bleed - altitude, 35 000 ft; Mach 0.8; standard day; constant thrust.

ORIGINAL PAGE IS  
OF POOR QUALITY



**FLAT RATING TEMPERATURE**

Figure 5. - Temperature margin for engine out - average engine-cycle deck.

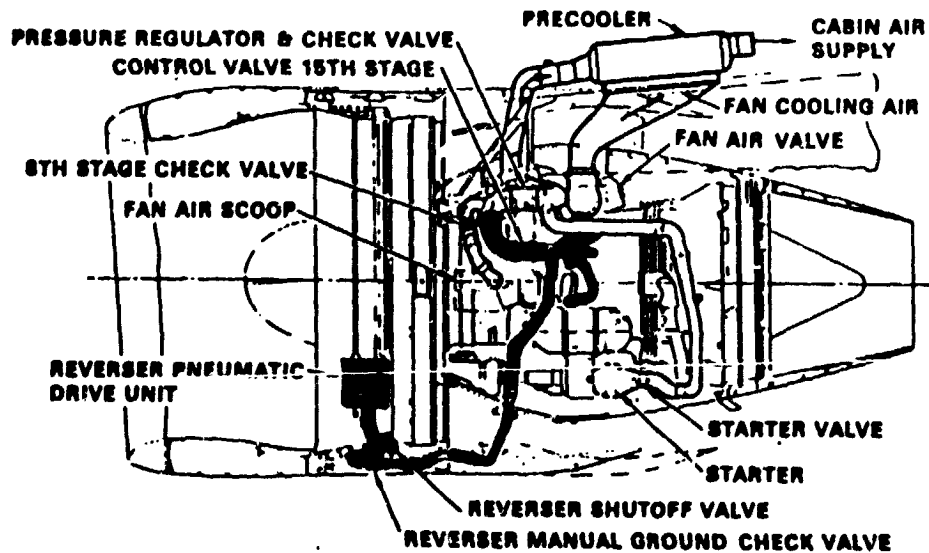

Figure 6. - Powerplant assembly - P&W JT90-7R4.

ORIGINAL PAPER OF POOR QUALITY

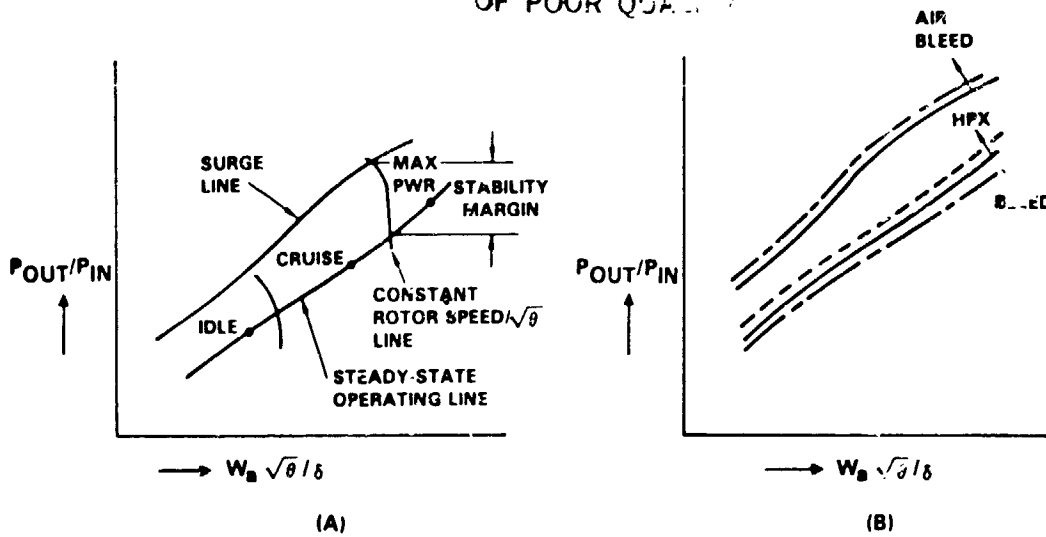

Figure 7. - Typical engine compressor map.

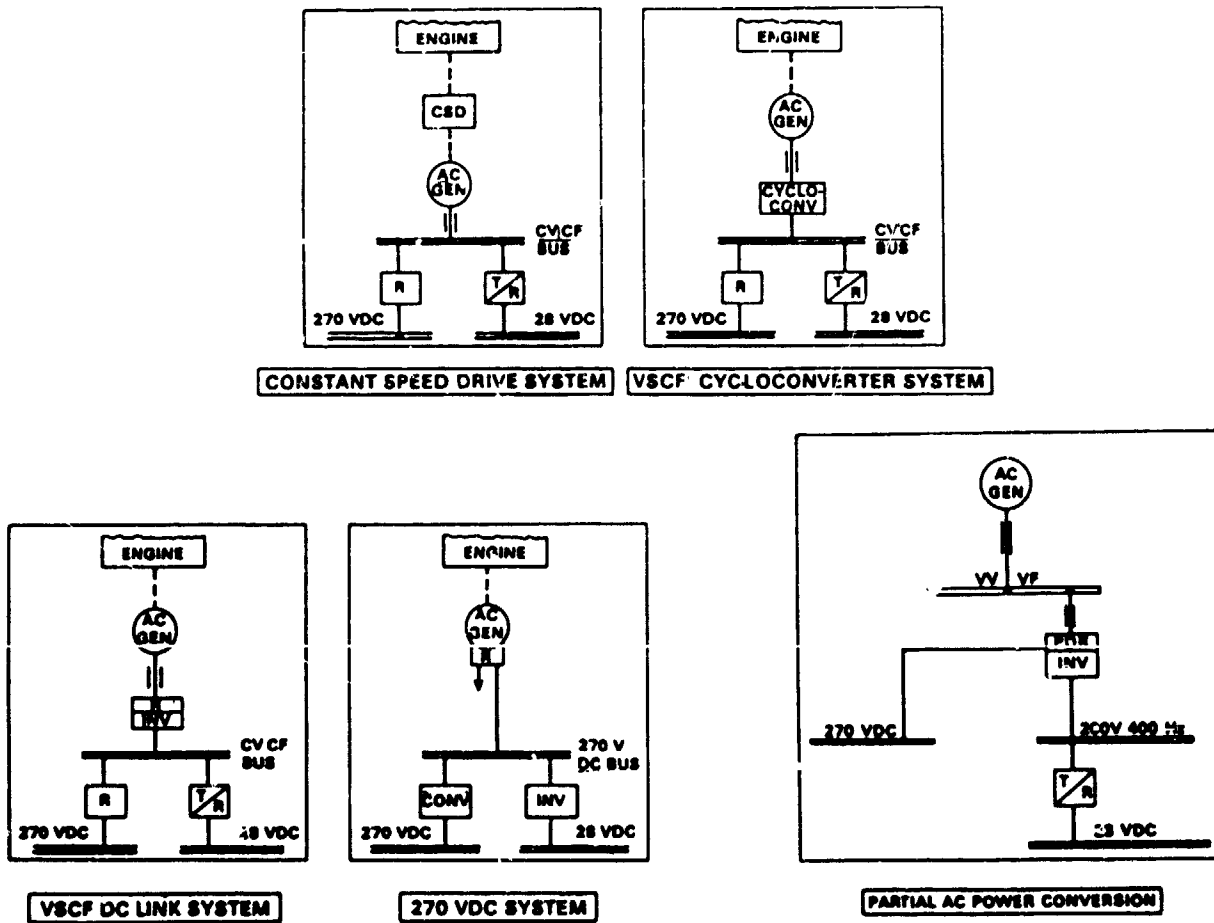

Figure 8. - Power generation systems.

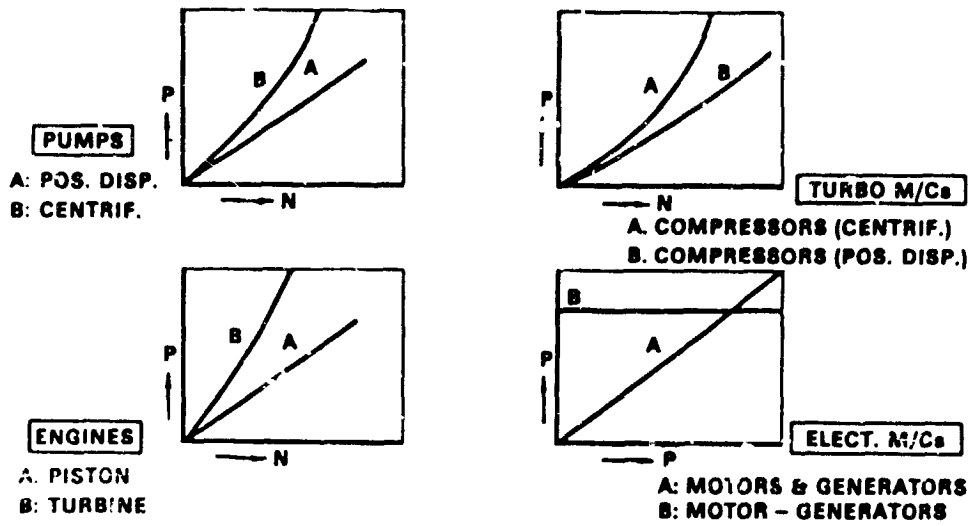

Figure 9. - Power output as a function of speed.

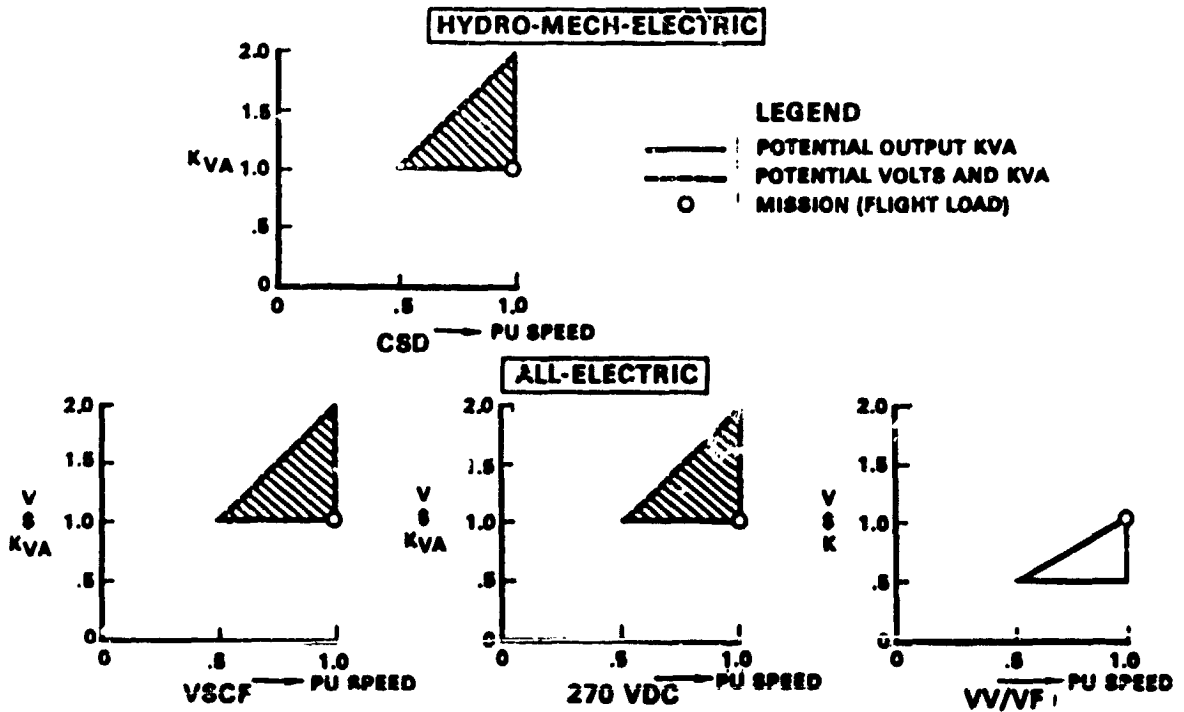

Figure 10. - Specific power system capability.

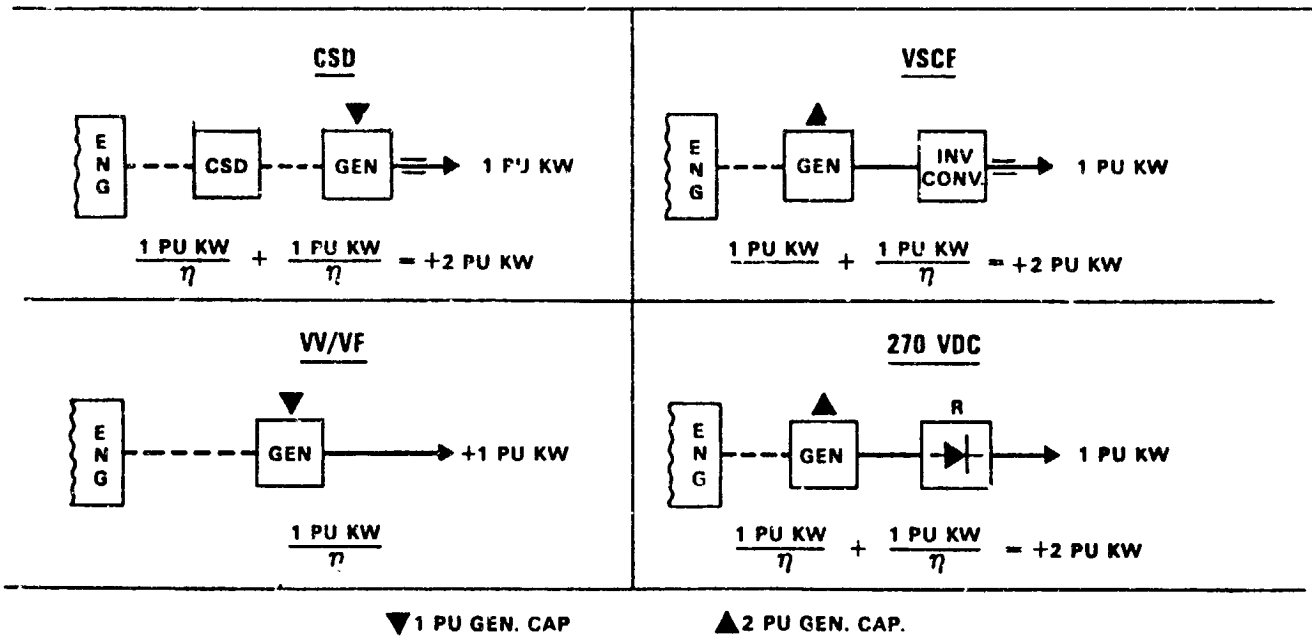

Figure 11. - Effect of speed range - based on 2:0 engine speed range.

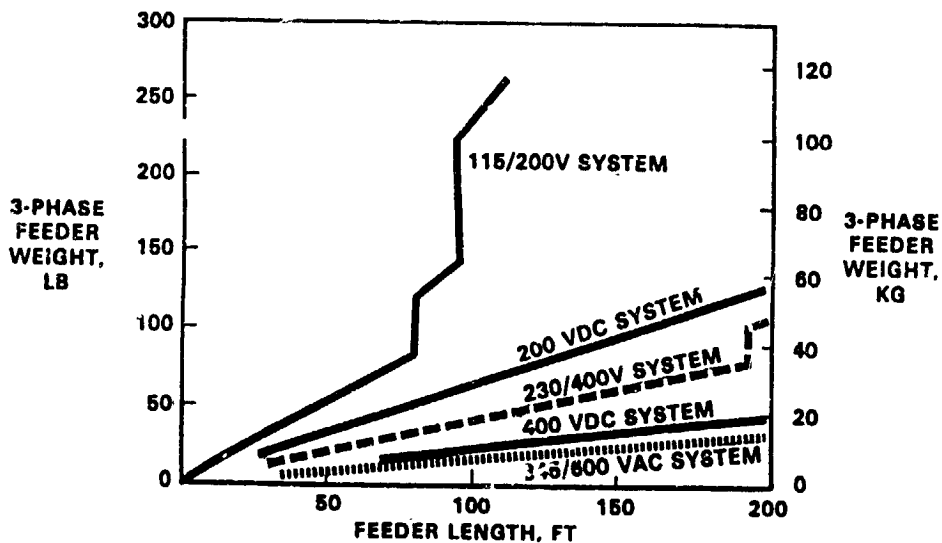

Figure 12. - Electric feeder weight as a function of transmission voltage and distance.

ORIGINAL PAGE 13  
OF POOR QUALITY

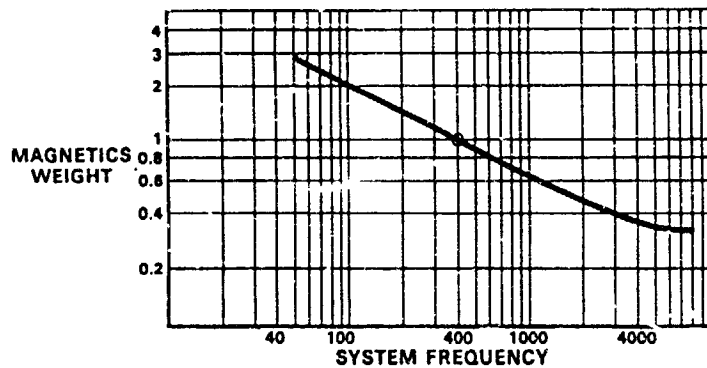

Figure 13. - Magnetics weight as a function of system frequency.

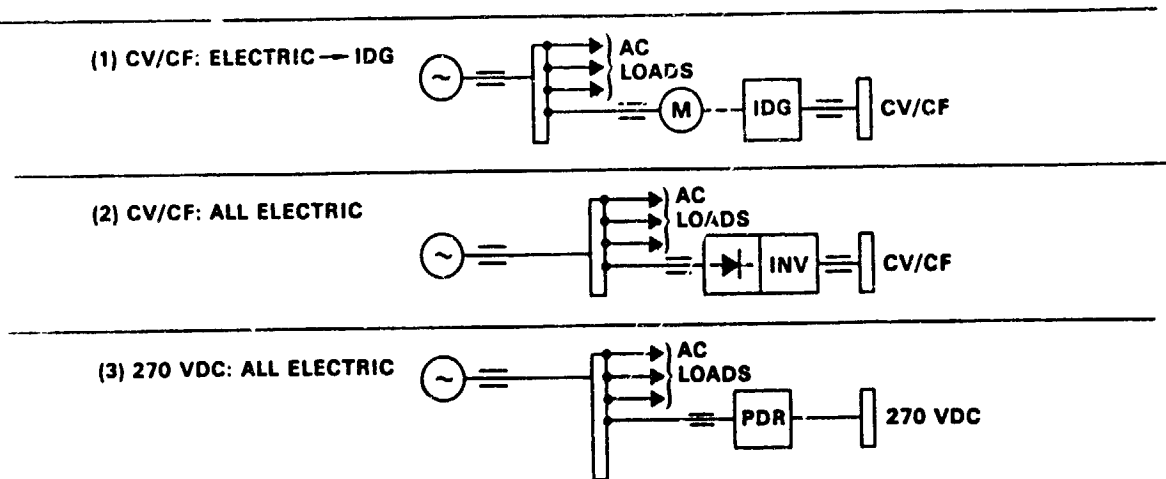

Figure 14. - Dedicated power sources from VVVF system.

ORIGINAL PAGE IS  
OF POOR QUALITY

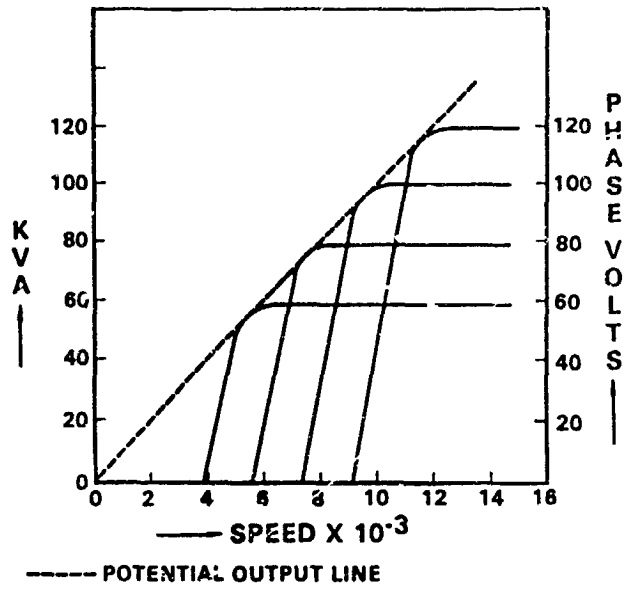

Figure 15. - Synchronous generator performance as a function of speed - brushless wound rotor.

• REGULATION A FUNCTION OF:

- ✓ IMPEDANCE DROP
- ✓ SYNCHRONOUS IMPEDANCE Z
- ✓ AIR GAP FLUX DENSITY
- ✓ CROSS-MMFs
- ✓ LOAD POWER FACTOR

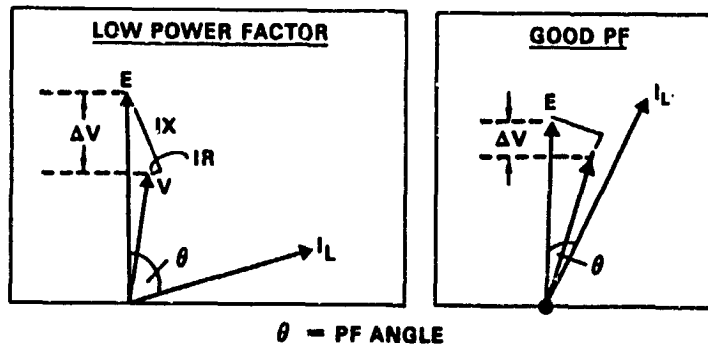
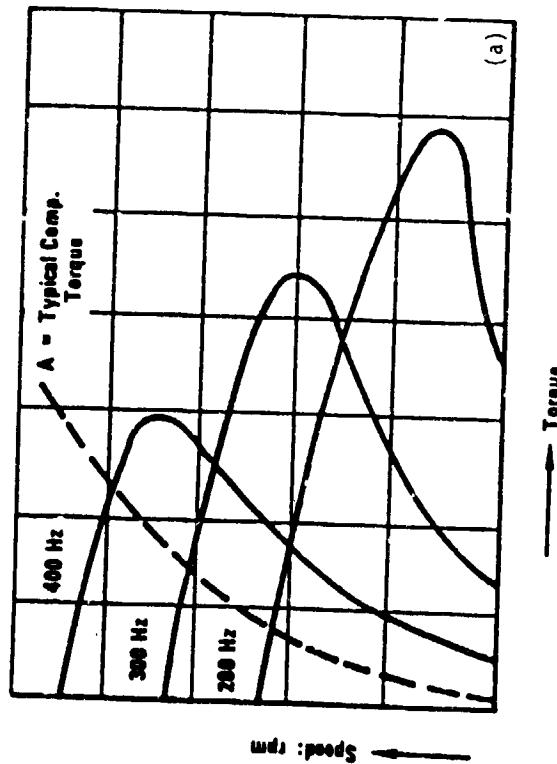
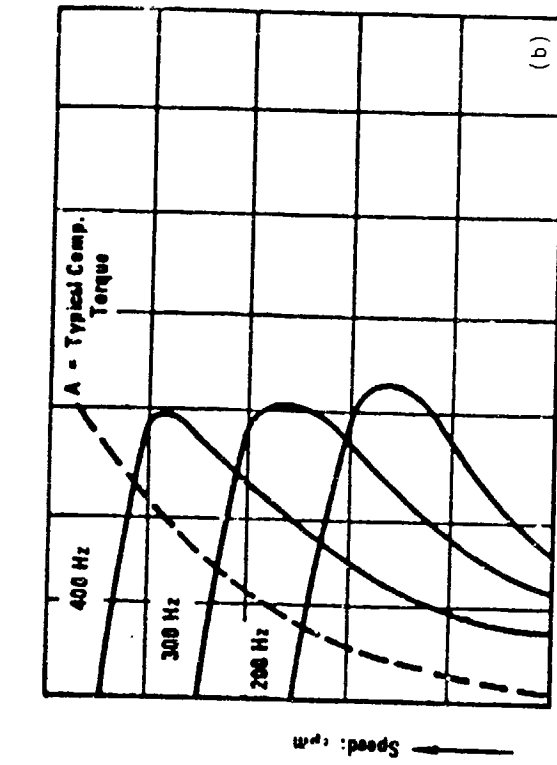

Figure 16. - VVVF generator regulation.





- (a) Voltage constant.
- (b) Voltage proportional to frequency.

Figure 17. - ac induction motor speed as a function of torque.

ORIGINAL PAGE IS  
OF POOR QUALITY

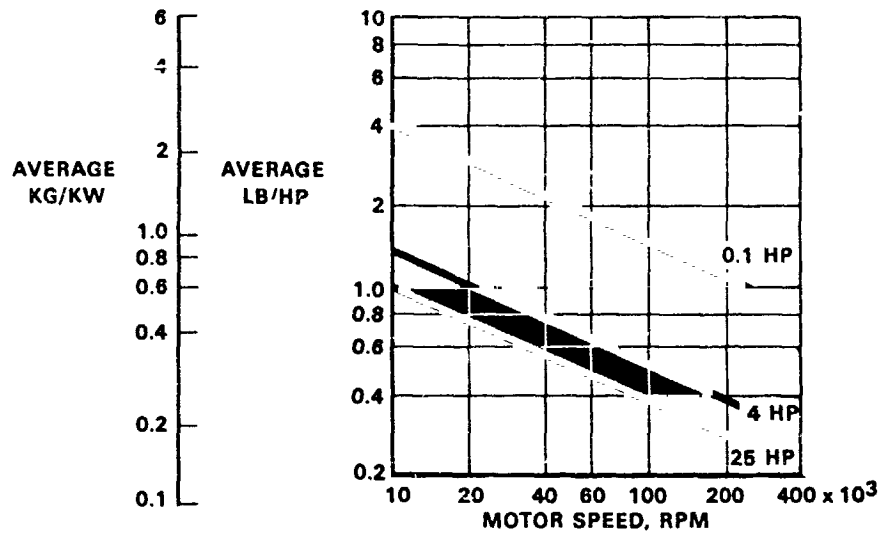

Figure 18. - Brushless dc motor weight as a function of speed - electronics weight excluded.

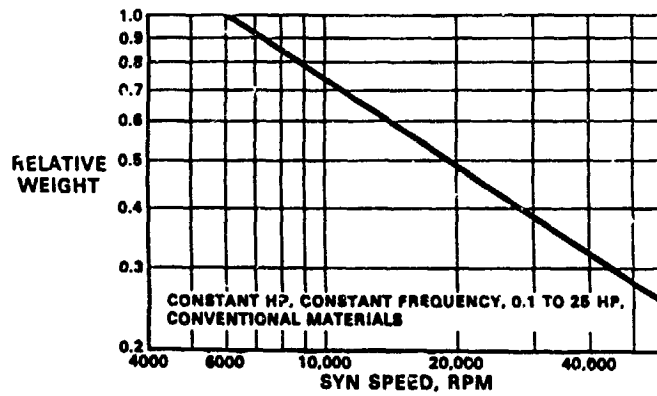

Figure 19. - Induction motor weight as a function of speed.

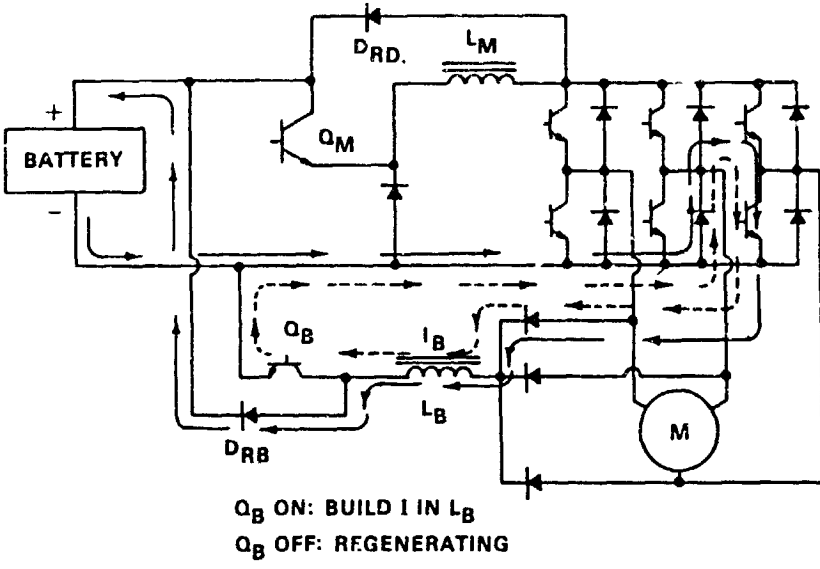

Figure 20. - Regeneration aspects of brushless dc motors.

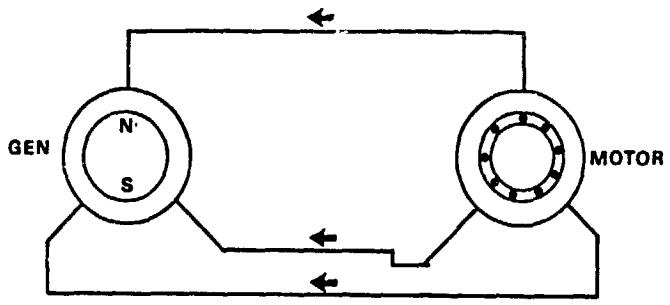

Figure 21. - Regeneration aspects of ac induction motors.

ORIGINAL PAGE IS  
OF POOR QUALITY

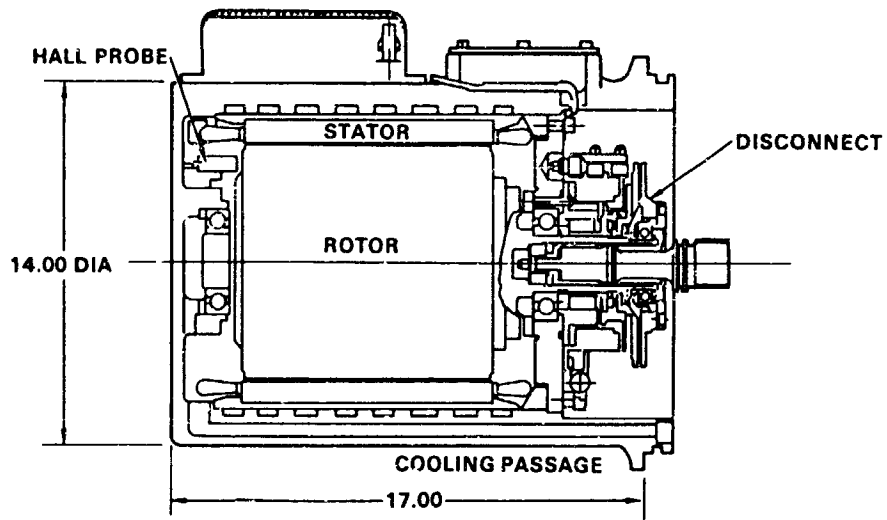

Figure 22. - Cross section of 150-kVA samarium-cobalt starter-generator.

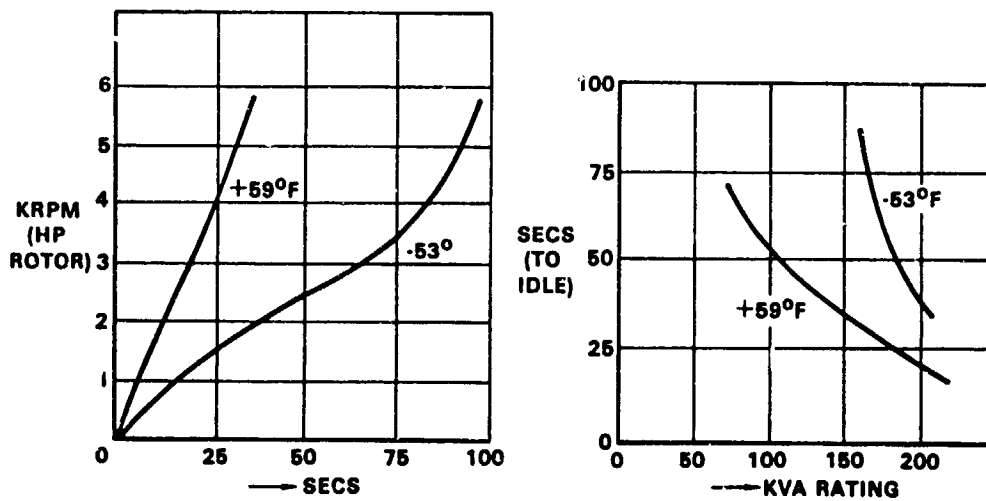

Figure 23. - RB-211 engine start times with samarium-cobalt starter-generator.

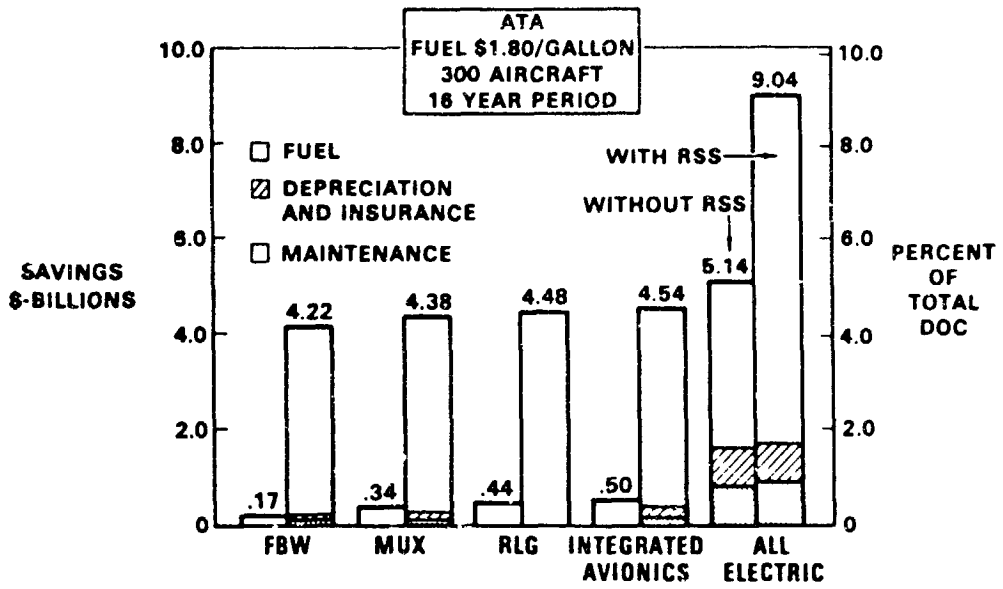

Figure 24. - Technology value of all-electric airplane.

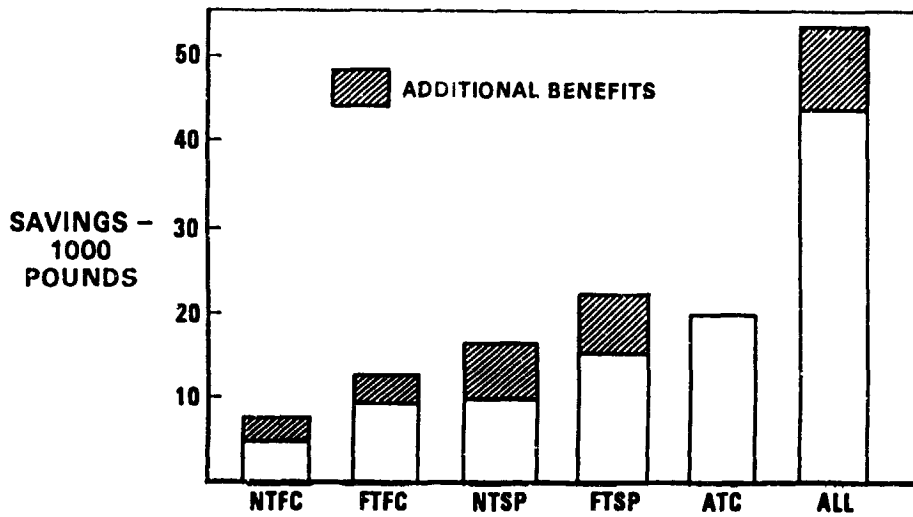

Figure 25. - Gross takeoff weight savings with 350-passenger airplane - NASA Lewis/Lockheed study.

ORIGINAL PAGE IS  
OF POOR QUALITY

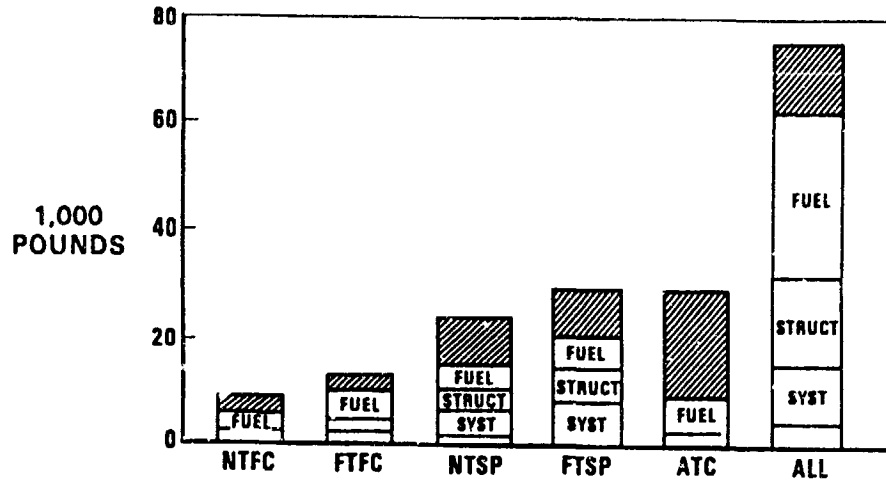

Figure 26. - Gross takeoff weight savings with 700-passenger airplane - NASA Lewis/Lockheed study.

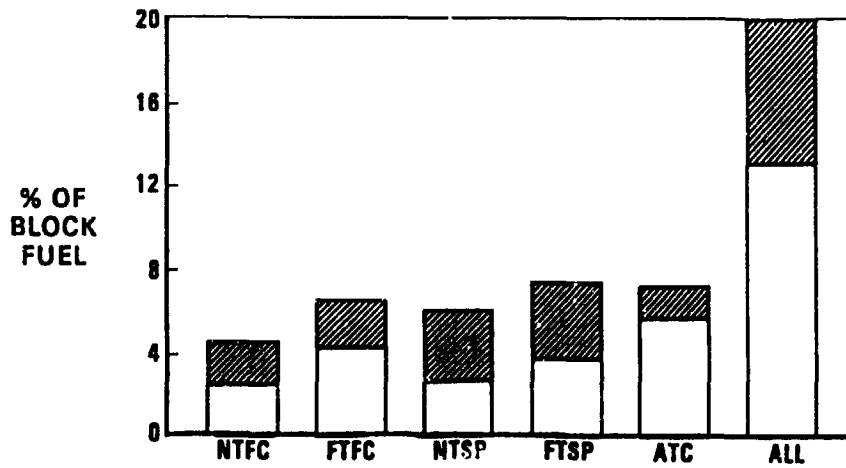

Figure 27. - Fuel savings with 350-passenger airplane - NASA Lewis/Lockheed study.