

N83 24898

D17

S
YLATCH FITTINGS FOR THE
SCIENTIFIC INSTRUMENTS ON THE SPACE TELESCOPE

Jan D. Dozier* and Everett Kaelber**

ABSTRACT

Latch fittings which kinematically mount the replaceable scientific instruments onto the Space Telescope must maintain precise alignment and thermal stability for on-orbit observations. Design features which are needed to meet stringent criteria include the use of ceramic isolators for thermal and electrical insulation, materials with different coefficients of thermal expansion for athermalization, precision manufacturing procedures, and extremely tight tolerances. A specific latch fitting to be discussed is a ball-and-socket design. In addition, testing, crew aids, and problems will be covered.

INTRODUCTION

Latch fittings for the scientific instruments (SI) and fine guidance sensors (FGS) on the Space Telescope are mechanisms which structurally support the instruments during launch and orbital operations. Designed to allow on-orbit replacement of an SI or FGS, the latch fittings must maintain precise registration of the instruments, provide alignment and stability during scientific observations, and minimize thermal conductance.

The latch fittings mount each SI or FGS onto the graphite-epoxy focal plane structure (FPS) of the ST in a statically determinate manner. Each of the four axial SI's is mounted with three latch fittings (Figure 1), the radial SI is mounted with three latch fittings (Figure 2), and each of the three Fine Guidance Sensors (FGS) is mounted with four latch fittings (Figure 3). Every latch fitting consists of one half mounted to the FPS and one half mounted to the SI (or FGS). Accounting for mirror image designs, there are a total of 20 different latch configurations.

The stringent alignment and functional requirements of the SI latch fittings make their design, manufacture, assembly, and qualification a challenging and unique engineering task. This paper will discuss design requirements of the latch fittings, the general design features needed to meet these requirements, a specific latch fitting of a complex design, verification and qualification testing, and problems.

*National Aeronautics and Space Administration, George C. Marshall Space Flight Center, Alabama

**Perkin-Elmer, Danbury, Connecticut

DESIGN REQUIREMENTS

The design driver for the SI latch fittings is the stringent alignment requirement. The instrument position during initial alignment must be known within 10 μm . If the instrument is replaced, the alignment must be repeated within 15 μm . Furthermore, during scientific observation, the twenty-four hour stability requirement for the latch fittings is that the SI alignment must be maintained to within .0013 arc second. Alignment and stability are verified by analysis.

In order to minimize heat loss between the SI and the FPS, the mount point conductance for each latch half must be less than 0.050 Watt/ $^{\circ}\text{C}$. Conductance is verified by analysis. Distortion due to thermal deformation of an instrument or the FPS may also induce a moment across a latch fitting interface. Therefore, the maximum residual moment, or breakaway torque of a latch fitting, is restricted. The maximum breakaway torque for each latch fitting is determined by test.

Structurally, the latch fittings are designed to support the instruments and to withstand the shuttle launch and landing loads. For the stress analysis, a factor of safety of 1.4 is used on ultimate strength and 1.1 is used on yield strength. Strength is verified with a static load test on each mated latch fitting. Dynamic tests of all-up SI simulators and latch fittings are used to verify mechanical integrity. These tests will be discussed later.

Other design requirements include crew systems compatibility and constraints on physical dimensions and weight.

DESIGN FEATURES

Each latch fitting is designed to take loads in one, two, or three directions so that the instrument is supported with a statically determinate system. Therefore, a set of latch fittings kinematically mounts each SI or FGS with six degrees of freedom.

The thermal paths between the FPS and SI must be isolated to meet the alignment requirement and the .050 Watt/ $^{\circ}\text{C}$ conductance requirement. Therefore, a common design feature of the latch fittings is the use of glass-mica to insulate the attachment bolts and shear pins. Machined inserts are used to insulate the attachment bolts and injection molds are used to surround each shear pin. Because of the brittle nature of the glass-mica ceramic, it is capable of compression loading only. Therefore, shear load paths must be separated from the tension/compression load paths and the design of the latch fittings becomes complex. Thermal load paths for a typical fitting are shown in Figure 4. Additional thermal requirements are met using materials with low, yet compatible, coefficients of thermal expansion.

Two of the latch fittings, point A of the radial SI and FGS, and point A of the axial SI, are designed to take loads in three directions. Although of different detail configurations, each of these latch fittings is basically a ball-and-socket design. Rotation of the ball is restricted by the space limitation, and it is self-aligning. The 440C stainless steel ball is machined to a sphericity within $1\ \mu\text{m}$ ($40\ \mu\text{-in.}$) Each of these latch fitting designs is actuated with a rod which can be torqued and untorqued by an astronaut during an on-orbit mission. The axial SI point A latch has titanium jaws which close on the ball when a $60\ \text{Nm}$ ($44\ \text{ft-lb}$) torque is applied. During manufacturing, these jaws are clamped, then thermally aged and stabilized for one week before final machining to a sphericity within $1\ \mu\text{m}$. The clearance between the ball and jaws is $2\ \mu\text{m}$ on the diameter and the maximum moment transmitted is less than $31\ \text{Nm}$ ($23\ \text{ft-lb}$) when preloaded. Point A of the radial SI and FGS is a ball captured with a threaded rod and seated with a $60\ \text{Nm}$ ($44\ \text{ft-lb}$) torque. This latch fitting will later be discussed in detail.

Point B of the axial SI is designed to transmit loads in two directions and applies a $3560\ \text{N}$ ($800\ \text{pound}$) preload along the longitudinal axis of the axial SI. This latch fitting has a large spring at the aft end of the instrument which applies the preload through a linkage mechanism. A threaded actuation rod applies a $10\ \text{Nm}$ ($90\ \text{in-lb}$) torque and enables an astronaut to engage the fitting. The maximum residual moment allowed across point B is $54\ \text{Nm}$ ($40\ \text{ft-lb}$).

Switches for crew aid indicator lights are located on each radial SI and FGS point A latch, axial SI point A latch, and on the axial SI guiderail. These lights tell the astronaut when the ball is seated in its socket, when to begin torquing, or when the preload has been applied.

The remaining latch fittings take load in one or two directions only and do not transmit moments. Basically, the design is a self-aligning cylinder which registers against a flexure within a mating receptacle. A spherical stem is sprayed with aluminum oxide coating and cylindrical shells of 440C stainless steel are clamped around the ball with a retaining ring. The clearance between the shells and the ball allows a 2° rotation, thus giving the ball its self-aligning capability. This cylinder is inserted into a rectangular titanium receptacle and registers against a 15-5 Ph steel flexure. Thus, the load path is along the line of contact between the ball and the flexure. All of these types of latch fittings are passive, in that they become engaged when the active fittings are torqued and latched.

SPECIFIC DESIGN

A complex latch fitting design is that of point A of the radial SI and FGS. As described earlier, this ball-and-socket design takes load in three orthogonal directions. The fitting is lightweight, yet strong enough to meet the strength criteria. It also enables on-orbit instrument removal and installation by an astronaut, and realigns the new instrument to extremely

close tolerances. Thermal conductance and electrical resistance requirements are also included in the design.

The 24-hour stability requirement combined with the space limitation of the FPS hub forces complexity into the fitting design. Governed by the 24-hour stability requirements, the allowable thermal expansion between the radial SI and the FPS is $.5 \mu\text{m}$ ($19 \mu\text{-in.}$). Thus, an athermalized design is required and, as shown in Figure 5, consists of nested parts of titanium, Invar, and aluminum. The thermal growth of the titanium base and the Invar stem is counteracted by the growth of the aluminum cover. Aluminum or Invar shims are used for adjustments at the final assembly. Athermalization of the FPS half of the fitting is analytically determined, but can be verified with an interferometer.

The Ti-6Al-4V titanium ball depicted in Figures 5 and 6 is able to swivel 2° and the clearance between the ball and its titanium housing is $1\text{-}1.5 \mu\text{m}$ ($40\text{-}60 \mu\text{-in.}$) on the diameter. By referring to Figure 7, it can be seen that vertical load taken by the ball is transmitted to the Invar stem and aluminum cover through a center bolt, then to the titanium base through the stiff axis of three steel flexures. Each flexure has only one attachment bolt per end, necessitating a tapered interference fit to react the moment. One end of the flexure is attached to the titanium base and the other end attaches to the aluminum cover. Therefore, these flexures are designed to deflect outward under distortion resulting from the different coefficients of thermal expansion between aluminum and titanium. Radial load taken by the ball is transferred to the titanium base with shear slugs. As shown in Figures 5 and 6, these shear slugs consist of a glass-mica insert bonded to a self-aligning set of spherical washers. Any remaining "kick" load is taken up by the weak axes of the three flexures.

A threaded rod inserted into the ball engages the fitting when a 60 Nm (44 ft-lb) torque is applied. Springs between the ball and the SI half of the fitting apply 1245 N (280 lbs) of preload to ensure that the ball remains registered to the upper half of its housing.

TESTING

Factors of safety used by Marshall Space Flight Center for untested flight hardware are 2.0 for ultimate strength and 1.25 for yield strength. However, structural verification by test is required if the 1.4 and 1.1 factors of safety are used for ultimate strength and yield strength, respectively. The test criteria were chosen for the SI latch fittings in order to conserve weight and to reduce complexity in design. Each mated latch fitting configuration is statically tested to loads equivalent to shuttle launch or landing. Before the test, baseline dimensions are measured and strain gages are applied at locations determined by the brittle lacquer technique. A functional test is performed after exposure to 1.0 times the limit load. After applying 1.1 times the limit load, measurements are taken to determine the degree of permanent yielding. After the latch fitting is tested to 1.4 times the limit load, it is disassembled and inspected for cracks.

3
Y

A dynamic test is conducted on each axial SI, radial SI, and FGS configuration, with their respective latch fittings mounted. The most severe load case is simulated by a series of transient shock spectra and random vibration tests for each axis. From these tests, alignment and stiffness data are obtained, as well as information on the mechanical integrity of the latch fittings.

Crew aids accessibility and functional requirements of the latch fittings are tested in Marshall Space Flight Center's Neutral Buoyancy Simulator. Full scale mock-ups of the ST are placed in a large water tank, where weightlessness is simulated by the buoyant effect of the water. The astronauts then remove and install instruments in a simulated zero g environment. Further information on these tests is given in NASA Technical Memorandum 82485 ("Space Telescope Neutral Buoyancy Simulations - The First Two Years," Fred G. Sanders, June 1982).

PROBLEMS

Glass-Mica (Injection molded)

Injection molded glass-mica surrounds a knurled steel pin and is molded into a titanium base. The glass-mica is injected at 276 MPa (40,000 psi) and 760°C (1400°F), requiring extensive tooling. Initial samples exhibited "knit" lines in the direction of the flow, at the point of injection, and at the juncture where the material flowed around the pin. These knit lines appeared as cracks and contained some machining oil, causing contamination. The knit lines were virtually eliminated by a change in the stress relief cycle. This cycle consisted of increasing and decreasing the temperature at 38°C (100°F)/hour. Machining oil was eliminated from the process and the bases were baked out to reduce contamination.

Also, the glass-mica was loose at the titanium base interface after the bases were stress-relieved. This looseness could have contributed to misalignment of the instrument. Looseness which exceeded the alignment error budget tolerance was brought within tolerance by vacuum impregnating the glass-mica interfaces with the epoxy.

Glass-Mica (Bar stock)

Bolt isolators and shear slugs are machined from bar stock glass-mica. During assembly and during the strength tests, this glass-mica was found to be very brittle, especially under point loads. Tighter control of coplanarity and parallelism to the drawings of the bolt isolator bearing surfaces has reduced the occurrence of fracture during assembly. However, a redesign of the shear slugs was necessary. The original design has a set screw tightening a flat washer against the end of a glass-mica cylinder, whereas, the redesigned shear slug has a set screw which bears on a set of spherical washers that are bonded to the glass-mica cylinder. This self-aligning feature prevents the set screw from point loading the glass-mica.

Aluminum Oxide

Aluminum oxide is used to coat some of the spherical surfaces in order to reduce friction. The use of liquid lubrication is severely restricted because of potential contamination. Interior balls in the self-aligning cylinders (axial SI point C, radial SI points B and C, FGS points B, C, and D) and the self-aligning captured balls (axial SI point B, axial SI point A, and radial SI and FGS point A) were plasma sprayed with aluminum oxide.

During the dynamic tests, pieces of the aluminum oxide on the surface of the axial SI point A 440C stainless steel ball chipped off. These broken pieces were abrasive and severely galled the mating titanium jaws. A redesign was therefore necessary and, at this writing, is underway. The proposed design coats the titanium jaws with a tungsten carbide/cobalt material. The aluminum oxide coating has been deleted from the point A ball designs, which now use an uncoated steel ball.

Galling

The self-aligning steel cylinders which register against a 15-5 Ph flexure also bear against a titanium base. During the vibration environment of the dynamic tests, the steel cylinders severely galled the titanium surface and also galled the 15-5 Ph steel surface. This galling is unacceptable if the alignment error budget is to be met. Therefore, the titanium and 15-5 Ph bearing surfaces are now coated with a tungsten carbide/cobalt material. These coated latch fittings will be subjected to more dynamic testing before the proposed design is accepted.

Residual moment

The residual moment, or breakaway torque, at the axial SI points A and B latch fittings was originally limited to 22 Nm (16 ft-lbs). When tested, the fittings transmitted much higher torques. Therefore, lubricant was added to the ball surface to further reduce friction. In addition, the preload at point B was reduced from 4893 N (1100 lbs) to 3560 N (800 lbs). After an evaluation by each scientific instrument contractor, an increase in residual moment at each fitting was approved. The axial SI point A latch fitting residual moment is now a maximum of 31 Nm (23 ft-lb) and the axial SI point B latch fitting has a maximum residual moment of 54 Nm (40 ft-lb).

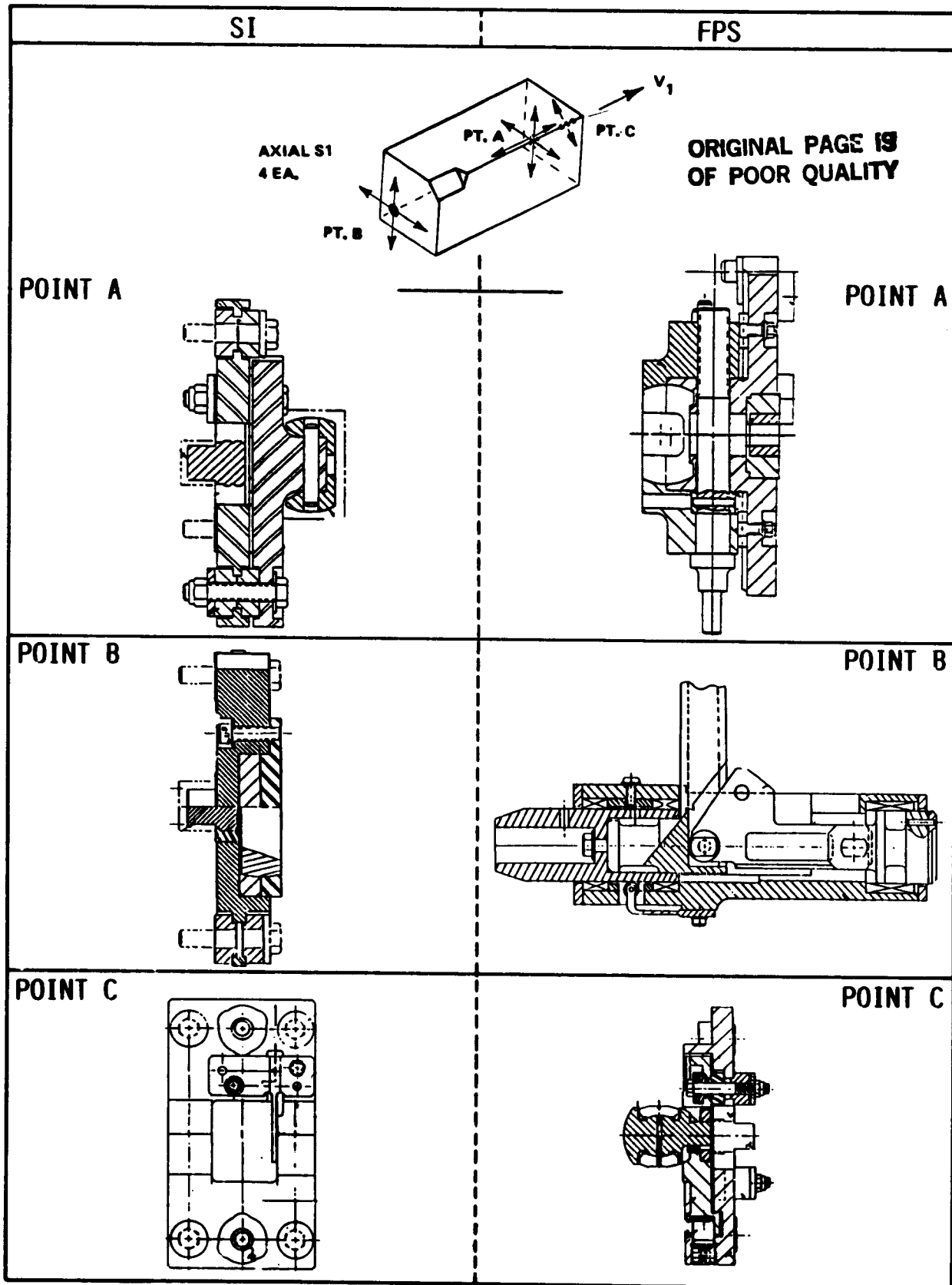

Figure 1. Axial Scientific Instrument Latch Fittings

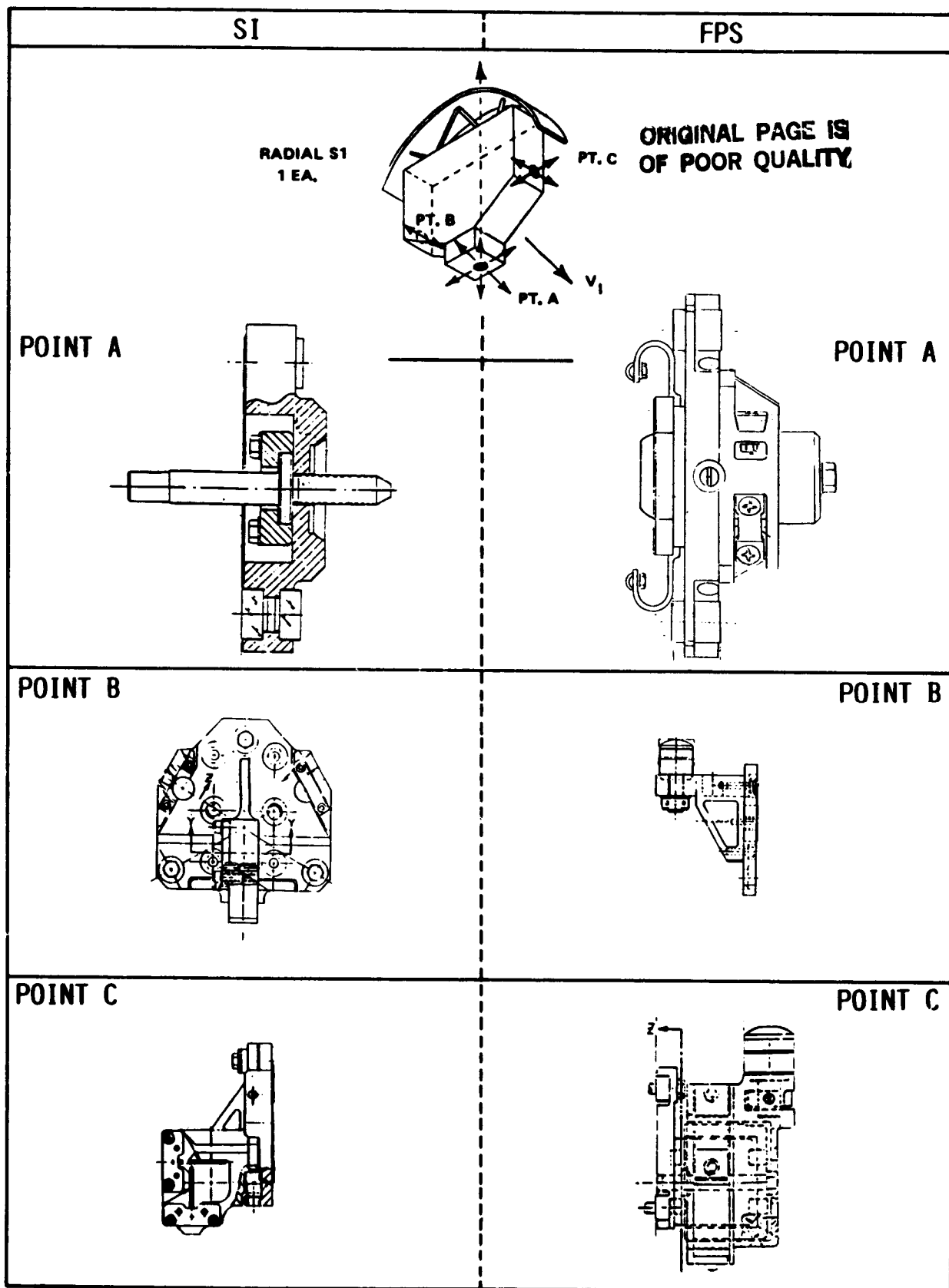

Figure 2. Radial Scientific Instrument Latch Fittings

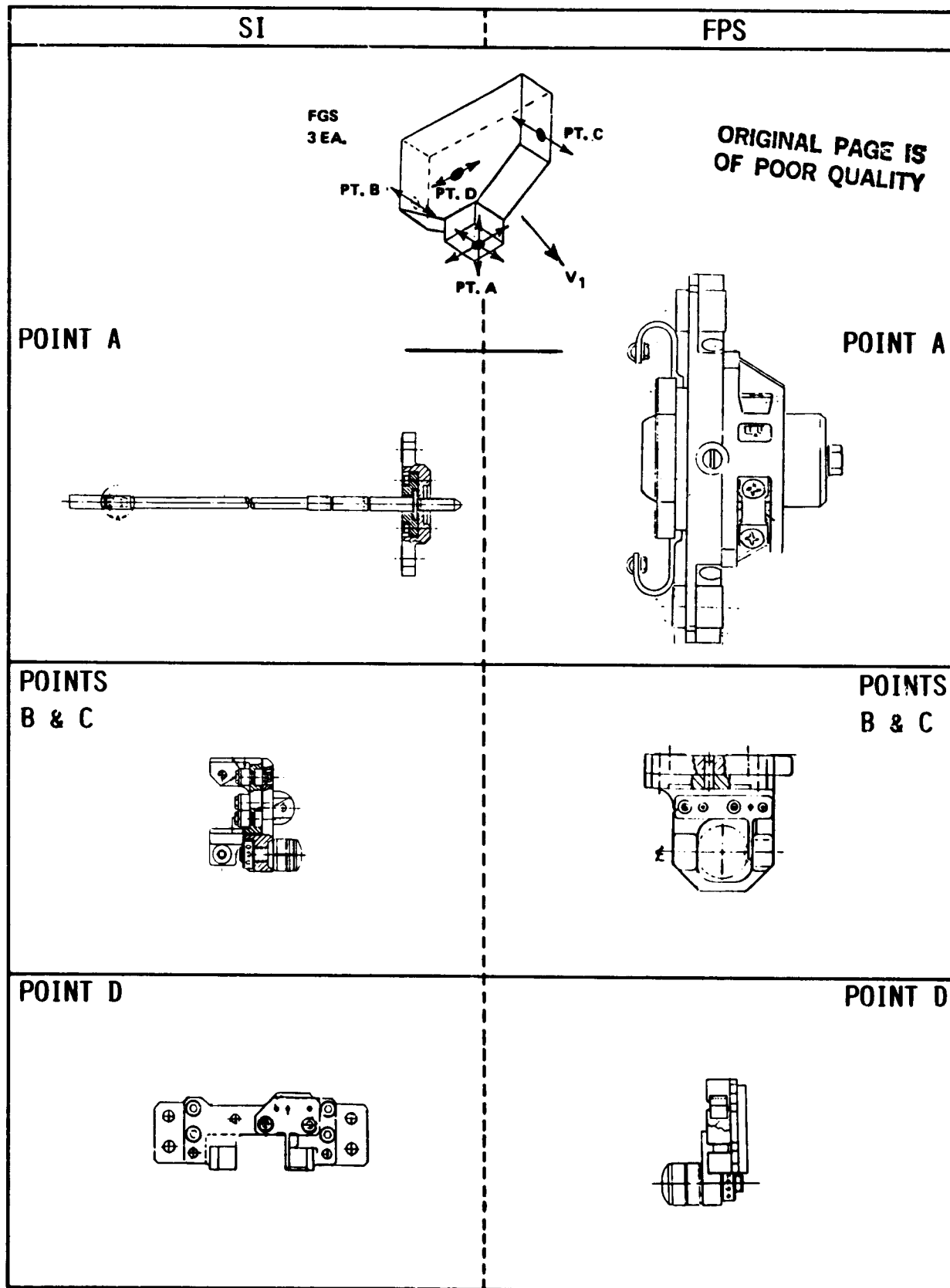
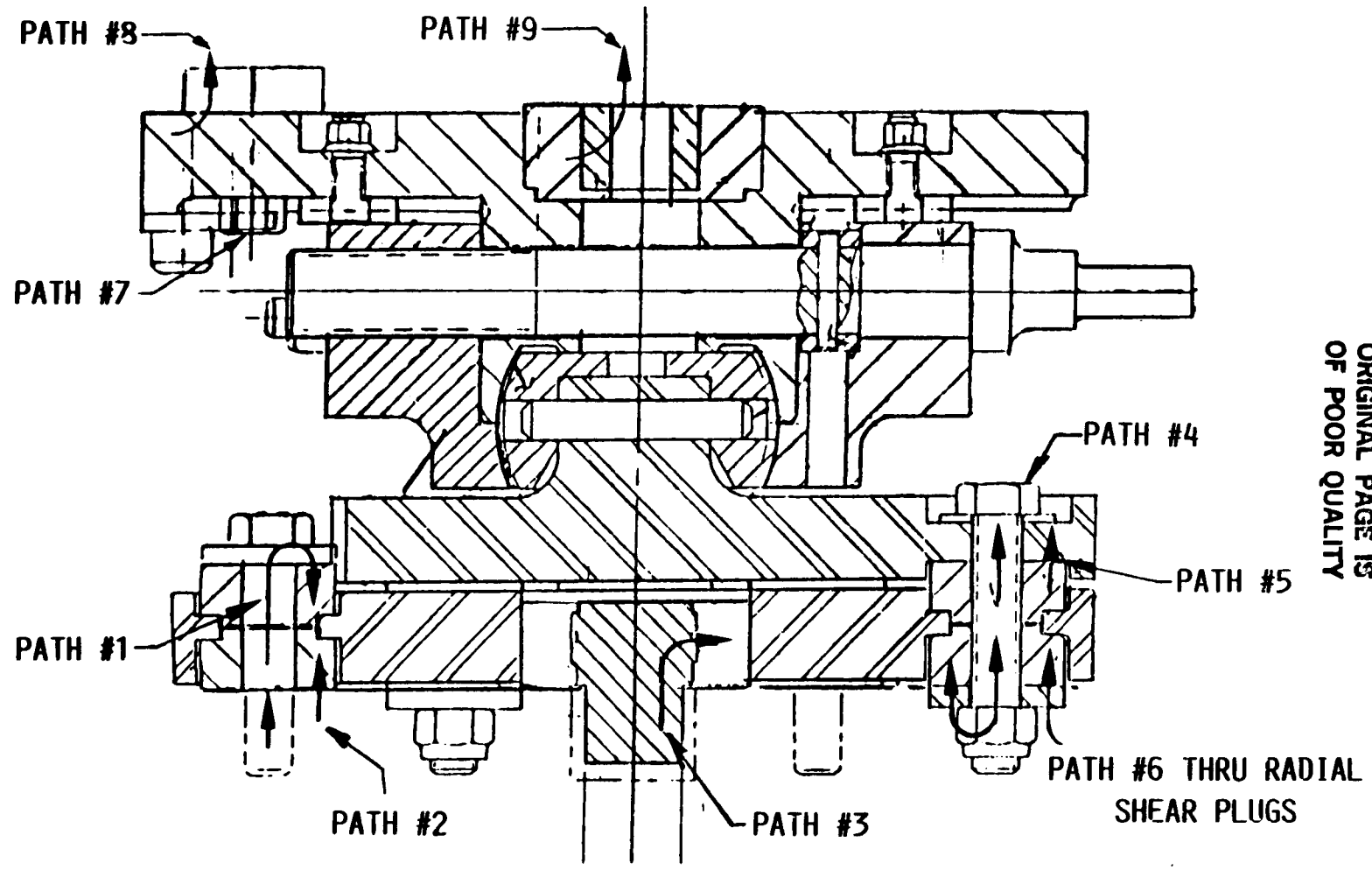

Figure 3. Fine Guidance Sensor Latch Fittings



ORIGINAL PAGE IS
OF POOR QUALITY

Figure 4. Thermal Paths, Axial SI Point A

ORIGINAL PAGE IS
OF POOR QUALITY

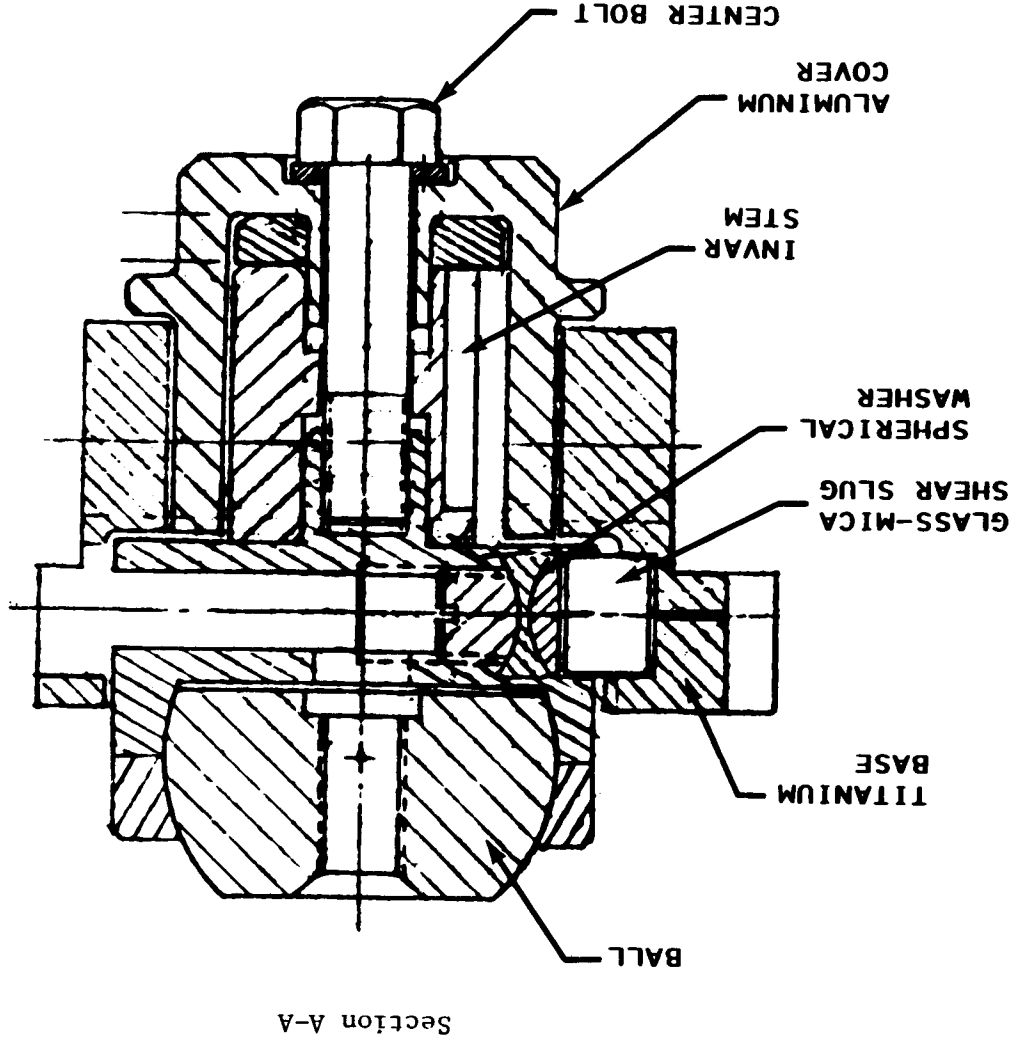

Figure 5. Radial SI and FGS Point A, FPS Half

264

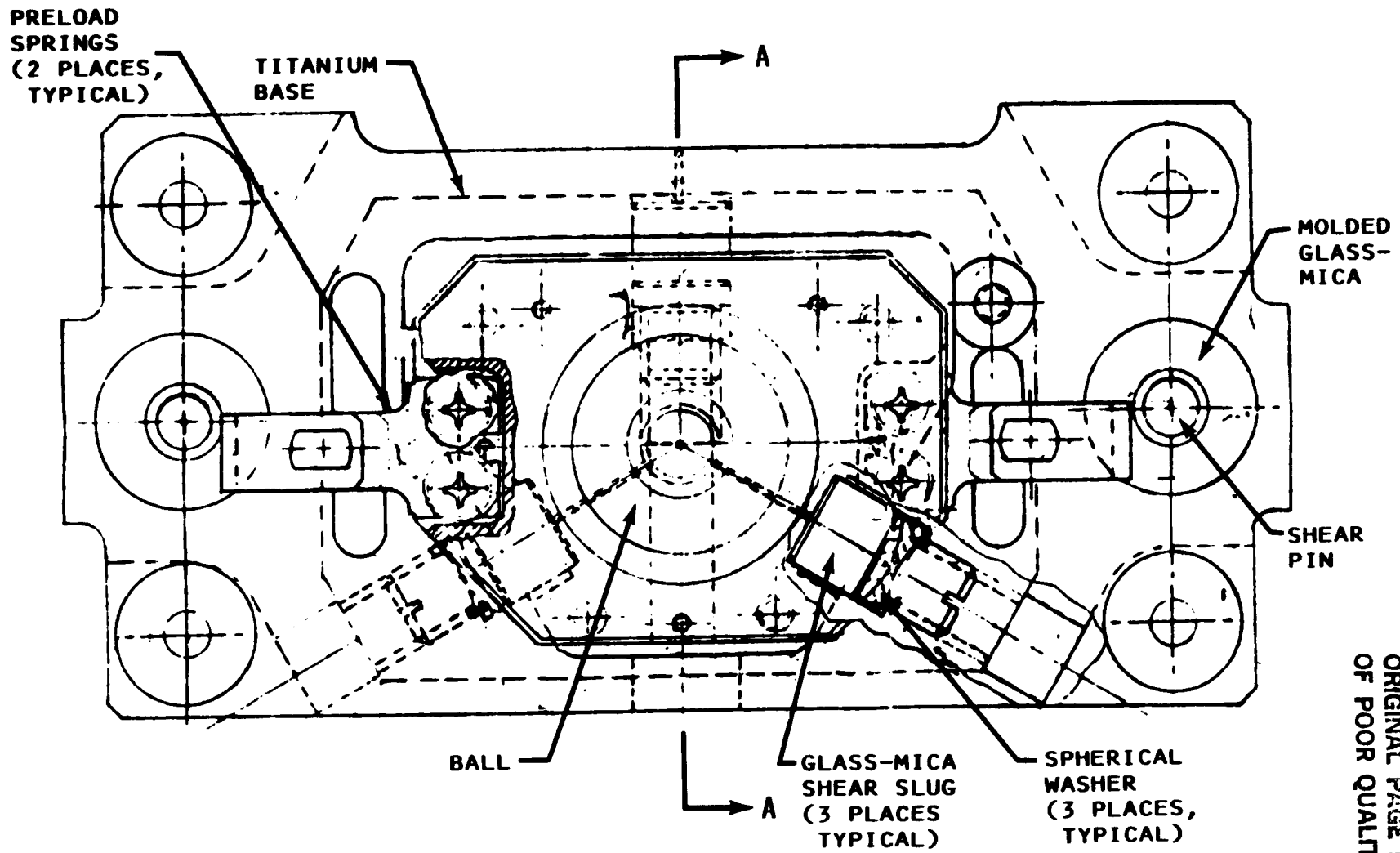

Figure 6. Top View, Radial SI and FGS Point A, FPS Half

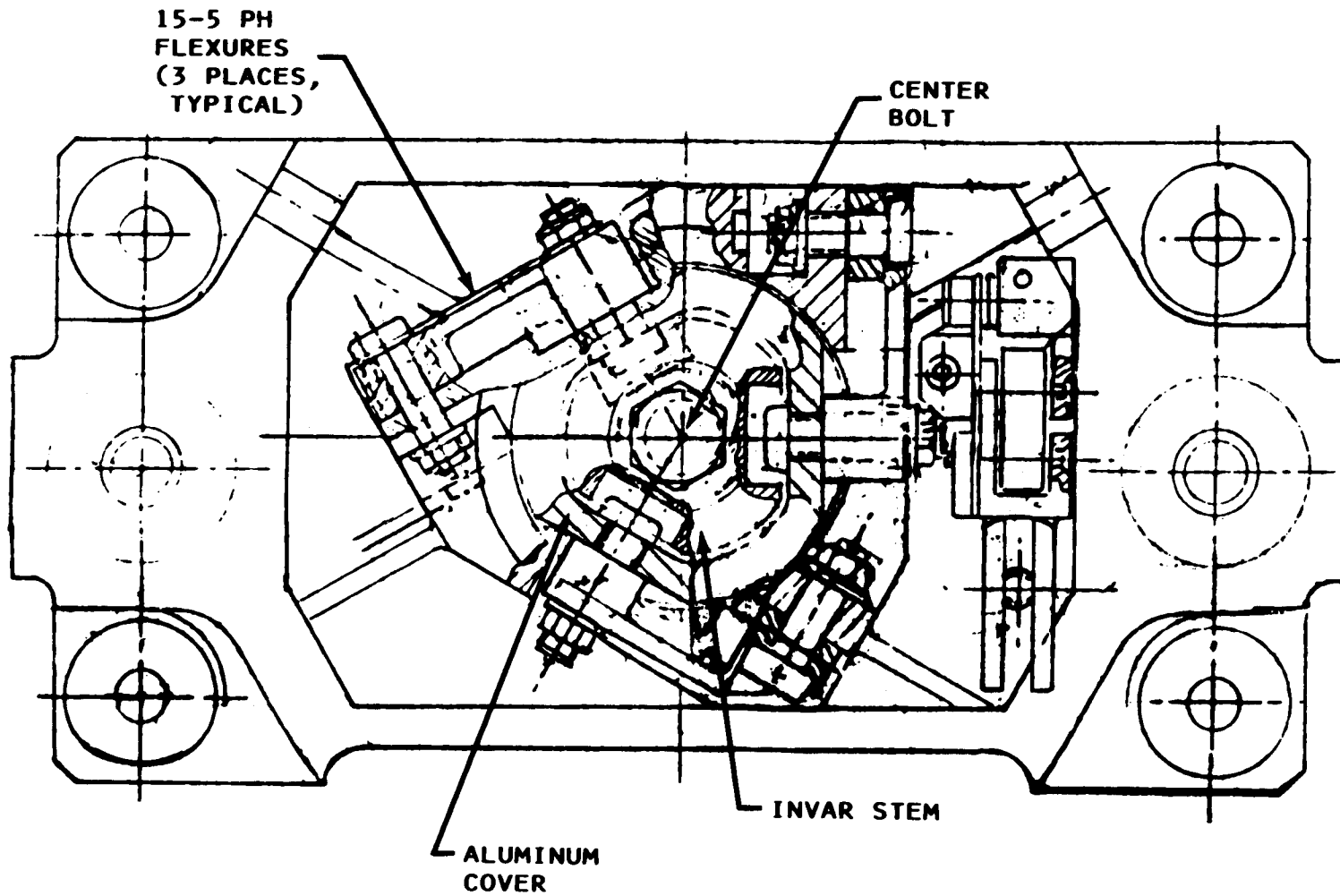

Figure 7. Bottom View, Radial SI and FGS Point A, FPS Half

ORIGINAL PAGE IS
OF POOR QUALITY