

N83 19265

934

AN OVERVIEW OF LARGE WIND TURBINE TESTS BY ELECTRIC UTILITIES

by

William A. Vachon and Daniel Schiff
Arthur D. Little, Inc.
20 Acorn Park
Cambridge, Massachusetts 02140

ABSTRACT

A summary of recent plans and experiences on current large wind turbine (WT) tests being conducted by electric utilities is provided. The test programs discussed do not include federal research and development (R&D) programs, many of which are also being conducted in conjunction with electric utilities. The information presented is being assembled in a project, funded by the Electric Power Research Institute (EPRI), the objective of which is to provide electric utilities with timely summaries of test performance on key large wind turbines. A summary of key tests, test instrumentation, and recent results and plans is given. During the past year, many of the utility test programs initiated have encountered test difficulties that required specific WT design changes. However, test results to date continue to indicate that long-term machine performance and cost-effectiveness are achievable.

INTRODUCTION

In the past two to three years, several electric utilities have initiated large WT test programs aimed at obtaining "hands-on" experience with large wind machines interconnected with their networks [1-3]. These programs have been conducted in parallel with--and often complementary to--the federal large WT development and test programs. This paper summarizes findings from a project sponsored by EPRI, which has as an objective the assessment of results from both federal and privately funded large* WT tests and to communicate key results to the electric utility industry. Thus far, three reports have been written on this project and are available from EPRI [4-6].

The major sources of data for this project are:

*Large WT's are those with $P_{rated} \geq 100$ kW.

- Federal R&D projects dealing with large WT's;
- Private manufacturers of large WT's; and
- Electric utilities that are installing large WT's.

The material discussed in this report summarizes key aspects of programs in which electric utilities have installed WT's. The major programs discussed are being conducted in the United States, Canada, and Denmark.

OBJECTIVES OF WT TESTS

The major objectives of the current large WT tests being conducted by electric utilities include the following:

- Obtain "hands-on" operational experience;
- Become familiar with WT technology and economics,
- Measure the impacts of machines on the network;
- Determine long-term machine reliability;
- Examine interconnection issues and problems; and
- Determine long-term operation and maintenance (O&M) costs.

The goal of some utility WT tests is to realize only a limited number of these objectives; the goal of others is to address all of them. The key elements in each utility test are described in the following sections.

KEY LARGE WT TESTS

Table 1 provides a summary of the 11 key utility large WT tests being carried out by 8 utilities in the U.S., Canada, and Denmark. The tests involve eight different WT's, although on first examination, it appears that there are only seven WT's. However, the two machines being tested by ELSAM, the Danish utility, have different rotor designs, although they have the same dimensions and configuration.

Only 3 of the 11 machines are vertical-axis wind turbines (VAWT's) of the Darrieus design. The remaining eight are two and three-bladed horizontal-axis wind turbines (HAWT's). Even though past studies, aimed at projecting the cost of energy from WT's, identified multi-megawatt machines as the most cost-effective approach, most of the test machines shown in Table 1 (7 of 11) fall in the medium-scale range (i.e., $100 \text{ kW} \leq P_{\text{rated}} < 1,000 \text{ kW}$). This is true primarily because it is far easier and less costly to meet test objectives by using medium-size machines.

TABLE 1. KEY LARGE WIND TURBINE TESTS BY ELECTRIC UTILITIES
(Exclusive of Federal R&D Efforts)

Utility	Wind Turbine Description				Date of First Utility Synchronization
	Manufacturer	Rated Power (kW)	Type*	Diameter m(ft)	
Southern California Edison Co.	Bendix	3000	H	50 (164)	Dec. 1981
	ALCOA	500	V	25 (82)	March 1981
Pacific Power and Light Co.	WTG Energy Systems	200	H	24.4 (80)	February 1981
Eugene Water and Electric Board (Oregon)	ALCOA	500	V	25 (82)	January 1981
Hydro-Quebec (Canada)	DAF-Indal Ltd. (Canada)	230	V	24.4 (80)	~April 1977
Pacific Gas & Electric Co.	Boeing Engineering and Construction	2500	H	91.5(300)	December 1981
Nova Scotia Power Co.	WTG Energy Systems	200	H	24.4 (80)	March 1981
U.S. Bureau of Reclamation/ Colorado River Storage Project	Hamilton Standard	4000	H	77.7(255)	~January 1982
	Boeing Engineering & Construction	2500	H	91.5(300)	December 1981
ELSAM (WT's at Nibe, Denmark)	Many (Unit A)	630	H	40 (131)	January 1980
	Many (Unit B)	630	H	40 (131)	August 1980

* H=Horizontal-Axis Wind Turbine; V=Vertical-Axis Wind Turbine

Tests in the United States

Many of those U.S. electric utilities that have good wind resources and are aggressively pursuing wind energy programs are testing, or planning to test, megawatt-scale WT's (i.e., Rated $\geq 1,000$ kW). The most noteworthy examples are two large investor-owned utilities; the Southern California Edison Company (SCE), which is conducting tests at the San Geronio Pass area of California (near Palm Springs) [1,2], and the Pacific Gas and Electric Company (PG&E), which is planning tests for the Solano County area approximately 60 km (40 miles) northeast of San Francisco.

The SCE test involves a unique three-bladed, 3-MW HAWT manufactured by the Bendix Corporation [7], and one of two three-bladed 500-kW Darrieus VAWT's commercially installed by the ALCOA Company [8]. In addition, the U.S. Bureau of Reclamation (a division of the Department of the Interior) is planning to test two megawatt-scale WT's in conjunction with the Colorado River Storage Project's hydroelectric facilities. This project will include a 4-MW Hamilton Standard WTS-4 machine [10] developed by the manufacturer primarily with its own funds. Hamilton Standard was supported by the Swedish Government in a similar 3-MW WT development program. In addition, the Bureau of Reclamation plans to install a commercial version of the MOD-2 WT; three such units have already been installed and are undergoing tests near Goldendale, Washington [11].

The Bureau of Reclamation project, although funded by the Federal Government, is discussed in this paper in conjunction with other electric utilities because the machines are being purchased on fixed-price, non-R&D contracts under the assumption that they have been fully developed and will require no further research and development.

The Bureau of Reclamation WT's will be tested under an interagency agreement between Reclamation and NASA, signed in May 1979. The agreement calls for the design, fabrication, installation, checkout, and operation of megawatt-size wind turbines. All funding for this project is being provided by the U.S. Department of the Interior, Bureau of Reclamation. NASA Lewis Research Center (LeRC) is responsible for project management from the design stage through initial operation.

After Reclamation has accepted the WT's from the contractor, it will operate and maintain the wind turbines, with support from the LeRC, for two years.

Two noteworthy tests using 200-kW WT's built by WTG Energy Systems are being carried out by the Pacific Power and Light Company (PP&L) of Portland, Oregon, and the Nova Scotia Power Corporation (NSP) of Halifax, Nova Scotia. The primary objective of each utility in conducting these tests is to obtain "hands-on" experience with WT's, and to determine whether any adverse interactions occur between the WT and the network. Because of the good wind resources in its service area, PP&L feels that a considerable number of WT's may eventually be installed by private installers, and thus they need early experience with wind machines to be prepared. NSP is also anxious to look at blade dynamic loads to gain an understanding of the correlation between these loads and blade life. To this end, NSP had WTG Energy Systems, Inc., install a limited number of strain-gage sensors on the blades.

The Eugene Water and Electric Board (EWEB), as part of the Central Lincoln Public Utility District in the Oregon/Washington area, has had the ALCOA Company install the only other commercially available 500-kW VAWT. At the present time, EWEB has not purchased the machine; it is awaiting satisfactory completion of acceptance tests by ALCOA. Like PP&L, the major reason for the WT installation is to allow EWEB to obtain "hands-on" experience with all aspects of the installation and evaluate network impacts of the machine. EWEB may go ahead with a more comprehensive test program in the future, but it has yet to formulate firm plans.

Canadian WT Programs

The Canadian large WT program, thus far, has concentrated on VAWT technology development and associated tests. Funding for the Canadian Government program has been provided by the National Research Council (NRC), with joint private industry funding provided by Hydro-Quebec, the provincial power authority in Quebec Province.

As shown in Table 1, the major Canadian large WT tests to date have been carried out on a two-bladed, 230-kW VAWT installed on the Magdalen Islands in the Gulf of St. Lawrence [12]. This machine has been used primarily as a research tool to obtain basic engineering data on the aerodynamic, mechanical, and electrical performance of a VAWT. As such, it has not seen a considerable amount of operating time. In the future, after most of the engineering data have been compiled, Hydro-Quebec plans to put the machine in an automatic operation mode to obtain long-term performance as well as operation and maintenance (O&M) data.

Danish WT Program

Over the past 40 years, approximately 20 large WT's have been installed and operated for extended periods in Denmark. Most of these machines were direct current (DC) versions installed in the 1940's before a full alternating current (AC) network had been installed in Denmark.

At the present time, the Danish Government is working jointly with ELSAM, the electric utility on the island of Jutland in NW Denmark, to test 2 three-bladed, upwind 630-kW machines in the town of Nibe [13]. Development and test activities associated with these machines represent the major large WT activity in Denmark [6]. As indicated in Table 1, the two machines (Nibe A & B) have the same size and power ratings. The major difference between the machines lies in their rotor design. The Nibe A machine employs fixed-pitch blades during operation (with tip flaps for shutdown, etc.) and supports the inner portion of each blade with in-plane and fore-and-aft stays. The Nibe B WT design includes fully pitchable blades (like most U.S. two-bladed large WT's) and supports their full bending moment.

These machines, installed approximately 200 meters (660 ft) from each other, will be comprehensively tested to verify both their engineering designs and mathematical models as well as to check for blade dynamics, sound, wake effects, cluster-coincident output, and site-specific issues such as environmental problems.

UTILITY INTERCONNECTIONS

The WT tests identified in Table 1 will be conducted with some machines tied strongly to a major transmission network, while others will be installed on distribution systems. Based on the relatively low level of power that is expected to be generated by each WT installation, no network problems are anticipated. Two examples of WT/utility interconnections are provided below.

Figure 1 shows how the two large WT's (up to 3.5 MW of power) will be strongly interconnected with the SCE transmission network. The one-line diagram shows that the output voltages from the two machines are different, but each will be stepped-up by transformers to a common 12-kV level and eventually to a 230-kV level for tie-in to the Devers substation approximately 600 meters (2000 ft) away. SCE is in the process of installing a 500-kV transmission line that will also tie in to the Devers substation. With this future expansion, SCE feels that additional WT capacity could easily be accommodated with no problems expected. The SCE installation is one of the strongest WT interconnections being tested thus far, and is not expected to lead to any adverse network interactions.

ORIGINAL PAGE 17
OF POOR QUALITY

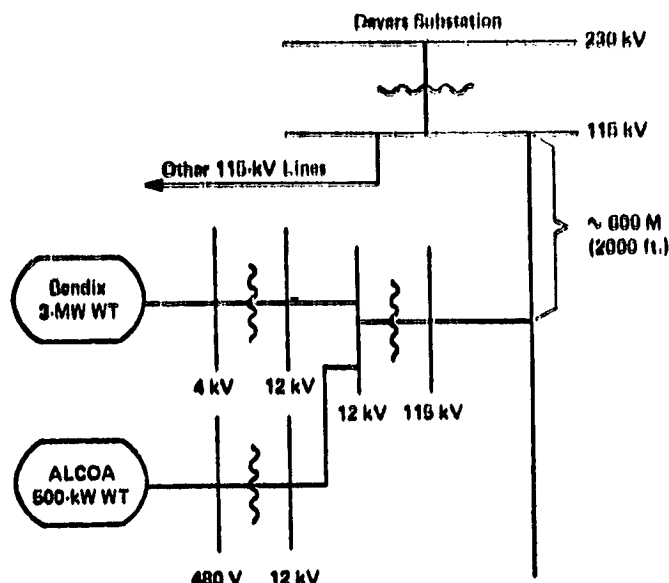

FIGURE 1. ONE-LINE DIAGRAM OF SOUTHERN CALIFORNIA EDISON WIND TURBINE INTERCONNECTIONS

Figure 2 is a pictorial representation of the 200-kW WTG Energy Systems, Inc., installation at Wreck Cove, Nova Scotia. The machine will provide power to the 25-kV distribution system which powers a 50-hp water pump close to the WT. The pump is used by NSP to manage the water source between two lakes; its waters ultimately help to serve two 100-MW hydro units. The NSP installation will be tied in to the distribution lines approximately 7 km (4 miles) from the 200 megawatts of hydropower. The 25-kV line serves very few loads in the region of the WT, except the pumps and a logging camp. No network problems are expected at present. In the future, NSP plans to install a new 3.5-MW low-head hydro unit 2.4 km (1.5 miles) from the WT and add power to the distribution system. The firm does not plan to vary the size of the distribution line, and anticipates no problems. This WT/utility interconnection although weaker than that at the SCE test site, is still not expected to pose a problem for the machine size being tested.

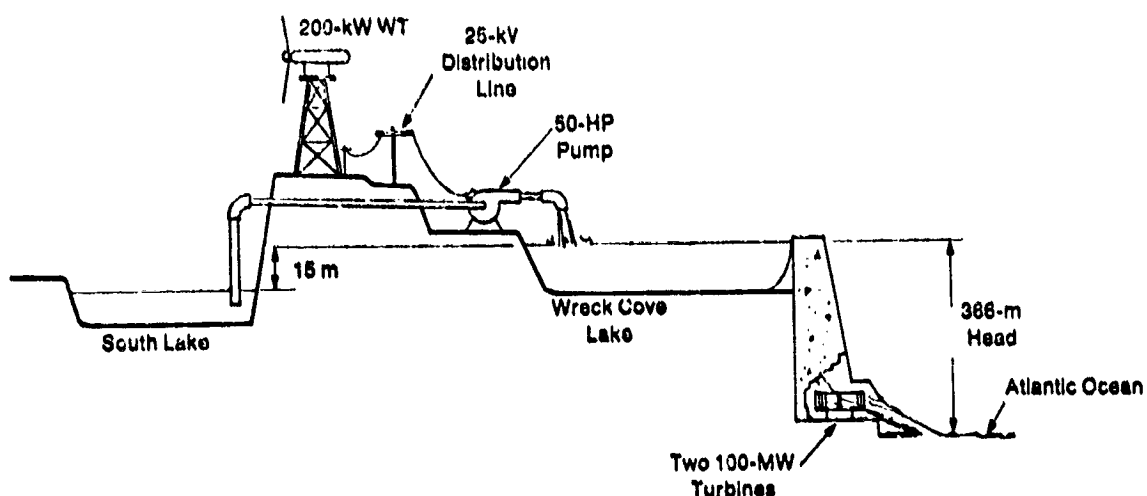

FIGURE 2. WTG ENERGY SYSTEMS, INC./NOVA SCOTIA POWER CO. INSTALLATION (WRECK COVE, N.S.)

ORIGINAL PAGE IS
OF POOR QUALITY

INSTRUMENTATION SUMMARY

The amount of instrumentation and the degree of sophistication in the data recording systems vary widely from one utility to the other. Those utilities that are embarking on WT installations as a major research project and have good wind resources in their region have invested considerable time and money to lay the foundation for a thorough understanding of the major technical, environmental, legal, and social issues surrounding WT installations. Other utilities are examining wind energy more superficially along with many other energy options. In this case, a more limited investment is being made and a more scaled-down data system is being installed.

Table 2 provides a synopsis of the instrumentation systems being employed in some of the key electric utility tests discussed. It should be noted that, in the SCE tests, the utility is planning to examine the output of approximately 22 sensors (including those for wind speed and direction at heights of 9.1 meters (30 ft) and 46 meters (150 ft)), while the manufacturers are also adding numerous sensors and recording data for detailed engineering analysis. Many of the manufacturers are also investing time and energy in instrumentation for these early models, because they are essentially engineering prototypes which will provide the basic data by which mathematical models and economic calculations will be verified.

TABLE 2. SUMMARY OF TEST INSTRUMENTATION AT
KEY ELECTRIC UTILITY LARGE WIND TURBINE TEST SITES

Utility	Number of Sensors	Data Logging		Data Sampling Rates
		System	Format	
Southern California Edison Co.	22*	Data Logger Spectrum Analyzer Oscillograph	Mag Tape Print/Plot Strip Charts	Every 15 minutes Periodic Periodic
Pacific Power & Light Co.	8	Handwritten	Log Sheet	Weekly
Hydro Quebec (Canada)	25	Oscillograph FM Recorder Minicomputer	Strip Charts Mag Tape Mag Tape	Periodic Periodic Not Available
Newa Scotia Power Co.	10	Microprocessor	Teletype	Every Hour
ELSAM (Denmark) (As of April 1981)	65	Minicomputer Recorder	Disc, Tape, Plot Strip Chart	5/sec Periodic

* Other WT mechanical sensors added by manufacturers

Sensors

All utility experiments will include integrated or instantaneous measurements of the following parameters:

- Power,
- Reactive power,

- Wind speed,
- Wind direction.

Some utilities will measure voltage, output current, power factor, generator speed, barometric pressure, and wet and dry bulb temperatures. In general, the U.S. electric utilities identified in Table 2 do not plan to measure detailed engineering data from the machine, such as torques, bending moments, temperatures, and vibration levels. Measurements of these parameters are being made by the manufacturers to verify their designs.

The WT development programs being conducted in Canada and Denmark include many sensors and comprehensive data recording schemes. These programs are being conducted jointly by the government and the host utility. The programs are aimed at accumulating both engineering data in the early test phases and long-term performance and O&M data later. Measurements of these parameters are being made by the manufacturers to verify their designs. Each project includes sensors to measure the above utility-oriented parameters plus strain gages and accelerometers to measure loads and vibrations.

Data Recorders

As shown in Table 2, the level of sophistication in data recording varies greatly from one utility to another. The following six types of data recording schemes have been employed with various test objectives in mind:

Oscillograph Recorder. High-speed oscillograph recorders are periodically employed to test the WT or network transient response to specific phenomena, such as wind gusts, utility tie-in to the network, WT cut-out from the network, and emergency shutdowns. The oscillograph can provide an accurate strip chart trace of key parameters--as long as the basic sensor and recorder responses are sufficient (i.e., adequate bandwidth) to capture the phenomenon of interest. Most oscillographs have a bandwidth of approximately 1 kHz, so the recorder is expected to capture most transient phenomena of interest to electric utilities.

Spectrum Analyzer. A spectrum analyzer can be employed periodically to measure the frequency content inherent in a transient phenomenon. Many of the phenomena analyzed are the same ones which will be portrayed by an oscillograph trace.

Data Logger or Minicomputer. A data logger is usually a low-speed digital sampling system that records the averages of key parameters over periods of 10 to 15 minutes. Generally, the parameters include average wind speed, energy produced, and reactive power consumed or delivered. In some cases, data loggers may use a microprocessor to carry out routine arithmetic operations before recording the data. Data loggers usually record the data on a magnetic tape or disc format. In many cases, a minicomputer that may perform control functions or complex computations can also be used as a data logger by outputting variables to a tape or disc recorder.

FM Recorder. The Canadian large WT test effort is employing a seven-track FM analog recorder to monitor the key variables for short intervals in a given test. The bandwidth of this type of data recording system varies with the speed of the tape recorder drive, but in all cases it should be adequate to monitor WT transient phenomena. If FM-recorded data have to be handled on a computer, they must first be filtered and then subjected to an analog-to-digital (A-to-D) conversion operation before being rewritten on computer-compatible tape.

Strip Chart Recorder. One- to eight-channel analog strip chart recorders of various types have been used in monitoring large WT performance. These recorders may be used to monitor higher speed phenomena (up to approximately 100-Hz bandwidth) or provide long-term monitoring of such parameters as wind speed, instantaneous power, or even blade loads. The benefit in using strip chart records is that test data are immediately available without further processing. They lend themselves well to limited visual examination of data, but are too cumbersome for use in the analysis of many records.

Hand-written Records. Periodically, hand-written records are used where no electronic outputs and no automatic data loggers are available. The written records are usually derived by reading elapsed meters, such as those that record elapsed operating time or cumulative energy generated. The data recorded are usually summary in nature.

RESULTS TO DATE

Table 3 provides a brief summary of the current status of the major large WT tests carried out by electric utilities in the United States, Canada, and Denmark. In addition Table 1 shows that, except for the Canadian VAWT program which began in 1977, all of the test machines began, or will begin, operation in the 1980 to 1982 time period. Many of these machines have been undergoing installation and checkout during the past year. This section provides a brief summary of the progress on each of the tests.

Southern California Edison Company (SCE) Tests

Bendix WT Tests. As shown in Table 3, the Bendix machine has operated very little over the past seven months, because SCE is being especially cautious in its test engineering approach [2]. The prototype machine employs many unique design features such as a variable-speed rotor, an hydraulically driven synchronous generator, and a tower which can be rotated to orient the machine into the wind. These features have never before been included in the design of a machine of such a size, and thus SCE is being very careful that no major or unmanageable problems arise because of its test approach.

At the beginning of the test phase, delays were experienced because of light winds. Further delays occurred later because of minor failures in the generator and its exciter circuit. During the early tests SCE installed a conventional automatic synchronizer, thus modifying its initial approach to controlling the machine's speed prior to coming on-line. Recently hydraulic leaks and problems with the data logger have

**ORIGINAL PAGE IS
OF POOR QUALITY**

caused minor delays. However, tests are proceeding, with a maximum power output of 960 kW measured thus far during approximately 15 hours of total synchronous operation.

**TABLE 3. STATUS OF KEY LARGE WIND TURBINE TESTS
BY ELECTRIC UTILITIES
(Exclusive of Federal R&D Efforts)**

Utility	Wind Turbine	Status	Hours of Operation	Maximum Power Produced (kW)	Energy Generated (MWh)
Southern California Edison Co.	Bendix (3000 kW)	Support Engineering Tests	~15	960	>2
	ALCOA (500 kW)	Reassembly Following Failure	N.A.	>500	N.A.
Pacific Power & Light Co.	WTG Energy Systems (kW 200)	Automatic Operation	~500	~400	N.A.
Eugene Water and Electric Board (Oregon)	ALCOA (500 kW)	Operation Ceased Awaiting Changes	N.A.	N.A.	N.A.
Hydro-Quebec (Canada)	DAF-Indal (230 kW)	Support Engineering Tests	~300	~200	N.A.
Pacific Gas & Electric Co.	Boeing Mod-2 (2500 kW)	Site Work	-	-	-
Nova Scotia Power Co.	WTG Energy Systems (200 kW)	Awaiting Partial Redesign	12	N.A.	N.A.
U.S. Bureau of Reclamation/ Colorado River Storage Project	Hamilton-Standard (4000 kW)	Site Work	-	-	-
	Boeing Mod-2 (2500 kW)	Site Work	-	-	-
ELSAM (Denmark) (as of April 1981)	Nibe A (630 kW)	Rework Following "1000 hr" Inspection	845	~650	152
	Nibe B (630 kW)	Automatic Operation	453	~800	53

N.A. indicates data not available

ALCOA WT Tests. The first synchronous operation of the ALCOA 500-kW VAWT at the SCE site occurred early in March 1981. The machine operated for a few hours (less than 10) before it was partially destroyed during checkout tests on April 3, 1981. The machine was damaged when an overspeed condition occurred that resulted from a complex series of events. The machine reached a rotational speed of 60 rpm before destruction; its normal design speed is 41 rpm. The whole series of events leading up to the failure occurred in 39 seconds. The main reasons for the failure, according to the manufacturer, included:

- An omission in the WT's computer control program that was to bring the WT to a safe stop with its service brake at the proper time.
- A sudden line voltage drop of 25 percent which occurred when the WT generator came on-line; the drop was caused by excessive transformer impedance. The voltage drop also caused the WT controller to malfunction temporarily.

- The aerodynamic efficiency of the Darrieus rotor being higher than ALCOA models had predicted. The ALCOA machine components (viz., the brakes, attachments, and such) were not built strong enough to withstand the higher loads.

Pacific Power and Light Company (PP&L) Tests

At the present time, the PP&L tests of the 200-kW HAWT built by WTG Energy Systems, Inc. (WTG) are proceeding in a relatively smooth manner. The machine began automatic operation in June 1981. Prior to this, the WT was not operated for a short period while a problem was being addressed. WTG had identified a design problem in which transient wind gusts were generating excessively high transient output-power fluctuations. WTG was initially concerned that the associated fluctuating system torques might be damaging to the system.

In June 1981, PP&L and WTG agreed to begin testing the WT in an automatic test mode. In the meantime, WTG is exploring the possibility of attenuating the rotor torque variations caused by wind gusts by installing an induction generator instead of the present synchronous unit.

Eugene Water and Electric Board (EWEB) Tests

The ALCOA 500-kW VAWT, installed at an Agate Beach site within the EWEB district, operated for a very few hours before it was shut down. EWEB is awaiting word on a fix to the problem that arose on the similar unit that was installed at the SCE test site. Present plans indicate that the machine design will be modified in the fall of 1981 to include a new gear box. At the same time a lower rotor rpm (approximately 36 rpm) will also be employed. The machine is expected to be operational early in 1981.

Hydro-Quebec Tests

The DAF-Indal, Ltd., 230-kW VAWT installed in the Magdalen Islands has been operated periodically in support of engineering tests. It has only operated approximately 100 hours since being repaired early in 1980--following a failure in 1978, and has not as yet achieved its full output power of 230 kW. Much of the detailed test data from the machine has not yet been evaluated by the National Research Council of Canada, because of manpower and funding limitations.

Pacific Gas and Electric Company (PG&E) Tests

The PG&E MOD-2 2,500-kW WT is expected to be installed at the Solano County, California, site in the fall of 1981, and tests on the WT are expected to commence in early 1982, following the successful completion of acceptance tests. PG&E has plans for a comprehensive data acquisition system, as well as plans for detailed engineering, sound, television interference, and environmental tests.

U.S. Bureau of Reclamation Tests

Hamilton Standard WT Tests. The first 4-MW WT (Model WTS-4) to be built by Hamilton Standard experienced a few minor schedule delays, but in general is proceeding toward first rotation early in 1982 [10]. Fiberglass blades for the machine are being fabricated at Hamilton Standard's unique blade-winding facility in East Granby, Connecticut. Many of the early prototype engineering problems that might be experienced on this first unit are expected to be addressed in the similar 3-MW machine (Model WTS-3) being built for the Swedish Government for delivery late in 1981.

Boeing MOD-2 WT Tests. Many of the parts for the MOD-2 WT were ordered by Boeing in 1979-1980 as part of the DOE-funded cluster tests that ultimately led to the installation of three MOD-2 WT's at a site near Goldendale, Washington. Early in the DOE program, it was tentatively planned that a fourth MOD-2 WT would be installed and tested. Therefore, many of the parts were available for the Bureau of Reclamation installation. Their availability resulted in very rapid progress on the machine installation. The only design change on the MOD-2 WT was to double the strength of the yaw drive system in order to accommodate loads at the higher cut-out wind speed of 26.8 m/s (60 mph). At the present time, it appears that the machine will undergo its first network synchronization in the early-to-mid-fall 1981 period.

ELSAM WT Tests

The Nibe A & B WT's have been subjected to an arduous series of tests from the time of their initial installation until their full automatic operation approximately one year later. The tests are being carried out by ELSAM, the Danish electric utility for Gotland in northwest Denmark. During this period, personnel from both ELSAM and the Risø National Laboratory in Denmark conducted an exhaustive series of startup, shutdown, safety system, and engineering tests to determine whether the machine would perform at an acceptable level. Numerous technical problems were overcome during this period, the primary ones being associated with the control computers and the hydraulic systems. During the tests in which the machines were providing power to the 20-kV ELSAM network, no voltage or frequency problems were identified.

The summary performance data for each machine, as shown in Table 3, are current as of April 1, 1981. The following is a brief account of the results of tests conducted during the past year.

ORIGINAL PAGE IS
OF POOR QUALITY

Nibe A WT. The Nibe A WT went into automatic operation in August 1980, and by November 1980 it had run for 845 hours. At that time it underwent a "1000-hour" inspection, which revealed a number of small problems; e.g., oil leaks, corrosion, and bearing deterioration. However, the major finding was that many welds in key, highly stressed locations had been improperly made. Many of these welds were made in the area of the blade stays. However, the machine has undergone a major rework on the key welded joints and should be back in service in July 1981.

Nibe B WT. The Nibe B WT, which employs three fully pitchable blades, has been operating satisfactorily since it began full automatic operation in February 1981. Since then, it has logged 453 hours of operating time, and no major problems have been identified thus far.

OTHER WIND ENERGY VENTURES

There are two other major types of wind energy ventures that could lead to substantial new wind energy installations in utility systems. These include (1) DOE-funded R&D programs, and (2) private wind energy installations funded by independent investors.

The major DOE-funded R&D effort at the present time is the 7.5-MW MOD-2 WT cluster at Goldendale, Washington [11] which came on line late in 1980 and early 1981. Comprehensive and practical WT performance, dynamic, and operational data are expected to be completed at that test site. Table 4 provides a brief description of the installation and also identifies the other major private ventures being undertaken in the United States.

TABLE 4. OTHER MAJOR WIND TURBINE CLUSTER TESTS
IN CONJUNCTION WITH ELECTRIC UTILITIES

Project Developer	Utility	Wind Turbine	Number of Wind Turbines	Installed Capacity (MW)	Date of Expected Completion
U.S. Department of Energy	Bonnaville Power Administration	Boeing Mod-2 (2.5 MW)	3	7.5	May 1981 (Operational)
Windfarms Ltd.	Hawaiian Electric Co.	Hamilton Standard WTS-4 (4 MW)	20	80	~ 1985
U.S. Windpower, Inc.	Public Service Company of New Hampshire	U.S. Windpower (30 kW)	20	0.6	December 1980 (Operational)
Windfarms, Ltd.	Pacific Gas and Electric Co.	N.A.	146	350	~ 1985-90

N.A. indicates data not available

Because of the favorable tax credits that are permitted to private wind energy ventures, and the appealing legal environment provided by the Public Utilities Regulatory Policy Act (PURPA) of 1978, many private companies have been created. Their objective is to install WT's and then sell the electricity they generate back to the utilities. These

companies, backed by funds provided by investors, have often been referred to as "windfarmers," because the WT configurations planned in these ventures often take the form of clusters or "farms" of many machines. The output of these clusters will be fed directly into the transmission and distribution networks of the local electric utility. People in the industry expect that the ownership of some WT clusters may eventually be acquired by local utilities after the clusters have exhausted most of their tax advantages to the investor.

The three major investor-funded WT ventures in the United States are briefly summarized in Table 4. The only private venture that is currently operating is the U.S. Windpower 600-kW cluster located on Crotched Mountain in southern New Hampshire. No formal test results are publicly available on that project. The two Windfarms Ltd. projects identified in Table 4 are in various stages of planning, negotiation, and design--with full operation expected by the mid-1980's, when the present advantages of the federal energy tax credit are scheduled to expire.

SUMMARY

At the present time, many electric utilities with good wind resources in their respective regions are proceeding to test pilot WT installations. The overall goal of these early installations is to provide utilities with "hands-on" experience, so that they will be prepared to manage wind energy as a new energy source when it becomes economically attractive. At the same time, many utilities are attempting to develop a technical understanding of WT's so that they can effectively interact with private WT investors and developers who may attempt to sell wind-generated electricity to the utility.

However, no large WT installations have advanced beyond the engineering prototype test stage. In this stage of development many typical hardware and software design problems are being identified and remedied. Therefore, the test results thus far do not alter current projections for attractive wind turbine performance and economics when the technology matures and production machines become available.

ACKNOWLEDGEMENT

The work discussed in this paper has been funded by the Advanced Power Systems Division of the Electric Power Research Institute (EPRI). The authors wish to acknowledge the comments and support of the EPRI Project Manager, Dr. Frank R. Goodman, and the assistance of Mr. Frederick R. Madio and Mr. Rusi F. Patel of Arthur D. Little, Inc.; and a subcontractor, Mr. Henry W. Zaininger Engineering Company.

REFERENCES

1. Fung, K.T., Scheffler, R.L., and Stolpe, J., "Wind Energy - A Utility Perspective," Presented at IEEE Summer Power Meeting, July 1980, Southern California Edison Company, P.O. Box 800, Rosemead, California 91770.

2. Wehrey, M.G., "Utility Experience with Two Demonstration Wind Turbine Generators," Workshop on Large Horizontal-axis Wind Turbines, July 28-31, 1981, NASA Lewis Research Center, Cleveland, Ohio 44135, July 1981.
3. Frederick, W.A., Miller, J.A., and Pfluger, J.E., "A Fully Inter-connected Wind System," Proceedings of the Workshop on Economic and Operational Requirements and Status of Large-scale Wind Systems, March 26-30, 1979, DOE Report No. CONF-790352, June 1979.
4. Vachon, W.A., "Large Wind Turbine Generator Performance Assessment, Technology Status Report No. 1," EPRI Report AP-1317, January 1980.
5. Vachon, W.A., "Large Wind Turbine Generator Performance Assessment, Technology Status Report No. 2," EPRI Report AP-1641, December 1980.
6. Vachon, W.A., "Large Wind Turbine Generator Performance Assessment, Technology Status Report No. 3," Report to the Electric Power Research Institute on EPRI Project RP 1348-1, June 1981.
7. Rybak, S.C., "Description of the 3-MW WTS-3 at San Geronio Pass, California," Workshop on Large Horizontal-axis Wind Turbines, July 28-31, 1981, NASA Lewis Research Center, Cleveland, Ohio 44135, July 1981.
8. Ai, D.K., "ALCOA Wind Turbines," Workshop on Large Wind Turbine Design Characteristics and R&D Requirements, April 24-26, 1979, DOE Report CONF-7904111, April 1979.
9. Watts, A.W., "System Verification Units for Wind/Hydroelectric Inter-gration," Workshop on Large Horizontal-axis Wind Turbines, July 28-31, 1981, NASA Lewis Research Center, Cleveland, Ohio 44135, July 1981.
10. Bussolari, R.J., "Status of the 4-MW WTS-4 Wind Turbine," Workshop on Large Horizontal-axis Wind Turbines, July 28-31, 1981, NASA Lewis Research Center, Cleveland, Ohio 44135, July 1981.
11. Axell, R.A., and Woody, H.B., "Status of the 7.5-MW MOD-2 Cluster at Goldendale, Washington," Workshop on Large Horizontal-axis Wind Turbines, July 28-31, 1981, NASA Lewis Research Center, Cleveland, Ohio 44135, July 1981.
12. South, P., and Watts, A., "Magdalen Islands VAWT Field Test," Proceedings of the Workshop on Economic and Operational Requirements and Status of Large-scale Wind Systems, March 26-30, 1979, DOE Report No. CONF-790352, June 1979.
13. Pederson, B.M., and Nielsen, P., "Description of the Two Danish 630-kw Wind Turbines, Nibe-A and Nibe-B, and Some Preliminary Test Results," Third International Symposium on Wind Energy Systems, Copenhagen, Denmark, Published by BHRA Fluid Engineering, Cranfield, Bedford MK43 OAJ, U.K, August 1980.