

SPT

Activities in Planetary Geology

(NASA-EP-179) ACTIVITIES IN PLANETARY GEOLOGY FOR THE PHYSICAL AND EARTH SCIENCES (National Aeronautics and Space Administration) 183 p HC A19/MF A01 N82-33789 Unclas CSCI 08G G3/42 35106

for The Physical and Earth Sciences

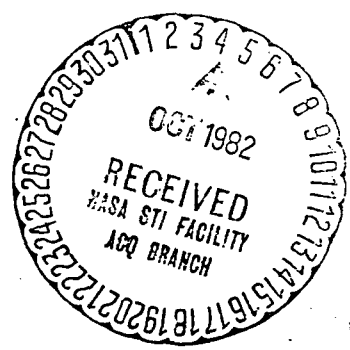

THE PLANETS AND EARTH'S MOON

	Mercury	Venus	Earth	Mars	Jupiter	Saturn	Uranus	Neptune	Pluto	Earth's Moon	
Physical Characteristics	Mean distance from Sun in millions of km in astronomical units	57.9 0.38	108.2 0.72	149.6 1.00	227.9 1.52	778.3 5.20	1,427 9.54	2,869.6 19.18	4,496.6 30.07	5,900 39.44	Distance from Earth: 384,400 km
	Equatorial diameter in km in Earth diameters	4,880 0.38	12,104 0.95	12,756 1.00	6,787 0.53	142,800 11.19	120,000 9.41	51,800 4.06	49,500 3.88	3,000 (?) 0.24 (?)	3,476 0.272
	Mass compared to Earth	0.055	0.815	1.000	0.108	317.9	95.2	14.6	17.2	0.025 (?)	0.0123
	Volume compared to Earth	0.06	0.88	1.00	0.15	1,316	755	67	57	0.013 (?)	0.0203
	Density in gram/cm ³ (water = 1.00)	5.4	5.2	5.5	3.9	1.3	0.7	1.2	1.7	1.00 (?)	3.34
Dynamic Characteristics	Period of revolution	88.0 d	224.7 d	365.26 d	687 d	11.86 y	29.46 y	84.01 y	164.8 y	247.7 y	Around Earth: 27.32 d
	Period of rotation at equator	58 d 15 h 52 m	-243 d*	23 h 56 m	24 h 37 m	9 h 50 m	10 h 14 m	-10h 49m*	12 - 20 h	6 d 9 h 20 m	27.32 d
	Mean orbital velocity in km/sec	47.90	35.05	29.80	24.14	13.06	9.65	6.80	5.43	4.74	1.02
	Obliquity	<28°	3°	23°27'	23°59'	3°05'	26°44'	82°05'	28°48'	120° (?)	6°41'
	Orbit eccentricity	0.206	0.007	0.017	0.093	0.048	0.056	0.047	0.009	0.248	0.055
Surface Characteristics	Surface gravity compared to Earth	0.37	0.88	1.00	0.38	2.64	1.15	1.17	1.18	0.45 (?)	0.16
	Escape velocity (km/sec)	4.2	10.3	11.2	5.0	61	37	22	25	?	2.4
	Most abundant atmospheric gasses	None	Carbon dioxide	Nitrogen, oxygen	Carbon dioxide	Hydrogen, helium	Hydrogen, helium	Hydrogen, helium, methane	Hydrogen, helium, methane	None detected	None
	Mean temperature (°C) at visible surface at cloud tops	350 d -170 n --	480 -33	22 --	-23 --	-- -150	-- -180	-- -210	-- -220	-230 (?) --	134 d -153 n --
	Atmospheric pressure near surface in millibars	10 ⁻⁹	90,000	1,000 (sea level)	6	**	**	?	?	?	None
	Number of confirmed natural satellites	0	0	1	2	16 and rings	17 (?) and rings	5 and rings	2	1 (?)	0

*Minus sign indicates retrograde rotation
 **No apparent surface
 y = years
 d = days
 h = hours
 m = minutes
 n = night

2019 *[Handwritten signature]*

Activities in Planetary Geology

for The Physical
and Earth Sciences

NASA

National Aeronautics and
Space Administration
Washington, DC 20548
1982

PREFACE

This book is the outgrowth of a short course in Planetary Geology, conducted in the Spring of 1976 for high school science instructors from Fairfax County, Virginia, organized by Peter H. Schultz† and Ronald Greeley, then of the University of Santa Clara, California. William Johnson, Fairfax High School Earth-Science Instructor, and Lee Ann Hennig, Fort Hunt High School Planetarium Director, were participants in the short course and agreed to take a primary role in preparing a previous edition of this book entitled *Curriculum Guide in Planetary Geology for Earth Science Instruction*. Using material from the short course, Johnson and Hennig tested some of the exercises in the classroom. From their experience, conversations with other participants, and use at Arizona State University, the exercises were modified for incorporation within this edition. Greeley and Schultz edited and guided the various drafts of the original curriculum guide; D'Alli enlarged and edited that guide into the present version.

We recognize the need for continued classroom testing of the material included in this book. User comments and suggestions for improvements are solicited and welcomed.

Richard D'Alli & Ronald Greeley, 1982
Department of Geology
Arizona State University
Tempe, Arizona 85287

†Current address: Lunar and Planetary Institute
3303 NASA Road 1
Houston, Texas 77058

TABLE OF CONTENTS

PREFACE	ii
INTRODUCTION	iv
SPECIAL NOTE TO THE TEACHER	vi
UNIT ONE: THE LUNAR PHASES	1
UNDERSTANDING THE PHASES OF THE MOON	2
UNIT TWO: ACTIVITIES IN PLANETARY CRATERING	19
IMPACT CRATERING.....	20
COMPARING CRATERING PROCESSES	40
IMPACT CRATERING.....	54
UNIT THREE: ACTIVITIES IN AEOLIAN PROCESSES	63
AEOLIAN PROCESSES: MARTIAN WIND TUNNEL	64
UNIT FOUR: PLANETARY ATMOSPHERES	79
CORIOLIS EFFECT	80
CORIOLIS EFFECT: DEMONSTRATION I	89
CORIOLIS EFFECT: DEMONSTRATION II	93
STORM SYSTEMS	97
UNIT FIVE: THE GEOLOGICAL MAPPING OF OTHER PLANETS	111
PHOTOGEOLOGIC MAPPING OF THE MOON: THE PROVINCES	112
PHOTOGEOLOGIC MAPPING OF THE MOON: STRATIGRAPHY.....	116
THE PLANETS IN STEREO.....	124
LANDFORM MAPPING: MOON, MERCURY AND MARS	131
GEOLOGIC FEATURES OF MARS.....	138
APPENDIX	166
HOW TO ORDER NASA MOTION PICTURES	167
HOW TO ORDER NASA PUBLICATIONS.....	168
A NOTE ABOUT PHOTOGRAPHS	169
SUGGESTED CORRELATION OF TOPICS.....	170
SELECTED GLOSSARY FOR PLANETARY GEOLOGY.....	172

INTRODUCTION

Contemporary earth science courses generally include a modest introduction to the solar system. The justification is reasonable enough: the challenge of the earth sciences is to understand the natural processes of the terrestrial environment, and the sun and planets are part of that total environment. But there are more compelling arguments for an

expanded, perhaps central, role that curriculum planners should consider giving to planetary science. Those arguments, a few of which are outlined below, have inspired NASA to conduct short courses in lunar and planetary science for earth science teachers at the secondary and college level. This book is a revised edition of the results of one of those short courses.

THE PLANETARY PERSPECTIVE

Few, if any, natural phenomena can ever be understood in a figurative vacuum, isolated from their relationship with other natural phenomena. The planet Earth, even taken as one, enormous entity, is no exception. The natural forces that have driven Earth's evolution and shaped its surface are most likely operating elsewhere in the solar system. It is the job of the earth scientist to recognize those forces on all planets and explain why they are manifested on our world in ways that seem familiar, and on other worlds in ways that may not.

The earth scientist is also concerned with earth materials, the building blocks of this planet. If there has been one illuminating by-product of space exploration, it has been the emergence of a unifying vision of the birth and growth of planets. Pictures of the planets sent back by spacecraft strongly suggest the fraternity of the inner planets. Rocks and soil brought back from the Moon bear remarkable similarity, and of course, important differences, to earth materials. Even spacecraft pictures of the jovian satellites, planets themselves by right of size, have astounded scientists with their exotic, but recognizable surface materials. The American geologist T. C. Chamberlin (1843 - 1928) once wrote that when approaching a scientific problem, it was most important to maintain several—not just one—working hypotheses. Prior to space

travel by man and machines there were, in fact, only terrestrial examples of planet-making materials and processes. Now it has become possible to take that all-important, scientific step of devising general theories from a collection of working hypotheses. The multiple working hypotheses come from the scenes of extraterrestrial environments.

A major goal of science is prediction. Once primitive, generalized theories are formulated, experiments are designed to test the theories by their predictions. Some experiments that could address the problems of earth scientists simply cannot be performed on Earth, in a laboratory or otherwise, because of their monumental proportions. What could be more illustrative, elegant, or challenging than to consider the other planets as great experiments running under conditions differing from those on Earth? The result may be not only to gain insight into planetary scale problems, but also to escape the somewhat limited and often myopic earthbound view of nature.

Along these same lines, there is further reason to incorporate planetology into the study of earth science. The earth scientist is painfully aware that the dynamic processes active on Earth today have virtually wiped clean the very record of their own history. However, relicts and indirect evidence of our

own deep past exist in various states of preservation on other planetary surfaces. A common tactic used by scientists to understand complex systems is to study simpler, analogous systems. While the Earth is a complex, turbulent, and sometimes delicately balanced system, the other planets may represent stages in the evolution of that system that, for one reason or another, have been arrested in their development. To avoid a touch of geocentric parochialism it must be said that the Earth may well be a simpler case of more complicated but as yet unstudied planets.

Finally, the study of the Earth and planets on a grand scale is not without practical benefits. Better analysis of the characteristics and motions of the atmosphere, sea, and exposed solid crust has proven to be of economic and cultural value. Meteorologists, for example, have been observing Earth's weather since

Ben Franklin's day. What has been missing is another model, another atmosphere to study, where the variables are different, but the dynamics are as definitive. We just may have found those requirements in the atmospheres of Venus, Mars, Jupiter, and Saturn.

We are living in a time of revolutionary discoveries in earth science. Although we lack the historical perspective to say for certain, it is possible that the fundamental work in earth and planetary sciences over the last 20 years will be likened to Galileo turning the first telescope toward the heavens. From a scientific standpoint, and perhaps also from that of a curriculum planner, earth science is a special case of the more general planetary or solar system sciences. This then, if for no other reason, is the motivation to study other worlds, to learn more about that celestial neighborhood in which we occupy a small, but life-sustaining place.

ABOUT THIS BOOK

Science education has been and will continue to be an integral part of any scientific endeavor. When the National Aeronautics and Space Administration was created by act of Congress in 1958, its charter required the agency to ". . . provide for the widest practicable and appropriate dissemination of information concerning its activities and the results thereof." Part of that responsibility includes introducing young students to the scientific and practical results of space exploration. This volume has been designed to do just that.

In the spring of 1976 a "Planetary Geology Short Course" was conducted by NASA in cooperation with the University of Santa Clara and the Fairfax County, Virginia, Public School System. The participants were earth science teachers and planetarium directors from the northern Virginia school system. The objective of the short course was to

introduce the teachers to activities in (and sources of information about) planetary geology, which could be used in their classrooms. Specific topics were discussed by noted scientists who specialize in lunar and planetary geology, climatology, geochemistry, and other related fields. Many of the activities in this book are adaptations of actual exercises used in the short course. The course was directed by Dr. Ronald Greeley, presently at Arizona State University, and Dr. Peter Schultz of the Lunar and Planetary Institute in Houston.

The activities in this book have been designed either to supplement or to introduce topics usually encountered in earth science courses. Consistent with the rationale outlined in the preceding paragraphs, most activities deal with new concepts in planetary geology, but, when generalized to include terrestrial

processes, can illustrate broad problems in the earth sciences. The exercises have not been keyed to any particular text; rather, each one can and should address concepts as independent units. There is no implied preferred sequence of presentation or level of sophistication based on the order of appearance of the activities.

Depending upon the persuasion of the instructor, most activities can be adapted to almost any level of instruction, theoretically from elementary school to undergraduate, by the appropriate modification of the questions and adjustment of expectations for answers. A list of suggested correlations of activities with topics commonly covered in earth science courses has been included for the convenience of the instructor.

ACKNOWLEDGEMENTS. Many people deserve credit for the development of this book. Innumerable students in short courses and regular session classes, as well as NASA scientist-contributors, so freely gave their time, thoughts and valuable criticisms. Typesetting and production were done by Carol Rempfer. Sue Selkirk and Mary Milligan provided the artwork and drafting. Bill Knoche spent endless hours in the dark-room preparing the figures. Lisa Halliday assisted the editors while a NASA Planetary Geology Intern. Finally, we gratefully acknowledge Stephen E. Dwornik and Joseph M. Boyce, Planetary Geology Program, NASA Headquarters, Washington, D. C., without whose continuing support and sponsorship neither the short courses nor this book would have been possible.

SPECIAL NOTE TO THE TEACHER

This publication is not a conventional activity workbook. There are several important points that instructors should bear in mind while using it.

Each activity is printed twice, once in a format suitable for classroom use, and again in the same format with answers and suggestions inserted in the appropriate blanks. This eliminates the need to refer to an answer key listed either in a separate publication or in a

compact addendum. It should also be a convenience for the teacher.

No copyright laws apply to this publication. Duplication or reprinting of any or all materials are strongly encouraged.

It is our hope that this book can be a valuable resource in teaching the physical, Earth, and space sciences.

Planetary Geology Program
Arizona State University
Tempe, Arizona 85287

ACTIVITIES IN
PLANETARY GEOLOGY
FOR
THE PHYSICAL AND EARTH SCIENCES

THE LUNAR PHASES

The activities presented in this unit deal with observing the changing lighting conditions on the Moon. The Sun appears to rise and set over the lunar surface just as it does on Earth, but with a major difference: instead of the average twelve hours between sunrise and sunset there are nearly two weeks in one lunar day! After performing the simulations on the following pages, it should be easier to visualize how that might look on the Moon, and why that translates into phases of the Moon as seen from Earth.

(Instructor's Note)

There are three levels of questions in the activity: those plainly numbered, those with a single asterisk, and those with a double asterisk. This is an attempt on the part of the authors to judge the difficulty of the questions. Those without an asterisk should be the least difficult, those with a double asterisk, the most difficult.

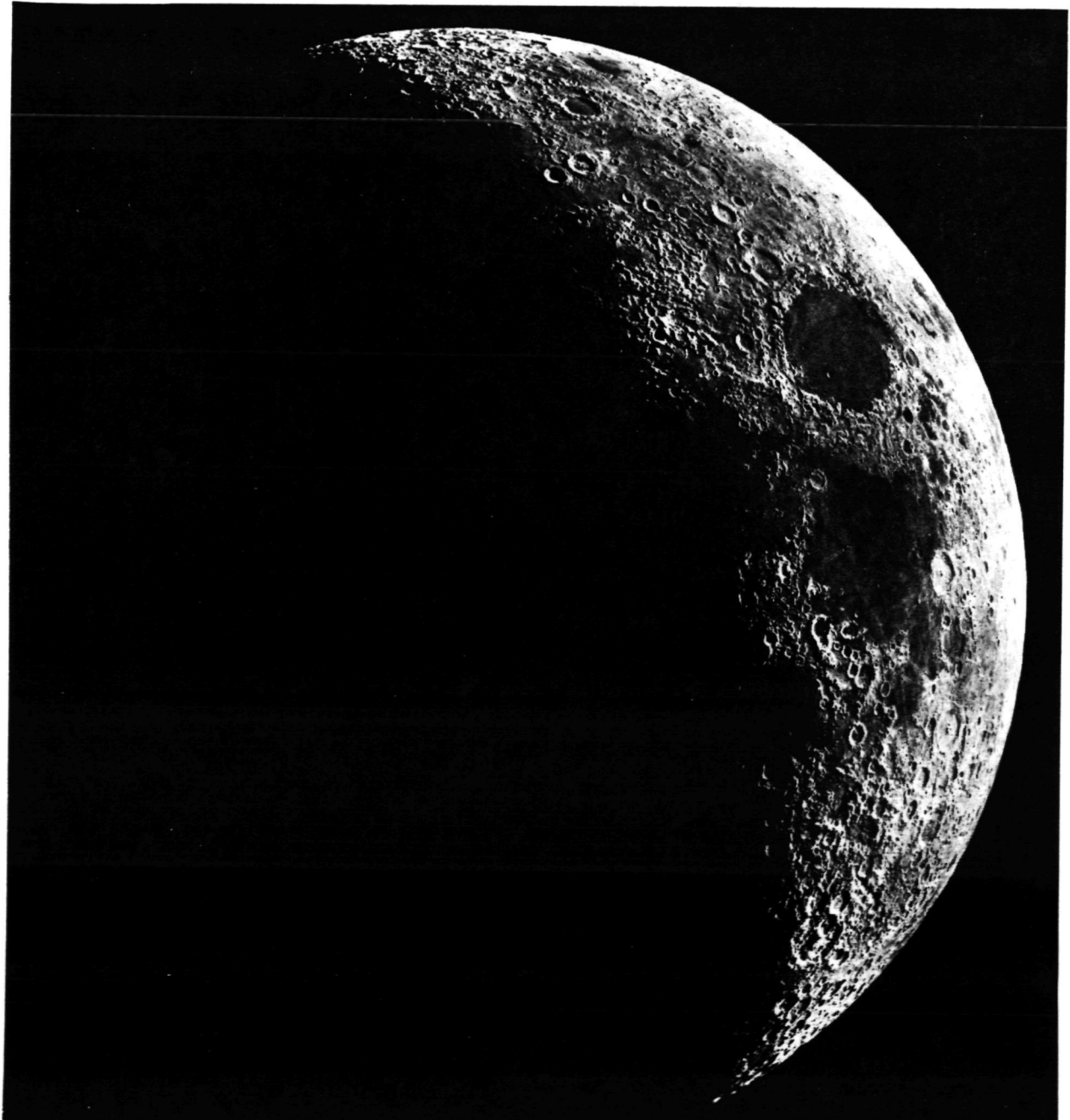

UNDERSTANDING THE PHASES OF THE MOON

OBJECTIVES

1. To simulate the phases of the Moon with classroom models.
2. To demonstrate the effects of the special revolution and rotation rates of the Moon.
3. To generalize these findings to the other planets.

MATERIALS

1. Floodlamp in bowl-shaped socket/reflector
2. Sphere, ball or globe close to or larger than 20 cm (8") in diameter
3. Grease pencil or chalk to mark the sphere
4. Pencil and paper
For use with optional advanced activity:
5. 35 mm camera, preferably with at least a 135 mm telephoto lens
6. Plus-X or Panatomic-X black and white film and processing materials
7. Tripod
8. Protractor, preferably with a string-and-weight plumb line

Many legends have been passed down through history to explain the daily changes in the fraction of the face of the Moon that is illuminated. Of course scientists have known for hundreds of years that the revolution of the Moon around the Earth in space causes these changes in illumination, or *phases of the Moon*.

The Moon, just as everything else we see in our natural environment, is illuminated by light from the Sun. We see it because it reflects that light back to Earth.

Since the Moon revolves around (orbits) the Earth, it comes between, but not always in front of, the Sun and the Earth once a month, and similarly moves behind, but not always directly behind, the Earth. You will now demonstrate how this creates phases.

PROCEDURE AND QUESTIONS

1. One student should sit in a chair and represent the Earth. Fasten the floodlamp to some stable object one meter (3') above the floor and 2 meters (6') away, pointing toward the chair. *It is recommended that a student not hold the lamp, because it will get very hot.* Another student, holding the sphere about one meter above the floor, will walk in a circle counterclockwise around the chair about one meter away, stopping at every position marked by a circle in the diagram.
2. Turn on the floodlamp. The student in the chair (Earth) should draw in the nine open circles (positions of the Moon) on the diagram how the Moon appears to be illuminated.

ORIGINAL PAGE
BLACK AND WHITE PHOTOGRAPH

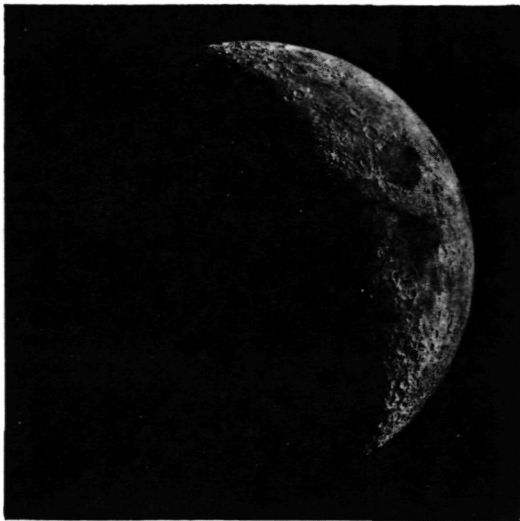

The Moon about 4 days old. This phase is called the waxing crescent. Waxing means "growing," while any phase between new and first quarter is crescent shaped.

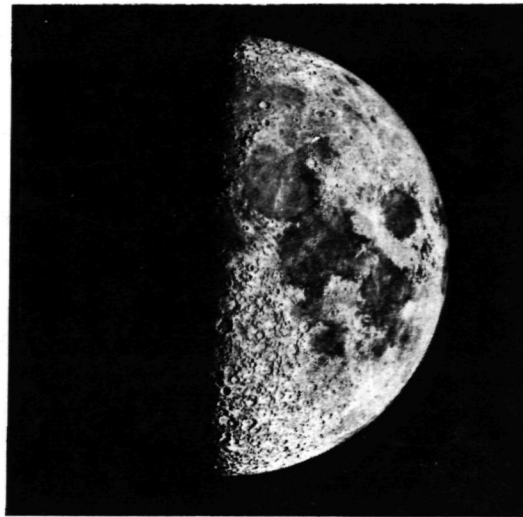

The Moon 7 days old. This is the first quarter phase that occurs when exactly one-half of the Earth-facing (nearside) hemisphere of the Moon is illuminated. The bright half faces the western horizon.

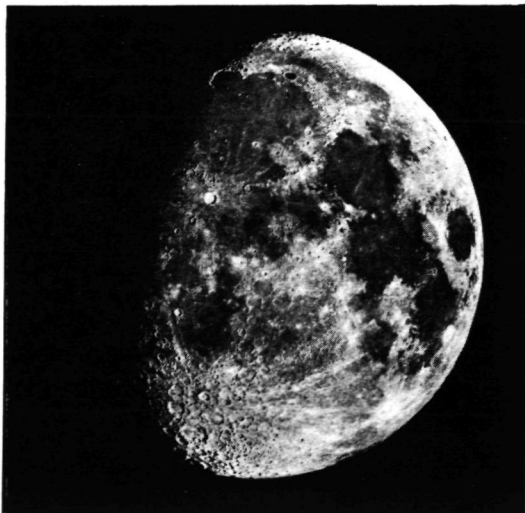

The Moon a little more than 10 days old. This is known as the waxing gibbous phase. Gibbous means any fraction of illumination between half (first or last quarter) and full.

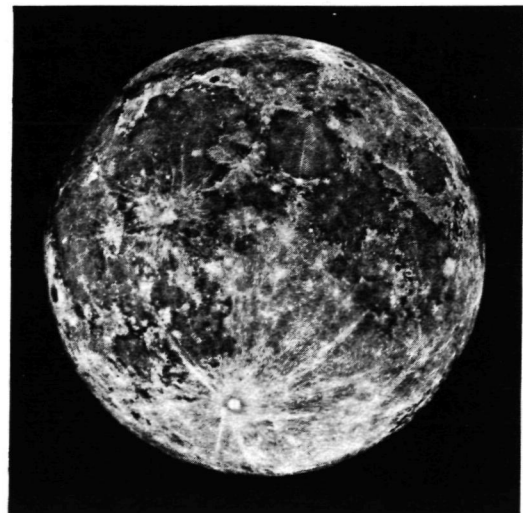

The Moon 14 days old. This is the familiar full Moon. The exact moment of full Moon occurs when the Moon is precisely opposite the Sun in the sky. Notice that the craters are not as distinct but the ray patterns show up very well.

Fig. 1.1: Telescopic photographs of the Moon. The total length of time required for the Moon to go through one complete cycle, called the synodic month, is 29½ days.

ORIGINAL PAGE
BLACK AND WHITE PHOTOGRAPH

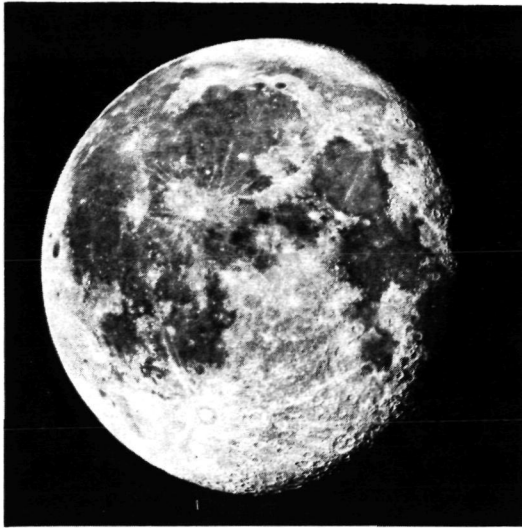

The Moon 18 days old. This is called the waning gibbous phase. Waning means "shrinking." Any phase between full and last quarter is known as waning gibbous.

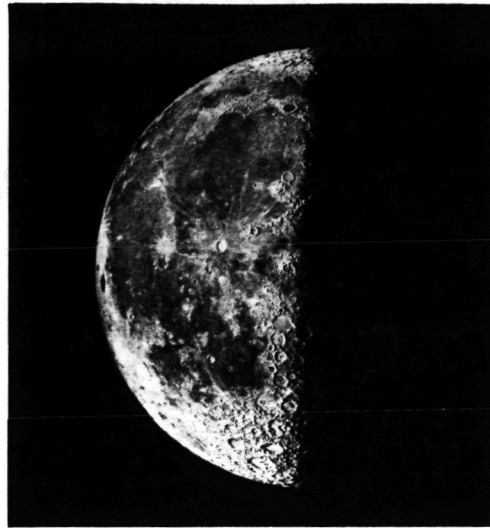

The Moon 22 days old. This is the last quarter Moon. Exactly half of the Earth-facing hemisphere is lighted. The bright half faces the eastern horizon.

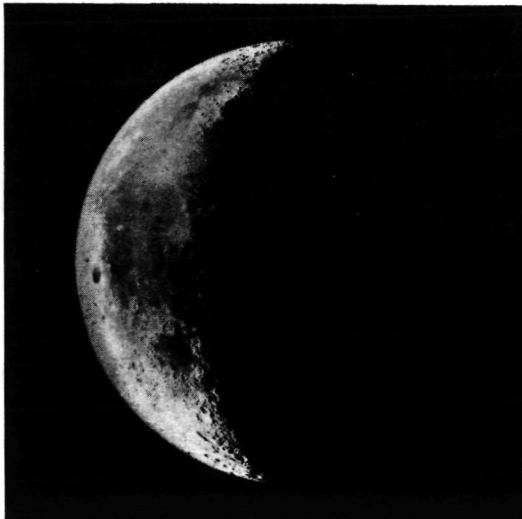

The Moon a little more than 24 days old. This is an example of the waning crescent phase.

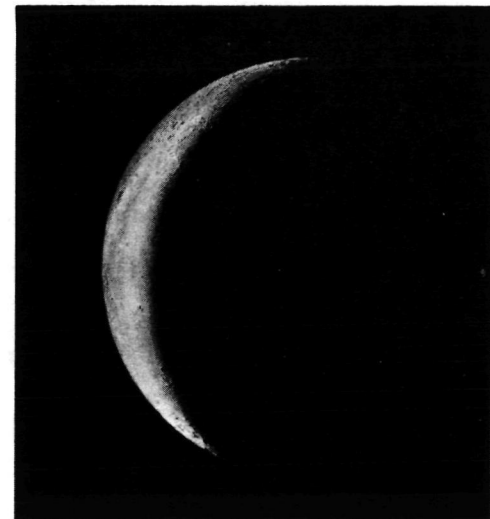

The Moon 26 days old. This is also a waning crescent occurring just before new Moon, beginning a new cycle.

(Photos courtesy of E. A. Whitaker, University of Arizona.)

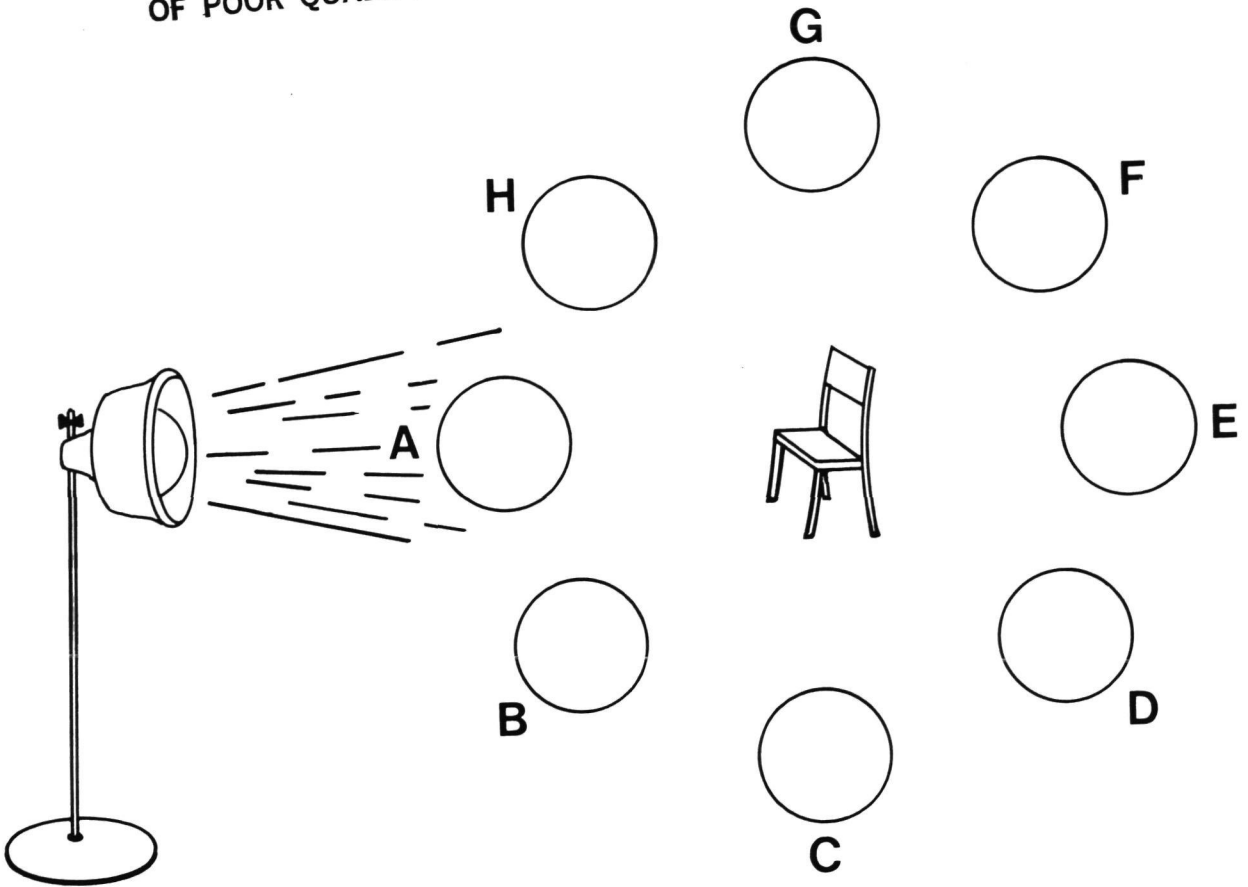

3. Study the photographs of the Moon in Fig. 1.1 and 1.2. Write the name of the phase represented by each of the positions of the "Moon" in the preceding diagram.

A. B. C.

D. E. F.

G. H.

4. How long does it take for the Moon to complete one orbit of the Earth?

.....

5. How long is it between new moon and full moon?

.....

6. How long is it between full moon and either quarter moon?

.....

*7. Is only one-quarter of the surface of the Moon illuminated during the first-quarter moon?

*8. Look at the picture of the full Moon in Fig. 1.1. Why do you think some places on the face of the Moon are brighter than other places?

*9. What does the "quarter" refer to in the label first-quarter?

** 10. Would you expect the reflected spectrum of moonlight to match the spectrum of sunlight? Why or why not?

11. You can see from the photographs in Fig. 1.1 that the Moon always keeps the same features pointed toward the Earth. Mark the sphere (Moon) on its equator with a large X. The student holding the sphere should line up the X with some object in the classroom. Then he should walk around the chair (Earth) keeping the X constantly lined up with the distant object. This represents an orbiting Moon that does *not* spin (rotate). The student representing Earth should describe what he sees in the space below. Discuss.

12. Now the student holding the Moon should walk around the chair always keeping the X pointed toward the chair (Earth).

13. How fast must the Moon rotate so that the same features are always seen on Earth?

*14. Is the far side (the face we never see) ever illuminated? If you think it is, then when and why?

ORIGINAL NAME
BLACK AND WHITE PHOTOGRAPH

- ** 15. Propose a reason for the Moon always keeping the same face toward Earth (period of rotation = period of revolution).



Fig. 1.2: A most unusual new moon. Because the orbit of the Moon is not level with the Earth's orbit around the Sun (the Moon's orbital plane is inclined 5° to the ecliptic), the new moon does not always line up precisely between the Earth and Sun. But periodically it does, casting a shadow down to the Earth's surface. This produces the solar eclipse shown here. Photo by Richard D'Alli.

UNDERSTANDING THE PHASES OF THE MOON

(Instructor's Key)

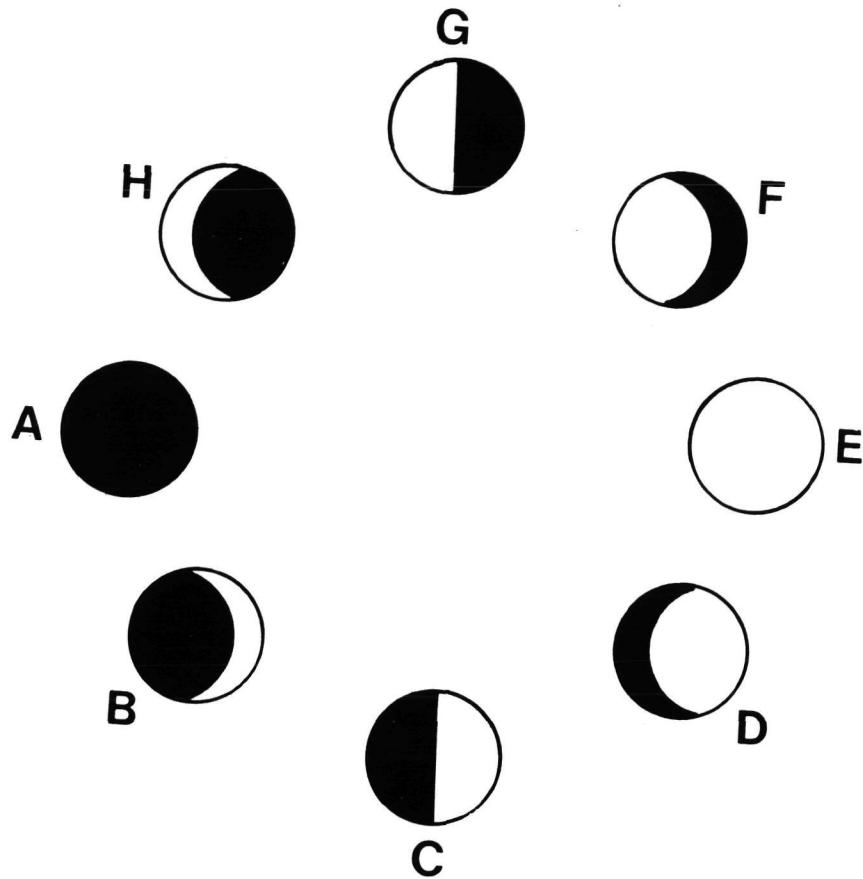

3. Study the photographs of the Moon in Fig. 1.1 and 1.2. Write the name of the phase represented by each of the positions of the "Moon" in the preceding diagram.

A. *new moon*

B. *waxing crescent*

C. *first quarter*

D. *waxing gibbous*

E. *full*

F. *waning gibbous*

G. *last quarter*

H. *waning crescent*

4. How long does it take for the Moon to complete one orbit of the Earth?

27 1/3 days

5. How long is it between new moon and full moon?

about 14 days

6. How long is it between full moon and either quarter moon?

about 7 days

ORIGINAL PAGE
BLACK AND WHITE PHOTOGRAPH

- *7. Is only one-quarter of the surface of the Moon illuminated during the first-quarter moon?

No.

- *8. Look at the picture of the full Moon in Fig. 1.1. Why do you think some places on the face of the Moon are brighter than other places?

The dark patches, or lunar maria, are depressions filled with basaltic lavas which are inherently darker than the predominantly anorthositic rocks of the cratered highlands. The maria are also significantly smoother than the rugged cratered highlands (topographic control of reflection).

- *9. What does the "quarter" refer to in the label first-quarter?

It is one quarter of the way through its phase cycle (or orbit).

- **10. Would you expect the reflected spectrum of moonlight to match the spectrum of sunlight? Why or why not?

No; although the Moon is illuminated by a continuous, white-light spectrum, its reflectance spectrum is controlled by the chemical and physical properties of the surface rocks.

11. You can see from the photographs in Fig. 1.1 that the Moon always keeps the same features pointed toward the Earth. Mark the sphere (Moon) on its equator with a large X. The student holding the sphere should line up the X with some object in the classroom. Then he should walk around the chair (Earth) keeping the X constantly lined up with the distant object. This represents an orbiting Moon that does *not* spin (rotate). The student representing Earth should describe what he sees in the space below. Discuss.

The Earth should see the X appear to rotate around the Moon's axis.

12. Now the student holding the Moon should walk around the chair always keeping the X pointed toward the chair (Earth).

13. How fast must the Moon rotate so that the same features are always seen on Earth?

It must rotate at the same angular speed with which it revolves; that is, it must take the same time to complete one spin on its axis as one revolution about the Earth.

- *14. Is the far side (the face we never see) ever illuminated? If you think it is, then when and why?

Yes. It goes through phases also. During new moon as defined on Earth, the far side is fully illuminated as seen from the Sun.

ORIGINAL PAGE
BLACK AND WHITE PHOTOGRAPH

- **15. Propose a reason for the Moon always keeping the same face toward Earth (period of rotation = period of revolution).

One suggestion has been a gravitational lock with Earth since the Moon's center of mass is offset from the center of figure toward Earth.

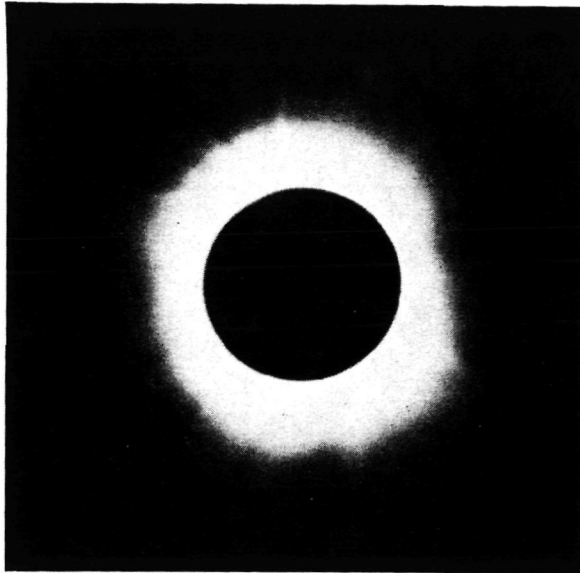

Fig. 1.2: A most unusual new moon. Because the orbit of the Moon is not level with the Earth's orbit around the Sun (the Moon's orbital plane is inclined 5° to the ecliptic), the new moon does not always line up precisely between the Earth and Sun. But periodically it does, casting a shadow down to the Earth's surface. This produces the solar eclipse shown here. Photo by Richard D'Alli.

UNDERSTANDING THE PHASES OF THE MOON

(Intermediate Activity)

PROCEDURE AND QUESTIONS

1. Remove the chair. The student representing Earth should stand up. You will now simulate the motions of Earth and Moon day by day. Turn on the floodlamp. Place the Moon near the lamp, but do not block the light. The student representing the Earth should stand so that the Moon and Sun are immediately to his left. The Earth (student) should then begin a slow turn on his heels (rotation) counterclockwise. *In the same time it takes for the Earth to complete one rotation*, the Moon (student) should advance about 20 cm counterclockwise in a circle still 1 meter from the Earth. The student representing Earth should now describe exactly what he sees by using the following questions as a guide.
2. When you begin this activity, it is 6 am on the day of the new moon. How do you know this?
.....
.....
3. In which direction has the Moon moved in the sky relative to the Sun?
.....
4. REPEAT THE INSTRUCTIONS FOR 6 MORE EARTH ROTATIONS.
In what phase is the Moon now?
.....
5. What time does this phase of the Moon rise above the horizon? (Hint: You can tell this from the position of the Sun.)
.....
6. REPEAT THE INSTRUCTIONS FOR 7 MORE EARTH ROTATIONS.
What time does the full moon rise?
.....
7. What time does the full moon set?
.....

8. Fill in the blanks in the table below:

PHASE	MOONRISE	MOONSET
New	6 am	6 pm
1st Quarter		
Full		
Last Quarter		

FOR DISCUSSION AT ALL LEVELS

9. When Galileo first turned his telescope toward the heavens in 1609, he wrote: *The Mother of Love rivals the phases of Cynthia: that is, Venus imitates the phases of the Moon.*[†] This fundamental discovery can be restated to say that all planets nearer to the Sun than the Earth go through phases as seen from Earth. Why? The outer planets (Mars and beyond) never show a complete set of phases to us. Why?

[†]From Omer *et al.*, *Physical Science: Men and Concepts*, University of Florida Press, copyright 1969.

UNDERSTANDING THE PHASES OF THE MOON

(Intermediate Activity)

(Instructor's Key)

PROCEDURE AND QUESTIONS

1. Remove the chair. The student representing Earth should stand up. You will now simulate the motions of Earth and Moon day by day. Turn on the floodlamp. Place the Moon near the lamp, but do not block the light. The student representing the Earth should stand so that the Moon and Sun are immediately to his left. The Earth (student) should then begin a slow turn on his heels (rotation) counterclockwise. *In the same time it takes for the Earth to complete one rotation*, the Moon (student) should advance about 20 cm counterclockwise in a circle still 1 meter from the Earth. The student representing Earth should now describe exactly what he sees by using the following questions as a guide.
2. When you begin this activity, it is 6 am on the day of the new moon. How do you know this?
Both the Moon and Sun are exactly on the eastern horizon (assuming the observer is "looking south").
3. In which direction has the Moon moved in the sky relative to the Sun?
The Moon has drifted behind or moved eastward from the Sun.
4. REPEAT THE INSTRUCTIONS FOR 6 MORE EARTH ROTATIONS.
In what phase is the Moon now?
It should be in first quarter, 90° eastward (behind) the Sun.
5. What time does this phase of the Moon rise above the horizon? (Hint: You can tell this from the position of the Sun.)
Noon.
6. REPEAT THE INSTRUCTIONS FOR 7 MORE EARTH ROTATIONS.
What time does the full moon rise?
Six pm or sunset.
7. What time does the full moon set?
Six am or sunrise.

8. Fill in the blanks in the table below:

PHASE	MOONRISE	MOONSET
New	6 am	6pm
1st Quarter	12 noon	12 midnight
Full	6 pm	6 am
Last Quarter	12 midnight	12 noon

FOR DISCUSSION AT ALL LEVELS

9. When Galileo first turned his telescope toward the heavens in 1609, he wrote: *The Mother of Love rivals the phases of Cynthia: that is, Venus imitates the phases of the Moon.*[†] This fundamental discovery can be restated to say that all planets nearer to the Sun than the Earth go through phases as seen from Earth. Why? The outer planets (Mars and beyond) never show a complete set of phases to us. Why?

The inner planets periodically pass between the Sun and Earth and continue in their orbits behind the Sun. When viewed from Earth (outside their orbits), the inner planets show us their dark hemispheres when they pass between the Earth and Sun. They are fully illuminated when they pass behind the Sun (see diagram). The planets outside Earth's orbit will always appear nearly fully illuminated since the Sun is always "to our back" as we look outward.

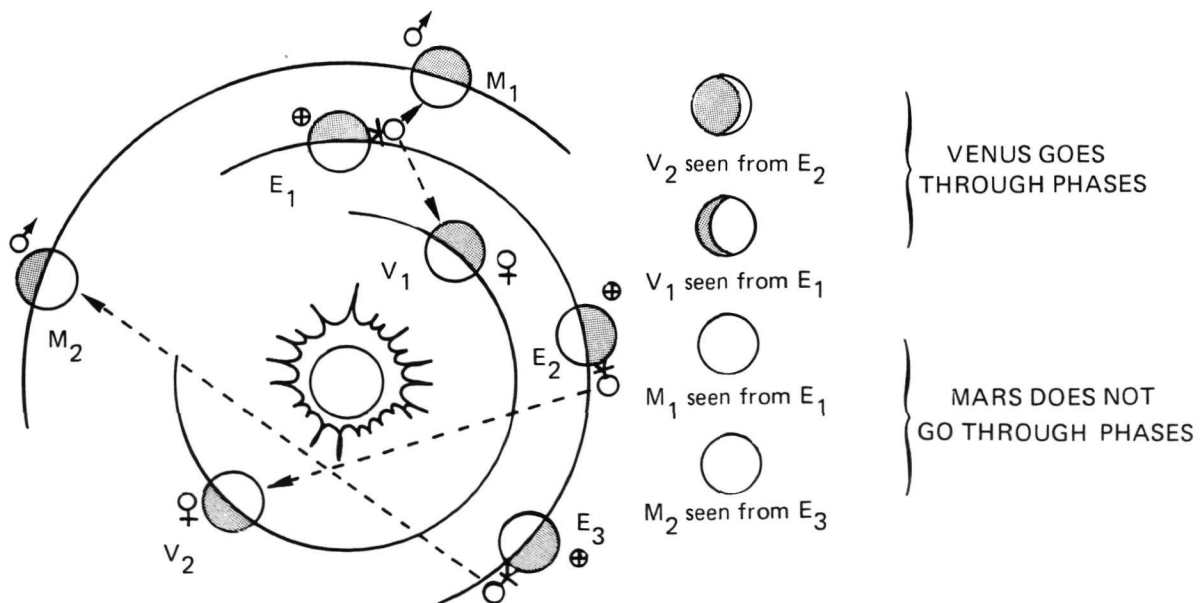

[†]From Omer *et al.*, *Physical Science: Men and Concepts*, University of Florida Press, copyright 1969.

**ORIGINAL PAGE IS
OF POOR QUALITY**

UNDERSTANDING THE PHASES OF THE MOON

(Optional Activity)

PROCEDURE AND QUESTIONS

- Each student should actually observe the Moon through at least two complete cycles. The student should go outside to a safe location with an unobstructed view of the eastern horizon at the same time (say, 9:00 pm) every night. Beginning on the night of a new moon[†], the student should record the date, time, sketch the phase, and estimate the approximate altitude in degrees above the horizon. A table similar to the one below should be kept:

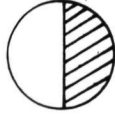
DATE	TIME	SKETCH OF PHASE	ALTITUDE
Oct. 28, 1979	9:05 pm		about 45° above western horizon
Oct. 29, 1979	8:55 pm	cloudy (Moon not visible)	---

[†]You can get the date of the new moon from several sources: certain calendars, newspapers, almanacs, local museums, or your school or public library.

** (Optional Advanced Activity)

- A common impression is that the harvest moon, the large orange-colored full moon rising after an autumn sunset, is quite a bit bigger than the normal full moon. To test this notion, a student can photograph the Moon to make an unbiased record of its size.
- Set a 35-mm camera on a tripod on level ground facing the eastern horizon. The camera should be loaded either with Plus-X or Panatomic-X black and white film. A long focal length lens should be used. A 135-mm telephoto lens will suffice, although longer lenses are preferable. When the harvest moon is just above the horizon, make several exposures at settings close to and including the ones suggested in the table at the end of the activity. Wait about 4 hours. Aim the camera at the Moon and take several exposures as before now that the Moon is high in the sky. Develop the film; prints are not necessary. Using the most accurate scale available (a vernier caliper or finely divided metric rule), measure the size of the Moon's image on the negative.

**3. Can you detect a noticeable difference in image size between the harvest moon at moonrise and the same full moon later in the same night?

**4. Explain your results.

**5. What could cause the impression of a larger-than-normal harvest moon?

6. Suggested camera settings for photographing the full moon:

FILM	ASA SPEED	APERTURE	SHUTTER SPEED
Plus-X	125	f/16	1/500
Panatomic-X	32	f/ 5.6	1/125

UNDERSTANDING THE PHASES OF THE MOON

(Optional Activity)

(Instructor's Key)

- **3. Can you detect a noticeable difference in image size between the harvest moon at moonrise and the same full moon later in the same night?

There should be no detectable difference in size.

- **4. Explain your results.

The effect is an illusion.

- ** 5. What could cause the impression of a larger-than-normal harvest moon?

When the Moon is low on the horizon, its size can be compared with normal objects (trees, buildings, etc.) and appears quite large. When high in the sky, there are no close reference objects. It is then difficult to judge its size or compare it to the apparent size near the horizon.

6. Suggested camera settings for photographing the full moon:

FILM	ASA SPEED	APERTURE	SHUTTER SPEED
Plus-X	125	f/16	1/500
Panatomic-X	32	f/ 5.6	1/125

ACTIVITIES IN PLANETARY CRATERING

The following activities demonstrate the fundamental principles of impact crater formation. They are only simulations. True impact or volcanic craters are formed under conditions that exceed by far your ability to duplicate in the classroom. The physical variables do not scale upward in a simple way to compare with actual crater formation. However, the appearance of the crater models formed in these activities closely approximates that which is observed on planetary surfaces. The activities, therefore, are excellent for stimulating discussions on the lunar landscape, terrestrial craters and the evolution of planetary surfaces.

In the impact cratering experiments the student will study the craters created when objects of different masses and travelling with different velocities strike a target of fine sand. There are several important concepts to be learned:

1. There is a relationship between the velocity and mass of the "meteorite" and the size of the crater.
2. Craters can be divided into distinct zones: floor, wall, rim, ejecta materials and rays.
3. The relative age of surface features can be estimated using craters.

The activity on comparing cratering processes is a natural extension of the impact experiments. Because the majority of craters found on planets are produced by impacts, it is logical to perform that activity first.

On Earth explosion craters are formed by large-scale events such as nuclear explosions. With the exception of subtle differences in the ejecta patterns, explosion craters are to some degree analogs for impact craters. Craters can also be formed during volcanic eruptions. These craters are typically seen either on volcanic summits or on the flanks of volcanic cones. Volcanic craters have also been identified on the Moon, Mars, and most recently as active volcanoes on Io, one of the satellites of Jupiter. An excellent activity to follow these laboratories is the showing of the film "Controversy over the Moon." See HOW TO ORDER NASA MOTION PICTURES in the appendix.



Fig. 2.1: The best preserved meteorite crater in North America is the Barringer Crater at the Meteor Crater Registered National Landmark, Winslow, Arizona. It was created between 20,000 and 30,000 years ago by a nickel-iron meteorite weighing about 150,000 metric tons. The crater is 1.2 kilometers in diameter and 120 meters deep, but the meteorite was probably only about 30 meters in diameter, or roughly about the size of the building on the edge of the crater. The reason such a relatively small meteorite created such a large crater is because the meteorite was moving at about 15 kilometers per second (9 miles each second) before impact. Coupled with its large mass, the high velocity of the meteorite gave it a huge amount of kinetic energy. All that kinetic energy released in a matter of seconds during impact can excavate quite a large hole in the ground. (Because of the low speeds and masses used in this activity, the craters you create will be only slightly—2 to 4 times—larger than the projectile ("meteorite") used.)

IMPACT CRATERING

OBJECTIVES

1. To model impact craters in the laboratory.
2. To recognize the conditions that control their size and appearance.
3. To understand their influence on the geology of a planet.

MATERIALS

1. A tray or very strong box at least 2 feet on a side and about 4 inches deep
2. A large supply of extremely fine sand, 80-100 μm if possible
3. Four identical marbles or small ball bearings
4. One steel ball bearing about $\frac{1}{2}$ inch in diameter
5. Three solid spheres about 1 inch in diameter, all the same size but made of different materials (example: glass, plastic, steel; or glass, wood, aluminum; etc.)
6. Meter stick
7. 10 cm ruler
8. Kitchen tea strainer
9. Two dark colors of dry tempera paint (powder): e.g. red and blue
10. Toy slingshot
11. Safety glasses or goggles
12. Large pack of assorted marbles
13. Laboratory balance to weigh projectiles
14. Watering or sprinkling can or plant mister

Impact craters are those craters formed when meteorites strike the surface of a planet. They are found on all of the *terrestrial planets*, on Earth's Moon, and on many of the satellites of the outer planets. Impact craters are not easily recognized on Earth because of the intense weathering and erosion that wears away its surface. On the Moon over 80 percent of the surface looks much the same as it did over 3 1/2 billion years ago, heavily cratered and very rugged. About half of the surface of Mars is also ancient, but preserved *cratered terrain*. Although only 40 percent of Mercury has been photographed by spacecraft, over two-thirds of its surface is heavily cratered.

Various geological clues and studies of the lunar rocks returned by the Apollo missions indicate that about 3.9 billion years ago asteroid-size chunks of matter were abundant in the solar system. This was a time of intense bombardment of the young planets, affecting Earth by breaking up and modifying parts of its crust. Mountain building, plate tectonics, weathering and erosion have largely removed all traces of the Earth's early cratering period. But the near absence of weathering on the Moon has allowed the evidence of this ancient period (considered to be the last stage of *planetary accretion*) to be preserved.

The Mariner 9 and Viking spacecraft pictures demonstrate the importance of both impact craters and wind erosion on the surface of Mars. In this activity you will begin your study of craters created by projectiles (meteorites) of different masses, moving at different speeds and striking a target (planet surface) of sand.

PART A: THE FORMATION OF CRATERS

The following experiments deal with the relationships among projectile mass, velocity and crater size. Impacts involve the transfer of energy from the projectile to the target (ground). **Kinetic energy** (energy of motion) is defined as: $K.E. = 1/2 mv^2$, where m = mass and v = final velocity.

PROCEDURE AND QUESTIONS

- The Importance of Mass.** Pour sand into the tray to a depth of at least 3 inches. Smooth the surface of the sand with the edge of the meter stick. Divide the surface into two equal areas. Weigh each projectile and record the mass in the table. From a height of 2 meters (6') drop each of the large spheres (three different types) into one area. Carefully measure and record the diameter of the craters formed by the impacts without disturbing the sand. Fill in the table below:

OBJECT	TYPE OF OBJECT	MASS OF OBJECT	CRATER DIAMETER
Sphere #1		gm	cm
Sphere #2		gm	cm
Sphere #3		gm	cm

- Look at your results carefully. Which sphere created the largest crater?
.....
- What is the *only* difference in the way each crater was made?
.....
- Each sphere represents a meteorite. What can you say about the importance of the *mass* of a meteorite in making a crater?
.....
- Did any sphere appear to fall faster than the others? Did it really? Why or why not?
.....
.....

6. **The Importance of Velocity.** Locate the four identical marbles. Weigh each marble and record its mass below. Drop one marble into the second area from a height of 10 cm and another from 2 meters. The third projectile should be launched from the slingshot extended 23 cm (9"), the fourth, from the slingshot extended 36 cm (14"). Without disturbing the sand, carefully measure the crater diameter.

CAUTION: THE SLINGSHOT IS A POTENTIALLY HAZARDOUS DEVICE. USE EXTREME CAUTION WHEN IT IS EMPLOYED IN THIS ACTIVITY. UNDER NO CIRCUMSTANCES SHOULD IT BE AIMED HORIZONTALLY.

Complete the following table:

	VELOCITY	MASS	CRATER DIAMETER
Marble 1	140 cm/sec	gm	cm
Marble 2	626 cm/sec	gm	cm
Marble 3	1000 cm/sec†	gm	cm
Marble 4	3000 cm/sec†	gm	cm

† approximate

7. Did you measure any difference in the diameters of the craters?

8. What is the *only* difference in the way each crater was made?

9. In this case each marble (meteorite) had the same mass. What did dropping two marbles from different heights and propelling the other two accomplish?

10. Besides diameter do you notice any other difference in appearance among the craters?

- *11. Which do you think is more important in creating larger craters, more mass or more velocity? Why?

* 12. Calculate the kinetic energy † upon impact for each marble in Question 6.

	<i>KE</i>	
Marble 1	ergs
Marble 2	ergs
Marble 3	ergs
Marble 4	ergs

* 13. Examine the results in Part A. Summarize your conclusions regarding the size, mass, and velocity of impacting projectiles, and its *kinetic energy* (indicated by the size of the resulting crater).

.....
.....

PART B: THE STRUCTURE OF A CRATER

1. Remove all projectiles from the sand and smooth the surface well. Again divide the tray into two areas. With your instructor's help sprinkle a very fine layer of dry tempera color over the sand using the tea strainer. The layer of colored powder should cover the surface just enough to conceal the white sand.

CAUTION: WEAR THE GOGGLES AND BE SURE THAT NO GLASS OR BREAKABLE MATERIALS ARE IN THE VICINITY OF THE ACTIVITY.

2. Use the slingshot to shoot the 1/2" steel sphere vertically into the sand. DO NOT DISTURB THE CRATER IN THE FOLLOWING STEPS.
3. Draw two pictures, one in each box on the next page, of the crater, one looking down from above (map view) and one as seen from *ground level* (elevation or side view).

† If mass is measured in grams and velocity in cm/sec, then kinetic energy is given in ergs, or gm X cm²/sec². For comparison the energy equivalent of one calorie of heat is 4.2 X 10⁷ ergs.

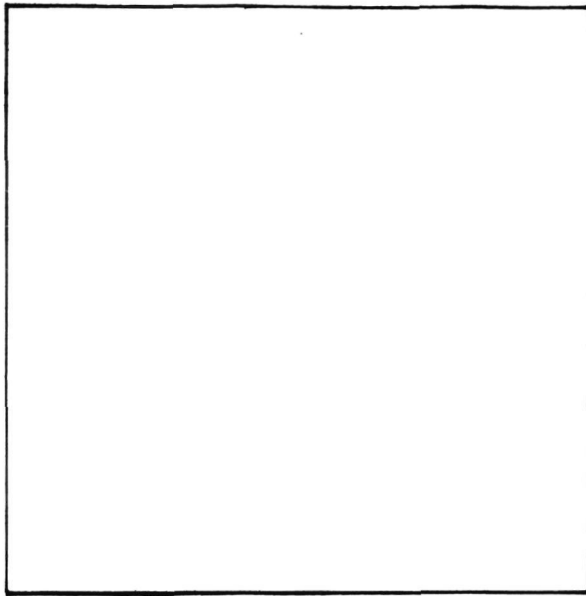

Map View

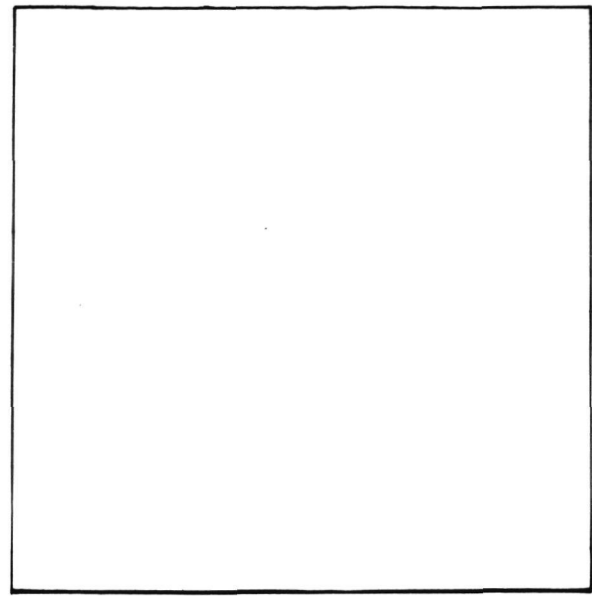

Side View

This is an ideal example of a small fresh crater.

4. Label the drawings with the words rim, ejecta and impact crater. Notice the sharp details of the crater.
5. Where do you find the thickest ejecta?
.....
6. What do you think caused the crater rim to form?
.....
- *7. The colored powder represents the most recent sediment deposited on a planet's surface. Any material beneath the top layer must have been deposited at an earlier time (making it physically older). If you were examining a crater on the Moon, where would you probably find the oldest material? Why do you think so?
.....
.....

PART C: CRATERING AS GEOLOGIC PROCESS

1. In the second area create another crater as in Part B. Locate the large pack of assorted marbles. Drop each marble in the pack from an arbitrary height into the second area so that each one impacts at a different speed. Be careful to drop the marbles **near but not directly on top of** the crater formed by the slighshot method. Watch the process very carefully as you do it.

2. How does the appearance of the original crater from Part B change as you continue to bombard the area?

3. What do you think is an important source of erosion on the Moon? **Look very carefully at Fig. 2.2.**

4. Do all the craters have the same fresh, sharp, new appearance? Describe the various appearances.

5. What do you think has happened in this area?

6. How large is the central crater in the photo? The width of Fig. 2.2 is approximately 150 km (1" = 25 km).

7. Are all craters bowl-shaped? Describe.

8. What everyday events have you observed that are similar to those which form a cratered terrain as in the photo?

*9. From all that you have seen, what does the appearance of a crater tell you about its age? Explain.

PART D: THE EFFECT OF INCIDENCE ANGLE

1. The target (surface) into which a projectile (meteorite) impacts also helps to control the final crater's form. The angle of incidence is also important. You will now investigate both of these variables.

It is important to control all other variables. Be sure to use identical projectiles in each of the four parts. It is suggested that you use a simple device (e.g., a piece of string) to ensure that the slingshot is

ORIGINAL PAGE
BLACK AND WHITE PHOTOGRAPH

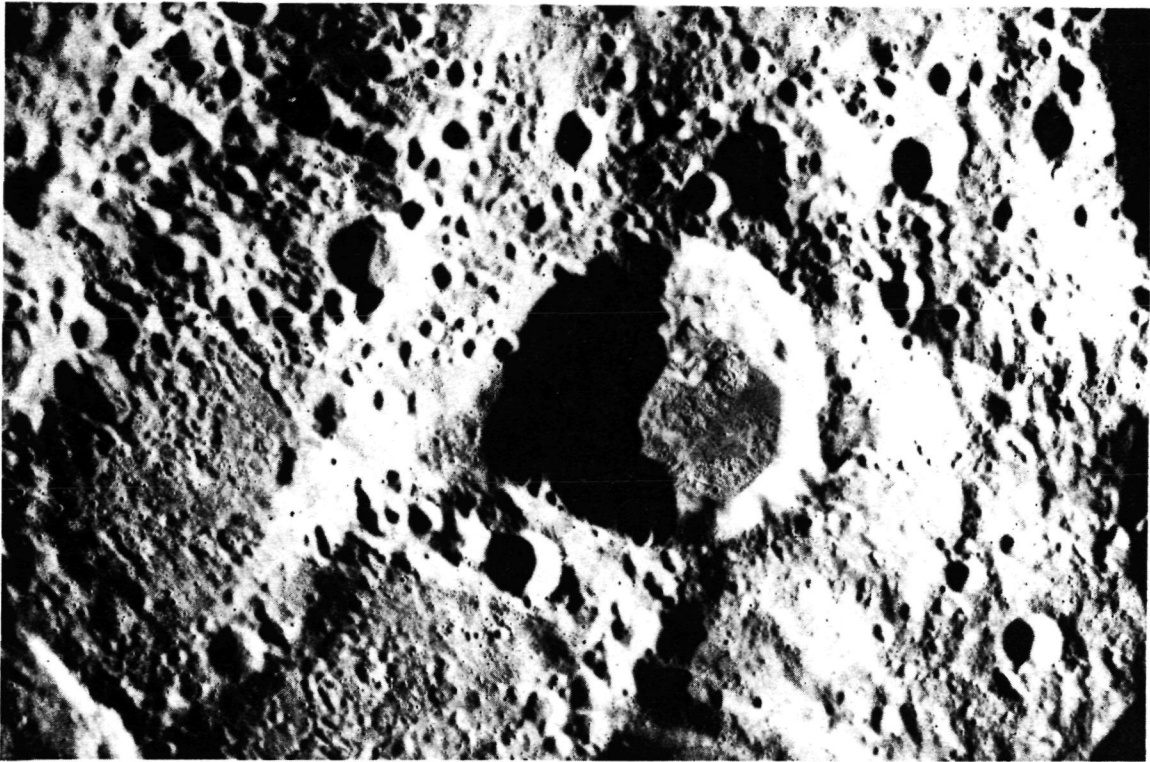

Fig. 2.2: Portion of Apollo 15 metric photograph AS15 1023. Mapping camera photograph of the Moon. The central crater is Levi Civita A. North is to the top.



Fig. 2.3: Portion of Apollo 11 Hasselblad 70 mm photograph AS11-42-6233. Messier (right) and Messier A (left) craters on the Moon. North is to the top.

stretched the same distance each time (controlling the velocity). For best results the projectile must impact at high velocity; therefore, the slingshot should be greatly extended. THIS ACTIVITY IS POTENTIALLY THE MOST HAZARDOUS.

2. Mix the sand in the tray thoroughly, adding more sand if necessary, to return the sand to a uniform color. Remove all projectiles. Smooth the top again with the meter stick. Divide the tray into four equal areas. Again sift a layer of tempa color over the entire tray.
3. In one quarter-section produce a crater using the slingshot to launch a marble fired normal (at 90° , or vertical) to the target surface. On the page provided sketch a plan (map) view and cross section of the crater. Be sure to sketch the pattern of the *ejecta*. Where did it come from?

What would you expect to find beneath the ejecta?

4. In the second quarter-section, produce a crater with a marble launched at about 65° to the surface (estimate the angle). Sketch the crater in the appropriate place. Is there a marked difference between the two craters or ejecta pattern?
5. In the third quarter-section, produce a crater with a marble launched at about 40° to the surface. Be sure no one is "down range" in case the projectile ricochets. Sketch the crater.
6. In the fourth quarter-section, produce a crater with a marble launched at about $5-10^\circ$ to the surface. Be sure no one is "down range" in case the projectile ricochets. Sketch the crater. Note the *asymmetric* cross section.
7. Examine the sand craters and your sketches. What are the relationships between impact angle, crater morphology (shape, form) and ejecta distribution?

8. Examine the Apollo 11 photograph (Fig. 2.3) of the lunar crater Messier (right) and Messier A (left). North is to the top in the photo. Messier is more than 2 km deep, 14 km along its east-west axis, and 8 km wide. What interpretations can you make concerning its formation? Did the projectile enter from the east or west? Comment on the ejecta distribution.

DIAGRAM FOR PART D, STEPS 3 & 4

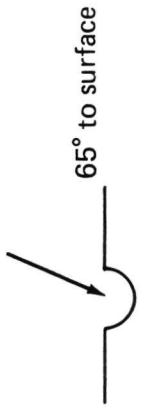
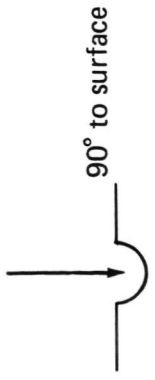

draw plan view above, scale = 0 20 cm

draw plan view above, scale = 0 20 cm

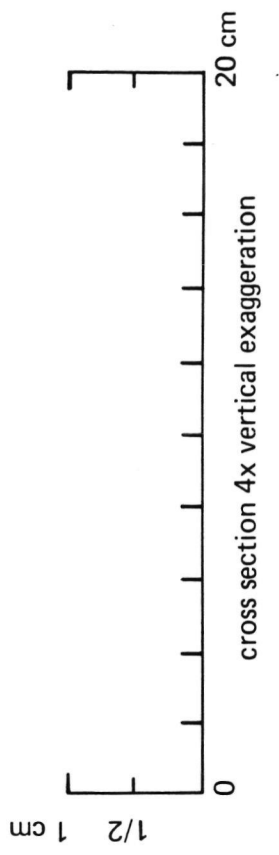
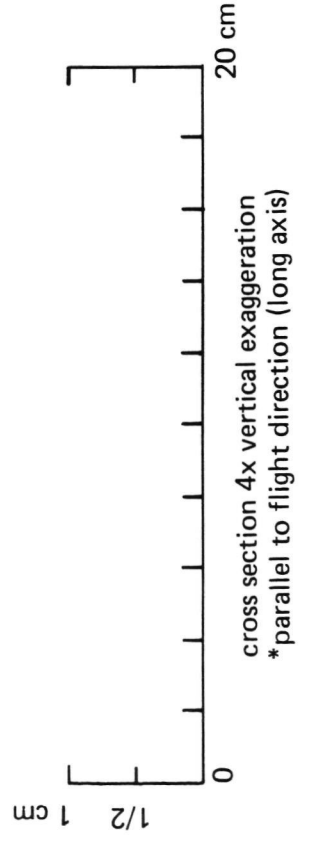

ORIGINAL PAGE IS
OF POOR QUALITY

DIAGRAM FOR PART D, STEPS 5 & 6

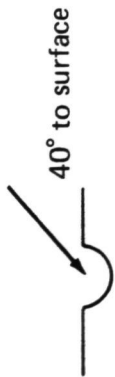

draw plan view above, scale =  20 cm

draw plan view above, scale =  20 cm

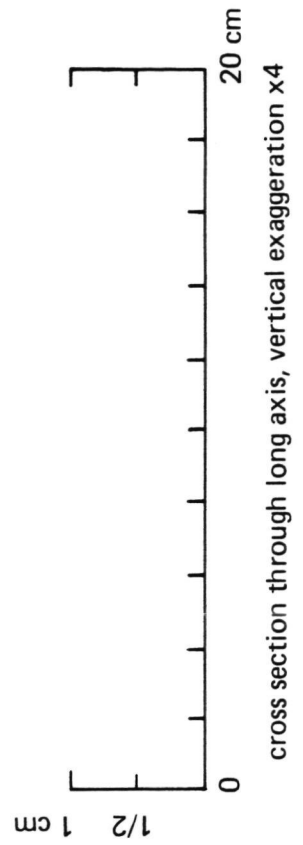
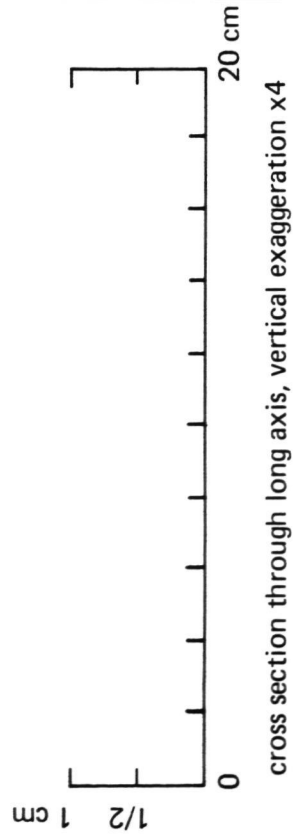

PART E: THE EFFECT OF TARGET STRENGTH

1. Again thoroughly mix the sand in the tray and level the surface. Sprinkle and soak the sand with water; drain off any excess water. With the sieve sprinkle one color of the dry tempera paint evenly over the surface and let it soak completely. Shoot a marble from the slingshot into the wet sand and measure the diameter of the crater. Record observations in the space below.

2. Even out the wet, colored sand by striking or jarring the box several times. Next, sprinkle through the sieve clean, dry, white sand on top of the wet colored sand until a few mm layer of dry sand is formed. With the slingshot, fire a small marble vertically into the sand in one half of the tray. How does the resulting crater compare in diameter to the crater formed in wet sand only?

In dry sand only?

Sketch the profile of your crater and describe the appearance.

3. Pour more sand into one large corner of the tray to increase the dry sand layer to double its thickness. Form another crater with the slingshot in this thicker layer. How does this differ from the crater formed in the thinner layer of sand?

How do these craters compare to the crater formed completely in dry sand?

What effect does the thickness of the dry sand layer have on both the appearance of the crater and crater diameter?

4. Carefully smooth the dry sand to uniform layer over the entire tray. Sprinkle the second color tempera paint evenly through the sieve on top of this layer. Draw a cross section that shows the sequence of layers from top to bottom. Fire a marble with the slingshot into the tray and describe the resulting pattern of material thrown out of the crater (impact ejecta). Where is the ejecta the thickest? Describe the ejecta pattern by color.

Draw a new cross section showing the sequence of layers from top to bottom: near the rim; one crater diameter from the rim; and four crater diameters from the rim.

Which layer goes the farthest?

5. If you were on Mercury and wanted to examine the oldest rocks around a crater, where would you most likely find them?
6. The gravitational acceleration at the surface of a planet also helps to control the final crater's form. How would craters on the Moon differ from those formed on Earth due only to gravity (neglecting all other effects)?

How would gravity modify craters with age?

7. What other environmental factors control the crater's initial form after impact? Describe how these effects would be realized.

IMPACT CRATERING

(Instructor's Key)

PART A: THE FORMATION OF CRATERS

The following experiments deal with the relationships among projectile mass, velocity and crater size. Impacts involve the transfer of energy from the projectile to the target (ground). **Kinetic energy** (energy of motion) is defined as: $K.E. = 1/2 mv^2$, where m = mass and v = final velocity.

PROCEDURE AND QUESTIONS

1. **The Importance of Mass.** Pour sand into the tray to a depth of at least 3 inches. Smooth the surface of the sand with the edge of the meter stick. Divide the surface into two equal areas. Weigh each projectile and record the mass in the table. From a height of 2 meters (6') drop each of the large spheres (three different types) into one area. Carefully measure and record the diameter of the craters formed by the impacts without disturbing the sand. Fill in the table below:

OBJECT	TYPE OF OBJECT	MASS OF OBJECT	CRATER DIAMETER
Sphere #1	<i>Type A</i>	<i>lightest gm</i>	<i>smallest cm</i>
Sphere #2	<i>Type B</i>	<i>medium gm</i>	<i>medium cm</i>
Sphere #3	<i>Type C</i>	<i>heaviest gm</i>	<i>largest cm</i>

The numbers will depend on the material used in the experiment, but the trend should be clear: as mass increases, so does crater diameter.

2. Look at your results carefully. Which sphere created the largest crater?

The most massive.

3. What is the *only* difference in the way each crater was made?

The mass was varied.

4. Each sphere represents a meteorite. What can you say about the importance of the *mass* of a meteorite in making a crater?

Crater diameter increases with increasing mass.

5. Did any sphere appear to fall faster than the others? Did it really? Why or why not?

All spheres reached the sand in the same amount of time, regardless of mass. Galileo was reported to have shown this about 400 years ago.

6. **The Importance of Velocity.** Locate the four identical marbles. Weigh each marble and record its mass below. Drop one marble into the second area from a height of 10 cm and another from 2 meters. The third projectile should be launched from the slingshot extended 23 cm (9"); the fourth, from the slingshot extended 36 cm (14"). Without disturbing the sand, carefully measure the crater diameter.

CAUTION: THE SLINGSHOT IS A POTENTIALLY HAZARDOUS DEVICE. USE EXTREME CAUTION WHEN IT IS EMPLOYED IN THIS ACTIVITY. UNDER NO CIRCUMSTANCES SHOULD IT BE AIMED HORIZONTALLY.

Complete the following table:

	VELOCITY	MASS	CRATER DIAMETER
Marble 1	140 cm/sec	<i>x gm</i>	<i>small cm</i>
Marble 2	626 cm/sec	<i>x gm</i>	<i>medium cm</i>
Marble 3	1000 cm/sec†	<i>x gm</i>	<i>large cm</i>
Marble 4	3000 cm/sec†	<i>x gm</i>	<i>very large cm</i>

† approximate

7. Did you measure any difference in the diameters of the craters?
Yes, as velocity increases, so does crater diameter.
8. What is the *only* difference in the way each crater was made?
Velocity.
9. In this case each marble (meteorite) had the same mass. What did dropping two marbles from different heights and propelling the other two accomplish?
This varies the velocity at impact.
10. Besides diameter do you notice any other difference in appearance among the craters?
No, all look qualitatively similar.
- *11. Which do you think is more important in creating larger craters, more mass or more velocity? Why?
Velocity increases have more effect on crater diameter than mass increases. Velocity has a greater contribution to the energy of impact.

- *12. Calculate the kinetic energy † upon impact for each marble in Question 6.

	<i>KE</i>
Marble 1	$(\frac{1}{2}) \times (\underline{m_1} \text{ gm}) \times (140 \text{ cm/sec})^2 \text{ ergs}$
Marble 2	$(\frac{1}{2}) \times (\underline{m_2} \text{ gm}) \times (626 \text{ cm/sec})^2 \text{ ergs}$
Marble 3	$(\frac{1}{2}) \times (\underline{m_3} \text{ gm}) \times (1000 \text{ cm/sec})^2 \text{ ergs}$
Marble 4	$(\frac{1}{2}) \times (\underline{m_4} \text{ gm}) \times (3000 \text{ cm/sec})^2 \text{ ergs}$

- *13. Examine the results in Part A. Summarize your conclusions regarding the size, mass, and velocity of impacting projectiles, and its *kinetic energy* (indicated by the size of the resulting crater).

The greater the energy released on impact, the larger the crater. Mass and velocity contribute to energy, not size. Velocity contributes as the square, mass linearly.

PART B: THE STRUCTURE OF A CRATER

1. Remove all projectiles from the sand and smooth the surface well. Again divide the tray into two areas. With your instructor's help sprinkle a very fine layer of dry tempera color over the sand using the tea strainer. The layer of colored powder should cover the surface just enough to conceal the white sand.

CAUTION: WEAR THE GOGGLES AND BE SURE THAT NO GLASS OR BREAKABLE MATERIALS ARE IN THE VICINITY OF THE ACTIVITY.

2. Use the slingshot to shoot the 1/2" steel sphere vertically into the sand. DO NOT DISTURB THE CRATER IN THE FOLLOWING STEPS.
3. Draw two pictures, one in each box on the next page, of the crater, one looking down from above (map view) and one as seen from *ground level* (elevation or side view).

† If mass is measured in grams and velocity in cm/sec, then kinetic energy is given in ergs, or gm X cm²/sec². For comparison the energy equivalent of one calorie of heat is 4.2 X 10⁷ ergs.

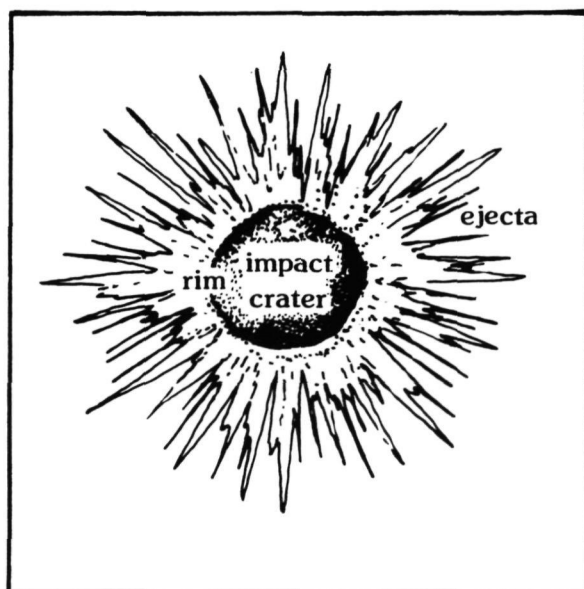

Map View

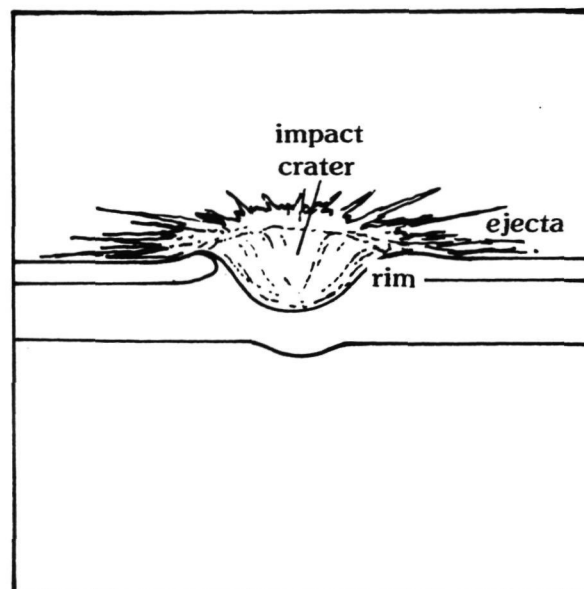

Side View

This is an ideal example of a small fresh crater.

4. Label the drawings with the words rim, ejecta and impact crater. Notice the sharp details of the crater.

5. Where do you find the thickest ejecta?

On the rim.

6. What do you think caused the crater rim to form?

Deposition of sand thrown out of cavity formed by impact.

- *7. The colored powder represents the most recent sediment deposited on a planet's surface. Any material beneath the top layer must have been deposited at an earlier time (making it physically older). If you were examining a crater on the Moon, where would you probably find the oldest material? Why do you think so?

Near the rim. Because the deepest material ejected lands closest to the crater, i.e., on the rim.

PART C: CRATERING AS GEOLOGIC PROCESS

1. In the second area create another crater as in Part B. Locate the large pack of assorted marbles. Drop each marble in the pack from an arbitrary height into the second area so that each one impacts at a different speed. Be careful to drop the marbles **near but not directly on top of** the crater formed by the slingshot method. Watch the process very carefully as you do it.

2. How does the appearance of the original crater from Part B change as you continue to bombard the area?

It loses its crispness.

3. What do you think is an important source of erosion on the Moon? **Look very carefully at Fig. 2.2.**

Impact cratering.

4. Do all the craters have the same fresh, sharp, new appearance? Describe the various appearances.

No—smooth rims to sharp rims, bowl-shaped to elliptical, etc.

5. What do you think has happened in this area?

Long term bombardment.

6. How large is the central crater in the photo? The width of Fig. 2.2 is approximately 150 km (1" = 25 km).

About 40 km.

7. Are all craters bowl-shaped? Describe.

No—there is a variety of shapes.

8. What everyday events have you observed that are similar to those which form a cratered terrain as in the photo?

Raindrops on dirt or sand, etc.

- *9. From all that you have seen, what does the appearance of a crater tell you about its age? Explain.

The younger the crater, the crisper the features; the older, the more subdued.

PART D: THE EFFECT OF INCIDENCE ANGLE

1. The target (surface) into which a projectile (meteorite) impacts also helps to control the final crater's form. The angle of incidence is also important. You will now investigate both of these variables.

It is important to control all other variables. Be sure to use identical projectiles in each of the four parts. It is suggested that you use a simple device (e.g., a piece of string) to ensure that the slingshot is

stretched the same distance each time (controlling the velocity). For best results the projectile must impact at high velocity; therefore, the slingshot should be greatly extended. THIS ACTIVITY IS POTENTIALLY THE MOST HAZARDOUS.

2. Mix the sand in the tray thoroughly, adding more sand if necessary, to return the sand to a uniform color. Remove all projectiles. Smooth the top again with the meter stick. Divide the tray into four equal areas. Again sift a layer of tempera color over the entire tray.
3. In one quarter-section produce a crater using the slingshot to launch a marble fired normal (at 90° , or vertical) to the target surface. On the page provided sketch a plan (map) view and cross section of the crater. Be sure to sketch the pattern of the *ejecta*. Where did it come from?

Ejecta comes from sand below the tempera layer that was excavated by impact.

What would you expect to find beneath the ejecta?

Undisturbed sand.

4. In the second quarter-section, produce a crater with a marble launched at about 65° to the surface (estimate the angle). Sketch the crater in the appropriate place. Is there a marked difference between the two craters or ejecta pattern?

The craters and ejecta pattern should appear similar.

5. In the third quarter-section, produce a crater with a marble launched at about 40° to the surface. Be sure no one is "down range" in case the projectile ricochets. Sketch the crater.
6. In the fourth quarter-section, produce a crater with a marble launched at about $5-10^\circ$ to the surface. Be sure no one is "down range" in case the projectile ricochets. Sketch the crater. Note the *asymmetric* cross section.
7. Examine the sand craters and your sketches. What are the relationships between impact angle, crater morphology (shape, form) and ejecta distribution?

High impact angles produce more nearly bowl-shaped craters with symmetric ejecta patterns; shallow impact angles produced elongated or elliptical craters and asymmetric or "butterfly wing" ejecta.

8. Examine the Apollo 11 photograph (Fig. 2.3) of the lunar crater Messier (right) and Messier A (left). North is to the top in the photo. Messier is more than 2 km deep, 14 km along its east-west axis, and 8 km wide. What interpretations can you make concerning its formation? Did the projectile enter from the east or west? Comment on the ejecta distribution.

It is likely that Messier was created by a shallow angle impact. The projectile entered from the right side of the picture (from the east). Most ejecta was distributed forward or down range and as north and south "wings".

PART E: THE EFFECT OF TARGET STRENGTH

1. Again thoroughly mix the sand in the tray and level the surface. Sprinkle and soak the sand with water; drain off any excess water. With the sieve sprinkle one color of the dry tempera paint evenly over the surface and let it soak completely. Shoot a marble from the slingshot into the wet sand and measure the diameter of the crater. Record observations in the space below.

Small, marble-sized crater with clumpy ejecta.

2. Even out the wet, colored sand by striking or jarring the box several times. Next, sprinkle through the sieve clean, dry, white sand on top of the wet colored sand until a few mm layer of dry sand is formed. With the slingshot, fire a small marble vertically into the sand in one half of the tray. How does the resulting crater compare in diameter to the crater formed in wet sand only?

Larger crater than in wet sand.

In dry sand only?

Smaller than in dry sand.

Sketch the profile of your crater and describe the appearance.



Answers will vary, but floor should appear flat.

3. Pour more sand into one large corner of the tray to increase the dry sand layer to double its thickness. Form another crater with the slingshot in this thicker layer. How does this differ from the crater formed in the thinner layer of sand?

Larger crater, smaller floor.

How do these craters compare to the crater formed completely in dry sand?

Smaller overall, but flatter floor.

What effect does the thickness of the dry sand layer have on both the appearance of the crater and crater diameter?

The thicker the overlying dry layer, the closer the crater approaches the dry sand craters.

4. Carefully smooth the dry sand to uniform layer over the entire tray. Sprinkle the second color tempera paint evenly through the sieve on top of this layer. Draw a cross section that shows the sequence of layers from top to bottom. Fire a marble with the slingshot into the tray and describe the resulting pattern of material thrown out of the crater (impact ejecta). Where is the ejecta the thickest? Describe the ejecta pattern by color.

The deepest color is closest to the rim; the shallowest color is farthest from the rim. Ejecta is thickest near the rim.

Draw a new cross section showing the sequence of layers from top to bottom: near the rim; one crater diameter from the rim; and four crater diameters from the rim.

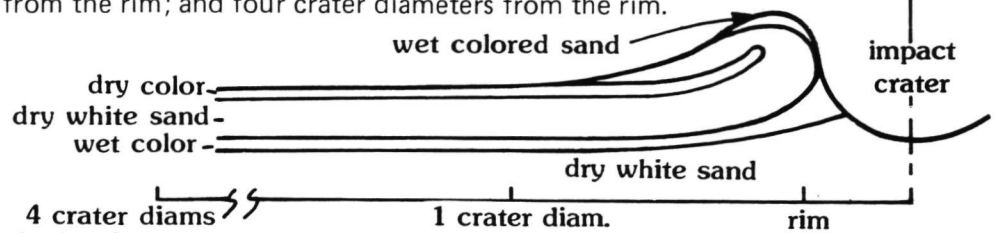

Which layer goes the farthest?

The topmost layer.

5. If you were on Mercury and wanted to examine the oldest rocks around a crater, where would you most likely find them?

Near the rim.

6. The gravitational acceleration at the surface of a planet also helps to control the final crater's form. How would craters on the Moon differ from those formed on Earth due only to gravity (neglecting all other effects)?

Lower profiles, larger surface area of ejecta.

How would gravity modify craters with age?

Higher gravity decreases degradation by multiple impacts, but increases degradation by slumping.

7. What other environmental factors control the crater's initial form after impact? Describe how these effects would be realized.

Atmospheric effects, entrapped fluids or volatiles in the target, etc.

COMPARING CRATERING PROCESSES

OBJECTIVES

1. By using lab materials, the formation of craters through impact, eruptive, and explosive processes will be simulated.
2. The effects of different cratering processes on landscape development will be compared.
3. Through the use of photographs and direct observation, the origins of specific craters can be determined.

MATERIALS

- | | |
|---|--|
| <ol style="list-style-type: none"> 1. Tray of very fine sand (100 μm) 2. Protective goggles 3. Marbles and slingshot 4. Polaroid camera with cable release 5. 3 packs of Polaroid black and white film 6. Black cardboard or posterboard (18"x30") 7. High intensity strobe light variable to at least 15 flashes per second 8. 3 foot plastic tube 9. Bicycle pump | <ol style="list-style-type: none"> 10. Thin skin balloons 11. Protractor 12. Tracing paper 13. Curtain/plastic sheet |
|---|--|

PROCEDURE AND QUESTIONS

PART A: IMPACT CRATER PROCESS

1. Focus the camera on the tray of sand from a distance of 2 to 3 feet. To get good photos, the film must be exposed long enough to catch 2 flashes from the strobe light (about 1/8 second). Start the exposure just before the marble is fired and stop it right after it appears to hit the sand.

CAUTION: ALL STUDENTS MUST WEAR THE SAFETY GOGGLES DURING THIS PORTION OF THE EXERCISE. THIS IS ESPECIALLY IMPORTANT HERE BECAUSE THE FLASHING STROBE LIGHT OFTEN CAUSES ERROR IN AIM.

Step 1 may have to be repeated several times to get a good photograph. Save all photographs.

2. a. Before looking at the photograph, describe how you think the sand thrown from the impact (called "ejecta") will look.

.....

.....

- b. Sketch the crater and the path the material appears to take based on the photograph and observations.

c. How does the crater formed differ from the predictions?

.....
.....

d. Take at least three more photographs. Arrange them in a time sequence beginning with an exposure the instant before impact and ending with one after the impact. How does the ejecta pattern change.

.....
.....
.....

3. IMPACTS AT AN ANGLE: Repair and smooth the sand surface and photograph another impact with the angle of impact at 45° from the horizontal. Be sure that no one is down range and that you fire in the direction of the hanging curtain. How are the ejecta paths different from the vertical impact?

.....
.....
.....
.....

PART B: EXPLOSIVE CRATER PROCESS

1. Attach the plastic tube to the bicycle pump. Check for air leaks. Next, pull the balloon tightly over the other end of the tube and slip on the clamp. This means that you are using only a small portion of the balloon and that the thin skin of the balloon will burst easily when the pump is used.
2. Bury the tube in the sand but turn up the end in the center of the box so that it is almost vertical and about $3/4''$ below the surface of the sand.
3. As in the impact experiment, start the Polaroid picture exposure immediately BEFORE the quick single push of the bicycle pump and stop the exposure immediately afterwards (1/8 second). If the balloon did not burst, check for air leaks or tighten the clamp on the balloon.
4. a. Before looking at the photo, again predict what you think you will see.

.....
.....
.....

b. How does your prediction compare with the photo? Sketch the crater and ejecta pattern.

c. How does the resulting crater (which is a "low-energy" explosion crater) compare with the impact crater?

.....
.....
.....
.....

d. Compare the photos with those from other groups who have done the experiment.

.....
.....

PART C: ERUPTIVE CRATER PROCESS

1. After completing the previous experiment, leave the tube buried in the sand. Smooth the surface of the sand over the end of the tube.

2. For the final photograph, start the exposure immediately BEFORE pushing the pump (do not push as hard as for the balloon). Now what do you predict for the pattern of ejecta?

.....
.....

3. Sketch the pattern that you observed.

4. What geologic process might produce a similar pattern?

.....
.....

5. Place the photographs you have taken side by side. Compare the craters and features formed by each of the three processes.

a. How are all three similar?

.....
.....

b. How are they different?

.....
.....

c. Which have raised rims?

.....
.....

d. Which crater formed the widest ejecta pattern?

.....
.....

e. How do the ejecta patterns compare to one another?

.....
.....

f. Which process had the biggest effect on the surrounding material?

.....

6. Examine Fig. 2.4 and Fig. 2.5.

a. Which feature is probably volcanic?

Which feature is probably impact?

b. What evidence did you use to reach your conclusion?

.....

c. If you were looking for a crater produced by an explosion, what special features would you look for that would distinguish it from craters formed by volcanic eruptions and impacts?

.....
.....

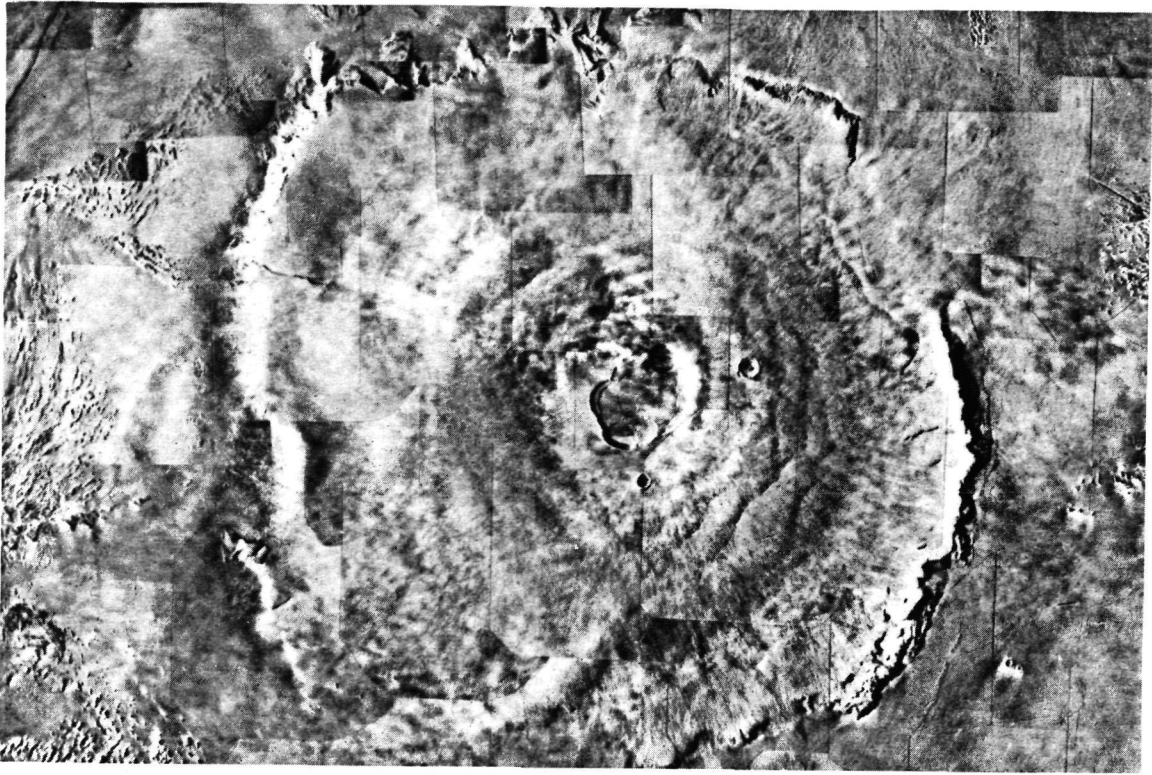

Fig. 2.4: Viking Orbiter mosaic number 211-5360. North is to the top. Feature name: Olympus Mons. Planet: Mars.

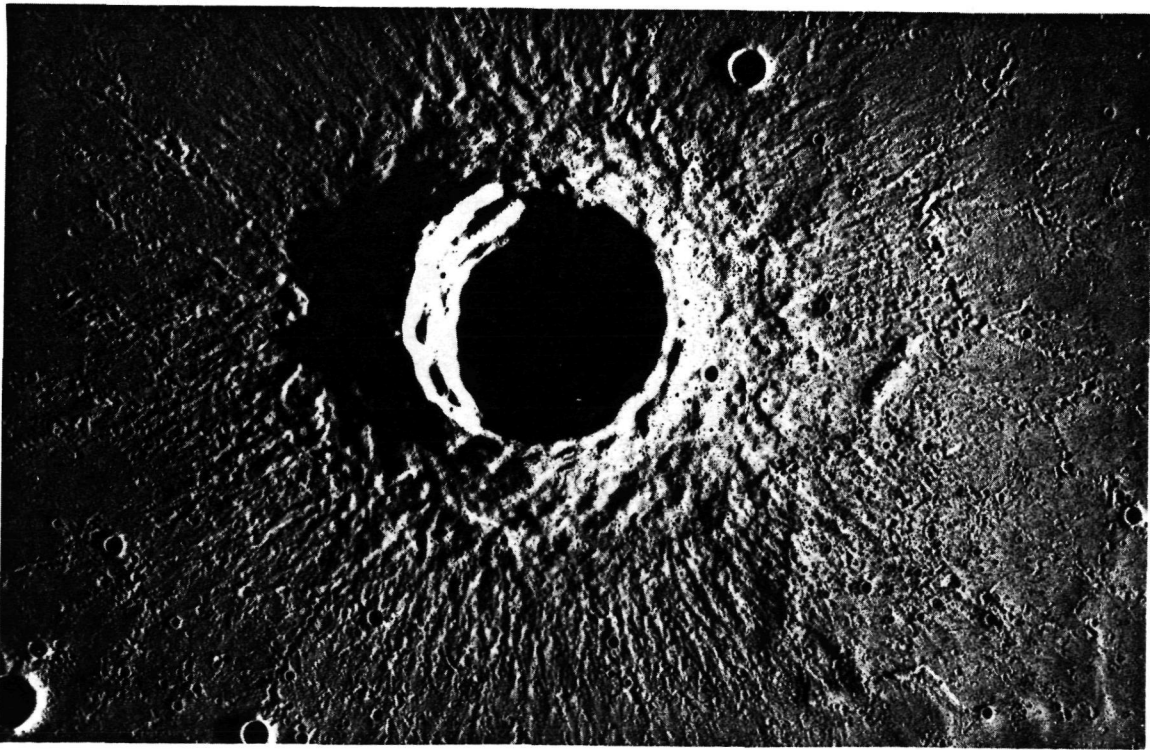

Fig. 2.5: Apollo 15 metric photograph AS15 0598. Mapping camera photo, rev 22, north to the top. Feature name: Timocharis. Planet: Earth's Moon.

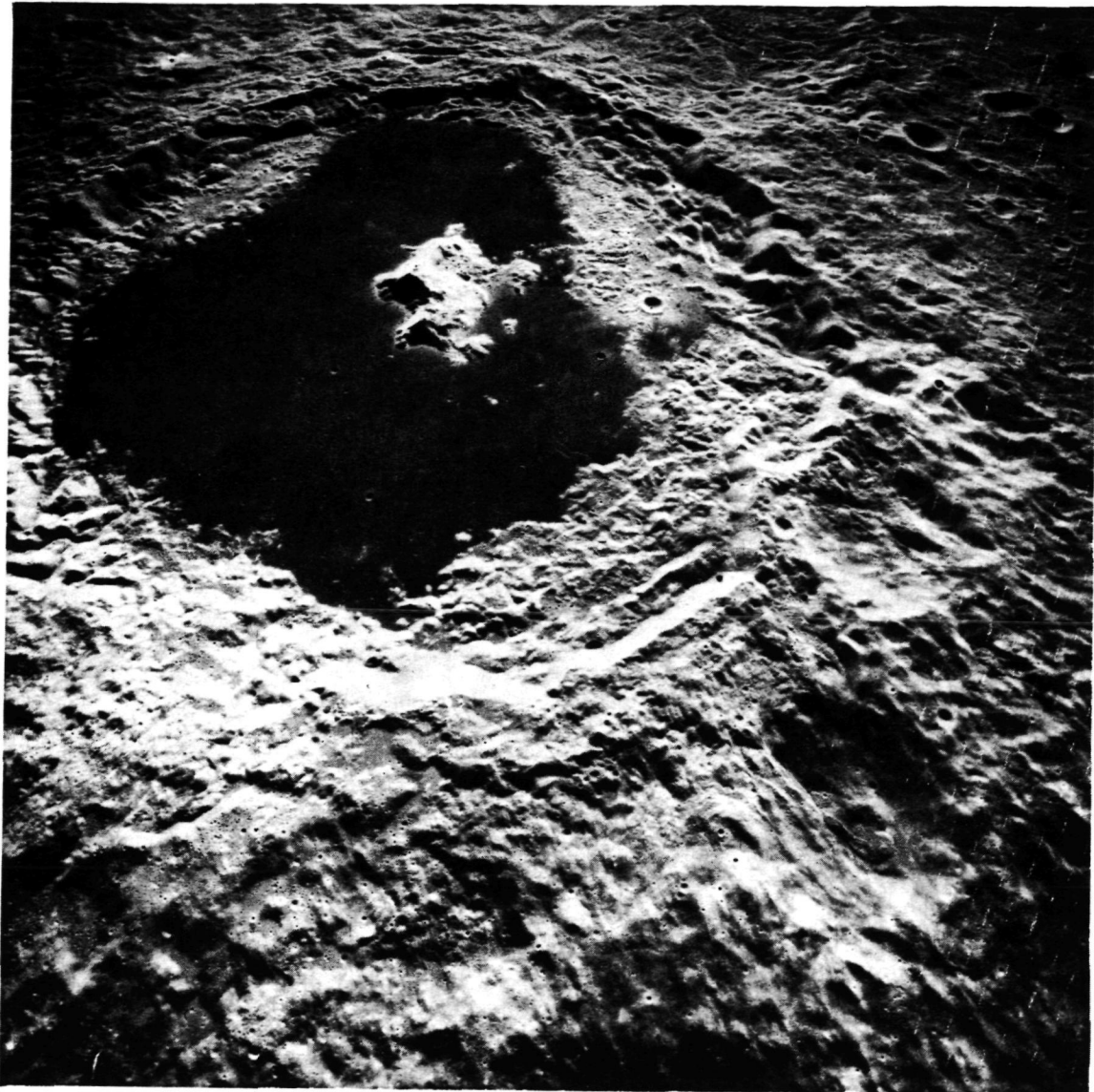

Fig. 2.6: Apollo 15 metric photograph AS15 0758. Mapping camera photo, rev 33, oblique view, north to the right. Feature name: Tsiolkovsky Crater. Planet: Earth's Moon.

*7. Examine Fig. 2.6.

a. List the processes you think are responsible for Tsiolkovsky as we now see it.

.....

b. What evidence did you use to reach your conclusions?

.....

c. What could have caused the mountain peaks in the center of Tsiolkovsky?

.....

COMPARING CRATERING PROCESSES

(Instructor's Notes)

PRE-LAB

15 minutes. Go over techniques of using the Polaroid camera

LAB

Two class periods

POST-LAB

1. Discuss results of photos or observations.
2. View the film "Controversy Over the Moon."

NOTES FOR SET-UP FOR LAB

1. Because of the sand thrown out by impact and the use of the slingshot, goggles are necessary for each student. The slingshot is important because a high velocity projectile is needed to produce a good ejecta blanket.
2. Prepare the lab set-up before class in order to avoid loss of time in beginning the exercise.
3. A Polaroid camera was selected for this exercise to allow students an opportunity to have an instant and permanent record of the exercise. Action is stopped by use of the strobe and students can reshoot if necessary. If desired, a 35 mm camera or Instamatic with a 2' focus can be used; however, this will delay examination of photographs and errors in procedure will not be detected until the film results are viewed. The school newspaper or yearbook photographers may be able to assist you in developing the film.
4. Instructions for setting up the lab:
 - a. Fill the tray to the brim with 100 μm sand and arrange the strobe and camera as shown on page 47.
 - b. If the Polaroid has an electric eye, set the film speed setting to 75 (even though the film speed is 3000) and the exposure control on front of the camera to "Darker." This permits a longer exposure time for the shutter and a smaller f/stop (lens opening). If the Polaroid does not have an electric eye, but has numbered settings, set the number to "6" and flip the exposure from "I" to "B" before each picture. If the resulting photographs are too light, increase this number accordingly.
 - c. Focus the camera on the target surface and place the black posterboard in front of and beneath the strobe light as shown. This arrangement provides a black background. The flash rate on the strobe should seem like rapid blinks. Too many flashes during the exposure produces a dispersed cloud; too few, and the event may be missed entirely.
 - d. In using the camera, it is best if you have a cable release attached to the Polaroid — this will help eliminate jarring the camera unnecessarily. If the camera does not accept a cable release, be sure that the camera is on a firm surface; push the button and release carefully.
5. Be sure the student photographers know how to operate a Polaroid before starting the activity.

NOTE: ALTHOUGH THE INSTRUCTIONS AND PRECAUTIONS MAY SEEM INVOLVED, THE EXERCISE CAN BE DONE EASILY AND SUCCESSFULLY.

ORIGINAL PAGE IS
OF POOR QUALITY

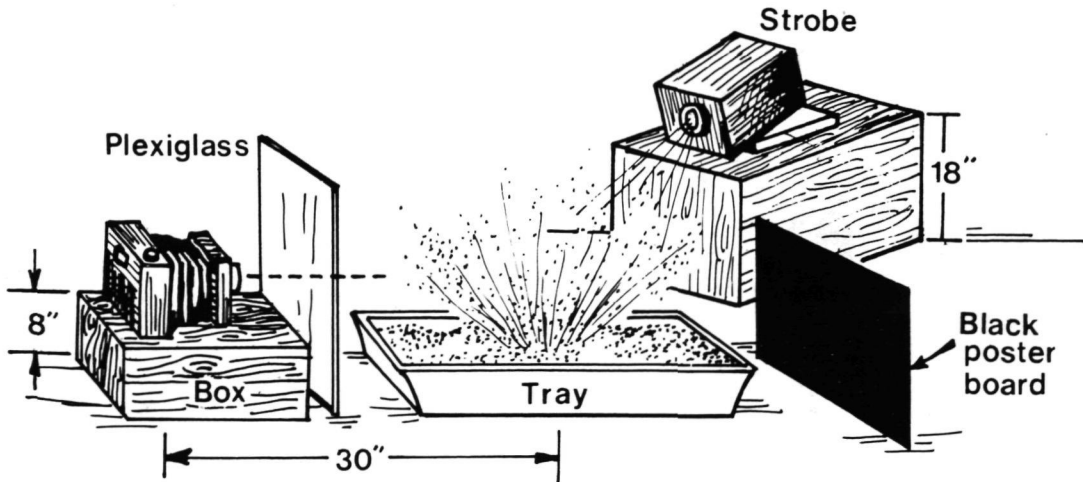

Diagram showing set-up for photographing cratering experiments.

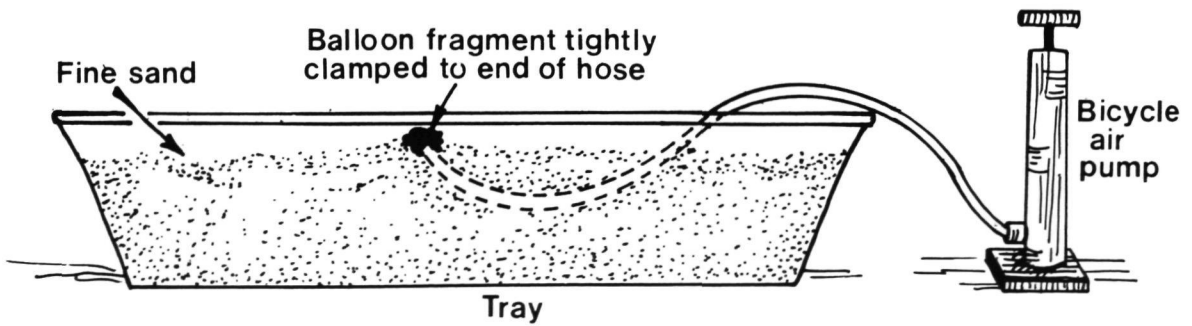
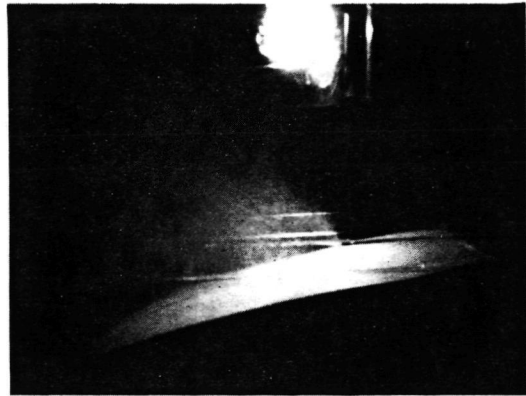
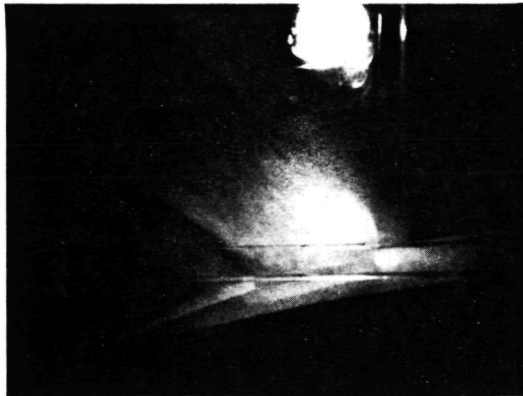
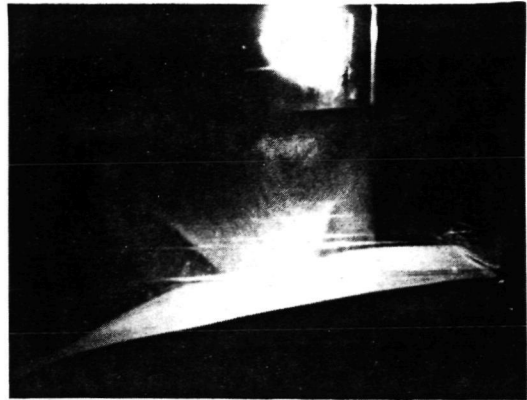

Diagram showing set-up for "explosive" cratering experiments.

ORIGINAL PAGE
BLACK AND WHITE PHOTOGRAPH



Strobe-light Polaroid photographs of impacts into fine sand at different angles of incidence. Photograph records two flashes of the strobe light in each illustration. The innermost cone represents material (ejecta) thrown from the crater as the crater forms. The ejecta leave the surface primarily at a 45° angle for a vertical impact (upper left, as looking from right side). The ghost-like second image indicates a later stage in crater formation and illustrates the sheet of ejecta that moves outward. As the angle of impact departs from the vertical, the ejecta cone or plume becomes asymmetric. For the relatively low velocities represented here (20 m/s), asymmetry is not apparent until the impact angle (angle from the vertical) is greater than 20° . At 20° (upper right), the sequence of ejecta remains relatively symmetric. At 60° (lower left) and 75° (lower right) from the vertical, the ejecta cone is distorted in the downrange direction. For impacts of much greater velocities (2 km/s), the asymmetry does not occur until much larger departures (80°) from the vertical.

Note in the impacts in the upper right and lower left that the ejecta paths remain in a sheet that forms an inverted cone. The sheet moves outward from the point of impact, and the base of the cone sheet enlarges. This arrangement indicates that the ejecta strike the surface in a narrow annulus that increases in diameter (not necessarily width) with time.

ORIGINAL PAGE IS
OF POOR QUALITY

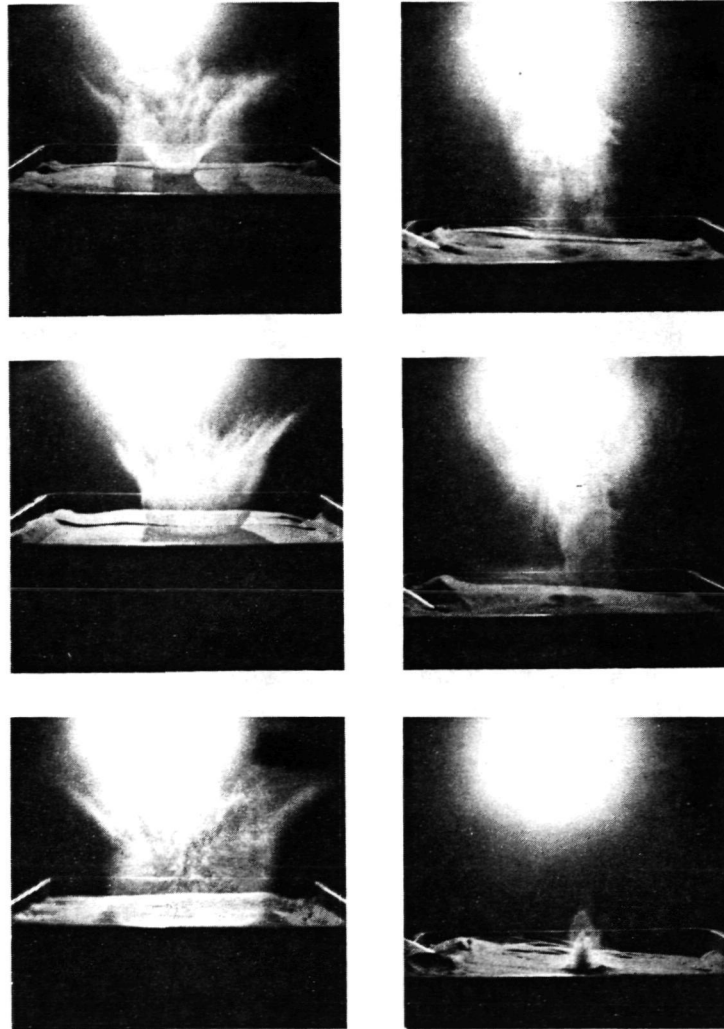

Comparison of the formation of impact craters (left side), low-energy explosion craters (top two photos on right side), and simulated volcanic craters (bottom right), as recorded in a sand box with strobe light. The formation of an impact crater is a relatively well ordered event in which the ejecta leave the surface at approximately a 45° angle from the horizontal (upper left). As the crater enlarges (middle left), the inverted cone sheet of ejecta, called the *ejecta plume*, enlarges. Ejecta arrive first in an annulus close to the crater. As crater formation continues (bottom left), the ejecta strike the surface at increasing distances. Note that in all three photographs, two stages in crater formation have been recorded: the earliest stage is represented by the inner ejecta plume (revealed most clearly in the upper left); the second stage, by the broad-based ejecta plume.

In contrast to the impact process, an exploding balloon buried beneath the sand produces a relatively chaotic and dispersed ejecta pattern (upper and middle right). Ejecta blown through a tube are directed vertically and return to the surface near the crater. The former example is analogous to an explosion crater, whereas the latter approximates a volcanic eruption. All three groups of experiments produce craters with raised rims but the mechanics of formation varies significantly. This realization is important for understanding the appearance of craters on other planets and the effect of their formation on the surrounding terrain.

COMPARING CRATERING PROCESSES

(Instructor's Key)

PROCEDURE AND QUESTIONS

PART A: IMPACT CRATER PROCESS

1. Focus the camera on the tray of sand from a distance of 2 to 3 feet. To get good photos, the film must be exposed long enough to catch 2 flashes from the strobe light (about 1/8 second). Start the exposure just before the marble is fired and stop it right after it appears to hit the sand.

CAUTION: ALL STUDENTS MUST WEAR THE SAFETY GOGGLES DURING THIS PORTION OF THE EXERCISE. THIS IS ESPECIALLY IMPORTANT HERE BECAUSE THE FLASHING STROBE LIGHT OFTEN CAUSES ERROR IN AIM.

Step 1 may have to be repeated several times to get a good photograph. Save all photographs.

2. a. Before looking at the photograph, describe how you think the sand thrown from the impact (called "ejecta") will look.

Experience in Unit Two should yield similar answers.

- b. Sketch the crater and the path the material appears to take based on the photograph and observations.

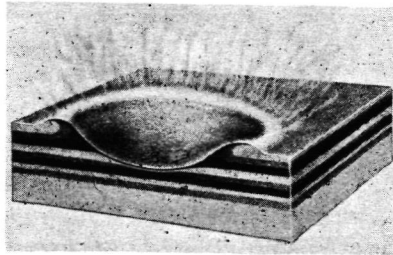

- c. How does the crater formed differ from the predictions?

Instructor should lead a discussion of various student answers.

- d. Take at least three more photographs. Arrange them in a time sequence beginning with an exposure the instant before impact and ending with one after the impact. How does the ejecta pattern change.

Ejecta is laid down by a moving "curtain" of debris from the rim of the crater outward.

3. IMPACTS AT AN ANGLE: Repair and smooth the sand surface and photograph another impact with the angle of impact at 45° from the horizontal. Be sure that no one is down range and that you fire in the direction of the hanging curtain. How are the ejecta paths different from the vertical impact?

Ejecta from the vertical impact are thrown out at about a 45° angle. The sheet of ejecta moves outward in a symmetrical pattern, producing the appearance of an enlarging, inverted cone. As the path of the projectile departs from the vertical, the ejecta cone becomes asymmetrical and distorted in the down-range direction.

PART B: EXPLOSIVE CRATER PROCESS

1. Attach the plastic tube to the bicycle pump. Check for air leaks. Next, pull the balloon tightly over the other end of the tube and slip on the clamp. This means that you are using only a small portion of the balloon and that the thin skin of the balloon will burst easily when the pump is used.
2. Bury the tube in the sand but turn up the end in the center of the box so that it is almost vertical and about $3/4''$ below the surface of the sand.
3. As in the impact experiment, start the Polaroid picture exposure immediately BEFORE the quick single push of the bicycle pump and stop the exposure immediately afterwards (1/8 second). If the balloon did not burst, check for air leaks or tighten the clamp on the balloon.

4. a. Before looking at the photo, again predict what you think you will see.

Instructor should lead a discussion of various student answers.

- b. How does your prediction compare with the photo? Sketch the crater and ejecta pattern.

See photos and discussion on Page 49.

- c. How does the resulting crater (which is a "low-energy" explosion crater) compare with the impact crater?

In appearance, the crater shape is similar. However, the ejecta pattern is chaotic and dispersed with ejecta thrown out at all angles. The impact ejecta pattern is well-ordered with ejecta leaving at a 45° angle. (see Page 49). Note that the ejecta pattern and crater appearance will vary with different depths of burial of the balloon, In high energy explosions, an impact crater can be reproduced if the depth of the explosion is shallow.

- d. Compare the photos with those from other groups who have done the experiment.

Answers will vary.

PART C: ERUPTIVE CRATER PROCESS

The ejecta thrown out in this process is directed nearly vertical and returns to the surface near the crater (see Page 49). In this exercise, students have produced three craters with raised rims. The processes of formation as shown by the stop-action photos are very different.

1. After completing the previous experiment, leave the tube buried in the sand. Smooth the surface of the sand over the end of the tube.
2. For the final photograph, start the exposure immediately BEFORE pushing the pump (do not push as hard as for the balloon). Now what do you predict for the pattern of ejecta?

Answers will vary.

3. Sketch the pattern that you observed.

See photos and discussion on Page 49.

4. What geologic process might produce a similar pattern?

Volcanic eruptions could produce such a crater.

5. Place the photographs you have taken side by side. Compare the craters and features formed by each of the three processes.

- a. How are all three similar?

All three craters contain similar parts: crater, rim and ejecta.

- b. How are they different?

Answers will vary but many students will note that the explosive and volcanic craters are not as symmetrical as the impact craters.

- c. Which have raised rims?

All craters formed have raised rims.

- d. Which crater formed the widest ejecta pattern?

Answers may vary. The explosive crater or the impact crater ejecta patterns will probably be widest.

- e. How do the ejecta patterns compare to one another?

Answers may vary.

- f. Which process had the biggest effect on the surrounding material?

Impact has the greatest effect.

6. Examine Fig. 2.4 and Fig. 2.5.

- a. Which feature is probably volcanic? *Olympus Mons*

Which feature is probably impact? *Timocharis*

- b. What evidence did you use to reach your conclusion?

Timocharis has well developed ejecta patterns; Olympus Mons has what seem to be flow patterns down its flanks.

- c. If you were looking for a crater produced by an explosion, what special features would you look for that would distinguish it from craters formed by volcanic eruptions and impacts?

Impact craters have large, well-defined ejecta patterns; the ejecta patterns of explosion craters may not be as well-organized: volcanic craters have very little ejecta pattern.

- *7. Examine Fig. 2.6.

- a. List the processes you think are responsible for Tsiolkovsky as we now see it.

Impact to form crater and ejecta patterns to bottom, wall failure, and volcanic eruption from beneath to fill the floor.

- b. What evidence did you use to reach your conclusions?

Ejecta patterns radiating from impact site; dark mare fill on floor that is lightly cratered (younger).

- c. What could have caused the mountain peaks in the center of Tsiolkovsky?

Students may suggest volcanoes; this is unlikely. They are central peaks formed by rebound of floor materials after impact.

Name _____

Class _____ Date _____

IMPACT CRATERING ON A RAINY DAY

OBJECTIVE

To illustrate the way in which planetary surfaces can be dated by analyses of craters, you will create impact features with raindrops and will study the craters formed in order to find out the effect of both continuous impacting of a surface and the angle of illumination on the appearance of the cratered terrain.

MATERIALS

1. Rainy day (or something to duplicate raindrops, such as water sprinkled through a fine-mesh window screen)
2. 4 *petri* dishes (per group)
3. Very fine sand (100 μ m)
4. Light source (spot type)
5. Optional: Polaroid camera and film

PROCEDURE AND QUESTIONS

1. Fill each *petri* dish with the fine sand. Place one dish in the light rain for about 5 seconds (or until several craters have formed). How do the crater sizes vary?

.....
.....

Are the craters clustered together? Do they overlap?

.....
.....

2. Form a crater in the second dish with your finger. Place this dish in the rain for approximately 30 seconds.

a. What does the surface look like now?

.....
.....

b. What happened to the large crater you formed?

.....
.....

c. What do you suppose would happen to the larger crater if you left it in the rain for 5 minutes (10 times as long)?

.....
.....

d. Are there more overlapping craters here than in No. 1?

.....

e. Do any of the craters form chains of three or more (three or more in a row)?

.....

3. Form another "finger" crater in each of the other two dishes. Place one dish in the rain for two minutes; the other for four minutes.

a. What has happened to the large craters? Does this agree with your prediction in No. 2?

.....

.....

b. Do you see more tiny craters in either of the dishes? Which dish has the most tiny craters?

.....

.....

4. The angle of the light affects what you see. During a full Moon, you can see less detail on the Moon's surface than you can during the other phases. Turn off the overhead lights and, with the spot light, shine the light across the surface of the dishes. Try shining the light from the following angles and describe what you see.

a. 90° (directly above the craters):

.....

.....

b. 45° ($\frac{1}{2}$ of a right angle):

.....

.....

c. 20° :

.....

.....

d. 10° :

.....

.....

*5. Examine Fig. 2.7.

a. List the evidence you see on the Moon for long term impacting.

b. List the features you see on the Moon that are similar to those produced in the experiment.

c. Describe the effects of changing lighting angle in the photo.

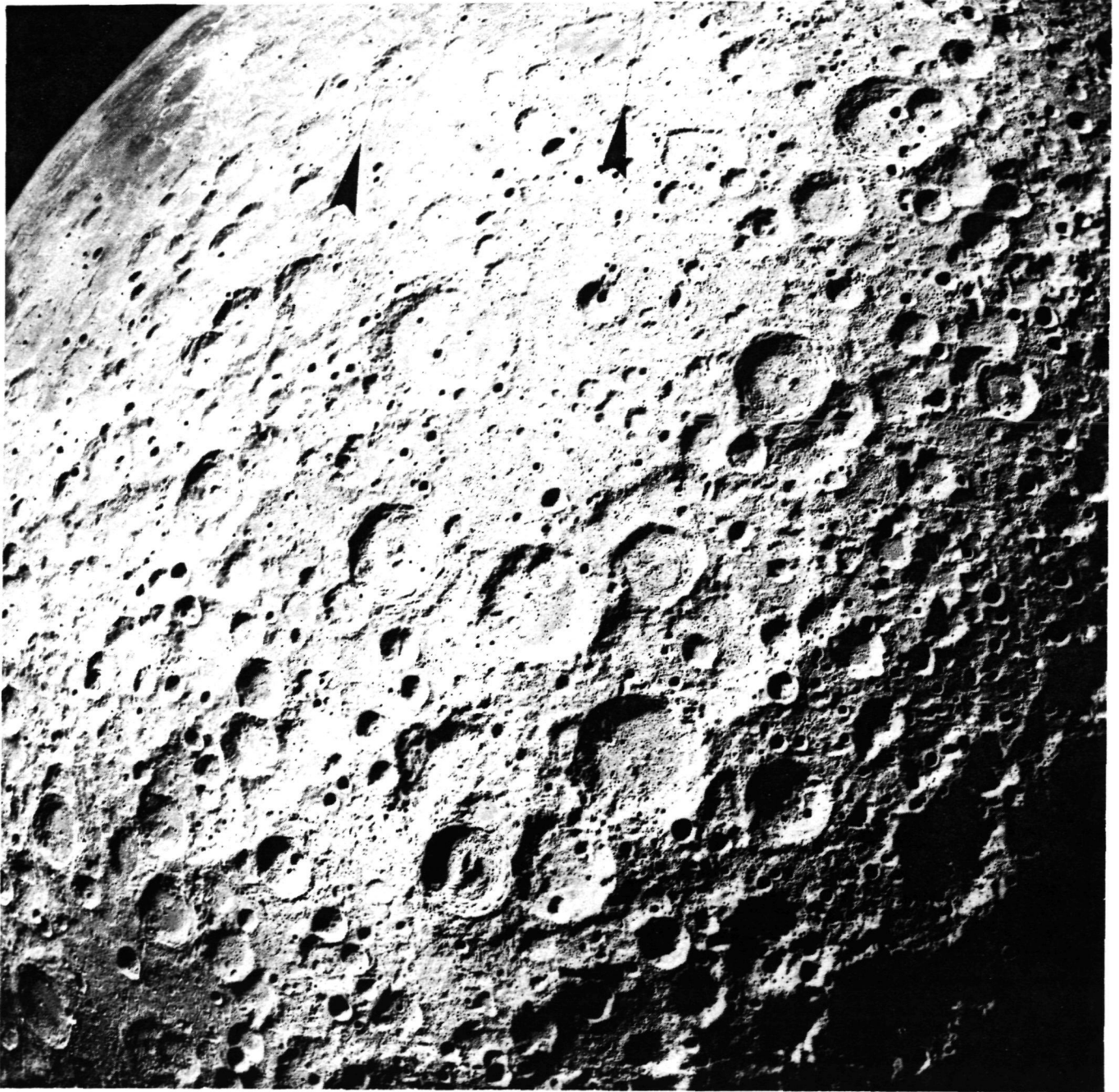

Fig. 2.7: Apollo metric photograph AS16 3003. The ancient lunar highlands is the best example of a heavily cratered surface in "equilibrium". Chains of craters (catena) marked by the arrows, overlapping craters, fresh craters, and degraded craters are all represented. A relatively young mare surface is visible on the limb (lunar horizon). The effect of lighting angle is also easy to see. Craters near the darkness (terminator) represent low sun angle pictures, whereas the region near the limb is illuminated by nearly overhead sunlight.

IMPACT CRATERING ON A RAINY DAY

(Instructor's Notes and Answer Key)

OBJECTIVE

To illustrate the way in which planetary surfaces can be dated by analyses of craters, you will create impact features with raindrops and will study the craters formed in order to find out the effect of both continuous impacting of a surface and the angle of illumination on the appearance of the cratered terrain.

MATERIALS

1. Rainy day (or something to duplicate raindrops, such as water sprinkled through a fine-mesh window screen)
2. 4 *petri* dishes (per group)
3. Very fine sand ($100\ \mu\text{m}$)
4. Light source (spot type)
5. Optional: Polaroid camera and film

PRE-LAB

Since the students have probably done other exercises on cratering processes, a special pre-lab is probably not necessary.

LAB

20 minutes. See Fig. 2.8 and Fig. 2.9 for sample results.

POST-LAB

The discussion could center on a comparison of this activity and impact features previously studied.

PROCEDURE AND QUESTIONS

1. Fill each *petri* dish with the fine sand. Place one dish in the light rain for about 5 seconds (or until several craters have formed). How do the crater sizes vary?

During a slow, steady rain, many craters will be similar in size (see Fig. 2.8).

Are the craters clustered together? Do they overlap?

Although craters typically are not clustered, a few clusters do develop. They may overlap.

2. Form a crater in the second dish with your finger. Place this dish in the rain for approximately 30 seconds.

- a. What does the surface look like now?

The large crater formed by the finger becomes degraded (eroded) by the rain impacts.

- b. What happened to the large crater you formed?

It becomes less sharp and distinct.

ORIGINAL PAGE
BLACK AND WHITE PHOTOGRAPH

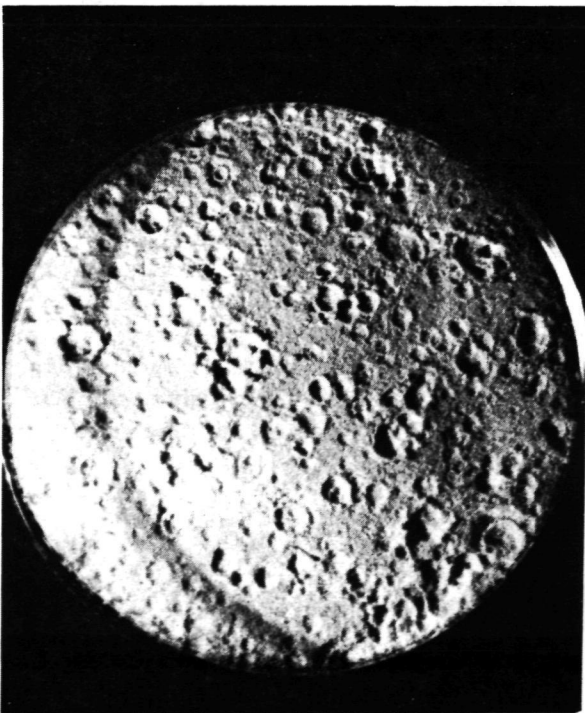
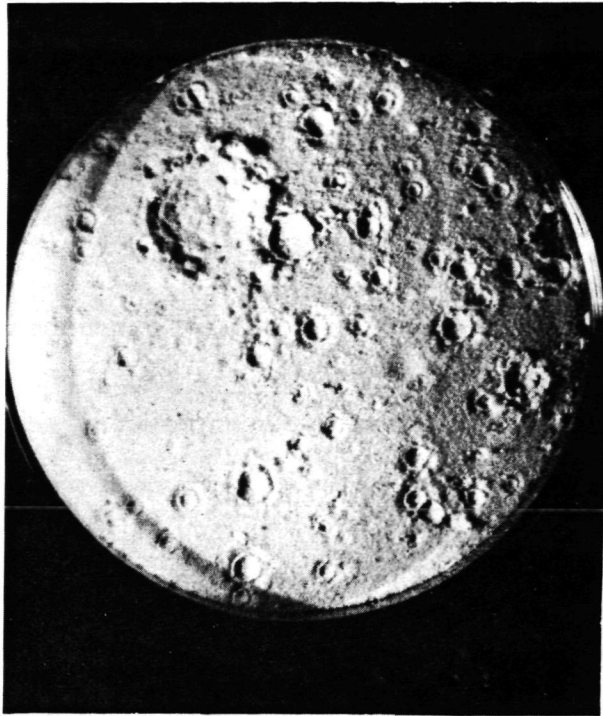

Fig. 2.8: Different sand surfaces exposed for different lengths of time to rain: 5 seconds (upper left), 30 seconds (upper right), 2 minutes (left). The large rain-drop crater in the example at the upper left was produced by a single large drip from the eaves. The longer the sand is exposed to the rain, the more craters are formed. Thus, the number of craters can be used to estimate how long the sand has been in the rain. The concentric appearance of the rain-drop craters was produced by the water soaking into the sand at the point of impact but ejecting loose sand around this point.

- c. What do you suppose would happen to the larger crater if you left it in the rain for 5 minutes (10 times as long)?

It would probably disappear.

- d. Are there more overlapping craters here than in No. 1?

Yes.

- e. Do any of the craters form chains of three or more (three or more in a row)?

Answers will vary.

3. Form another "finger" crater in each of the other two dishes. Place one dish in the rain for two minutes; the other for four minutes.

- a. What has happened to the large craters? Does this agree with your prediction in No. 2?

The large craters become degraded (eroded).

- b. Do you see more tiny craters in either of the dishes? Which dish has the most tiny craters?

Tiny craters should be found in both dishes with the dish exposed for four minutes having the greater number. However, the change in appearance between the surfaces in these two dishes is not as drastic as the change between the previous two surfaces. In other words, the longer the surface is exposed to impact cratering, the more difficult it becomes to distinguish the "age" difference between them. The same problem occurs on certain planetary surfaces where cratering was so extensive that old craters were destroyed almost as rapidly as new craters were formed. This condition is called "equilibrium".

4. The angle of the light affects what you see. During a full Moon, you can see less detail on the Moon's surface than you can during the other phases. Turn off the overhead lights and, with the spot light, shine the light across the surface of the dishes. Try shining the light from the following angles and describe what you see. A slide projector could be used as a light source.

- a. 90° (directly above the craters):

Small craters are nearly invisible. Little detail visible (see Fig. 2.9).

- b. 45° ($\frac{1}{2}$ of a right angle):

Shadows help point out many surface features. Small craters are obvious.

ORIGINAL PAGE
BLACK AND WHITE PHOTOGRAPH

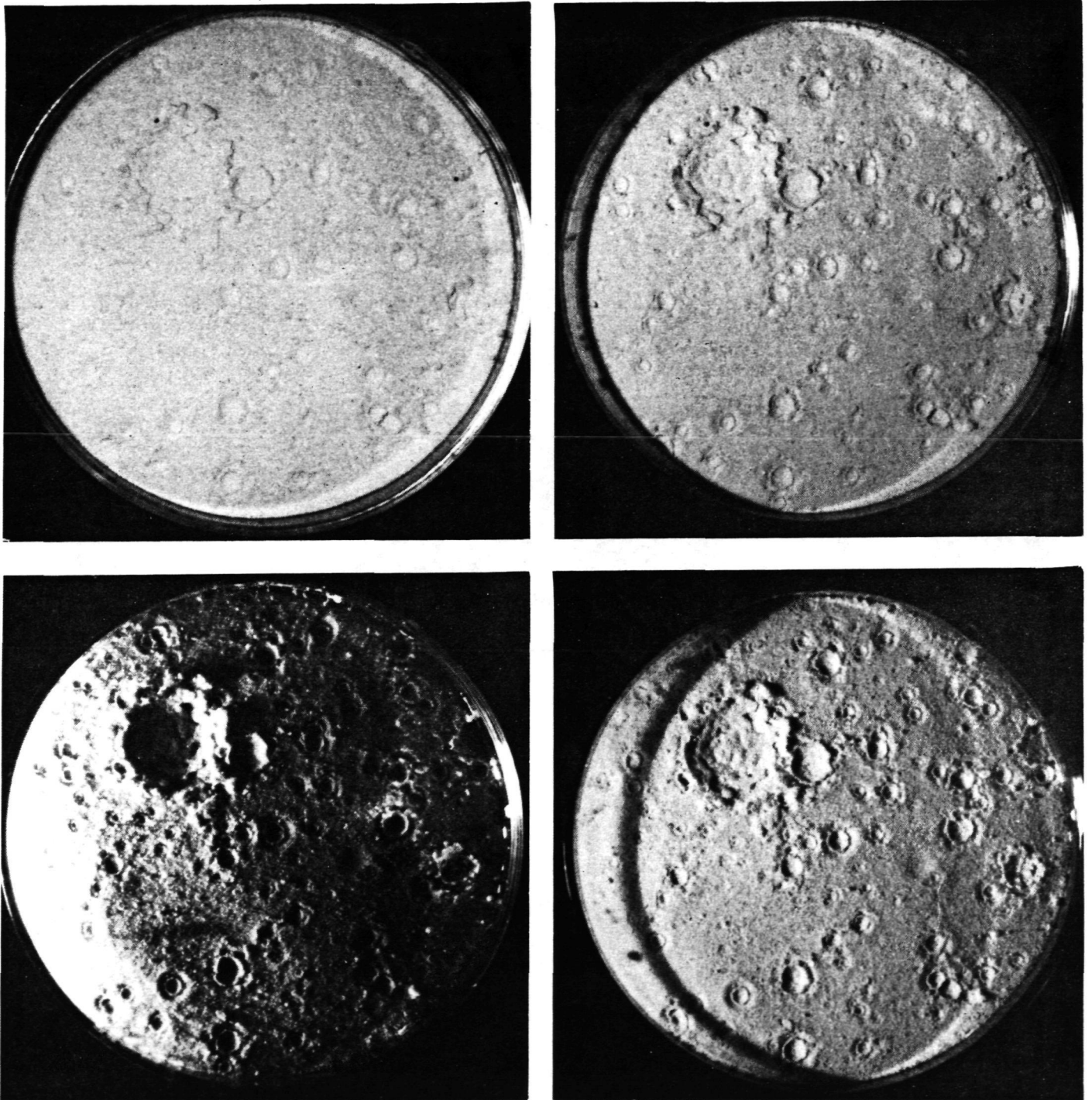

Fig. 2.9: The effect of lighting angle on the identification of surface features. The lighting angle was changed as follows, beginning with the upper left and going clockwise: directly overhead, 60° above horizontal, 30° above horizontal, 5° above horizontal.

c. 20° :

Shadows are long, hiding some small craters.

d. 10° :

Very long shadows. Edge of dish blocks the view of some craters.

*5. Examine Fig. 2.6.

a. List the evidence you see on the Moon for long term impacting.

A variety of crater sizes in various states of preservation, chains of craters, high density of craters per unit area, similarity of terrain at different locations.

b. List the features you see on the Moon that are similar to those produced in the experiment.

Crater chains, variety of sizes of craters, variety of states of preservation, etc.

c. Describe the effects of changing lighting angle in the photo.

Those craters near the terminator are illuminated by low sun angle and show more detail. Those craters near limb are illuminated by a nearly overhead sun and appear "washed out", lacking detail.

ORIGINAL PAGE
BLACK AND WHITE PHOTOGRAPH

UNIT THREE

ACTIVITIES IN AEOLIAN PROCESSES

Wind is an important agent of erosion in many arid and shore regions of the Earth. During wind erosion, small particles are picked up by the wind, bounced along the surface, or rolled, and eventually deposited. The most obvious wind-deposited feature is the DUNE common in some desert areas and seashore regions—places where there is an abundance of sand-sized particles and a prevailing wind direction.

The Earth is not the only planet where wind is important. Venus, with its dense atmosphere and strong winds, may also have wind-induced erosion and depositional features. Photos returned to Earth by Mariner 9 and Viking show that much of the martian surface is covered by windblown features, including numerous dune fields.

In addition to dunes, other wind-related features have been identified on Earth and Mars. The general shapes of these features are similar enough on both planets to give scientists confidence that wind was a common factor in their creation. But the similarity often breaks down when fine details and overall size of the features are considered. The reason for this is clear: although winds blow strongly enough to move small particles on Mars, the "air" is on the average 200 times thinner and made of different gases. Lengths of seasons and local geography are also very different on the planets. Thus, the different aeolian (wind-related) environment on Mars accounts for the variation in wind-related features on the two planets. As of this writing, our knowledge of the aeolian environment on Venus is still too uncertain to make any judgments about wind-related features on that planet.

In the following activities the student will study wind erosion, deposition, and the general effects of wind motions on the planets. The activities are fairly easy for the student to control. However, to ensure best results, a modest investment in time, materials, patience, and tenacity on the part of the instructor is required. The results should prove enjoyable.



Fig. 3.1: NASA LANDSAT photograph E-1127-06060-6. These dunes are part of the Dash-E-Lut sand sea about 200 km east of Kerman in Iran. The width of this dune field is about 65 km; the photo was taken from 917 km altitude on 27 November 1972. North is to the top. Scale is 1 cm = 20 km.

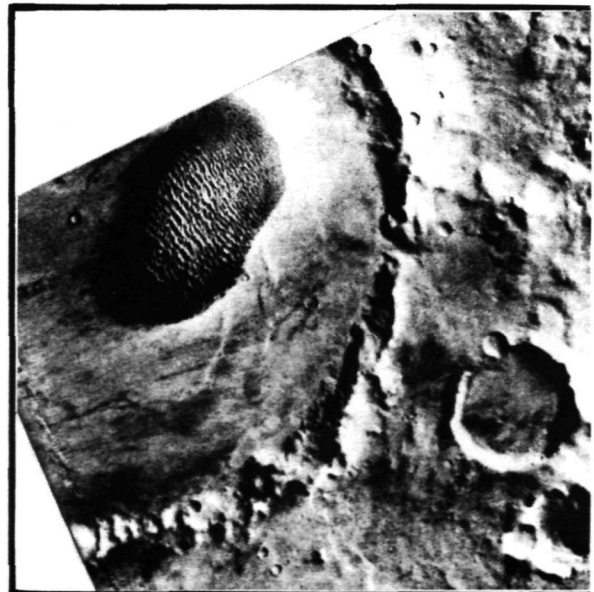

Fig. 3.2: Viking Orbiter photograph 510A46. These dunes on Mars appear remarkably similar to those on Earth (Fig. 3.1). They are located on the floor of the crater Proctor about 48°S, 330°W, some 500 km west of the Hellespontes Mountains. Dune field width is 40 km; north to the top. Scale is 1 cm = 20 km.

AEOLIAN PROCESSES: MARTIAN WIND TUNNEL

OBJECTIVES

1. In this experiment you will demonstrate the process of wind erosion on surface features such as craters and hills.
2. Through photographic interpretation and the wind tunnel activity, you will recognize wind-eroded features on Mars.

MATERIALS

1. Wind tunnel model
2. Container of 100 μ m sand () or super fine sugar () (check appropriate one)
3. Fine strainer or sieve
4. Flat bottomed container 2-4 inches in diameter
5. Spot light (40-60 watt) or strobe
6. Ruler or centimeter scale

PROCEDURE AND QUESTIONS

1. Sprinkle the sand or sugar evenly over the floor of the wind tunnel. Turn on the spot light and shine it through one window. Turn on the fan to low speed and view through the other window.

NOTE: Be certain that nobody stands in front of the fan or at the open end of the wind tunnel. This will disturb the flow of air. If the fan does not begin to move the "sand" within a minute or so, turn the fan up to a higher speed. The movement of sand in this exercise will be slow.

2. Does the sand move?

3. What fan speed was necessary to begin the sand movement?

4. How high above the wind tunnel floor did the sand rise? (measure in centimeters)

5. If you were on a desert and a strong wind began to blow the sand, would you better be able to avoid the sand close to the ground or in a tower?

6. Blown sand is an important cause of erosion and weathering in some parts of the world (and on Mars). Where would the action of blowing sand be strongest, close to the ground or several feet above the ground? Explain.

7. Turn off the fan and insert the strainer or sieve BETWEEN THE FAN AND TUBE CELLS in front of it. Fill the sprinkler (strainer) and tap it so that the sand begins to blow out the holes. Turn the fan on to medium speed (high if it doesn't move) and continue to let the "sand" slowly flow out of the holes in the sieve.
8. How far down the tunnel can you detect sand movement?

9. Turn off the fan and pour the "sand" that is on the container (tunnel) back into the tray. Replace the board and sprinkle an even layer of sand on the tunnel floor. Midway between the two observation windows, pour a small pile of sand through the sieve so that a small cone is formed (about 2 inches high). Place the flat-bottomed container on this pile and slowly turn it until a flat-bottomed crater forms. Remove the container.
10. In this part of the activity, you will be turning the fan on and off periodically to monitor the progress of erosion of the crater. Turn the fan on to high. After a minute, turn off the fan and observe what changes have occurred to the crater and the surrounding area.
11. Sketch what you observed. Where is the sand being deposited (put down) and where is it being eroded? Which is carried farthest, the coarse or the fine sand?

12. Follow the same procedure in Step 10, but allow the fan to blow for 4 more minutes.
13. While the fan is blowing, identify the regions where most of the erosion is occurring.
14. Which direction does the sand move?

15. Based on your observation, sketch what effect the crater has on the wind movement. (Imagine you could see the wind; sketch how you think it would be moving.)

ORIGINAL PAGE
BLACK AND WHITE PHOTOGRAPH

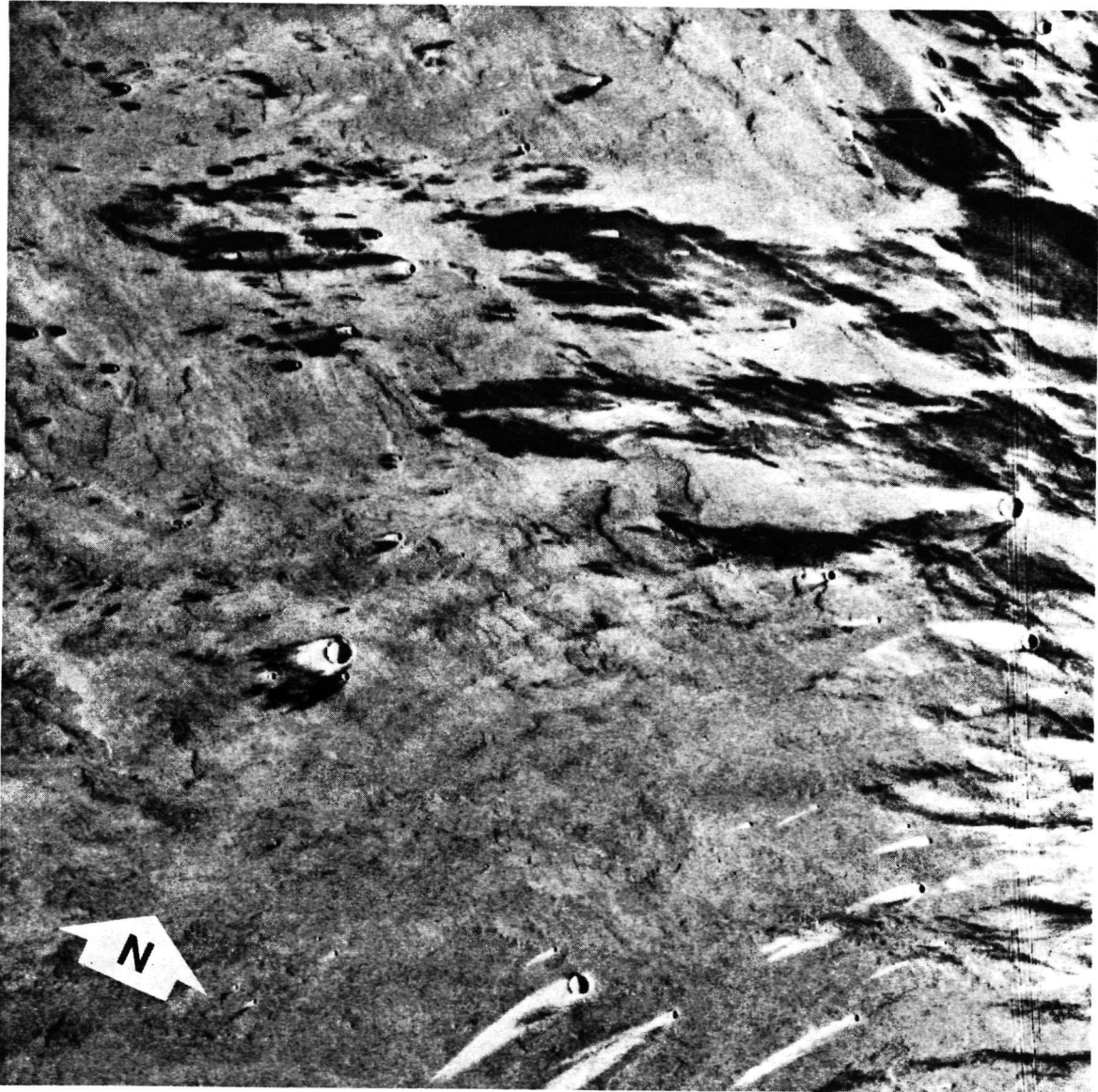

Fig. 3.3: Viking Orbiter photograph 639A62. Wind streaks on Mars located on the Tharsis Plateau, southwest of Arsia Mons. The picture center is approximately 14°S , 129°W . North is not at the top, but in the direction of the superimposed arrow in the lower left. Notice the similarities between this picture and your experimental wind tunnel results. Scale is $1\text{ cm} = 20\text{ km}$.

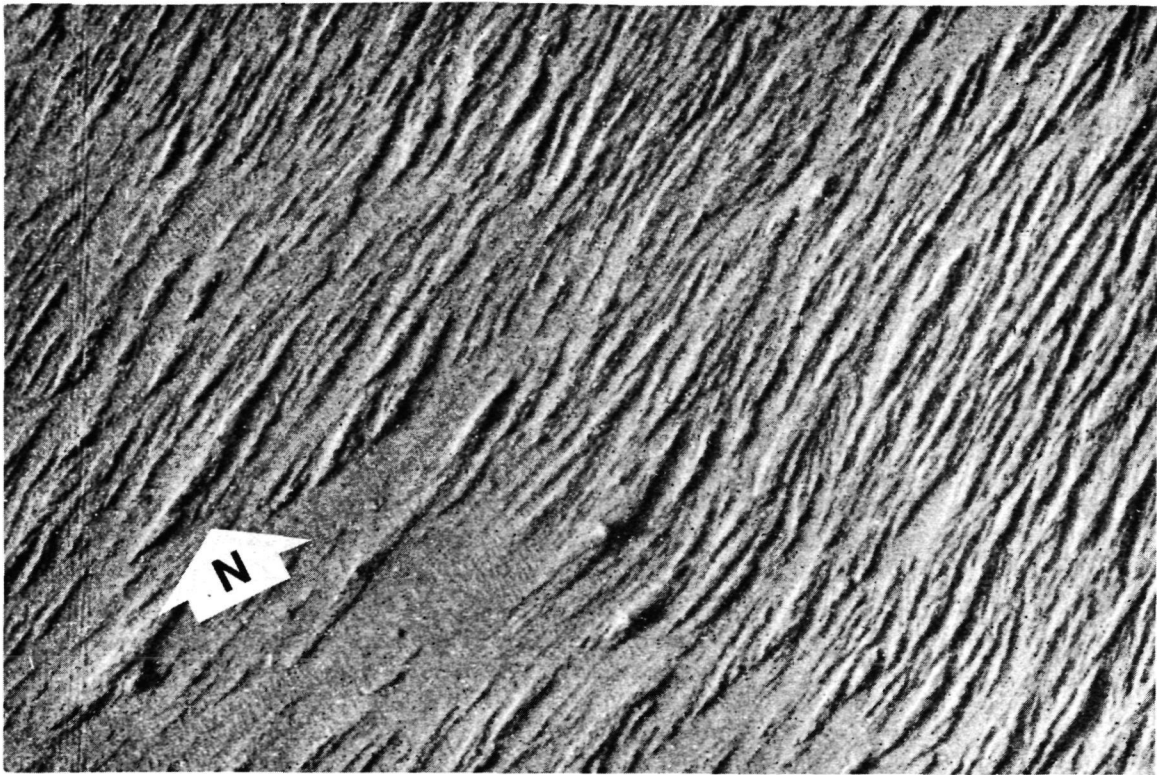

Fig. 3.4: Viking Orbiter photograph 724A31. Equatorial yardangs on Mars located south of Elysium Mons. The picture center is about 3°S, 208°W. North is not at the top, but in the direction of the superimposed arrow. Scale is 1 cm = 1 km.



Fig. 3.5: NASA ERTS (Landsat) satellite photograph 1128-06114-6. These are part of the Namakzar yardangs located 100 km west of the Dash-E-Lut sand dunes (Fig. 3.1) in Iran. The photo was taken on 28 November 1972. North is to the top. Scale is 1 cm = 5 km.

16. Turn off the fan. Remove the sand. Resprinkle the surface with a new layer of sand as you did in Step 9. Form a new cone but this time DO NOT FLATTEN IT. Turn the fan on to high speed. Leave the fan on until most of the material has been removed from around the cone. Describe the shape of the cone now.

.....

17. Leave the fan on until most of the material has been removed from around the cone. Describe the shape of the cone.

.....

.....

18. Look at the photograph of Mars (Fig. 3.3). Do you see anything similar to what you produced in the tunnel? Which direction do you think the wind was blowing? Are the dark areas behind the craters EROSIONAL zones or DEPOSITIONAL zones? "The light areas?"

.....

.....

.....

.....

.....

.....

19. Compare the results of the eroded sand cone to the martian photograph (Fig. 3.4) of the elongated hills. On the Earth, elongated hills develop in desert regions as a result of continuous erosion by sand and wind coming from only one direction. These features are called "yardangs" and their existence on Mars suggests a desertlike climate and long history of wind erosion from prevailing winds. Compare with Fig. 3.5.

.....

.....

.....

.....

.....

.....

AEOLIAN PROCESSES: MARTIAN WIND TUNNEL

(Instructor's Notes)

OBJECTIVES

1. In this experiment you will demonstrate the process of wind erosion on surface features such as craters and hills.
2. Through photographic interpretation and the wind tunnel activity, you will recognize wind-eroded features on Mars.

MATERIALS

1. Wardrobe box from moving company.
2. 3-speed 20" fan
3. Two boxes approximately 6" x 20" x 24"
4. Hexcell material (Hexcell material is closely spaced hexagonal cells of cardboard-like material that is used to even out the flow of the wind. Other possible replacement could be open-ended cardboard tubes tied together.)
5. Wood stripping 8' x 1" x 1.5"
6. String
7. Dark-colored poster board (green)
8. 100 μ m sand (10 lbs.) or 2 lbs. of SUPERFINE sugar
9. Very fine strainer
10. Container to hold sand
11. Flat-bottomed glass (4" diameter petrie dish or 2" diameter glass with smooth bottom)
12. Hollow copper or aluminum tubing (pliable 30" x 1/2")
13. Masking tape
14. Clear plastic wrap (12" wide)
15. 40 or 60 watt lamp, or strobe light
16. Scoop and funnel

REFERENCE ARTICLES

The following articles all may be found in a special issue of the *Journal of Geophysical Research*, vol. 84, No. B14, December 30, 1979, devoted entirely to the scientific investigation of Mars.

Breed, Carol S. et al., Morphology and Distribution of Common "Sand" Dunes on Mars: Comparison with Earth, pp. 8183-8203; a well-illustrated description of aeolian features on Mars.

Tsoar, Haim et al., Mars: The North Polar Sand Sea and Related Wind Patterns, pp. 8167-8182; the aeolian regime at the polar regions of Mars is discussed.

Ward, A. Wesley, Yardangs on Mars: Evidence of Recent Wind Erosion, pp. 8147-8166; nicely illustrated interpretations of the interaction of wind with local martian geology.

PRE-LAB

None required

POST-LAB

Thirty minutes: A post-lab discussion should consider the features formed and how they compare with features on Earth and Mars.

WIND TUNNEL CONSTRUCTION

1. The diagrams show how the tunnel is constructed.

The movers wardrobe box (or similar size box 24" x 20" x 48") is kept intact (do not remove the flaps). Three windows are cut out: one on each side and one on the top (A, B, C).

The two side windows are sealed with clear plastic wrap (e.g., Saran Wrap) and taped from the inside. The width of the plastic wrap determines the height of the window (a little less than 12"); a convenient length is 16".

The top window is left unsealed so that you can look more closely at the sand crater and perhaps take pictures during different stages of the experiment. The clear plastic top of the storage tray can be used as a removable window.

2. Hexcell material is used to distribute the wind more evenly in the tunnel. This material is a honeycomb of hexagonal cells, each about $\frac{1}{2}$ " in diameter. If this material cannot be found, a substitute would be several dozen quart-size milk containers with the ends removed and glued together on their sides, or empty toilet paper rolls.

The hexcell material is cut to the size of the simple wooden frame (E), which keeps the box from collapsing. The frame is made from wood stripping and should fit snugly within the box. An approximate dimension is 20" x 24" with the narrowest portion of the stripping (1") facing the fan.

The hexcell material is attached with string to the frame.

3. A sand sprinkler (F) is constructed from the hollow copper or aluminum tubing.

The tubing is pliable so that it can be turned up at the ends as shown.

Holes ($\frac{1}{8}$ ") are drilled or punched at $\frac{1}{2}$ " spacings. If the holes are punched with a nail, punch through both sides of the tubing and use the exit holes for the bottom.

Funnels (plastic or cardboard) are placed in both ends and act as reservoirs of sand. The sprinkler is placed through the elongated holes in the flaps of the box (F') when indicated in the exercise.

4. Boxes (G, H) are placed on the floor of the wind tunnel in order to raise the floor area to nearer the center of the fan (6" above the floor is sufficient). The sand-filled tray (I) is placed behind these boxes in order to keep them from flying away by the wind and to catch some of the sand after it leaves the posterboard.
5. The dark-colored posterboard provides contrast to the white sand and is removable for different experiments. When placed in the tunnel, be sure that the board (and boxes) goes all the way to the front next to the hexcell material; otherwise, the wind will go underneath the board, which then will become airborne.
6. The fan (K) is placed within the flaps at one end and is directed into the tunnel. A better arrangement would be to place the fan at the other end, thereby drawing the air through; however, this arrangement risks damage to the fan because of the fine sand.
7. Before running the experiment, check for regions experiencing more erosion than others as a result of the design of the fan or the positioning of the hexcell material. In some instances, you may have to move the fan to the side in order to get more even flow.

This can be checked by sprinkling sand across the posterboard and watching for "hotspots" with the fan at medium or high speed. You probably will notice a strong hotspot near the center of the board and near the exit side. This is partly the result of the wind coming off the sides of the tunnel and partly from blowing sand landing in this region. For this reason, all objects placed in the tunnel should be near the front side of the window.

ORIGINAL FILE IS
OF POOR QUALITY

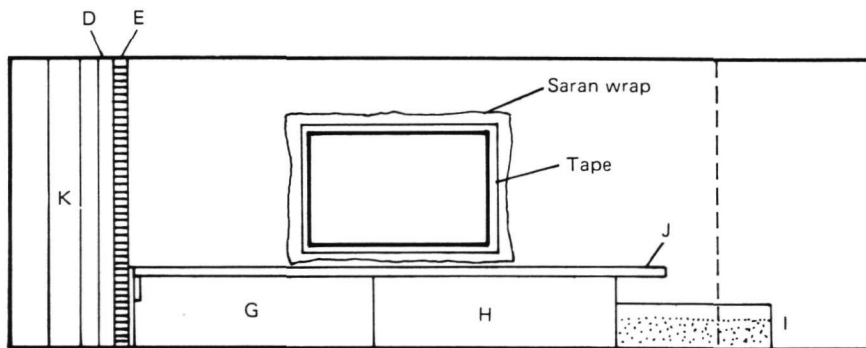
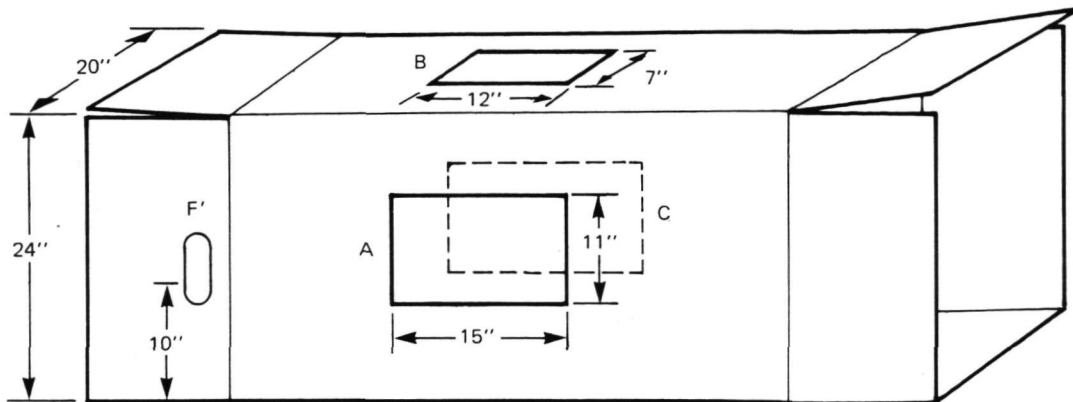

Side view

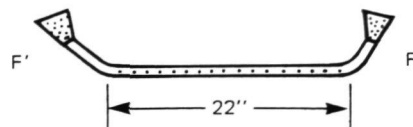

Diagrams showing set-up for wind tunnel experiments.

ORIGINAL PAGE
BLACK AND WHITE PHOTOGRAPH

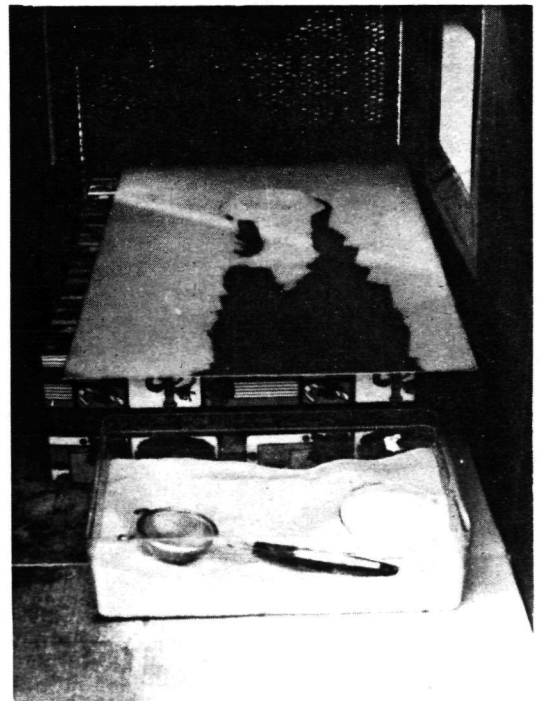
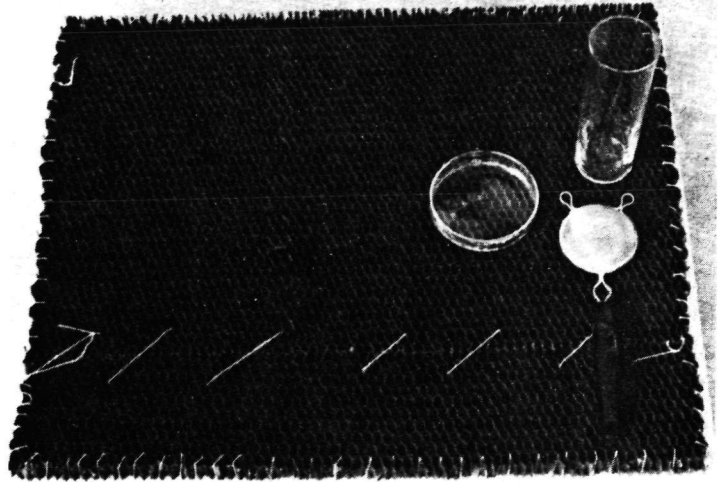
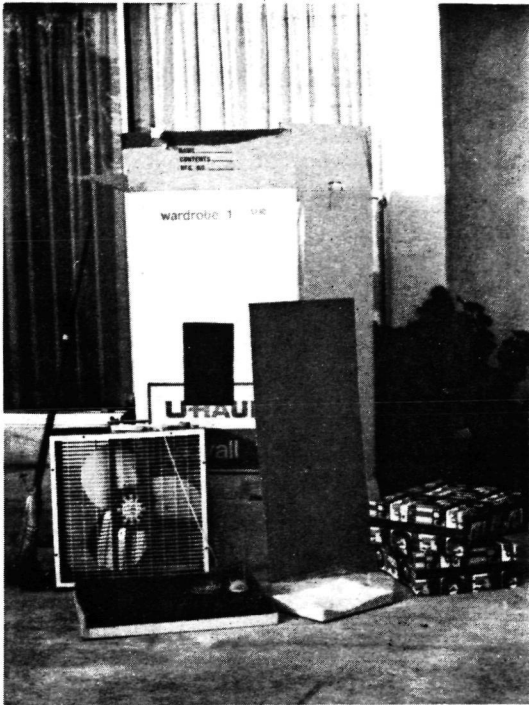

Photographs showing materials for wind tunnel experiments.

8. One final note. The recommended sand size is 100 μm . This is an ideal size for demonstrating sand movement. Finer and coarser sands are more difficult to set in motion. You can use this fact for an extended part of the exercise, in which different sand sizes are used and the wind speeds compared.

The experiment should not be done outside when there is any wind. In the classroom, you might use a deflector approximately 5 feet from the end of the tunnel. This can be constructed by hanging plastic from the back of two side-by-side chairs and taping the plastic to the floor.

AEOLIAN PROCESSES: MARTIAN WIND TUNNEL

(Instructor's Key)

OBJECTIVES

1. In this experiment you will demonstrate the process of wind erosion on surface features such as craters and hills.
2. Through photographic interpretation and the wind tunnel activity, you will recognize wind-eroded features on Mars.

MATERIALS

1. Wind tunnel model
2. Container of 100 μm sand () or super fine sugar () (check appropriate one)
3. Fine strainer or sieve
4. Flat bottomed container 2-4 inches in diameter
5. Spot light (40-60 watt) or strobe
6. Ruler or centimeter scale

PROCEDURE AND QUESTIONS

1. Sprinkle the sand or sugar evenly over the floor of the wind tunnel. Turn on the spot light and shine it through one window. Turn on the fan to low speed and view through the other window.

NOTE: Be certain that nobody stands in front of the fan or at the open end of the wind tunnel. This will disturb the flow of air. If the fan does not begin to move the "sand" within a minute or so, turn the fan up to a higher speed. The movement of sand in this exercise will be slow.

2. Does the sand move?

Yes

3. What fan speed was necessary to begin the sand movement?

Medium for sand, high for sugar.

4. How high above the wind tunnel floor did the sand rise? (measure in centimeters)

Approximately 2 cm.

5. If you were on a desert and a strong wind began to blow the sand, would you better be able to avoid the sand close to the ground or in a tower?

In a tower.

6. Blown sand is an important cause of erosion and weathering in some parts of the world (and on Mars). Where would the action of blowing sand be strongest, close to the ground or several feet above the ground? Explain.

Close to the surface.

**ORIGINAL PAGE IS
OF POOR QUALITY**

7. Turn off the fan and insert the strainer or sieve BETWEEN THE FAN AND TUBE CELLS in front of it. Fill the sprinkler (strainer) and tap it so that the sand begins to blow out the holes. Turn the fan on to medium speed (high if it doesn't move) and continue to let the "sand" slowly flow out of the holes in the sieve.

8. How far down the tunnel can you detect sand movement?

The entire length.

9. Turn off the fan and pour the "sand" that is on the container (tunnel) back into the tray. Replace the board and sprinkle an even layer of sand on the tunnel floor. Midway between the two observation windows, pour a small pile of sand through the sieve so that a small cone is formed (about 2 inches high). Place the flat-bottomed container on this pile and slowly turn it until a flat-bottomed crater forms. Remove the container.

10. In this part of the activity, you will be turning the fan on and off periodically to monitor the progress of erosion of the crater. Turn the fan on to high. After a minute, turn off the fan and observe what changes have occurred to the crater and the surrounding area.

11. Sketch what you observed. Where is the sand being deposited (put down) and where is it being eroded? Which is carried farthest, the coarse or the fine sand?

See Fig. 3.6.

12. Follow the same procedure in Step 10, but allow the fan to blow for 4 more minutes.

13. While the fan is blowing, identify the regions where most of the erosion is occurring.

14. Which direction does the sand move?

Downwind.

15. Based on your observation, sketch what effect the crater has on the wind movement. (Imagine you could see the wind; sketch how you think it would be moving.)

The sketch below represents the aerodynamic characteristics of a crater when wind blows across it from left to right. (Wind stream is in the direction of the large arrows.) Experiments to visualize this model were done at the NASA Ames Research Center.

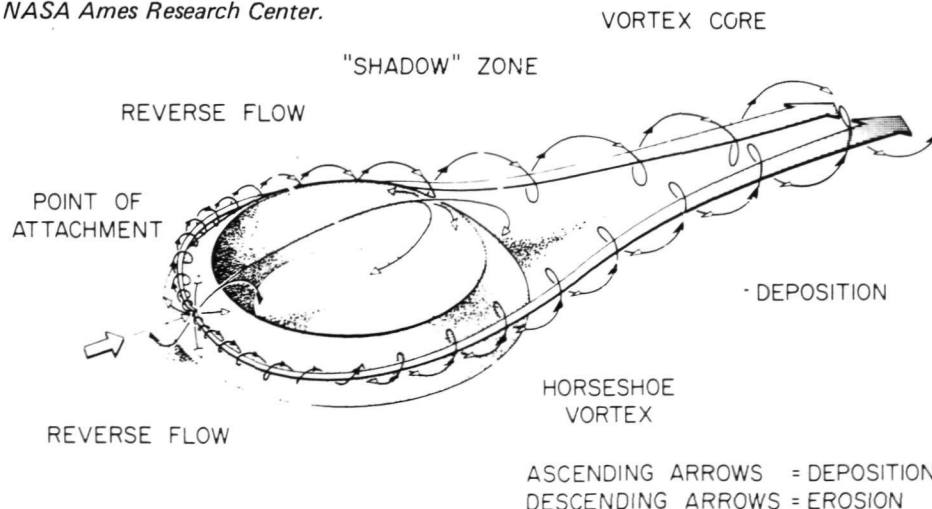

ORIGINAL PAGE
BLACK AND WHITE PHOTOGRAPH

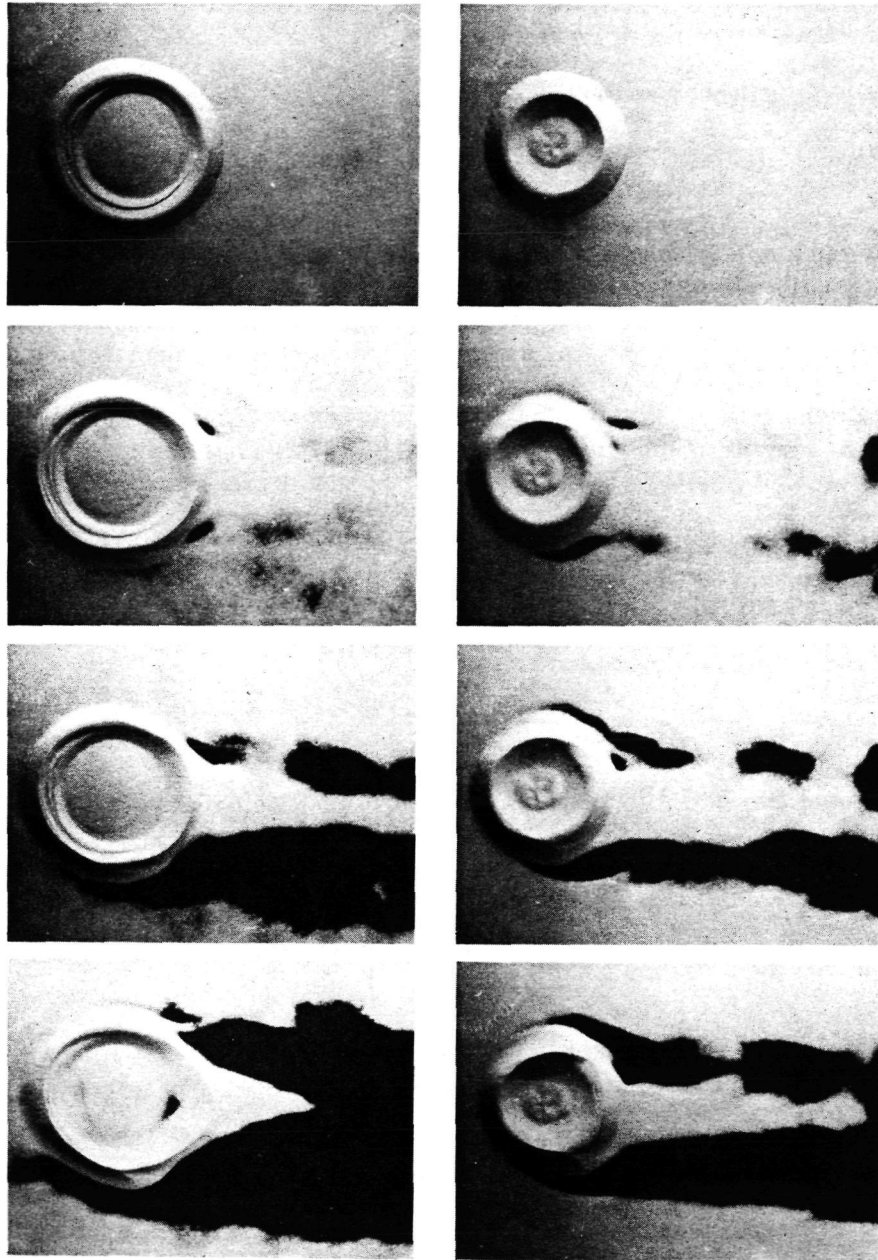

Fig. 3.6: Wind tunnel model craters. The left column of pictures shows a crater formed by a 2" diameter drinking glass pushed into a mound of sand as time progresses from top to bottom. The right column shows wind effects on a crater formed with a 4" diameter petri dish (photos are not to the same scale). The wind is blowing from left to right. Notice that in the second pair of pictures, both craters are developing two zones of erosion that enlarge in the third pair of photos. The dead space in between appearing as a tail of sand in the fourth pair of photos is actually a zone of deposition formed by lateral movement of sand into the region. Notice also that as time progresses, another erosional zone is developing inside the crater on the upwind side of the "back" wall. The crater itself is beginning to develop an aerodynamic shape. The sand in the zones of erosion is probably removed by turbulent vortices formed as the windstream breaks up along the "side" walls.

16. Turn off the fan. Remove the sand. Resprinkle the surface with a new layer of sand as you did in Step 9. Form a new cone but this time DO NOT FLATTEN IT. Turn the fan on to high speed. Leave the fan on until most of the material has been removed from around the cone. Describe the shape of the cone now.

17. Leave the fan on until most of the material has been removed from around the cone. Describe the shape of the cone.

It has become eroded.

18. Look at the photograph of Mars (Fig. 3.3). Do you see anything similar to what you produced in the tunnel? Which direction do you think the wind was blowing? Are the dark areas behind the craters EROSIONAL zones or DEPOSITIONAL zones?

The average, prevailing wind has come from the northeast (from top right toward lower left). The dark areas are probably erosional where bright, surface material has been scoured away exposing darker, underlying rocks. The bright crater tails are most likely depositional where bright surface materials, ponded in craters, has been blown out.

19. Compare the results of the eroded sand cone to the martian photograph (Fig. 3.4) of the elongated hills. On the Earth, elongated hills develop in desert regions as a result of continuous erosion by sand and wind coming from only one direction. These features are called "yardangs" and their existence on Mars suggests a desertlike climate and long history of wind erosion from prevailing winds. Compare with Fig. 3.5.

See the third reference article found in the Instructor's Notes.

UNIT FOUR

PLANETARY ATMOSPHERES

The Earth is not unique in possessing a blanket of air covering its surface. Venus, Mars and the outer planets have dynamic gaseous envelopes. However, none of the other planets or moons has that special combination of gases which sustains life as we know it. Or perhaps it should be said that the special combination of gases on Earth was responsible for the evolution of life as we know it.

A quick glance at the chart of the characteristics of the planets (inside cover) gives several other reasons why planetary atmospheres are different. First, surface gravity, the force which holds down an atmosphere, differs significantly among the planets. Second, the distance from the sun will determine how much energy is available to heat up the gases in a given atmosphere: the closer a planet is to the sun, the more energy is available to propel the lightest atmospheric gases to an average speed exceeding the escape velocity.

There are other factors that do not show up in the chart to explain the differences in planetary atmospheres. We know that the general chemistry and geologic history of each planet differ just enough so that if atmospheres formed by gases escaping from the interiors, the constituents and total pressure are likely to be different. Except for Pluto, the outer planets are, in fact, mostly gases under exotic states of pressure and temperature.



Fig. 4.1: Viking Orbiter photograph 211B24. This spectacular view of a huge dust cloud on Mars is a sample of the abundance of large scale weather disturbances on that planet. The cloud is over 8 km high and nearly 700 km long. It is located over Solis Planum at 17° S, 92° W, south of the great chasm Valles Marineris which is visible at the top of the picture. Valles Marineris is filled with dust clouds. Scientists were able to track the movement of the cloud for several days. It is travelling to the southeast at about 17 m/sec (about 38 mi/hr). North is approximately to the top. Not all monitoring of planets is done by photography. This cloud, for example, was identified as a dust cloud by its thermal properties. A special telescope detected its radiation in long (heat emitting) wavelengths. A second device used to detect water vapor helps confirm this finding. Non-photographic instruments are extremely important for planetary exploration.

ORIGINAL PAGE
BLACK AND WHITE PHOTOGRAPH

Name

Class Date

CORIOLIS EFFECT

OBJECTIVES

By photographing the path of an air puck as it proceeds across a turntable, you will demonstrate the Coriolis Effect.

MATERIALS

1. Polaroid camera with ASA 3000 black and white film
2. Strobe light
3. Photo tripod
4. Air puck

PROCEDURE AND QUESTIONS

1. Check to make sure the equipment is set up as indicated by the instructor (the strobe should be located about 1 meter from the turntable and at the same level as the turntable).
2. For the first photograph, the tripod and the camera are off the turntable. As a result, your frame of reference (in this case the camera) — the point from which you are viewing — is disconnected from the rotating turntable. This is similar to what you would see if you were high above the north pole and watching a rocket or an airplane fly across the polar region. Practice gliding the puck across the spinning turntable without hitting the tripod legs.

After several practices, you should be ready for your first photo:

- a. Set the camera and focus it.
 - b. Turn on the strobe light and set it for maximum flash rate.
 - c. Fill the air puck.
 - d. Turn off the room lights.
 - e. Spin the table counterclockwise.
 - f. Start the exposure just before the air puck is pushed across the turntable and then stop the exposure as the puck slides off the turntable.
3. What path do you think the puck will take across the table?
Straight, to the right, to the left
 4. What path does the air puck take in the photo?
Straight, to the right, to the left

5. Counterclockwise rotation: In this part of the activity, the camera and tripod are placed on the turntable. So now, your frame of reference – the camera – will be connected to the rotating turntable. This is similar to what you normally see. You are on a “turntable” (the Earth), which is spinning with a counterclockwise motion.

Place the tripod legs in the metal holders on the turntable; these will help keep the tripod from falling off as the table spins.

Practice giving the air puck a quick shove while the turntable rotates. Then proceed with the photo sequence:

- a. Set the camera and focus it.
- b. Turn on the strobe light and set it for maximum flash rate.
- c. Fill the air puck.
- d. Turn off the room lights.
- e. Spin the table in a counterclockwise direction.
- f. Start the exposure just before the air puck is pushed across the turntable, then stop the exposure as the puck slides off the turntable.

What path does the air puck take this time:

Straight _____, to the right _____, to the left _____

6. Is this the path the puck really took? Explain. Look at the photo and note both the direction the puck was shoved and the direction of rotation of the turntable.

.....
.....
.....
.....

7. Clockwise rotation: Again, the viewer’s frame of reference is connected to the turntable, but this time the rotation is clockwise. Follow the same procedure as in No. 5, only this time the table should be rotated in a CLOCKWISE fashion.

What path does the puck take now:

Straight _____, to the right _____, to the left _____

How does it compare to the counterclockwise rotation?

.....

8. Look at the photo and note the direction of the moving puck and the direction of rotation of the turntable.

a. Which way would the turntable appear to rotate if you were looking from below?

.....

b. Which way would the puck appear to move?

.....

9. If you are on the rotating turntable, the puck APPEARS to have changed its direction, as if acted on by a "force." This IMAGINARY "force" is called the CORIOLIS FORCE and the curve of the puck's path is due to the CORIOLIS EFFECT. As you saw in the first photograph, the puck DID NOT actually experience a "force" as it crossed the rotating turntable. It merely APPEARED to experience a "force" because the viewing position (frame of reference) was moving with respect to the actual straight path of the puck.

For counterclockwise motion, the "force" APPEARS to pull the puck to the right of the path; for clockwise motion, it APPEARS to pull the puck to the left.

This same Coriolis "effect" also affects the motion of ocean currents, aircraft, rockets, and even very large ships.

10. Examine the photograph of windstreaks on Mars (Fig. 4.2). In which direction was the wind blowing?

.....

11. Which side (left or right) does the wind seem to be deflected with respect to its direction (that is, which way does the Coriolis "force" seem to act)?

.....

12. Mars, like the Earth, rotates counterclockwise (as seen from above the north pole) once in about 24 hours.

a. How do you explain this deflection TO THE LEFT?

.....

.....

b. In which martian hemisphere, the northern or southern, was this photo made (Fig. 4.2)?

.....

ORIGINAL PAGE
BLACK AND WHITE PHOTOGRAPH

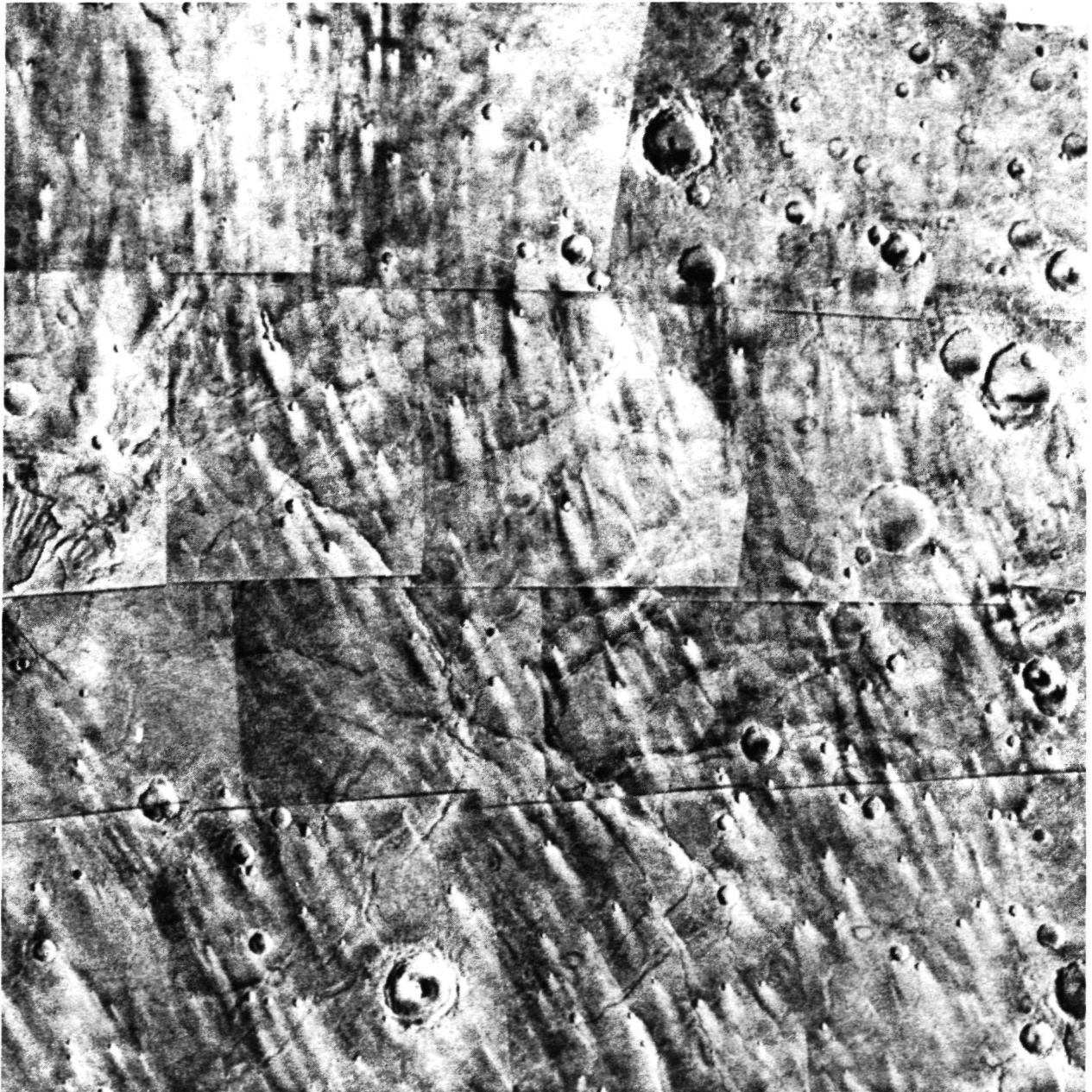

Fig. 4.2: Viking Orbiter mosaic 211-5478, rev 326A; cratered terrain mapping. Centered at 20°S , 250°W , this mosaic is of a region on Mars called Hesperia Planum, site of much aeolian activity. Note the bright streaks associated with some of the craters. They may be used as wind direction indicators as the wind tunnel activity (Unit Three) demonstrated. North is to the top.

CORIOLIS EFFECT

ORIGINAL PAGE IS
OF POOR QUALITY

(Instructor's Notes)

SET-UP PROCEDURE

1. Place the round table top on the turntable. Cut the black posterboard into a circle of diameter 28" and center it on the round table top.
2. Check for centering of the turntable and table top by spinning the turntable.
3. Glue the metal finger pulls as shown in the illustration for Set-up B (these help to keep the tripod from sliding off the turntable).
4. Place the strobe light approximately 1 meter from the turntable. Set the strobe on a box or books in order to bring the light to the same level as the turntable top.
5. When the tripod is placed on the turntable, the "rear" tripod leg should be adjusted so that it is slightly shorter than the other legs. This permits centering the camera above the turntable.
6. Set the camera for a time exposure:
 - a. On automatic cameras set for "Indoors without Flash"
 - b. Place exposure control on lens to "Darker"
 - c. Film speed setting: 75 (even though you will use 3000 speed film)

Any polaroid camera will work if it permits time exposures and can be focused to approximately 1 meter (3 feet).

7. There is nothing magical or mandatory about the arrangements; they are simply convenient. In each set-up, the "pusher" and the photographer should practice coordinating their movements before turning on the strobe light and taking the picture. The goal is to push the air puck across smoothly and rapidly while the turntable is rotating (≈ 1 rev/5-10 sec). The pusher should place the puck ON the surface and have a target on the other side. That is, the puck should not be thrown or dropped onto the surface.

SET-UP A: TRIPOD OFF THE TURNTABLE

Fill the air puck. The pusher can start the turntable rotating and shove the puck across just after the cameraman has started the time exposure. The puck will fall off the turntable on the other side.

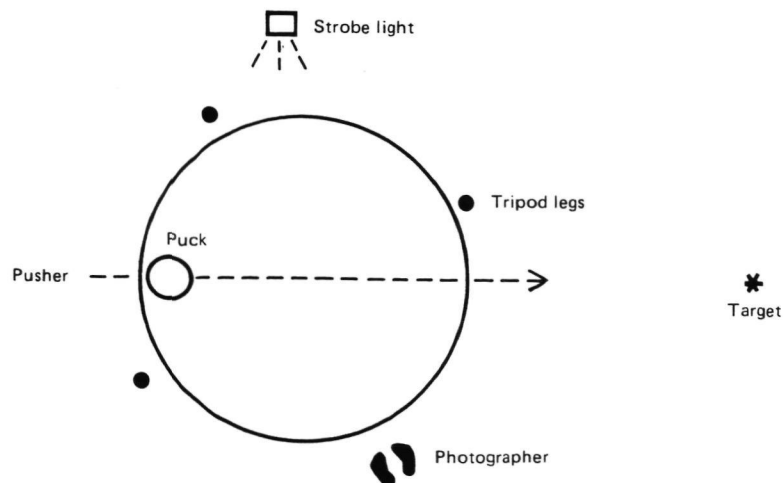

SET-UP B: TRIPOD ON THE TURNTABLE; COUNTERCLOCKWISE ROTATION

Because the camera now will rotate during the time exposure, the photographer (rather than the pusher) should control the motion of the turntable. This is easily done and controlled. In practice, the turntable completes only about $\frac{1}{4}$ -turn during the time the puck crosses the surface and the exposure is completed. The photographer begins to rotate the camera and platform, ready to start the exposure. As soon as the platform begins to rotate smoothly, start the exposure and release the puck. Practice this a few times before you photograph it.

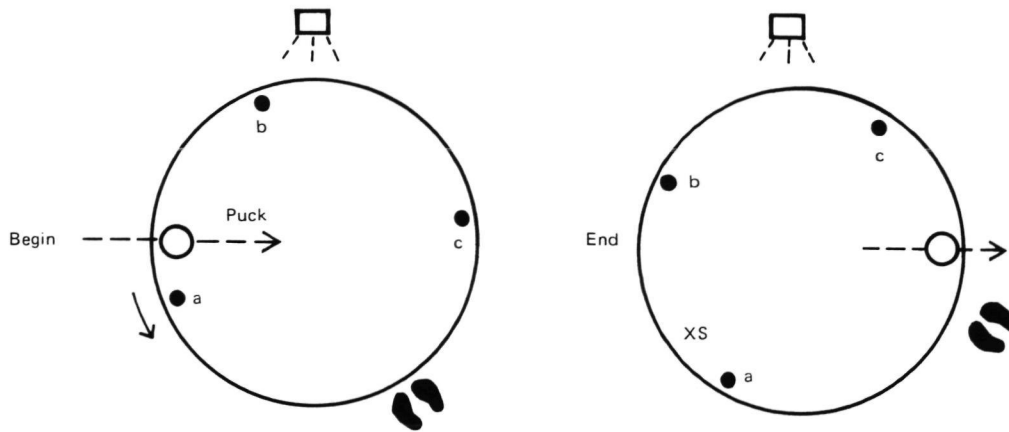

SET-UP C: TRIPOD ON THE TURNTABLE; CLOCKWISE ROTATION

This is essentially the same as set-up B, except the turntable is spinning in the opposite direction. Remember to have the puck on the turntable surface so that the turntable will rotate a little beneath the puck before shoving it towards the opposite side.

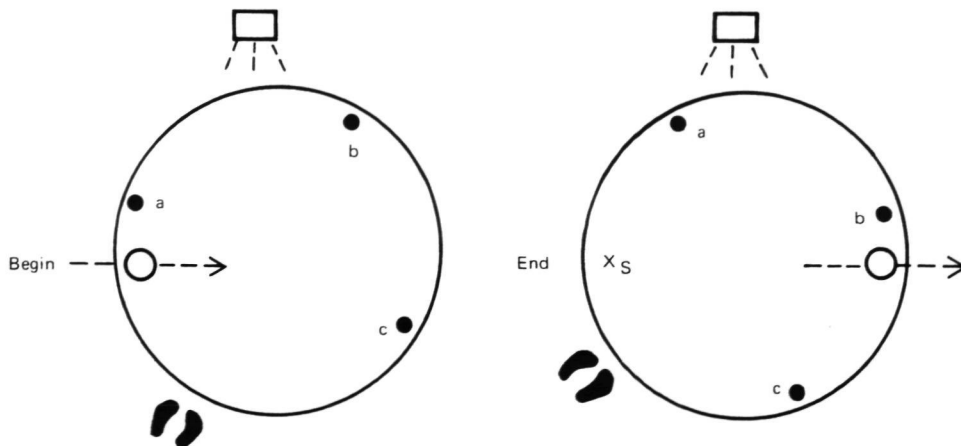

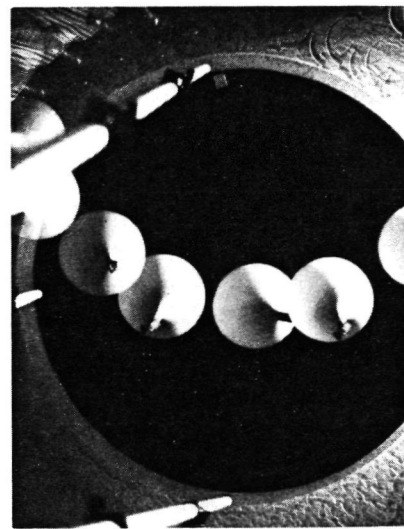
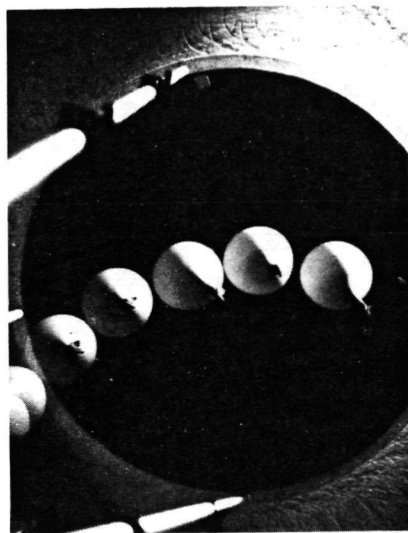
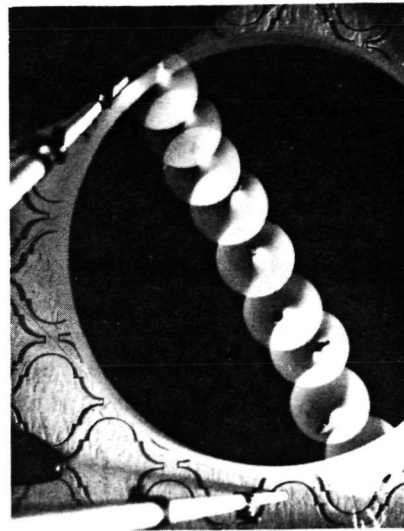
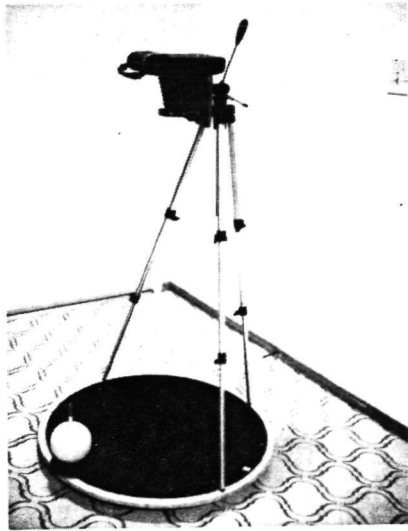

—Upper Left: Laboratory set-up for atmospheric circulation exercise. Polaroid camera is attached to tripod that sits on 30" diameter (3/4" thick) particle board with black posterboard. Everything rests on large storage turntable. Air puck is used for frictionless movement across rotating board.

—Upper Right: Strobe-light photograph of air puck as it travels across rotating turntable. The tripod and camera are off the turntable and are in the same frame of reference as the air puck.

—Lower Left: Strobe-light photograph of air puck with tripod and camera attached to counterclockwise-rotating turntable. Air puck appears to veer to the right of its direction of movement because the camera is rotating counterclockwise relative to the air puck.

—Lower Right: Strobe-light photograph of air puck with tripod and camera attached to clockwise-rotating turntable. Air puck appears to veer to the left of its direction of movement because the camera is rotating clockwise relative to the air puck.

CORIOLIS EFFECT

(Instructor's Key)

3. What path do you think the puck will take across the table?

Straight _____ , to the right _____ , to the left _____

Answers will vary.

4. What path does the air puck take in the photo?

Straight _____^x _____ , to the right _____ , to the left _____

The air puck takes a straight path. See Page 86. The tripod and camera are in the same frame of reference as the air puck—independent of the turntable.

5. What path does the air puck take this time?

Straight _____ , to the right _____^x _____ , to the left _____

The air puck appears to be moving to the right because the camera is rotating counterclockwise relative to the air puck. This is what actually occurs in the northern hemisphere.

6. Is this the path the puck really took? Explain. Look at the photo and note both the direction the puck was shoved and the direction of rotation of the turntable.

No, this is the APPARENT path. The puck actually moved in a straight line. It appears to move to the right because the camera is rotating counterclockwise relative to the air puck.

7. What path does the puck take now:

Straight _____ , to the right _____ , to the left _____^x

How does it compare to the counterclockwise rotation?

The puck moves to the left, opposite to the counterclockwise rotation.

8. Look at the photo and note the direction of the moving puck and the direction of rotation of the turntable.

- a. Which way would the turntable appear to rotate if you were looking from below?

Counterclockwise—opposite.

- b. Which way would the puck appear to move?

The puck would appear to move to the right.

10. Examine the photograph of wind streaks on Mars (Fig. 4.2). In which direction was the wind blowing?

The wind was blowing from north to south, or top to bottom.

11. Which side does the wind seem to be deflected with respect to its direction (that is, which way does the Coriolis "force" seem to act)?

The answer will depend on the student's orientation of the photograph. Deflection is to the left.

12. Mars like the Earth, rotates counterclockwise (as seen from above the north pole) once in about 24 hours.

- a. How do you explain this deflection TO THE LEFT:

This area is in the southern hemisphere of Mars. The windstreaks indicate a northerly wind curving to the left due to the Coriolis effect.

- b. In which martian hemisphere, the northern or southern, was this photo made (Fig. 4.2)?

Note that neither the geographic direction of the wind nor the location of the region are necessary in order to discover that the photograph was taken in the SOUTHERN HEMISPHERE. The only information needed is that Mars rotates counterclockwise and that the wind was deflected to the left.

Name _____

Class _____ Date _____

CORIOLIS EFFECT – DEMONSTRATION I

PART A: CAMERA STATIONARY

1. What path does the air puck take in the photograph?

Straight _____, to the right _____, to the left _____

PART B: COUNTERCLOCKWISE ROTATION

1. What path does the air puck take in this photograph?

Straight _____, to the right _____, to the left _____

2. Is this the path it really took? Explain.

.....
.....
.....

PART C: CLOCKWISE ROTATION

1. What path does the puck take?

Straight _____, to the right _____, to the left _____

2. How does it compare to the counterclockwise rotation?

.....
.....

3. Which way would the turntable appear to rotate if you were looking from below?

.....

4. Which way would the puck then appear to move?

.....
.....

PART D: WIND MOTION

1. Based on Fig. 4.2 showing windblown streaks associated with craters, in which direction was the wind blowing?

.....

2. Which side (right or left) does the wind seem to be deflected with respect to its direction; that is, which way does the Coriolis "force" seem to act?

3. In which martian hemisphere, the northern or southern, was this photo made?

4. Draw the path that a north-blowing wind should take on the surface of the Earth in the northern hemisphere.

5. Draw the path that a southerly wind would take in the northern hemisphere.

CORIOLIS EFFECT – DEMONSTRATION I

(Instructor's Key)

PART A: CAMERA STATIONARY

1. What path does the air puck take in the photograph?

Straight^x....., to the right, to the left

With no rotation, the puck should move straight across the table.

PART B: COUNTERCLOCKWISE ROTATION

1. What path does the air puck take in this photograph?

Straight, to the right^x....., to the left

2. Is this the path it really took? Explain.

The air puck appears to be moving to the right because the camera is rotating counterclockwise relative to the air puck. The puck is actually moving along an approximately straight path.

PART C: CLOCKWISE ROTATION

1. What path does the puck take?

Straight, to the right, to the left^x.....

2. How does it compare to the counterclockwise rotation?

The puck moves to the left, opposite to the counterclockwise rotation.

3. Which way would the turntable appear to rotate if you were looking from below?

Counterclockwise—opposite.

4. Which way would the puck then appear to move?

The puck would appear to move to the right.

PART D: WIND MOTION

1. Based on Fig. 4.2 showing windblown streaks associated with craters, in which direction was the wind blowing?

The wind was blowing from the north to the southeast, or top to bottom.

2. Which side (right or left) does the wind seem to be deflected with respect to its direction; that is, which way does the Coriolis "force" seem to act?

The wind is deflected to the left.

3. In which martian hemisphere, the northern or southern, was this photo made?

This photograph was taken in the martian southern hemisphere.

4. Draw the path that a north-blowing wind should take on the surface of the Earth in the northern hemisphere.

The path should show a deflection to the right.

5. Draw the path that a southerly wind would take in the northern hemisphere.

Again, the deflection would be to the wind's right.

C-2

CORIOLIS EFFECT – DEMONSTRATION II

OBJECTIVE

By plotting the motion of an object across the surface of both moving and non-moving spheres, you will demonstrate the real and apparent motions of objects moving across the Earth's surface. This motion is known as the Coriolis Effect.

MATERIALS

1. Large markable globe or turntable covered with paper (markable)
2. Chalk or crayon

PROCEDURE AND QUESTIONS

1. With the large globe resting on a table and its axis vertical, draw a straight line from the north pole (or center of the turntable) to the equator (edge of turntable). This shows the path of an object moving southward from the north pole on a NON-ROTATING planet.
2. In what way does this fail to show what is really happening to objects moving over the Earth's surface?

.....

.....

.....

3. Repeat Step No. 1, but this time rapidly rotate (spin) the globe (or turntable) in a counter-clockwise direction. Draw the straight line again from the north pole to the equator while the globe is spinning.
4. Describe the line formed.

.....

.....

5. Did the chalk actually follow a straight path?

.....

6. What does this demonstration imply about the motion of objects moving over the Earth's surface?

.....

.....

.....

7. Examine Fig. 4.2. The streaks shown here are caused by the prevailing wind over this part of Mars.

a. Do the streaks form a straight path?

.....

b. What does the shape of the wind streaks indicate about the existence of a Coriolis Effect on Mars?

.....

.....

c. Does Mars rotate?

.....

CORIOLIS EFFECT – DEMONSTRATION II

(Instructor's Notes and Answer Key)

OBJECTIVE

By plotting the motion of an object across the surface of both moving and non-moving spheres, you will demonstrate the real and apparent motions of objects moving across the Earth's surface. This motion is known as the Coriolis Effect.

MATERIALS

1. Large markable globe or turntable covered with paper (markable)
2. Chalk or crayon

PROCEDURE AND QUESTIONS

1. With the large globe resting on a table and its axis vertical, draw a straight line from the north pole (or center of the turntable) to the equator (edge of turntable). This shows the path of an object moving southward from the north pole on a NON-ROTATING planet.
2. In what way does this fail to show what is really happening to objects moving over the Earth's surface?

In this model, the "Earth" is not rotating.

3. Repeat Step No. 1, but this time rapidly rotate (spin) the globe (or turntable) in a counter-clockwise direction. Draw the straight line again from the north pole to the equator while the globe is spinning.
4. Describe the line formed.

This line will show a deflection to its right. This deflection is influenced by the speed of the spin.

5. Did the chalk actually follow a straight path?

Yes, the curve is due to the rotation of the sphere.

6. What does this demonstration imply about the motion of objects moving over the Earth's surface?

Objects moving over the Earth's surface (over long distances) appear to be deflected due to the Earth's rotation. This is only an apparent deflection, however. The objects are really following an approximately straight path.

7. Examine Fig. 4.2. The streaks shown here are caused by the prevailing wind over this part of Mars.

a. Do the streaks form a straight path?

No.

b. What does the shape of the wind streaks indicate about the existence of a Coriolis Effect on Mars?

There must be a Coriolis force on Mars.

c. Does Mars rotate?

Yes.

Name

Class Date

STORM SYSTEMS

OBJECTIVES

1. By examining photographs of the Earth, Mars, and Jupiter, you will recognize the influence of the Coriolis effect on wind circulation patterns.
2. By examining additional photographs, you will recognize other weather systems on the three planets.

MATERIALS

World maps

PROCEDURE AND QUESTIONS

Atmospheric circulation has long been known to be caused by differences in heating between the poles and equator. On an ideal non-rotating Earth warm air would rise over the equatorial regions lowering the air pressure there. Air would then circulate northward to the cool, polar regions where it would sink, increasing the air pressure locally. To complete the cycle the cold, high pressure air would travel southward at ground level to return to the equator. This simplified pattern of circulation (Fig. 4.3) is complicated by the spinning of the Earth, breaking the circulation into several cells from poles to equator. But it is nonetheless true that air moves from regions of high pressure to regions of low pressure. The pressure difference, or gradient, is the driving force, but other effects prevent the trajectory of a given mass of air from being a direct one from high to low. Friction between the ground and the air modifies its motion. But the Coriolis effect, as you saw in the preceding activity, has the greatest influence by deflecting air masses to the right in the northern hemisphere and to the left in the southern hemisphere. Figure 4.4 shows this effect.

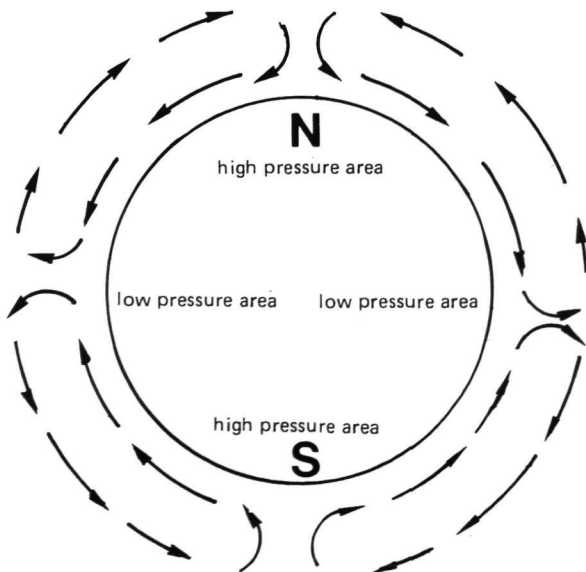

Fig. 4.3: An idealized pattern of air circulation on a model planet. Although completely unrealistic, a simple pattern of airflow would soon develop over a planet as shown if the planet were not spinning and the axis were at right angles to the orbital plane. The Sun would heat the planet most strongly at the sub-solar point, the equator. Air would rise and lower the pressure locally. Colder, denser air would sink at the poles, raising the air pressure locally.

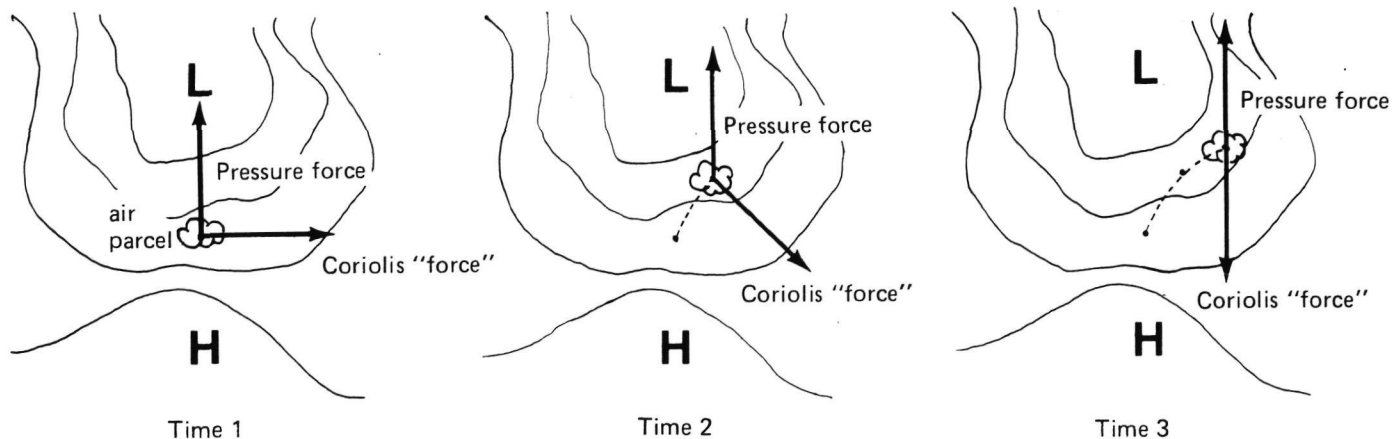

Fig. 4.4: As an arbitrary small mass of air, called an air parcel, moves under the influence of a pressure gradient, its path is not a direct one from high to low. The curved lines around the low pressure center are points of equal pressure, or isobars. They are like contours of topography, where the low pressure center can be considered a "well" or sink for air, and the high pressure center can be considered a ridge or source of air. The air parcel is deflected to the right in the northern hemisphere as time progresses. Thus, the final motion of an air parcel is nearly parallel to the isobars, rather than crossing them directly. In the southern hemisphere, the mirror image of the diagram is observed.

The cyclonic storm is the fundamental mechanism for turbulent, inclement weather on Earth. Cyclones, not to be confused with tornadoes, are huge, well-organized low pressure centers which develop along boundaries between air masses. High pressure cells are called anticyclones. As the cyclone intensifies, so does weather activity along the boundary, or front. The motion of air parcels on Earth, as described in Figure 4.4, generate such low pressure centers. Air parcels can approach low pressure cells from all directions. Because of the Coriolis deflection a circulation of winds is set up around the low pressure centers. Figure 4.5 shows how the circulation begins. The net result is a counterclockwise spiral of air parcels into the low center in the northern hemisphere, and a clockwise spiral in the southern hemisphere.

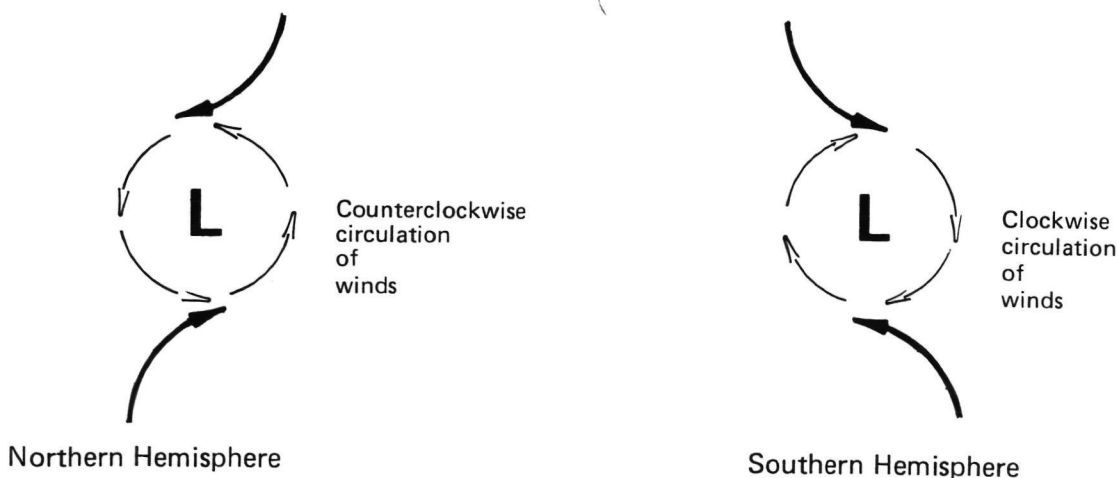

Fig. 4.5: A simplified schematic showing how low pressure cells (cyclones) develop. Air parcels heading toward the lows are deflected by the Coriolis effect and set up the circulation patterns shown.

ORIGINAL PAGE
BLACK AND WHITE PHOTOGRAPH

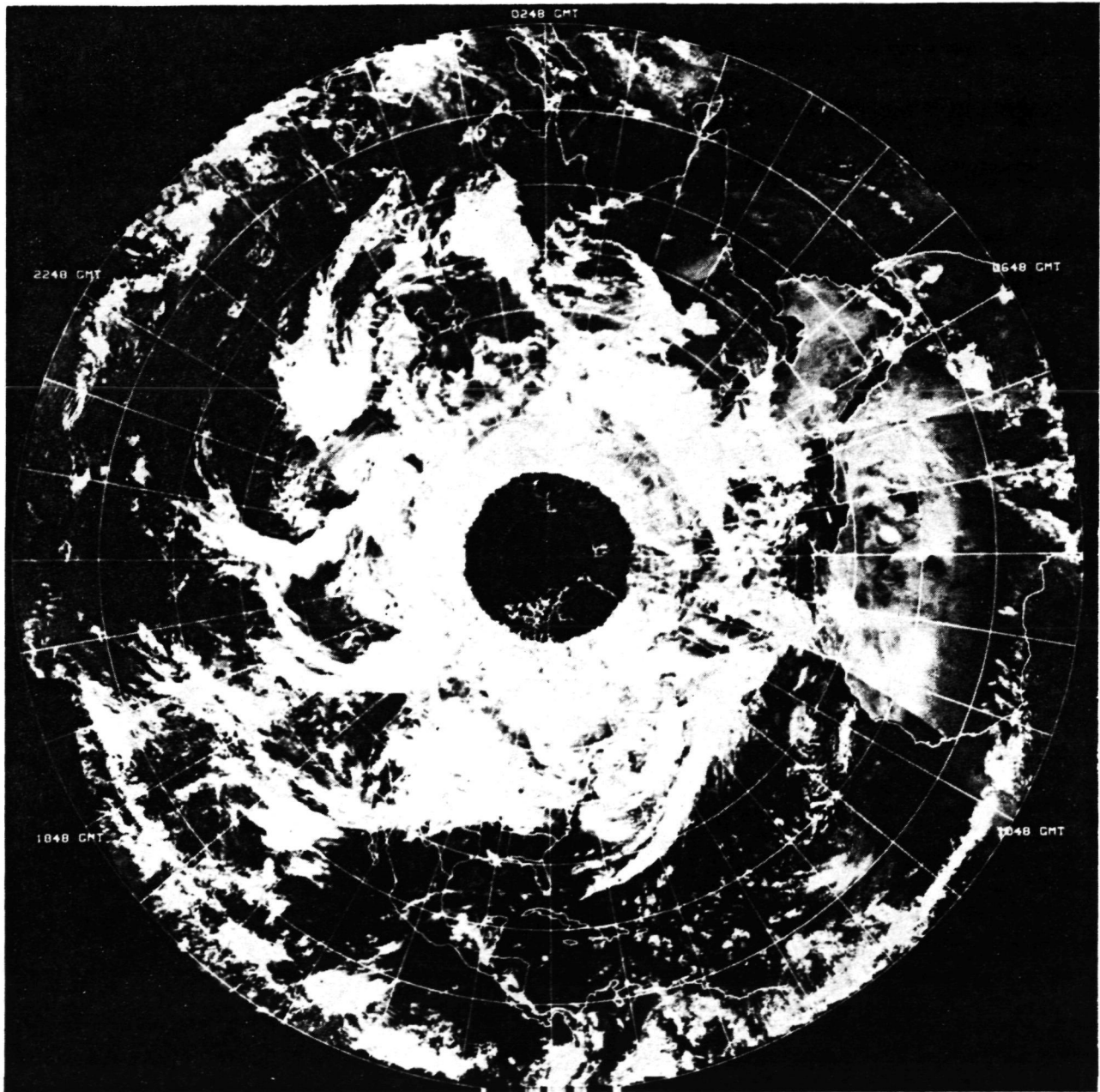

Fig. 4.6: National Oceanic and Atmospheric Administration satellite global photograph 1134/1145. The Earth's northern hemisphere taken 14-15 February 1975. North America is at the bottom. North Pole in center.

ORIGINAL PAGE
OF TECH. QUALITY

1. Examine the NOAA satellite photomosaic of the northern hemisphere (Fig. 4.6). The clouds appear to form tightening spirals to the north. Examine in particular the spiral on the 2248 GMT meridian (left and slightly above center). These spirals are low pressure cells or cyclones. Surface winds converging into the low are affected by the Coriolis force (compare with Fig. 4.5).

a. Which way do the spirals appear to be tightening, clockwise or counterclockwise?

.....

b. Why?

.....

.....

c. What do you think the long tail of clouds attached to the spiral represents?

.....

d. What kind of weather is likely to be associated with this cloud pattern?

.....

2. In which direction does Earth rotate as seen in Figure 4.6?

.....

3. Why do you think weather systems move from west to east? In other words, why does a storm over California end up in Virginia in a few days?

.....

.....

4. Examine the NOAA satellite photomosaic of the southern hemisphere (Fig. 4.7).

a. Notice the well-developed spiral of clouds southwest of Australia (off the coast of Antarctica below center). What is this feature?

.....

b. Which way does the cloud spiral tighten?

.....

c. Why?

.....

ORIGINAL PAGE
BLACK AND WHITE PHOTOGRAPH

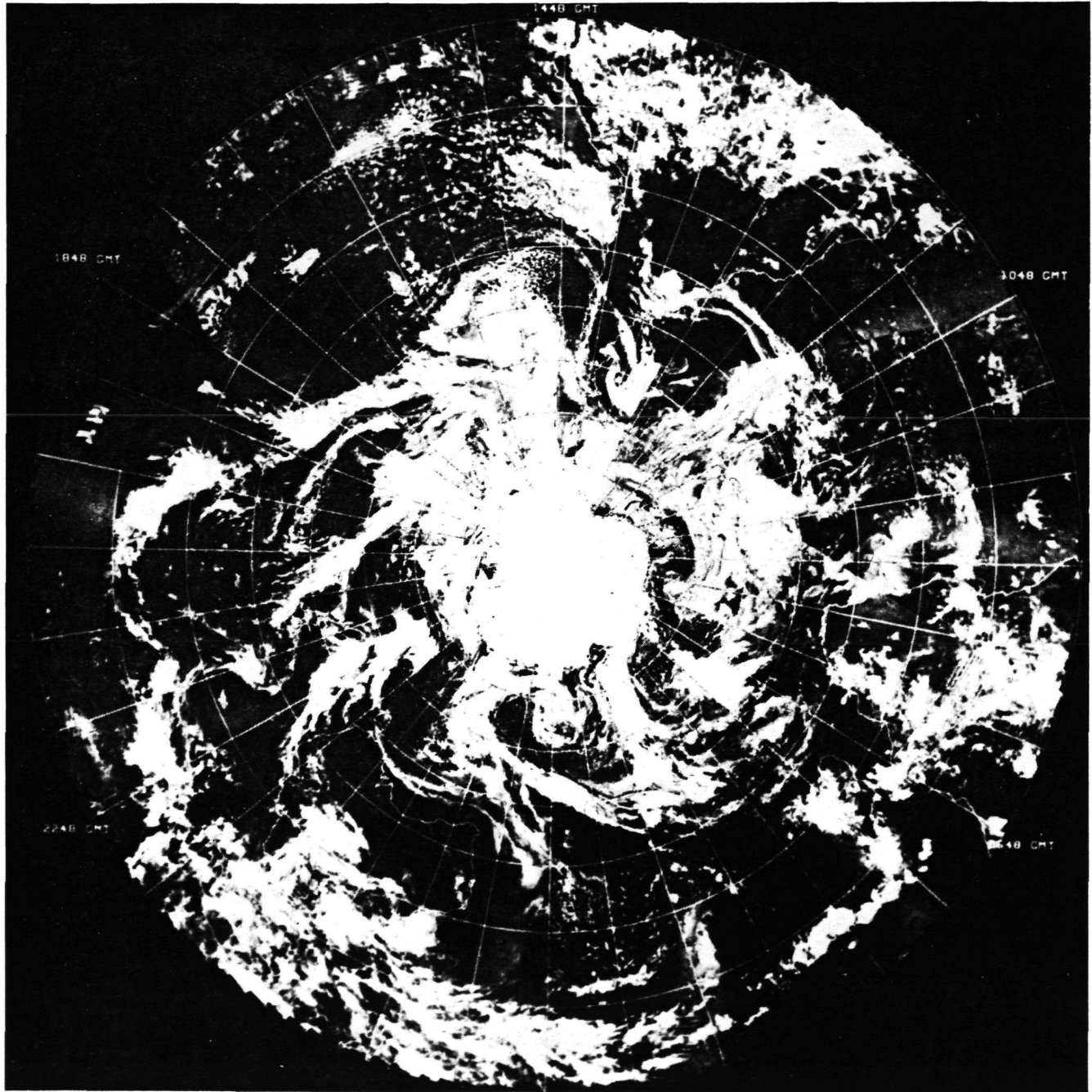

Fig. 4.7: National Oceanic and Atmospheric Administration satellite global photograph 1134/1146. The Earth's southern hemisphere taken 14-15 February 1975. South America is at the top. South Pole and Antarctic ice pack in center.

5. What is the difference between the cloud patterns in the southern hemisphere and the northern hemisphere?

6. Which way does the Earth rotate as seen in Figure 4.7?

7. Why do you think the tail of clouds emanating from the spiral extends in the direction observed?

8. Examine Figure 4.8. Notice the beautifully defined spiral over northeastern Europe and another east of Greenland. Compare it to the diffused spiral off the southeastern coast of South America. Explain why they both look as they do.

9. The band of clouds across the central portion of the picture is called the intertropical convergence zone (ITC). It occurs where maximum heating drives moist air into the upper atmosphere.

a. Look at Figure 4.8. Where should the ITC be located according to the simplified picture?

b. Look at your world map. Locate the equator in Figure 4.8. Is the ITC north, south or directly over the equator?

c. What season of the year is it most likely to be based on your answer to b?

10. Again look at Figure 4.8. What kind of weather would you forecast for the next 24 hours in:

a. Madrid?

ORIGINAL PAGE
BLACK AND WHITE PHOTOGRAPH

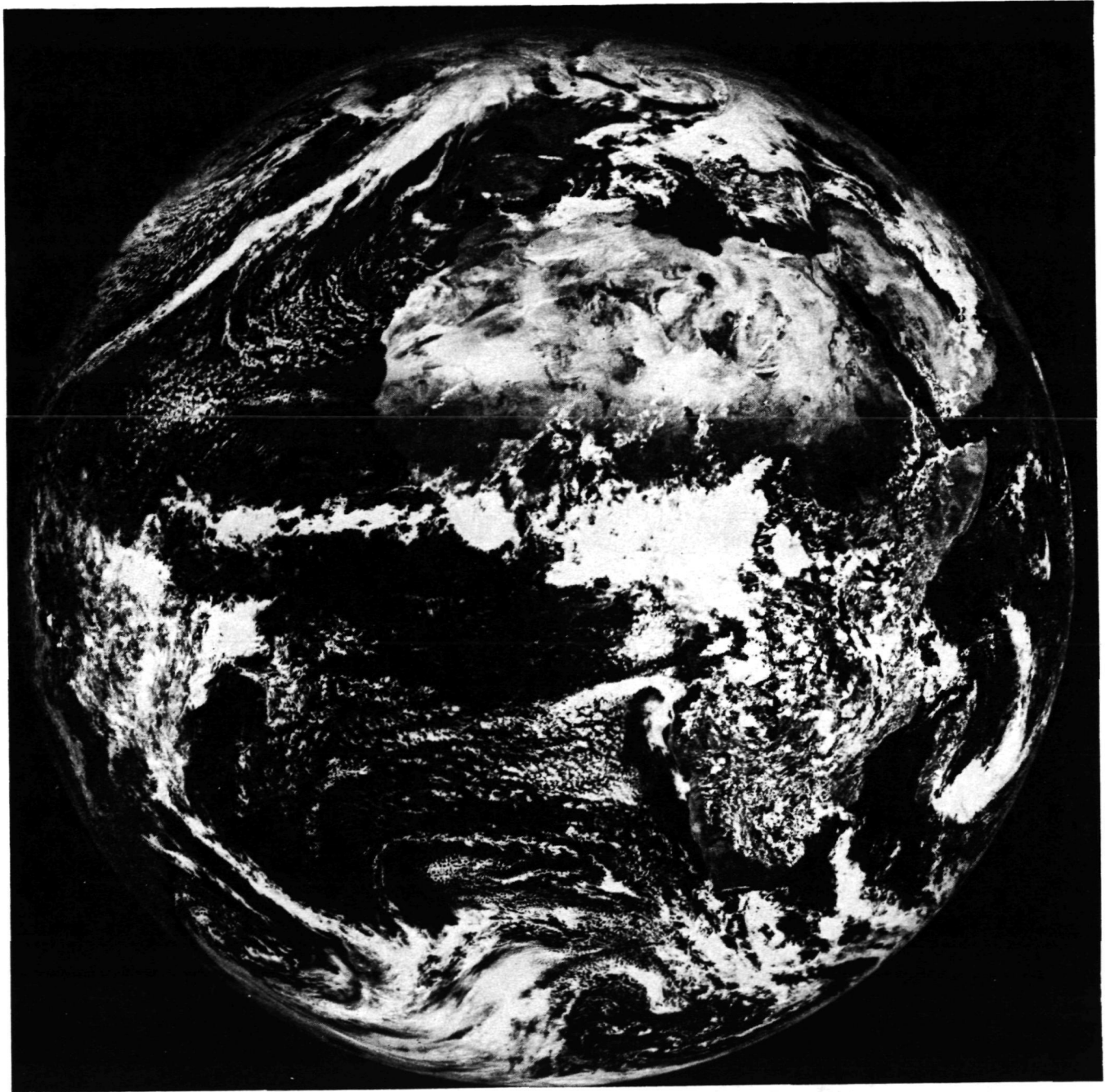

Fig. 4.8: The Earth as seen from the European Meteosat weather satellite. The picture was taken in 1978 at noon, Greenwich Mean Time. The north pole is precisely at the top. Note the extremely clear weather over Spain, Portugal, France, all of northern Africa and the Middle East.

ORIGINAL PAGE
BLACK AND WHITE PHOTOGRAPH

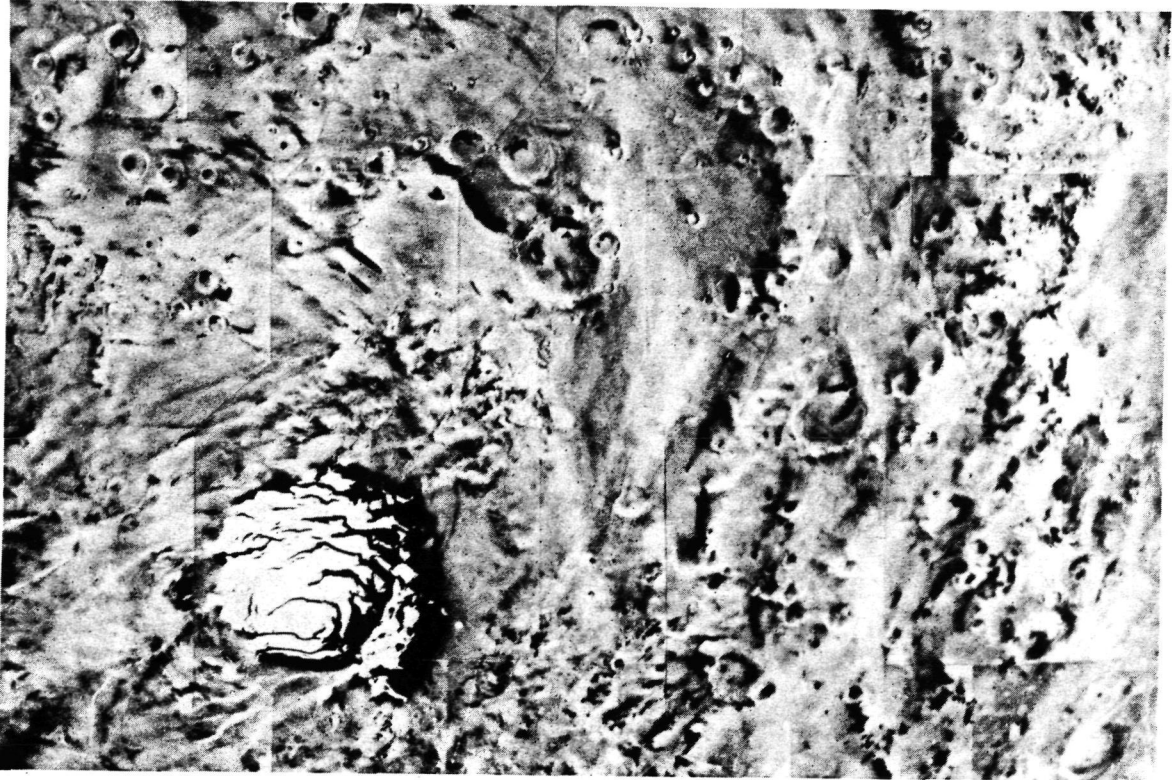

Fig. 4.9: Portion of Viking mosaic 211-5452 showing a region around the south polar cap. The bright polar cap is composed mainly of "dry ice" or frozen carbon dioxide.



Fig. 4.10: Viking Orbiter photo 783A42, showing a water frost cloud pattern over the surface of Mars. North is to the top.

b. Cairo?

c. Cape Town?

d. London?

11. Study Figure 4.9. Pay particular attention to any wind indicators you might see. Mars rotates in the same direction as Earth.

a. What evidence is there that the Coriolis effect is at work here?

b. How can you be sure that this is the southern ice cap?

12. Look at Figure 4.10 taken by a spacecraft over Mars.

a. What do you think this cloud feature is?

b. In what hemisphere is this feature and why?

13. Figure 4.11 was taken by a spacecraft that flew past Jupiter. The Great Red Spot (GRS) appears to be a great storm.

a. In which direction are the winds around the GRS rotating?

b. Is the GRS located in the southern or northern hemisphere?

- c. Is the rotation correct for a Coriolis-induced low pressure storm?
-

ORIGINAL PAGE
BLACK AND WHITE PHOTOGRAPH

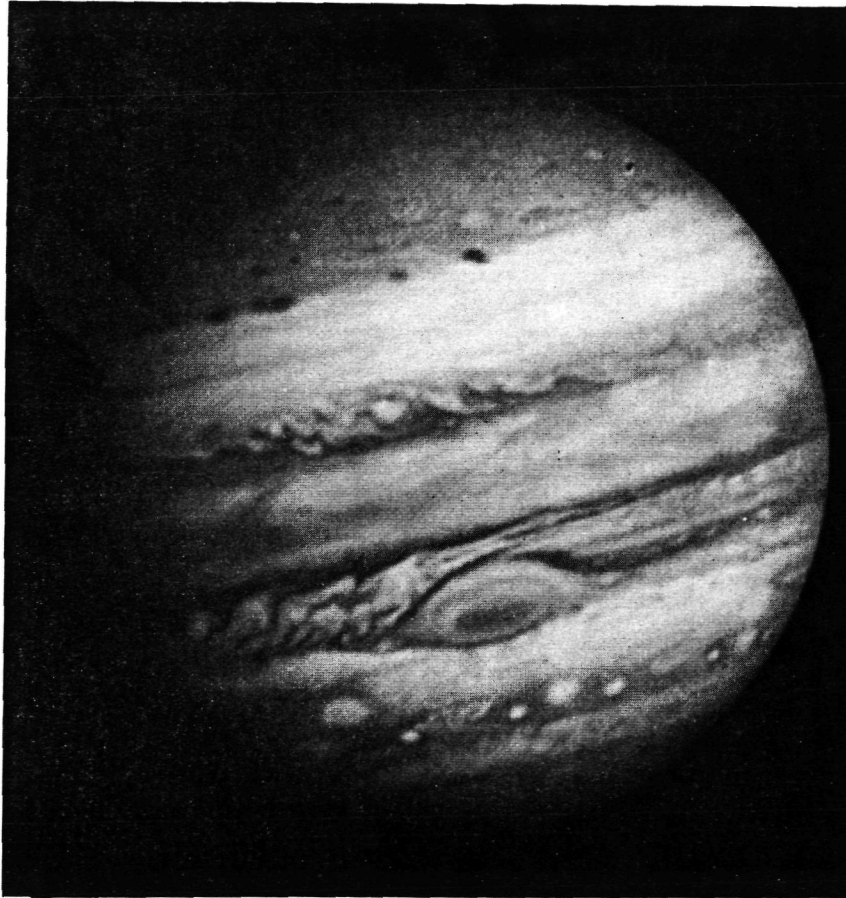

Fig. 4.11: Jupiter. Voyager 1 took this approach picture on January 9, 1979, from 54 million km (34 million miles) out. The GRS is the large vortex just below center. North is at the top.

STORM SYSTEMS

(Instructor's Key)

1. Examine the NOAA satellite photomosaic of the northern hemisphere (Fig. 4.6). The clouds appear to form tightening spirals to the north. Examine in particular the spiral on the 2248 GMT meridian (left and slightly above center). These spirals are low pressure cells or cyclones. Surface winds converging into the low are affected by the Coriolis force (compare with Fig. 4.5).

- a. Which way do the spirals appear to be tightening, clockwise or counterclockwise?

Counterclockwise.

- b. Why?

The Coriolis deflection of winds in the northern hemisphere causes a counterclockwise circulation around a low.

- c. What do you think the long tail of clouds attached to the spiral represents?

A cold front; rain squalls.

- d. What kind of weather is likely to be associated with this cloud pattern?

Showers, perhaps heavy; depending on season, snow, sleet, hail, etc.

2. In which direction does Earth rotate as seen in Figure 4.6?

Counterclockwise.

3. Why do you think weather systems move from west to east? In other words, why does a storm over California end up in Virginia in a few days?

Counterclockwise motion of Earth exerts a frictional drag on the atmosphere "pulling" it along at a slower pace in a counterclockwise direction: west to east.

4. Examine the NOAA satellite photomosaic of the southern hemisphere (Fig. 4.7).

- a. Notice the well-developed spiral of clouds southwest of Australia (off the coast of Antarctica below center). What is this feature?

A low pressure cell; a cyclonic storm.

- b. Which way does the cloud spiral tighten?

Clockwise.

- c. Why?

The opposite Coriolis deflection (to the left) is expected for the southern hemisphere.

5. What is the difference between the cloud patterns in the southern hemisphere and the northern hemisphere?

They are similar in form, but opposite in direction. Also note that patterns are slightly more regular than those in the northern hemisphere because in contrast to the northern hemisphere, land masses do not interfere significantly with the circulation around the southern pole to 45°S latitude.

6. Which way does the Earth rotate as seen in Figure 4.7?

Clockwise.

7. Why do you think the tail of clouds emanating from the spiral extends in the direction observed?

The front and air masses near the cyclonic storm lag behind the motion of the cyclone itself.

8. Examine Figure 4.8. Notice the beautifully defined spiral over northeastern Europe and another east of Greenland. Compare it to the diffused spiral off the southeastern coast of South America. Explain why they both look as they do.

Both are cyclonic storms or low pressure cells. Northern and southern storms spin in opposite directions. The weather in the northern storm is likely to be more violent and organized.

9. The band of clouds across the central portion of the picture is called the intertropical convergence zone (ITC). It occurs where maximum heating drives moist air into the upper atmosphere.

- a. Look at Figure 4.8. Where should the ITC be located according to the simplified picture?

Over the equator.

- b. Look at your world map. Locate the equator in Figure 4.8. Is the ITC north, south or directly over the equator?

North of the equator.

- c. What season of the year is it most likely to be based on your answer to b?

Midsummer since the Sun is directly over those latitudes just north of the equator at that time. Maximum heating occurs at the subsolar point. Midspring is also a reasonable answer.

10. Again look at Figure 4.8. What kind of weather would you forecast for the next 24 hours in:

- a. Madrid?

Increasing cloudiness followed by rain, heavy at times.

b. Cairo?

Continued clear and hot.

c. Cape Town?

Partly cloudy and cold.

d. London?

Continued showers likely, cooling.

11. Study Figure 4.9. Pay particular attention to any wind indicators you might see. Mars rotates in the same direction as Earth.

a. What evidence is there that the Coriolis effect is at work here?

There are several dark wind streaks behind craters north of the polar ice. The streaks trail the craters to the northwest. Cool, northward moving air was deflected to the west (left).

b. How can you be sure that this is the southern ice cap?

The left deflection of winds indicate the picture was taken in the southern hemisphere.

12. Look at Figure 4.10 taken by a spacecraft over Mars.

a. What do you think this cloud feature is?

A low pressure center; a cyclonic storm.

b. In what hemisphere is this feature and why?

Northern hemisphere; spirals are tightening counterclockwise around the low.

13. Figure 4.11 was taken by a spacecraft that flew past Jupiter and is now on its way past Saturn and out of the solar system. The Great Red Spot (GRS) appears to be a great storm.

a. In which direction are the winds around the GRS rotating?

Counterclockwise.

b. Is the GRS located in the southern or northern hemisphere?

Southern.

- c. Is the rotation correct for a Coriolis-induced low pressure storm?

No. the rotation of the GRS in Fig. 4.11 appears to be counterclockwise. Close observation shows that gases are piling up into turbulent eddies on the western (left) side of the GRS and are smoothly flowing around the system on the eastern side.

The GRS is a storm of unknown origin. Although Voyager was able to measure its rotation rate, it could not conclusively prove if clouds were rising out of the center or diverging at the top. The rotation of the GRS is evidently a result of bands of wind moving in opposite directions north and south of it. This is called shearing. It is equivalent to rolling a ball between the palms of your hands as you move them in opposite directions. The GRS is **not** the result of the Coriolis effect on Jupiter.

UNIT FIVE

THE GEOLOGICAL MAPPING OF OTHER PLANETS

Few things are as important to explorers as good maps. The same is true for planetary scientists who must do their exploring by looking at spacecraft pictures. The importance of surface maps to the scientific study of a planet cannot be overestimated. The geologic history of a planetary surface can be read from specially drawn maps. Measurements of the sizes of planetary features can be derived from precision mapping. An appreciation for the scope and mechanisms of external (e.g. cratering) and internal (e.g. volcanic) processes comes from mapping.

There are many types of maps that can be drawn to describe a planet's surface. The simplest is a reproduction of the visible surface features within a chosen area at an appropriate scale on an appropriate projection. Photographs or shaded relief maps can serve this purpose. Topographic contour maps superimpose elevation data on the base maps. Geologic maps identify distinct surface materials on the base map and place the units in a time sequence. In this unit the principles of geologic mapping are developed.

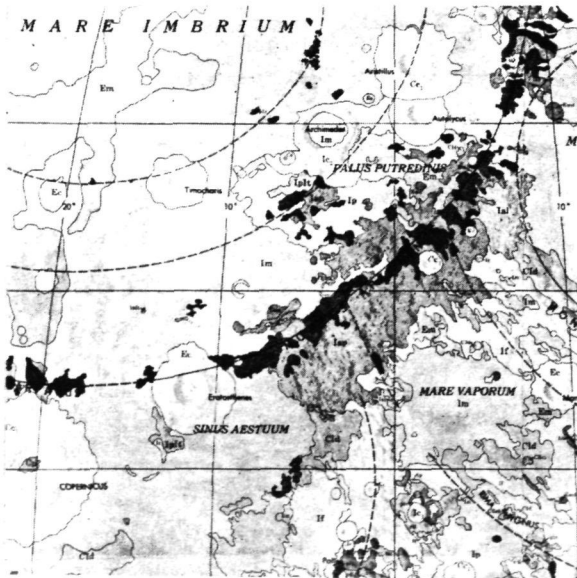

Fig. 5.1: The geology of the Lunar Apennines. This is a small section of the 1971 geologic map of the near side of the Moon by Wilhelms and McCauley (U.S. Geological Survey Map I-703). The map is a combination of observations and interpretations of lunar surface materials displayed in such a way as to make sense out of the seemingly complex jumble of features. Materials with similar characteristics are enclosed by boundary lines called contacts. Each material unit is identified by a two-letter symbol that specifies not only its type, but also its relative age. The work is based partly on spacecraft and partly on telescopic photography.

ORIGINAL PAGE
BLACK AND WHITE PHOTOGRAPH

Name _____

Class _____ Date _____

PHOTOGEOLOGIC MAPPING OF THE MOON: THE PROVINCES

OBJECTIVE

To recognize how careful observations of a planet can be turned into geologic maps that yield valuable information.

MATERIALS

None required.

PROCEDURE AND QUESTIONS

A geologic map is a tool used to display geologic information in a concise and descriptive way. Such a map allows a geologist to represent his observations in a form that can be understood by others. It summarizes observations made at different geographic localities in a unified form. A geologist uses a geologic map as a physicist uses a graph. To understand a great many geologic observations in a comprehensive way without a map would be difficult.

The making of geologic maps involves classifying surface and near-surface rocks in different units according to their type and age. On Earth this involves a combination of field work, laboratory studies, and analyses of aerial photographs. In planetary geology, geologic mapping must be done remotely—mostly by interpretation of spacecraft photographs (field work is rather costly and not always practical!). Map units are identified on photographs by distinct, observable characteristics, such as color, roughness, resistance to erosion, light-scattering ability, or other physical or chemical properties. It is assumed that similar rock types or rock forming materials will have similar characteristics on the photographs.

On the Moon and Mercury most of the effort in making geologic maps involves distinguishing various units created by impact craters. Volcanism also created some units. The same is true on all other inner planets. The Earth and Mars also have atmospheres which contribute new processes. In general all planetary surfaces have been subjected to volcanism, impact cratering, gradation (e.g. erosion) and tectonism (e.g. earthquakes). The relative importance of each is responsible for the different "faces" of the planets we see.

This brief exercise shows that the surface of the Moon is not the same everywhere. The Moon can be roughly divided into two provinces or terrains. Each of the two terrains is made up of many different units. Small areas have distinctive characteristics that, when observed on high resolution photographs or on the ground, are seen to be separate rock units, or *formations*. But the first step in planetary exploration is always to simplify the general appearance of a planet, to look at "the big picture".

1. Examine Figure 5.2, an observatory photograph of the near side of the Moon.
 - a. Is the surface of the Moon homogeneous, that is, is it composed of material that appears to be the same everywhere?

- b. Why or why not?



Fig. 5.2: The waning gibbous Moon. Notice that near the terminator the detail seems to increase. In fact, the higher the sun climbs in the lunar sky, the brighter the surface appears because of the high reflectivity of the cratered terrain. The bright ray patterns surrounding some of the prominent impact craters become most obvious under nearly overhead illumination. Photo from the personal collection of Ewen A. Whitaker, University of Arizona.

2. What is most noticeable about the lunar surface?

3. Determine for yourself that the Moon can be divided into two main terrain types or provinces, (for example, continents and oceans on Earth). List as many characteristics of each terrain as you can. Study Figure 5.2.

TERRAIN "A"

TERRAIN "B"

4. What characteristics of the lunar surface (that can be distinguished on the photographs) did you use to distinguish the two terrains?

PHOTOGEOLOGIC MAPPING OF THE MOON: THE PROVINCES

(Instructor's Key)

1. Examine Figure 5.2, an observatory photograph of the near side of the Moon.
 - a. Is the surface of the Moon homogeneous, that is, is it composed of material that appears to be the same everywhere?

No.

- b. Why or why not?

At this scale, the lunar surface appears heterogeneous.

2. What is most noticeable about the lunar surface?

The most obvious characteristic of the lunar surface is the presence of craters, from extremely large degraded circular structures (basins) to bowl-shaped depressions at the limit of resolution.

3. Determine for yourself that the Moon can be divided into two main terrain types or provinces, (for example, continents and oceans on Earth). List as many characteristics of each terrain as you can. Study Figure 5.2.

TERRAIN "A"

The Lunar Maria (dark plains)

1. *dark (low albedo)*
2. *smooth (low relief)*
3. *sparsely cratered*
4. *topographically low areas*

TERRAIN "B"

The Lunar Terra (bright highlands)

1. *light (high albedo)*
2. *rough (high relief)*
3. *heavily cratered*
4. *topographically high areas*

4. What characteristics of the lunar surface (that can be distinguished on the photographs) did you use to distinguish the two terrains?

Albedo (reflectivity), topographic relief, density of craters.

Name

Class Date

PHOTOGEOLOGIC MAPPING OF THE MOON: STRATIGRAPHY

OBJECTIVES

To demonstrate how stratigraphic units can be recognized on another planet and how they can be ordered in time.

MATERIALS

1. 8½" x 11" clear film acetate overlays
2. Grease pencils

PROCEDURE AND QUESTIONS

Nicholas Steno, a seventeenth century Danish physician, is credited with first stating the simple but powerful geological **Principle of Superposition**. He wrote that ". . . at the time when the lowest stratum was being formed, none of the upper strata existed," or in its modern restatement, the youngest strata are found at the top of a vertical sequence, the oldest at the bottom. Although this principle seems obvious, erosion and tectonism (movement of the crust) sometimes makes it difficult to sort out the correct sequence in which rocks were stratified on Earth. On other planets, however, this principle is translated into relative age determinations through observations such as onlap, embayment relationships, transection, crater density, and crater degradation. Look at the idealized geologic map in Figure 5.3. Three rock units have been mapped based on their identifiable and distinctive surface characteristics (surface morphology, albedo, etc.). How are their relative ages determined? Unit A embays several of the large craters and topographic prominences characteristic of Unit C. This strongly suggests that Unit A onlaps onto, or is superposed onto, Unit C. Therefore, Unit A appears relatively younger than Unit C. Supporting evidence for this conclusion can be found in terms of impact crater density and crater degradation. Impact craters are much more abundant on Unit C, and the majority of craters found there are more degraded than those found on Unit A. Since more impact craters accumulate on a surface with time, this supports an older age for Unit C. What about Unit B? This unit appears superposed on Unit A, and portions of the unit even appear to onlap onto Unit C. Thus, from these relationships, it can be established that B is the relatively youngest unit, A is the next oldest, and C is the oldest unit. What about the two graben or faults in the area? Fault 1 cuts, or transects Unit C (and is thus younger) but does not cut and is embayed by Unit A (and is thus older). Fault 2 transects Units C, A and B, and is thus the youngest mapped feature in the area. From the series of concepts rooted in the Principle of Superposition we can arrive at the following relative age sequence (stratigraphic column) and history for the region (oldest listed at base):

	GEOLOGIC ROCK UNITS	FAULTS
Youngest	Unit B emplacement Unit A emplacement	Fault 2
Oldest	Unit C emplacement	Fault 1

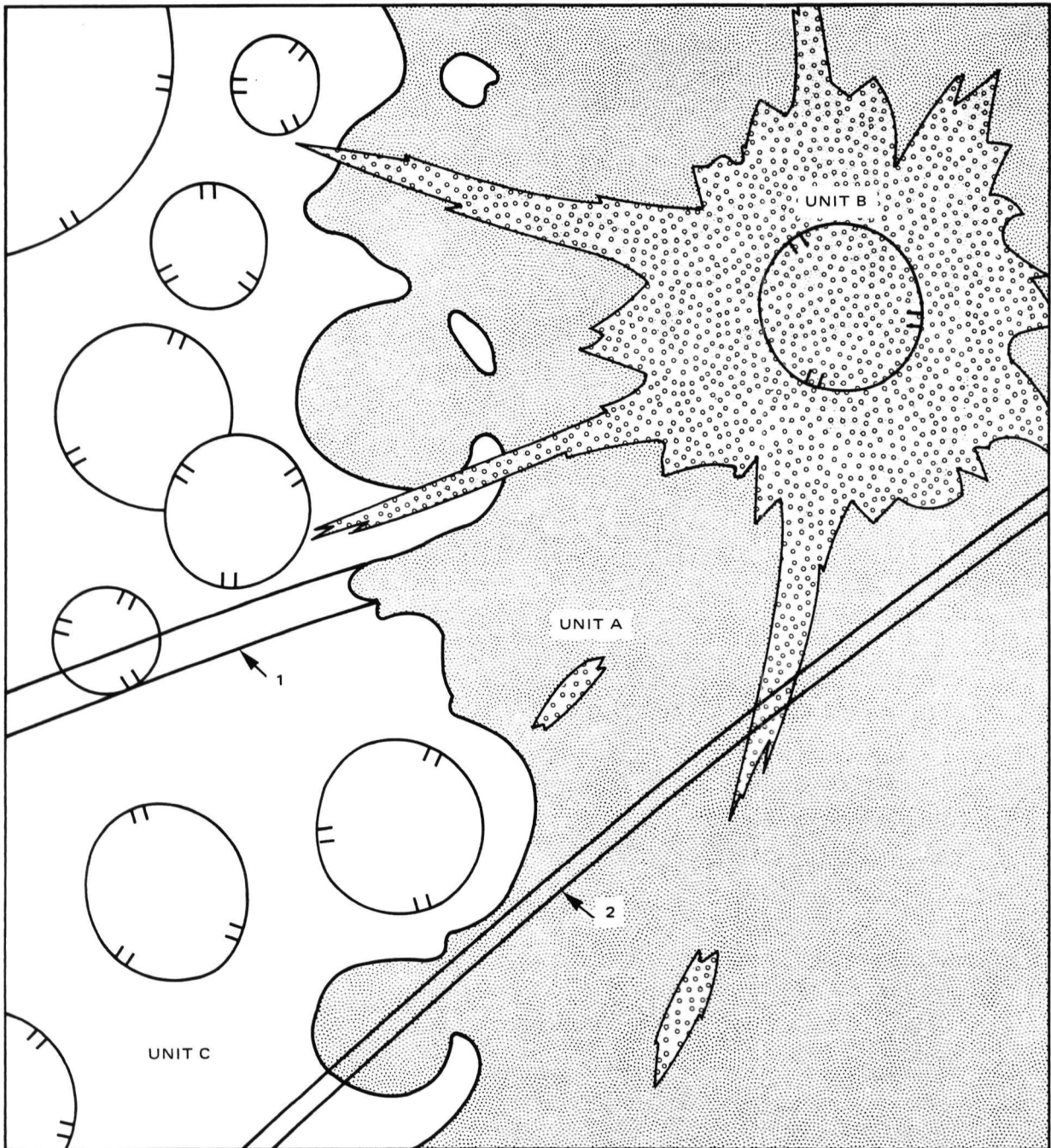

	GEOLOGIC ROCK UNITS	FAULTS
Youngest	Unit B emplacement	Fault 2
	Unit A emplacement	
Oldest	Unit C emplacement	Fault 1

Fig. 5.3: An idealized portion of the lunar surface. Each unit is meant to display the observable physical characteristics in general of real lunar surface features.

Figure 5.4 is a picture of the Apollo 15 lunar landing site taken from the orbiting command and service module. The picture is also a detailed look at the boundary between the two terrain types you studied in the previous activity.

1. Place the clear film acetate over Figure 5.4. With the grease pencil trace the outline separating the two terrain types.
2. Remove the acetate and list the characteristics you used to distinguish the terrains; that is, list the features of each terrain.

TERRAIN A

TERRAIN B

3. What do you think is the age relationship between the two terrains? Give your reasons.

.....

4. Is there any discrepancy between your answer to Question 3 and the list of characteristics you made in the previous activity, Question 3? How might any problems be resolved?

.....

.....

5. What is the possible origin of the sinuous trough (Rima Hadley) winding from N-6 up to its bifurcation at C-5?

.....

.....

6. Replace the acetate and trace Rima Hadley.

7. Look carefully at the prominent crater at K-7 (Hadley crater). What is its age relative to Rima Hadley? How do you know this? What about relative to the terrain in which it is found? Why? Relative to the other terrain? Why?

.....

.....

.....

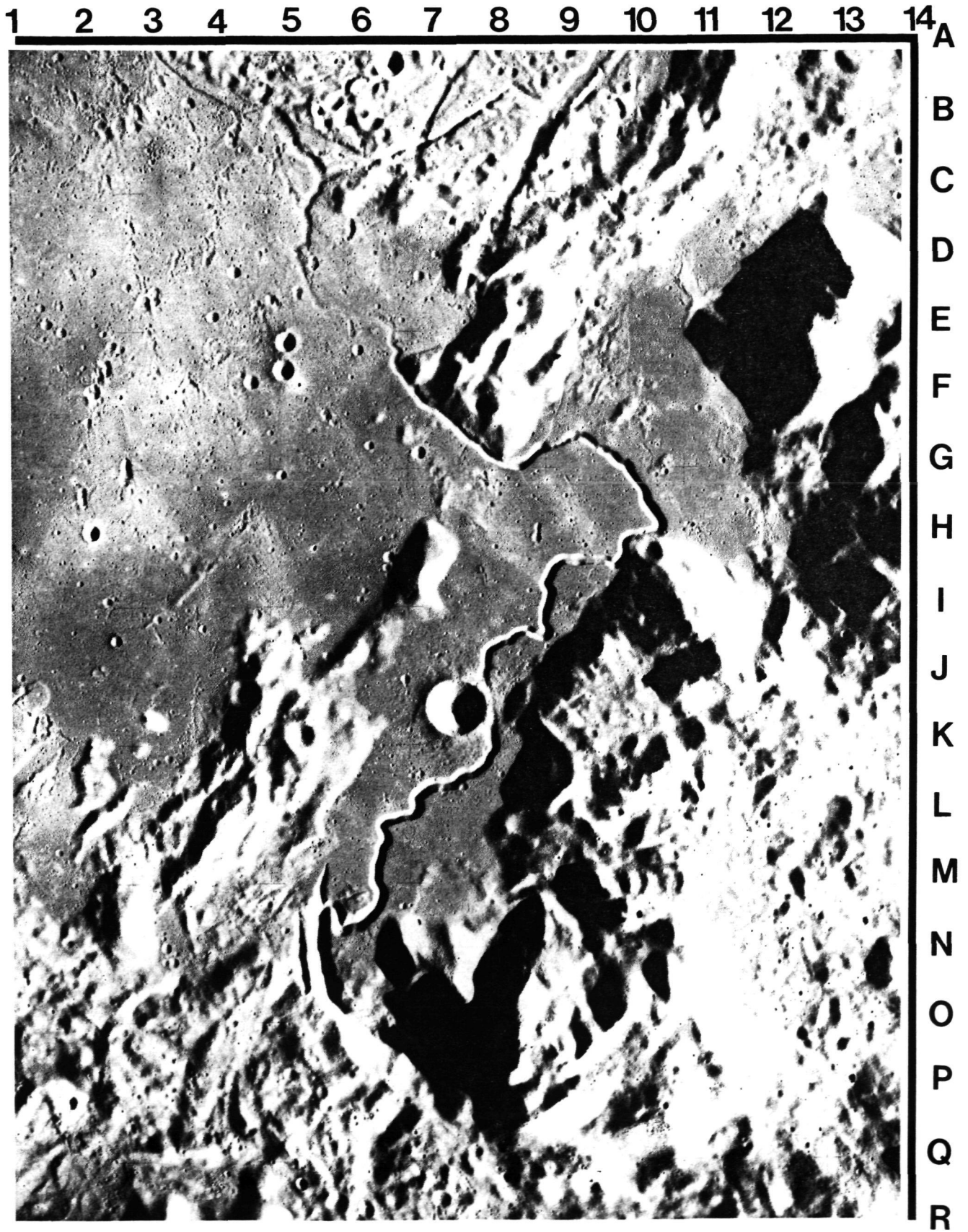

Fig. 5.4: Apollo metric mapping photograph AS15-0585. The picture was taken over the Apollo 15 landing site at H-11.

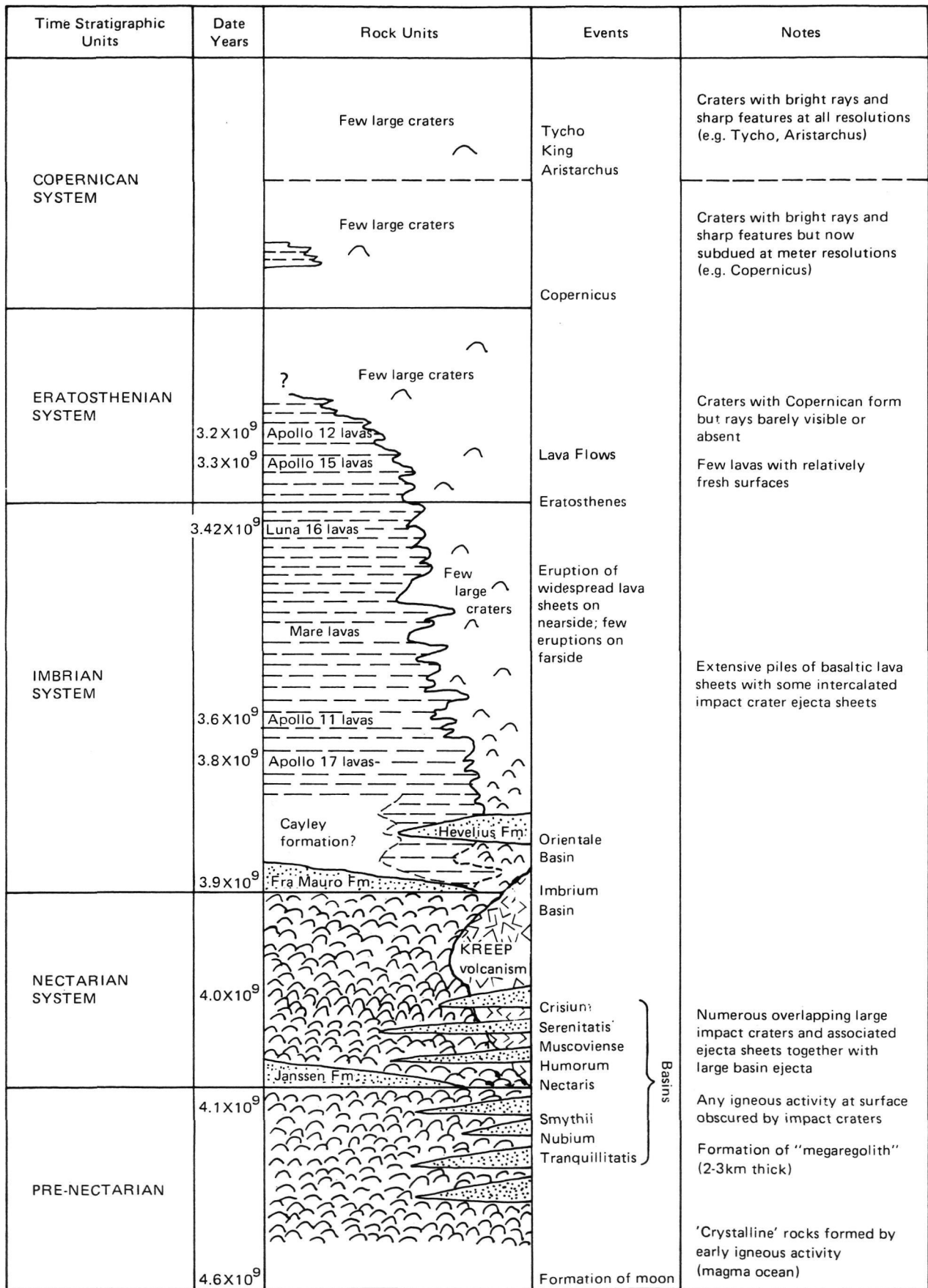

Fig. 5.5: The Lunar Geologic Time Scale.

8. Look at the crater located at K-5. How is it different from Hadley crater (K-7)? What is K-5's age relative to Hadley crater? How can you be sure?

.....

.....

9. Replace the acetate and outline all craters that have characteristics in common with Hadley crater.

10. Study the region around F-3. Is there any evidence for another process that has left its imprint on the lunar surface? What is the age of this process relative to the terrain in which it is found?

.....

.....

.....

.....

11. There is a very tiny crater located almost exactly at F-5, immediately southeast of two large craters lined up in a north-south direction. What do you notice about the surface immediately surrounding the small crater? What does that tell you about its age? Is this the only tiny crater with this characteristic? (hint: look to the right of F-3)

.....

.....

.....

12. Replace the acetate and outline the areas like those you discovered in Questions 9 and 10.

13. Place all of the geologic units and special features you have just studied in the correct age sequence in the chart below. When you think you have the correct age sequence, consult the simplified lunar geologic time scale (Fig. 5.5). Then fill the appropriate time stratigraphic unit beside each feature.

	GEOLOGIC ROCK UNITS	OTHER FEATURES	TIME UNITS
youngest			
oldest			

PHOTOGEOLOGIC MAPPING OF THE MOON: STRATIGRAPHY

(Instructor's Key)

1. Place the clear film acetate over Figure 5.4. With the grease pencil trace the outline separating the two terrain types.
2. Remove the acetate and list the characteristics you used to distinguish the terrains; that is, list the features of each terrain.

TERRAIN A

mare terrain

1. *dark*
2. *flat*
3. *cratered*
4. *troughs*
5. *crisp features*

TERRAIN B

highland terrain

1. *mountainous*
2. *bright*
3. *cratered*
4. *eroded features*

3. What do you think is the age relationship between the two terrains? Give your reasons.

The highland terrain is older because the mare terrain embays it.

4. Is there any discrepancy between your answer to Question 3 and the list of characteristics you made in the previous activity, Question 3? How might any problems be resolved?

The highland terrain should be more heavily cratered. It does not appear to be, but in fact the heavy cratering history has eroded crisp features and obliterated older craters.

5. What is the possible origin of the sinuous trough (Rima Hadley) winding from N-6 up to its bifurcation at C-5?

Answers will vary, but most should suggest fluid flow, like water. Water was not found on the Moon. The fluid was basaltic lava flows.

6. Replace the acetate and trace Rima Hadley.

7. Look carefully at the prominent crater at K-7 (Hadley crater). What is its age relative to Rima Hadley? How do you know this? What about relative to the terrain in which it is found? Why? Relative to the other terrain? Why?

Hadley crater is younger than Rima Hadley because it obliterates part of it. It is younger than the terrain in which it is found because of superposition and younger than any feature older than the mare terrain.

8. Look at the crater located at K-5. How is it different from Hadley crater (K-7)? What is K-5's age relative to Hadley crater? How can you be sure?

K-5 is more degraded (eroded) and is located in the highland, mountainous terrain. Because it is located in a different unit and there are no obvious materials common to both, it is not possible to tell the relative age.

9. Replace the acetate and outline all craters that have characteristics in common with Hadley crater.

10. Study the region around F-3. Is there any evidence for another process that has left its imprint on the lunar surface? What is the age of this process relative to the terrain in which it is found?

There are "chicken track" or herringbone-shaped gouges on the surface surrounded by bright material. They appear to have been caused by a process other than fluid flow or initial (primary) impact. In fact, they are secondary impact structures carved by low angle, ballistically emplaced debris from a distant primary impact. The bright material, like rays, is locally disturbed material. The secondaries are thus younger than anything on the photo.

11. There is a very tiny crater located almost exactly at F-5, immediately southeast of two large craters lined up in a north-south direction. What do you notice about the surface immediately surrounding the small crater? What does that tell you about its age? Is this the only tiny crater with this characteristic? (hint: look to the right of F-3)

This tiny crater also has a small bright ray pattern. That together with its crisp appearance suggests that it is as young as the herringbone secondaries. There are other examples elsewhere.

12. Replace the acetate and outline the areas like those you discovered in Questions 9 and 10.

13. Place all of the geologic units and special features you have just studied in the correct age sequence in the chart below. When you think you have the correct age sequence, consult the simplified lunar geologic time scale (Fig. 5.5). Then fill the appropriate time stratigraphic unit beside each feature.

	GEOLOGIC ROCK UNITS	OTHER FEATURES	TIME UNITS
youngest		<i>tiny rayed craters</i> <i>herringbone secondaries</i>	{ <i>Copernican</i>
	<i>mare</i>	<i>Hadley crater</i> <i>Rima Hadley</i>	{ <i>Eratosthenian</i>
oldest	<i>terra</i>	<i>old craters</i>	{ <i>Imbrian</i>

Name _____

Class _____ Date _____

THE PLANETS IN STEREO

OBJECTIVES

To appreciate the importance of studying geologic features as three dimensional bodies.

MATERIALS

Classroom pocket stereoscope

PROCEDURE AND QUESTIONS

Geologists are concerned with rock formations as three dimensional bodies. When geologic maps are drawn, they are never complete until a cross-section describing the vertical relationships of formations is drawn. Drawing cross-sections of planetary surfaces is not always a simple matter. Natural incisions in the surface, such as canyons or craters, are helpful in visualizing rock layering to a modest depth. Accurate topographic measurements necessary for an understanding of planetary stratigraphy can be obtained from stereoscopic pictures.

Special tools can be used with stereoscopic aerial pictures to draw topographic contour maps. Elevations can then be calculated for surface features. Today computers are used to draw complete topographic maps from a stereo pair of photos. But you can discover some simple geologic and geometric relationships among surface materials from careful study of stereograms.

People with normal vision in both eyes have depth perception because they have stereo vision. We all have a pair of eyes with lenses that are separated by about 65 mm. Under normal circumstances the brain receives two images of the same target, each from a slightly different angle. The brain then interprets the scene as one, but with depth. We use the same principle to make a stereogram.

Figure 5.6 is a stereogram made from Figure 5.4 and its stereo mate. Stereo pairs are made by taking two consecutive photographs of the same target from slightly different angles. A spacecraft can automatically do this as it travels in its orbit. The special metric mapping cameras on board the Apollo vehicles took sequential pictures that overlapped by 78 percent. That is similar to the overlap that our two eyes provide for the same scene. To reconstruct the stereo, each half of a stereogram must be seen by a separate eye. A pocket stereoscope allows you to do this.

1. Examine Figure 5.6 using the pocket stereoscope. Study the contact (boundary where two different types of materials meet) between the hills and low dark plains. Describe the contact and draw some conclusions about the age relationship between the hills and plains.

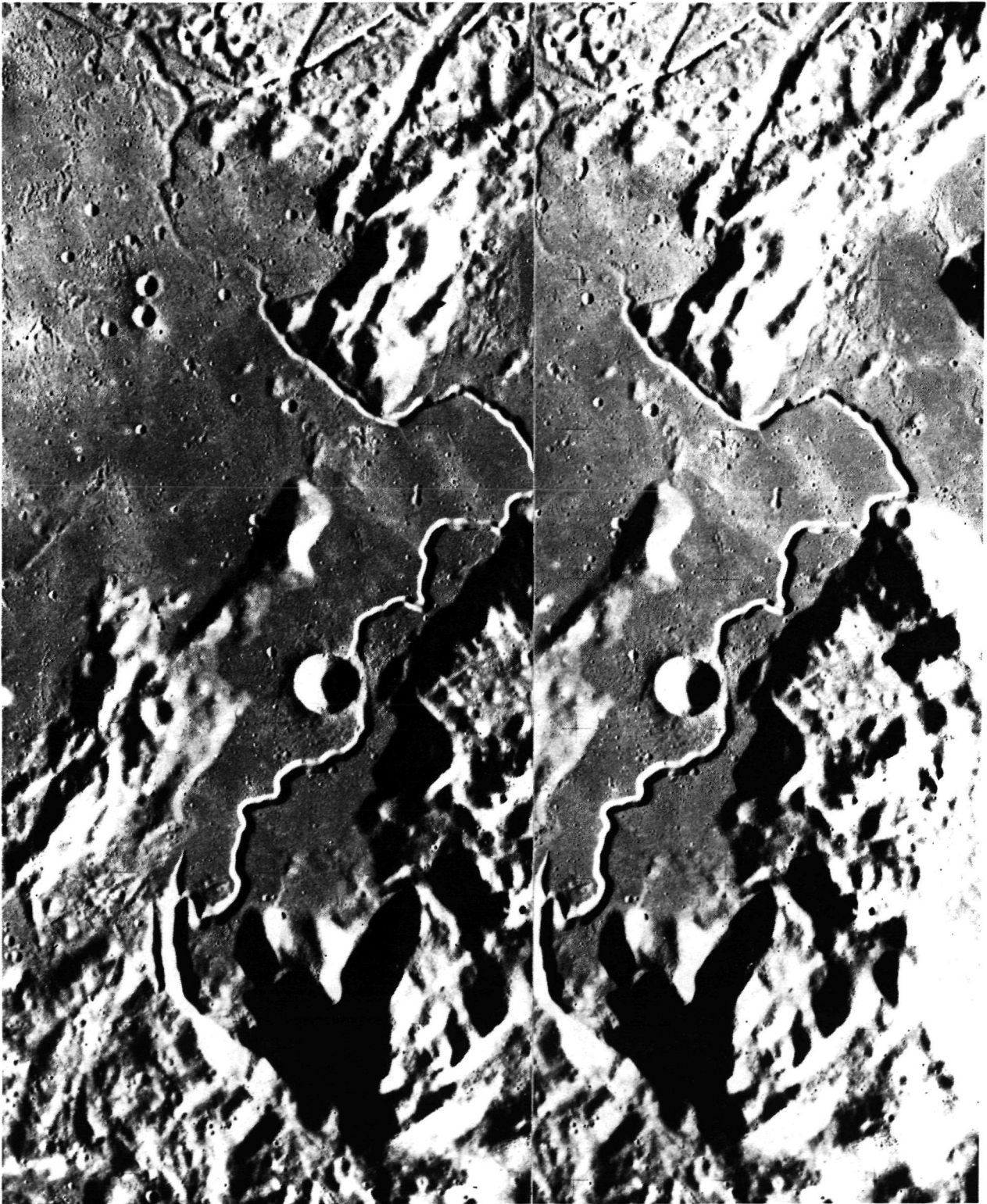

Fig. 5.6: Stereogram of the Apollo 15 landing site area. Left half is a portion of AS15-0586, right half, AS15-0585. Spacecraft motion is from right to left parallel to the bottom edges of the pictures. Rima Hadley, the sinuous trough, is 300 m deep. The prominent central crater, Hadley, is 5.7 km in diameter. Corresponding features in the left and right halves are 60 mm apart. North is to the top. The spacecraft was 103 km above the ground.

ORIGINAL PAGE
BLACK AND WHITE PHOTOGRAPH

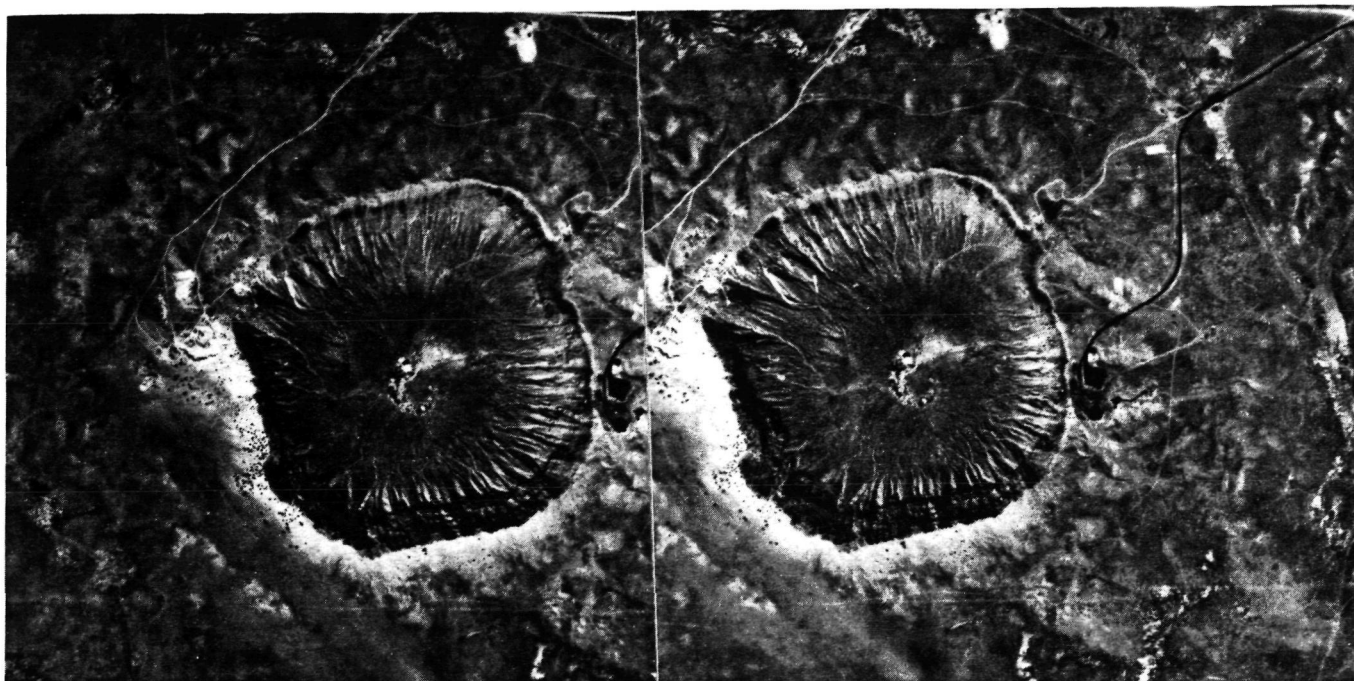

Fig. 5.7: Stereogram of Meteor Crater, Arizona. The left and right frames were taken by a U.S. government aircraft flying from north to south over the crater. North is printed to the right so that aircraft motion is from right to left. The dark square on the north rim of the crater is the parking lot for the main Visitors Center located immediately east (below). An old dirt access road is seen approaching the south rim. The features on the floor of the crater are the remains of a turn-of-the-century drilling outpost that was built to recover a suspected deposit of nickel and iron from the meteorite. None was ever found. We know why today: the meteorite never survived the impact. Total depth of the crater is 120 m.

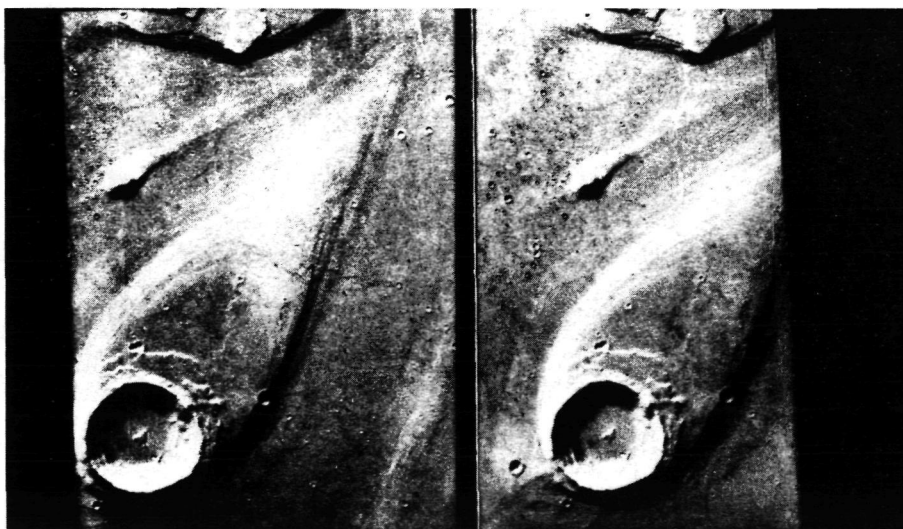

Fig. 5.8: A specially produced stereogram of the surface of Mars. Many stereo pairs of Mars were constructed by the computer facilities at the Jet Propulsion Laboratory in Pasadena, California. This particular product is JPL 77/08/16/221518. It was made by taking orthographic projections of pictures from separate orbits of the Viking spacecraft (left picture VO 75 4A52, right picture VO 75 4A93), scaling each to match the other, and turning them so that apparent spacecraft motion is from left to right. The prominent circular feature at the bottom is 7 km in diameter. North is in the direction of the teardrop point. The picture is 800 km east of the Viking Lander 1 touchdown site.

ORIGINAL PAGE
BLACK AND WHITE PHOTOGRAPH

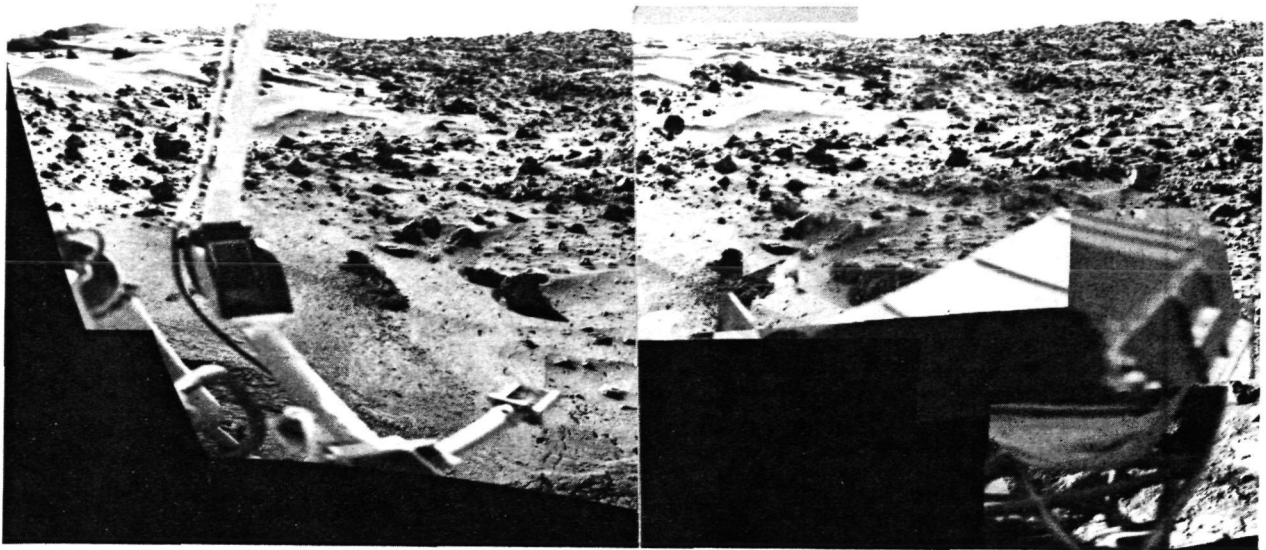

Fig. 5.9: The surface of Mars in stereo. The Viking Lander spacecraft had the capability of taking stereo pictures at the landing site. Since the Lander could not physically move on the surface, it was equipped with two cameras. The cameras were mounted on the top deck 80 cm apart. That is more than 10 times the average 65 mm baseline between our eyes. Therefore, Viking has a considerably enhanced "depth perception". The cameras did not operate like our eyes or conventional film or television cameras. Therefore, special computer generated projections were required to reproduce this stereo pair. The left picture is JPL 78/10/19/171012, the right is JPL 78/10/19/175118. The distance to the rocky crags on the horizon is about 4 km. Rocks in the near foreground are all a few tens of centimeters across.

2. What evidence is there that the Hadley crater was formed by meteorite impact into the dark plains, rather than the plains having flowed around an old pre-existing crater?

.....

3. Describe the age relationship between Hadley crater and Rima Hadley and give your reasons.

.....

.....

4. Study Figure 5.7 in stereo. Describe the rim and explain why its appearance is consistent with an impact crater.

.....

5. What do the dark dots on the rim appear to be?

.....

6. Describe the texture on the interior walls of the crater. What are likely to be the reasons for the texture?

.....

7. Look at Figure 5.8 in stereo. What is the large round feature at the bottom of the picture? Speculate about its origin.

.....

8. What is the relationship between the teardrop-shaped material and the circular structure? Between the teardrop-shaped material and the outer material?

.....

.....

9. Propose an origin for this interesting feature. What importance does the circular feature have to the teardrop-shaped material?

.....

.....

10. Look at Figure 5.9 in stereo. What evidence is there for aeolian (wind) activity at the lander site?

.....

.....

THE PLANETS IN STEREO

(Instructor's Key)

1. Examine Figure 5.6 using the pocket stereoscope. Study the contact (boundary where two different types of materials meet) between the hills and low dark plains. Describe the contact and draw some conclusions about the age relationship between the hills and plains.

The contact is very sharp and abrupt. It appears that the plains lap up and around the hills. The strong suggestion is that the plains once were material that flowed around the hills.

2. What evidence is there that the Hadley crater was formed by meteorite impact into the dark plains, rather than the plains having flowed around an old pre-existing crater?

The rim is raised and slopes continuously upward from the plains.

3. Describe the age relationship between Hadley crater and Rima Hadley and give your reasons.

Hadley's rim appears to cover part of Rima Hadley on the east. The crater is thus younger by superposition.

4. Study Figure 5.7 in stereo. Describe the rim and explain why its appearance is consistent with an impact crater.

The rim is raised, typical of impact craters.

5. What do the dark dots on the rim appear to be?

Large boulders.

6. Describe the texture on the interior walls of the crater. What are likely to be the reasons for the texture?

Gullies due to erosion, wall failure, faulting, etc.

7. Look at Figure 5.8 in stereo. What is the large round feature at the bottom of the picture? Speculate about its origin.

An impact crater; raised rim, central peak, and terraced walls.

8. What is the relationship between the teardrop-shaped material and the circular structure? Between the teardrop-shaped material and the outer material?

The teardrop-shaped material appears to be a plateau or island on a plain. The crater is part of that island. In fact, the island formed as a result of the crater. See next question.

9. Propose an origin for this interesting feature. What importance does the circular feature have to the teardrop-shaped material?

This may be an island in a dry river bed. The crater acted as a barrier to the flow forming a streamlined area behind it protected from erosion.

10. Look at Figure 5.9 in stereo. What evidence is there for aeolian (wind) activity at the lander site?

There appear to be dunes to the left and patches of the same material deposited in the center. Some of the rocks could be ventifacts (carved by wind action).

Name _____

Class _____ Date _____

LANDFORM MAPPING: MOON, MERCURY AND MARS

OBJECTIVES

1. Using an Earth-based lunar photograph, you will describe and outline the following major geologic landforms: mare, highlands (terra) and major craters.
2. Through examination of full globe photographs, you will compare major landforms on the Moon, Mercury and Mars.
3. Through comparison of full planet photographs and the table of characteristics of the planets (endpapers), you will describe:
 - a. The major differences in physical properties for the three planets.
 - b. How observed differences in physical properties could influence the observed landforms.

MATERIALS

1. Grease pencil
2. Compass
3. Table of characteristics of the planets (endpapers)

PROCEDURE AND QUESTIONS

1. Examine Figure 5.10. Using the grease pencil, mark the boundaries of the different landforms on the Moon. Describe the characteristics of each landform which you marked.

2. Which landform features, the light-colored highlands or the flat, dark maria, appears to be the most heavily cratered?

3. Examine Figure 5.11. What landforms do the Moon and Mercury have in common?

ORIGINAL PAGE
BLACK AND WHITE PHOTOGRAPH



Fig. 5.10: Photograph of the waxing gibbous Moon, courtesy of Ewen A. Whitney, University of Arizona. The north pole is at the top. Look up the diameter of the Moon (see table on the endpapers).

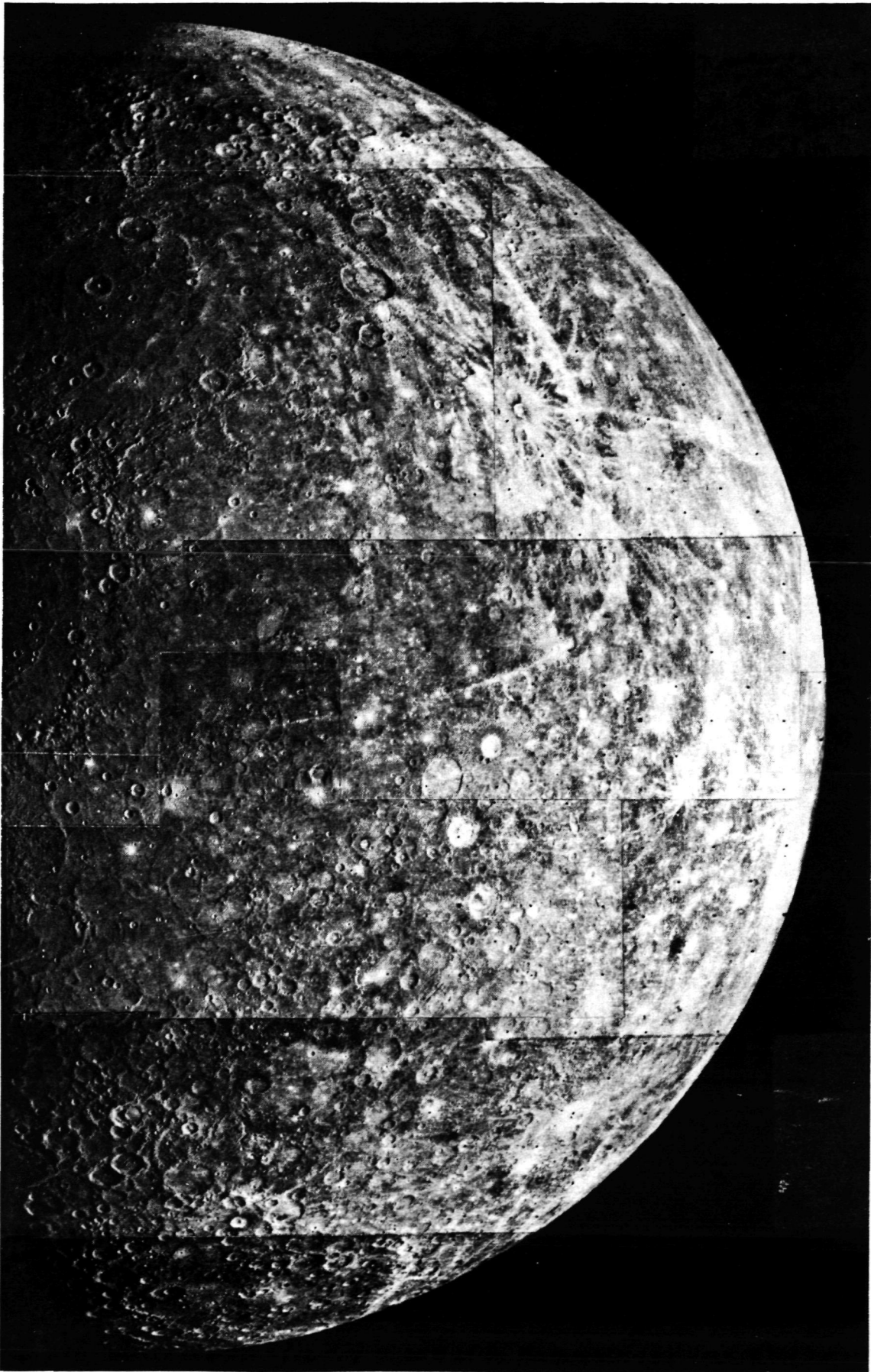

Fig. 5.11: Mariner 10 mosaic of Mercury, NASA P-14580. North is to the top. Look up the diameter of Mercury (see table on the endpapers).

ORIGINAL PAGE
BLACK AND WHITE PHOTOGRAPH

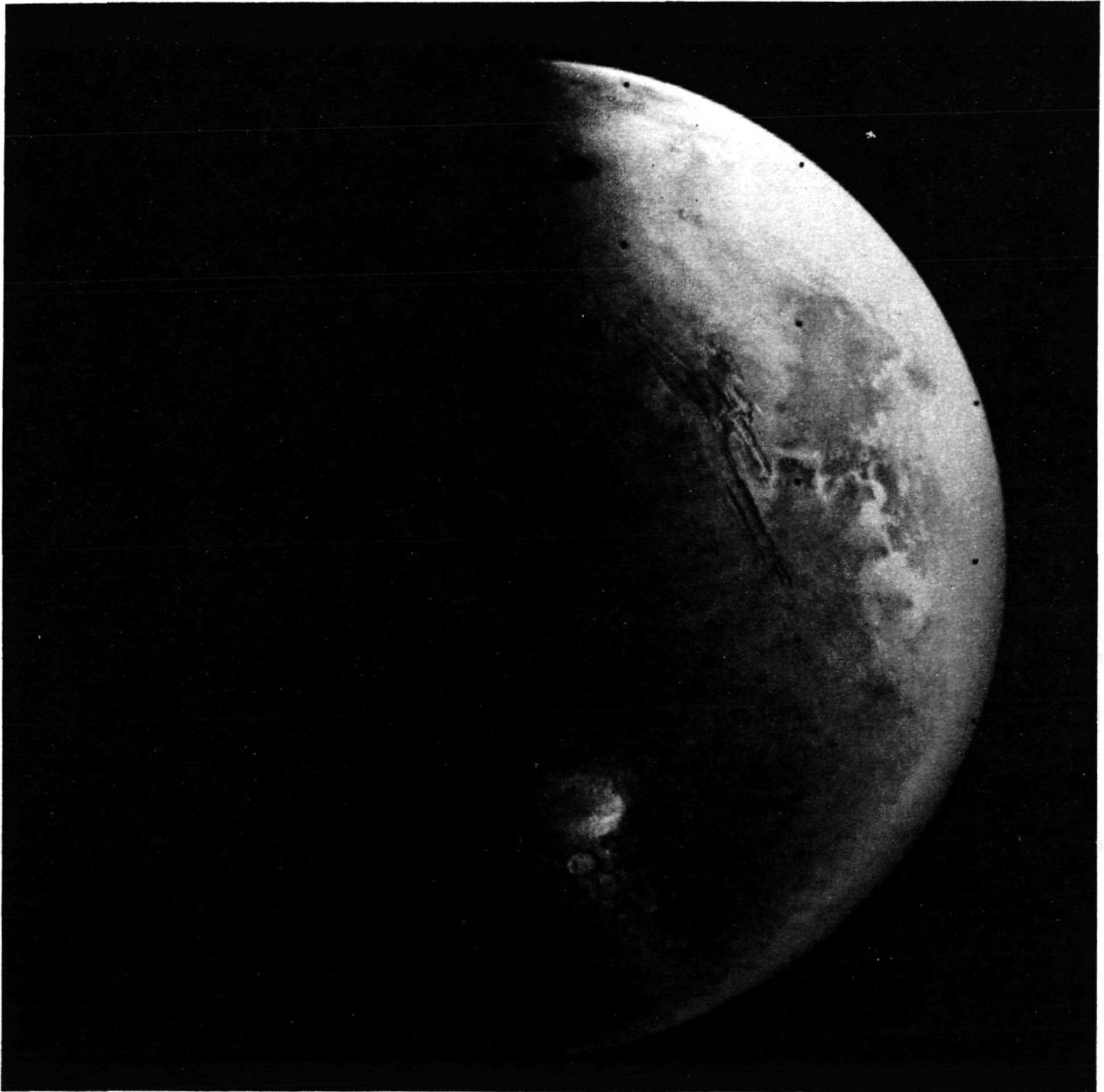

Fig. 5.12: The planet Mars. This photograph was taken by the Viking spacecraft still several million kilometers away, as it approached Mars for insertion into orbit. Many prominent surface features can be seen through the thin, clear, cloudless atmosphere. Note especially the dark, circular prominence to the north (just east of the terminator). Close inspection reveals a crater in its center. Viking approach photograph VO 75 170C26, MTIS 1018.

4. Do any craters on the Moon show "rays"?

.....
Is there any evidence of "rayed" craters on Mercury?
.....

5. Notice the flat region to the left center of the Mercury photograph. This is the eastern edge of a very large crater feature called the Caloris Basin – a lava-filled structure some 1300 km across. This is one of the largest and most interesting features on the surface of Mercury.

6. Examine Figure 5.12. Do the same features found on Mercury and the Moon also occur on Mars?

.....
.....
Are there any significant differences?
.....
.....

7. Examine the table listing the physical properties of the inner planets. List the major differences in physical properties among the Moon, Mercury and Mars. Next to each "difference," explain how it could affect the surface landscape.

8. Are there any factors, other than those you pointed out in No. 7, that could influence landscape features?

9. Using a compass, draw circles showing the relative sizes of the 3 planets and the Earth. How does the complexity of the surface features relate to the size of the individual planet?

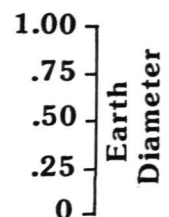

LANDFORM MAPPING: MOON, MERCURY AND MARS

(Instructor's Key)

OBJECTIVES

1. Using an Earth-based lunar photograph, you will describe and outline the following major geologic landforms: mare, highlands (terra) and major craters.
2. Through examination of full globe photographs, you will compare major landforms on the Moon, Mercury and Mars.
3. Through comparison of full planet photographs and the table of characteristics of the planets (endpapers), you will describe:
 - a. The major differences in physical properties for the three planets.
 - b. How observed differences in physical properties could influence the observed landforms.

MATERIALS

1. Grease pencil
2. Compass
3. Table of characteristics of the planets (endpapers)

PROCEDURE AND QUESTIONS

1. Examine Figure 5.10. Using the grease pencil, mark the boundaries of the different landforms on the Moon. Describe the characteristics of each landform which you marked.

Dark areas (maria) are flat, smooth, relatively uncratered; light areas (terrae) are rugged, bright and heavily cratered.

2. Which landform features, the light-colored highlands or the flat, dark maria, appears to be the most heavily cratered?

Light-colored highlands.

3. Examine Figure 5.11. What landforms do the Moon and Mercury have in common?

Uncratered plains, heavily cratered areas, bright-rayed craters.

4. Do any craters on the Moon show "rays"?

Yes

Is there any evidence of "rayed" craters on Mercury?

Yes

5. Notice the flat region to the left center of the Mercury photograph. This is the eastern edge of a very large crater feature called the Caloris Basin – a lava-filled structure some 1300 km across. This is one of the largest and most interesting features on the surface of Mercury.
6. Examine Figure 5.12. Do the same features found on Mercury and the Moon also occur on Mars?

Some, mostly craters.

Are there any significant differences?

More smooth plains in this view of Mars than on the Moon or Mercury.

7. Examine the table listing the physical properties of the inner planets. List the major differences in physical properties among the Moon, Mercury and Mars. Next to each "difference," explain how it could affect the surface landscape.

Gravity is higher on Mercury; would cause impact ejecta to be thrown a shorter distance than on Moon or Mars. Differences in density could cause differences in crust-mantle-core properties that in turn would affect volcanic and tectonic activity.

8. Are there any factors, other than those you pointed out in No. 7, that could influence landscape features?

Presence of atmosphere on Mars results in more effective gradation (weathering, erosion, etc.).

9. Using a compass, draw circles showing the relative sizes of the 3 planets and the Earth. How does the complexity of the surface features relate to the size of the individual planet?

The larger the planet, the more complex the surface.

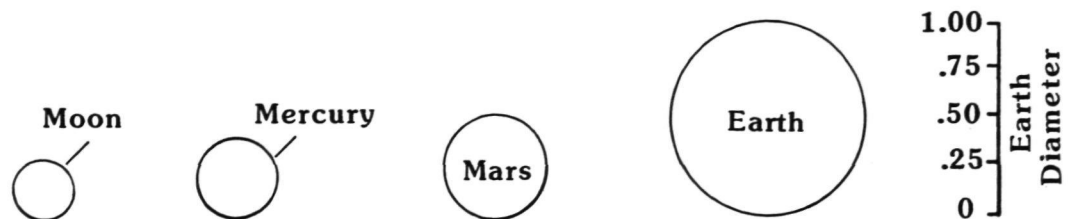

Name _____

Class _____ Date _____

GEOLOGICAL FEATURES OF MARS

OBJECTIVE

When you complete this exercise, you will be able to examine photographs of the surface of Mars and describe the dominant geological processes that have produced the landscapes shown in the photographs.

PROCEDURE AND QUESTIONS

PART A: VOLCANIC FEATURES OF MARS – AMONG THE MOST FAMOUS OF THE MARTIAN FEATURES ARE THE GIANT VOLCANOES

1. Figure 2.4
Location 18°N, 133°W
Olympus Mons

Olympus Mons is a shield volcano 550 km in diameter, towering 24 km above the surrounding plain. Around its base is an escarpment (steep cliff) which is up to 6 km high; its origin is unknown.

- a. Is the caldera on top of the mountain a simple crater or a complex system of craters?

.....

- b. What could cause the unusual structure of the caldera?

.....

.....

2. Figure 5.13
Location 13°24'S, 49°30'W
Equatorial plateau

This is the edge of the equatorial plateau region. The plateau was probably formed by a series of lava flows.

- a. What does the small number of craters on the plateau indicate about the probable age of the plateau?

.....

- b. Which agent of erosion could cause an escarpment such as shown here? Notice the edge is sharp without the branching channels typically found on Earth.

.....

ORIGINAL PAGE
BLACK AND WHITE PHOTOGRAPH

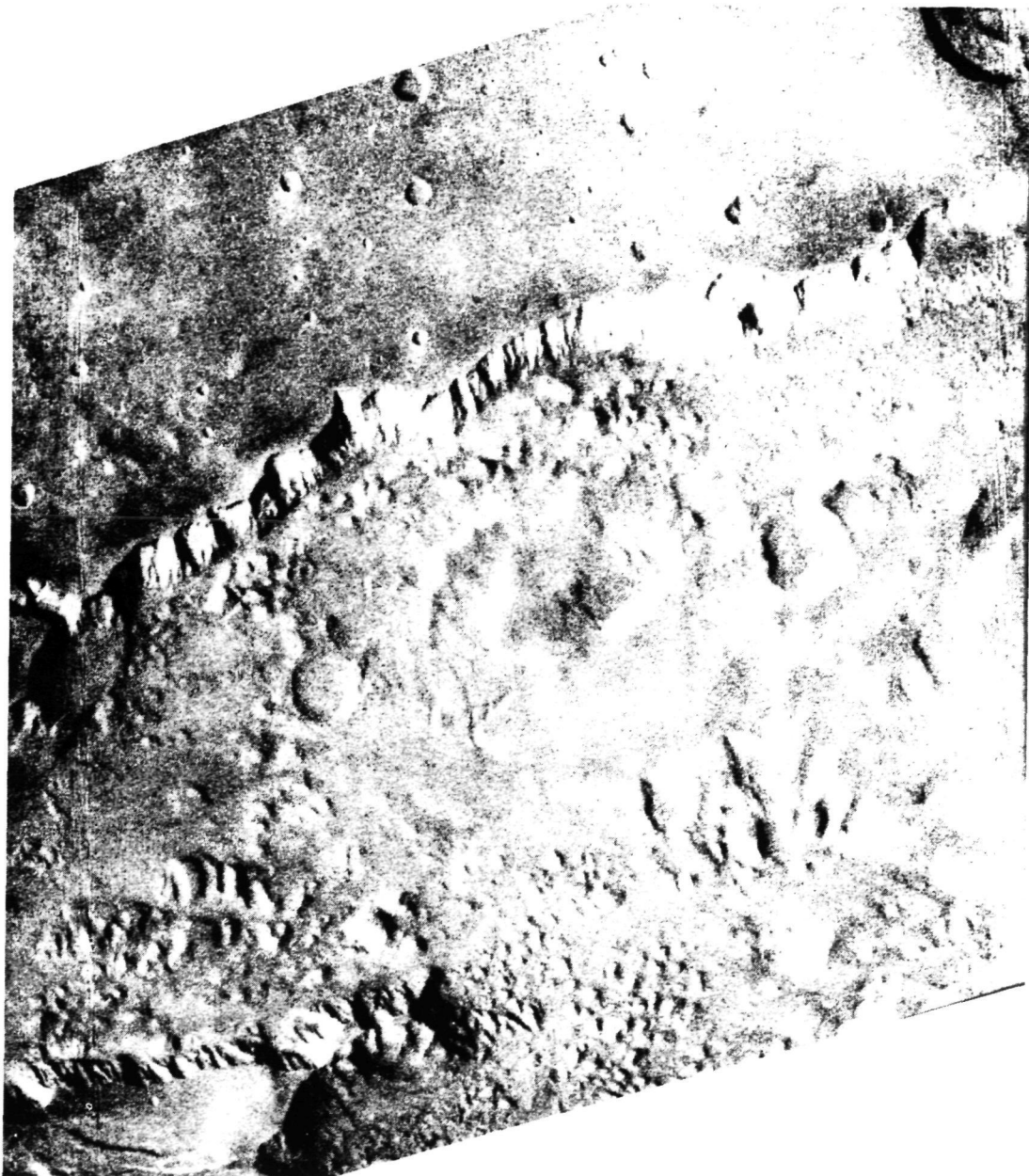

Fig. 5.13: Viking Orbiter photograph 338A17. An equatorial plateau on Mars. Width of the picture is approximately 220 km. North is to the top.

PART B: THE GREAT CANYONS

3. Figure 5.14
Tithonius Chasma, Location 5°S, 89°W
Ius Chasma

Note the general patterns of the canyons. Each canyon is about 60 km wide and 1 km deep.

- a. What type of feature on Earth does this landscape resemble?

- b. How might a feature such as this one form?

- c. There is a sharp ridge along the center of this canyon which should not be found in a typical water-cut canyon. What do you suppose caused this ridge?

PART C: EVIDENCE OF WATER ON MARS

4. Figure 5.15 and Figure 5.12

No liquid water has been found on Mars and little water is contained in the atmosphere.

- a. Where could water be trapped on Mars?

- b. How do we know that liquid water ever existed on Mars?

5. Figure 5.16
Location 4°N, 27°30'W
Tiu Vallis

Shown here is a channel about 45 kilometers wide. Note the flat areas near the channel banks, the small channels which seem to braid together, and the teardrop-shaped islands. This evidence points to erosion and deposition by water.

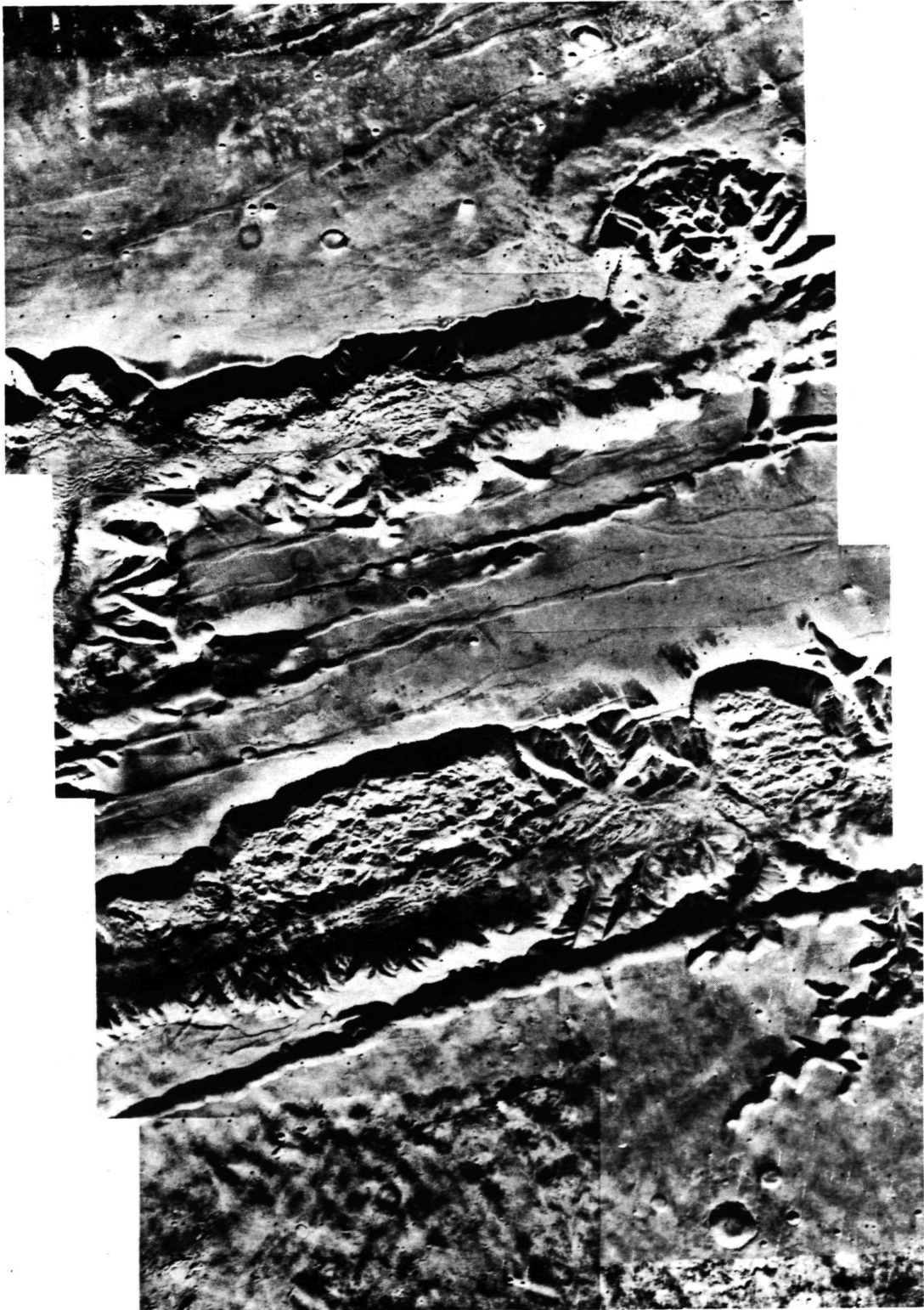

Fig. 5.14: Viking mosaic P-17708. Canyons just south of the martian equator. Each canyon is about 60 km wide and 1 km deep. North is to the top.



Fig. 5.15: U.S.G.S. mosaic of the surface of Mars. This chaotic terrain is located near 10°S , 43°W south of Chryse Planitia. The box canyon is about 40 km wide at its head. South is to the top.

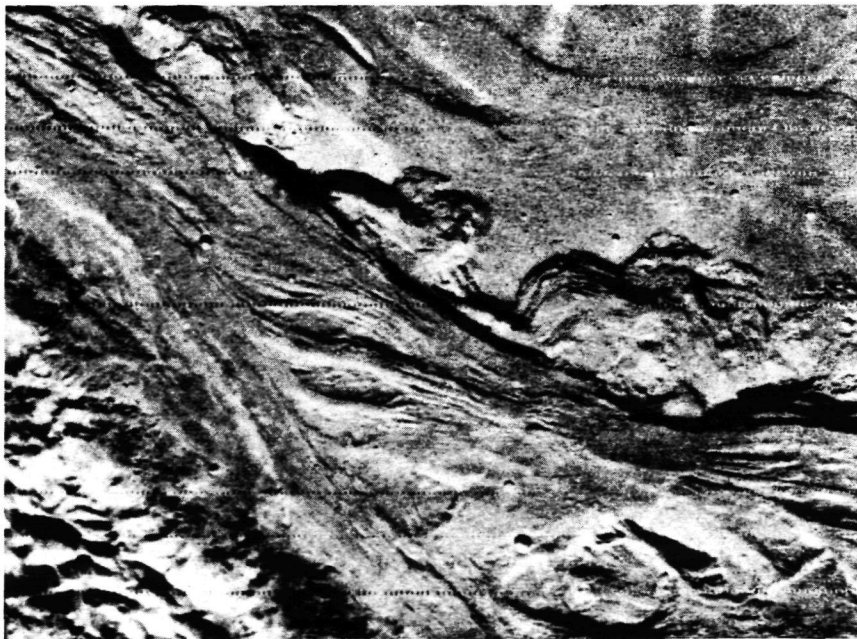

Fig. 5.16: Viking Orbiter photograph 83A38. A portion of Tiu Vallis on Mars. North is to the top.

ORIGINAL PAGE
BLACK AND WHITE PHOTOGRAPH

- a. What evidence is shown in the photograph to indicate the direction the water flowed?

.....
.....

- b. Examine the entire landscape shown in this photograph. Notice the bumpy, hummocky landscape around the channel. Note the channel. List the sequence of events that might have created this landscape from the first event to the present. Remember that the agents of erosion which have modified the landscapes on Mars are running water, wind and gravity.

.....
.....
.....

6. Figure 5.17
Location 17°N, 55°W
West of Chryse Planitia

Notice the series of channels apparently cut by running water.

- a. Were the channels cut before the period of cratering?

.....
.....

- b. What evidence is there for this conclusion?

.....
.....

- c. What evidence is shown to indicate the direction of stream flow?

.....
.....
.....

7. Figure 5.18
Location 22°N, 33°W
Eastern part of Chryse region

This view of the eastern part of the Chryse region is near the Viking I landing site. Note the teardrop-shaped features around the craters.

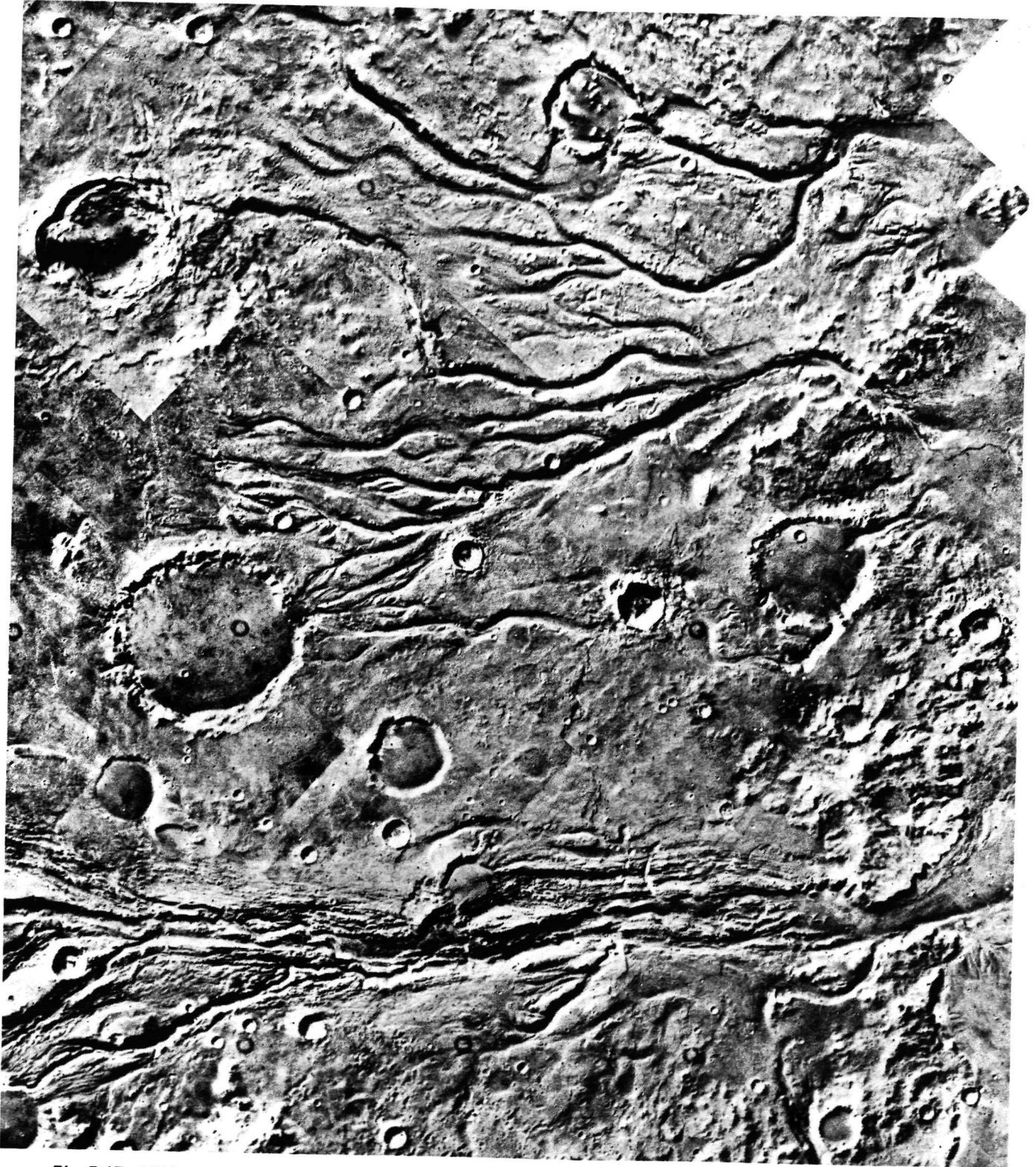

Fig. 5.17: Viking mosaic P-17688. Channels near the Viking Lander 1 landing site on Mars. Note the similarity to terrestrial drainage basins. Tributaries represent the head of the channel system.

ORIGINAL PAGE
BLACK AND WHITE PHOTOGRAPH



Fig. 5.18: Viking mosaic 211-4987. Part of Ares Valley on Mars. Channel beds and islands near the Viking Lander 1 site indicate ancient turbulent flow. The teardrop island is about 40 km long. North is to the top.

- a. What evidence is there to indicate the flow direction in this channel?

.....
.....

- b. Are all craters in this photograph older than the stream-type channel?

.....
.....

PART D: AEOLIAN FEATURES ON MARS

8. Figure 3.2
Location 47°S, 330°W
Hellasplottus

Winds on Mars are probably important landscape changing agents. Blowing at speeds of over 100 mph for long periods of time, they are capable of changing many surface features.

- a. What wind-produced landscape feature is shown on the floor of this large crater?

.....
.....
.....

- b. What evidence is shown in this photograph to indicate wind direction?

.....
.....

- c. What are the approximate dimensions of the ridges in the crater (width, length)?

.....
.....

- d. What does the presence of the ridges indicate about the type of material that makes up the martian surface in this area?

.....
.....

9. Figures 3.3 and 3.4

a. What evidence of wind erosion is shown here:

.....
.....
.....

b. How could wind direction be determined:

.....
.....

10. Figure 5.19

Location 47°N, 226°W
Utopia Planitia

Two theories have been advanced to explain the texture of the rocks seen at the Viking Lander 2 site: 1) they are volcanic and their surface is vesicular; that is, full of holes formed by gas escaping while they were still hot; and 2) they are probably igneous and have pits formed by the etching out of softer minerals by erosive action of windblown sand particles.

a. Examining other features in this photograph, what evidence indicates features due to action by wind?

.....
.....
.....

PART E: ANCIENT TERRAIN OF MARS

11. Figure 5.20

Location 24°S, 5°30'W
Sinus Meridiani

Among the oldest of the martian features are the heavily cratered areas. In areas such as these, many different processes may have operated to create the landscape shown.

a. From your knowledge of the factors that control the landscape form (internal forces such as volcanism, external forces such as erosion by water, the type of rock, such as lava or sand, and the amount of time involved), describe the role of each of these factors in creating the landscape shown:

Internal forces:

.....

.....

ORIGINAL PAGE
BLACK AND WHITE PHOTOGRAPHS

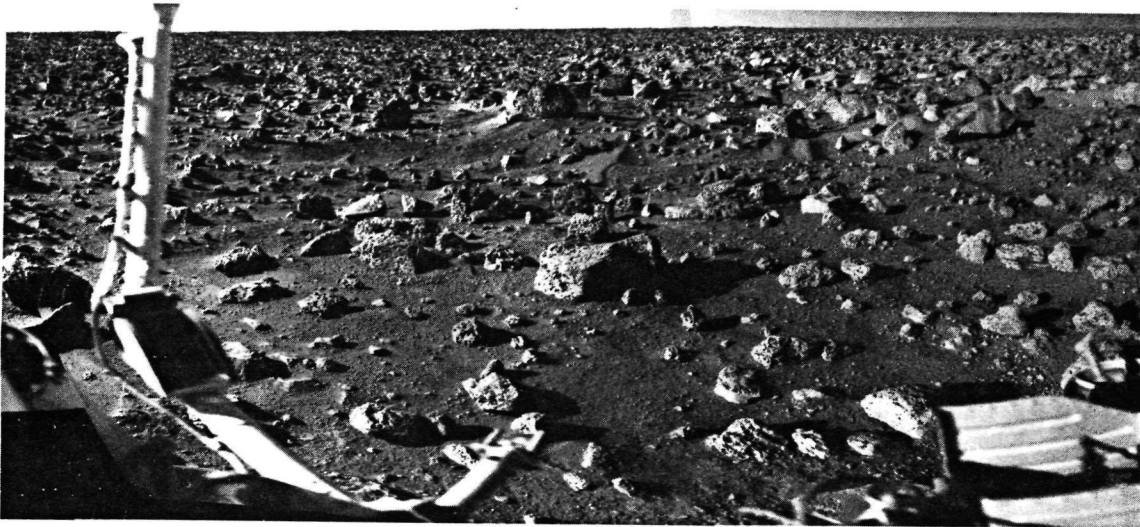

Fig. 5.19: The surface of Mars as seen by Viking Lander 2. JPL photograph 78/10/21/014626. Local time is 5:20 pm. The white vertical column on the left side of the picture is the Lander's meteorology experiment boom.

ORIGINAL PAGE
BLACK AND WHITE PHOTOGRAPH

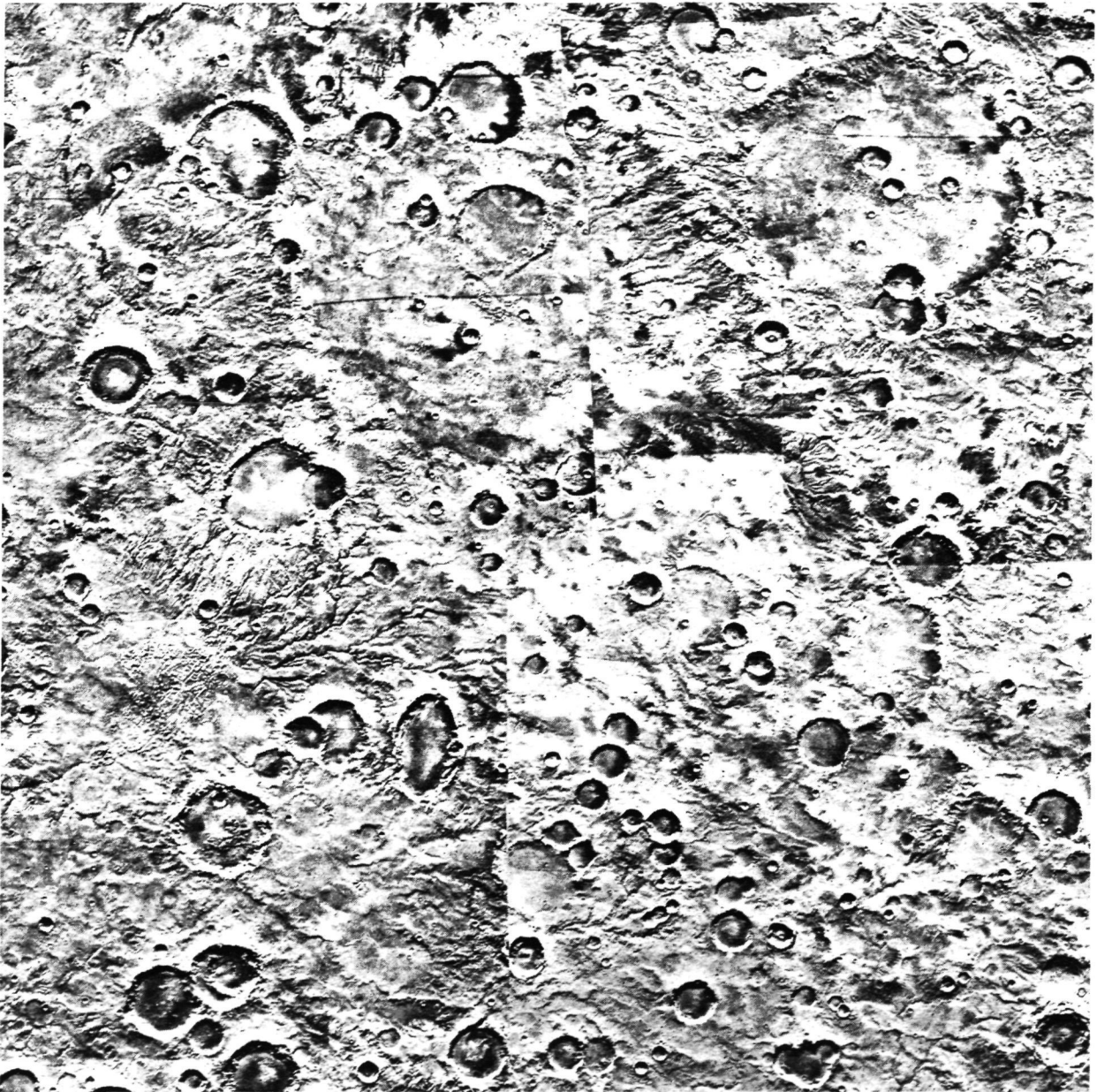

Fig. 5.20: Viking mosaic 211-5207. Ancient cratered martian terrain south of Sinus Meridiani. Note the variety of crater morphologies. Picture width is about 600 km. North is to the top.

External forces:

.....

.....

Nature of the surface material:

.....

.....

Time involved:

.....

.....

b. Are all of the craters shown about the same age? Explain.

.....

.....

.....

c. Why do some regions of Mars have a higher crater density than other regions?

.....

.....

.....

.....

.....

PART F: POLAR REGIONS OF MARS

12. Figure 5.21
Location 71°S, 30°30'W

In this portion of the south polar region is a series of ledges shown by the dark lines. Assume that each ledge is of similar thickness. The area shown is 88.5 by 63.5 kilometers.

a. Where on this photograph would the steepest terrain be found?

.....

.....

ORIGINAL PAGE
BLACK AND WHITE PHOTOGRAPH



Fig. 5.21: Mariner 9 photograph, NASA 72-H-813. The south polar region of Mars. The black dots in perfect array are not surface features, but calibration markings built into the Mariner 9 camera.

b. How is this photograph like a topographic map?

.....

.....

.....

c. Is there any evidence to show whether this area is an old landscape or a young one?

.....

.....

.....

13. Figure 5.22
Location 89°N, 200°W
North Polar Frost Cap

Like the Earth, Mars has polar ice caps. The view shown is during the martian summer. The ice cap measures about 1000 kilometers in diameter. There appear to be deposits of dust (windblown) interlayered with the ice.

a. What do the layers probably indicate?

.....

.....

b. Under what conditions could an ice cap of frozen carbon dioxide form?

.....

.....

14. Figure 5.23
Location 80°N, 48°W

This view of Mars' north polar ice cap shows the layered deposits beneath the cap and many topographic features surrounding the cap.

a. What agents of erosion were probably active in the creation of the landscape features shown in this photograph?

.....

.....

ORIGINAL PAGE
BLACK AND WHITE PHOTOGRAPH

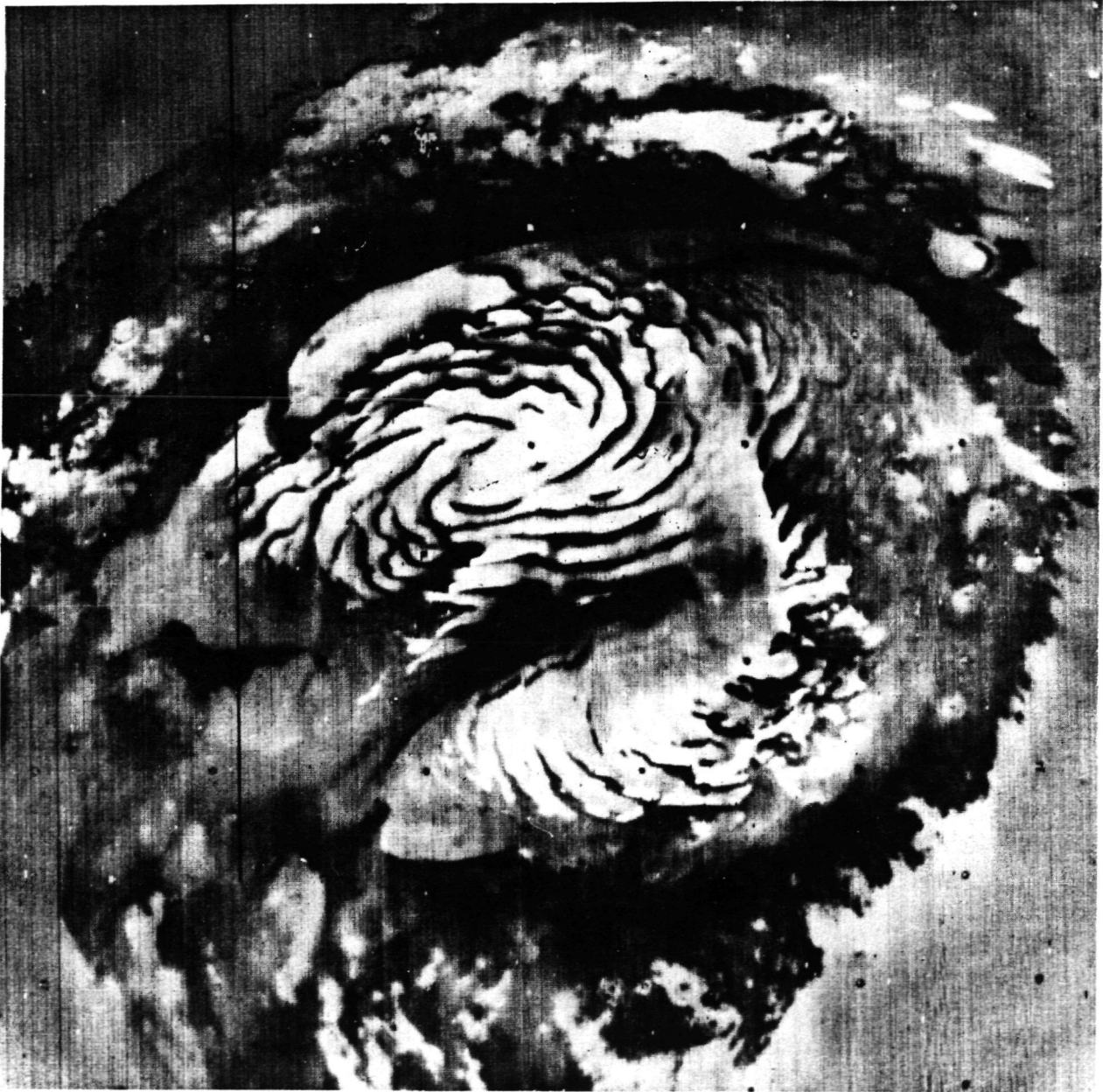

Fig. 5.22: Mariner 9 photograph 75-H-578. The martian north polar frost cap has receded to its minimum size.

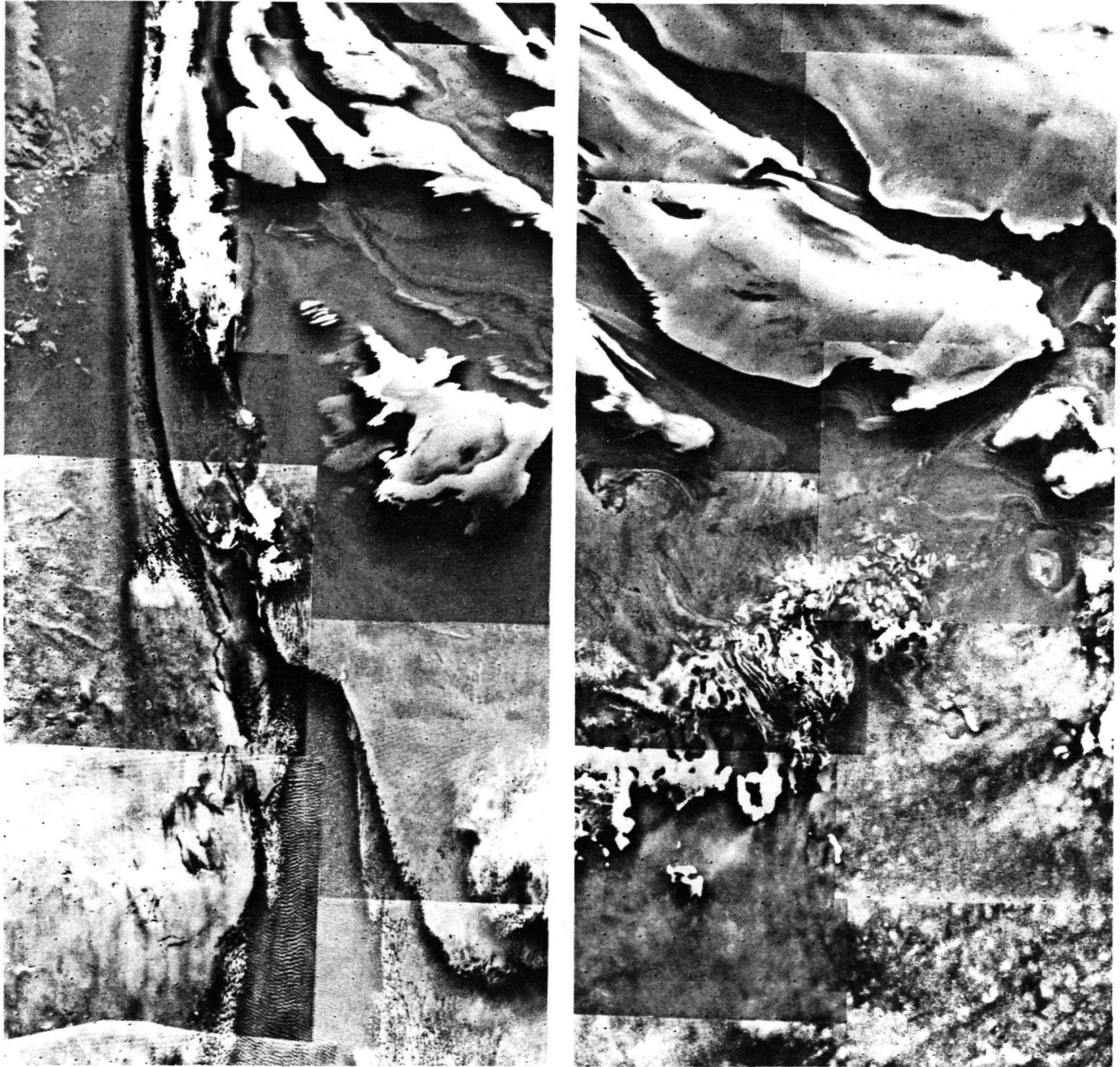

Fig. 5.23: Viking mosaic 211-5270. A portion of the edge of the north polar ice cap on Mars. The North Pole is beyond the top edge of the picture.

PART G: SUMMARY QUESTIONS

15. Figure 5.12
Full Globe View

Details seen on the close-up views are often not visible on full-planet photographs. Examine the full globe view and answer the following questions:

a. What types of landforms are visible on the full-planet view?

.....
.....

b. What evidence of volcanism is visible?

.....

c. Are there any impact craters visible?

.....

d. Could any one single factor be considered the most important one in creating the mar-
tian landscape? Explain your answer.

.....
.....
.....

e. From examination of the close-up views of Mars, what agents have been important in
creating the landscape of Mars?

.....
.....

f. Which of these agents is not visible on the full-planet view:

.....
.....
.....

GEOLOGICAL FEATURES OF MARS

(Instructor's Notes)

OBJECTIVE

Using photographs of the martian landscape, the student will be able to describe the dominant geologic forces which produced the landscape features examined.

DESCRIPTION

There are many reasons for studying other planets, not the least of which is to better understand our own planet and its evolution. The same basic erosional and weathering forces found on Earth also exist to some degree on some of the other planets. In this exercise, the student will examine photographs of Mars taken by spacecraft, and by careful analysis, draw conclusions about the events that have occurred. In the analysis of the martian photos it is important for the student to remember that four factors interact to produce the observed landscape features: 1) the nature of the surface materials, 2) internal forces, 3) external forces, and 4) time involved. Much of the surface of Mars is covered by either heavily cratered plains, windblown deposits, or polar ice. Volcanic deposits are common on Mars and cover extensive areas. The large volcanic features on Mars and vast tectonically-modified regions are the result of internal forces. Weathering and erosion are examples of external forces. The most active agents of erosion on the martian landscape appear to be wind (which produces extensive dune fields), running water (which produced some of the channels) and gravity (which is responsible for the mass wasting features of the canyon areas). Except for cratering, significant modification of landscape features by external forces has not occurred on the Moon and Mercury. The role of time in the creation of landscape features is of special significance. Few of the Earth's present landscape features are more than a few million years old, and there are almost no landscapes which are more than 10 million years old. Many martian features are several hundred million years old, some are even over a billion years old.

REFERENCES

Entire issue of the *Journal of Geophysical Research*, vol. 82, no. 28, September 30, 1977, scientific results of the Viking project.

Entire issue of the *Journal of Geophysical Research*, vol. 84, no. B 14, December 30, 1979, Second Mars Colloquium.

Entire issue of *Scientific American*, September, 1975.

Entire issue of *Science*, vol. 194, no. 4260, October 1, 1976.

PRE-LAB DISCUSSION

If students are not familiar with the factors that interact to produce landscapes, these factors should be discussed. The significance of the study of other planets is also an important area for discussion. Learning more about the Earth from the study of other planets is a point to stress through discussion.

GEOLOGICAL FEATURES OF MARS

(Instructor's Key)

PART A: VOLCANIC FEATURES OF MARS – AMONG THE MOST FAMOUS OF THE MARTIAN FEATURES ARE THE GIANT VOLCANOES

1. Figure 2.4
Location 18°N, 133°W
Olympus Mons

Olympus Mons is a shield volcano 550 km in diameter, towering 24 km above the surrounding plain. Around its base is an escarpment (steep cliff) which is up to 6 km high; its origin is unknown.

- a. Is the caldera on top of the mountain a simple crater or a complex system of craters?

It is a group or system of craters.

- b. What could cause the unusual structure of the caldera?

Multiple crater collapses within the caldera or explosive removal of the upper part of the caldera. A collapse could be caused by withdrawal of magma from below.

2. Figure 5.13
Location 13°24'S, 49°30'W
Equatorial plateau

This is the edge of the equatorial plateau region. The plateau was probably formed by a series of lava flows.

- a. What does the small number of craters on the plateau indicate about the probable age of the plateau?

The small number indicates that the plateau is relatively young.

- b. Which agent of erosion could cause an escarpment such as shown here? Notice the edge is sharp without the branching channels typically found on Earth.

Mass movement, such as landslides or slumping, would be responsible for this feature. There is little evidence of erosion by water.

PART B: THE GREAT CANYONS

3. Figure 5.14
Tithonius Chasma, Location 5°S, 89°W
Ius Chasma

Note the general patterns of the canyons. Each canyon is about 60 km wide and 1 km deep.

- a. What type of feature on Earth does this landscape resemble?

A canyon or a ravine.

- b. How might a feature such as this one form?

Answers will vary. Water or lava flows might be suggested. In fact the steep, sharp walls and huge dimensions argue for tectonic (crustal movement) causes. It is possible that local subsidence along fault lines caused the canyons.

- c. There is a sharp ridge along the center of this canyon which should not be found in a typical water-cut canyon. What do you suppose caused this ridge?

Answers will vary. The ridge may have been the result of block-faulting.

PART C: EVIDENCE OF WATER ON MARS

4. Figure 5.15 and Figure 5.12

No liquid water has been found on Mars and little water is contained in the atmosphere.

- a. Where could water be trapped on Mars?

In the polar caps. Although not obvious in the pictures, most geologists believe that significant amounts of water are trapped as ice in a permafrost layer.

- b. How do we know that liquid water ever existed on Mars?

Answers will vary. Some students may already be aware of erosional features on Mars and will therefore be able to answer correctly.

5. Figure 5.16
Location 4°N, 27°30'W
Tiu Vallis

Shown here is a channel about 45 kilometers wide. Note the flat areas near the channel banks, the small channels which seem to braid together, and the teardrop-shaped islands. This evidence points to erosion and deposition by water.

- a. What evidence is shown in the photograph to indicate the direction the water flowed?

The shape of the islands (tear-dropped). The pointed tail is directed downstream.

- b. Examine the entire landscape shown in this photograph. Notice the bumpy, hummocky landscape around the channel. Note the channel. List the sequence of events that might have created this landscape from the first event to the present. Remember that the agents of erosion which have modified the landscapes on Mars are running water, wind and gravity.

1. *Creation of hummocky terrain*
2. *Water erosion and creation of islands – terraces*
3. *Impact cratering*
4. *Wind erosion*

6. Figure 5.17

Location 17°N, 55°W
West of Chryse Planitia

Notice the series of channels apparently cut by running water.

- a. Were the channels cut before the period of cratering?

They were cut during the cratering period.

- b. What evidence is there for this conclusion?

Some channels cut across the craters, others are interrupted or superposed by craters. Thus, neither came first, but both were contemporaneous.

- c. What evidence is shown to indicate the direction of stream flow?

The channel's dendritic pattern indicates flow was from left to right. The branches feed into main channels in that direction.

7. Figure 5.18

Location 22°N, 33°W
Eastern part of Chryse region

This view of the eastern part of the Chryse region is near the Viking I landing site. Note the teardrop-shaped features around the craters.

- a. What evidence is there to indicate the flow direction in this channel?

The teardrop-shaped islands point downstream.

- b. Are all craters in this photograph older than the stream-type channel?

While some of the craters may pre-date the channel, the ejecta pattern in several is superimposed on channel features, thereby showing that these craters, at least, formed after the channel.

PART D: AEOLIAN FEATURES ON MARS

8. Figure 3.2
Location 47°S, 330°W
Hellasplontus

Winds on Mars are probably important landscape changing agents. Flowing at speeds of over 100 mph for long periods of time, they are capable of changing many surface features.

- a. What wind-produced landscape feature is shown on the floor of this large crater?

Dunes and dune-like structures. Whether it is "sand" cannot be determined from the pictures.

- b. What evidence is shown in this photograph to indicate wind direction?

The structures can be interpreted as transverse dunes because of the parallel, linear ridge configuration and close spacing (although the dunes are more complex than that). As on Earth the prevailing wind must be at right angles to the dunes. In this case the general wind direction is from the southwest. The dark streaks south of the dunes and other regional indicators not visible in the picture corroborate this.

- c. What are the approximate dimensions of the ridges in the crater (width, length)?

The distance between ridge crests is approximately 2 km. The length of any one ridge is between 10 and 20 km.

- d. What does the presence of the ridges indicate about the type of material that makes up the martian surface in this area?

It is unconsolidated sand-like material, unconsolidated because it can be moved around, and sand-like because our terrestrial experience requires it to form dunes.

9. Figures 3.3 and 3.4

- a. What evidence of wind erosion is shown here:

Bright and dark streaks emanate from craters in Figure 3.3 suggesting sediment transport by wind. The yardangs in Figure 3.4 are carved by wind.

- b. How could wind direction be determined:

The streaks "tail-out" of the crater with the wind; they are like wind socks at an airport. The fluted valleys between the yardangs are aligned with the wind. Detailed examination could reveal the direction along that axis.

10. Figure 5.19

Location 47°N, 226°W

Utopia Planitia

Two theories have been advanced to explain the texture of the rocks seen at the Viking Lander 2 site: 1) they are volcanic and their surface is vesicular; that is, full of holes formed by gas escaping while they were still hot; and 2) they are probably igneous and have pits formed by the etching out of softer minerals by erosive action of windblown sand particles.

- a. Examining other features in this photograph, what evidence indicates features due to action by wind?

There are several small, rippled, dune-like deposits present in the center of the photograph, indicating that a sustained wind blew across this region at some time in the geologic past.

PART E: ANCIENT TERRAIN OF MARS

11. Figure 5.20

Location 24°S, 5°30'W

Sinus Meridiani

Among the oldest of the martian features are the heavily cratered areas. In areas such as these, many different processes may have operated to create the landscape shown.

- a. From your knowledge of the factors that control the landscape form (internal forces such as volcanism, external forces such as erosion by water, the type of rock, such as lava or sand, and the amount of time involved), describe the role of each of these factors in creating the landscape shown:

Internal forces:

There appear to be ridges at various places between the craters, particularly in the southwest corner. They may be indicative of lava flows, where the ridges represent the leading edges, or lobes, of the flow.

External forces:

Impact cratering, erosion by water as shown by the dendritic channeling, and erosion by wind as shown by the dark patches and bright streaks in and around craters.

Nature of the surface material:

There is probably a covering of some loose-unconsolidated material covering a solid bedrock of igneous material (lava flows).

Time involved:

The number of different processes argue for an extended period of time from the earliest lava flows to cratering to channeling to wind erosion.

- b. Are all of the craters shown about the same age? Explain.

No, some craters are sharp and crisp and some are degraded or eroded.

- c. Why do some regions of Mars have a higher crater density than other regions?

- 1. Internal forces may not be as active as on other regions of the planet.*
- 2. External forces may not be equally active, i. e., wind and water erosion.*
- 3. Regions with a higher crater density may be geologically older.*
- 4. Surface material may bury some craters.*

PART F: POLAR REGIONS OF MARS

12. Figure 5.21
Location 71°S, 30°30'W

In this portion of the south polar region is a series of ledges shown by the dark lines. Assume that each ledge is of similar thickness. The area shown is 88.5 by 63.5 kilometers.

- a. Where on this photograph would the steepest terrain be found?

Where the lines are closest together, you would find the steepest terrain.

- b. How is this photograph like a topographic map?

The ledges in the terrain are like contour lines on a topographic map.

- c. Is there any evidence to show whether this area is an old landscape or a young one?

There are very few craters, which indicates that this is a relatively young area.

13. Figure 5.22

Location 89°N, 200°W

North Polar Frost Cap

Like the Earth, Mars has polar ice caps. The view shown is during the martian summer. The ice cap measures about 1000 kilometers in diameter. There appear to be deposits of dust (windblown) interlayered with the ice.

- a. What do the layers probably indicate?

Periodic deposition of ice, then dust, then ice; i.e. a seasonal extension and retreat of the ice cap with airborne sediment deposition between.

- b. Under what conditions could an ice cap of frozen carbon dioxide form?

It has to be cold and there has to be a source of carbon dioxide.

14. Figure 5.23

Location 80°N, 48°W

This view of Mars' north polar ice cap shows the layered deposits beneath the cap and many topographic features surrounding the cap.

- a. What agents of erosion were probably active in the creation of the landscape features shown in this photograph?

Aeolian — as shown by the dunes in the lower left part of the photograph.

Meteoroid impact — as evidenced by the few craters visible.

PART G: SUMMARY QUESTIONS

15. Figure 5.12 Full Globe View

Details seen on the close-up views are often not visible on full-planet photographs. Examine the full globe view and answer the following questions:

- a. What types of landforms are visible on the full-planet view?

Volcanoes, craters, canyons, plains.

- b. What evidence of volcanism is visible?

Volcanoes.

- c. Are there any impact craters visible?

Yes, especially the large basin to the south.

- d. Could any one single factor be considered the most important one in creating the martian landscape? Explain your answer.

It would be very difficult to attribute the creation of the martian landscape to any one factor because the nature of the planet is complex.

- e. From examination of the close-up views of Mars, what agents have been important in creating the landscape of Mars?

Wind and water erosion, impact cratering, volcanism, and tectonism.

- f. Which of these agents is not visible on the full-planet view:

Wind and water.

APPENDIX

HOW TO ORDER NASA MOTION PICTURES

The National Aeronautics and Space Administration produces films describing NASA research and development programs and achievements in space and aeronautics. These films may be borrowed for showings to educational, civic, industrial, professional, youth and similar groups. They may also be shown as unsponsored public service telecasts, unless otherwise indicated. Local video tape transfer is encouraged. Television stations with urgent requirements should call (202) 755-3500. There is no rental charge; however, borrowers must pay the cost of return postage and insurance.

When ordering a film, please give the name, address and zip code of the person and the organization assuming responsibility for the film. Films cannot be lent to minors. Please specify first and alternative choices of showing dates, and list any alternate film desired in case the requested film is not available. Please order films at least 30 days in advance of showing date.

NASA Regional Film Libraries

If you live in:

Connecticut
 Delaware
 District of Columbia
 Maine
 Maryland
 Massachusetts
 New Hampshire
 New Jersey
 New York
 Pennsylvania
 Rhode Island
 Vermont

Write to:

NASA Goddard Space Flight Center
 Public Affairs Office
 Code 202
 Greenbelt, MD 20771
 (301) 344-8101

Alaska
 Arizona
 California
 Hawaii
 Idaho
 Montana
 Nevada
 Oregon
 Utah
 Washington
 Wyoming

NASA Ames Research Center
 Public Affairs Office, 204-12
 Moffett Field, CA 94035
 (415) 965-6278

Alabama
 Arkansas
 Iowa
 Louisiana
 Mississippi
 Missouri
 Tennessee

NASA George C. Marshall Space Flight Center
 Public Affairs Office, CA-20
 Marshall Space Flight Center, AL 35812
 (205) 453-0040

Florida
 Georgia
 Puerto Rico
 Virgin Islands

NASA John F. Kennedy Space Center
 Public Affairs Office
 Code PA-EPS
 Kennedy Space Center, FL 32899
 (305) 867-4444

Kentucky
North Carolina
South Carolina
Virginia
West Virginia

NASA Langley Research Center
Mail Stop 145B
Technical Library
Hampton, VA 23665
(804) 827-2634

Illinois
Indiana
Michigan
Minnesota
Ohio
Wisconsin

NASA Lewis Research Center
Office of Educational Services
21000 Brookpark Road
Cleveland, OH 44135
(216) 433-4000 ext. 708

Colorado
Kansas
Nebraska
New Mexico
North Dakota
Oklahoma
South Dakota
Texas

NASA Lyndon B. Johnson Space Center
Public Information Branch
Film Distribution Library
Houston, TX 77058
(713) 333-4980

Alaska requesters may also obtain selected NASA film from:

Alaska State Library
Pouch G
Juneau, Alaska 99801

Requests for NASA films within the Hawaiian Islands can also be referred to The Department of Education, State of Hawaii, Office of Library Services, Support Services Branch, 641-18th Avenue, Honolulu, HI 96816

1. For further information, call NASA Audio Visual (202) 755-3500.
2. Alaska requesters may also obtain selected NASA film from: Alaska State Library, Pouch G, Juneau, AK 99801.
3. Requests for NASA films within the Hawaiian Islands can also be referred to The Department of Education, State of Hawaii, Office of Library Services, Support Services Branch, 641-18th Avenue, Honolulu, HI 96816.

HOW TO ORDER NASA PUBLICATIONS

NASA also publishes a variety of beautifully illustrated books and pamphlets on a wide range of topics. These publications are extremely useful to educators. A pamphlet describing these publications can be obtained by writing directly to:

Education Services
LCG-9
National Aeronautics and Space Administration
Washington, DC 20546

A NOTE ABOUT PHOTOGRAPHS

An essential part of Planetary Geology is the use of spacecraft photographs. Ideally each student or student-team should have access to glossy photographic prints for use during the laboratory exercises. Photocopies of the pictures in this book (such as xerox copies) generally lack sufficient detail to be useful. Offset printing is slightly better, but again this process is at least three generations removed from the original product.

Glossy prints or copy negatives can be obtained for a nominal cost (in some cases for no charge) from various sources. Each spacecraft photograph caption in this book contains the necessary picture identification numbers to help you in obtaining the photos. Usually the mission name (Apollo, Viking, etc.) and frame number is sufficient identification.

Listed below are several sources of space photography. Instructions for ordering photography will be provided upon written request. Be sure to include your name, title, the fact that the photographs will be used at a non-profit educational institution, and specific photograph numbers.

For planetary mission press release photos write to:

Goddard Space Flight Center
Public Affairs Office
Greenbelt, MD 20771

Jet Propulsion Laboratory
4800 Oak Grove Drive
Pasadena, CA 91103

For telescopic photography of the Moon write to:

Lick Observatory
University of California
Santa Cruz, CA 95064

For lunar mission photography write to:

Lunar and Planetary Institute
Photolibrary
3303 NASA Road 1
Houston, TX 77058

For general spacecraft photography write to:

Mr. Robert Vostreys
National Space Science Data Center
Code 601
Goddard Space Flight Center
Greenbelt, MD 20771

For spacecraft and high altitude aircraft photography of Earth and additional details on space photography and maps write to:

EROS Data Center
U.S. Geological Survey
Sioux Falls, SD 57198

SUGGESTED CORRELATION OF TOPICS

This activity

may be useful when teaching

UNDERSTANDING THE PHASES OF THE MOON

Celestial sphere
 Characteristics of the Moon
 Mapping of the Moon
 Motion of the Earth
 Motion of the Moon
 Principles of photography
 Solar and lunar eclipses
 Telescopic views of the Moon

IMPACT CRATERING
 COMPARING CRATERING PROCESSES
 IMPACT CRATERING ON A RAINY DAY



Conservation of energy
 Craters on the Earth, Moon, planets
 Kinetic energy
 Meteorites
 Sedimentation processes
 Space
 Strength of geologic materials
 Surface of the Moon
 Weathering and erosion

AEOLIAN PROCESS: MARTIAN WIND TUNNEL

Aerodynamics
 Air and its properties
 Arid lands
 Climate
 Deserts
 Effect of wind
 Environments
 Erosion
 Landforms
 Meteorology
 Weather

CORIOLIS EFFECT
 CORIOLIS EFFECT: DEMONSTRATION I
 CORIOLIS EFFECT: DEMONSTRATION II



Air and its movements
 Atmospheres
 Circulation of air or sea
 Forces (physics)
 Mechanics (physics)
 Meteorology
 Ocean currents
 Physics
 Rotation of planets

STORM SYSTEMS

Air and its motions
Air masses
Atmospheres
Cyclonic storms
Forecasting weather
Fronts, cold and warm
Meteorology
Weather satellites
Winds

PHOTOGEOLOGIC MAPPING OF THE MOON:
THE PROVINCES
PHOTOGEOLOGIC MAPPING OF THE MOON:
STRATIGRAPHY

}

Deductive reasoning
Geologic time
Geometric relationships
Geomorphology
Logic
Maps
Moon
Physiographic provinces
Remote sensing
Rock record
Satellite observations
Scientific method
Sedimentation
Stratigraphy
Superposition
Weathering and erosion

THE PLANETS IN STEREO

Solid geometry
Stereoscopic photography

LANDFORM MAPPING: MOON, MERCURY
AND MARS

Comparison of planets
Geomorphology
Landforms
Planets, general
Space
Sizes of planets

GEOLOGIC FEATURES OF MARS

Craters
Erosion
Geologic time
Glaciers
Groundwater
Lava flows
Polar climates
Rivers
Tectonics
Volcanoes
Water in the atmosphere
Wind

SELECTED GLOSSARY FOR PLANETARY GEOLOGY

- ALBEDO.** The percentage of the incoming radiation that is reflected by a surface. A high albedo indicates a light-colored region, a low albedo indicates a dark region. Lunar maria have a low albedo; lunar highlands have a high albedo. Albedos may be different for different colors.
- APOLLO PROGRAM.** A United States space program with the principle objectives of landing a Man on the Moon, studying the Moon's surface and internal processes, and applying the knowledge gained to a better understanding of the Earth.
- AEOLIAN.** (1) Applied to deposits arranged by the wind. (2) Applied to erosive action of the wind and to deposits so formed.
- ASYMMETRIC.** Lacking a mirror image construction on both sides of a dividing line. In the case of craters any diameter should qualify as a dividing line for symmetry to apply.
- BARCHAN.** A dune having a crescent shape. This type of dune is most characteristic of inland desert regions. Barchan structures have been photographed on the surface of Mars.
- CALDERA.** A large volcanic depression, more or less circular in form and much larger than the included volcanic vents. Caldera may be formed by three processes: explosion, collapse and erosion.
- CALORIS BASIN.** A very large (1300 km) ringed basin on the surface of Mercury.
- CHRYSE PLANITIA.** A large plain on Mars which is the landing site for Viking I.
- CONES.** Small angular peaks, common on some mare and crater floors, formed by volcanism.
- COPERNICUS.** A well-known lunar impact crater about 90 km in diameter and possessing a well-defined ejecta blanket with long rays; named for the Polish astronomer.
- CORIOLIS EFFECT.** The results of the Coriolis force (see Coriolis force).
- CORIOLIS FORCE.** The apparent force caused by the rotation of an object (such as the Earth) which serves to deflect a moving body on the surface. The Coriolis force causes ocean currents to be deflected to their right in the Northern Hemisphere on Earth.
- CRATER.** (1) A bowl-shaped topographic depression with steep slopes; (2) A volcanic orifice. Craters are formed by three processes: *impact*, as from a meteorite, *eruptive*, as from a volcanic eruption, and *explosive*, as from a nuclear blast. All three types are found on Earth. Only the first two have been seen on other planets.
- CRATERED TERRAIN.** An expanse of a planetary surface possessing a large number and variety of craters.
- CROSS SECTION.** A profile or vertical section through the surface to show possible rock structures beneath.
- CYCLONE.** A circular or nearly circular area of low atmospheric pressure around which winds blow counterclockwise in the northern hemisphere and clockwise in the southern hemisphere.
- DEIMOS.** The smaller of Mars' two moons, measuring 13 x 9 kilometers. Deimos orbits Mars every 30.3 hours in a west to east direction.
- DEPOSITION.** The laying down of potential rock-forming material; sedimentation.

DIASTROPHISM. The process or processes by which rock material is deformed.

DOME. Small, rounded hill. Often formed through igneous activity.

DUNE. A low hill or bank of drifted sand.

EJECTA. Any of a variety of rock fragments thrown out of a crater during formation and subsequently deposited ballistically on the surrounding terrain. The deposits themselves are called the ejecta blanket.

EOLIAN. See "Aeolian."

EROSION. The group of processes whereby rock material is removed and transported. There are four agents of erosion: running water, wind, glacial ice, and gravity (mass wasting).

ERUPTIVE CRATER. See "Crater."

EXPLOSION CRATER. See "Crater."

FLOOR. The low inner part or bottom of a crater.

FORMATION. The basic geologic unit used in mapping. A body of rock having recognizable upper and lower boundaries easily distinguishable from other materials and large enough to be a practical mapping unit.

GEOLOGIC MAP. A drawing, usually in color, which indicates surface geologic structure in a region.

GEOMORPHOLOGY. The branch of geology which deals with the form of the Earth and the changes which take place in the evolution of land forms.

GRADATION. The process of weathering rocks by disintegration and decomposition so that they can be eroded, transported and deposited in other areas. Gradation acts through the agents of erosion.

HIGHLAND TERRAIN. See "Terraes."

IGNEOUS. Rock type formed from molten rock material; process involving molten rock material.

IMBRIUM BASIN. The largest of the lunar basins; probably formed as a result of impact from a large comet or asteroid with the Moon about 3.95 billion years ago. The many concentric rings appear to be faults produced by gravitational collapse following the impact event which created the basin.

IMPACT CRATER. See "Crater."

JOVIAN PLANET. The major, or giant, planets that are characterized by great total mass, low average density, and abundance of the lighter elements (notably hydrogen and helium). The jovian planets are Jupiter, Saturn, Uranus, and Neptune.

LANDFORM. Surface features such as mountain ranges, plains, and canyons.

LAVA. Molten rock (magma) or such material after cooling.

LAVA FLOW. A sheet of cooled lava.

LUNAR HIGHLANDS. The light-colored, heavily cratered mountainous part of the lunar landscape.

LUNAR ORBITER. A series of five unmanned spacecraft launched in the 1960's to gather photographic data about the Moon (U.S.).

MAGMA. Molten rock material generated beneath the surface of a planet.

MARE (singular), MARIA (plural). The smooth, flat plains areas of the Moon. Maria can be recognized by their low albedo (dark appearance). They consist of basaltic lavas overlain by regolith.

MARE ORIENTALE. A 900 kilometer circular basin located on one edge of the Moon, as seen from Earth.

MARINER. Star-locked unmanned U.S. Spacecraft used for electromagnetic (including photographic) and gravitational studies of the planets.

MASCONS. "Mass-concentrations" indicating regions of high density material. Mascons are commonly found within some lunar basins.

METEOR. The luminous phenomena which occurs when a meteoroid enters the Earth's atmosphere.

METEORITE. A meteoroid that has survived its flight through the atmosphere and lands on the surface of a planet.

METEOROID. A meteoritic particle that is still in space.

MOSAIC A picture formed by matching together parts of two or more overlapping photographs.

OLYMPUS MONS. Formerly called Nix Olympica; the largest of the martian volcanoes. Located at 18°N, 133°W. It is a shield volcano 500 km in diameter and 24 km in height above the surrounding plains.

PETROLOGY. The study of rocks

PHOBOS. The largest of the two martian moons. Measures 23 x 16 km and revolves once every 7.7 hours in a west to east direction with a synchronous rotation.

PHOTOMOSAIC. See "Mosaic."

PIONEER. A class of spin-stabilized spacecraft; the first exploration of Jupiter was conducted by Pioneers 10 and 11.

PLANETARY ACCRETION. The process by which planets are believed to have grown to their present size by the accumulation of much smaller bodies into a single large mass by gravitation.

PLANETARY GEOLOGY. The study of the geology of the Moon, planets, and other solid surface objects.

PLANETESIMAL. Large bodies in the solar system which are less than planet size.

RAYS. Light-colored streaks radiating from impact craters.

REGOLITH. The entire layer or mantle of fragmental and loose rock material.

RELATIVE TIME SCALE A time scale based on the order in which a series of events occurred.

RILLES. Channel-like depressions on the lunar surface. Three basic types have been identified; linear rilles are large, relatively straight depressions often several kilometers wide and hundreds of kilometers long. They cut across crater rims. Sinuous rilles are generally found on lava surfaces and are thought to be lava channels or collapsed lava tubes. Irregularly branching rilles are thought to be formed by fracturing.

RINGED BASINS. Large crater-formed basins, such as the Imbrium Basin on the Moon or the Caloris Basin on Mercury, that contain one or more topographically raised rings. They are thought to represent impact scars from planetesimals. It is possible that such structures occurred on Earth, but tectonic processes and erosional forces have masked the structures.

RIM. The raised outer edge of a crater.

RIMA. The International Astronomical Union's Latin term for rille (see RILLES).

ROTATION. The act of spinning about an internal axis.

SATELLITE. A small body in orbit around a larger object. The Earth is a satellite of the Sun. The Moon is a satellite of the Earth.

SECONDARY CRATER . Formed when blocks ejected from a primary crater strike the surrounding surface, creating another crater.

SELENOLOGY. The study of the Moon.

STRATIGRAPHY. The branch of geology which treats the formation, composition, sequence and correlation of stratified rocks.

SUPERPOSITION. The order in which rocks are placed above one another. The Principle of Superposition states that in an undisturbed sequence of rocks, the oldest rocks should be on the bottom of the sequence.

TERMINATOR. The dividing line between light and darkness on a planet (day/night line).

TERRAE. The highland regions of the Moon. Typically, the terrae are heavily cratered with large, old-appearing craters on a rugged surface with high albedo.

TERRESTRIAL PLANET. The Earth-like planets possessing solid crusts. The terrestrial planets are Mercury, Venus, Earth, Mars, and possibly Pluto. Many of the satellites also may be terrestrial in nature. Terrestrial planets are characterized by a smaller diameter and higher percentage of the heavier elements than the Jovian or major planets.

UNIFORMITARIANISM . A geological principle proposed by Hutton which basically states that the present is the key to the past. Processes at work today on the surface are the same processes which have been in effect throughout time. Through the study of present processes, it is possible to understand past events.

VIKING. U.S. Mariner-class spacecraft for the exploration of Mars. Two orbiters and two landers.

VOLCANISM. A form of igneous activity involving the extrusion of magma at or near the surface,

VOLCANO. A vent in the crust from which molten lava, gases and/or pyroclastic materials issue. Volcanic cones are of three basic forms: *shield*, which is composed of lava sheets, *cinder*, which is composed of volcanic ash, and *composite*, made of alternating lava and ash layers.

VOYAGER. U.S. Mariner-class spacecraft used for the exploration of the Jovian planets.

WEATHERING. The processes whereby rocks chemically change and/or physically decay and crumble in response to surface conditions.

WRINKLE RIDGES . A general term applied to a variety of lunar ridges which have subtle differences in morphology. Some wrinkle ridges appear to be low-angle thrust-faulted surfaces produced by compressional stresses, other ridges appear to be related to the emplacement of mare lavas.

YARDANGS . Irregular ridges formed by aeolian (wind) erosion.