

## THE DEVELOPMENT OF A UNIVERSAL DIAGNOSTIC PROBE SYSTEM FOR TOKAMAK FUSION TEST REACTOR

Richard Mastronardi and Richard Cabral  
American Science and Engineering, Inc.  
Dennis Manos

Princeton University Plasma Physics Laboratory

### ABSTRACT

The Tokamak Fusion Test Reactor (TFTR) being built at Princeton Plasma Physics Laboratory is the largest such facility in the U.S. and places tremendous demands on the instrumentation in general and mechanisms in particular. This paper discusses the design philosophy and detailed implementation of a universal probe mechanism for TFTR which utilizes the experience gained by designing and operating aerospace mechanisms.

### INTRODUCTION

The Universal Diagnostic Probe System is a mechanism that will insert several types of scientific plasma measuring instruments into the plasma edge of the Fusion Reactor. It must operate from below the reactor substructure and make a reliable and accurate insertion approximately 4.5 meters vertically from the stowed position. Provision is also made for rotating the instrumentation at the probe head and its 16 electrical conductors (2 of which are high voltage) 360 degrees at a varying rate, when in the fully extended or stowed position.

This mechanism must be exposed to harsh environments of temperature (in excess of 200°C), high vacuum (less than  $10^{-9}$  Torr), high radiation levels [ $4 \times 10^5$  rad (Si)], and high magnetic impulses (150 Tesla/sec), without outgassing contaminants to the fusion plasma. It must also operate reliably over an eight-year period, since breaking vacuum to repair the mechanism would be costly when the system is fully operational. It must also not fail in a position or manner that impedes the attainment of scientific data from other diagnostic instrumentation or cause the plasma to be unstable.

This paper discusses the design of the Universal Diagnostic Probe System and demonstrates how the mechanisms achieve their specifications.

Hardware developed for aerospace has traditionally demanded solution of challenging technical problems. Often these challenges are the result of harsh environmental and operational constraints. The design and development of scientific instrumentation for a nuclear fusion reactor such as Princeton Plasma Physics Laboratory's Tokamak Fusion Test Reactor (TFTR) offers engineers and scientists many of the same kinds of problems found in aerospace. In many ways, the environment found on TFTR combines all of the worst constraints we find in aerospace.

## Tokamak Fusion Test Reactor

The nation's first magnetic confinement device capable of producing a significant quantity of fusion energy is currently being constructed by Princeton University's Plasma Physics Laboratory (PPPL). The Tokamak Fusion Test Reactor (TFTR), the largest construction project to date in the U.S. fusion program, is scheduled to be operational at Princeton in 1982. The TFTR project is being funded by the U.S. Department of Energy (DOE) as part of its national program to develop nuclear fusion as a safe, economical and environmentally acceptable method of generating electricity for the long term.

Other earlier Tokamaks in the U.S. and other nations were built to study plasma confinement below reactor-level conditions; TFTR has been designed to attain reactor-level plasmas and to yield experimental data relevant to future fusion power plants.

Figure 1 shows an artist's rendition of TFTR.

### System Overview

The imposed environments (shown in Figure 2) and requirements placed on this probe system play a significant role in its design.

A cross section of the Tokamak torus is shown at the top of the figure. The probe system is below the torus and extends through the substructure (a 2-meter-thick concrete floor) to the test cell basement floor. The probe system consists of basically four elements: a vacuum envelope which can be isolated from the Tokamak by two gate valves, a guide tube which helps guide and position the probe during its vertical travel, the Vacuum Vessel Interface Section (VVIS) which provides 10-kV electrical isolation and accommodates thermally induced relative motion between the torus vacuum vessel and the rest of TFTR, and the probe tube itself (approximately 4.8 meters long) which resides in the test cell basement area when fully retracted and extends to the plasma edge when fully inserted. The probe tube also contains the mechanism for rotating interchangeable probe heads. The system is noncontaminating and its materials are chosen for their low-outgassing properties, in order to maintain a vacuum better than  $10^{-9}$  Torr.

The external environment is clearly harshest near the plasma. The magnetic flux of 60,000 gauss, the bake-out temperature of 150°C, the probe head temperature of 200°C, and the high radiation levels all place particularly difficult constraints on the choice of materials and limit the techniques acceptable to maintain 2-kV electrical potentials at various points throughout the system and to transmit data signals from the probe head instrumentation to the data-taking computer system with low noise immunity. Noise immunity must be 1 nanoampere or 1 microvolt from frequencies of dc to 1 megahertz.

## Design Features

The design of mechanisms for this system must maximize reliability in the TFTR environment. As a result, the probe system design and development have encountered many difficult subproblems including:

- How do you align and maintain alignment of a 9-meter-long vacuum envelope, with 6 interfaces, that experiences a variety of thermal gradients and excursions?
- What materials are best to survive and perform in the imposed environments? This includes lubrication of various mechanisms and guides.
- What structural design best survives the high electromagnetically induced lateral loads during plasma disruptions? These impulse loads can be as high as 1000 kg for 10 milliseconds spread over the top meter of the probe. A bent probe incapable of being withdrawn below the isolation gate valves would necessitate the breaking of system vacuum. When TFTR is fully operational, the cost associated with breaking vacuum can be staggering.
- What is the most reliable way to hoist and lower the probe?
- What is the most reliable way to rotate probe head instruments anywhere along the 4.5-meter vertical stroke?
- What is the most reliable way to get signal and bias wires to the probe head instruments and mechanisms?

The last three subsystems are shown in Figure 3 and will be the focus of our discussion.

### Vertical Drive:

The vertical drive system is one of the most crucial subsystems from a reliability standpoint. A failure of this system with the probe in the full-up or even a partially up position would have unacceptable cost and technical implications for the TFTR project. In addition to simply raising and lowering the probe, the system must position the probe relative to the plasma with good precision, repeatability, and knowledge.

Trade-offs were performed on different types of hoist methods to determine which method met the performance requirements with the maximum reliability. Also considered was the ability to incorporate a back-up system for getting the probe down below the gate valves if a failure occurred in the primary drive system.

Three basic types of drive systems were examined: rack and pinion, lead or ball screw and a continuous loop cable hoist. The rack and pinion was chosen for its reliability and its predictable precision.

The vertical drive system is shown in Section B-B and is located at the top of the vacuum envelope. A stepper motor drives a worm gear reducer, which in turn transmits torque to a rack and pinion system through a metal-bellows-type vacuum feed-thru. To reduce torque transmitted by the feed-thru and prolong its life, additional gear reduction is performed inside the vacuum envelope before the rack and pinion drive. A pair of angled guide rollers on the back side of the custom rack maintain proper gear engagement of the rack and pinion throughout the vertical stroke.

#### Rotary Drive:

A unique feature of this probe system is the rotary drive. It is located at the lower end of the moving probe tube and is contained within its own hermetically sealed housing. Thus, it utilizes conventional wet lubricants for maximum reliability without fear of contaminating TFTR.

Since the rotational drive system is also a critical subsystem, the design was chosen carefully. Particular emphasis was given to designing a system that is both reliable and independent from the vertical drive system. What is meant by independent here is that any type of failure on the rotational system or as a result of the rotation system would not preclude the probe from being withdrawn from the plasma to a position below the gate valves.

The purpose of this mechanism is to rotate the probe head 360 degrees at a selectable speed from 3.6 degrees/second to 90 degrees/second anywhere along the 4.5-meter vertical stroke.

Three basic types of rotational drives were explored; two of these have motors external to the vacuum housing tube and one has an internal motor.

One type of drive system studied involves a scheme whereby a motor external to the vacuum envelope drives a 5-meter shaft through a vacuum feed-thru. The probe tube slides vertically along the shaft.

Another type studied involves a motor outside the vacuum housing which drives a gear through a vacuum feed-thru. This gear engages the probe tube at distinct zones along the vertical stroke.

The design selected for use on this system and shown in Figure 3 has many advantages. The most important one is that no matter what happens in this subsystem, it will not prevent the probe from being safely withdrawn vertically below the isolating gate valve. The wires to drive the stepper motor and to receive encoder signals must however accommodate 4.5 meters of motion. Since the probe head signal and bias wires already have this requirement, it was convenient to combine the wires into one cable.

## Electrical Connection:

After many trade-off studies, a cable configuration was chosen that minimizes noise pickup in the high magnetic field, survives the operating environment and minimizes material outgassing. A flexible, shielded kapton sandwich cable has been designed which allows a mixing of conductor types. Flat conductors of various sizes can be combined with twisted pairs of polyimide-covered magnet wire in a single laminated cable. It is shielded with 2300 angstroms of copper electro-deposited around the cable before the last layer is assembled.

The cable is used in a "seat-belt retractor" type mechanism to maintain electrical continuity throughout the probe vertical stroke. The cable is shown in the retracted position in Figure 3. A cross section of the cable laminate is shown in Figure 4 and a photograph of a cable sample is shown in Figure 5.

## CONCLUSIONS

The technology developed for the design of aerospace instrumentation has wide-ranging applications; one given here is the development of a universal diagnostic probe system for TFTR. This instrument challenges the designer to formulate a design which operates reliably in each of the worst combinations of environments.

Some of the designs discussed here show that by isolating subsystems, reliability is increased. A failure in any of the many subsystems, such as the vertical insertion stroke drive, the probe head rotary drive and the electrical conductor take-up reel, will not cause a failure in any other subsystem or prevent the probe system from being withdrawn to a safe position below the isolation gate valve. This is an important consideration in the design of this mechanism and is an outgrowth of experience gained in designing complex spaceborne mechanisms where repair is expensive, if not impossible. The philosophy of isolating failures to distinct subsystems proves to be a key ingredient toward minimizing the impact of failures, if they occur, and providing responsive back-up scenarios. This scheme, coupled with designing simple, reliable mechanisms to start with, gives a mechanical system like the Universal Diagnostic Probe the necessary features to survive and operate satisfactorily in the harsh environment of TFTR.

## ACKNOWLEDGEMENT

This work was performed on Princeton Plasma Physics Laboratory subcontract S-01936-H under DOE Contract DE-AC02-76-CHO-3073.

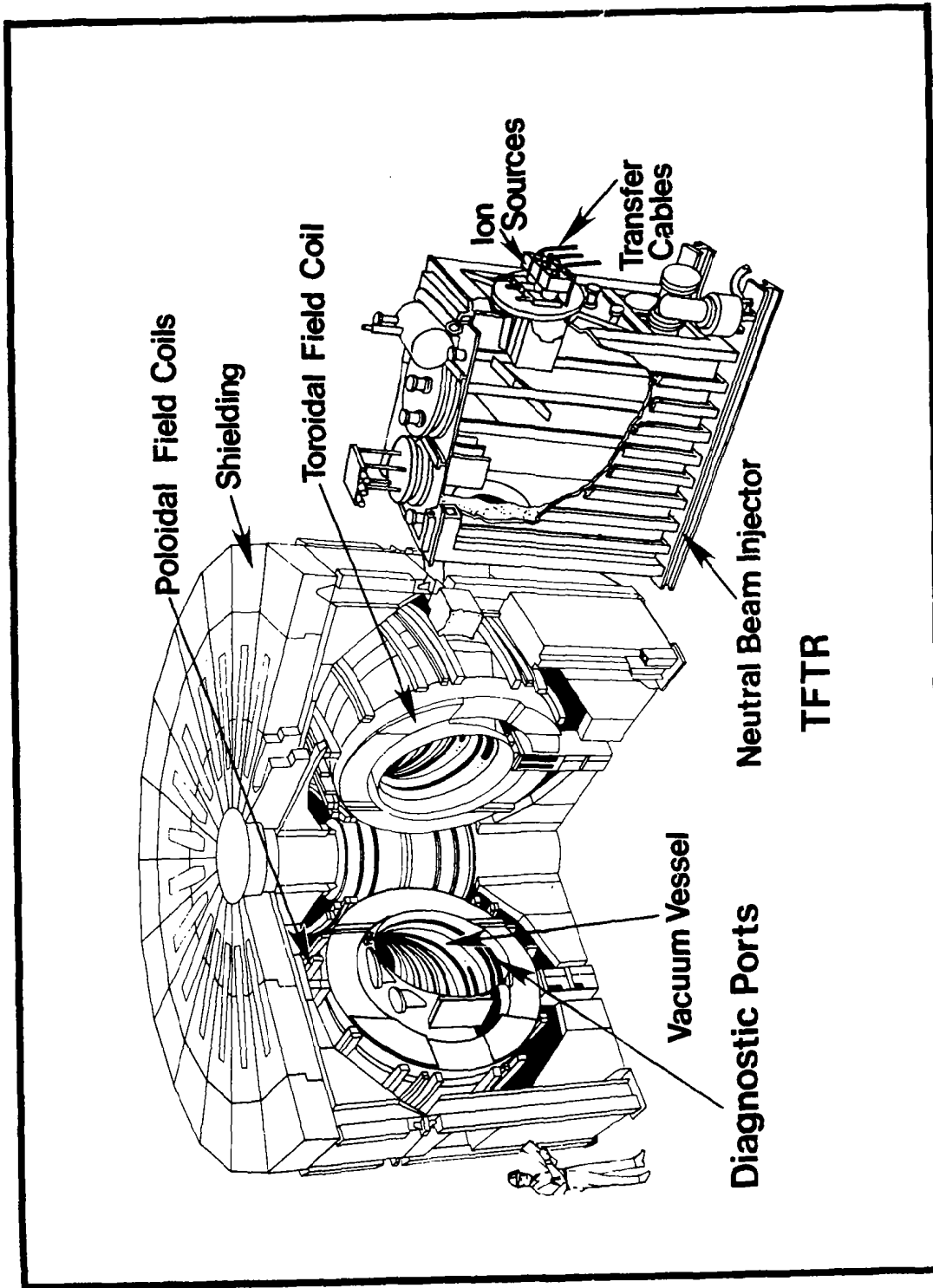

Figure 1. Artist's Rendition of TFTR

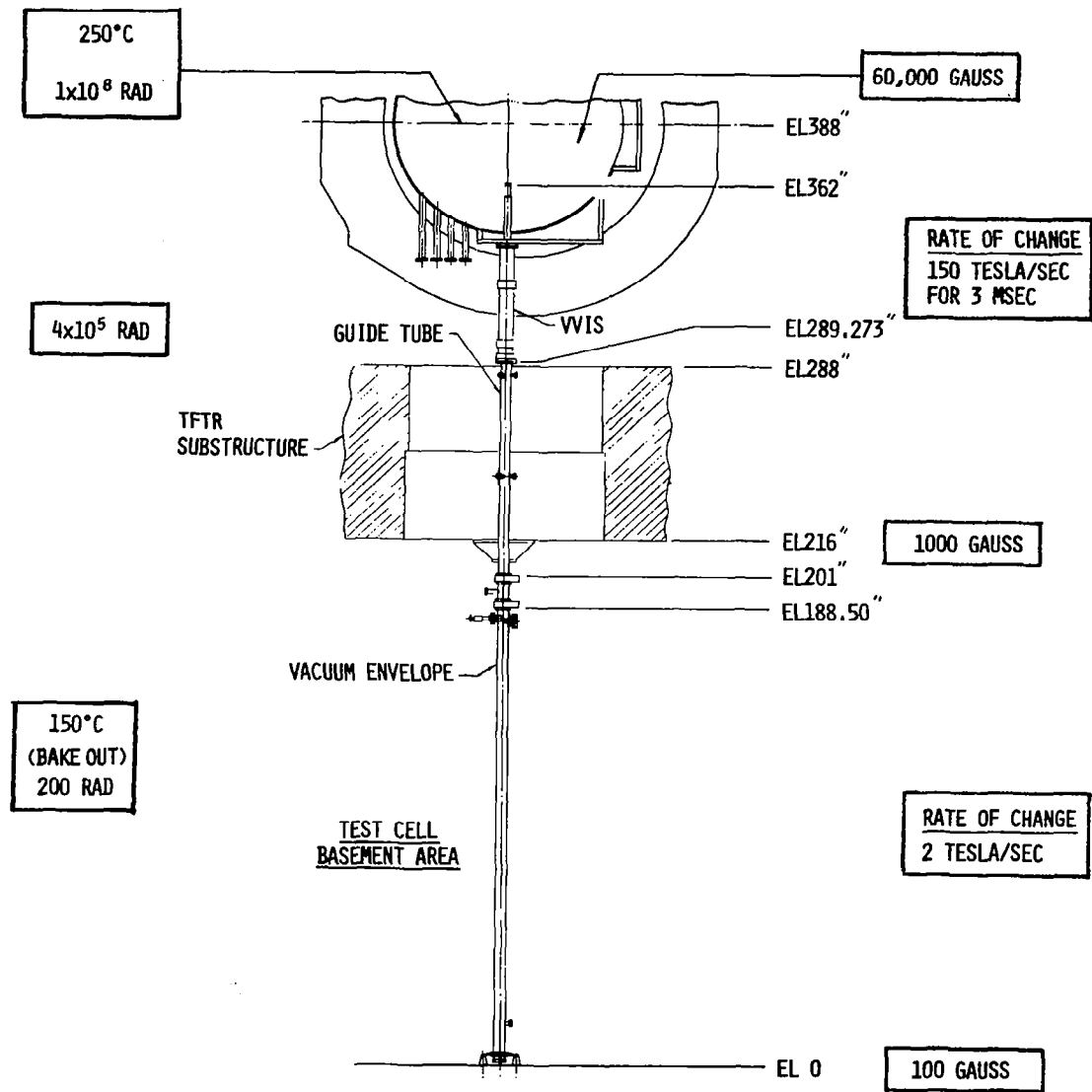

Figure 2. Environmental Schematic

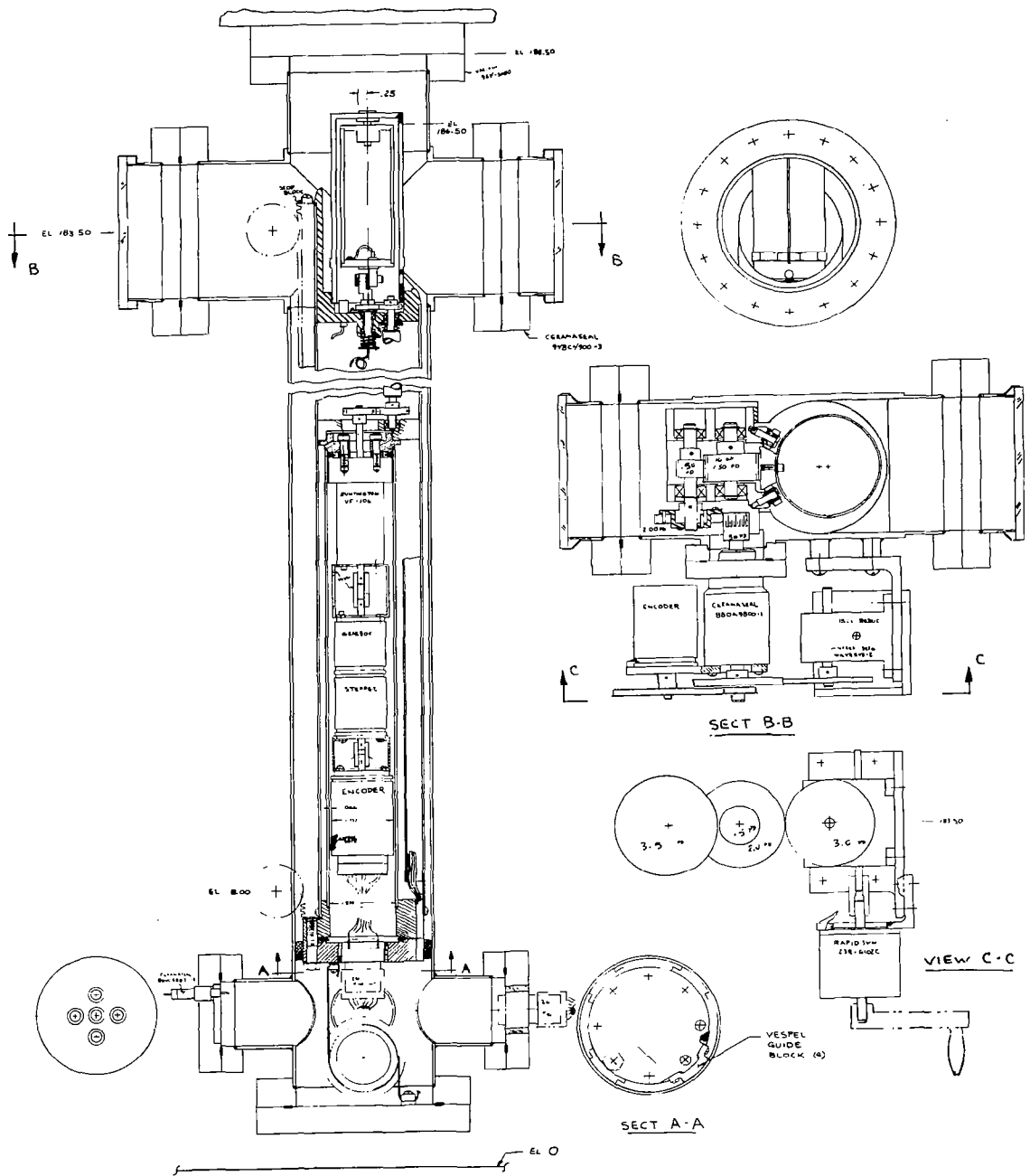
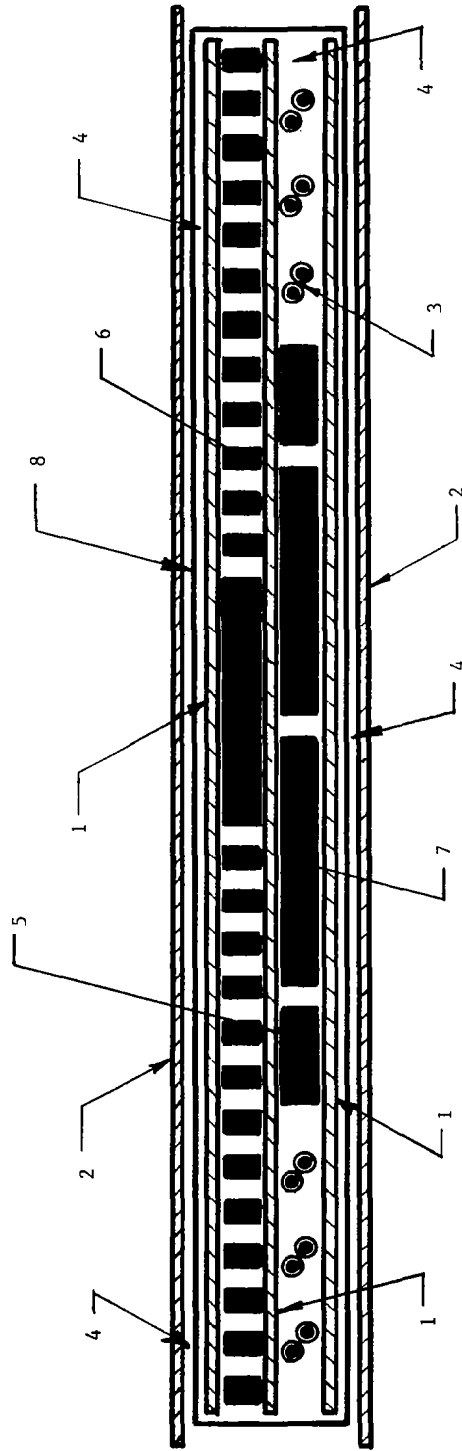

Figure 3. Probe System Layout





- |  |  |
|--|--|
| 1) 2 MIL KAPTON  | 5) 5 AMP CONDUCTOR                       |
| 2) 1 MIL KAPTON  | 1.4 MILS (1 OZ.) COPPER, 0.175 IN. WIDE. |
| 3) KAPTON COATED MAGNET WIRE IN TWISTED PAIRS, 0.004 IN. DIA. WIRE 0.0003 IN. KAPTON JACKET THICKNESS. | 6) .125 AMP TO 1 AMP CONDUCTOR           |
| 4) .7 MILS ACRYLIC ADHESIVE  | 1.4 MILS (1 OZ.) COPPER, 0.040 IN. WIDE. |
|  | 7) 10 AMP CONDUCTOR                      |
|  | 1.4 MILS (1 OZ.) COPPER, 0.450 IN. WIDE. |
|  | 8) E.M.I. SHIELD                         |
|  | 2300 ANGSTROMS COPPER                    |

Figure 4. TFTR Flex Cable Cross Section

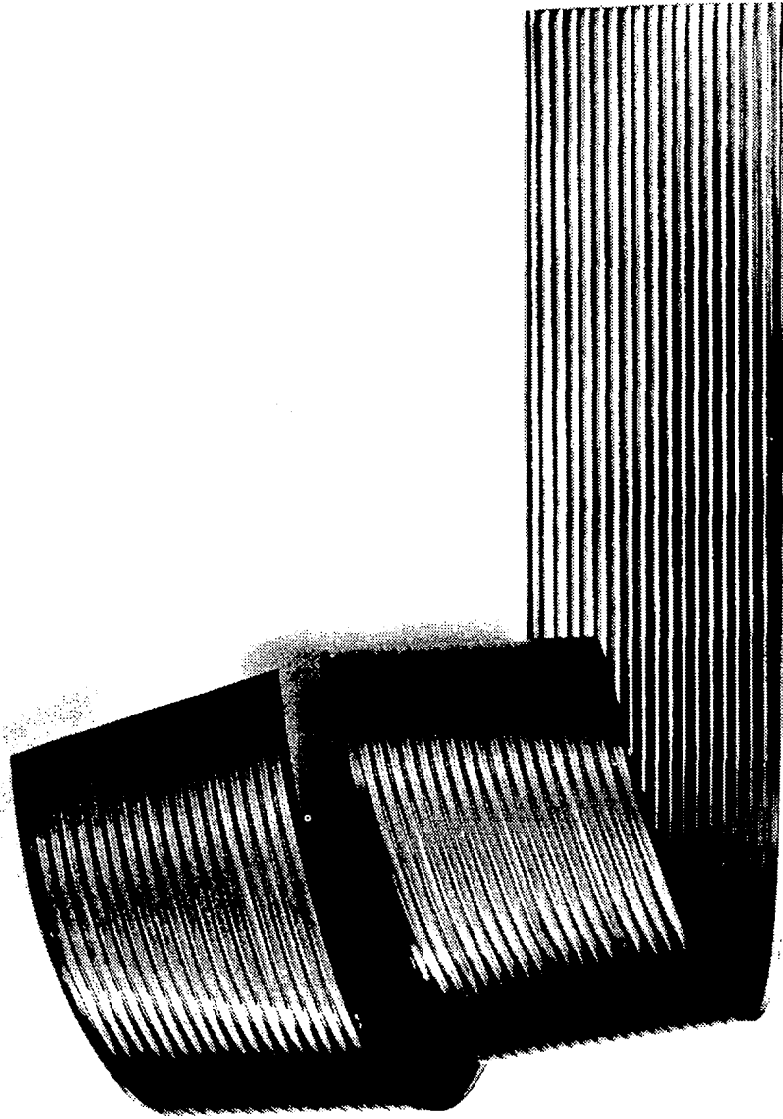

Figure 5. Kapton Sandwich Cable Sample

Richard Mastronardi  
American Science and Engineering, Inc.  
37 Broadway  
Arlington, Massachusetts 02174

Mr. Mastronardi is presently the Manager of Mechanical Engineering at American Science and Engineering. He was previously project engineer on the HEAO-2, High Energy Astronomy Observatory, and other astronomy payloads for NASA. Prior to his employment with American Science and Engineering in 1975, he worked for Atkins & Merrill, Inc., Sikorsky Aircraft, and The Boeing Company. Mr. Mastronardi holds a B.S. degree in Aeronautical Engineering from Rensselaer Polytechnic Institute and an M.B.A. from Northeastern University.

Co-authors of this paper are Mr. Richard Cabral who is also with American Science and Engineering and Mr. Dennis Manos who is affiliated with Princeton University.