

Dolo

THE DESIGN OF LOW-COST STRUCTURES FOR EXTENSIVE GROUND ARRAYS

H. A. Franklin and R. S. Leonard
Bechtel National, Inc., San Francisco, California

E N 82 22702

There is a great deal of similarity between the functional requirements for support structures for flat plate photovoltaic arrays and for the Satellite Power System (SPS) rectenna panels. Much work relevant to the SPS rectenna design effort has been done on developing design criteria and structural designs for low-cost support structures for terrestrial photovoltaic power plants.

This paper reports on the work done by Bechtel National, Inc. for Sandia Laboratories to develop conceptual designs of solar array support structures and their foundations including considerations of the use of concrete, steel, aluminum, or timber. Some cost trends were examined by varying selected parameters to determine optimum configurations. Detailed civil/structural design criteria were developed during this work. Using these criteria, eight detailed designs for support structures and foundations were developed and cost estimates were made. Cost estimates for array supports and foundations were shown to vary between \$2 to \$3 per square foot of supported panels (deflated to 1975 dollars).

A result of this study was to identify wind as the major loading experienced by these low-height structures, whose arrays are likely to extend over large tracts of land. The proper wind load estimating is essential to developing realistic structural designs and achieving minimum cost support structures. Existing building codes are not directly applicable for determining the wind loads on these structures. Consequently, wind tunnel testing of a conceptual array field was undertaken and some of the resulting wind design criteria are presented in this paper. SPS rectenna system designs may be less sensitive to wind load estimates, but consistent design criteria will remain important.

Concepts: In developing low cost support concepts for either the terrestrial photovoltaic power plants or SPS ground stations the functional requirements must be well understood. Some of these are:

- spacing requirements to avoid shading
- construction and maintenance access requirements
- environmental restrictions and construction materials (rusting, wood rot, degradation due to UV)
- size limitations due to transportation
- reflection/vibration limits

Concepts considered ranged from panels placed directly on the ground to having the energy collection system integrated into the sloping roof of a large building structure which also houses office and condominiums. Various foundation concepts were also reviewed. After a preliminary screening, the main study effort concentrated on simple structures made up of posts and beams. The posts were supported on caissons or footings, or were directly embedded in the ground. Several of these concepts are shown in the following pages.

Design Criteria: These low (close to the ground) light-weight structures are not governed by any of the existing categories of building codes such as the Uniform Building Code (UBC) or American National Standards Institute (ANSI) A.58.1-1972 "Building Code Requirements for Maximum Design Loads in Buildings and Other Structures." Yet for studies whose results will be widely used to

determine the economic feasibility of concepts, it is important to have specific design criteria.

Design criteria developed during the study of low cost structures for photovoltaic arrays addressed types of load, nature of the loading function (known/unknown, variable, upper bound) and risk of occurrence of the loads. The design criteria were developed along the lines of the above codes and used, in addition to those codes, the results of current research in assessment of risk and wind loading of civil engineering structures.

Cost Trends and Costs: A number of factors affect cost trends. Some of these are:

- cost of labor to install support components such as posts and beams declines as a function of $1/n$ where n is the number of panels supported per span
- material required for beams increases as a function of L^2 , where L is the distance between supports
- material required for foundations increases as a linear function of load on the columns or posts

The effects of combining these trends are shown in the attached figures...

Wind Design Studies: Usual design procedures like those given in ANSI A58.1-1972 are not adequate for accurate wind design of repetitive arrays of sloping solar panels set at a low height above the terrain. The technical literature provides little information even for a single array. Hence the wind tunnel test program was performed in 1979 for single flat panel arrays and for a field of such arrays. The 1:24 scale models were tested in the Meteorological Wind Tunnel at the Colorado State Fluid Dynamics Laboratory at Fort Collins, utilizing a boundary layer feature to generate terrain turbulence. Measurements were made of the effects of panel slopes, wind azimuth, panel porosity and height above the ground, and for the effects of wind barriers. The height above ground and changes in panel porosity, to the amount deemed reasonable for solar panels, were found not to have much effect on wind forces. On the other hand, porous fences provided large reductions in wind forces on either single arrays or on parts of array fields. Wind force coefficients derived from these studies are recommended for the wind design of similar solar panel installations. These are intended to represent mean wind effects and do not include wind dynamics. Existing methods for gust force design are recommended at this time.

THIS ASSUMES INSTALLATION OF LOW PANEL ARRAYS
USING COVENTIONAL EQUIPMENT

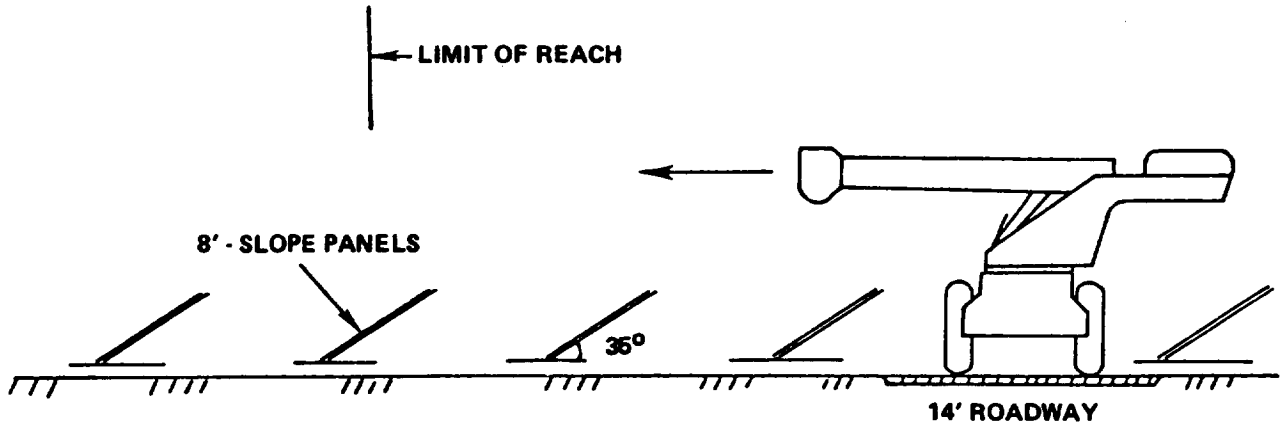

ARRAY SPACING AND ROADWAY ALLOCATIONS

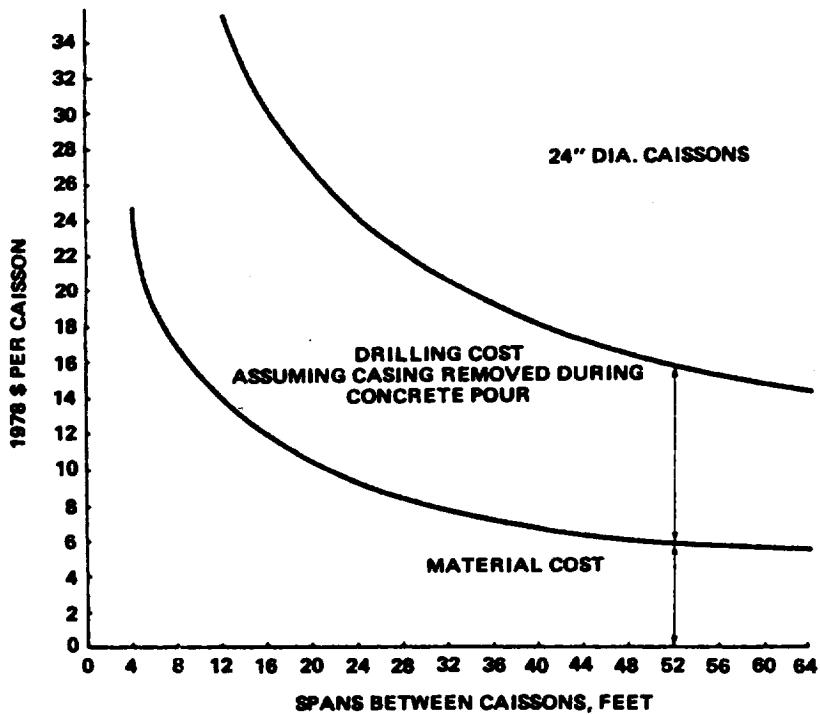

PRELIMINARY COST ESTIMATES
FOR 24" DIAMETER CAISSONS

ORIGINAL PAGE IS
OF POOR QUALITY

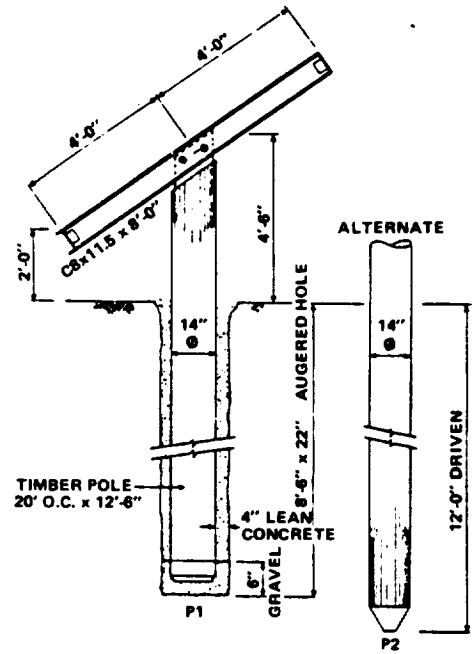
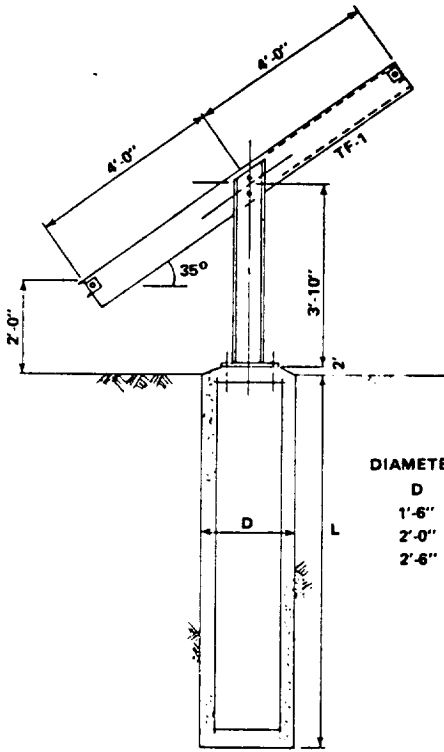

POLE FOUNDATIONS P1 AND P2
8' x 20' ARRAYS

VERTICAL CAISSON F-3, 8' x 20' ARRAYS

