

TIME TRANSFER BY IRIG-B TIME CODE VIA  
DEDICATED TELEPHONE LINK

G. Missout, J. Béland, D. Lebel, G. Bédard and P. Bussière,  
Institut de recherche d'Hydro-Québec Hydro-Québec

ABSTRACT

Measurements were made of the stability of time transfer by the IRIG-B code over a dedicated telephone link on Hydro-Québec's microwave system. The short-and long-term Allan Variance was measured on both types of microwave system used by Hydro-Québec, one of which is synchronized, the other having free local oscillators. The results promise a time transfer accuracy of 10  $\mu$ s. The paper also describes a prototype slave clock designed to detect interference in the IRIG-B code to ensure local time is kept during such interference.

1. INTRODUCTION

Hydro-Québec's requirements with regard to time dissemination cover a wide range.<sup>1</sup> As far as voltage phase angle measurements are concerned, it calls for an accuracy of 10  $\mu$ s on a round-the-clock basis, 365 days a year. The GOES system used for this purpose to date has yielded unsatisfactory results and Hydro-Québec is therefore exploring the possibility now of making maximum use of the IRIG-B system.<sup>2</sup>

This paper presents the results of measurements performed at two points on the Québec utility's power system and describes the measurement and calculation techniques. The operating principles of the slave clock to be used for detection purposes are also described.

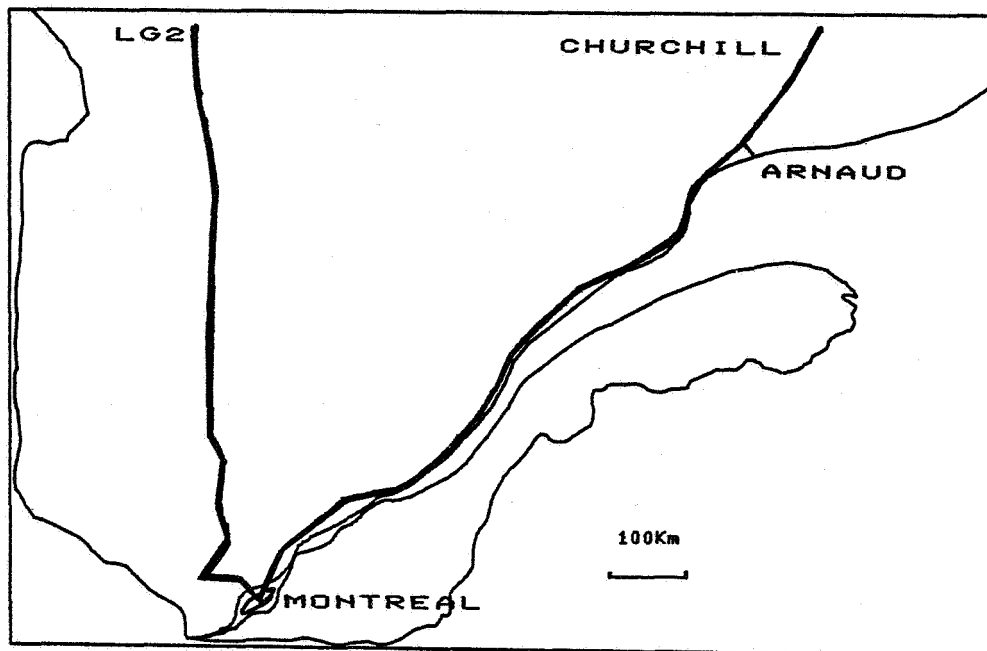

HYDRO-QUEBEC MICROWAVE NETWORK  
SIMPLIFIED DIAGRAM

Figure 1.

## 2. STABILITY MEASUREMENTS

### 2.1 Hydro-Québec microwave system

Hydro-Québec's microwave system, illustrated in Fig. 1, comprises two main branches basically: Montréal-Churchill Falls Via Arnaud substation, and Montréal-LG2. The former, i.e. the Montréal-Churchill-Falls branch is the synchronized type. A pilot is transmitted from Montréal and used at the various substations to phase-lock the local oscillators of the multiplexer. The Montréal-LG2 branch, on the other hand, is the free-oscillator type in which the pilot serves only to generate alarms when the frequency error exceeds a given limit.

In practice, the synchronized system provides a guarantee that the frequency of the multiplexer input and output signals will be identical except in the case of loss of synchronization. Furthermore the phase between the input and output signals increases or decreases stepwise whenever a momentary loss of synchronization occurs.

The nonsynchronized system can introduce a maximum error of 1 Hz in the transmitted signal, which would therefore be 1000 Hz at the input and 1001 Hz at the output. However, in practice, this error is more like 0.1 Hz, which results in a smooth phase drift.

These characteristics of Hydro-Québec's microwave systems mean that a corrector has to be used in order to rebuild a usable IRIG-B signal. Tests were therefore conducted on both types of multiplexer to study their performance. For this purpose we used an IRIG-B code originating in Montréal from a rubidium frequency standard HP 5065-Z. Measurements were made on the IRIG-B code received and corrected at LG-2 and at Arnaud substation.

## 2.2 Test setup

In the test setup at Arnaud Substation (Fig. 2) we used a time code reader and a synchronized generator (Datum 9390). A clock with a quartz oscillator was used while an interval counter and a strip chart recorder served to measure the accumulated line error between the two times scales (IRIG-B and crystal oscillator).

At LG2 (Fig. 3) we used our mobile clock<sup>1</sup> with a rubidium standard as reference (FRKH EFFATOM). This unit comprises the IRIG-B decoder, the corrector and the interval counter together with a separate recorder.

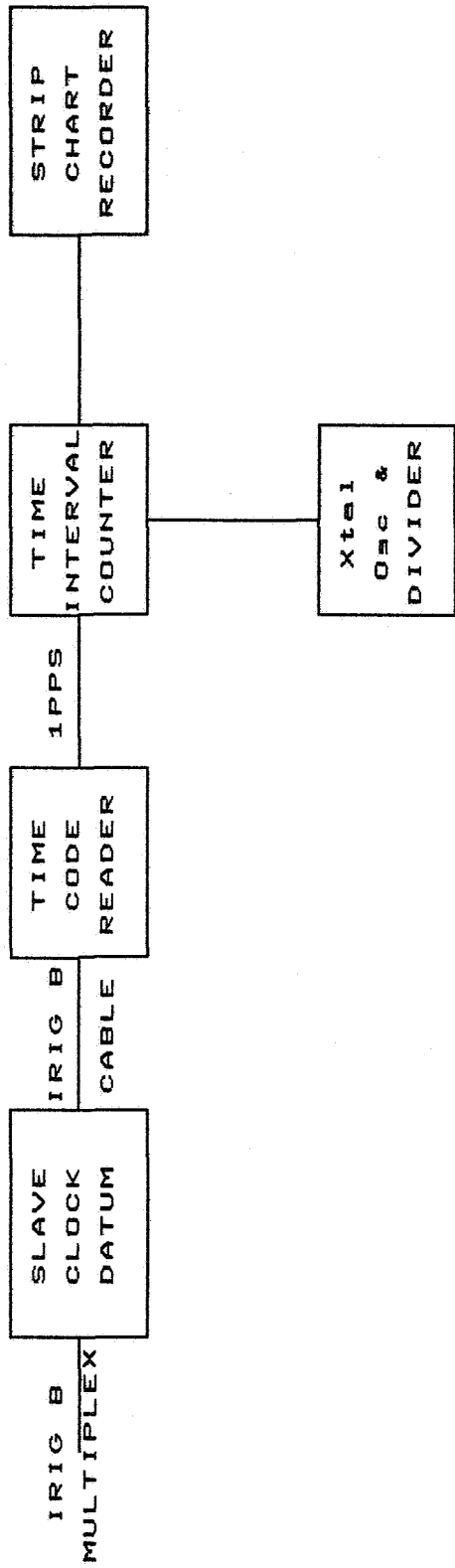

ARNAUD: MEASUREMENT APPARATUS

Figure 2.

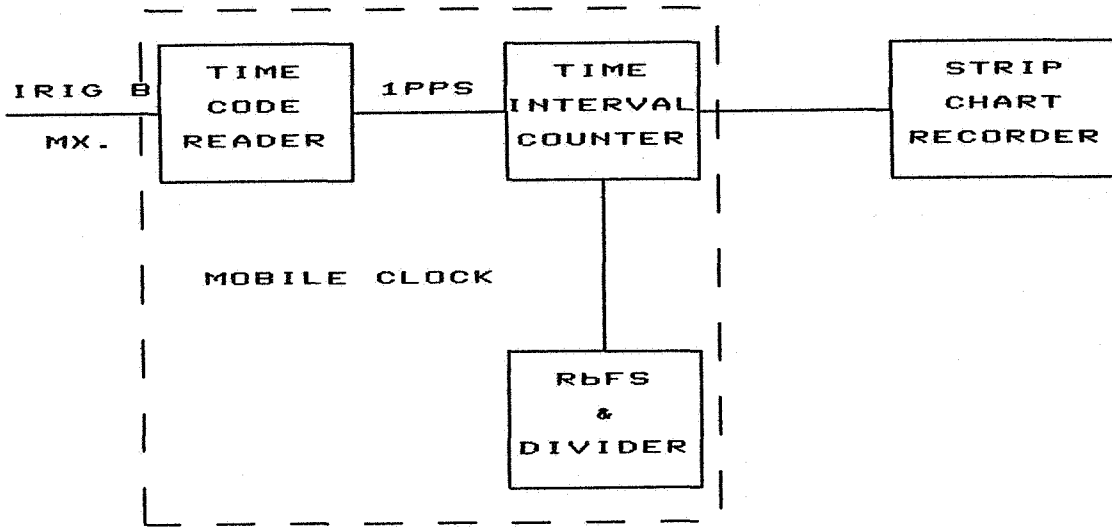

LG2: MEASUREMENT APPARATUS

Figure 3

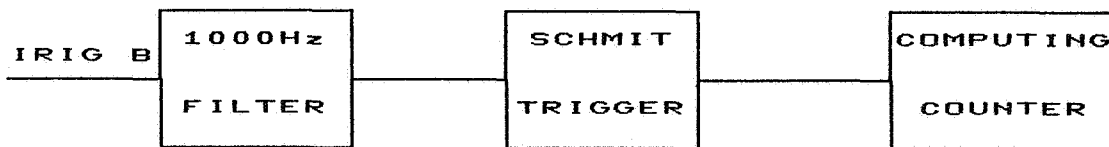

SHORT TERM MEASUREMENT APPARATUS

Figure 4

For the short-term measurements (Fig. 4) a computing counter HP 9360A, a band pass filter (Q=4 at 1000 Hz) and a Schmitt trigger were used.

### 2.3 Experimental results

Typical curves obtained are presented in Fig. 5. Some synchronization losses were observed at Arnaud (Fig. 6). The accumulated time error values obtained were digitized. The following equation<sup>3</sup> served to calculate the frequency stability:

$$\sigma_y(t) = \frac{1}{2T^2} [4U_x(\tau) - (2\tau)]$$

where  $U_x(\tau) = \langle [x(t) - x(t+\tau)]^2 \rangle$

$x(t)$  = variations in the time scale due to random frequency variations.

Two such curves were obtained, one at Arnaud, the other at LG2. The LG2 curve (Fig. 7) shows a long-term stability limit as well as the combined effect of the two rubidium references (master and mobile clocks). This explains the series of points above the typical frequency stability curve of a rubidium frequency standard. The circles indicate the short-term measurements made at IREQ. The curve for Arnaud (Fig. 8) shows the long-term frequency stability limits of the reference clock.

It is clear from these curves that a 10- $\mu$ s transfer time is possible, although this remains to be confirmed by longer-term discrete measurements (over months). In Figs. 9 and 10 we plotted the stability frequency curve in the case of a minor synchronization loss and it can be seen that already the stability has dropped one order of magnitude.

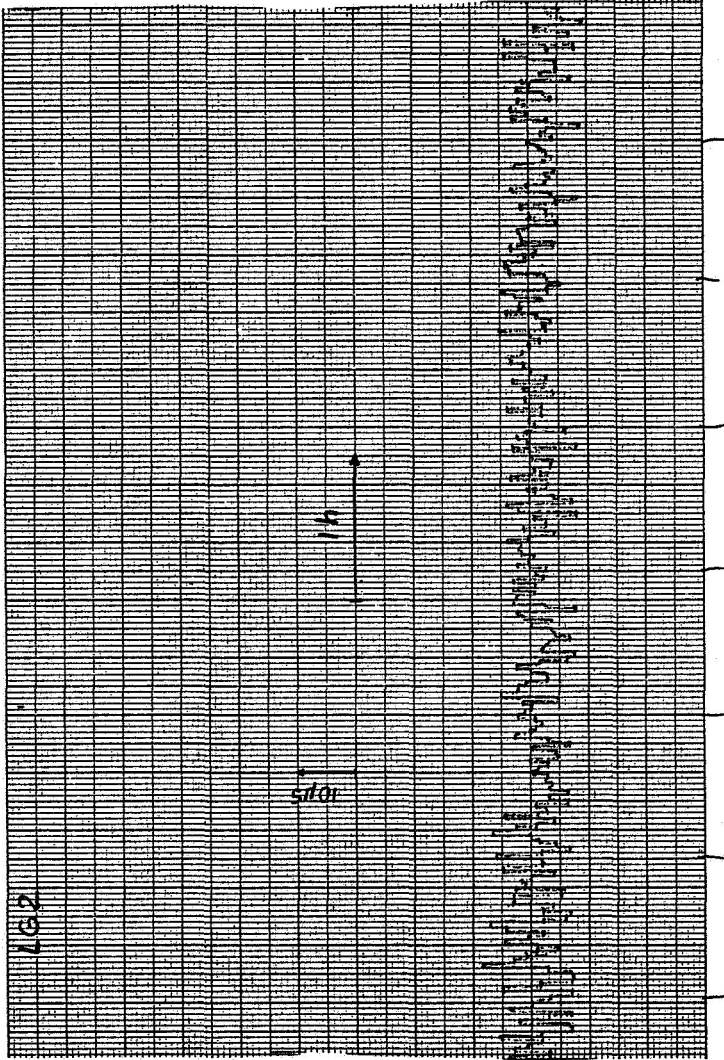

ACCUMULATED TIME ERROR AT LG2

Figure 5

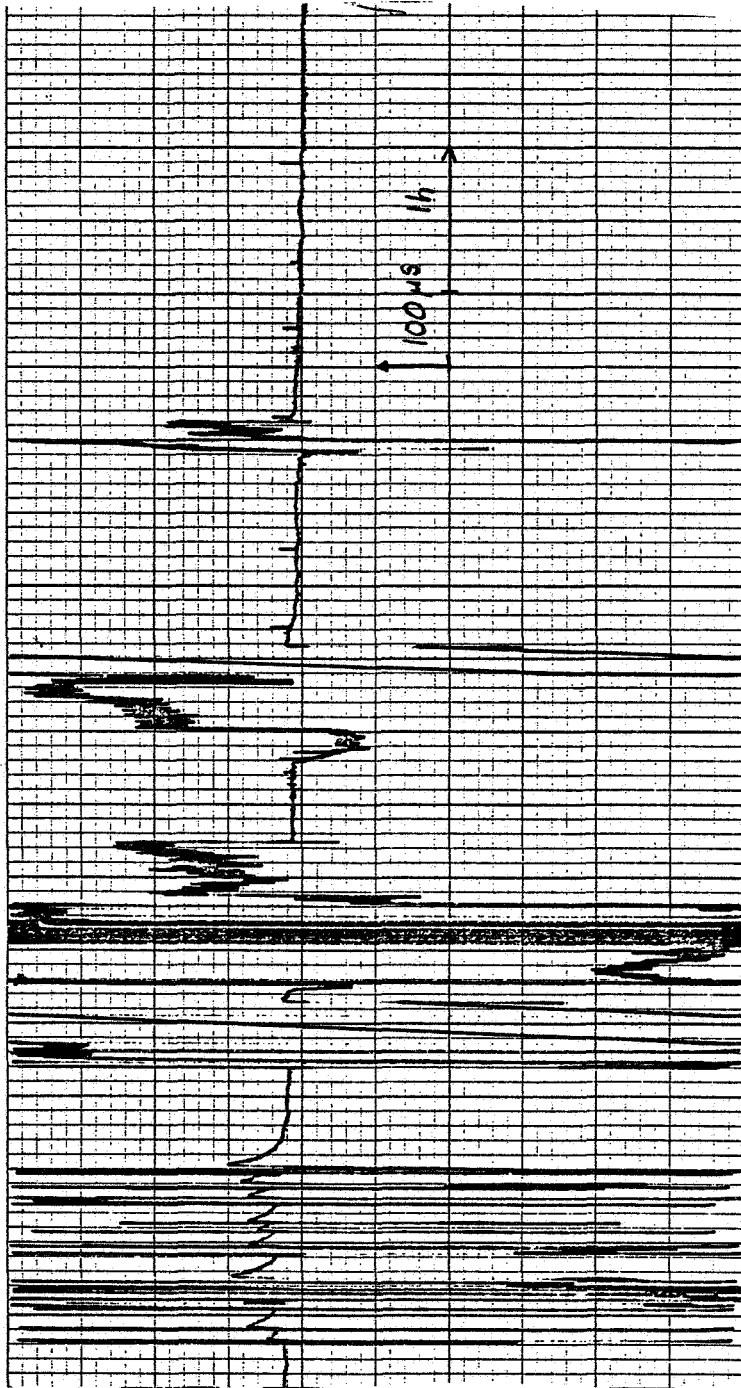

9270-1012

ACCUMULATED TIME ERROR AT ARNAUD  
IN PRESENCE OF NOISE

Figure 6



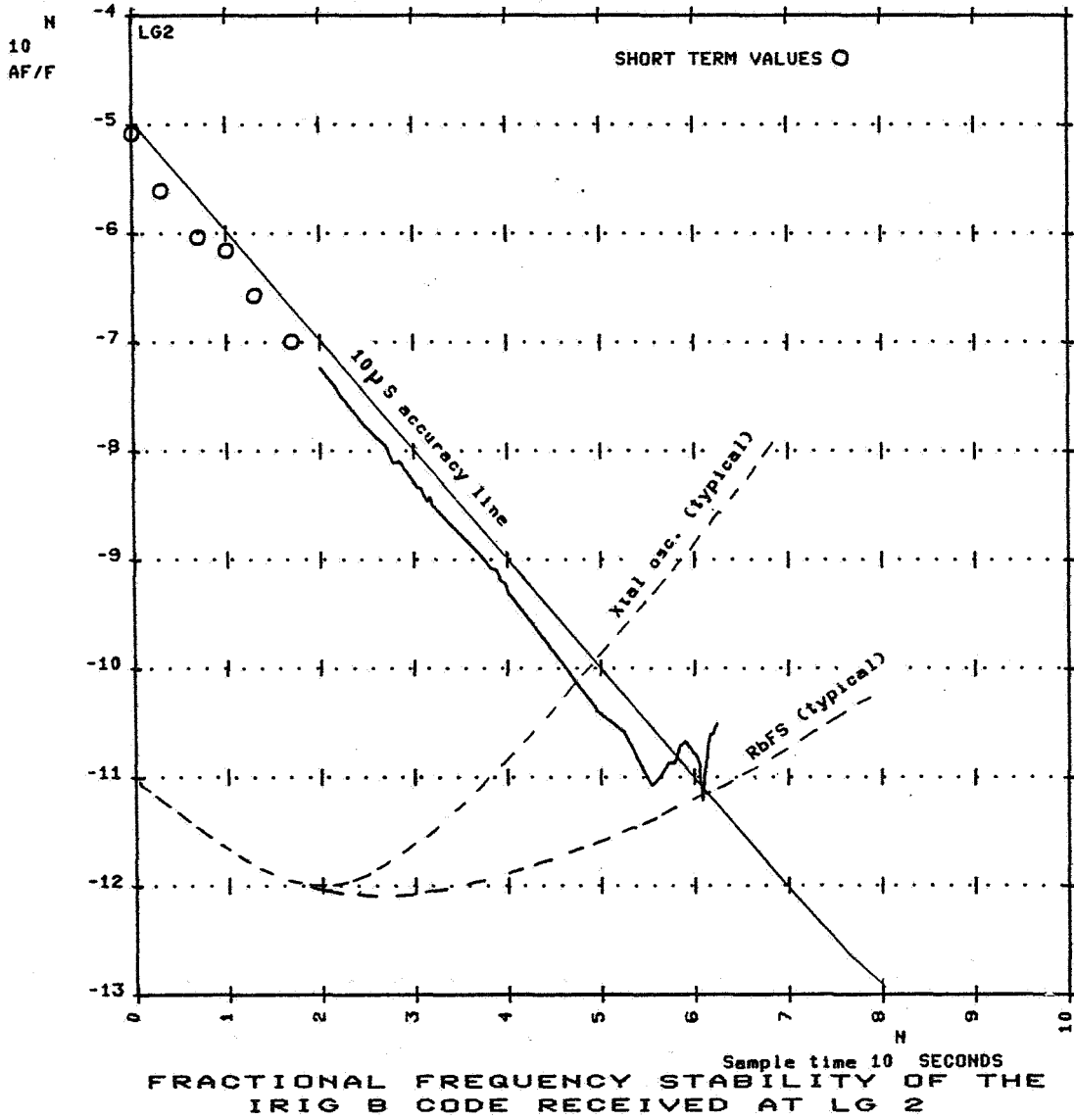

Figure 7

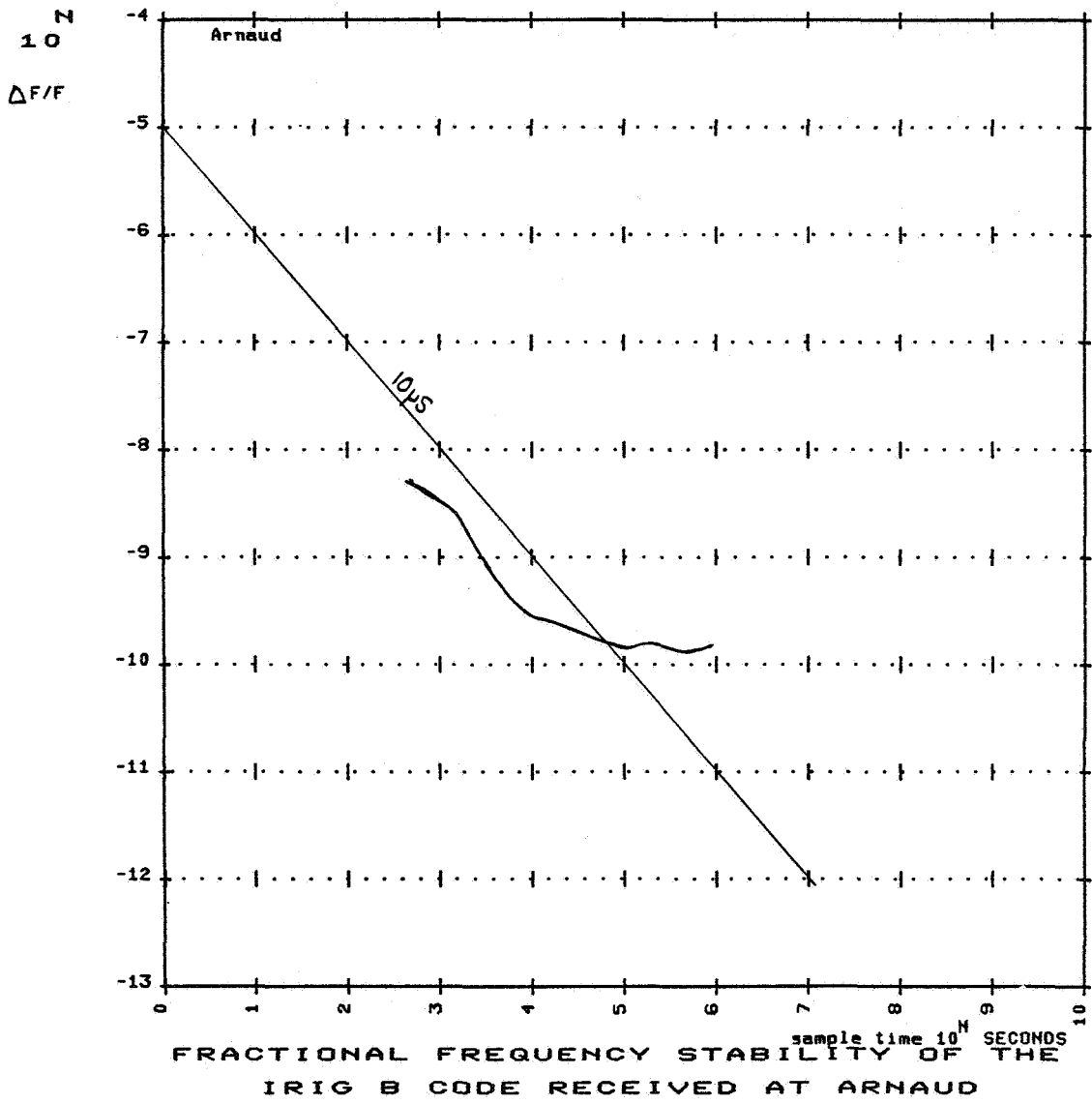
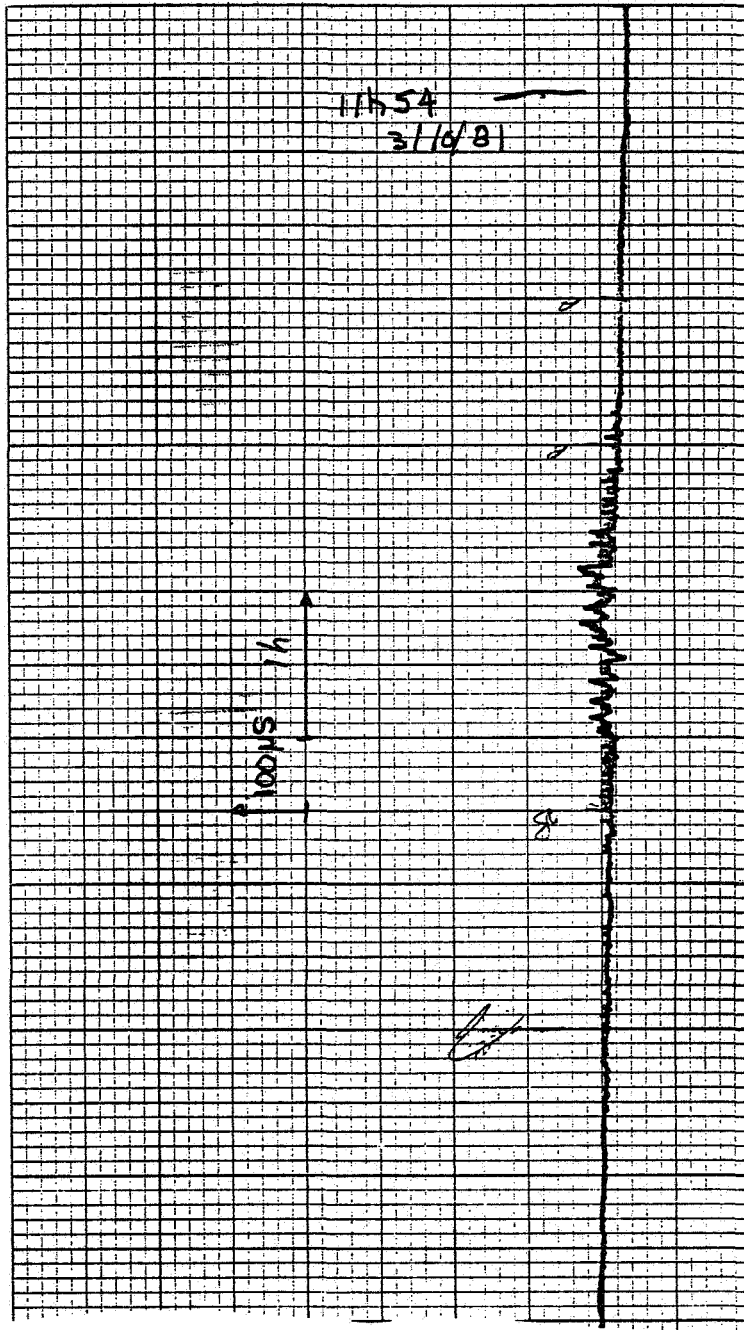

Figure 8.



HEWLETT

ACCUMULATED TIME ERROR AT ARNAUD  
IN PRESENCE OF NOISE

Figure 9

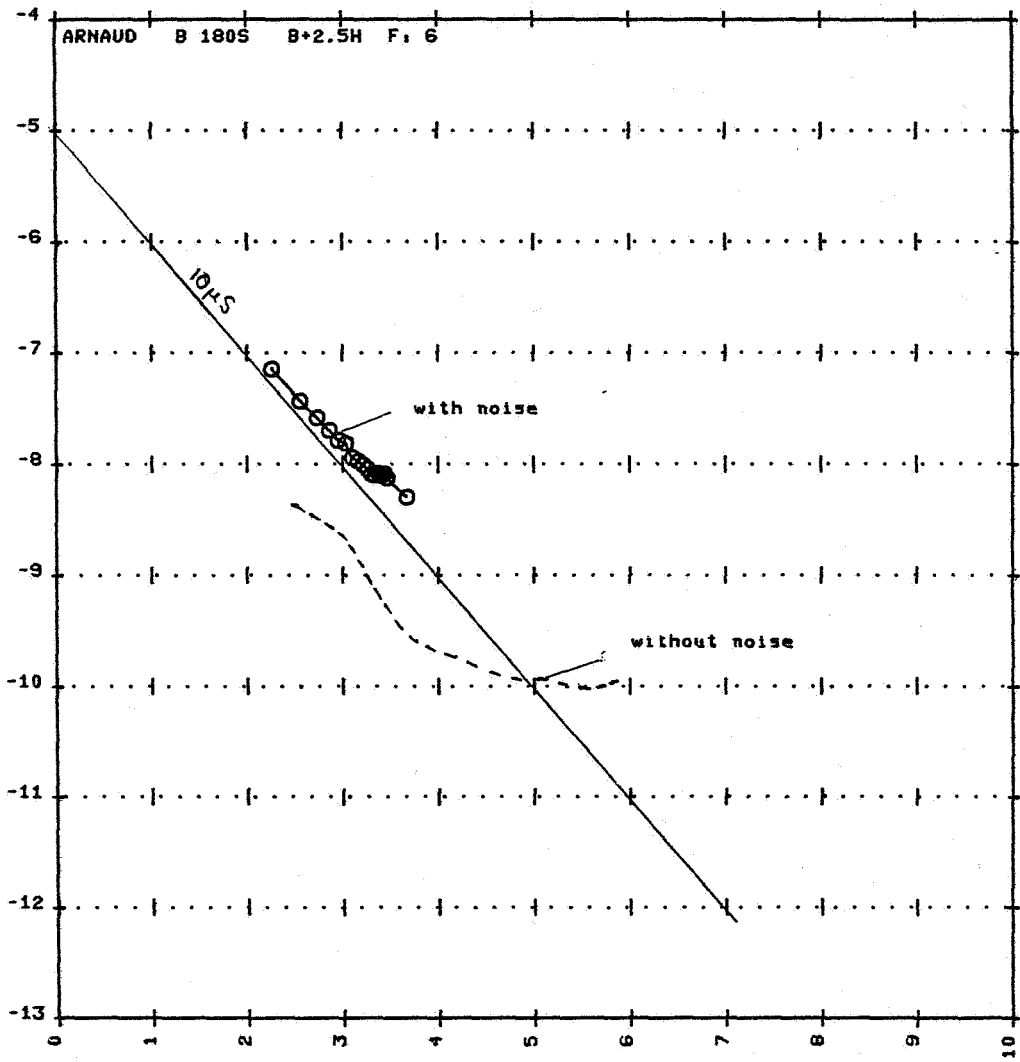

FRACTIONAL FREQUENCY STABILITY OF THE  
 IRIG B CODE RECEIVED AT ARNAUD  
 IN PRESENCE OF NOISE

Figure 10

However, this can be put to good use, as will be explained in the next section.

The curves presented in Figs. 6 and 9 show that a conventional slave clock tracks the input-signal drift with a relatively short time constant ( $\approx 5$  min or less). This is indispensable because the IRIG-B code reader must be sufficiently agile to follow the input signal; otherwise it risks losing the signal and will have to begin sweeping to relocate it. The coupled generator therefore has to follow the reader. We are now in the process of developing a unit in which the reader and the generator are controlled separately by the same microprocessor.

Figure 11 presents a block diagram of the prototype slave clock. The time code reader tracks the input code, eliminating the short-term noise (up to a few tens of seconds). The programmable divider A drives the time code reader.

On the other side we have a separate generator, which is corrected with another programmable counter B, and a unit for measuring the time difference between the reader and the generator.

This approach enables us to maintain a relatively short time constant (a few tens of seconds) for the reader, and consequently keep a check on any code drift while checking its consistency, without needing to shift the generator in time. The generator can in fact be corrected with a time constant of between a few hours and over one day if we use a rubidium standard.

Furthermore we can make note of corrections to the divider B so that we have an idea of the drift of the frequency standard, which can be systematically corrected whenever the input signal disappears. In this case we have a zero offset frequency equivalent at the outset. If

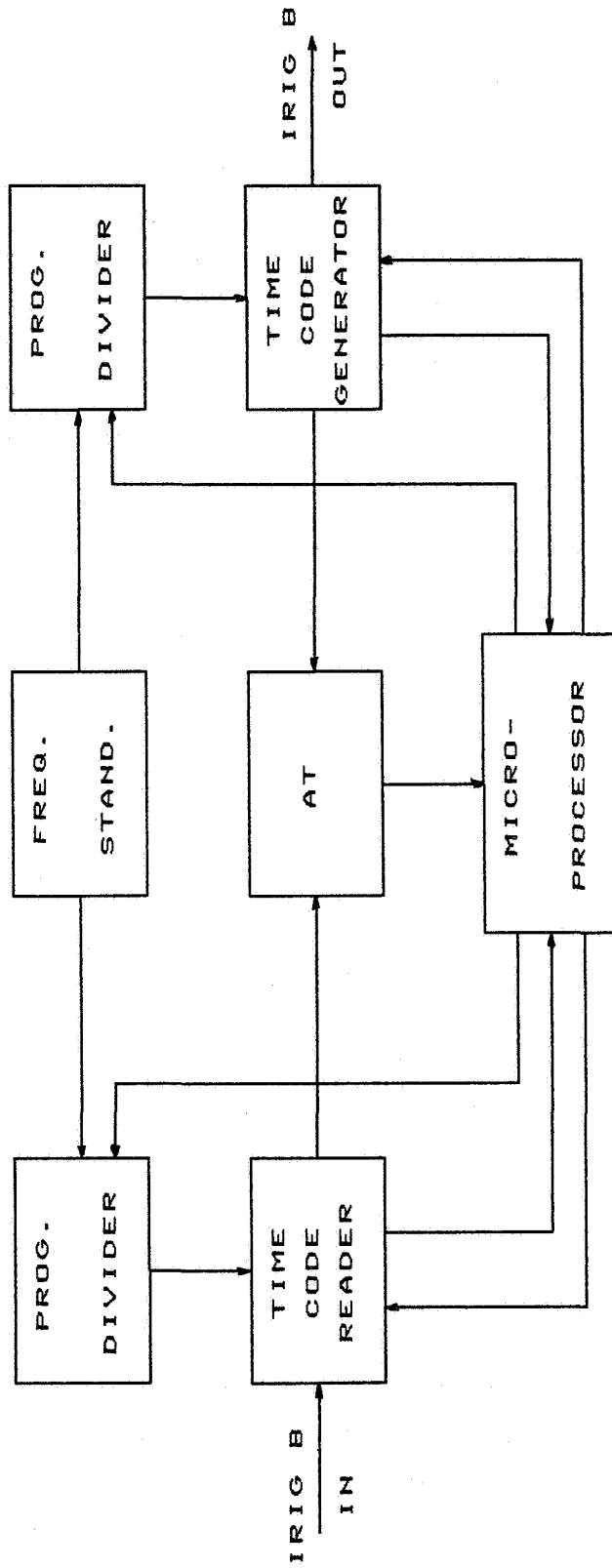

SLAVE CLOCK BLOCK DIAGRAM

Figure 11

a rubidium frequency standard is used, the corrections can be transmitted, thus providing an excellent means of remotely studying the clock performance without having to add an outside reference clock.

Furthermore, the  $\Delta T$  interval counter allows us to calculate the stability of the IRIG-B code as received and read, thus providing a reliable means of knowing whether or not we are in the presence of noise so as to ignore the input in the generator correction process. This approach is far more sensitive than the method presently employed, which consists in checking whether or not the input signal is present. A photograph of the prototype clock is shown in Fig. 12.

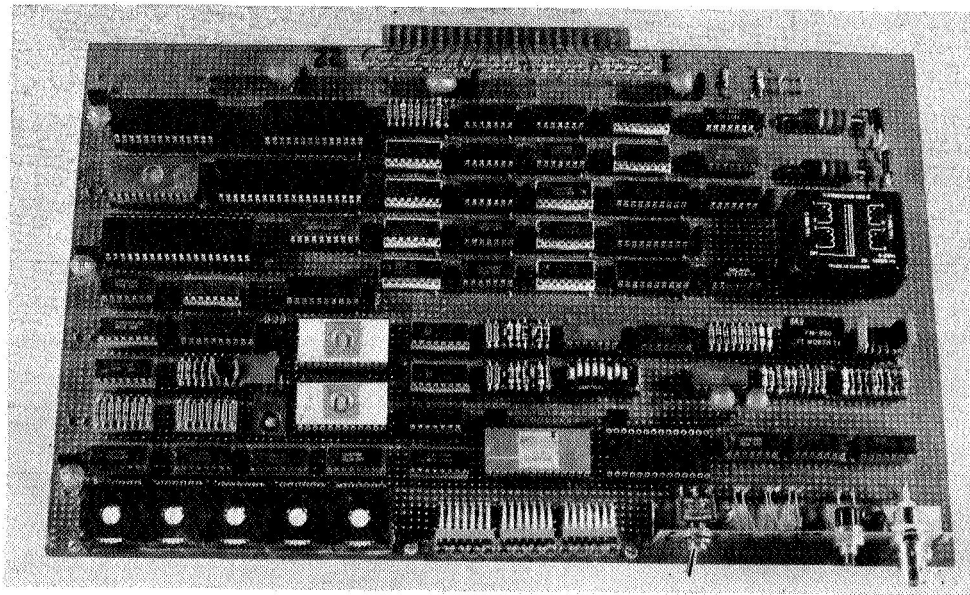

SLAVE CLOCK PROTOTYPE

Figure 12

## CONCLUSION

In this paper we have examined the stability of a time code disseminated on a microwave system. The measurements obtained reveal a possibility of time transfer with an accuracy of 10  $\mu$ s. The new prototype slave clock used should allow us to give a reliable time code despite interference in the microwave network by calculating the frequency stability of the signal received. This unit will also allow remote transmission of corrections to the generator and thus provides a possible means of control and measurement.

## REFERENCES

- (1) PTTI Application at Hydro-Québec, G. Missout, J. Béland, G. Bédard, p. 377-385, 12th PTTI, 1980.
- (2) Time Dissemination in the Hydro-Québec Network, G. Missout, W. Lefrançois, L. Laroche, p.343, 11th PTTI, 1979.
- (3) The NBS Atomic Time Scale: Generation, Stability, Accuracy and Accessibility, D. Allan, J. Gray, H. Machlam, NBS Monograph 140, Chap. 9, p.210.