

LOW NOISE BUFFER AMPLIFIERS AND BUFFERED PHASE
COMPARATORS FOR PRECISE TIME AND FREQUENCY
MEASUREMENT AND DISTRIBUTION

R.A. Eichinger, P. Dachel, W.H. Miller and J.S. Ingold
Bendix Field Engineering Corporation
Columbia, Maryland

ABSTRACT

Extremely low noise, high performance, wideband buffer amplifiers and buffered phase comparators have been developed for the NASA Goddard Space Flight Center Atomic Hydrogen Standards Program. These buffer amplifiers are designed to distribute reference frequencies from 30 KHz to 45 MHz from a hydrogen maser without degrading the hydrogen maser's performance. The buffered phase comparators are designed to intercompare the phase of state-of-the-art hydrogen masers without adding any significant measurement system noise. These devices have a 27 femtosecond phase stability floor and are stable to better than one picosecond for long periods of time. Their temperature coefficient is less than one picosecond per degree C, and they have shown virtually no voltage coefficients. When used in distribution amplifiers and phase comparison systems, these devices have greater than 90 dB of isolation.

INTRODUCTION

Extremely low noise buffer amplifiers, distribution amplifiers and buffered phase comparators have been developed by NASA Goddard Space Flight Center's Atomic Hydrogen Standards Program with engineering support from Bendix Field Engineering Corporation (BFEC). The buffer amplifiers are designed to distribute reference frequencies between 30 KHz and 45 MHz without degrading the hydrogen maser's performance. The distribution amplifiers are designed to provide multiple outputs with a minimum of cross talk. The phase comparators are designed to intercompare the phases of state-of-the-art hydrogen masers without adding any significant system noise.

BFEC has been building, testing and improving these buffer amplifiers and phase comparators. Both the electrical and the mechanical designs ensure their meeting the requirements of hydrogen maser performance.

These devices have been extensively tested. This paper will report on the results of those tests and the specialized test systems developed to perform these tests.

The contents of this paper have been divided into five sections. The first section will state what is meant by distribution and measurement requirements that do not degrade state-of-the-art performance of hydrogen masers. In the second section, an electrical and mechanical description of buffer amplifier and phase comparator design will point out the reasons for their high stability. The third section will describe the tests and measurements performed and will discuss in detail the systems used to perform those tests. Fourth, a detailed test result section will discuss the results of each test and discuss some design improvements that have increased performance. A final section will summarize the data for easy reference.

The tests and measurements are divided into three groups.

1. TIME DOMAIN PHASE TESTS
 - a. Temperature Coefficient
 - b. Power Supply Voltage Coefficient
 - c. Mechanical Shock Coefficient
 - d. Allan Variance Phase Stability
2. FREQUENCY DOMAIN TESTS AND MEASUREMENTS
 - a. Frequency Response
 - b. Harmonic Signal Generation
 - c. VSWR
 - d. Isolation (back-to-front, port-to-port)
3. SPECTRAL PHASE MEASUREMENTS
 - a. Phase Noise Spectrum
 - b. 60 Hz AC Magnetic Field Sensitivity

Time domain phase tests were run to test for phase changes due to environmental changes. The tests that were run include tests for temperature coefficient of phase, voltage coefficient of phase, mechanical shock coefficient of phase and Allan variance tests for phase

stability. Frequency domain tests and measurements are also included. Wideband frequency response, harmonic signal generation, and VSWR were measured. The buffer amplifiers and phase comparators were also tested for back-to-front isolation. When the buffer amplifiers were configured with a power splitter to form a distribution amplifier, port-to-port isolation tests were run. Spectral phase measurements were made of phase noise in a 10 Hz BW between DC and 1 KHz, and phase noise in a 100 Hz BW between DC and 100 KHz. The same measurement system was also used to test for 60 Hz AC magnetic field sensitivity.

REQUIREMENTS.

Hydrogen masers have phase stability floors of the order of 0.1 ps and long term stabilities of the order of 1 ps (1). In order not to degrade these stable signals, distribution and measurement devices must have extremely low additive noise, high stability and low sensitivity to environmental changes. Also, to minimize the effect of cross talk from multiple users, isolation factors from -110 dB to -90 dB are required at 5 MHz.

For this paper, except when talking about isolation, phase disturbances will be normalized to clock error units by:

$$x = \frac{\phi}{\omega_0}$$

but, for simplicity, will still be referred to as phase changes or phase stabilities. A phase error of 1 ps on a 5 MHz carrier corresponds to an isolation of -90 dB and 0.1 ps at 5 MHz corresponds to -110 dB. Small phase changes, $\delta\phi$, may be converted to units of dB by the relation:

$$\delta\phi = 20 \log \delta x + 20 \log \omega_0$$

where δx is a small time disturbance in seconds and ω_0 is the carrier frequency in radians per second.

The buffer amplifier and phase comparator devices described in this paper exceed the minimum requirements of hydrogen maser performance. As testing continues, the major contributors to phase errors are being isolated and improved upon by design modifications. A brief electrical and mechanical description follows.

DESCRIPTION OF DEVICES

The buffer amplifier was designed for use in 50 Ω RF systems. The gain can be adjusted from 0 to 10 dB to bring outputs up to 1 VRMS to compensate for the power splitter losses of distribution systems. Each buffer amplifier has its own voltage regulator to reduce indirect cross talk due to power supply changes under varying load conditions.

The essence of the buffer amplifier is in its high stability and high isolation. This is achieved not only by its electronic design (2) but by its mechanical design. A common heat sink for all semiconductor circuit elements has been essential in producing good temperature performance. The heat sink slows down the effects of ambient temperature changes and reduces gradients across semiconductor components improving the cancellation of temperature effects inherent in matched semiconductor components.

The phase comparator is used to compare the phases of two RF signals at nearly the same frequency with subpicosecond precision. The two RF signal inputs are highly isolated by buffering each port with a unity-gain buffer amplifier (see figure 1). These drive a double balanced mixer generating a beat frequency between the two RF inputs. The beat frequency is filtered by a passive low pass filter and then by an active low-passed, zero-crossing detector. A TTL compatible square wave is output with positive and negative going edges corresponding to the zero-crossings of the beat between the two RF signal inputs. If the epoch of these TTL edges is measured by a clock, the phase difference between the RF inputs can be constructed.

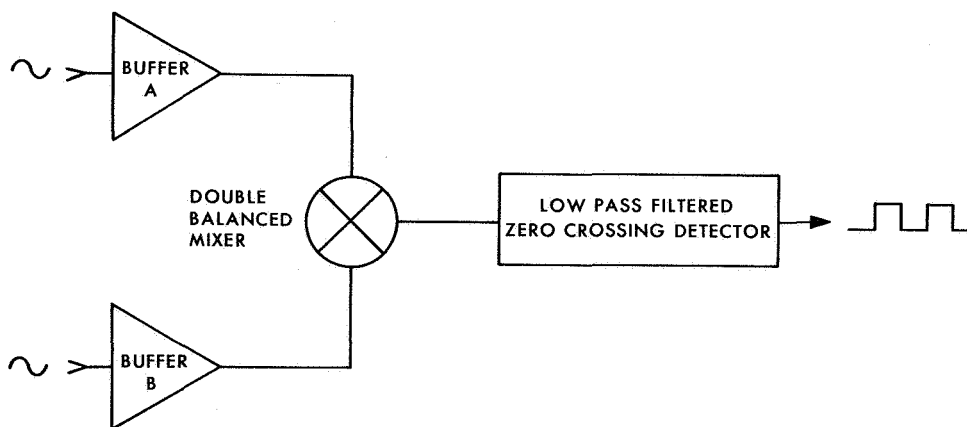

Figure 1. Buffered Phase Comparator Block Diagram

The phase comparator employs the same mechanical design as the buffer amplifier. A common heat sink is used for all the semiconductors in its two buffer amplifiers and double balanced mixer. Reducing temperature gradients across the double balanced mixer is especially important since it achieves its high stability by using four matched diodes.

DESCRIPTION OF TEST SYSTEMS

Time Domain Phase Tests

Many of the tests are run using a dual phase comparator test system (see figure 2). The test technique is based on the Picosecond Time Difference Measurement System used by the National Bureau of Standards (NBS) (3). Two TTL signals corresponding to the same phase difference between two crystal oscillators are intercompared by a time interval counter. To improve the system's phase stability floor, the RF cables are adjusted to cancel the phase noise from the crystal oscillators.

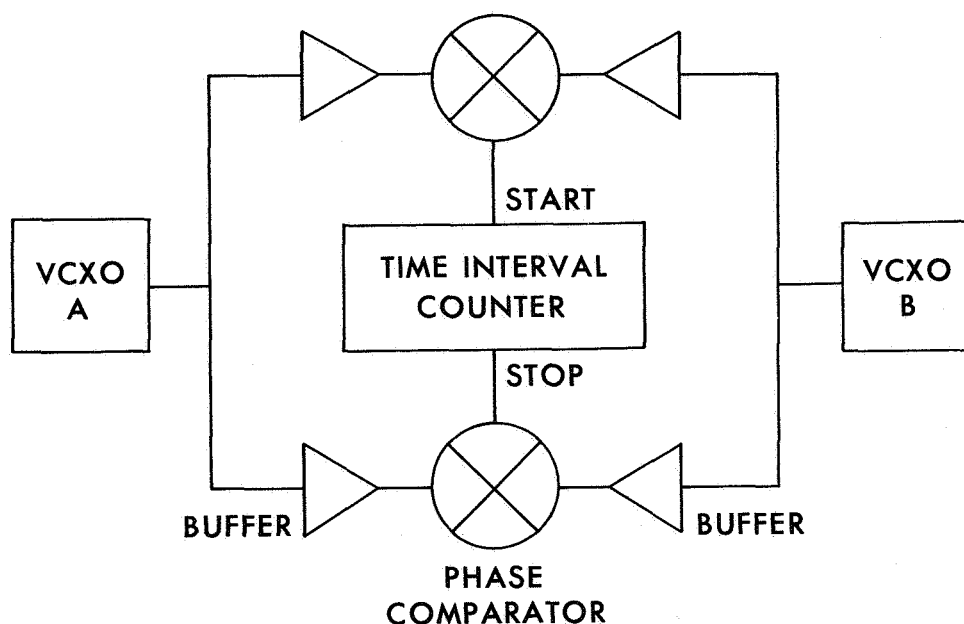

Figure 2. Dual Phase Comparator Test System

The dual phase comparator test system is a versatile test instrument. Once a test set-up has been characterized, test devices are substituted for known good devices. Device phase change characteristics versus time, temperature, power supply voltage, mechanical shock and 60 Hz AC magnetic fields are calculated from phase data.

The tests are automated by a programmable calculator. Most tests have operating programs that control programmable time interval counters, digital multimeters and digital plotters. Software has been written for the HP9815 and HP9825 calculators to run plots on two types of HP

plotters. Each of the programs allow the operator to select plotting scales and the number of data points to be averaged. A program to run two sample allan variance data may be run at any time during the tests.

Frequency Domain Tests and Measurements

Frequency domain tests and measurements were made with a tracking generator and a spectrum analyzer (see figure 3). The type of analyzer varied, depending on the frequency band of the measurement.

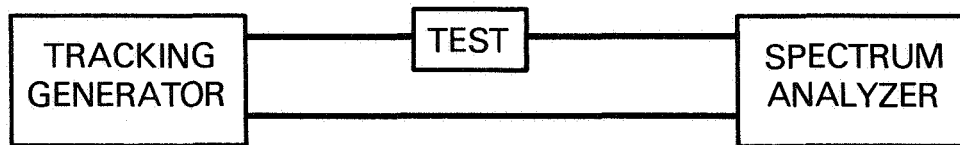

Figure 3. Frequency Domain Test and Measurement System

The buffer amplifiers and phase comparators are tested for back-to-front and port-to-port isolation. The test is performed simply by inputting a nominal signal (+13 dBm) into the output and examining the leakage signal at the input. Another method used in multiple buffer amplifiers systems is to short or open the output of one buffer while recording the phase of a signal through another buffer with the dual phase comparator system (see figure 2). Each test reveals a worst case phase disturbance as previously discussed.

Tests for harmonic distortion are made on all buffer amplifiers and phase comparators. The signal level of both the second and third harmonics are recorded relative to a +13 dBm output signal at 5 MHz. Although harmonic signals, which are phase coherent, pose no phase problem; they are of interest to those who use these devices with frequency multiplication or division circuits.

A similar configuration with a programmable network analyzer replacing the spectrum analyzer was used to measure voltage standing wave ratio (VSWR). The VSWR was run to ensure an accurate 50 Ω input and output impedance over the entire bandpass of the buffer.

Spectral Phase Measurements

Spectral phase measurements were made using a single mixer test system (see figure 4). A 5 MHz signal is split and shifted 90 degrees by a quadrature hybrid phase shifter (4). The unshifted signal is fed through a buffer amplifier and input to one port of the mixer. The shifted signal is fed through a variable air line and another buffer to provide signals 90 degrees different in phase at the mixer. The mixer symbol, in figure 4, represents a modified phase comparator; in which, both the active filter and zero-crossing detector were bypassed. To minimize high frequency noise, a two-pole, low pass filter was used following the mixer. One stage was placed at the output of the mixer and the other stage was placed at the input of a low frequency spectrum analyzer.

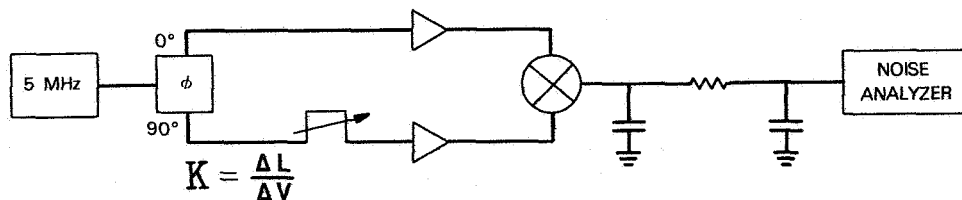

Figure 4. Spectral Phase Measurement System

The basic theory of this measurement technique is as follows. The mixer outputs a voltage that is proportional to small phase changes:

$$\phi \propto V$$

thus small changes in phase can be measured in terms of small changes in voltage. Phase disturbances may be written as:

$$\delta\phi = \frac{K\omega_0}{c} \delta V$$

where K is a calibration constant in centimeters per volt, made by increasing the path of one signal through the variable air line and recording the DC voltage change with a precision digital multimeter. The constants, ω_0 and c, are included to convert K to radians per volt. Small voltage disturbances are generally measured in dBV and can be converted to phase disturbances in dB by:

$$\delta\phi = \delta V + 20 \log \frac{K\omega_0}{c}$$

To measure the phase noise spectrum of one or more unity-gain buffers, they may be substituted for other buffers or added to either signal path. Then the additional phase noise is displayed on the spectrum analyzer. The test system was checked for flat, low frequency response by frequency modulating a small signal on one 5 MHz signal. The system's frequency response rolled off 3 dB at 900 KHz.

The test system was used to measure the phase spectrum in a 10 Hz bandwidth (BW) between DC and 1 KHz and the phase spectrum in a 100 Hz BW between DC and 100 KHz because a 1 Hz BW spectrum analyzer was not available at the time. The data were not corrected to a 1 Hz BW because the correction factor would be different for the phase noise spectrum and the spectral lines in the data. Another measurement made with this system was the 60 Hz AC magnetic field sensitivity of the buffer amplifiers, distribution amplifiers and phase comparators. An AC field was generated by using a spare maser field coil. The test device was oriented in its most sensitive position so that a worst case 60 Hz phase noise peak could be recorded.

TEST RESULTS

The previous section outlined the tests that have been run on buffer amplifiers, distribution amplifiers and phase comparators. This section will discuss raw data samples of typical test results. Also discussed, will be changes to the buffer amplifier and phase comparator design that were made to improve certain test results.

Figure 5 is a plot of phase comparator temperature performance. The plot of phase in picoseconds as measured by the dual phase comparator test system is shown. The temperature of the phase comparator under test is monitored on the chassis. Upon completion of the test, a temperature coefficient is then calculated from the phase change before and after the temperature step. Phase comparator test results are all better than 1.0 ps/°C. Please note the peak-to-peak phase noise on figure 5 and compare it with figure 6.

Figure 6 is a plot of buffer amplifier temperature performance. The peak-to-peak phase noise is noticeably higher. This increase in noise level was purposely caused by delaying one signal path so that the phase noise of the crystal oscillators could not be sufficiently cancelled. Time delays are normally held below 1 ns to ensure a 27 femto-second noise floor. A thirty-eight buffer sample was tested by this method. Their mean temperature coefficient was 0.41 ps/°C with a standard deviation of 0.27 ps.

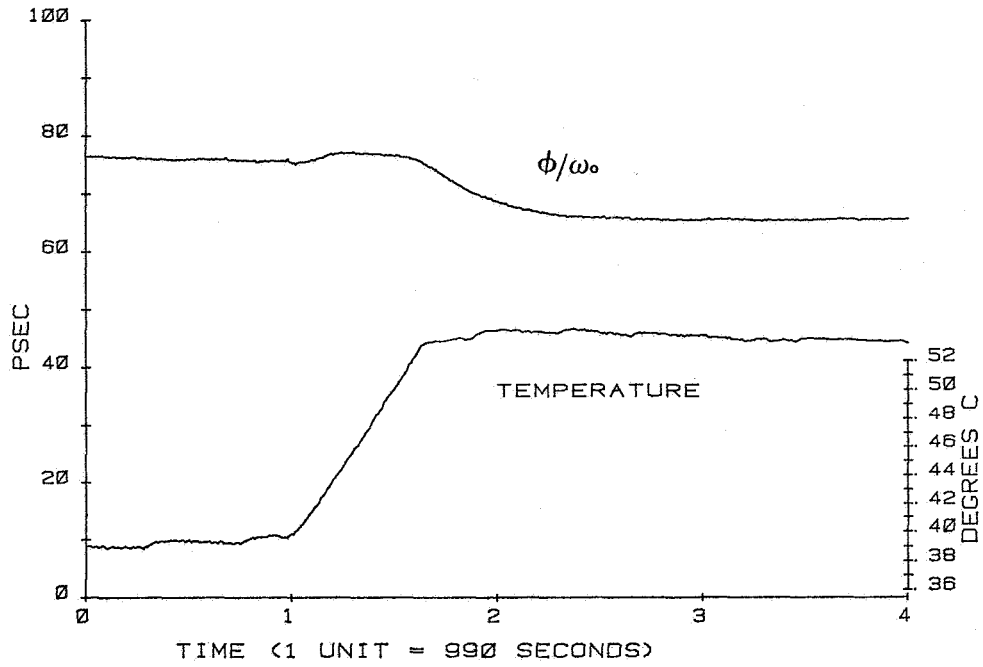

Figure 5. Typical Phase Comparator Temperature versus Phase Performance

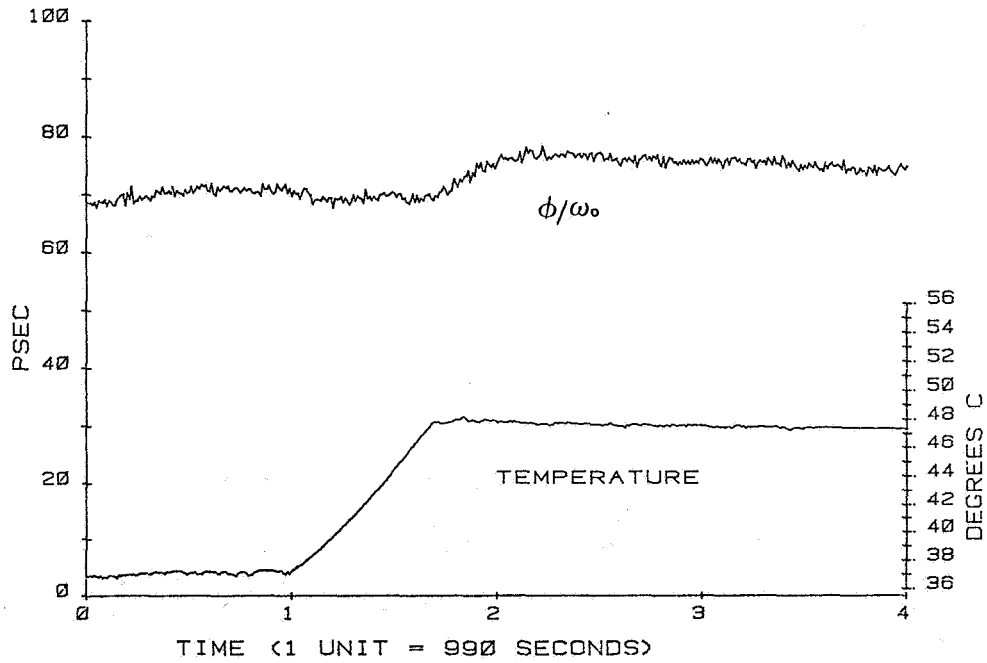

Figure 6. Typical Buffer Amplifier Temperature versus Phase Performance

Shock sensitivity was also tested for using the same dual phase comparator test system. A calibrated hammer blow was applied to several buffers' most sensitive chassis face. When it was discovered that small movements in the position of parts in the buffer amplifier caused relatively large phase jumps, a thermal conductive potting compound was used to reduce the phase jumps to less than 1 ps/10 g shock (see figure 7). One ps is the dual phase comparator system resolution since any band in the RF cables caused a 1 ps phase jump.

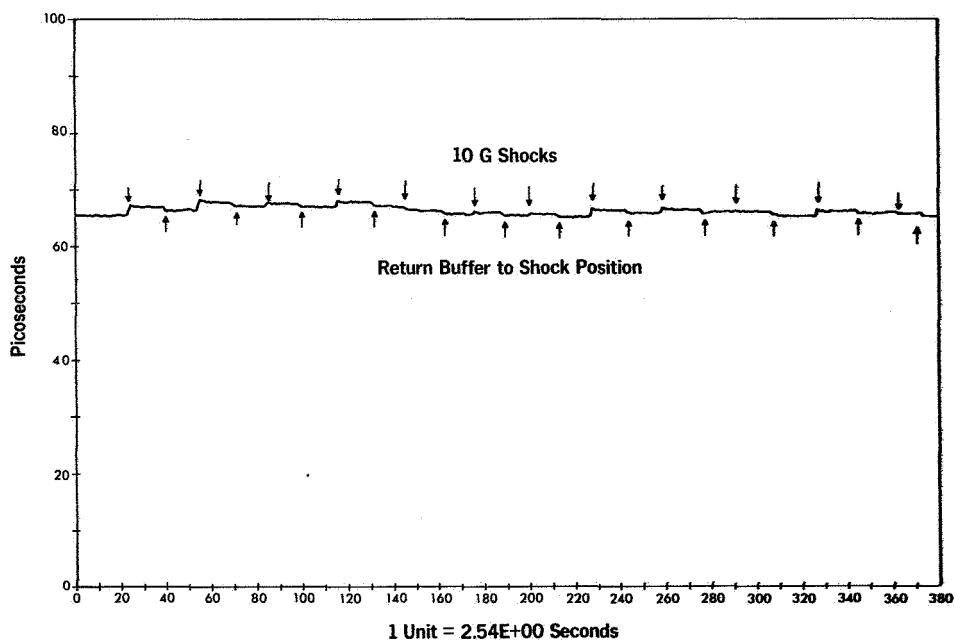

Figure 7. Typical Buffer Amplifier Mechanical Shock versus Phase Performance

Figure 8 is a plot of power supply voltage versus phase for a buffer amplifier. The power supply voltage was stepped from 25 to 32 volts. There were no phase changes, to the resolution of the measurement system, between 26 and 32 volts. Below 26 volts the buffer amplifier's voltage regulator does not work since a 2.7 volt drop must be maintained across the regulator.

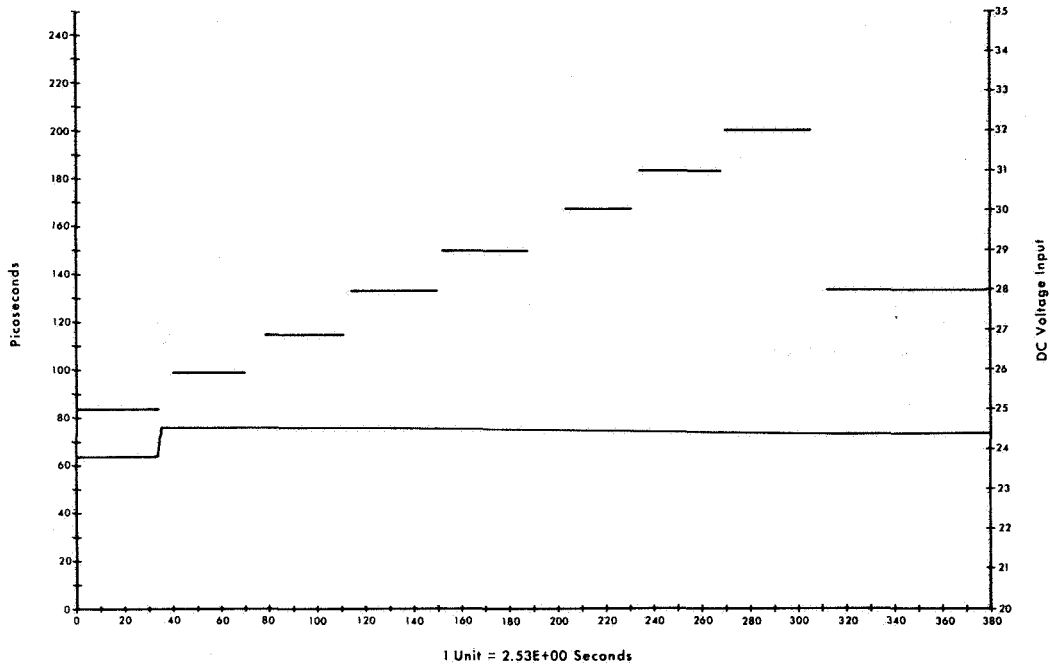

Figure 8. Typical Buffer Amplifier Power Supply Voltage versus Phase Performance

Sixty Hz AC magnetic field sensitivity can be tested for using the dual phase comparator system but the spectral phase test system has higher resolution. A 60 Hz response and corresponding odd harmonics are displayed on a spectrum analyzer. The spectrum analyzer has a few of its own 60 Hz peaks as shown in figure 9. The high peak at 0 Hz is also an intrinsic property of the spectrum analyzer. When a phase comparator was tested for 60 Hz magnetic field sensitivity in a 10 gauss field, the 60 Hz peak was -90 dB. The mixer calibration factor of $20 \log K_{\omega_0/c}$ was +6 dB. This magnetic susceptibility, although tolerable, can be reduced to -120 dB by lining the phase comparator with a 0.005 in. sheet of co-netic foil.

Figure 9 also shows the phase noise spectrum of the phase comparator's output signal. The 6 dB mixer calibration correction is included in this data. The extremely good noise performance of the phase comparator is clearly shown in figure 9. Since both the 180 Hz and 300 Hz peaks are analyzer generated, the phase noise level in a 10 Hz BW between DC and 1 KHz is less than -138 dB.

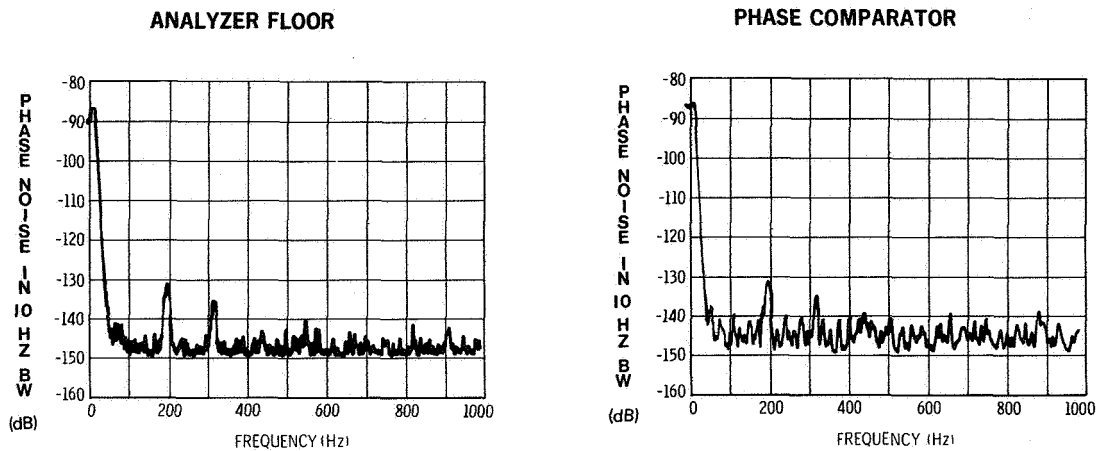

Figure 9. Phase Noise Spectrum of Spectrum Analyzer and Phase Comparator

Buffer amplifiers also have extremely low noise performance. In fact there were two buffers already in the test system during the phase comparator phase noise measurement. Figure 10 shows the phase noise level roughly doubled (+3 dB) when two more buffers were added to the test system. The increase indicates that the measurement system is actually resolving buffer amplifier phase noise.

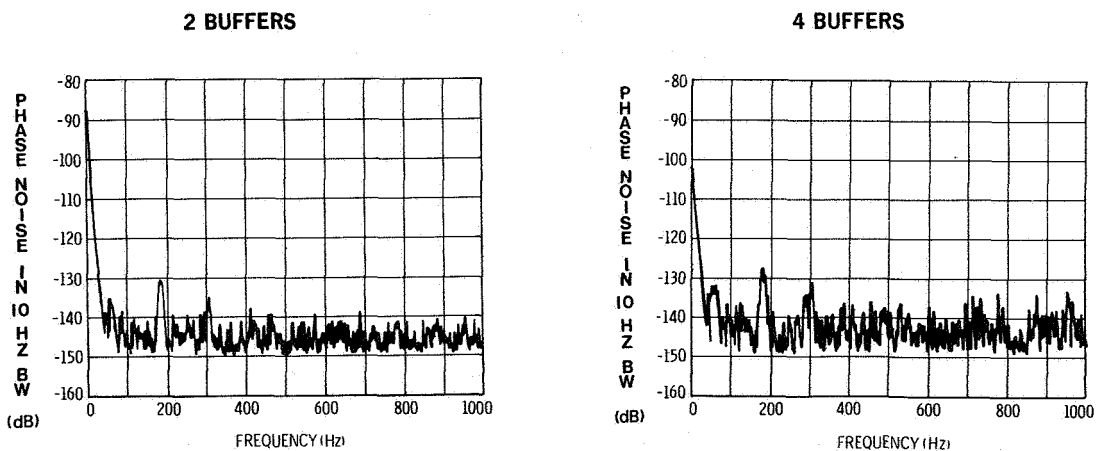

Figure 10. Phase Noise Spectrum of 2 and 4 Buffer Amplifier Measurement Systems

Figure 11 is another comparison of two and four buffer test results. But, these data are of phase noise in a 100 Hz BW between DC and 100 KHz. Again, the noise level increased 3 dB with more buffers. However, whether two or four buffer amplifiers are used, the phase noise level remains well below the required level of -110 dB.

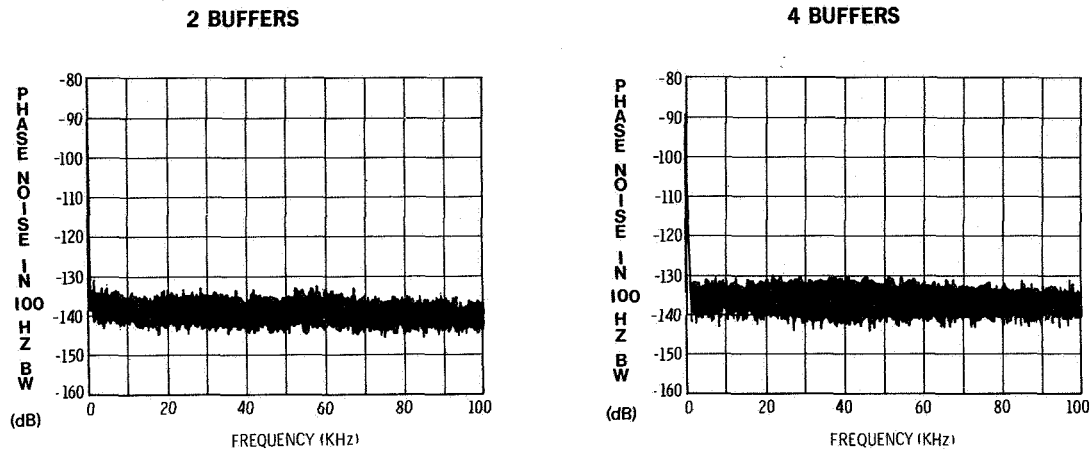

Figure 11. Phase Noise Spectrum of 2 and 4 Buffer Amplifier Measurement Systems

Table 1 shows the port-to-port isolation obtained from a distribution amplifier built for a NASA hydrogen maser. The distribution amplifier uses a Mini-Circuits Lab 8-way power splitter to distribute 5 MHz reference signals to eight output ports. The power splitter design limits the port-to-port isolation between ports on the same side of the power splitter to 25 dB. This causes a quadrant grouping of good and better isolation factors (see table 1).

Summary of Test Results

To summarize all the test and measurement results to date, a buffer amplifier data sheet is provided in table 2. The phase stability in a 12 Hz bandwidth of 27 femtoseconds for 1 second averaging times is a two sample Allan deviate statistic (1).

The temperature coefficient is less than 1.0 ps/°C. The power supply voltage coefficient is less than 0.1 ps/volt which is the dual phase comparator system resolution. Permanent phase jumps from mechanical shocks of 10 G force are less than 1 ps. The 60 Hz AC magnetic field sensitivity, with the buffer turned to its most sensitive position,

		OUTPUT							
		1	2	3	4	5	6	7	8
INPUT	1	X	96	96	96	110	110	110	110
	2	95	X	93	93	110	110	110	110
	3	93	94	X	110	110	110	110	110
	4	93	93	100	X	110	110	110	110
	5	110	110	110	110	X	96	93	93
	6	110	110	110	110	110	X	94	96
	7	110	110	110	110	94	95	X	99
	8	110	110	110	110	95	95	100	X

ALL UNITS ARE IN dB

Table 1. A Typical Distribution Amplifier's Port-to-port Isolation

is -129 dB in a 10 gauss field. Buffer amplifiers configured in a distribution amplifier have a -125 dB sensitivity. Isolation tests at 5 MHz result in a minimum 67 dB back-to-front isolation for a single buffer. Forty buffers have recently been built and tested with 69 dB +2 dB back-to-front isolation. This result is an improvement over past results. When these new buffers are assembled in distribution amplifiers, higher back-to-front and port-to-port isolation test results are expected. The load isolation test result is from data of statistical measurements. Phase data were repeatedly averaged before and after a load change to each port of a distribution amplifier. The statistical mean and standard deviation resulted in a worst case -115 dB isolation factor. Harmonic signal generation is typically 56 dB below a 5 MHz carrier frequency. All other harmonics are lower, and there are no spurious signals out to 1 GHz. The 3 dB bandpass response is 15 KHz to 55 MHz at a nominal output level of +13 dBm. The gain can be adjusted easily between 1 and 10 dB by changing one resistor and one capacitor value. The VSWR at 5 MHz is less than 1.02 for both the input and the output. Power supply requirements can be either 60 mA at 24 volts or 50 mA at 28 volts. The newest buffer uses a 28 volt supply.

PHASE STABILITY	2.7 x 10 ⁻¹⁴ s AT 1 S AVERAGING TIME
TEMPERATURE COEFFICIENT	< 1.0 ps/°C
POWER SUPPLY VOLTAGE COEFFICIENT	< 0.1 ps/VOLT
MECHANICAL SHOCK SENSITIVITY	< 1.0 ps AT 10 G
60 Hz AC MAGNETIC FIELD (60 Hz NOISE RESPONSE)	-129 dB /10 GAUSS
ISOLATION AT 5 MHz	
BACK-TO-FRONT	-67 dB
BACK-TO-FRONT (WITH POWER SPLITTER)	-120 dB
PORT-TO-PORT (WITH POWER SPLITTER)	-90 dB
PORT-TO-PORT (SHORT/OPEN LOAD)	-115 dB
HARMONICS	-56 dB AT 10 MHz -68 dB AT 15 MHz
FREQUENCY RESPONSE (3dB)	15 KHz TO 55 MHz
MAXIMUM OUTPUT LEVEL	+13 dBm
GAIN	0 TO 10 dB
VSWR (50Ω/5 MHz)	< 1.02 AT INPUT AND OUTPUT
SIZE	2 x 2 x 1.25 IN.
POWER	60 mA AT 24 V OR 50 mA AT 28 V

Table 2. Buffer Amplifier Data Sheet

Table 3 is a data summary for the phase comparator. The phase stability is 27 femtoseconds for about 1 second averaging times (1). Phase comparators also have less than 1 ps/°C temperature coefficients. Their power supply voltage coefficients are less than 1.0 ps/volt for both +15 volt supplies and less than 0.1 ps/volt for the 24 volt supply. When placed in a 60 Hz AC magnetic field. The worst case 60 Hz peak is -120 dB. Port-to-port isolation at 5 MHz is -100 dB. The phase comparator's usable frequency range is between 100 KHz and 55 MHz. The phase comparator will respond to relatively low input levels and has been used to intercompare different carrier frequencies through internal harmonic generation. An RF input level of +13 dBm should not be exceeded to obtain the best performance. The phase comparator puts out a TTL compatible square-wave, phase coherent with the beat frequency of the two mixed RF signals. A 120 mA supply at 24 volts powers the buffers in the phase comparator. A +20 mA supply at +15 volts supplies the zero-crossing detector electronics.

PHASE STABILITY	2.7 x 10 ⁻¹⁴ s AT 1 S AVERAGING TIME
TEMPERATURE COEFFICIENT	< 1.0 PS/°C
POWER SUPPLY VOLTAGE COEFFICIENT	< 1.0 PS/VOLT FOR ±15V < 0.1PS/VOLT FOR +24V
60 Hz AC MAGNETIC FIELD	-120 DB AT 10 GAUSS (WITH SHIELD, 60Hz NOISE RESPONSE)
ISOLATION (PORT-TO-PORT, 5 MHz)	-100 DB
FREQUENCY RESPONSE	100 KHZ TO 55 MHz
MAXIMUM INPUT LEVEL	+13 DBM
OUTPUT LEVEL	TTL
SIZE	6 x 4 x 1.5 IN.
POWER	120 mA AT 24 V AND ±20 mA AT ±15 V

Table 3. Phase Comparator Data Sheet

CONCLUSION

These low noise buffer amplifiers, distribution amplifiers, and phase comparators are presently being built and tested at BFEC. Specialized tests and test systems are used to verify each devices' performance. The buffer amplifier design has been improved by shortening lead lengths to increase back-to-front isolation, by increasing the power supply level to reduce harmonic distortion at higher output levels, and by potting the buffer to reduce phase sensitivity to mechanical shocks. Distribution amplifier improvements are made by using a higher isolation power splitter for increased port-to-port isolation and by using higher isolation RF cables and connectors for increased back-to-front isolation. The phase comparator design has been improved by changing power supply connectors and securing circuit boards to increase their mechanical stability. All three devices are assembled in various configurations for use in many different precise time and frequency measurement and distribution systems.

Each of the devices and systems of devices are extensively tested to verify a performance level that does not add any significant measurement system noise to the phase of state-of-the-art hydrogen masers. Phase stability floors of 27 femtoseconds and long term stabilities of one picosecond have been measured on all measurement systems using these devices. They have shown temperature coefficients, power supply voltage coefficients and mechanical shock coefficients of less than one picosecond. The distribution amplifiers and the phase comparators presently have greater than 90 dB of isolation and later should have greater than 100 dB of isolation.

In conclusion, BFEC builds, tests and improves these devices to reliably exceed these performance results just outlined. These devices should have application in various other high stability measurement and distribution systems.

REFERENCES

1. V.S. Reinhardt, W.A. Adams, G.M. Lee and R.L. Bush, "A Modular Multiple Use System for Precise Time and Frequency Measurement and Distribution", 10th Annual PTTI Applications and Planning Meeting, (Washington, D.C., 1978).
2. A.E.E. Rogers, "Frequency Standard Buffer Amplifier for Use in Very Long Baseline Interferometry", Haystack Observatory Technical Note, 1975-3.
3. D.W. Allan and H. Daams, "Picosecond Time Difference Measurement System", 29th Annual Frequency Control Symposium, (Atlantic City, N.J., 1975).
4. Model QHF-2A-5, Merrimac Industries Inc., West Caldwell, N.J.