

CONSERVATION OF STRATEGIC AEROSPACE MATERIALS (COSAM)

Joseph R. Stephens
NASA Lewis Research Center

SUMMARY

NASA has undertaken several projects directed at conserving strategic materials used in the aerospace industry. Research efforts involving universities and industry as well as in-house activities at the NASA Lewis Research Center comprise the current "Conservation of Strategic Aerospace Materials" COSAM effort. The primary objective of COSAM is to help reduce the dependence of the United States aerospace industry on strategic metals, such as cobalt (Co), columbium (Cb), tantalum (Ta), and chromium (Cr), by providing the materials technology needed to minimize the strategic metal content of critical aerospace components for gas turbine engines. Thrusts in three technology areas are appropriate for COSAM. These include near-term activities in the area of strategic element substitution; intermediate-range activities in the area of materials processing; and long-term, high-risk activities in the area of "new classes" of high temperature metallic materials. This paper describes in some detail the efforts currently underway and the initial results generated to date. Initial emphasis has been placed in the area of strategic element substitution. Specifically, the role of cobalt in nickel-base and cobalt-base superalloys vital to the aerospace industry is being examined in great detail by means of cooperative university-industry-government research efforts. Investigations are also underway in the area of "new classes" of alloys. Specifically, a study has been undertaken to investigate the mechanical and physical properties of intermetallics that will contain a minimum of the strategic metals. Current plans for COSAM are presented in this paper also.

INTRODUCTION

The United States relies heavily upon foreign sources for the supply of most strategic metals required by our aerospace industry. With the exception of molybdenum, iron, magnesium, and the rare earths, the United States imports from 50 to 100 percent of such aerospace metals as Co, Cb, Ta, Cr, and Mn (ref 1). However, the potential for foreign cartels, political unrest, and production limitation is great and is intensified by steadily declining known reserves. Thus, the United States can expect to be faced with supply shortages and price escalation for many strategic metals. Since these metals are vital to the welfare of the nation's economy, their continued availability at a reasonable cost is a national issue which requires cooperative action between the aerospace industry and appropriate government agencies.

The aerospace industry is currently a major factor in the positive inflow of funds from U.S. exports (ref. 2). This industry, and within it the aircraft engine industry in particular, relies heavily upon imports for several key strategic metals including cobalt, columbium, tantalum, and chromium. In order to offset or minimize future disruptions in supply, efforts to develop viable options must begin now, since a new material can take from 5 to 10 years of research and development efforts before qualifying for aerospace service.

NASA currently has plans to address the aerospace industry's needs to minimize the use of strategic metals for advanced aerospace systems. COSAM has as its broad objective the reduction of the dependence of the U.S. aerospace industry on strategic metals. This objective can be accomplished by providing the materials technology options needed to allow individual companies to trade-off the material properties of critical components versus cost and availability of their strategic metal content. This paper summarizes NASA's current activities in this area and broadly outlines the plans for COSAM.

STRATEGIC MATERIALS

A definition of strategic materials as used in this paper is given in figure 1. Strategic materials are those predominantly or wholly imported elements contained in the metallic alloys used in aerospace components which are essential to the strategic economical health of the U.S. aerospace industry. As the basis for what are considered strategic metals, we will focus on the aircraft engine industry's needs. Based on a survey of the ASME Gas Turbine Panel and a subsequent survey of a number of aerospace companies, the elements listed in figure 1 were considered to be the most strategic with respect to the aerospace industry. As a result of prioritizing by NASA's COSAM planning team supplemented by further discussions with several aircraft engine manufacturers, four elements emerged that were of particular concern. The alloys used to build the critical high temperature components for aircraft propulsion systems require the use of the four metals - cobalt, columbium, tantalum, and chromium. These metals are contained in steels, stainless steels, and superalloys that are used in engine manufacturing. Figure 2 lists these four elements in the high priority category with a brief rationale for this ranking. The remaining five strategic elements evolving from our surveys were given a lower priority and figure 2 also contains a short explanation for this ranking.

The location of these metals in aircraft engine compressors, turbines, and combustors is illustrated in figure 3. The need for such metals has increased as the demands have grown for higher durability plus high performance, fuel efficient aircraft turbine engines. Based on the essential nature of these metals and for the U.S. aircraft industry to maintain its competitive position, it is necessary that supplies be readily available at a reasonably stable cost. To achieve these requirements, domestic sources of key metals are desirable.

Today, we are almost totally dependent on foreign sources for these metals as shown in figure 4. In several of the countries listed in figure 4, recent political disturbances have led to supply interruptions. Therefore, the U.S. aircraft engine industry can be seen to be highly vulnerable to supply instabilities of the essential metals for engine manufacturing. Accompanying supply disruptions or increased demand is an accelerated price increase. Escalated prices during the recent few years are evident for tantalum, columbium, cobalt, and to a lesser degree for chromium, as shown in figure 5. These rapid price increases illustrate the additional vulnerability of the U.S. aircraft engine industry to cost fluctuations. The essential nature of cobalt, columbium, tantalum, and chromium along with their vulnerability to supply instabilities and cost fluctuations combine to cause these metals to be classified as strategic aerospace metals.

The portion of these four metals used in superalloys for the aerospace industry compared to all other U.S. uses is shown in figures 6 to 9. The use of these metals in superalloys as compared to total U.S. consumption in 1979 was: cobalt - 30 percent, columbium - 28 percent, tantalum - 5 percent, and chromium - 3.4 percent. These data reveal that superalloys comprise the largest single use of both cobalt and columbium.

OVERVIEW OF COSAM

COSAM has as its primary objective the reduction of the dependence of the U.S. aerospace industry on strategic metals. COSAM can also provide the industry with some options for making their own property versus availability/cost trade-offs when selecting aerospace alloys. These objectives will be achieved by providing the technology needed to minimize the strategic metal content of critical components in aerospace structures. Initial emphasis will be placed on the aircraft engine industry. COSAM initially is focused on conservation of the strategic metals cobalt, columbium, tantalum, and chromium. Strategic metals such as titanium, the precious metals, tungsten, and others may be brought into COSAM as it progresses.

Along with prioritizing the strategic elements that were identified, the role that the NASA's COSAM effort should encompass was also evaluated. Options that were considered are listed in figure 10. All of these options could contribute to the conservation of strategic materials and minimization of U.S. aerospace industry vulnerability. However, within the scope of our program a decision was reached based on Lewis' traditional roles and expertise to focus on the three areas noted in figure 10. These areas consist of strategic element substitution, process technology, and alternate materials. Contributions to the other areas may benefit from COSAM through cooperative programs with other governmental agencies such as in the area of scrap reclamation or through cooperation with technical societies in establishing a critical material index. Having selected a list of four high priority strategic elements and having defined the areas of emphasis for COSAM and specific objectives, a technology approach was adopted as shown in figure 11. Conservation, as well as reduced dependence on strategic metals, will be achieved in the

area of strategic element substitution by systematically examining the effects of replacing cobalt, columbium, and tantalum with less strategic elements in current, high use engine alloys. This will help guide future material specifications if one or more of these metals becomes in short supply. Conservation through process technology will be achieved by advancements in those net-shape and tailored-structure processes that minimize strategic material input requirements. This will lower total usage. And in the longer term, development of alternate materials that replace most strategic metals with those highly available in the U.S. could lead to a substantial reduction in the U.S. dependence on foreign sources. Both of the later two technology areas will help conserve the four strategic metals Co, Cb, Ta, and Cr.

EARLY COSAM ACTIVITIES

COSAM efforts began in FY'80. Efforts on planning and organizing are still underway. In addition to the planning activities, several small research activities have been initiated. These research activities focus on two of the three major thrusts of COSAM - strategic element substitution and development of alternate materials. Special emphasis of these initial efforts is on developing a fundamental understanding of the role of strategic elements in current aircraft engine alloys so that effective alloying element substitution can be conducted. Similarly, in the development of alternate materials, a basic understanding of materials properties and alloying concepts is being emphasized. Consequently, university grants play a major part in COSAM. In addition, cooperative programs with industry augmented by in-house research at the NASA Lewis Research Center comprise the approach used in these initial projects. This cooperative approach will continue to be followed in COSAM and industry, universities, and government in-house research will each play a key role. The subsequent paragraphs will describe in some detail early COSAM research efforts.

Strategic Element Substitution

Four metals were mentioned previously as being classified as high priority strategic metals. Cobalt was selected from these four metals for the early COSAM strategic element substitution research. The basis for selecting cobalt was twofold. First, the largest single use of cobalt in the U.S. is in superalloys for jet engine applications as was shown in figure 9 (ref. 3). Many of the other applications indicated in figure 9 are also important to the nation's economy and security as well. Secondly, the specific roles that cobalt plays in nickel-base superalloy fabrication and performance has not been clearly established. Most superalloys currently in use were developed at a time when cobalt was plentiful and inexpensive. Literature results (Ref. 4) are conflicting as to the role that cobalt plays in nickel-base superalloys in important areas such as phase stability, γ' partitioning, strength, fabricability, and oxidation and hot corrosion resistance. Because of these uncertainties, there exists a strong possibility that the strategic element cobalt can be substantially reduced or possibly eliminated from several superalloys without sacrifice of the key properties for which these alloys were selected for engine service.

Four nickel-base and one cobalt-base superalloys were selected for this investigation. The five alloys are listed in figure 12 along with their typical applications in the aircraft engine industry, the forms in which the alloys are used, and remarks as to why they were selected for this activity. Applications include turbine disks, turbine blades, and combustors. A variety of product forms are represented by the applications of the five alloys as noted in figure 12. The selection of the five alloys was based primarily upon the considerations given in this figure. Waspaloy* was selected because it represents the highest tonnage of cobalt now in commercial aircraft engines. Selection of Udimet-700* was based on the fact that this alloy is used in the as-cast, as-wrought ingot, as-wrought powder, and as-HIP powder metallurgy fabricated conditions. The potential for determining the impact of cobalt on both conventionally cast as well as on single crystal turbine blades was the reason for selecting Mar-M247*. Rene' 150* was chosen because it is one of the most advanced directionally solidified alloys. The wrought, sheet alloy HA-188* was selected because it represents one of the largest uses of a cobalt-base alloy in aircraft engines.

The primary purpose of the cobalt strategic element substitution research is to determine the fundamental role of cobalt in a wide variety of nickel-base superalloys and in a high-use cobalt-base superalloy. A secondary purpose is to develop the methodology to explore the roles of other strategic elements in similarly chosen alloys so as to have maximum impact on a wide range of users.

Figure 13 shows the participants in this COSAM effort on cobalt strategic element substitution. These initial research efforts are planned for a three-year period and consist of cooperative programs involving universities, industry, and NASA Lewis Research Center. Nominal compositions of the five alloys given in figure 13 indicate that cobalt content ranges from 10 percent in Mar-M247 to 39 percent in HA-188. In addition, the γ' phase ranges from 20 percent in Waspaloy to 65 percent in Rene' 150. The first phase in each research effort will involve substituting the less strategic element, nickel, for cobalt in incremental steps to a zero cobalt content. The effect of this substitution on properties and phases present, such as γ' , will make up the major portion of the research effort in the first year of each program element. Efforts in subsequent years will be directed at identifying and optimizing alloying elements as substitutes for cobalt in the five alloys so as to maintain the key properties of these alloys.

The cooperative nature of the research being conducted on Waspaloy and Udimet-700 is illustrated in figure 14. The role of industry as represented by Special Metals Corporation is outlined. Their primary role is to characterize and optimize fabrication and heat treating procedures for the reduced

*Trademarks

Waspaloy	United Technologies Corporation
Udimet	Special Metals Corporation
Mar-M	Martin Marietta Corporation
Rene'	General Electric Corporation
HA	Cabot Corporation

cobalt Waspaloy and Udimet-700 alloys. The university role in this effort is also shown in figure 14. Columbia University will be involved with mechanical property characterization, structural stability, microstructural features, and theoretical formulations to identify future alloy modifications if required for the second phase of the project. Purdue University will be primarily responsible for microstructural and microchemistry characterization of the reduced cobalt content alloys. To round out the program, NASA Lewis Research Center will be involved in further mechanical and physical metallurgy characterization of the alloys as shown in figure 14. The output of this cooperative effort is expected to be a clearer understanding of the role of cobalt in nickel-base superalloys.

Some preliminary results on the effects of reducing cobalt in Waspaloy, a 13 percent cobalt alloy, are shown in figure 15 (ref. 5). Tensile strength appears to be insensitive to the amounts of cobalt in the alloy. However, rupture life decreased with decreasing amount of cobalt in Waspaloy. Further testing will be required to better characterize this apparent effect.

Similar effects of cobalt on the rupture life of Mar-M247 have been determined as shown in figure 16 (ref. 6). A possible contributing cause to this reduction in rupture life is the decrease in amount of γ' in this alloy with decreasing cobalt content as shown in figure 17. Also shown in figure 17 is the change in γ' composition. As cobalt is removed from the alloy, the largest change in the composition of γ' is the increase in tungsten content. Further studies are underway to clarify the role of cobalt in this alloy.

The research efforts on Udimet-700 and Rene' 150 parallel the previously described efforts on Waspaloy and Mar-M247. It is anticipated that these studies will lead to an understanding of the fundamental role of cobalt in a variety of conventional and directional nickel-base superalloys. These results should provide an improved technical base to develop modified superalloys in later stages of COSAM, as illustrated in figure 18.

Alternate Materials

Research in this area must be considered to be high risk and long range, but it has the potential of a high payoff in terms of significantly reducing the nation's dependence on strategic materials. As an example of alternate materials, intermetallic compounds are currently being investigated for possible structural applications. Initial efforts are centered on nickel and iron aluminides. Successful development of this type of alternate material offers the possibility of partially or totally replacing all the strategic materials in components where intermetallic compounds can be utilized.

Intermetallic compounds are of interest because of their potential high temperature strength as shown in figure 19 (ref. 7). It can be seen in this figure that nickel aluminides have the strength capability of competing with current nickel-base alloys. However, a possible disadvantage of this type of material is that simple binary aluminide compounds have shown a lack of room temperature ductility (fig. 20). The factors which influence the high ductile-

to-brittle transition temperature of nickel aluminide ($\sim 600 + ^\circ\text{C}$) are currently being investigated. A NASA grant with Dartmouth University is aimed at understanding the fundamental deformation mechanisms in nickel aluminide. From these investigations, methods of improving the low temperature ductility of nickel aluminide may be suggested. An accompanying in-house research project at NASA Lewis Research Center is focusing on the high temperature mechanical properties of aluminides. These studies can provide a fundamental basis for more extensive research to develop these nonstrategic, alternate materials as shown in figure 21.

COSAM PLANS

Future COSAM efforts can build on the fundamental understanding from the early research for cobalt substitution, as was shown in figure 18. Major efforts will be devoted to developing, and if warranted, to scaling-up low or no-cobalt nickel-base superalloys for fabrication into various components. Demonstration of continued promise could also lead to verification in engine tests by major engine producers. Similar efforts will also be conducted for other strategic metals such as columbium and tantalum.

In the area of alternate materials, much more work will be required to develop materials such as intermetallic compounds. As was shown in figure 21, initial efforts will focus on fundamental studies aimed at improving low temperature ductility and high temperature strength of FeAl and NiAl intermetallics. Complete property characterization will follow on more promising compositions. Reiterations of these basic steps will be required to further optimize the alternate materials and make them viable candidates as structural materials for aircraft engines. Scale-up and rig testing of promising compositions for blades and vanes will follow. The development of alternate materials will help conserve the strategic metals Co, Cb, Ta, and Cr.

A third area of the COSAM consideration involves conservation through improved materials processing technology. Although none of these activities have been initiated, plans have been made for investigating processing technology in such areas as advanced melting techniques, tailored fabrication, advanced coatings, joining techniques, and fabrication efficient processes. A reduction in strategic material usage should result from these processing technologies. For example, early efforts on near-net-shape fabrication of a turbine disk (ref. 8) have been shown to be able to reduce input material weight compared to conventional casting/forging practice and further gains appear possible. Improved processing technology will also help conserve the strategic metals Co, Cb, Ta, and Cr.

CONCLUDING REMARKS

This paper has presented NASA's COSAM efforts and planning. The primary points are summarized below:

1. Advancements in materials technologies are needed to provide the aerospace industry with alternative materials options in the event of future strategic metal shortages or excessive price increases.
2. The primary role of NASA's COSAM efforts will be to address strategic material problems within the aerospace industry. COSAM should make contributions to a national data base that will benefit many other domestic industries as well.
3. COSAM was designed to involve cooperative research efforts with industry (alloy producers, component fabricators, and engine manufacturers), with universities, and with government research facilities (primarily the Lewis Research Center).

REFERENCES

1. Mineral Commodity Summaries 1979. Bureau of Mines, U.S. Department of the Interior, 1979
2. "Aerospace Review and Forecast 1979/80", Aerospace, vol. 18, no.1, Winter, 1980, pp. 2-4.
3. Mineral Industry Surveys. Bureau of Mines, U.S. Department of the Interior, Dec. 1979.
4. Tien, J. K.; et al.: Cobalt Availability and Superalloys. J. Metals, vol. 32, no. 10, 1980, pp. 12-20.
5. Maurer, G. E.; Jackman, L. A.; and Domingue, J. A.: Role of Cobalt in Waspaloy. Superalloys 1980, J. K. Tien, ed., American Society for Metals, 1980, pp. 43-52.
6. Nathal, M.: The Role of Cobalt in a Nickel Base Superalloy. Presented at the AIME 110th Annual Meeting, Chicago, Ill., Feb. 22-26, 1981.
7. Schulson, E. M.: The Ductility of Polycrystalline NiAl. Oral Presentation at NASA Lewis Research Center, Sept. 1979.
8. Dreshfield, R. L.; and Miner, R. V., Jr.; Application of Superalloy Powder Metallurgy for Aircraft Engines. NASA TM-81466, 1980.

STRATEGIC MATERIALS

- **DEFINITION:** THOSE PREDOMINANTLY OR WHOLLY IMPORTED ELEMENTS CONTAINED IN THE METALLIC ALLOYS USED IN AEROSPACE COMPONENTS WHICH ARE ESSENTIAL TO THE STRATEGIC ECONOMIC HEALTH OF THE U. S. AEROSPACE INDUSTRY

- **SURVEY RESULTS**

A. S. M. E. GAS TURBINE PANEL SURVEY

STRATEGIC ELEMENTS IDENTIFIED

Cb, Co, Cr, Ta, AND W

NASA AEROSPACE COMPANY SURVEY

(ADDITIONAL ELEMENTS)

Mn, Pd, Pt, Sn

Figure 1. - COSAM background.

HIGH PRIORITY

- Co** SUPERALLOYS LARGEST SINGLE USER (30% OF TOTAL)
- Cb** SUPERALLOYS LARGEST SINGLE USER (28% OF TOTAL)
- Cr** CRITICAL TO ENVIRONMENTAL RESISTANCE OF ENGINE COMPONENTS
- Ta** CRITICAL TO ADVANCED ENGINE ALLOYS

LOWER PRIORITY

- W** NEW U. S. MINES ON STREAM, PROJECTED SELF-SUFFICIENCY BY 1985
- Mn** WIDELY USED IN STEEL INDUSTRY, HOWEVER POTENTIAL LOW COST ALTERNATIVE TO Ni
- Pd, Pt** USED FOR ELECTRICAL/ELECTRONIC APPLICATIONS
- Sn** USED FOR Al AIRFRAME ALLOYS AND IN SOME Ti ENGINE ALLOYS

Figure 2. - Strategic element focus.

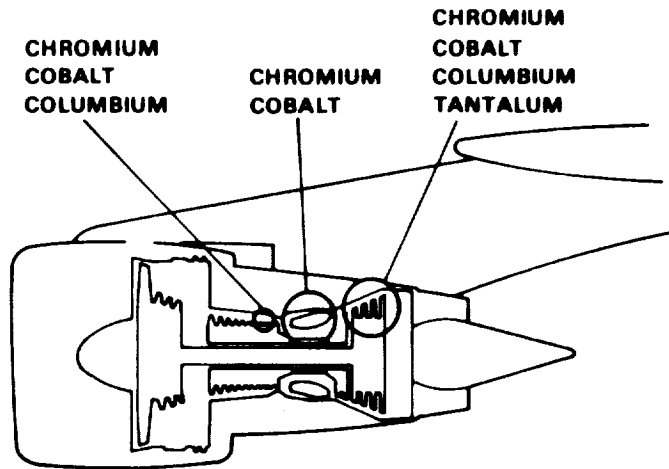

NEEDED FOR PERFORMANCE AND LONG LIFE
COBALT – HIGH TEMPERATURE STRENGTHENER
COLUMBIUM – INTERMEDIATE TEMPERATURE STRENGTHENER
TANTALUM – OXIDATION RESISTANCE
CHROMIUM – CORROSION RESISTANCE

Figure 3. - Strategic metals are critical to turbine engines.

METAL	% IMPORTED	MAJOR FOREIGN SOURCE
COBALT	97	ZAIRE
COLUMBIUM	100	BRAZIL
TANTALUM	97	THAILAND
CHROMIUM	91	SOUTH AFRICA, ZIMBABWE

Figure 4. - U. S. aerospace is vulnerable to supply instabilities.

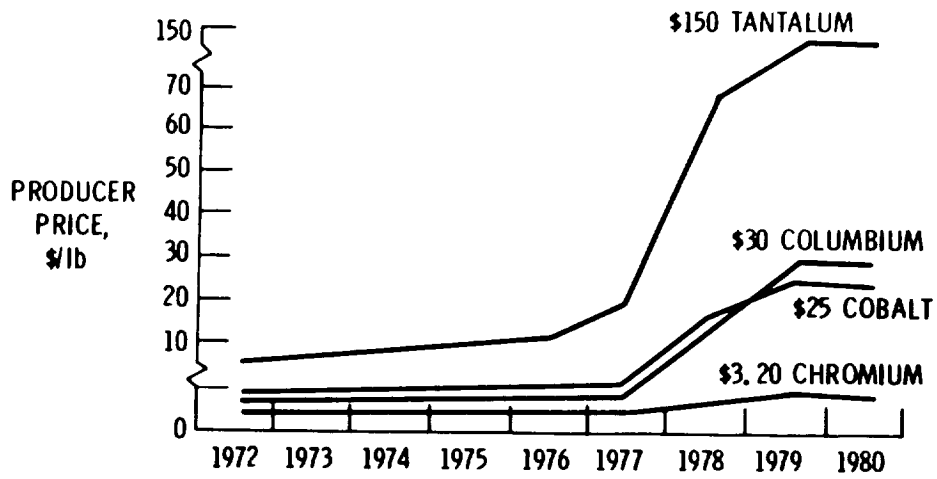

Figure 5. - U. S. aerospace is vulnerable to cost fluctuations.

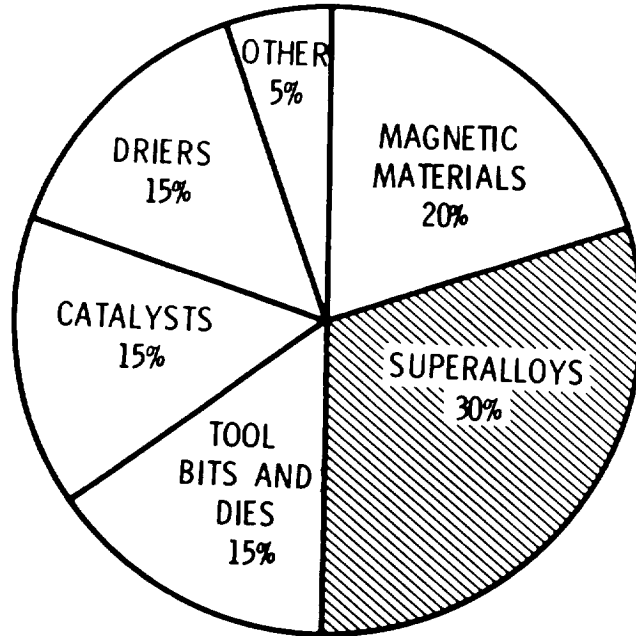

Figure 6. - U. S. consumption of cobalt in 1979 (Total pounds, 20.3 million).

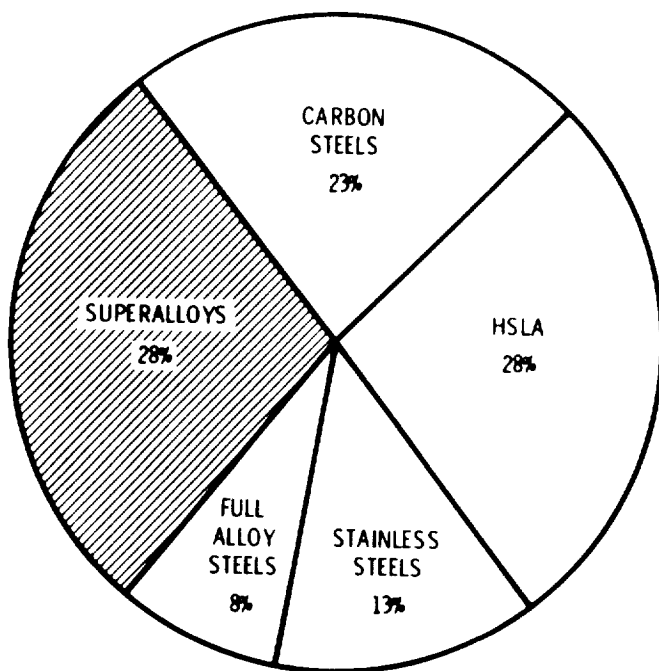

Figure 7. - U. S. consumption of columbium in 1979 (Total pounds, 6.3 million).

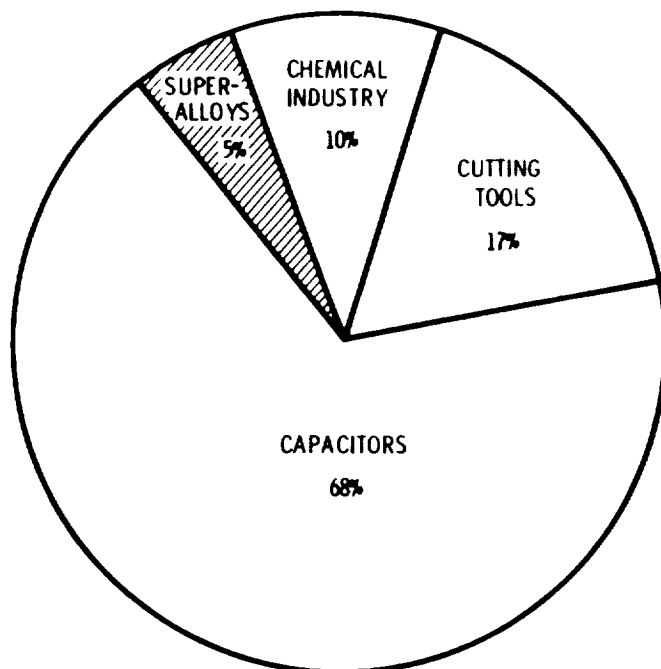

Figure 8. - U. S. consumption of tantalum in 1979 (Total pounds, 1.7 million).

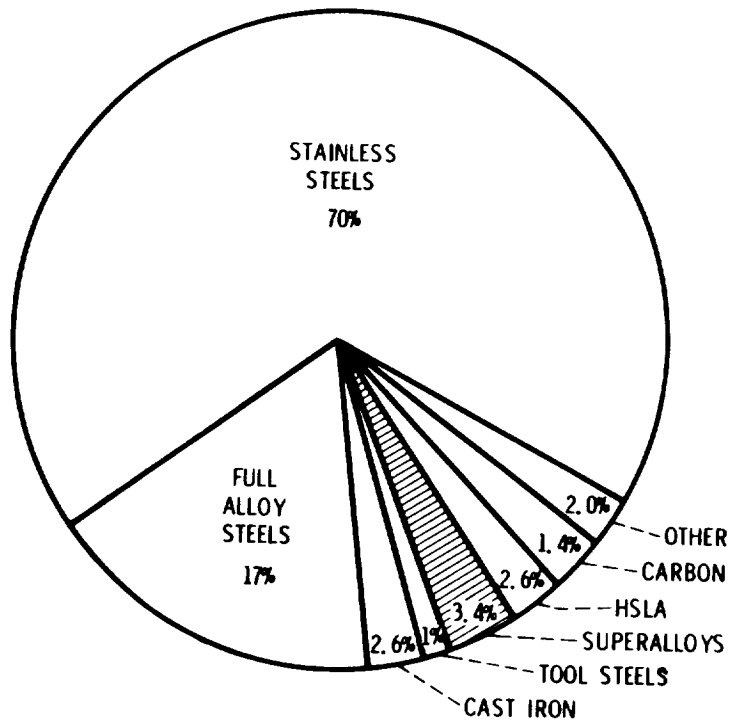

Figure 9. - U. S. consumption of chromium in 1979 (Total pounds chromium ferroalloys, 1.0×10^9).

OPTIONS CONSIDERED IN PREPARATION FOR STRATEGIC MATERIALS SHORTAGE

- EXPAND EXPLORATION
- IMPROVED RECOVERY
- STRATEGIC MATERIAL SUBSTITUTION ✓
- SCRAP RECLAMATION
- REDUCED WASTE IN PROCESSING ✓
- ALTERNATE MATERIALS ✓
- STOCKPILING
- CRITICAL MATERIAL INDEX

Figure 10.- Options considered in preparation for strategic materials shortage).

OBJECTIVE:

- PROVIDE TECHNOLOGY OPTIONS WHICH WILL SUPPORT THE AEROSPACE INDUSTRY IN MAKING STRATEGIC ECONOMIC DECISIONS AIMED AT SIGNIFICANTLY REDUCING STRATEGIC METAL CONSUMPTION
- Co, Cb, Ta, Cr, AND OTHERS AS IDENTIFIED

APPROACH:

- DEVELOP UNDERSTANDING OF ROLES OF Co, Cb, Ta, AND Cr IN CURRENT SUPERALLOYS
- IDENTIFY SUBSTITUTES AND LOW STRATEGIC METAL CONTENT ALLOYS
- DEVELOP PROCESS TECHNOLOGY THAT WILL MINIMIZE STRATEGIC METAL INPUT AND WASTE
- IDENTIFY ALTERNATE MATERIALS AND PROCESSES THAT HAVE HIGH LONG TERM POTENTIAL IN REDUCING STRATEGIC METAL USAGE (HIGHER RISK APPROACH)

Figure 11. - COSAM program objective and approach.

<u>ALLOY</u>	<u>TYPICAL ENGINE APPLICATION</u>	<u>FORM</u>	<u>REMARKS</u>
WASPALLOY	TURBINE DISK	FORGED	HIGHEST USE WROUGHT ALLOY IN CURRENT ENGINES
UDIMET-700 (LC) ASTROLOY (RENÉ 77)	TURBINE DISK TURBINE DISK LP BLADES	FORGED AS-HIP- POWDER CAST	} SIMILAR ALLOYS USED IN VARIOUS FORMS AND APPLICATIONS
MAR-M247	TURBINE BLADES	CAST	
RENÉ 150	TURBINE BLADES	DS-CAST	HIGHLY COMPLEX DIRECTIONALLY-CAST ALLOY
HA-188	COMBUSTORS	WROUGHT	HIGH USE COBALT-BASE SHEET ALLOY

Figure 12. - Superalloys selected for initial COSAM activities.

PARTICIPANTS	ALLOY	NOMINAL COMPOSITION										γ'
		Ni	Cr	Co	Mo	W	Ta	Re	Al	Ti	Hf	
COLUMBIA UNIV PURDUE UNIV SPECIAL METALS NASA-LEWIS	WASPALLOY	58	20	13	4	--	--	--	1.3	3	--	20%
COLUMBIA UNIV PURDUE UNIV SPECIAL METALS NASA-LEWIS	UDIMET-700	53	15	19	5	--	--	--	4.3	3.5	--	40%
CASE-WESTERN RESERVE UNIV TELEDYNE NASA-LEWIS	MAR-M247	60	8	10	.6	10	3	--	5.5	1	1.4	55%
NASA-LEWIS	RENÉ 150	59	5	12	1	5	6	3	5.5	--	1.5	65%
(TBD)	HA-188	22	22	39	--	14	--	--	--	--	--	--

Figure 13. - Elements of initial COSAM activities.

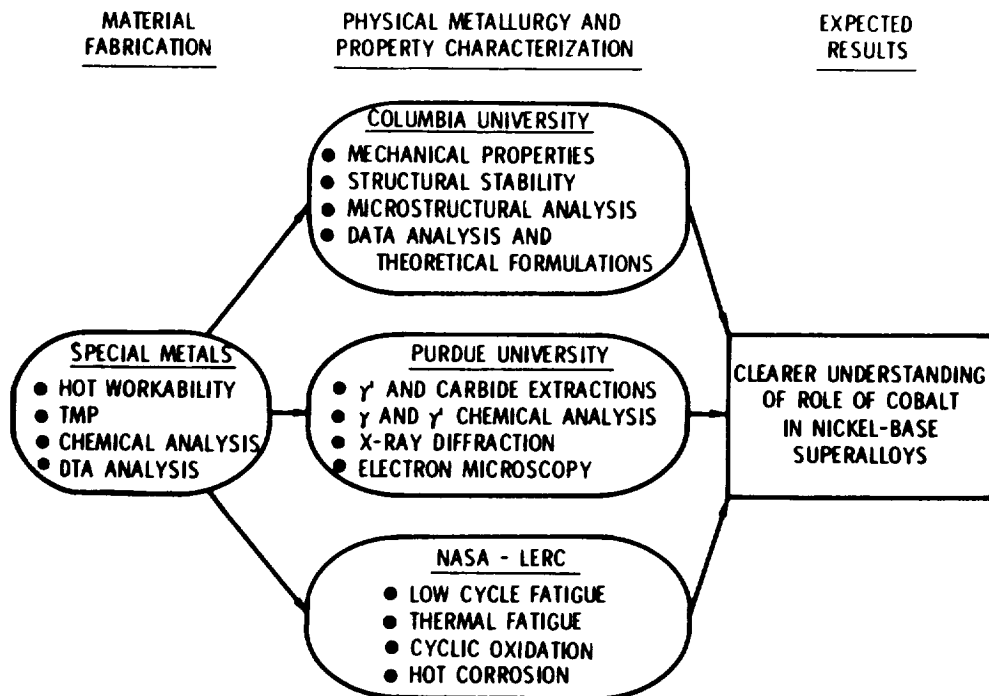

Figure 14. - Cooperative program to determine fundamental role of cobalt in Waspalloy and U-700.

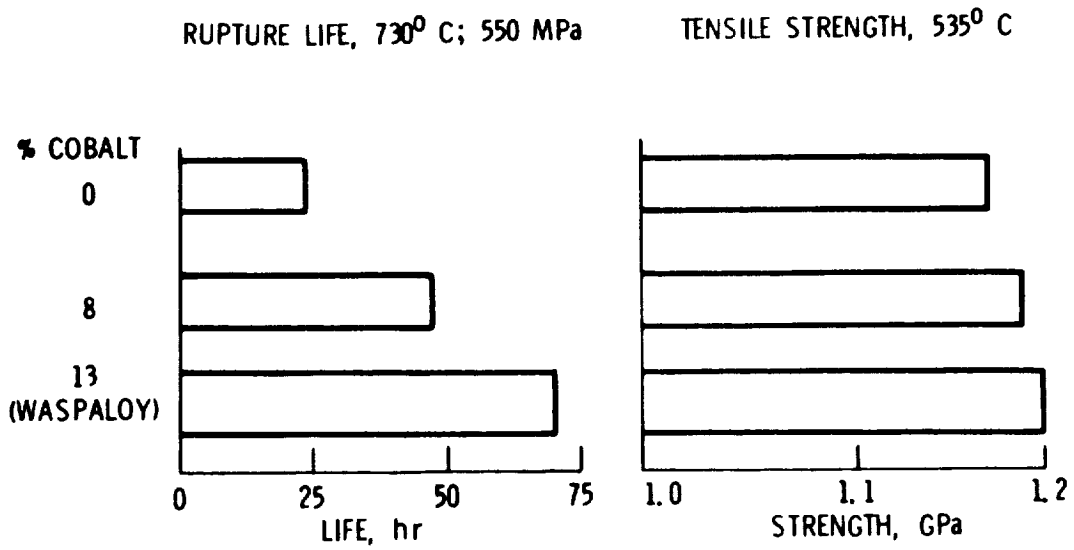

Figure 15. - Preliminary results of reducing cobalt in Waspaloy.

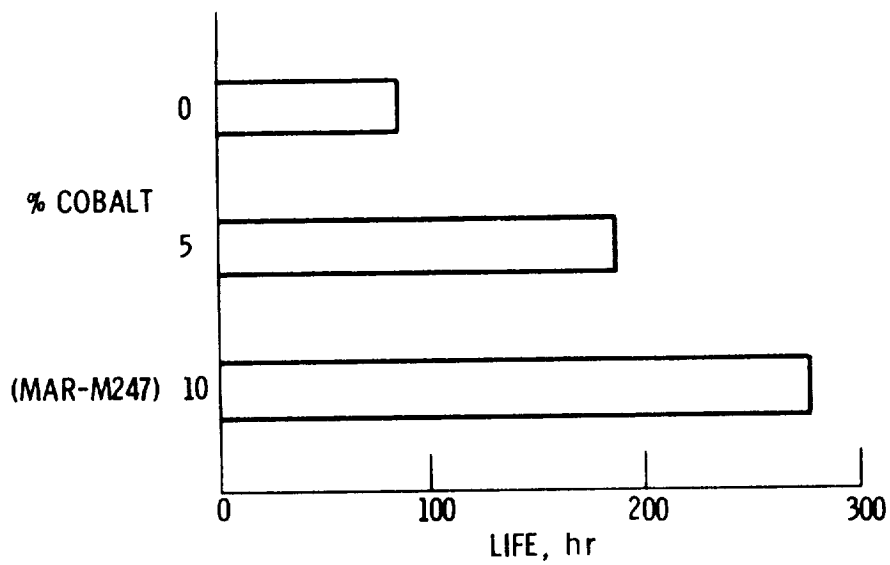

Figure 16. - Preliminary results of reducing cobalt in Mar-M247. (Rupture life, 870° C; 360 MPa.)

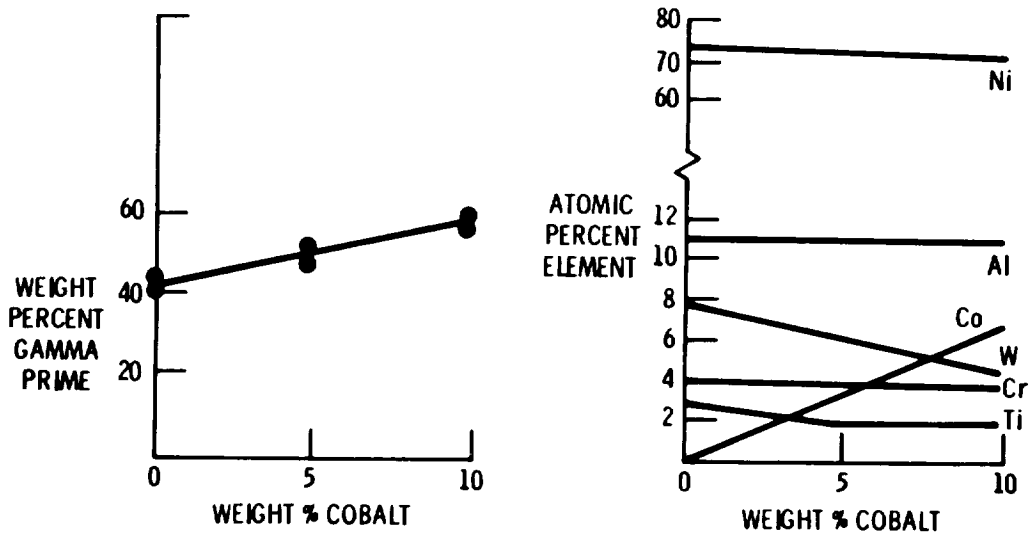

Figure 18. - Planned flow of COSAM strategic element substitution research.

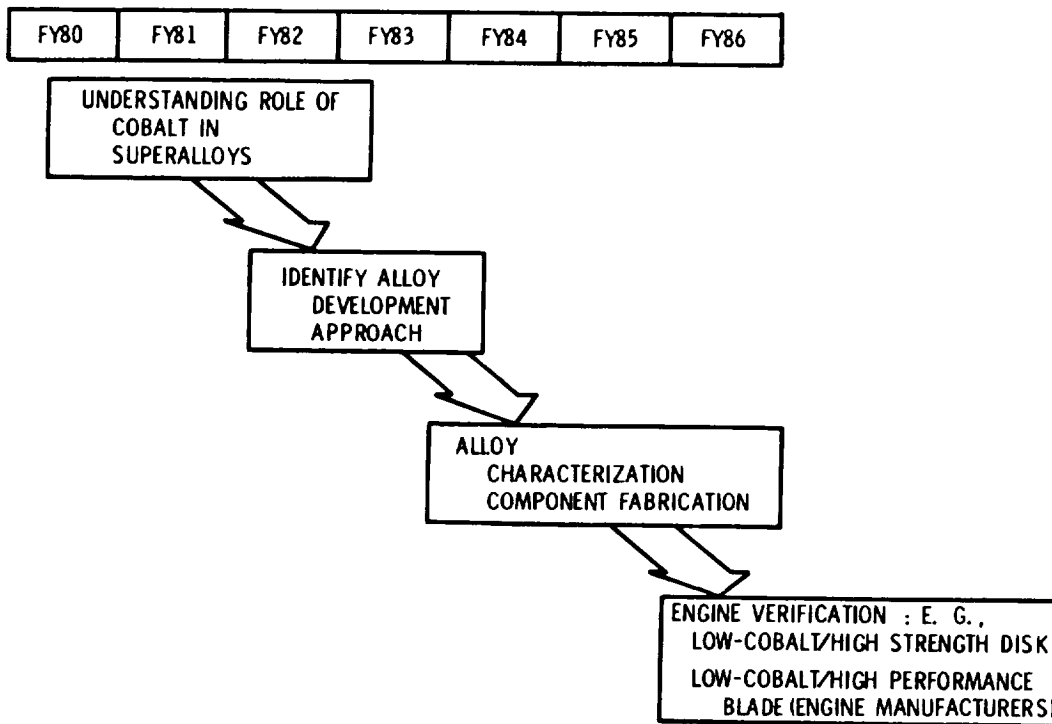

Figure 17. - Amount and composition of gamma prime as a function of cobalt content in Mar-M247.

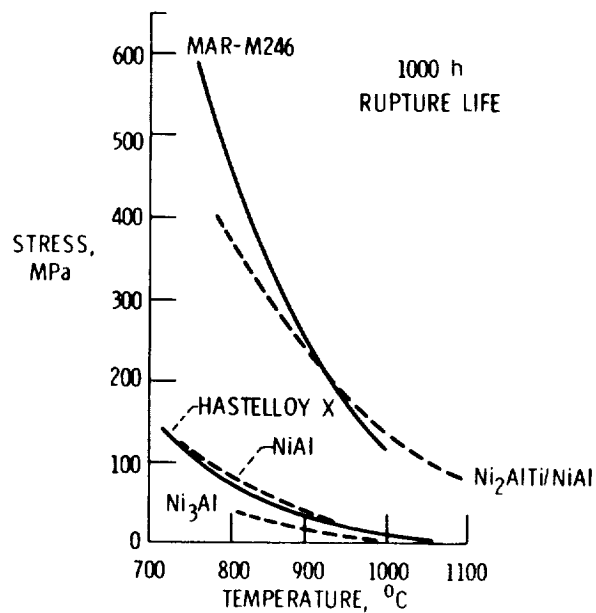

Figure 19. - Typical strengths of aluminides and superalloys.

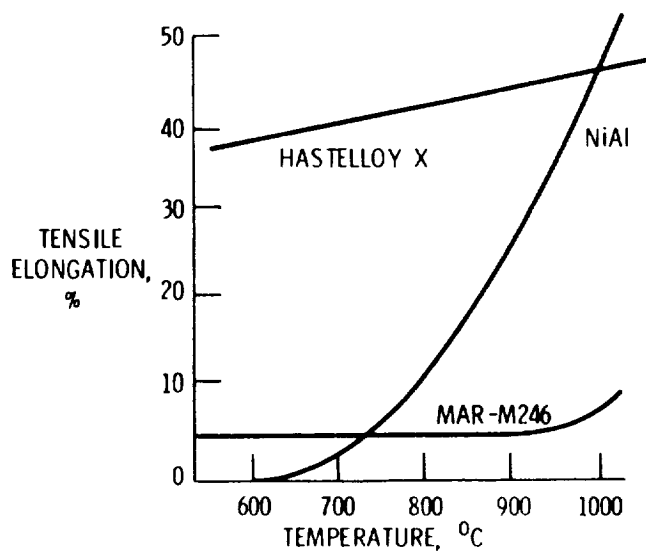

Figure 20. - Typical ductility values for aluminides and superalloys.

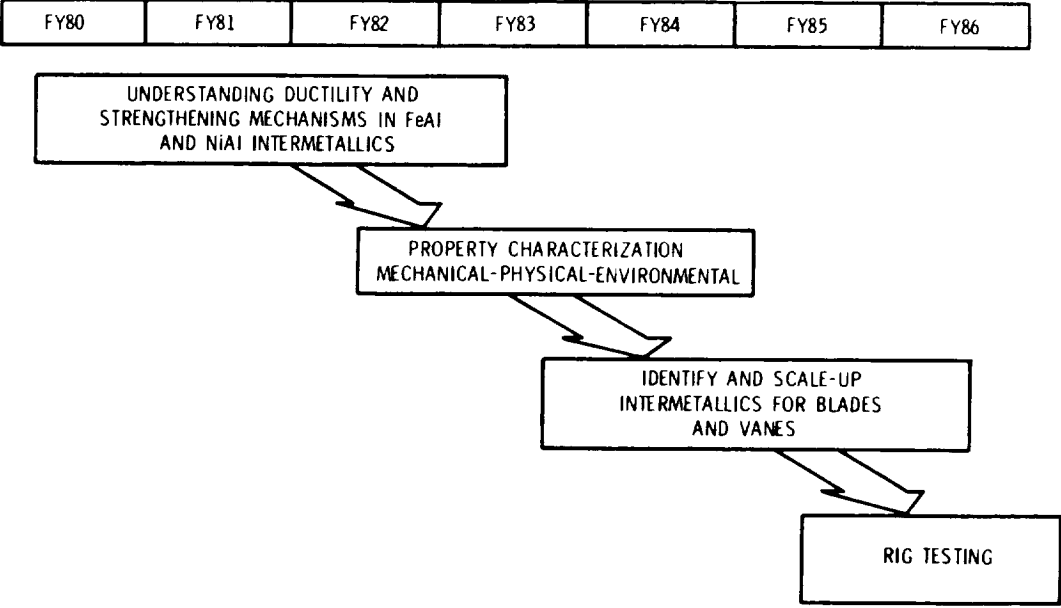

Figure 21. - Planned flow of COSAM alternate materials research.

