

ELECTROMAGNETIC ANALYSIS
FOR LARGE REFLECTOR ANTENNAS

M. C. Bailey
NASA Langley Research Center

LSST 2ND ANNUAL TECHNICAL REVIEW

November 18-20, 1980

REFLECTOR ANTENNA GEOMETRY

Geometric-optics aperture-integration is the basic technique selected for computing the radiation pattern of a reflector antenna. Using the feed pattern as a weighting factor, together with ray-tracing, the tangential electromagnetic field is found at many points in an aperture plane parallel to the y - z plane. Numerical integration of the aperture field yields the secondary far-field radiation pattern.

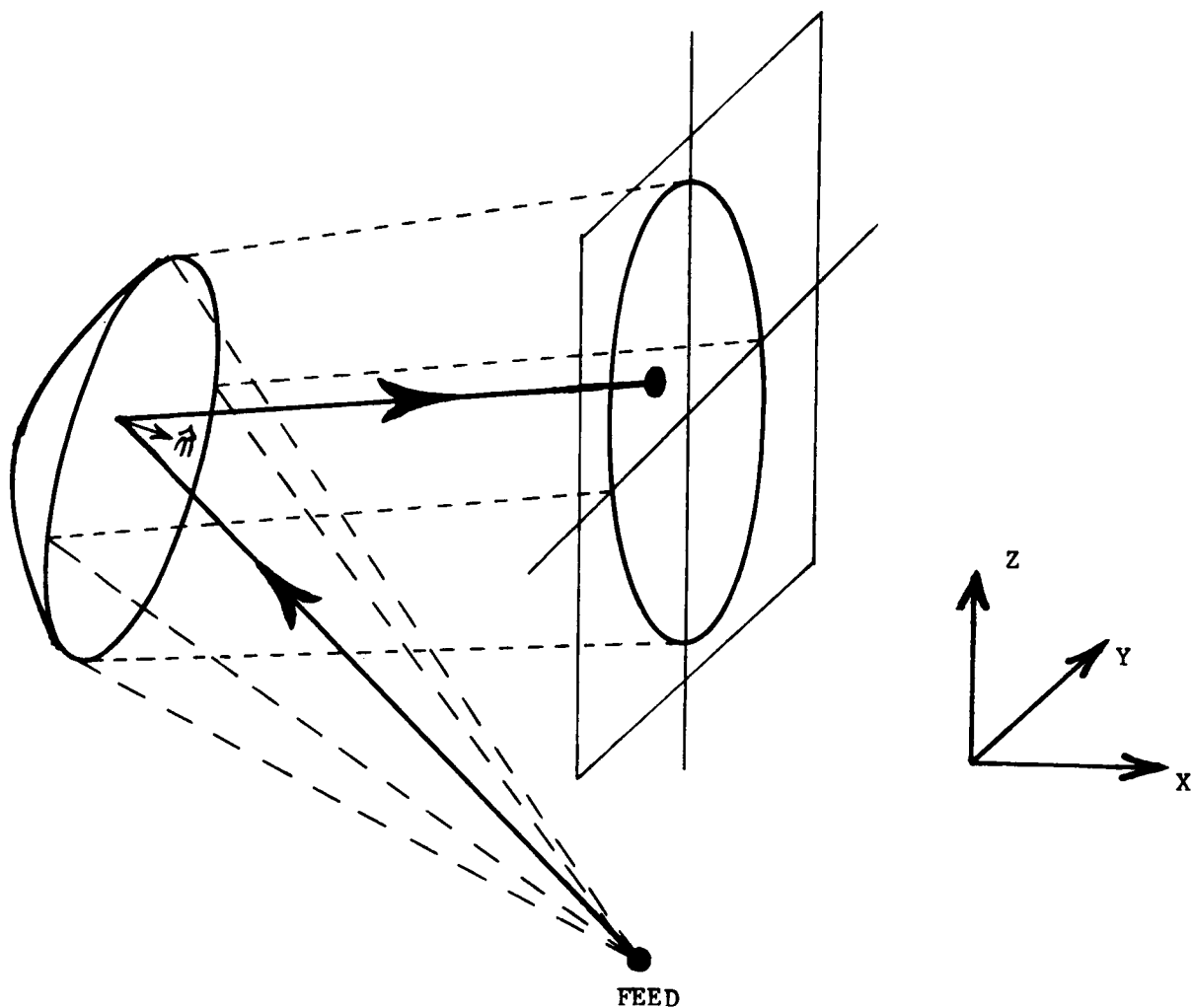

STATUS OF COMPUTER CODES

A variety of different reflector antenna geometries can be analyzed using the geometric-optics aperture-integration technique, which requires that the feed primary pattern and a description of the reflector surface be known. The present capability of the Langley computer codes for reflector antennas is listed here. Codes have been developed for reflectors whose surfaces are characterized by (a) an equation, (b) segments, (c) points in a uniform rectangular lattice arrangement, and (d) points distributed nonuniformly over the surface.

REFLECTOR ANTENNAS

ANALYTICAL SURFACE

- Paraboloidal
- Spherical
- Ellipsoidal
- Planar
- Parabolic Cylinder

SEGMENTED SURFACE

Segments can be any of above analytical surfaces

SLIGHTLY DISTORTED SURFACE

A smooth perturbation of above analytical surfaces characterized by an orderly arrangement of points

ARBITRARY SURFACE

A smooth surface characterized by an unordered arrangement of points

OFFSET PARABOLOIDAL REFLECTOR GEOMETRY

An offset paraboloidal reflector with a focal length of 20.48 cm (8.062 in.) and projected aperture diameter of 24.99 cm (9.84 in.) was fabricated and tested at 35 GHz to verify the computer code for a reflector antenna with an analytically defined surface.

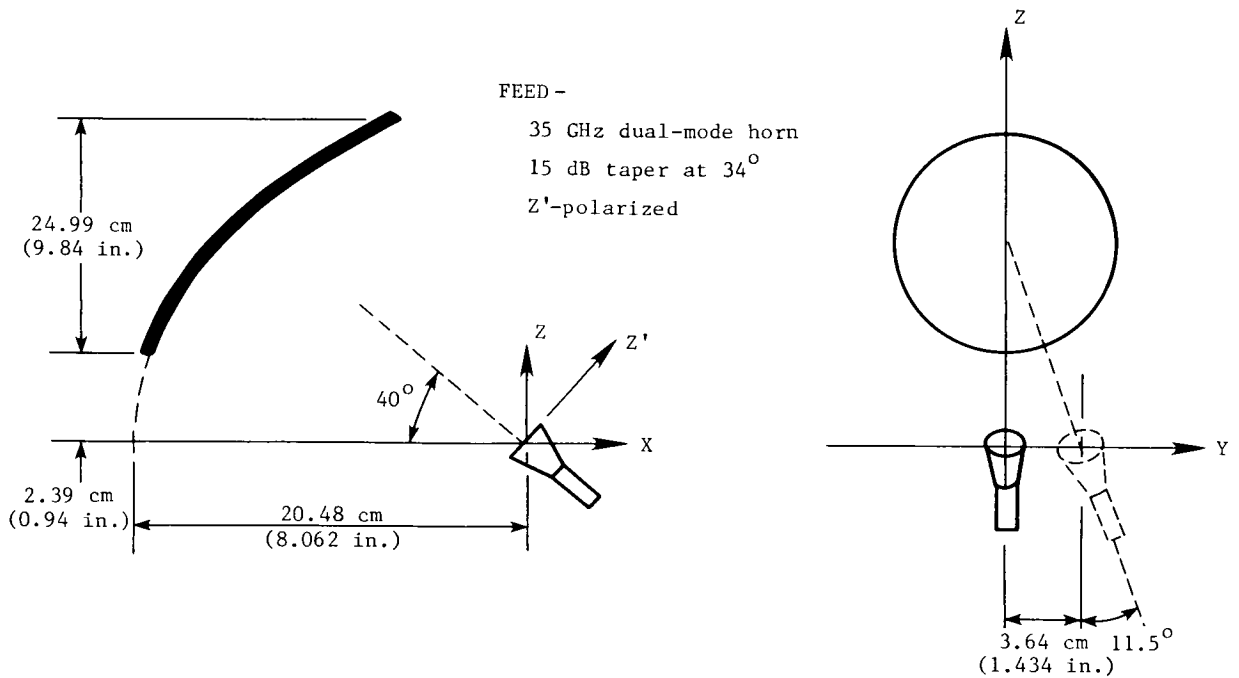

OFFSET PARABOLOIDAL REFLECTOR

The offset paraboloidal reflector is illuminated by a 35 GHz dual-mode horn. The horn is mounted on a 2-axis vernier positioner for precision adjustment of the feed location.

The reflector surface was measured at many points over a rectangular lattice using a 3-axis Validator. The coordinates of selected surface points were used later to verify the computer codes for reflectors characterized by ordered and unordered arrangement of points.

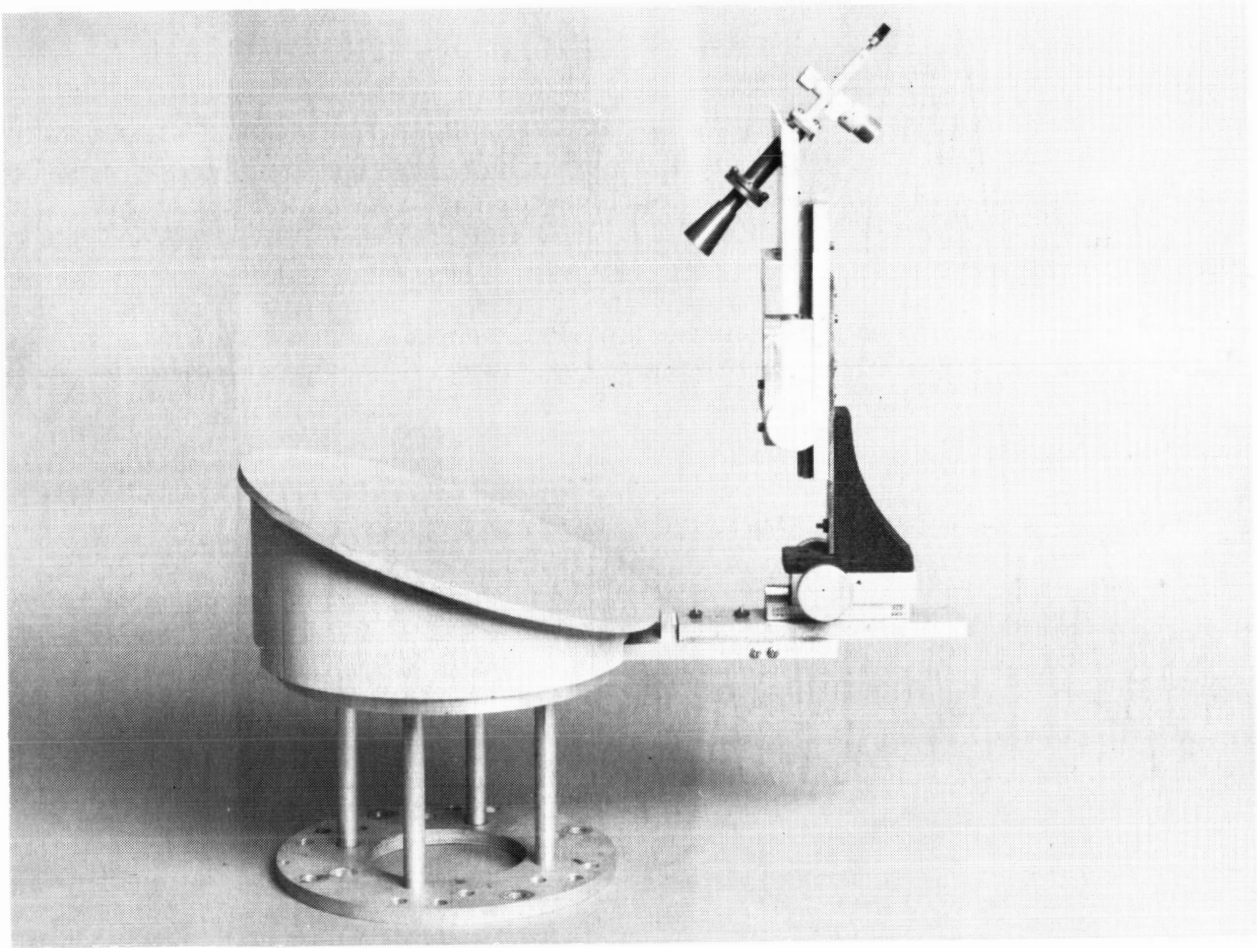

RADIATION PATTERN FOR OFFSET PARABOLOIDAL REFLECTOR

A comparison is made between the measured and calculated radiation pattern in the H-plane (x-y plane) for the offset paraboloidal reflector with the feed horn at the focal point. The calculations were obtained from the computer code for a perfect paraboloidal reflector.

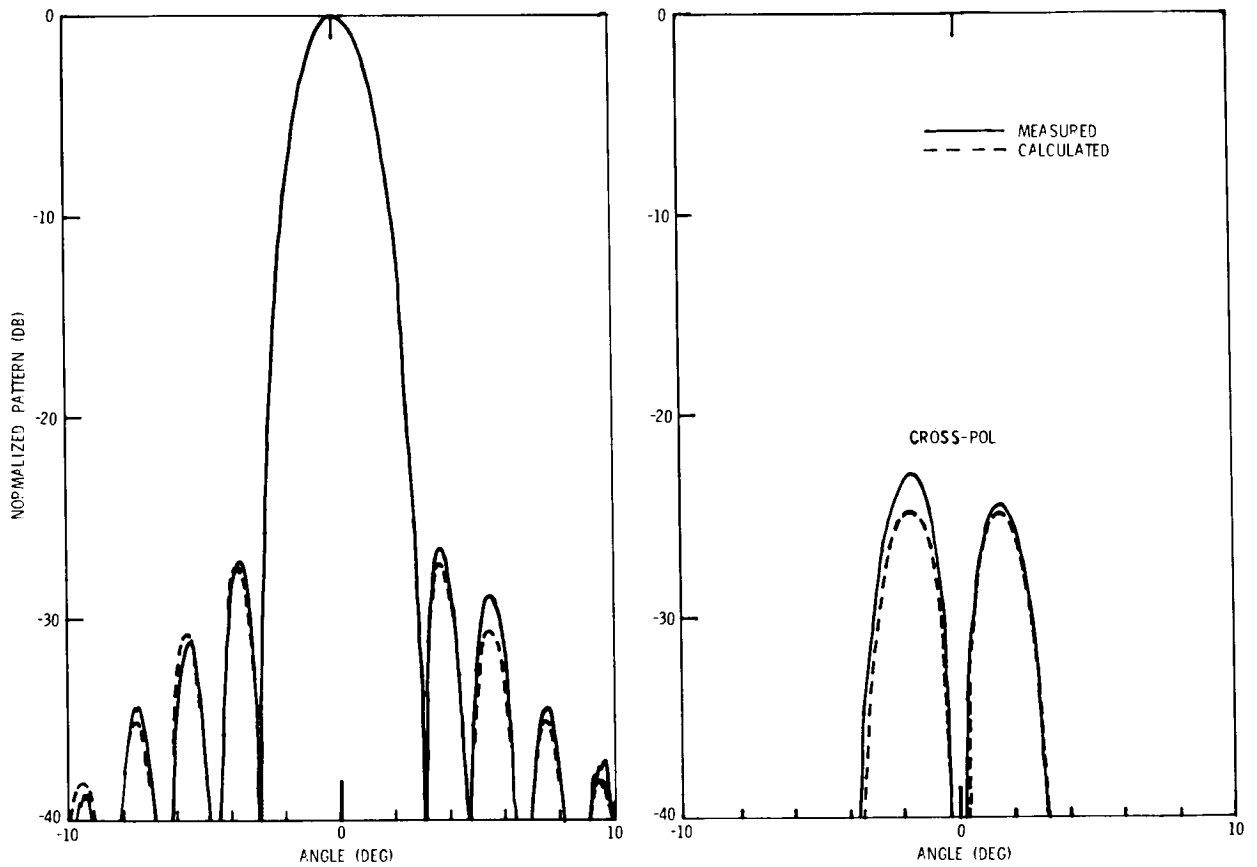

RADIATION PATTERN FOR OFFSET PARABOLOIDAL REFLECTOR (8.5° scan)

Comparison between measured and calculated patterns also verifies the computer code when the feed is laterally displaced for H-plane beam scan.

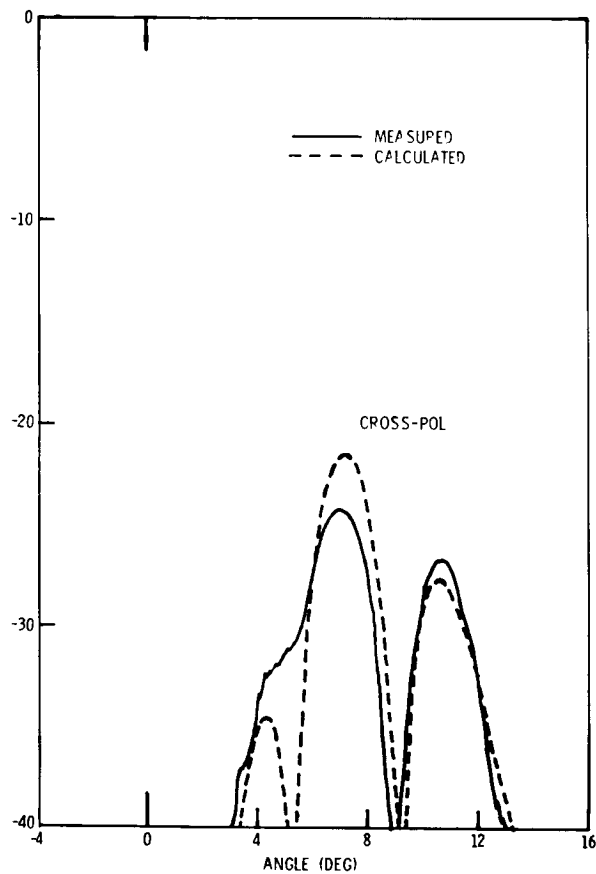
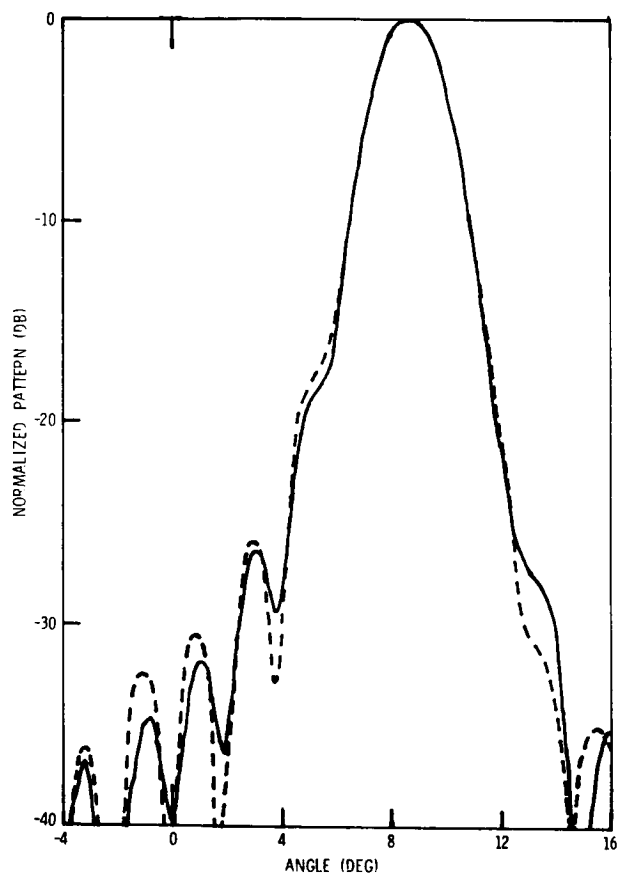

OFFSET FACETED SPHERICAL REFLECTOR GEOMETRY

An offset spherical reflector with a 60.9 cm (24 in.) radius of curvature was fabricated in which the spherical surface is approximated by 54 flat triangular segments. The faceted spherical reflector was illuminated by a 35 GHz dual-mode horn with the electric field vector polarized in the y-direction.

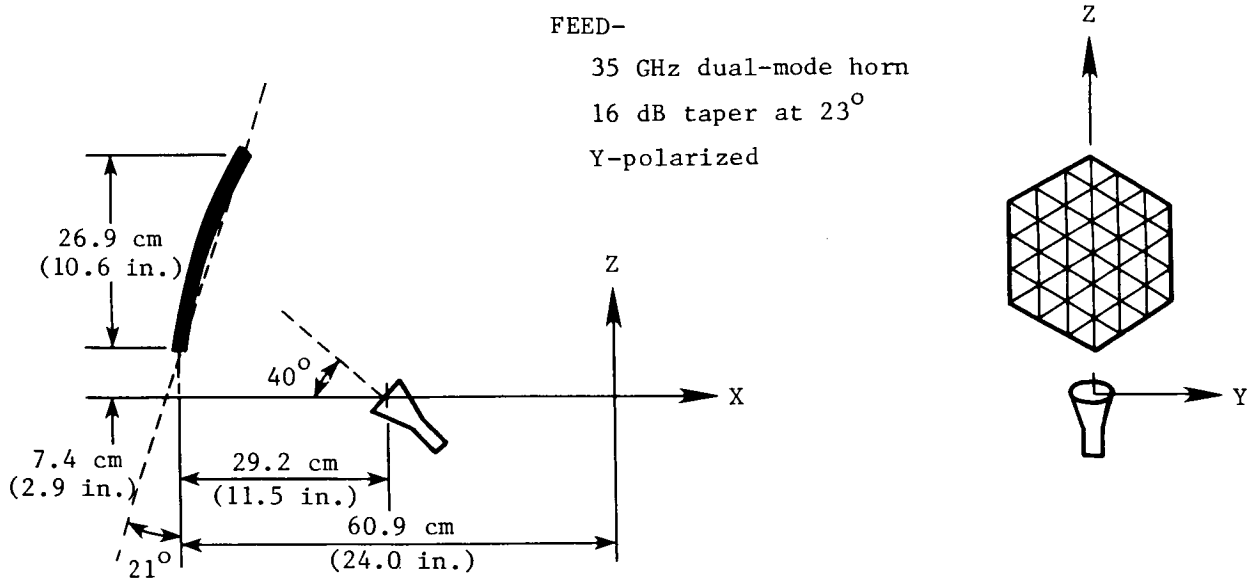

OFFSET FACETED SPHERICAL REFLECTOR

The 35 GHz faceted spherical reflector was used to experimentally verify the segmented reflector computer code for radiation pattern prediction.

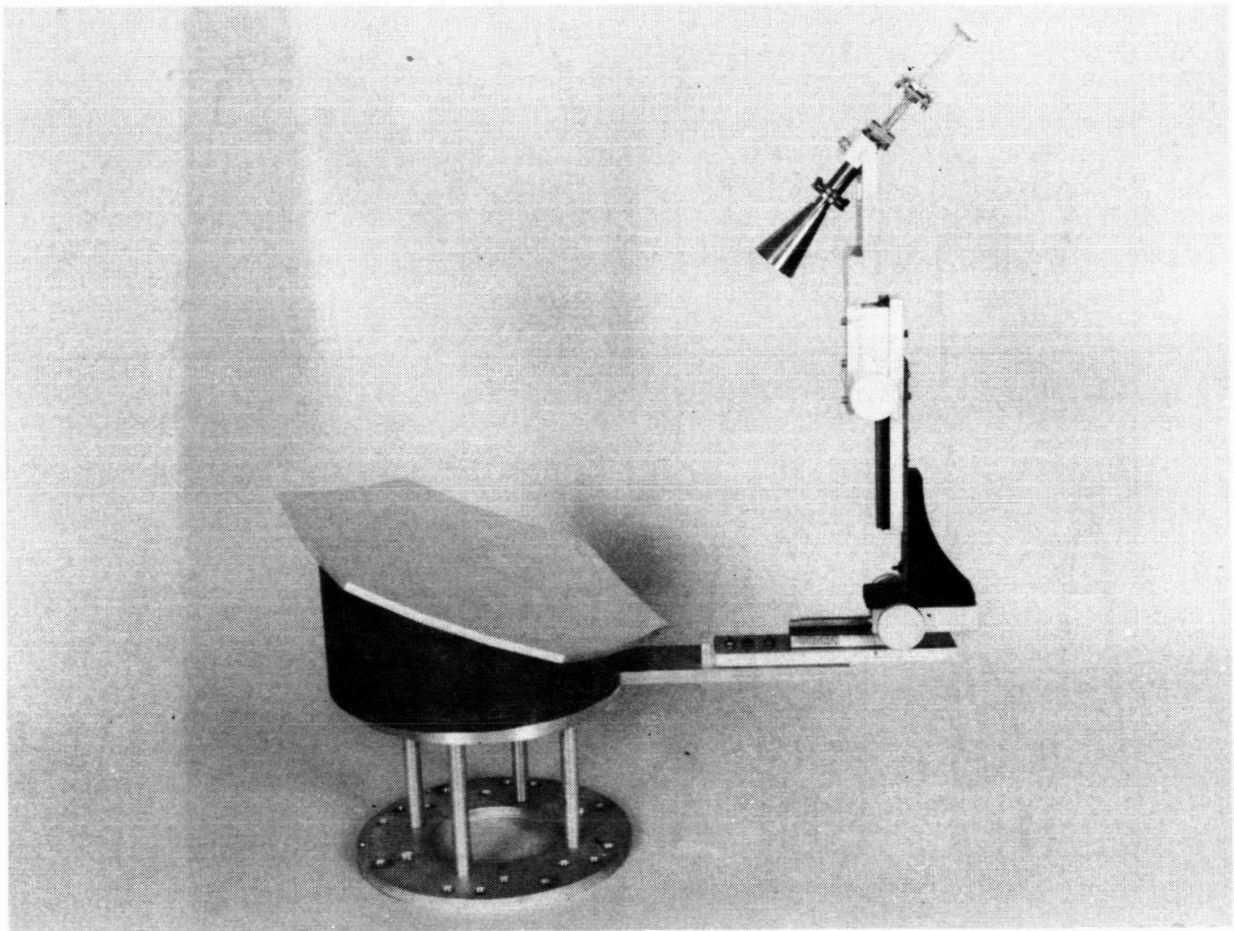

RADIATION PATTERNS FOR OFFSET FACETED SPHERICAL REFLECTOR

A comparison between the E- and H-plane calculated and measured patterns for the 35 GHz faceted spherical reflector verifies the accuracy of the computer code for segmented reflectors. The computer model also accurately predicts the occurrence of a grating lobe effect in one plane due to the periodic nature of the facets.

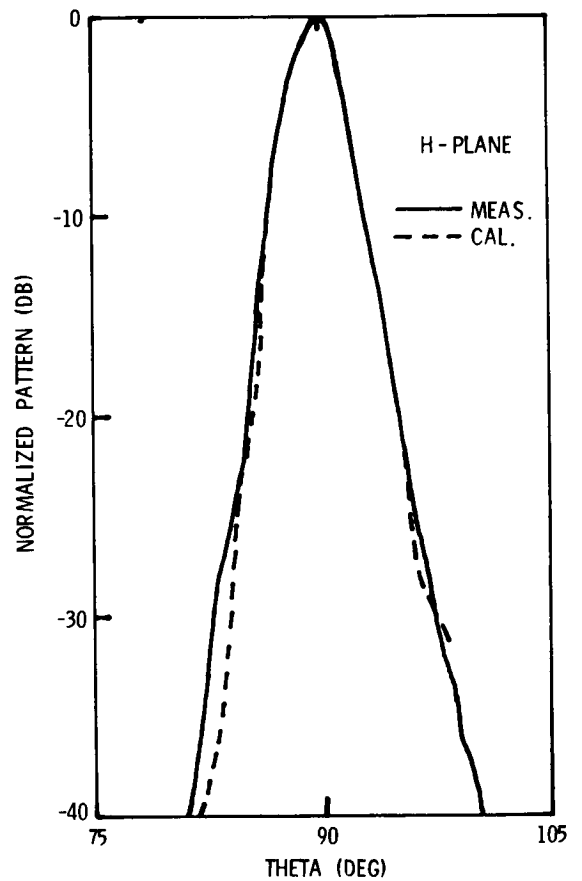
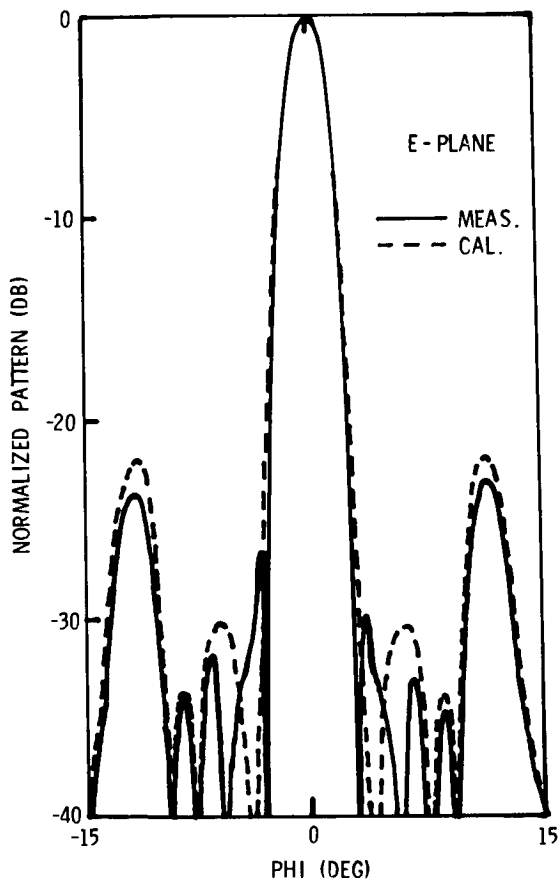

DISTRIBUTION OF POINTS USED TO
CHARACTERIZE SURFACE OF OFFSET REFLECTOR

The surface of the 35 GHz offset paraboloidal reflector was measured at 1844 points. Of these, 200 were selected as shown to be used in the computer code for an arbitrary reflector surface described by a nonuniform arrangement of points. No attempt was made to optimize the number or distribution of points, although 200 was the number selected since that appears to be a realistic number of targets for an in-orbit surface measurement system.

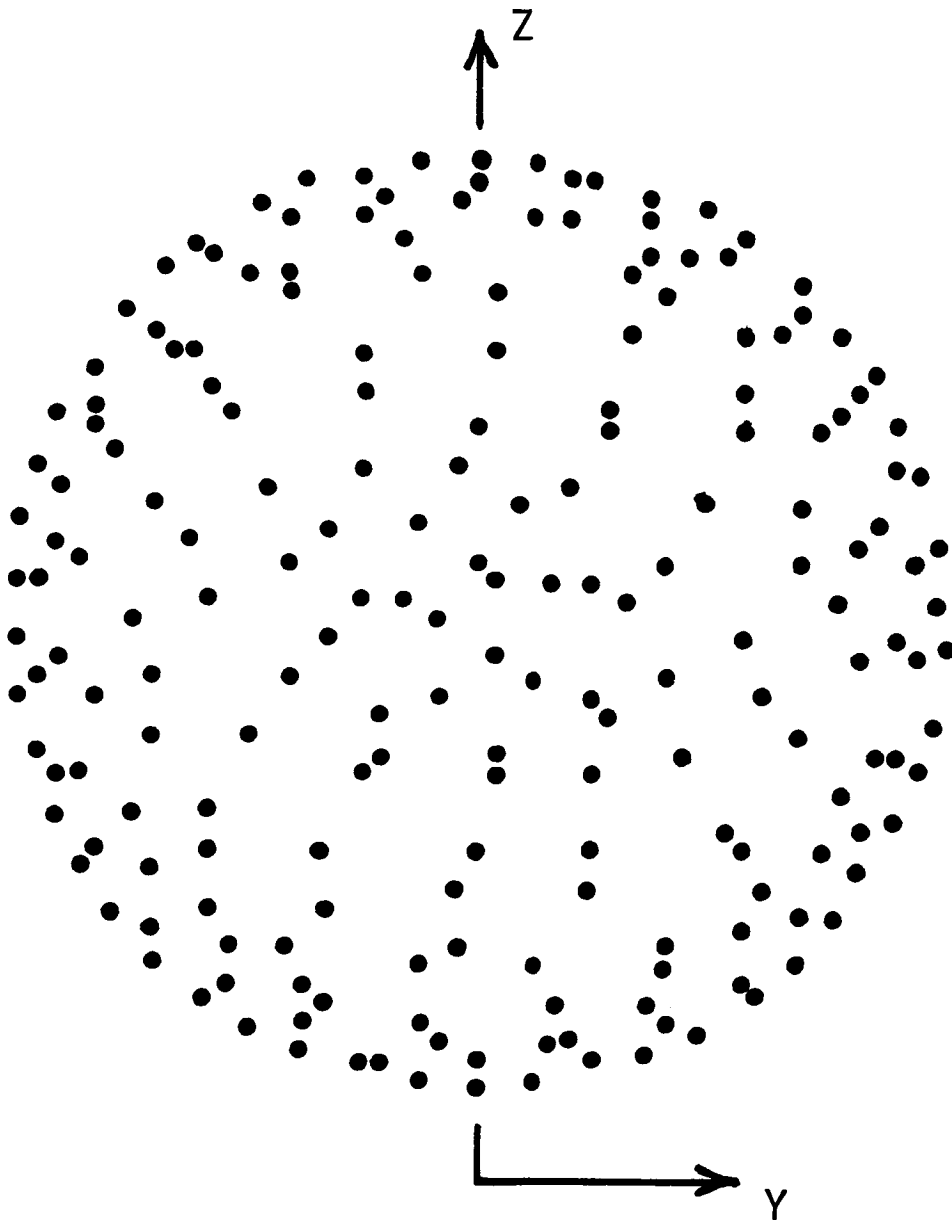

RADIATION PATTERN FOR OFFSET REFLECTOR CHARACTERIZED BY NONUNIFORM DISTRIBUTION OF POINTS

A comparison is made between the measured E- and H- plane patterns of the 35 GHz offset paraboloidal reflector and the calculated patterns for the same reflector using the 200 points to describe the surface. The accuracy of the computer prediction is quite good considering that the only description of the surface was the coordinates of a finite number of points on the reflector. The results indicate the possibility of acceptable accuracy in the prediction of electromagnetic performance for arbitrarily distorted reflectors using the coordinates of a practical number of measured points. An optimization of the number and distribution of points, and experimental verification for a distorted reflector are planned.

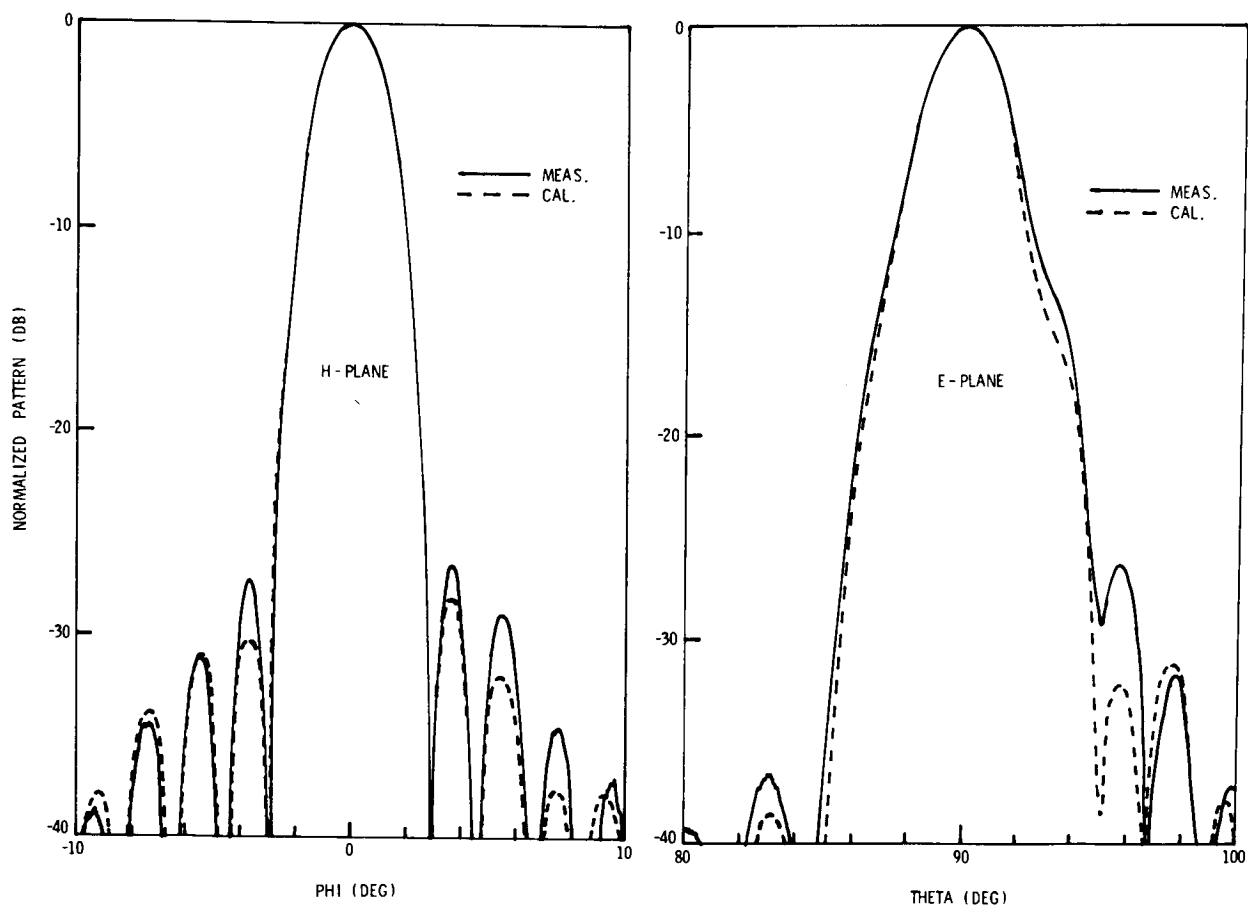

REFLECTOR ANTENNA ANALYSIS
(PLANNED ACTIVITY)

DIFFRACTION EFFECTS

Reflector edges
Objects in aperture (cables, feed, etc.)

DUAL REFLECTORS

Analytically defined surfaces
Surfaces characterized by finite number of points

OPTIMIZATION

Number and distribution of points for characterizing
arbitrary (distorted) reflector surface

EXPERIMENTAL VERIFICATION

Distorted reflector
Dual-reflector