

AUTOMATED INSTALLATION OF
LARGE PLATFORM UTILITIES

R. M. Vernon

LOCKHEED MISSILES & SPACE COMPANY, INC.
Sunnyvale, California

Large Space Systems Technology - 1980
Second Annual Technical Review
November 18-20, 1980

LARGE PLATFORM ASSEMBLER-ORBITER MOUNTED CONFIGURATION

A contractual study of the "Development of Assembly and Joint Concepts for Erectable Space Structures" was undertaken by the Lockheed Missiles & Space Company, Inc., in January, 1979. This study was initiated by the NASA-LaRC and investigated the technology associated with the on-orbit assembly of tetrahedral truss platforms erected of composite tapered, nestable columns. The tetrahedral truss systems incorporate nine-member node joints; two types of these joints were designed and fabricated. Several concepts for assembly were investigated and a preferred concept, the gimballed parallelogram assembler, was developed. This assembly machine design provides fully automatic erection in either orbiter-attached or free-flying modes. For the free-flyer, construction materials (columns and node joints) are unloaded in canisters from the STS Orbiter. The design of machines for assembly of columns ranging in size from 4m to 20m was studied. The smaller machine, mounted on the Orbiter as shown in Figure 1, would be deployable and restowable. Concepts were also developed for STS packaging and transportation of construction materials and the assembler. An assessment of the effects of including non-structural systems in the assembly process was performed, and the effects on design and operation of the automated assembler evaluated. The results of the basic assembler studies are described in Reference 1.

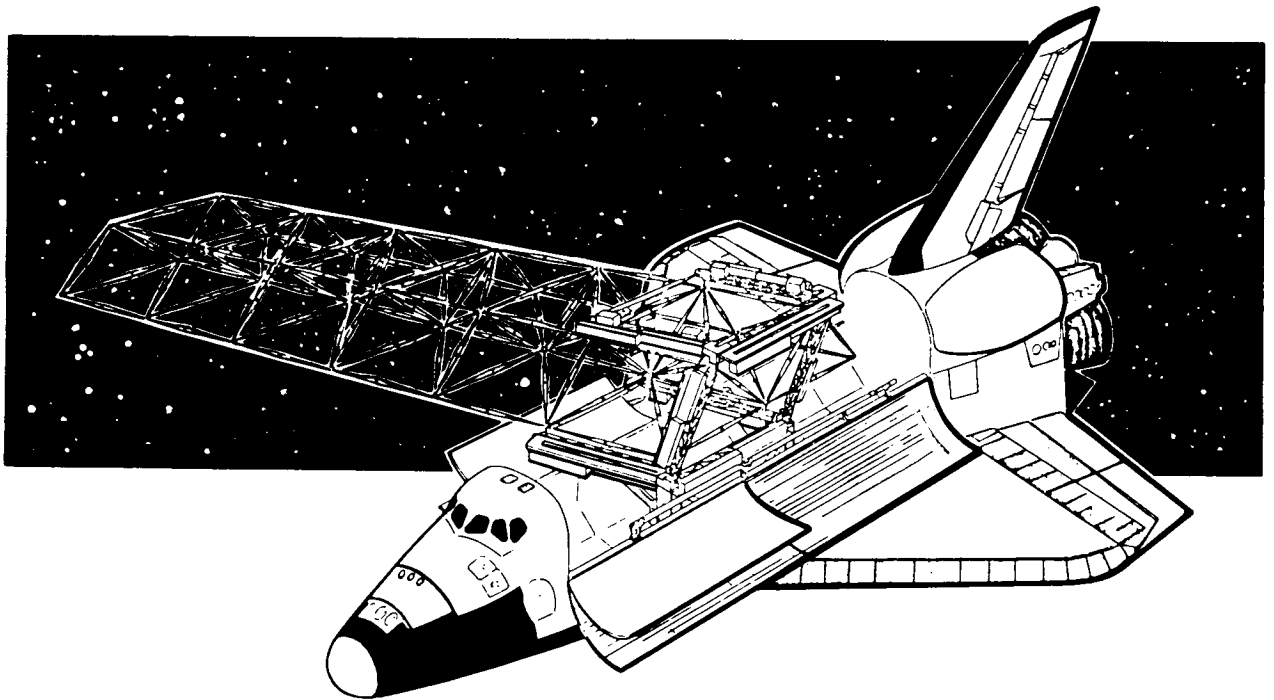

Figure 1

AUTOMATED ASSEMBLER DETAIL

The major structural features of the baseline automated assembler are shown in the figure. This machine is designed to provide rapid assembly of columns and node joints into a variety of platform shapes. It is also inherently reliable, using simple, state-of-the-art mechanisms which perform sequential, repetitive operations. The machine consists of a four-sided main frame having a gimbal joint at each corner. The relative position of the members is controlled by a set of eight actuators which are used to align the frame with the structure being constructed. Two pairs of swing arms, each pair connected by a tie rod, provide for installation of columns in two parallel planes. Supplies of node joints and half-columns are provided in special canisters; node joint canisters are located on the rotating arms, while the half-column canisters are contained in the column storage and assembly packages mounted on one side of each member of the machine. The column assemblers transport completed columns to adjacent column insertion mechanisms which insert the column ends into node joints held by the node retainers. The machine operates by alternately attaching and releasing upper and lower node retainers as it moves from node to node, inserting columns and dispensing node joints as it progresses. In addition to the assembler structure and mechanisms, supporting subsystems are required for maneuver control, electrical power, command and control, data handling and thermal control. For free-flying operation, three additional subsystems are required. These are attitude control, communications, and, for long-life missions, propulsion and reaction control.

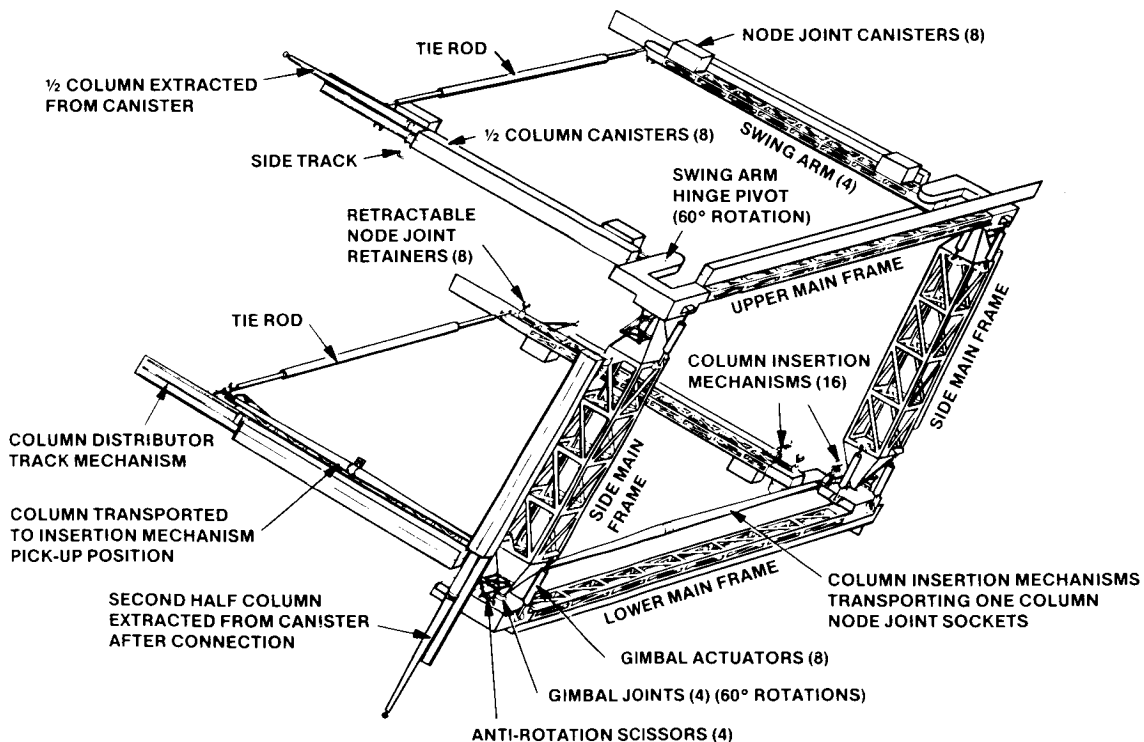

Figure 2

SPACE PLATFORM GEOMETRY

The tetrahedral truss acts as a space platform on which a variety of components and equipment can be mounted. This truss is erected from tapered, composite half-columns which are coupled at their large ends to form full columns. A key feature of this truss is the nine-point node joint. These joints are identical, and each provides nine receptacles for installation of column end-fittings. A typical arrangement of an assembled space platform is shown schematically in Figure 3. The dimensions shown are based on a 4m column length. The upper surface of the platform is shown by the heavy solid lines, representing individual columns, and the filled circles which indicate node joints. The lower face of the platform is represented by the light solid lines and open circles. The dashed lines are core columns connecting the upper and lower platform faces. In general, core columns will have different dimensions than face columns. Platform planforms which can be constructed with the replicated tetrahedral structure include equilateral triangles, hexagons, rectangles, and a linear truss as shown in the figure. In addition, the basic structure can be used to generate hexagonal toroidal platforms, spherical surface segments and, of course, large area platforms.

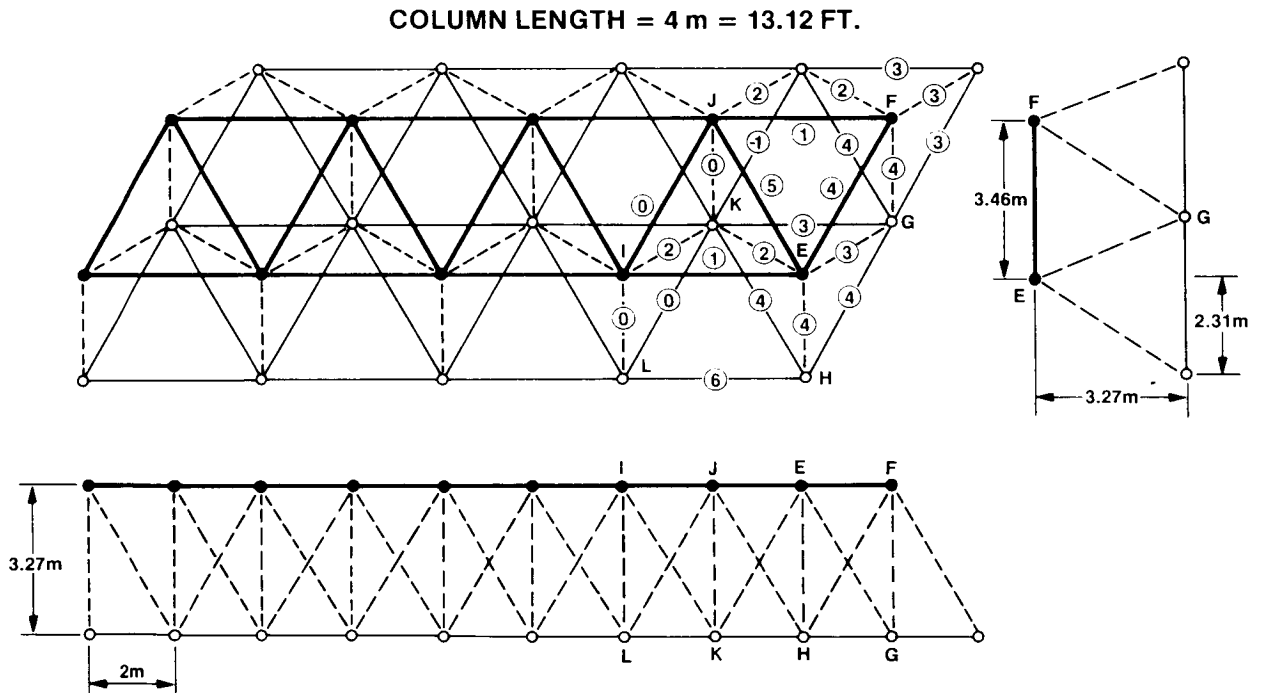

Figure 3

ASSEMBLER OPERATION

As shown in Figure 4, the assembler is attached to the platform under construction by the node joint retainers; the machine maneuvers by releasing one or two pairs of node joints, rotating about the stationary joints, and capturing new pairs of node joints. In order to provide platform control, a maximum of four node joints can be released simultaneously. The assembler can then maneuver either laterally, forward or backward about the four held joints, inserting from one to eight columns at a time. Since the assembler is always outside the envelope of the platform being assembled, columns can be assembled and inserted simultaneously, thus minimizing construction time.

The assembler can utilize a variety of maneuver sequences depending on the shape of the platform being constructed. In constructing a large area platform, for example, the assembler advances along the edge of the platform by alternately swinging its arms about the two upper gimbals (rotation γ) and then about the two lower gimbals. Figure 4 illustrates the construction sequence for building a linear platform. The platform shown here has the minimum section which can be built by the assembler. The construction sequence consists of six steps per cycle during which 17 columns are inserted to advance the platform by one column length. The columns which are installed at each step are shown by the circled numbers. Note that steps 5 and 6 can be performed simultaneously, so that the 17 column cycle can be completed in 10.5 minutes, and a 2700 column shuttle load assembled in 27.8 hours.

STEPS 5 AND 6 CAN BE PERFORMED SIMULTANEOUSLY
SEVENTEEN 2M COLUMNS CAN BE INSERTED IN APPROXIMATELY 10.5 MIN
STD. 2700 COLUMN LOAD IN 27.8 HR.

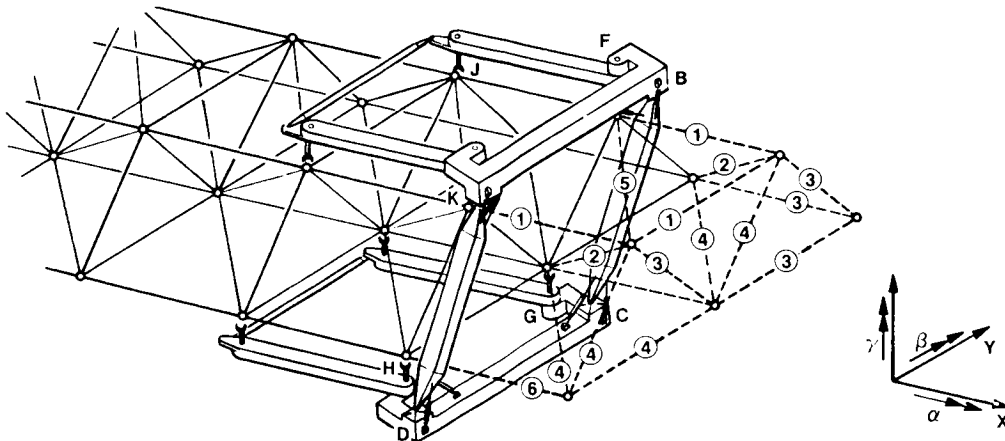

STEP	ROTAT.	ABOUT	NO. COL.	ROT. TIM. MIN.	COL. INS. MIN.
1	β	C&D	3	1	1
2	α	A&B	2	1	1
3	β	A&B	5	1	1.25
4	α	A&B	5	1	1.25
5	γ	E&F	1	1	1
6	γ	H&G	1	1	1
TOTAL			17	6	6.5

Figure 4

SNAP LOCK NODE JOINT

Several node joint concepts have been derived for tetrahedral truss structures; one of these is shown in Figure 5. The joint is designed so that the column end fittings (having the sprocket-like toothed heads) are inserted laterally into the joint. The teeth on the end fitting are designed to engage a pin in the node-joint receptacle, thereby locking the column against torsion. During the assembly sequence, as the end fitting is guided into place it trips a cam latch which swings down to grasp the column end fitting. A spring-loaded locking finger drives itself along one of the cam surfaces, securing the latch in its locked position. Tests with the fabricated joint show that insertion can be performed with minimum effort and that the joint offers good rigidity in the locked configuration.

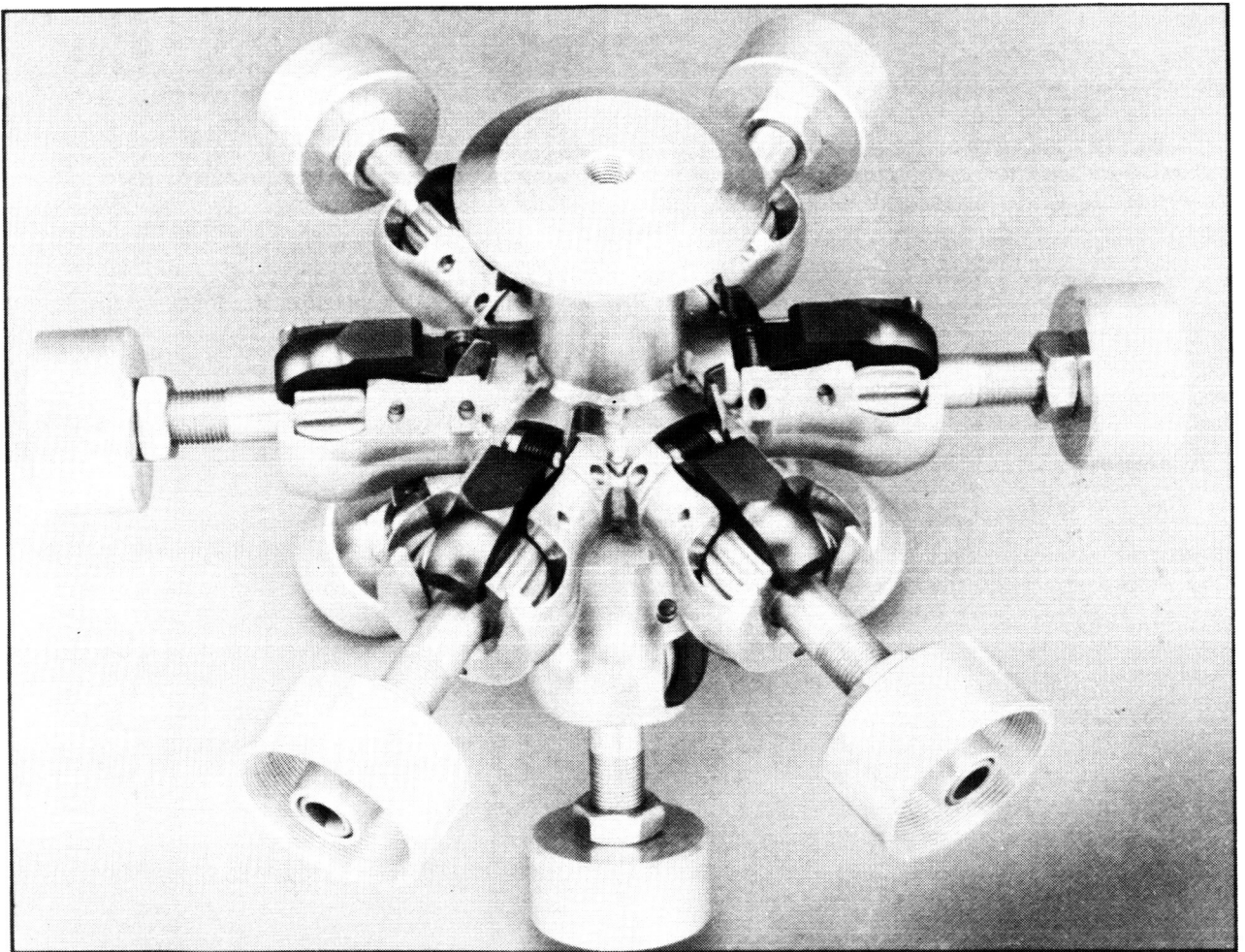
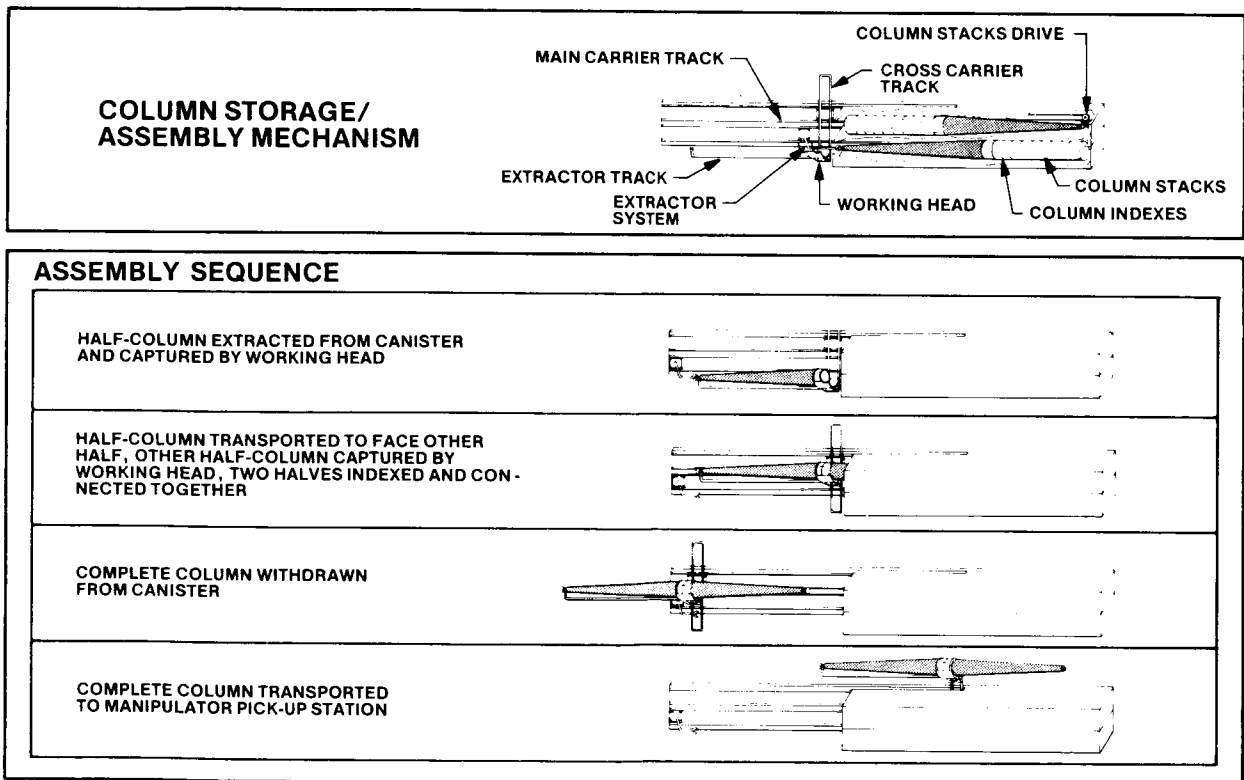

Figure 5

COLUMN STORAGE AND ASSEMBLY

A candidate design concept for column storage and assembly is shown in Figure 6. This half-column assembly machine consists essentially of a tracked column carrier and a double canister which contains two stacks of nested half-columns stored in opposite directions. The canisters are equipped with a driving mechanism designed to advance the column stacks one step at a time. This advance mechanism can be powered from the carrier track via a simple clutch system.

The carrier mechanism performs all the functions required to assemble and transport the half-columns to a position where they can be captured by the insertion mechanisms. The sequence of operation is shown in the figure. Designs for the working head, node retainers, node supply and column insertion mechanisms have also been developed in sufficient detail to verify concept feasibility.



BASELINE ASSEMBLER CAPABILITIES

Several features of the automatic assembler are summarized in Figure 7. As described earlier, the assembler can be adapted to operation in a free-flying or an Orbiter-mounted mode. In the latter case, rail-mounted operation can be used to minimize forces imposed on the Orbiter due to assembler maneuvers. Programming the assembler to construct various platform geometries is expected to require only software changes, except for the use of special column canisters for unequal length core and face columns such as would be used to generate spherical surfaces. It is estimated that the automatic assembler would be capable of assembling a shuttle load of 20-m columns in about 36 hours (free-flying mode). This estimate consists of eight hours for loading the assembler and 28 hours of actual construction time. The resulting platform would have an area of 0.1 sq km. For Orbiter-mounted operation, smaller platforms would be built with more complex interactions and interfaces with the STS. In addition to the availability of astronaut support by EVA, data handling, maneuver control and electrical power can be provided to the assembler by umbilical connections to the Orbiter.

ASSEMBLY MODES

- ORBITER MOUNTED
- FREE FLYING

ASSEMBLY PROGRAMMING

- VARIED SHAPES/SIZES
 - LINEAR TRUSS
 - LARGE AREA PLATFORMS
 - HEXAGONAL TORUS
 - SPHERICAL SURFACE
- ENLARGE/MODIFY STRUCTURES

CONSTRUCTION TIME

- 1.5 DAYS PER SHUTTLE LOAD

INTERFACES

- STS TRANSPORT
- AUTOMATIC MAIN-FRAME DEPLOYMENT, UTILITY INTERCONNECT
- ASSEMBLY UNDER PROGRAM OR ASTRONAUT CONTROL
- ASSEMBLER RAIL MOUNT FOR LARGE STRUCTURES
- COLLAPSE/STOW WITH EVA ASSIST

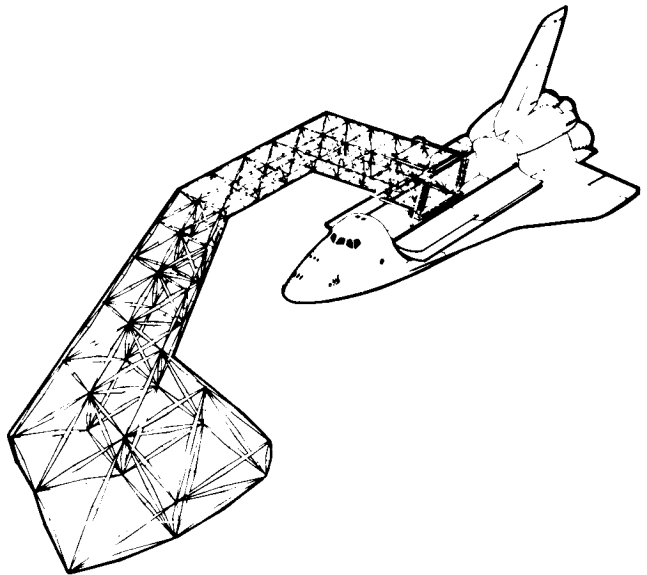

Figure 7

AUTOMATED UTILITIES INSTALLATION

A major task in this study was the assessment of capabilities of the assembler in installing non-structural platform systems. These systems include electrical power distribution, heat transport, command and data signal transmission, and payload data transmission. The objectives of this effort were to evaluate the effects of including installation of utilities on the assembly process and on the design, operation and performance of the assembler. In addition, any special requirements on the assembler and/or the platform due to the installation of utilities were to be identified. The chart shown in Figure 8 lists these objectives, as well as the guidelines followed in this task. The procedure followed was to define a set of candidate utility characteristics and installation requirements, define and design installation concepts, and perform an assessment of impacts on the assembler and its operation.

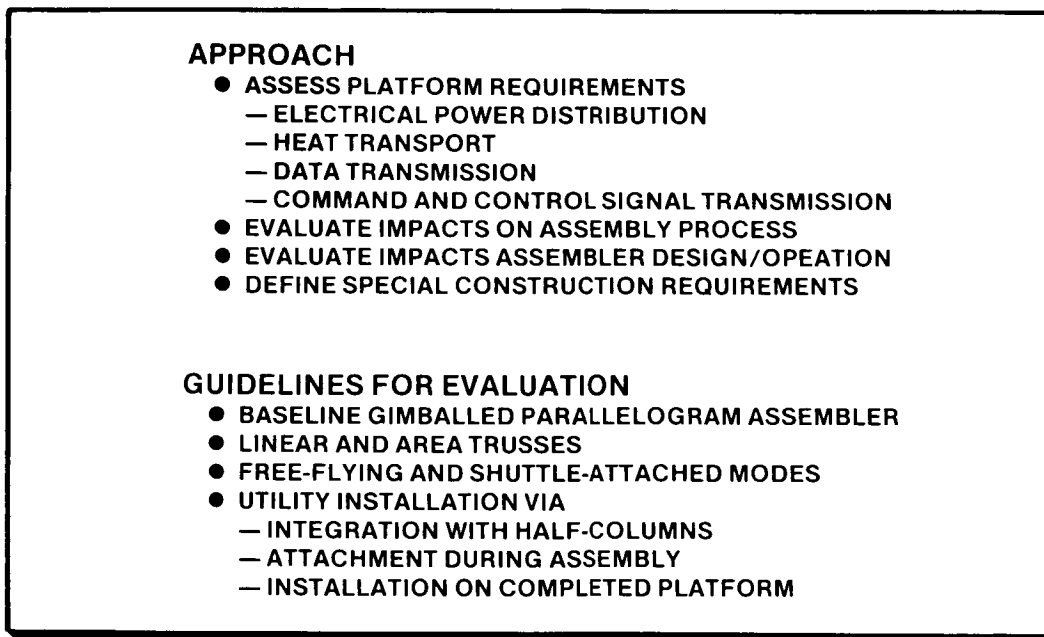

Figure 8

BASELINE UTILITIES REQUIREMENTS

Candidate utilities considered in this task included those required for the following:

- o Electrical power distribution
- o Heat transport
- o Data transmission
- o Command and control signal transmission

Basic requirements for the distribution of these utilities were derived using published descriptions of space platform concept designs, as exemplified by References 2 and 3. In general, the larger platforms require larger total power and benefit most from high voltage distribution systems. A breakdown of utility distribution systems for four reference platforms (Rockwell P-1, MDAC A/B, SASP and ASASP) was constructed. From this summary, it was found that wire sizes for power distribution were much larger than those for data and signal transmission. Therefore, attention was directed toward requirements for power and coolant distribution, and definition of a baseline set of near-term requirements and an alternative set of requirements for an advanced platform. These requirements are summarized in Figure 9. Baseline power distribution was to be obtained in both the near-term and advanced platforms by the use of No. 4 AWG cables. The most stringent requirement for coolant distribution was that for the near-term platform, where 20 mm-diameter tubing was required.

PLATFORMS: NAR P-1, MDAC A/B, H, SASP-A, B, C, ASASP
DC LOADS: 5 TO 33.kW, 29 TO 168 V

FUNCTION	UTILITY REQUIREMENT	
	NEAR TERM	ADVANCED
POWER	NINE NO. 4 AWG WIRES OR FLAT CABLE, 0.020 IN. THICK	THIRTEEN NO. 4 AWG WIRES
DATA AND COMMUNICATIONS	FOUR R6143 COAX LINES	10 CHANNEL FIBER OPTIC LINE
COMMAND AND CONTROL	FOUR NO. 12 TSP LINES	FOUR NO. 12 TSP LINES
THERMAL CONTROL	PUMPED-FLUID HEAT PIPES OR FOUR 2 C-M DIA STEEL TUBES	LOCALIZED AT P/L MODULES

Figure 9 (Note: 1 in. = 2.54 cm.)

WIRE BUNDLE ARRANGEMENTS

For the purpose of this study, the electric cable configuration was assumed to consist of the following wires:

9 #4 AWG + 4 RG 143 coax + 4 #12 TSP lines

A bundle thus consists of 17 wires which may be organized either within a circular or a flat pattern (Fig. 10). The circular pattern can be used either with reel storage or as cable segments designed for straight storage in canisters either separately or with the half-columns. The flat pattern is designed to allow easy bending over reels, in which case a special device must be provided to straighten the cable before it is laid along the structure. A preliminary investigation indicates that the baseline set of cables will require a #40 connector shell which has a diameter of 59 mm. The connector nut is somewhat larger (~70 mm). The flat bundle concept may have multi-branches with connectors if reel stowage permits. A 1-m diameter reel having a .30-m core diameter will contain approximately 80 m of cable in the case where only the end connectors are needed. Multispool stowage will make it possible to provide within a single canister a continuous length of cable in multiples of 80 m. The round cable bundles may be stowed in reels or in linear canisters, either as a part of the half-column canisters or as separate specialized canisters. In this case, the cables are laid straight, each one in a tubular compartment of the length of the half-column canister. The cables are extracted from the canister at the time of column assembly and attached to the column.

CABLE CONNECTOR ARRANGEMENT IN STANDARD NO. 40 SHELL

- 1 9.5 DIA. GROUND AT CENTER
- 4 9.5 DIA. CO-AX ON 0.934 DIA.
- 8 9.5 DIA. NO. 4 ON 1.754 DIA.
- 4 4.8 DIA. NO. 12

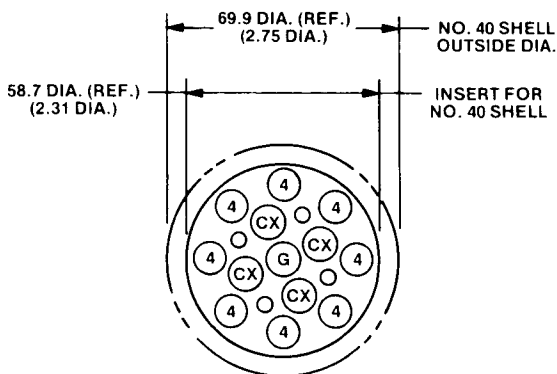

WIRE BUNDLE ARRANGEMENTS

- ALL INCLUDE: 1 7.1 DIA. GROUND
- 4 7.1 DIA. CO-AX
- 8 7.1 DIA. NO. 4
- 4 3.1 DIA. NO. 12

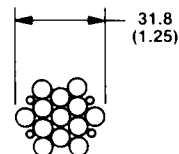
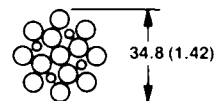
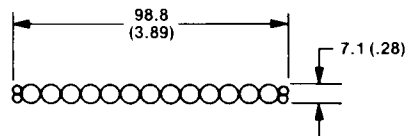

Figure 10

TUBING CONFIGURATIONS

Several types of tubing design and material were considered:

1. Thin wall tubing - aluminum, stainless steel, graphite epoxy
2. Thin wall lenticular tubing - stainless steel, graphite epoxy
3. Inflatable - self-curing fiberglass tubing
4. Inflatable - fiberglass reinforced plastic tubing

They are shown schematically on Fig. 11. Tubing type 1 is a standard design needing no special development. Tubing type 2 consists of two thin metallic plates bent to a sinusoidal cross section and continuously welded together to a lenticular shape. This tubing is not capable of carrying high pressures due to high stresses at the welds, but it can be flattened out and rolled around a drum in a tight package of great deployed length. Tubing type 3 consists of a fiberglass tube bonded inside plastic tubing. The fiberglass is impregnated with an epoxy resin and will remain pliable until such time as a catalyst is brought in contact with it. In this condition, a considerable length of tubing can be flattened and wound on a spool in a very tight package. After the flattened hose has been laid-up and all connections secured, it is inflated with the catalyst, allowed to cure, vented and flushed with compressed air. Tubing type 4 is a continuous plastic tube reinforced by a braided fiberglass casing bonded with a flexible agent. Such a tubing could be flattened to be wound over a drum or reel and dispensed in the same manner as tubing No. 3.

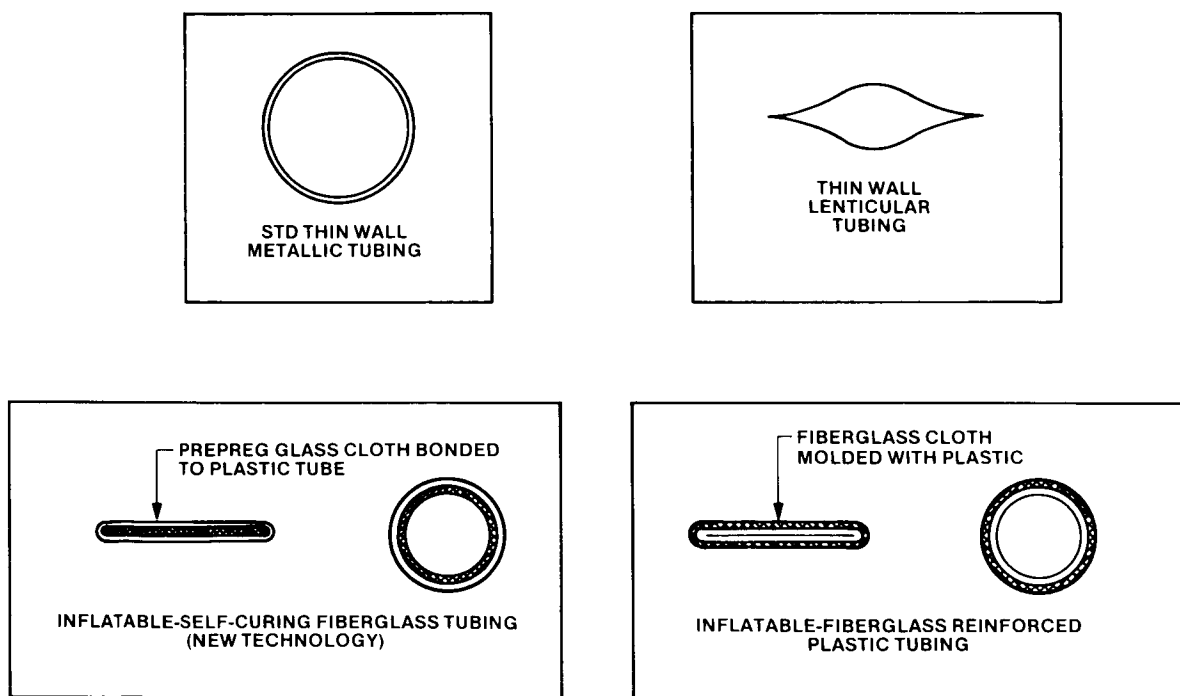

Figure 11

CABLE LAYING CONCEPT

Two basic cable storage concepts were considered: reel storage and segmented storage. Segmented storage refers to storage of individual segments of cable in lengths approximating the half-column lengths. The general arrangement of the reel storage and dispensing concept is shown in Figure 12. In general, the reel dispensers would be mounted as required at individual corners of the assembler to facilitate laying cable on either platform surface and in left- or right-hand traverses. Since the assembler has the ability to perform changes in the direction of traverses along any one of the three sides of the basic tetrahedral triangle, this property can be used to lay utilities along specified paths of the platform structure. By proper programming of the construction sequence, the partially assembled platform can have, temporarily, a free edge along the required utilities path such that the assembler can perform a cable-laying traverse. This traverse could include a number of changes of direction and would be conducted at the same time as columns are being inserted. Intersecting utility paths can be accommodated if a junction box is placed at their intersection.

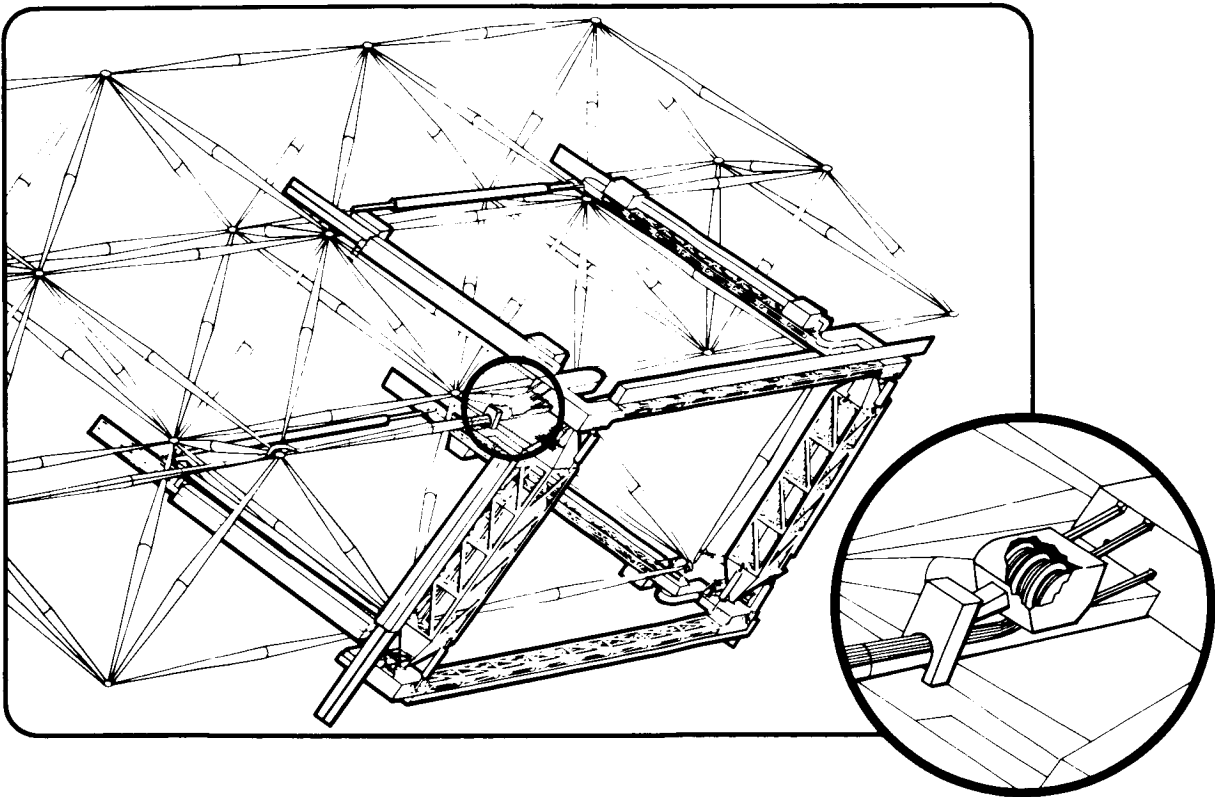

Figure 12

CABLE LAYING MECHANISM

The reel-type cable laying mechanism consists of a canister containing the cable wound continuously over one or several spools (about 80 m of flat cable per spool) and a cable guide unit which performs three additional functions: pulling the cable from the spool, straightening it, and binding it to the column. This complete system is mounted on four swinging arms which provide the necessary freedom to follow the column's surface while the assembler moves. Figure 13 shows the assembler at mid-course during a right-hand traverse between two node joints. At this point, the node joint retainer is approximately 3 m above the retainer level but the cable laying unit remains level with the columns. In the alternate traverse, the assembler swings in the plane of the platform and the cable laying unit uses its other degree of freedom to follow its track. The true motion of the cable laying unit is somewhat more complicated due to the geometry of the platform structure and requires combined motion of both degrees of freedom for one repetitive cycle of each traverse (See Ref. 1 for a description of the traversing motion). A preliminary estimate was made of the capacity of candidate reel storage designs. This estimate indicates that the round cable configuration shown in Fig. 10 could be stored in continuous lengths of about 700 m per meter width of drum, while the flat cable configuration would not allow more than about 500 m on the same drum width. On this basis, the round cable would appear preferable.

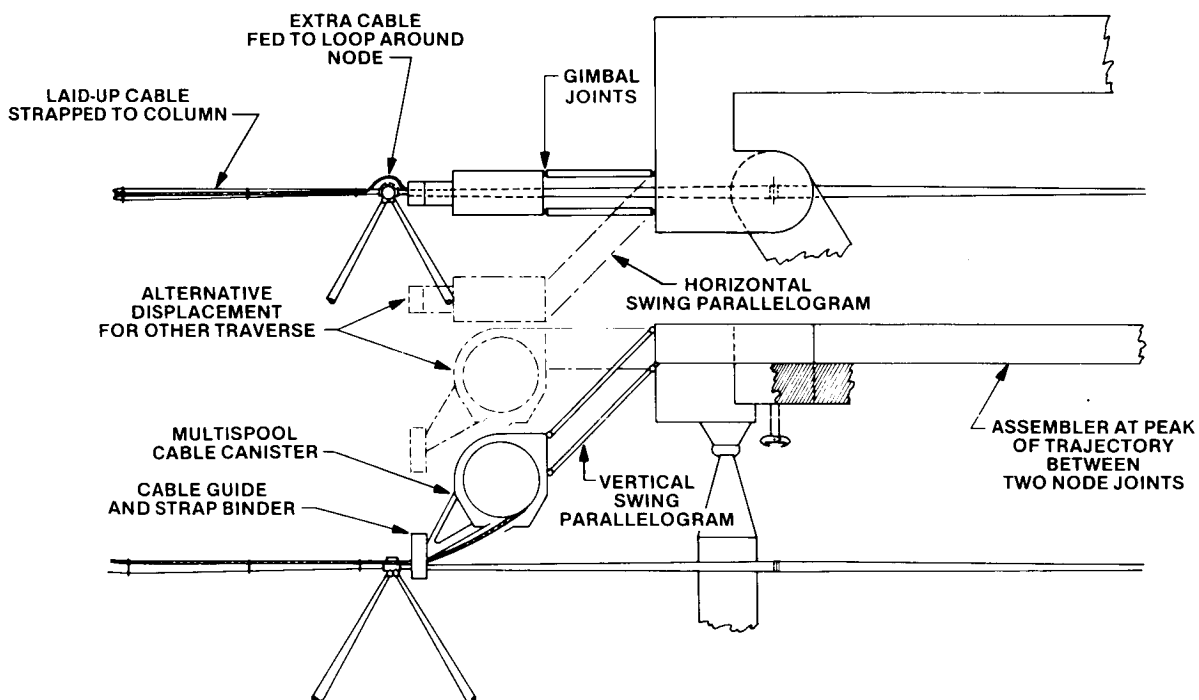

Figure 13

INSTALLATION OF SEGMENTED UTILITIES

Figure 14 shows a conceptual design for segmented cable storage in the column canisters.

With this design, the installation of cable segments is accomplished concurrently with the assembly of the half-columns. Each cable segment is individually stowed in a thin wall tube from which it is extracted by the half-column extractor system suitably modified to perform this additional function. An automatic binder attaches the cable to the first half-column. Then, as the completed column is withdrawn from the canister, additional straps are automatically placed at intervals on the other half-column. Thus, the column plus attached cable can be transported by the carrier system to the manipulator pick-up points.

Although this segmented cable installation system can be mounted on anyone of the eight arms of the platform assembler, its primary utility is on the two vertical members of the assembler, where it can be used to install cables on core columns.

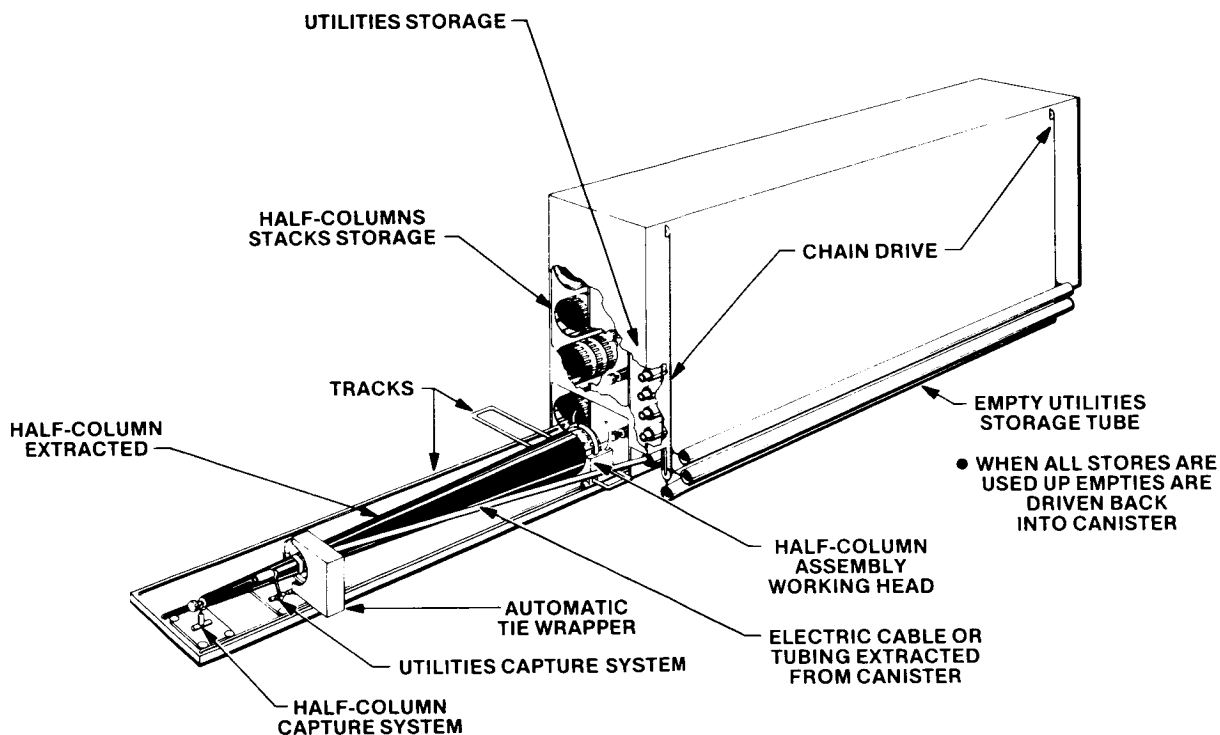

Figure 14

ASSEMBLER DESIGN AND PERFORMANCE IMPACTS

The results of this study show that concept designs for utilities installation are available which have relatively little impact on assembler design. By storing and dispensing cables or tubing on reels or drums, a separate set of mechanisms can be used which can be attached as needed to the basic assembler structure. Similarly, for the installation of segmented utilities, a separate canister can be integrated with the column canister. Column assembler and utility installation can then be performed in parallel.

In assessing operational and performance impacts, it was found that the magnitude of these impacts depended on whether utilities installation was performed concurrent with or in series with the platform assembly process. If utilities are required to be installed around the periphery of a completed platform, the operations can be performed serially. In this case, the utilities installation time is additive to that for platform assembly and is minimal. A greater impact is observed if utilities are installed in parallel with platform assembly operations. In this case, two primary impacts are foreseen. One of these is a reduction in the area of a platform which can be constructed from a single STS load of materials; this area reduction is due to the added space required in the Orbiter for carrying utilities. As shown in Fig. 15, this effect is small for utilities installation across and around the periphery of a platform, ranging from 1% to 4% decrease in area. However, a large impact on construction time is observed, with estimated increases of from 23% to 34%. The absolute values of construction times with utilities for the example shown range from 48 to 69 hours.

ASSEMBLER DESIGN

- MINIMAL HARDWARE DESIGN IMPACT
 - REEL-WOUND UTILITIES USE DEDICATED MECHANISM
 - CANISTER FOR SEGMENTED UTILITIES INTEGRATED WITH COLUMN CANISTER
- ADDED SOFTWARE

ASSEMBLER OPERATION/PERFORMANCE

- UTILITY INSTALLATION EITHER CONCURRENT WITH OR SEPARATE FROM PRIMARY ASSEMBLY PROCESS
- ADDITION OF UTILITY INSTALLATION
 - INCREASES OVERALL ASSEMBLY TIME
 - REDUCES AREA OF PLATFORM WHICH CAN BE BUILT FROM A SINGLE STS LOAD

COLUMN LENGTH (m)	NUMBER OF COLUMNS PER STS LOAD *	PLATFORM AREA WITHOUT UTILITIES (m ²)	WITH UTILITIES ADDED	
			AREA CHANGE (%)	CONSTRUCTION TIME CHANGE (%)
4	4,200/4,158	6.5 x 10 ³	-1	+23
10	3,000/2,940	2.9 x 10 ⁴	-2	+30
20	2,700/2,592	1.0 x 10 ⁵	-4	+34

* WITHOUT UTILITIES/WITH UTILITIES

Figure 15

UTILITY INSTALLATION SUMMARY

The studies performed on assembler utility installation have resulted in the conclusions summarized below. The installation of candidate utilities can be implemented using existing state-of-the-art technology by adding on devices or modifying the baseline assembler design. Proper programming of utility installation allows for compatible assembly operational sequences for a variety of platform sizes and shapes, with minimal impact on assembler design and operation. The study results also show that a postulated utilities network installation on candidate platforms requires little Orbiter payload bay volume and thus imposes only a small reduction in the size of the platform which can be produced from a single STS load. However, the amount of total construction time required can be increased significantly, depending on the extent of the required utilities. In addition, the complexity and development requirements of automated connection devices makes it desirable to use astronaut EVA to perform utilities hookup tasks.

This study has resulted in the identification of feasible designs for storage and dispensing of cables and tubing by two means: continuous reels or segment dispensers. Existing devices for cable binding can be adapted to perform this task automatically during utility installation. Finally, an investigation of the use of column-integrated conductors in composite columns has shown that this approach requires considerable manufacturing technology development and is not practical with current materials and column designs.

- **ASSEMBLER UTILITY INSTALLATION:**
 - USES EXISTING TECHNOLOGY
 - IS COMPATIBLE WITH ASSEMBLY SEQUENCES
 - IS ADAPTABLE TO RANGE OF PLATFORM SIZES, SHAPES
 - HAS MINIMAL IMPACT ON ASSEMBLER DESIGN, OPERATION
 - HAS NEGLIGIBLE EFFECT ON AREA OF PLATFORM ASSEMBLED PER STS LOAD
 - INCURS AN INCREASE IN ASSEMBLY TIME IN PROPORTION TO AMOUNT AND LOCATION OF UTILITIES
 - REQUIRES EVA FOR COUPLING, CONNECTIONS

- **APPLICABLE DESIGNS AND MECHANISMS INCLUDE:**
 - REEL STORAGE AND DISPENSING
 - CANISTER STORAGE
 - BINDING MECHANISMS

- **COLUMN-INTEGRATED CONDUCTORS ARE IMPRACTICAL AND DIFFICULT TO IMPLEMENT**

Figure 16

REFERENCES

1. G. G. Jacquemin, R. M. Bluck, G. H. Grotbeck, and R. R. Johnson: "Development of Assembly and Joint Concepts for Erectable Space Structures," NASA CR-3131 (to be published).
2. K. A. Bloom, "Space Construction and Utility Distribution," Large Space Systems Technology - 1979, NASA CR-2118, 1980, pp. 287-301.
3. A. LeFever, "Space Platform Utilities Distribution Study," Final Report, Contract NAS 1-15322, NASA CR-159272, July 1980.

ACKNOWLEDGEMENTS

This study was sponsored by the NASA-LaRC under the technical direction and guidance of O. C. Childress, Jr. The baseline platform truss concept was developed and studied at the LaRC by several individuals including H. G. Bush, M. M. Mikulas, W. L. Heard, and M. F. Card. The results presented herein are also due to the creative efforts of several individuals at LMSC. The basic assembly machine concept was originally evolved by R. M. Bluck; this concept was further developed by G. G. Jacquemin, G. H. Grotbeck, and R. R. Johnson. Mr. Jacquemin was also responsible for the design of mechanisms for both the basic assembler and the implementation of utilities installation. Finally, Messrs. K. E. French, A. T. Saul and R. A. Michael provided valuable assistance and consultation during various phases of this study.