

## VIBRATION EXCITING MECHANISMS INDUCED

## BY FLOW IN TURBOMACHINE STAGES

William E. Thompson\*  
Turbo Research, Inc.  
Lionville, Pennsylvania 19353

## SUMMARY

The working fluid in a turbomachine stage can excite vibration of the rotor and must be included as an energy source for the system. The system then comprises both fluid and rotor structure, and in stating a stability criterion the damping of both must be considered:  $\delta_{\text{total}} = \delta_{\text{fluid}} + \delta_{\text{mech}} > 0$ .

Mechanical vibration perturbs the passage flow conditions which then excites or dampens the inducing vibration. Positive excitation (negative damping) results from the positive cross-coupled components of an unbalance force induced by the vibratory displacement as well as the orbital velocity of the rotor.

The equation of motion of flow in a turbomachine shows that unsteady flow is necessary for work transformation. The amplitude, frequency and phase angle of the unsteady flow phenomena must then be found to compare with the structural dynamics of the turbomachine.

Unsteady flow is identified by frequency and size of participating fluid ensemble. There occurs at blade passing frequency axial compressor and turbine blade flutter, and response to blade wakes and condensation shock wave oscillations. Near shaft rotational speed inlet distortion, gusts, rotating stall as well as self-excited shaft displacement and orbital velocity dependent forces are imposed upon the rotor. Surge occurs at system resonance frequency.

The quasi-steady computer analysis of the perturbed centrifugal impeller passage flow is reviewed. The fluid damping coefficient  $\delta_{\text{fluid}}$ , linear in the orbital velocity, is defined and based on 115 stage calculations, the average total damping coefficient per stage needed for stability is  $\delta_{\text{total}} > 1.85$ .

---

\* Currently with Borg-Warner Research Center, Des Plaines, Illinois.

## THE SYSTEM STABILITY CRITERION

There is a growing awareness of the fact that the flow of the working fluid in a turbomachine stage can interact with the structure of the turbomachine rotor in such a way that the distribution of the working fluid pressure over the passage surfaces is perturbed by the lateral vibration of the rotor due, for example, to residual mass unbalance. As a function of both flow conditions and passage geometry, the pressure perturbations, when summed over the surfaces, may result in unbalanced forces which introduce energy into the rotor and enhance the vibration. Such a vibration is deemed self-excited. On the other hand, the flow and geometry conditions may result in a net reduction of energy in the rotor and thus exert a vibration damping influence on the rotor.

Self-excited vibration phenomena are characterized by an available supply of energy and by a zero or negatively damped system. Here

System  $\equiv$  Mechanical structure *plus* Working fluid

Energy source  $\equiv$  Mechanical sources *plus* Working fluid

The rotor/bearing/pedestal subsystem, including the hydrodynamic bearing film, is generally positively damped. But the ability of bearings to dissipate energy is a function both of their design (style, dimensions, operating conditions, etc.) and their location along the rotor axis. Thus, positive damping of the subsystem cannot be assured a priori. Including the working fluid will either further increase or decrease the system damping. If overall damping capacity exceeds excitation, energy will flow out of the system and stability of the rotor will follow or be assured. But if excitation exceeds the capacity of the system to dissipate the energy, the net influx or accumulation of energy will rapidly produce rotor instability.

It is probably desirable to reduce the concept of energy flux with respect to each component of the system to a damping coefficient  $\delta$  appropriate to each component. The *system* stability criterion may then be expressed as

$$\delta_{\text{total}} = \delta_{\text{fluid}} + \delta_{\text{mech}} > 0 \quad (1)$$

Use of an energy criterion for evaluating turbomachinery system stability was suggested by Carta (1967, ref. 1) and further explained by him (ref. 2). A description of its application in a design procedure for axial flow compressor blading was given by Mikolajczak (1975, ref. 3) and a similar application in England was outlined by Halliwell (1977, ref. 4). In 1978, Thompson (ref. 5) introduced the stability increment for multistage centrifugal compressors which, upon comparison, proves to be identical to the criterion of eq. (1).

## NATURE OF EXCITATION

The unbalanced force which arises from the perturbed pressure and which is applied to the rotor and leads either to excitation or damping of

its vibration, can be resolved into direct and cross-coupled components. For rotor shaft *displacement* dependent forces, such as developed in shaft end or blade shroud labyrinth seals, the resolution is conveniently taken along and perpendicular, respectively, to the line between the bearing and journal centers. For rotor shaft orbital *velocity* dependent forces, such as developed by the working fluid in a turbomachine stage, the resolution is taken along and perpendicular, respectively, to a virtual radius to which the orbital velocity is perpendicular. The vector diagram of these forces is shown in fig. 1.

In each case, the component of the unbalanced force acting along the line of centers or along the virtual radius is denoted the direct component. If it is in the direction of  $n_2$  or  $n_2'$ , it has small stiffening effect on the system, somewhat raising the critical speeds and improving the stability. If the direct component acts in a negative  $n_2$  or  $n_2'$  direction, it has a slight softening effect, reducing critical speeds and stability margin.

In comparison, the components of the unbalanced force acting perpendicular to the line of centers or to the virtual radius are the cross-coupled components and directly affect the flux of energy to or from the rotor. If the cross-coupled component is in the  $n_1$  or  $n_1'$  direction, it adds energy, excites the rotor, and is a destabilizing influence. If it acts in a negative  $n_1$  or  $n_1'$  direction, it removes energy from the rotor and is a stabilizing influence. The conception of the effect on rotor system stability of the cross-coupled force components was first introduced by Kapitza (1939, ref. 6).

The unbalanced force, which affects both rotor vibration amplitude and system stability, has been attributed to perturbations of the pressure on the turbomachine stage passage surfaces. In particular in a reaction turbine stage, the effect in the rotor blade passage is comprised of the effect of the rotor orbital velocity and the influence of the seal leakage flow in modifying the throughflow velocity conditions. In addition there is the effect of the nonuniform circumferential static pressure due to nonuniform seal leakage around the periphery of the rotor blade shroud. Both passage and seal leakage effects are induced by rotor vibratory motion. The conception of the effect on rotordynamic stability of the seal leakage as it affects both blade performance and generates an unbalanced force was first introduced by Thomas (1958, ref. 7)

In more recent times, some valuable expositions have been made of the concepts given above. Ehrich (1972, ref. 8; 1973, ref. 9) identified an aeroelastic tip-clearance effect and presented the associated destabilizing force vector diagram. Alford (1965, ref. 10) in an oft-cited paper, identified two aerodynamic disturbing forces, the circumferential pressure variation in the seals and the variation of local efficiency in the rotor blade flow processes, where both were attributed to blade tip clearance. Based on very astute interpretation of the experimental test results of four gas turbine engines, Alford also concluded that rotor whirl resulting from fluid dynamic excitation was in the direction of rotor rotation, that whirl amplitude increased both with increased power output (i.e., in large

part with an increase in mass flow rate) and with decreased inlet temperature (i.e., with increased inlet density). These observations seem to be confirmed by experience accumulated up to the present time.

Pollman, Schwerdtfeger, and Termuehlen (1978, ref. 11) provided an extensive account of excitation mechanisms investigated by a European steam turbine manufacturer. Excitation of a fluid dynamic nature was comprised of the effects of seal leakage flow and load dependent influences, so-called "steam whirl." The latter were clearly defined as modification of local rotor blade passage efficiency caused by steam leakage flow and resulting in a local variation in torque developed in the blading. An unbalanced force in the direction of rotor rotation follows from the torque variation.

In Russia, work in this area is carried out at two research institutes, the Moscow Energetics Institute (MEI) and the Central Boiler-Turbine Institute (TsKTI) in support of steam turbine manufacturing. Kostyuk, et al. (1974, ref. 12) identified three nonconservative forces leading to self-excited vibrations. These were oil film bearing forces, seal leakage forces, and circumferentially varying blade forces due to seal leakage. Further Kostyuk, et al. (1975, ref. 13) reported work on two additional and important effects, that of the influence on the blading of passing through the wakes of upstream blades and that of unsteady separation on the blade surfaces due to condensation shock wave/boundary layer interaction which occurs at transonic and mildly supersonic velocities when the steam condition is supersaturated. These latter two effects clearly excite blade vibration, while the former induce rotor vibration. In a later report Kostyuk, et al. (1978, ref. 14) presented experimental results of labyrinth seal force measurements. Olimpiiev (1978, ref. 15) presented alternative work on varying blade forces, on shroud band seal leakage forces, and on labyrinth seal forces. He also mentioned that seal configurations could be devised to convert the influence from excitation to damping and that the circumferentially varying blade forces taken proportional to the rotor displacement producing them lead to an effective rotor stiffness coefficient.

#### NECESSITY OF UNSTEADY FLOW

Dean (1959, ref. 16) has explained the paradox encountered in applying Euler's equation (the equation of motion) to the problem of describing the change of state of the working fluid as work is transferred in a turbomachine. Consider a frictionless, reversible, adiabatic process in an idealized machine. This is simply an inviscid fluid subject to an isentropic process, which assumptions do not, in the present argument, invalidate the conclusions. The energy equation is simply and correctly given as

$$-w_s = h_{02} - h_{01} \quad (2)$$

For a compressor,  $h_{02} > h_{01}$  but for a turbine  $h_{02} < h_{01}$  and the sign of the result is entirely consistent with the conventions of thermodynamics.

However, Euler's equation (the differential form of the equations of motion) and Bernoulli's equation (integral form of the equations of motion)

are not applicable in describing the process in detail whereby the shaft work changes the state of the working fluid as it passes through blading of turbomachines. Instead, as Dean shows in detail for compressible flow, the equations of motion become

$$Dh_0/Dt = (1/\rho) \partial p/\partial t \quad (3)$$

and for incompressible flow

$$Dp_0/Dt = \partial p/\partial t \quad (4)$$

where the material derivative is the operator having unsteady and convective parts:

$$D/Dt = \partial/\partial t + (\bar{c} \cdot \nabla)$$

Thus, while the energy equation (2) demonstrates that stagnation enthalpy (or stagnation pressure) is changed as a consequence of shaft work, eq. (3) or eq. (4) shows, first, that the changes are with respect both to time and to changing location in the fluid field and, second, that both are a function of the time-varying or *unsteady* pressure fluctuations. Therefore, work transfer in a turbomachine *requires* an unsteady flow process. Spannhake (1930, ref. 17) perhaps was the first to point this out to turbomachine designers and analysts.

Three excellent reviews of unsteady flow phenomena can be identified, where in turn a large body of literature is cited. Mikolajczak (1976, ref. 18) pointed out that unsteady effects affect aerodynamic performance, aeroelastic and rotordynamic performance, and the generation of noise. Platzer (1978, ref. 19) provided an exhaustive account of unsteady phenomena in turbomachinery including the unsteady effects in machines exposed to uniform flow, the response to distorted inlet flow, surge and rotating stall conditions, as well as blade flutter. He categorized various prediction methods for these phenomena and described experimental studies. McCroskey (1977, ref. 20) included unsteady turbomachinery flow effects in a general review of unsteady fluid dynamics. Even so, he was able to make critical comments about flutter, inlet distortion, unsteady transonic flow, rotating stall, transitory diffuser stall, surge, vortex shedding from bluff bodies, and the definition of an unsteady Kutta-Joukowski condition. Finally, he included a projection of research needs and future developments.

Two time scales occur in the description of unsteady flow phenomena, the particle transport time:

$$\text{Characteristic length/Fluid velocity} = L/w \text{ [time]}$$

and the period of the pressure fluctuation:

$$1/\text{Fluctuation frequency} = 1/\nu \text{ [time]}$$

Their ratio becomes

$$(L\nu)/w \equiv k, \text{ the reduced frequency} \quad (5)$$

When the particle transport time is short with respect to the fluctuation period,  $k \rightarrow 0$  and the flow is said to be quasi-steady. Practically, for  $k \sim 0.1$ , the approximation of steady-flow analysis is often acceptable.

Lastly, unsteady phenomena may be transient or periodic. While a single transient event may have catastrophic consequences for a turbo-machine, such events occur over a relatively long period of time and are usually under the control of the process control system. On the other hand, periodic events characterize self-excited vibrations and are of concern here. Such periodic events fall into three categories as a function of both their frequency and a characteristic length of the participating fluid ensemble. For a characteristic length of the order of the blade thickness, the blade passing frequency is appropriate. Frequencies of the order of the shaft rotational speed are associated with phenomena of the size of the stage passages, while phenomena of the size of the bearing span occur at frequencies of the order of the overall duct system resonance. Vibration exciting mechanisms in each of the categories will be described in the next section.

#### SIZE/FREQUENCY CLASSIFICATION OF PHENOMENA

Three classifications according to size and frequency of the unsteady flow phenomena have been noted above. In each classification one finds a number of phenomena each one of which inherently possesses a mechanism for exciting vibration of the associated structural element. At the order of the blade passing frequency there occur axial compressor and axial turbine blade flutter together with blade vibration due to cutting upstream blade wakes as well as condensation shock wave oscillations. The last condition occurs in steam turbines where the expansion crosses the saturation line and the flow is at transonic speed in order to accommodate the large steam volume within a reasonable passage size. The frequency of the shock wave oscillations is below the blade passing frequency but much above the shaft rotational speed so it is included in this category.

At the order of the shaft rotational speed, inlet flow distortion, gusts in the flow and rotating stall in the rotor blading or the stationary interstage passages are external influences imposed on the rotor. In addition rotor vibration due to, say, residual mass unbalance is capable of inducing both displacement dependent and orbital velocity dependent excitation of the rotor. Finally at the order of the system resonance frequency, surge can occur.

All of these topics are listed in table 1 together with a group of references for each phenomena. The references have been chosen from among a very large number because each in turn identifies and to a great extent evaluates the contributions of a subsequent set of references. In connection with table 1, the writer is indebted to William G. Steltz, Power Generation Divisions, Westinghouse Electric Corp. for the references on condensation shock wave phenomena.

Consistent with the present workshop on rotordynamic instability, phenomena at the order of the shaft synchronous frequency will be emphasized and blade vibration and system surge will not be considered further. Further we understand that from the unsteady flow phenomena there needs to be derived the amplitude, frequency and phase angle of a forcing function which, for analytical purposes, can then be imposed on the rotor system.

But it cannot be expected that all topics in table 1 are so well developed fluid dynamically that clear, realistic and practical forcing functions will be available for our use.

#### ORBITAL VELOCITY-DEPENDENT EXCITATION

The orbital velocity induces the unbalanced fluid dynamic force which is imposed on the rotor of a turbomachine. In both figures 2 and 3, the rotor centerline describes a trajectory or orbit during lateral vibratory motion. The instantaneous tangential velocity of the shaft center along the trajectory is the rotor orbital velocity.

The angular velocity of the rotor results in a tangential velocity at each location on the rotor proportional to its radius from the shaft center. Then for the leading edges of the blades as shown in figures 2 and 3, when the velocity due to rotation and the orbital velocity are in the same sense, they add and when in opposite sense, they subtract. The effect is as if the rotor rotation took place instantaneously about a virtual center displaced from the geometric shaft center as shown in the figures. Those flow passages at the greater radii from the virtual center handle a somewhat greater mass flow and exchange a somewhat greater angular momentum with the fluid than do those at the smaller radii. Blade surface pressure distributions in the flow passages will now vary with the virtual radii, not the geometric radii, and will be nonuniform from passage to passage. Summation of the pressure distributions in all passages at an axial location on the rotor will thus result in an unbalanced force on the rotor.

In the case of the radial compressor in fig. 2, the rotor orbital motion causes the blade leading edges to move in and out radially and, as the orbital velocity first adds then subtracts from the rotational velocity, to accelerate then decelerate tangentially with respect to a steady fluid flow into the passages. Thus, relative to the rotor, the blade appears to be moving through a gust having both lateral and longitudinal components of perturbed velocity and pressure. Such perturbations move in a series of waves over the length of the blade with a frequency equal to the rotor lateral vibratory frequency. In practice this frequency is the sub-synchronous frequency of the rotor/bearing/pedestal system. Isay (1958, ref. 69) appears to offer the only known analysis of such unsteady flow.

In much the same way, orbital motion induces velocity perturbations, modified incidence angles, etc. in an axial compressor rotor as shown in fig. 3. In addition the same orbital motion produces varying blade tip clearance or blade shroud band clearance about the periphery at a given rotor axial location yielding varying leakage. The local variation of the leakage modifies the local pressure rise in an axial compressor stage and modifies the local pressure drop in a turbine stage. Thus the velocity perturbation from the orbital motion and the pressure perturbation from the rotor orbital displacement combine to perturb the passage flow non-uniformly from passage to passage resulting in an unbalanced force on the rotor. In the case of the axial flow steam turbine, the combined influence of leakage and orbital motion is called steam whirl.

## EXAMPLE: THE CENTRIFUGAL COMPRESSOR STAGE

At the outset of this work, ref. 69 was unknown to the writer and circumstances did not permit developing the unsteady flow analysis. Invoking quasi-steady conditions, a "snap shot" was made encompassing the flow in every impeller channel where each is perturbed differently by the shaft orbit velocity. When the blade or channel length is a sufficiently small portion of the disturbance wave length, the flow conditions imposed for an instant on the blade can be considered approximately steady. Expressed in terms of the reduced frequency introduced above,  $k < 0.2$  will usually be adequate for the approximation to hold. The fluctuation frequency is given by the shaft subsynchronous frequency.

A computer program was organized to analyze each and every impeller passage under perturbed, quasi-steady conditions; to resolve the summation of the pressure distribution into components of  $F_1$  and  $F_2$  contributed by each passage; and finally to sum the contributions to  $F_1$  and  $F_2$ . Practical considerations showed that typical orbital velocities are 0.05 to 0.20 m/s (2 to 8 in./s) in comparison to the passage relative fluid velocity of 46 to 185 m/s (150 to 600 ft/sec). The unbalanced force resulting from such a small perturbation of the velocity proved, upon calculation, to be linear in the orbital velocity. Thus  $F_1 = b_1 u_t$ ,  $F_2 = b_2 u_t$ , and the contribution of the working fluid to the system stability criterion becomes

$$\delta_{\text{fluid}} = -b_1 = -F_1/u_t \quad (6)$$

The negative sign is needed because a positive excitation corresponds to a negative damping. For an extended explanation of these ideas as well as numerical results for a compressor comprising fourteen stages in two casings, the reader is referred to ref. 5.

## CONCLUDING REMARKS

The system stability criterion given in ref. 3 is shown in eq. 1. For the relatively simple blade structural system considered in ref. 3, use of the ideal, zero boundary between stability and instability is evidently justified. Such is not the case in the much more complex rotor/bearing/pedestal/working fluid system. As a result of analyzing 115 individual centrifugal compressor stages which were contained in 20 multistage bodies, the average coefficient per stage needed to assure stability may be suggested as  $\delta_{\text{total}} = 1.85$ . Referring again to eq. 1, only  $\delta_{\text{fluid}}$  is the subject of this paper while  $\delta_{\text{mech}}$  must be determined by other rotodynamic analysis.

Each length/frequency classification of excitation phenomena, once analyzed, will admit suggestions for designing in additional damping of a fluid dynamic nature. Regarding blade flutter, ref. 3 suggests that an entire blade fluid and structural design system has been organized and can yield optimized results. Regarding distorted inlet flow to axial compressors, criteria are emerging (refs. 70, 71) which will lead to configurations which are insensitive to such external influences. Work in this direction for radial turbomachines lags that of axial machines. Finally overall system design ignores completely the opportunity to add damping to minimize



the effects of surge.

Regrettably the limitation on scope of this paper due to both preparation time and space has precluded including examples of other phenomena in table 1, an evaluation of the numerical fluid mechanical methods which are used to obtain quantitative predictions of the damping coefficients and evaluation of various experimental techniques for observing unsteady flow and deriving the force and damping coefficients from such observations.

#### SYMBOLS

$a_1, a_2$	displacement dependent fluid force coefficient, N/m (lbf/in.)
$\bar{a}_1, \bar{a}_2$	stator-fixed coordinates system, m (ft)
$b_1, b_2$	orbital velocity dependent fluid force coefficient, N-s/m (lbf-s/in.)
$c$	fluid absolute velocity, m/s (ft/s)
$F_1 = F_{b1}$	cross-coupled force component due to fluid dynamic excitation, N (lbf)
$F_2 = F_{b2}$	direct force component due to fluid dynamic excitation, N(lbf)
$h$	static enthalpy, m-N/kg(ft-lbf/slug)
$h_0$	stagnation enthalpy, m-N/kg (ft-lbf/slug)
$k$	reduced frequency
$L$	characteristic length, m(ft)
$\bar{n}_1, \bar{n}_2, \bar{n}_3$	rotor-fixed coordinate system, m(ft)
$p$	static pressure, kPa(psia)
$p_0$	stagnation pressure, kPa(psia)
$r$	radial coordinate, m(ft)
$u$	blade peripheral velocity, m/s (ft/s)
$\bar{u}_t$	rotor orbital velocity, m/s (in./s)
$w$	fluid relative velocity, m/s (ft/s)

$w_s$	shaft work, m-N/kg (ft-lbf/slug)
$\delta$	damping coefficient, N-s/m (lbf-s/in.)
$\bar{\delta}$	rotor displacement, m(in.)
$\nu$	fluctuation frequency (rotor subsynchronous frequency), 1/s
$\rho$	density, kg/m <sup>3</sup> (slugs/ft <sup>3</sup> )
$\omega$	angular velocity, rad/s

#### REFERENCES

1. F. O. Carta, "Coupled Blade-Disk-Shroud Flutter Instabilities in Turbojet Engine Rotors", *Journal of Engineering for Power, ASME Transactions*, Vol. 89, No. 3, 419-426, July 1967.
2. F. O. Carta, "Turbomachinery Flutter: Introductory Concepts", *Industrial Compressors*, Vol. 1, Lecture Series 91, von Karman Institute, Belgium, May 1976.
3. A. A. Mikolajczak, R. A. Arnoldi, L. E. Snyder, H. Stargardter, "Advances in Fan and Compressor Blade Flutter Analysis and Predictions", *Journal of Aircraft*, Vol. 12, No. 4, 325-332, April 1975.
4. D. G. Halliwell, "The Characteristics, Prediction and Test Analysis of Supersonic Flutter in Turbofan Engines", *Vibration in Rotating Machinery*, Institution of Mechanical Engineers Conference Publication 1976=9, 181-185, 1977.
5. W. E. Thompson, "Fluid Dynamic Excitation of Centrifugal Compressor Rotor Vibrations", *Journal of Fluids Engineering, ASME Transactions*, Vol. 100, No. 1, 73-78, March 1978.
6. P. L. Kapitza, "Stability and Passage through the Critical Speeds of High Speed Rotors in the Presence of Friction" (in Russian), *Zhurnal Tekhnicheskoi Fiziki*, Vol. 9, No. 2, 124-127, 1939.
7. H. J. Thomas, "Unstable Oscillations of Turbine Rotors Due to Steam Leakage in the Clearances of the Sealing Glands and Buckets" (in German), *Bulletin Scientifique, A.I.M.*, Vol. 71, 1039-1063, 1958.
8. F. F. Ehrich, "Identification and Avoidance of Instabilities and Self-Excited Vibrations in Rotating Machinery", Paper No. 72-DE-21, ASME, May 1972.
9. F. F. Ehrich, "An Aeroelastic Whirl Phenomena in Turbomachinery Rotors", Paper No. 73-DET-97, ASME, September 1973.

10. J. S. Alford, "Protecting Turbomachinery from Self-Excited Rotor Whirl", *Journal of Engineering for Power, ASME Transactions*, Vol. 87A, No. 4, 333-344, October 1965.
11. E. Pollman, H. Schwerdtfeger, H. Termuehlen, "Flow Excited Vibrations in High Pressure Turbines (Steam Whirl)", *Journal of Engineering for Power, ASME Transactions*, Vol. 100, No. 2, 219-228, April 1978.
12. A. G. Kostyuk, V. F. Shatokhin, N. M. Ivanov, "Calculation of the Threshold Capacity of Large Turbine Generators" (English Translation), *Thermal Engineering*, Vol. 21, No. 3, 19-25, 1974.
13. A. G. Kostyuk, M. E. Deich, G. S. Samoilovich, G. M. Troyanovskii, G. A. Filippov, A. E. Bulkin, "Some Problems of Increasing the Efficiency and Reliability of High Capacity Turbines" (English Translation), *Thermal Engineering*, Vol. 22, No. 12, 5-12, 1975.
14. A. G. Kostyuk, A. V. Kiryukhin, "Autoscillations and Stability of Turbine Rotors in Sleeve Bearings with Allowance for Nonconservative Aerodynamic Forces" (In Russian), *Teploenergetika*, Vol. 25, No. 9, 14-19, September 1978; (German Translation) *Archiv für Energiewirtschaft*, Vol. 32, No. 12, 996-1005, 1978; (English Abstract) *Thermal Engineering*, Vol. 25, No. 9, p 71, 1978.
15. V. N. Olimpiev, "Problems of Preventing Low-frequency Vibrations of Shafts of High Capacity Steam Turbine Units" (English Translation), *Thermal Engineering*, Vol. 25, No. 9, 8-14, September 1978.
16. R. C. Dean, "On the Necessity of Unsteady Flow in Fluid Machines", *Journal of Basic Engineering, ASME Transactions*, Vol. 81D, No. 1, 24-28, March 1959.
17. W. Spannhake, "A Fluid Mechanics Problem in Turbomachine Research and an Essay on Its Solution" (In German), *Mitteilungen der Instituts für Strömungsmaschinen, T. H. Karlsruhe*, Vol. 1, 1930.
18. A. A. Mikolajczak, "The Practical Importance of Unsteady Flow", *Unsteady Phenomena in Turbomachinery*, Conference Proceedings 177, AGARD, Paris, April 1976.
19. M. F. Platzer, "Unsteady Flows in Turbomachines - Review of Current Developments", *Unsteady Aerodynamics*, Conference Proceedings 227, AGARD, Paris, February 1978.
20. W. J. McCorskey, "Some Current Research in Unsteady Fluid Dynamics", *Journal of Fluids Engineering, ASME Transactions*, Vol. 99I, No. 1, 8-39, March 1977.
21. F. Sisto, "A Review of the Fluid Mechanics of Aeroelasticity in Turbomachines", *Journal of Fluids Engineering, ASME Transactions*, Vol. 99I, No. 1, 40-44, March 1977.

22. R. Pigott, "Forced and Self-excited Vibrations of Transonic Turbine Cascades", Ph. D. Thesis, University of Pennsylvania, 1975.
23. J. H. Horlock, "Fluctuating Lift Forces on Aerofoils Moving Through Transverse and Chordwise Gusts", *Journal of Basic Engineering, ASME Transactions*, Vol. 90D, No. 4, 495-500, December 1968.
24. H. Yeh, H. Naumann, "Unsteady Induced Velocities in a Cascade", 2nd JSME Symposium *Fluid Machinery and Fluidics*, 201-207, September, 1972.
25. R. Mani, "Compressibility Effect in the Sears-Kemp Problem", *Fluid Mechanics Acoustics, and Design of Turbomachinery*, SP-304, Pt II, 513-533, NASA, 1974.
26. B. Lakshminarayana, "The Nature of Flow Distortion Caused by Rotor Blade Wakes", *Unsteady Phenomena in Turbomachines*, Conference Proceeding 177, AGARD, Paris, April 1976.
27. S. Fleeter, R. L. Jay, W. A. Bennett, "Wake Induced Time-variant Aerodynamics Including Rotor-Stator Axial Spacing Effects", *Nonsteady Fluid Dynamics*, ASME Special Publication, 147-163, December 1978.
28. H. G. Stever, "Condensation Phenomena in High Speed Flow", Section F. *Fundamentals of Gas Dynamics*, Vol. III, Jet Propulsion Series, Princeton University Press, 1958.
29. G. A. Saltanov, "Nonstationary Flows of Superheated and Condensing Steam" (in Russian), *Prave Instytutu Maszyn Przeplywowych*, Vol. 70-72, 433-451, 1976.
30. G.E.A. Meier, "Shock-induced Flow Oscillations in a Laval Nozzle", IUTAM Symposium Transonicum II, Göttingen, September 1975.
31. M. E. Deich, A. G. Kostyuk, G. A. Saltanov, G. A. Filippov, A. N. Kukushkin, G. P. Simanovskii, "Analysis of Transient Processes in the Flow Sections of Wet Steam Turbines" (English Translation), *Thermal Engineering*, Vol. 24, No. 2, 28-34, February 1977.
32. B. N. Troyanoskii, E. V. Majorskii, V. V. Lakin, B. A. Garagulya, "Supersonic Cascades in the Last Stages of High-Capacity Steam Turbines" (English Translation). *Thermal Engineering*, Vol. 24, No. 10, 7-12, 1977.
33. Y. V. Rzhaznikov, E. A. Boitsova, O. A. Kuzinenko, "Determination on a Static Model of the Stiffness Factor of the Transverse Circulation Force in Steam Turbines" (English Translation), *Thermal Engineering*, Vol. 24, No. 2, 48-53, February 1977.
34. B. Lakshminarayana, "Methods of Predicting the Tip Clearance Effects in Axial Flow Turbomachinery", *Journal Basic Engineering, ASME Transactions*, Vol. 92D, No. 3, 467-482, September 1970.

35. F. Sisto, "Aeromechanical Response", *Distortion Induced Engine Instability*, Lecture Series 72, AGARD, Paris, November 1974.
36. H. Mokolke, "Prediction Techniques", *Distortion Induced Engine Instability*, Lecture Series 72, AGARD, Paris, November 1974.
37. B. Lakshminarayana, "Effects of Inlet Temperature Gradients on Turbomachinery Performance", *Journal Engineering for Power*, ASME Trans. Vol. 97A, No. 1, 64-74, January 1975.
38. E. P. Bruce, R. E. Henderson, "Axial Flow Rotor Unsteady Response to Circumferential Inflow Distortions", *Unsteady Phenomena in Turbomachinery*, Conference Proceedings 177, AGARD, Paris, April 1976.
39. R. S. Mazzawy, "Multiple Segment Parallel Compressor Model for Circumferential Flow Distortion", *Journal Engineering for Power*, ASME Trans. Vol. 99A, No. 2, 288-296, April 1977.
40. J. Fabri, "Growth of a Perturbation in an Axial Flow Compressor", *Journal Engineering for Power*, ASME Trans. Vol. 101, No. 1, 87-94, January 1979.
41. R. E. Henderson, "Unsteady Response of a Blade Row from Measurements of the Time-mean Total Pressure", Paper No. 73GT-94, ASME, April 1973.
42. B. Satyanarayana, "Some Aspects of Unsteady Flow Past Airfoils and Cascades", *Unsteady Phenomena in Turbomachinery*, Conference Proceeding 177, AGARD, Paris, April 1976.
43. R. E. Henderson, J. H. Horlock, "An Approximate Analysis of the Unsteady Lift on Airfoils in Cascade", *Journal Engineering for Power*, ASME Trans., Vol. 94A, No. 4, 233-240, October 1972.
44. B. Satyanarayana, R. E. Henderson, J. P. Gostelow, "Comparison Between Experimental and Theoretical Fluctuating Lift on Cascades at Low Frequency Parameters", Paper No. 74GT-78, ASME, March 1974.
45. J. H. Horlock, E. M. Greitzer, R. E. Henderson, "The Response of Turbomachine Blades to Low Frequency Inlet Distortions", *Journal Engineering for Power*, ASME Trans., Vol. 99A, No. 2, 195-203, April 1977.
46. H. Takata, S. Nagano, "Nonlinear Analysis of Rotating Stall", *Journal Engineering for Power*, ASME Trans., Vol. 94A, No. 4, 279-293, October 1972.
47. E. M. Greitzer, "Surge and Rotating Stall in Axial Flow Compressors: I, II", *Journal Engineering for Power*, ASME Trans., Vol. 98A, No. 2, 19-217, March 1975.

48. I. J. Day, N. A. Cumpsty, "Measurement Interpretation of Flow Within Rotating Stall Cells in Axial Compressors", *Journal Mechanical Engineering Science*, Vol. 20, No. 2, 101-114, April 1978.
49. P. Hergt, P. Krieger, "Radial Forces in Centrifugal Pumps with Guide Vanes", *Advance-Class Boiler Feed Pumps, Proceedings Inst. of Mechanical Engineers*, Vol. 184, No. 3N, 101-107, 1969-1970.
50. U. Domm, P. Hergt, "Radial Forces on Impellers of Volute Casing Pumps", *Flow Research on Blading*, Editor L. S. Dzung, 305-321, Elsevier Pub. Co. 1970.
51. H. F. Black, "Calculation of Forced Whirling and Stability of Centrifugal Pump Rotor Systems", *Journal Engineering for Industry, ASME Trans.*, Vol. 96I, No. 3, 1076-1081, August 1974.
52. H. F. Black, "Lateral Stability and Vibrations of High Speed Centrifugal Pump Rotors", *Dynamics of Rotors*, 56-74, Springer Verlag, New York, 1975.
53. S. Mizuki, Y. Kawashima, I. Ariga, "Investigation Concerning Rotating Stall and Surge Phenomena within Centrifugal Compressor channels", Paper No. 78GT-9, ASME, April 1978.
54. Y. Senoo, Y. Kinoshita, "Limits of Rotating Stall and Stall in Vaneless Diffuser of Centrifugal Compressors", Paper No. 78GT-19, ASME, April 1978.
55. C. Rodgers, "A Diffusion Factor Correlation for Centrifugal Impeller Stalling", *Journal Engineering for Power, ASME Trans.* Vol. 100, No. 4, 592-603, October 1978.
56. A. N. Abdelhamid, W. H. Colwill, J. F. Barrows, "Experimental Investigation of Unsteady Phenomena in Vaneless Radial Diffusers", *Journal Engineering for Power, ASME Trans.*, Vol. 101, No.1, 52-60, January 1979.
57. H. W. Emmons, "Introduction", *Compressor Stall, Surge and System Response*, Special Publication, ASME, 1960.
58. E. J. Taylor, "The Centrifugal Compressor", Section J, *Aerodynamics of Turbines and Compressors*, Vol. X, Jet Propulsion Series, Princeton University Press, 1964.
59. J. L. Dussourd, "An Investigation of Pulsations in the Boiler Feed System of a Central Power Station", *Journal Basic Engineering, ASME Trans.*, Vol. 90D, No. 4, 607-619, December 1968.
60. P. H. Rothe, P. W. Runstadler, "First-order Pump Surge Behavior", *Journal Fluids Engineering, ASME Trans.* Vol. 100, No. 4, 459-466, December 1978.

61. P. H. Rothe, P. W. Runstadler, F. X. Dolan, "Pump Surge Due to Two-phase Flow", *Polyphase Flow in Turbomachinery*, 121-137, Special Publication, ASME, December 1978.
62. H. M. Schultz, R. K. Miyasaki, T. B. Liem, R. A. Stanley, "Analog Simulation of Compressor Systems, A Straightforward Approach", CPD 74106, Instrument Society of America, 1974.
63. K. Toyama, P. W. Runstadler, R. C. Dean, "Experimental Study of Surge in Centrifugal Compressors", *Journal Fluids Engineering, ASME Trans.*, Vol. 99I, No. 1, 115-131, March 1977.
64. D. H. McQueen, "On the Dynamics of Compressor Surge", *Journal Mechanical Engineering Science*, Vol. 18, No. 5, 234-238, 1976.
65. J. L. Dussourd, G. W. Pfannebecker, S. K. Singhania, "Experimental Investigation of the Control of Surge in Radial Compressors Using Close Coupled Resistances", *Journal Fluids Engineering, ASME Trans.*, Vol. 99I, No. 1, 64-75, March 1977,
66. G. Gyarmathy, "Nonlinear Analysis of Surge Cycles", *Journal Fluids Engineering, ASME Trans.*, Vol. 99I, No. 1, 258-259, March 1977.
67. A. Kolnsberg, "Reasons for Centrifugal Compressor Surging and Surge Control", *Journal Engineering for Power, ASME Trans.*, Vol. 101, No. 1, 79-86, January 1979.
68. R. S. Mazzawy, "Surge-induced Structural Loads in Gas Turbines", Paper No. 79GT-91, March 1979.
69. W. H. Isay, "The Flow Through a Vibrating and Rotating Radial Cascade" (In German), *Zeitschrift fur Flugwissenschaft*, Vol. 6, No. 11, 319-328, 1958.
70. R. E. Henderson, "The Unsteady Design of Axial-flow Turbomachines", *Proceedings Joint Symposium on Design and Operation of Fluid Machinery*, Vol. II, 91-108, Colorado State University, June 1978.
71. E. P. Bruce, "Axial Flow Rotor Unsteady Performance", TM79-149, Applied Research Laboratory, Penn State University, August 14, 1979.

Table 1 Size-frequency Classification of Vibration Excitation Mechanisms

Topics	References
Blade thickness/blade passing phenomena	
Axial compressor blade flutter	19, 3, 2, 21
Axial turbine blade flutter	22
Wake flow excitation	23, 24, 25, 26, 27
Condensation shock wave excitation	28, 29, 30, 31, 32
Passage dimension/shaft synchronous phenomena	
Axial configuration:	
Rotor displacement dependent	7, 10, 33, 34
Orbital velocity dependent	
Inlet distortion	35, 36, 37, 38, 39, 40
Gusts	41, 42, 43, 44, 45
Rotating stall	46, 47, 48
Radial configuration:	
Rotor displacement dependent	49, 50, 51, 52
*Orbital velocity dependent	5
Rotating stall	53, 54, 55, 56
Bearing span/systems resonance	
Surge:      General	57, 58
Pump	59, 60, 61
Compressor	62, 63, 64, 65, 66, 67, 68

\* An example will be presented in the text.



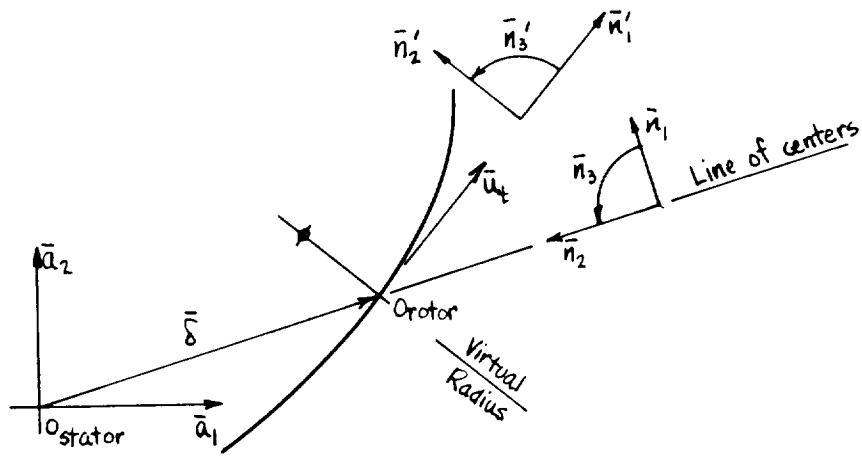

$\bar{n}_1, \bar{n}'_1$  cross-coupled component unit vectors

$\bar{n}_2, \bar{n}'_2$  direct component unit vectors

$$\bar{F} = \bar{F}_a + \bar{F}_b$$

Where  $\bar{F}_a$  is the displacement dependent force,

$$\bar{F}_a = F_{a1} \bar{n}_1 - F_{a2} \bar{n}_2$$

and  $\bar{F}_b$  is the velocity dependent force,

$$\bar{F}_b = F_{b1} \bar{n}'_1 - F_{b2} \bar{n}'_2$$

Further the rotor displacement vector  $\bar{\delta}$

$$\bar{\delta} = \delta(-\bar{n}_2)$$

and the orbital velocity vector  $\bar{u}_t$  is

$$\bar{u}_t = u_t \bar{n}'_1$$

Since  $\bar{F}_a$  and  $\bar{F}_b$  are linear in  $\bar{\delta}$  and  $\bar{u}_t$  respectively

$$F_{a1} = a_1 \delta, \quad F_{a2} = a_2 \delta$$

$$F_{b1} = b_1 u_t, \quad F_{b2} = b_2 u_t$$

(Note:  $F_1 = F_{b1}$ ,  $F_2 = F_{b2}$  in text)

Figure 1 Description of Fluid Dynamic Forces

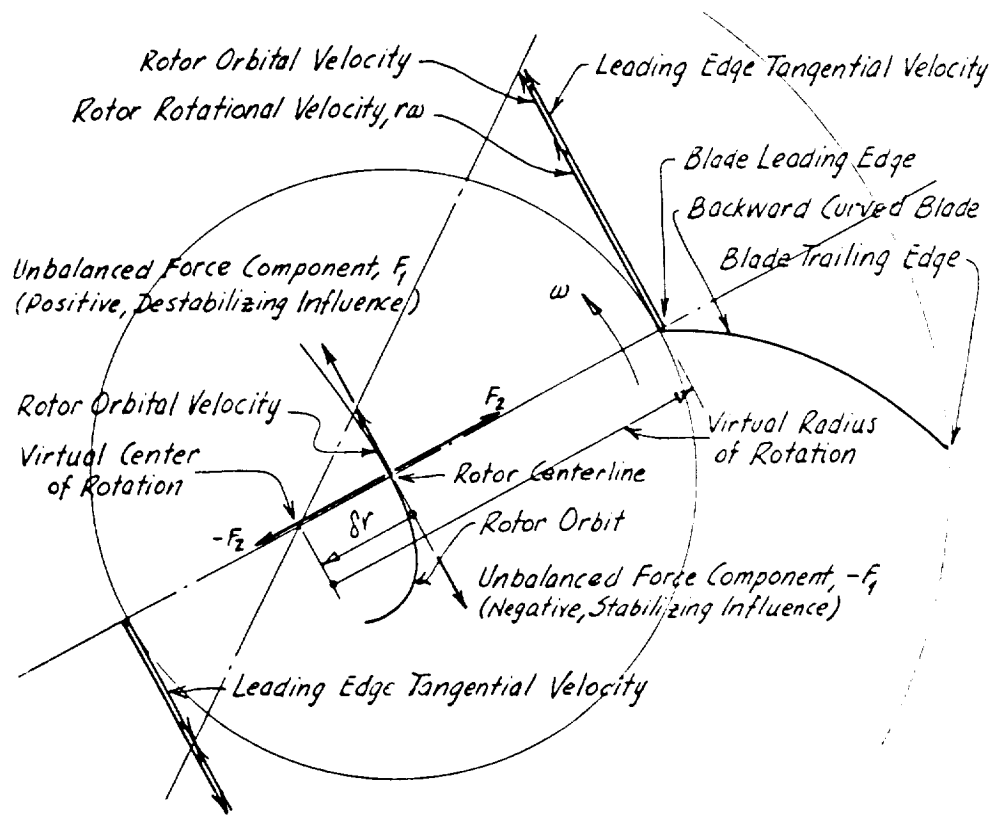

Figure 2 - Fluid Dynamic Excitation Force of a Radial Compressor Impeller

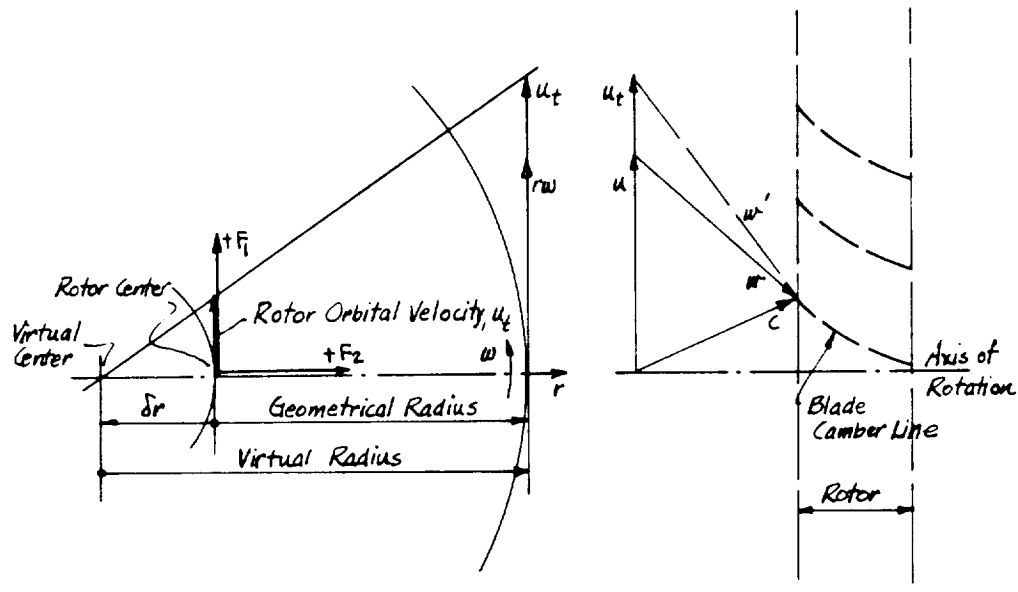

Figure 3 Fluid Dynamic Excitation Force of an Axial Compressor Rotor