

D25
N80 23520

A POLARIMETER FOR THE HIGH RESOLUTION
ULTRAVIOLET SPECTROMETER/POLARIMETER

John A. Calvert
George C. Marshall Space Flight Center

INTRODUCTION

The High Resolution Ultraviolet Spectrometer/Polarimeter (HRUVSP) is an experiment to be launched aboard the Solar Max Mission sometime in early 1980. The HRUVSP will allow the study of active solar regions through ultraviolet polarimetry and spectroscopy. The polarization capability, along with other modifications, was added to an existing engineering model of the OSO-8 High Resolution Spectrometer.

The High Resolution Ultraviolet Spectrometer/Polarimeter is depicted in Figure 1. The polarimeter (λ wave plate) is shown enclosed by a heavy line.

This paper will deal specifically with the mechanical design, testing, and operation of the polarimeter for the HRUVSP.

DESIGN REQUIREMENTS

The design requirements of the polarimeter were established by the scientific optical objectives of the experiment. The polarization of the light is accomplished by a rotating magnesium fluoride quarter wave plate. The quarter wave plates are rotated in $22\frac{1}{2}$ -degree steps about an axis coincidental with the light beam. As the light beam passes through the wave plate, the transformation that occurs can be expressed by mathematical equations. By having the wave plates calibrated, the data obtained from solar flares can be analyzed and meaningful information provided to the investigators. The polarimeter has two wave plates with different optical characteristics to provide both redundancy and versatility. A four-mirror polarizer was added behind one wave plate to provide additional polarization.

MECHANICAL DESIGN

The polarimeter mechanical design was required to provide three positions for the wave plates: either one of the wave plates in the light path or both wave plates out of the light path. When the wave plate is in the light path, rotation in $22\frac{1}{2}$ -degree steps is necessary. To provide the quality of data

required, the centerline of rotation of the wave plates was not to be over 1.8 mm from centerline of the light path; and the deviation from the desired $22\frac{1}{2}$ -degree rotation of the wave plates was to be less than $\frac{1}{2}$ degree.

In addition to the above optical criteria, the design was required to:

1. Provide mechanical and electrical redundancy;
2. Have low electrical power usage;
3. Maintain cleanliness for wave plates and other optics in the experiment;
4. Fit into an existing cavity (12.7 cm wide x 11.4 cm long x 8.9 cm high);
5. Operate intermittently for one year in space; and
6. Provide a data feedback system to indicate wave plate position and rotation.

DESCRIPTION

The polarimeter is shown in artist's conception in Figures 2 and 3.

WAVE PLATE ROTATION SYSTEM

The quarter wave plates are two layers of magnesium fluoride optically bonded together to a total thickness of .600 mm and an open diameter of 7.0 mm. The plates are fragile and cannot be easily handled alone. A structural holding ring was designed to provide a safe method of handling and a means of securing the wave plates into the barrel assembly. The complete wave plate-holding ring assembly is shown in Figure 4. The holding ring was made of a non-outgassing plastic material .051 mm thicker than the recess in the barrel. This additional thickness insured that the quarter wave plates were securely held, and vibration would not cause the plates to move. After initial installation and rotational alignment of the wave plates, the plastic holding rings and keeper rings were drilled for installation of an alignment pin so the wave plate assemblies could be removed and reinstalled precisely.

The limited volume available to house the polarimeter dictated the use of small stepper motors (Figure 5). The available running torque of 44.6 cm-gm (.62 oz-in) and precision optical alignment requirements made a precision gear mesh, low friction system mandatory. Four motors, as depicted by Figure 5, were used in the polarimeter.

Each of the two wave plate rotation systems consisted of a stepper motor driving through a 96 pitch, 31 tooth spur gear pinned to its shaft and the barrel assembly (Figure 4) with a 96 pitch, 124 tooth spur gear. Both barrel assemblies and their respective drive motors were held by a single machined aluminum housing. This housing gave the best opportunity for maintaining the tolerances required for proper gear tooth operation and also for maintaining the alignment required for the optics. This design approach required close tolerancing and precision machining operations; but because of the limited volume available for the polarimeter, there was no space available for adjustments if separate assemblies had been used.

The wave plates had to be rotated (one direction only) in $22\frac{1}{2}$ -degree steps at 7.8 steps/second with data being taken while the wave plates were at rest. It was required that the plates complete one rotation every two seconds. The step pulse width of the wave plate rotation motor was 23 milliseconds, and oscillation of the plate was to be less than $\frac{1}{2}$ degree after 20 milliseconds. The usual procedure of sending a pulse to the motors and allowing the friction to damp out the oscillations of the wave plate required too much of the time allocated for each step. A special control circuit was designed so that after the motor steps the motor windings were shorted to make use of viscous damping caused by the generated EMF. This gave two improvements to the design: it shortened the step-oscillation time and also gave a more repeatable positioning of the wave plates. During design of the barrel assembly, the inertia was kept as low as possible to help in the damping of the oscillations and to decrease the time to step the wave plates. During assembly of the barrel assembly into the machined housing, care was taken to have the minimum preload possible on rotational bearings to give stability but have minimum friction possible.

WAVE PLATE POSITIONING SYSTEM

As indicated previously, the wave plate positioning system has three positions: wave plate "A" in the light path, both wave plates out of the light path, and wave plate "B" in the light path. The insertion-retraction system is capable of placing either wave plate into or out of the light beam.

The system has two stepper motors (Figure 5) identical to the wave plate rotation motors, both driving through a 31 tooth spur gear to a 124 tooth spur gear. One stepper motor is fixed to the support plate, the other is movable about the worm gear (Figures 2 and 3). For the movable motor to operate, the worm gear and supporting shaft are held fixed by the magnetic detent of the stepper motor and the non-backdrive characteristic of a single thread worm. The movable motor is pulsed 140 steps at a rate of 15.625 steps/second and, through a 280:1 total gear reduction (4:1 spur gear, 70:1 worm gear), the movable motor and worm move $\pm 45^\circ$ around the worm gear. Depending upon motor rotation direction, either wave plate will be placed into the light path. The outer assembly rotates about the supporting shaft on four bearings. For the fixed motor to operate, the outer rotational assembly was fixed to the worm gear; and the fixed motor rotated the worm gear, supporting

shaft, and rotational assembly as a unit. The supporting shaft rotated in bearings in the support posts at either end of the shaft.

This arrangement had the advantage of mechanical redundancy (either motor could place either wave plate into the light path without having to backdrive the other; and completely separate sets of bearings were provided for each mode of operation) without having to have a differential in the drive system.

The method of operation of the insertion-retraction motors was to select either motor for operation, designate direction of rotation, and the electronics would send 140 pulses at a rate of 15.6 steps/second to the designated motor. This would place the selected wave plate into the light path. A feedback system, to be discussed later, would then send a signal to indicate the wave plate was in the proper position. The signal also served as a redundant cutoff in case of electronic malfunction, and more than 140 step commands were given.

The insertion-retraction motors (IRM) did not have the non-oscillating requirements of the wave plate rotation motors, but more torque was required. Also the IRM was to be operated only a short period of time, so electrical power consumption was not as important a consideration. For these reasons a pulse width of .030 second was used. This gave more assurance that a step would not be missed, and the wave plates would be in position for data taking.

Both the wave plate rotational system and the insertion-retraction system had a method of position feedback (reference Figures 2 and 3). Each wave plate had rotational sensors that indicated once per revolution. The sensors were photodiodes and phototransistors. A hole was provided in the spur gear on the barrel assembly for the phototransistor to sense the light emitted by the photodiode. The photodiode is pulsed rather than powered constantly to provide additional electrical power savings. The insertion-retraction position sensors were required to provide a one motor step resolution so the wave plates could be positioned to within 1.8 mm (one step accuracy) about the optical light path. The position plate is fixed to the wave plate holder machining. It has one slot .2 mm wide in the center to correspond to the out of light path position. On each side of the position plate a sharp edge is used for reference. An edge was used as it allowed fitting at assembly to achieve the minimum possible deviation from the light path. The low light level of the photodiode and the small hole (.2 mm diameter) in the mask required the phototransistor be placed as close as possible to the photodiode.

LUBRICATION

The cleanliness requirements of the optics made the lubrication an important design consideration. Any coating of the optics due to outgassing would reduce the ultraviolet light throughput of the wave plates. Both gears and bearings were lightly loaded, but the bearings and spur gears of the wave plate rotational system had a possible 6.3×10^7 cycle lifetime requirement.

Tests were conducted to compare low outgassing grease and also dry lubricant. It was found the grease contaminated the optics and could not be used. The dry lubricant was applied to all bearings and all spur gears. It was still necessary to shield the optics from line of sight relationship to the open spur gears to prevent any dry lubricant which might separate during operation from being deposited onto the optics.

The worm-worm gear interface was a special consideration. Dry lubrication was not considered satisfactory because of the sliding action of the gears. The worm gear was manufactured from polyimide so no lubrication would be required. An anti-backlash worm was considered, but because of the added friction and low torque available from the motors, it was not used.

PROBLEMS ENCOUNTERED DURING DEVELOPMENT TESTING

1. It was found that the insertion-retraction system would not operate consistently. The unit would operate satisfactorily one afternoon, then the next morning with the same electrical configuration the unit would not give consistent operation. After investigation it was found the polyimide worm gear was hygroscopic, and an increase of humidity over 50% would cause interference between the worm and worm wheel. The qualification unit was installed into a thermal-humidity chamber and tested for both temperature and humidity tolerance. It was found that within $\pm 20^{\circ}$ C. (specified design temperatures) and below 30% relative humidity, no problems were encountered with the insertion-retraction system. Humidity in-flight will not be a problem.

2. The thickness of the dry lubricant applied to the spur gears was also a problem. The added thickness of the lubricant and the build-up of dry lubricant between the spur gear teeth caused binding between the spur gears. This problem was solved by brushing the spur gears with a soft wire brush and removing all dry lubricant except a thin film. Due to the light loading of the gears, no breakdown of the lubricant was experienced.

CONCLUSION

Three complete units of the polarimeter have been built, one prototype and two flight units. The prototype unit was used for development and qualification testing. One flight unit was delivered to GSFC in January of 1978 for integration into the flight experiment. The flight polarimeter has undergone system testing (vibration, vacuum, and optical alignment) and has met design requirements to this date.

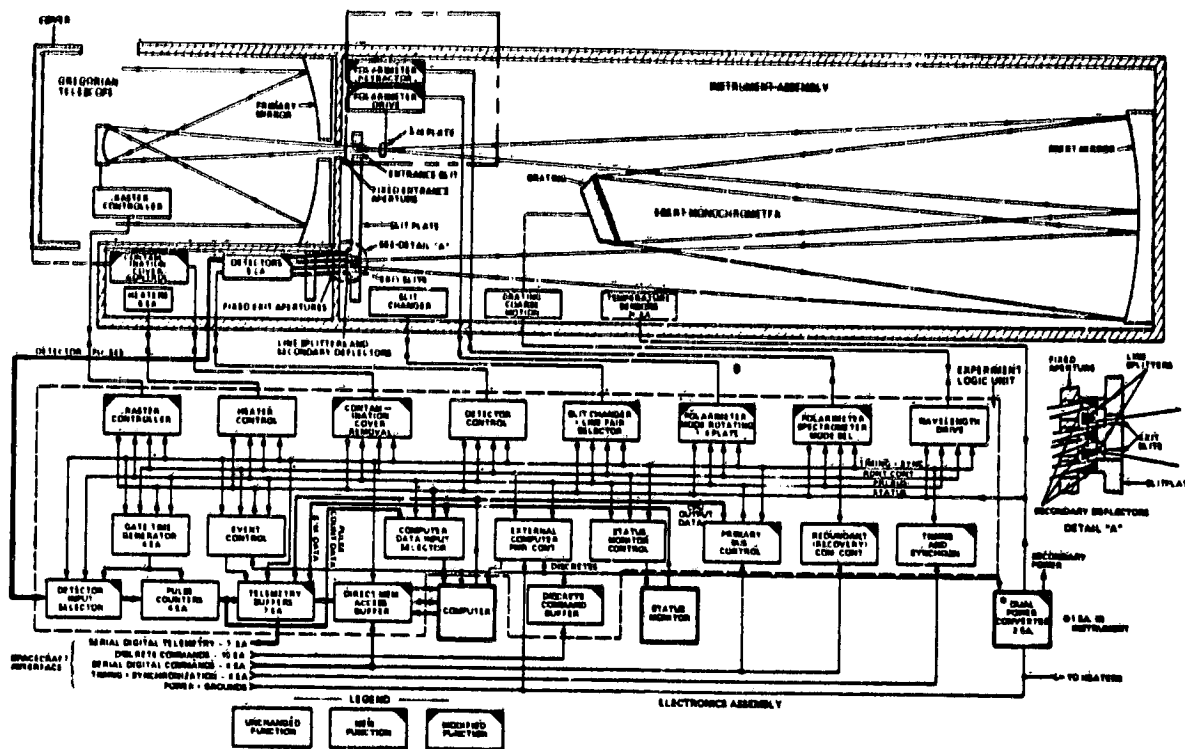

Figure 1.- Block diagrams of HRUVSP.

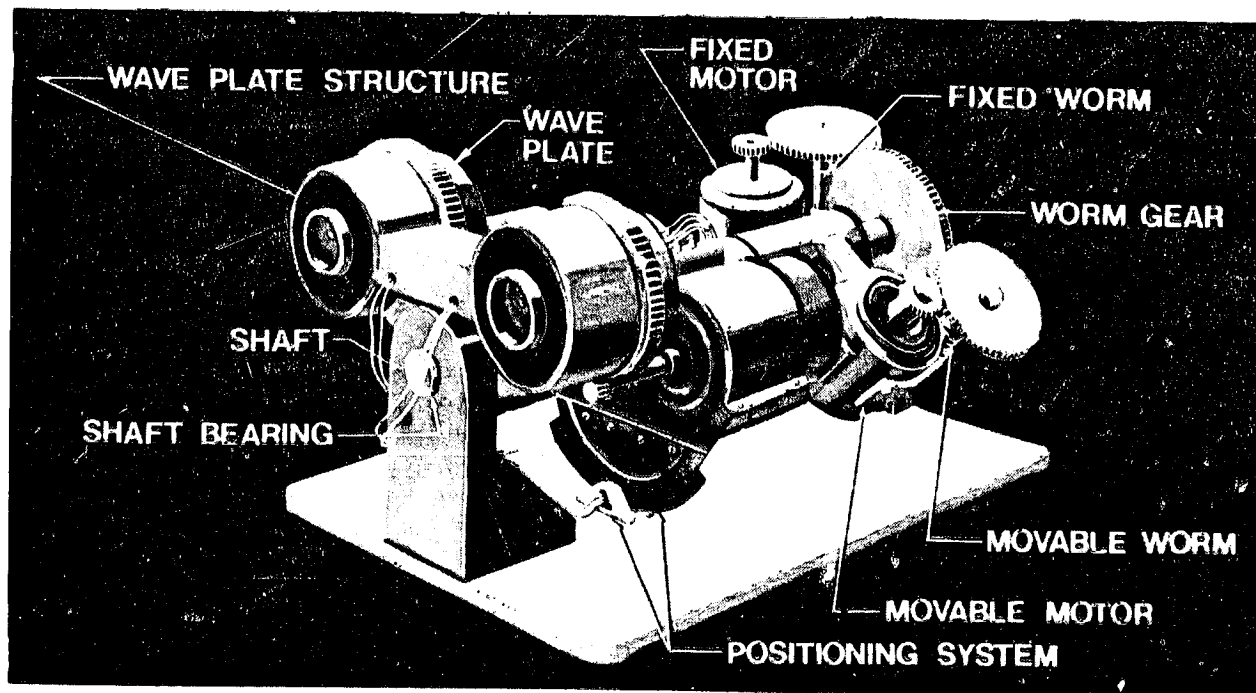

Figure 2.- Polarimeter, showing movable motor side.

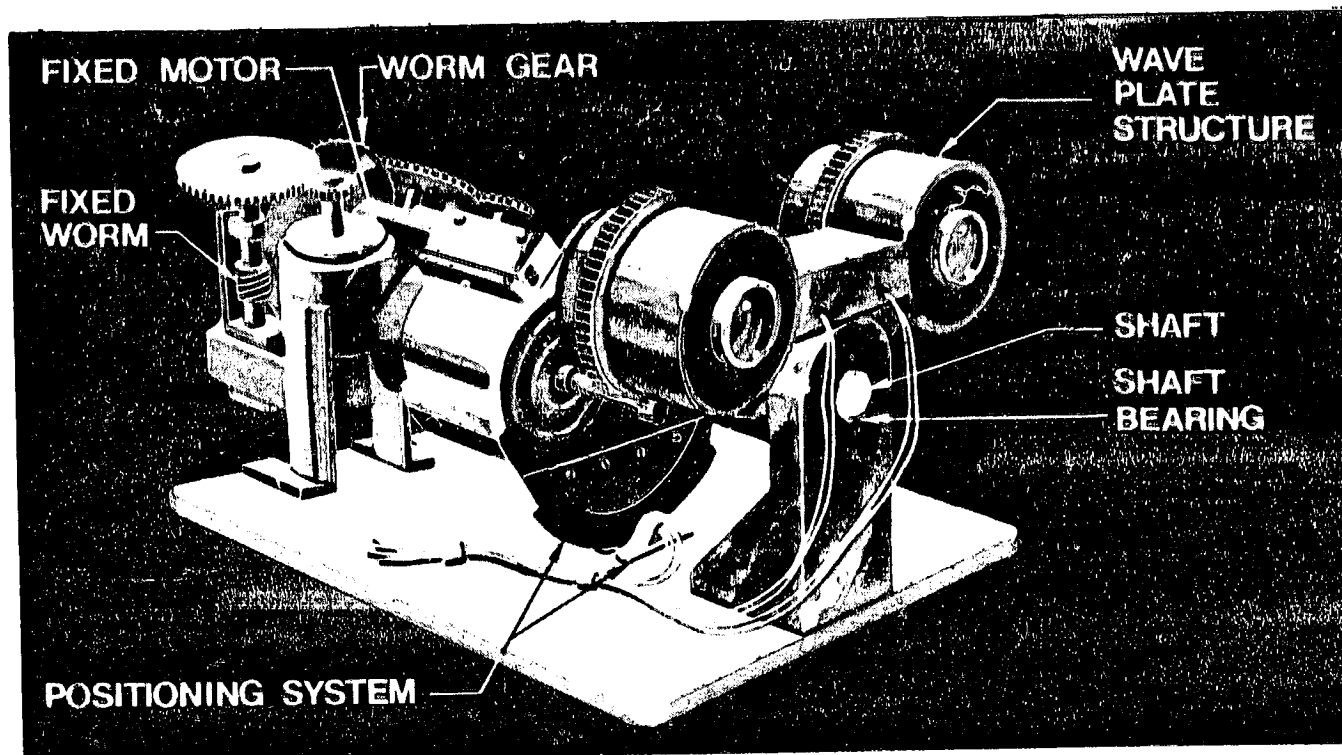

Figure 3.- Polarimeter, showing fixed motor side.

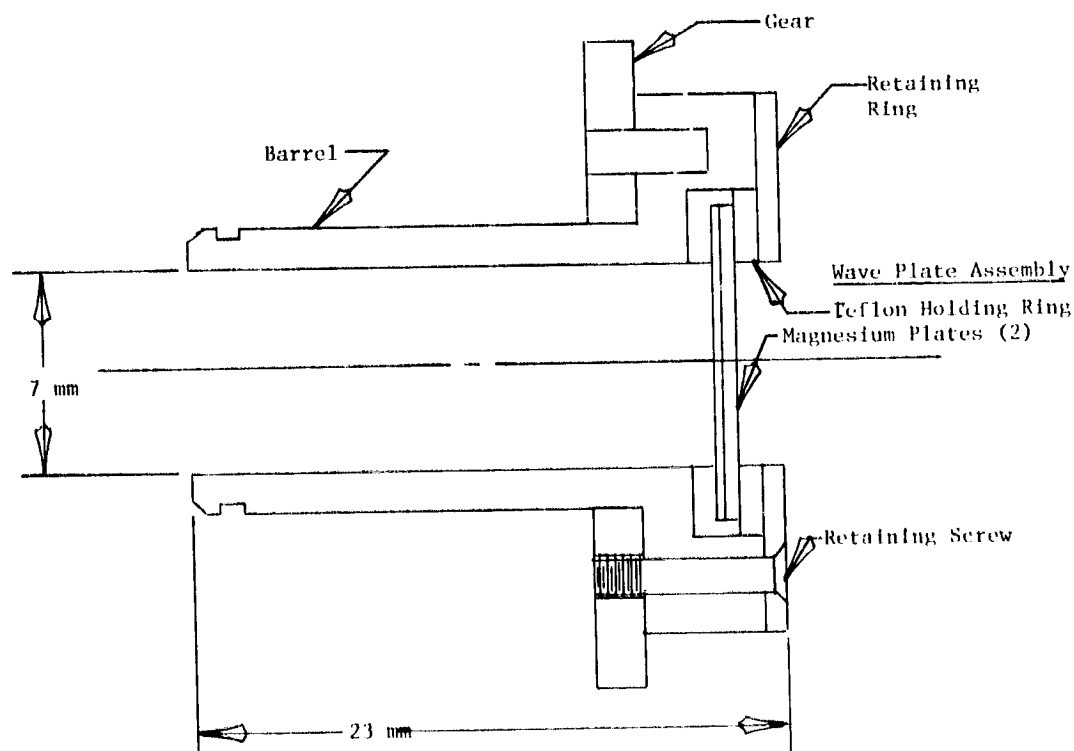
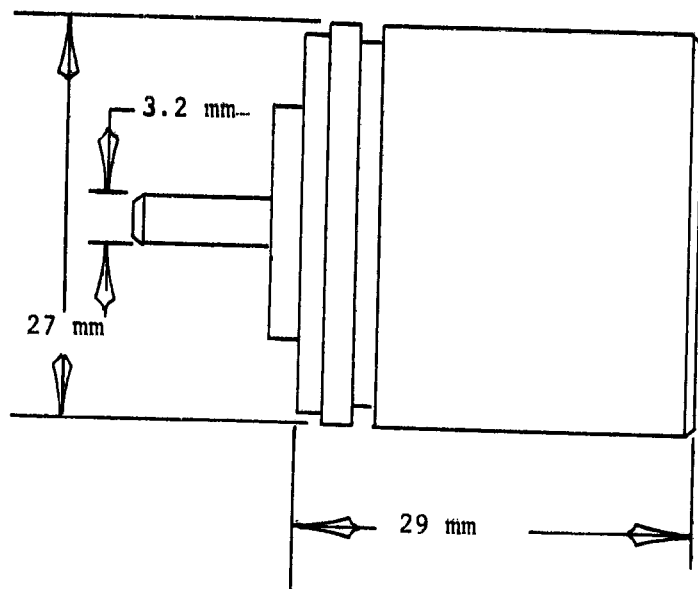

Figure 4.- Barrel assembly.



- (1) 90° Step Angle
- (2) 44.6 cm-gm Running Torque
(.62 oz-in)
- (3) Weight 96 gm (3.4 oz)

Figure 5.- Stepper motor.