

DESIGN EVOLUTION OF LARGE WIND TURBINE GENERATORS

David A. Spera
NASA Lewis Research Center
Cleveland, Ohio

SUMMARY

The design of large wind turbines of the horizontal-axis type has evolved rapidly during the past five years (fig. 1). Major changes have taken place in the structural and mechanical features of second generation wind turbines like the 2.5 MW Mod-2 (fig. 2), compared with first generation machines like the 200 kW Mod-OA (fig. 3) and 2.0 MW Mod 1. These changes have reduced the projected cost of electricity produced by second generation wind turbines to one-half that of first generation systems. Furthermore, wind machines like the Mod-2 have been designed to take advantage of the economies of mass production, so electricity generation costs are expected to eventually be cut in half again. Thus, during the past five years the goals of economy and reliability have led to a significant evolution in the basic design - both external and internal - of large wind turbine systems.

To show the scope and nature of recent changes in wind turbine designs, developments of three types are described: (1) system configuration developments; (2) computer code developments; and (3) blade technology developments. Developments in system configuration are shown by direct comparison of Mod-2 components (fig. 4) with equivalent elements in the earlier Mod-OA system (fig. 5). Significant economy has been achieved in blades by changing from lightweight but expensive aluminum aircraft construction to heavier but cheaper welded steel fabrication. As a result, rotor costs which were disproportionately high in the Mod-OA system now account for less than 25 percent of the Mod-2 cost of electricity (fig. 6). In addition, heavy and rigid elements like the Mod-OA tower, hub, and drive-train bedplate have evolved into lighter, more flexible, and more economical components in the Mod-2 machine.

Computer code development (fig. 7) has closely paralleled and supported configuration development. Special-purpose computer codes are now available for predicting the aerodynamic performance and structural dynamic behavior of large horizontal-axis wind turbines. Both proprietary and non-proprietary codes (with development and verification coordinated by LeRC) are listed in figure 8. Sources for detailed information on these codes are given in figure 9. Application of the newly-developed MOSTAS code is illustrated by comparing calculated dynamic blade loads with loads measured on the 100 kW Mod-0 test turbine (figs. 10 and 11).

Blade costs are one of the most important factors in determining the cost of generating electricity by wind power. Therefore, a wide variety of developments in blade design have occurred in the past five years, with the goal of reducing both initial cost and maintenance. Seven different blade designs are described (fig. 12) to illustrate the evolution which has taken place.

The trend is toward the use of materials and manufacturing processes that produce blades which are lower in relative cost but higher in relative weight, compared to the complete wind turbine.

While design improvements in second-generation wind turbine generators have significantly reduced the projected cost of electricity, further improvements are expected in the near future. The design of large wind turbines will continue to evolve, based on new technology and operating experience with present machines (fig. 13).

DISCUSSION

Q. What is the percentage cost associated with the Mod-1 blades and the Mod-2 blades?

A. The cost of the two Mod-1 blades is about 34 percent of the installed cost of the whole system. For the Mod-2 machine the blades represent about 25 percent of the capital investment. Now the bar chart I showed was based on the cost of electricity, which includes not only capital investment but also operation and maintenance costs. So there will be some small differences in the percentages.

The breakdown of weights and the approximate cost percentages will be given in some of the later presentations. There is hesitation, sometimes, on cost breakdowns because all the machines are not directly comparable. On the Mod-1 there are blades that are very expensive. On the Mod-2 the hub is an integral part of the blades, so we speak of rotors. Many times we try to compare Mod-1, Mod-OA and Mod-2 and it becomes a real problem. We would be happy to give you the actual dollar values behind the bar charts.

Q. At the time the requests for proposal went out for Mod-2, had DOE made the decision for a soft tower, or did the soft tower happen to win out?

A. The latter is the case. The soft tower was proposed by the Boeing Engineering and Construction Company which was the winner of the Mod-2 contract.

Q. As to all of these features that you outlined that contributed to the weight reduction, were they all fixed at the time the decision was made to go that way, or were some of them developed as the design process went along?

A. Some were developed during the conceptual and preliminary design processes. At the beginning of the Mod-2 effort, there were extensive trade studies conducted by Boeing: soft tower versus hard; two blades versus three blades; upwind rotor versus downwind. What you see here are the results of those studies.

DOE/NASA HORIZONTAL-AXIS WIND TURBINE GENERATORS

DESIGN		RATED POWER, KW	ROTOR CHARACTERISTICS				TOWER TYPE	COE, * UNIT 2 ¢/KWH
MOD	YEAR		DIAM, FT	HUB TYPE	LOCATION	WEIGHT, % TOTAL		
FIRST GENERATION								
0	'74	100	125	RIGID	DOWNWIND	4.7	STIFF	---
0A	'76	200	125	RIGID	DOWNWIND	5.1	STIFF	37
1	'78	2000	200	RIGID	DOWNWIND	5.6	STIFF	17
SECOND GENERATION								
2	'79	2500	300	TEETER	UPWIND	26.7	SOFT	8

*14 MPH SITE

Figure 1

Wind Turbine Configuration
MOD-2

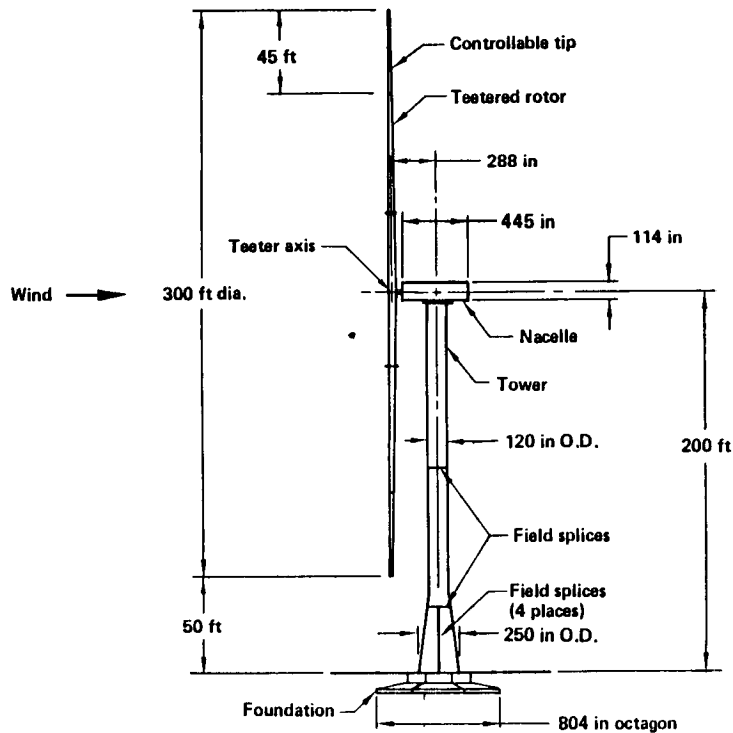

Figure 2

MOD-0A WIND TURBINE



Figure 3

2500 KW MOD-2 WIND TURBINE

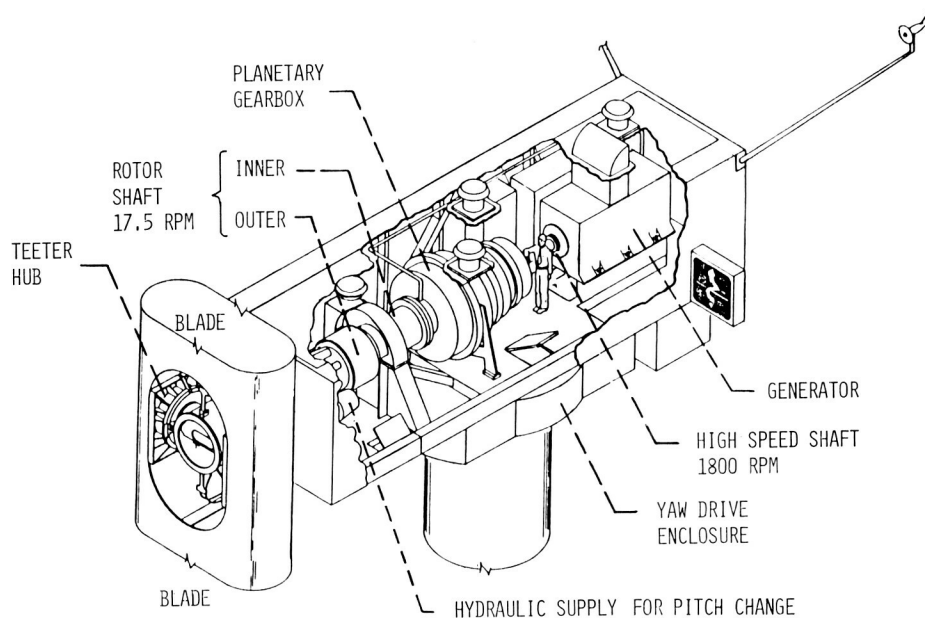

Figure 4

200 KW WIND TURBINE

MOD-0A

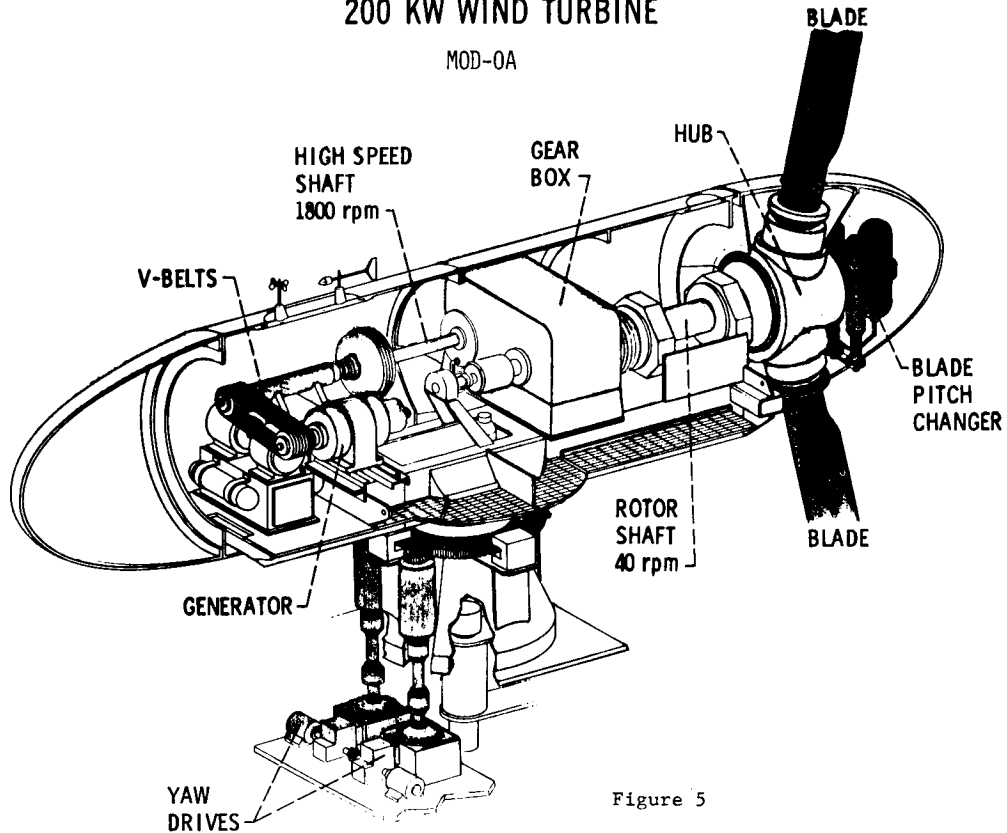

Figure 5

CONTRIBUTION OF DESIGN ELEMENTS TO COST-OF-ELECTRICITY

MOD-0A	47%	BLADES/HUB/PCM/CONTROLS
MOD-2	24%	BLADES/HUB/PCM/CONTROLS
	22%	GEARBOX/GENERATOR/SHAFTS/BEARINGS
	11%	TOWER/ACCESS
	11%	NACELLE/YAW DRIVE/YAW BEARING
	9%	FOUNDATION/SITE PREPARATION
	9%	OPERATIONS/MAINTENANCE
	8%	ASSEMBLY/CHECKOUT
	4%	OTHER (SPARES/EQUIP/PLANT)
	2%	TRANSPORTATION

Figure 6

WTG CHARACTERISTICS REQUIRE SOPHISTICATED ANALYSIS CODES

- LARGE FLEXIBLE ROTATING AIRFOILS, SUBJECT TO AEROELASTIC LOADS, COUPLED LOADS, AND DYNAMIC INSTABILITY
- LONG-LIFE STRUCTURES (UP TO 30 YR), SUBJECT TO FATIGUE
- ALL-WEATHER MACHINE, SUBJECT TO HIGH WINDS, SNOW, ICE, RAIN, DUST, TEMP EXTREMES, VANDALISM
- AIR LOADS ARE TRANSIENT, CYCLIC, AND STOCHASTIC
- EFFICIENT PERFORMANCE REQUIRED, SUBJECT TO CUT-IN, CUT-OUT, POWER CONTROL, YAW CONTROL, AND WIND PROBABILITY
- AUTOMATIC, UNATTENDED, REMOTE, FAILSAFE OPERATION REQUIRED, WITH LOW OPERATIONS AND MAINTENANCE BUDGET

Figure 7

STRUCTURAL DYNAMICS COMPUTER CODES FOR HORIZONTAL AXIS WIND TURBINES

1. NON-PROPRIETARY CODES

- AUTHOR: PARAGON PACIFIC, INC.
- MOSTAB-WT SINGLE BLADE, 1 DEGREE OF FREEDOM (DOF)
- MOSTAB-WTE LERC EMPIRICAL ADDITIONS
- MOSTAB-HFW 4 DOF ROTOR, PLUS TEETERING
- MOSTAS COMPLETE WTG SYSTEM; MOD-2 APPLICATION BY BEC

2. PROPRIETARY WTG SYSTEM CODES

- REXOR-WT LOCKHEED-CALIFORNIA
- GETSS GE SPACE DIVISION
- F-762 UNITED TECHNOLOGY RES. CENTER

3. VERIFICATION REQUIRED OF ALL CODES

- MOD-0 LOAD DATA
- MOD-2 1/20 SCALE WIND TUNNEL MODEL DATA

4. WEST WTG SIMULATOR

- HYBRID ANALOG/DIGITAL COMPUTER
- USES MOSTAS SOFTWARE
- SPEED INCREASE BY FACTOR OF 100

Figure 8

AVAILABLE STRUCTURAL-DYNAMIC CODES

CODE	SOURCE
MOSTAB-WT	Mr. Barry Holchin Mechanics Research Incorporated 9841 Airport Boulevard Los Angeles, CA 90045
MOSTAB-WTE	Dr. David A. Spera NASA-Lewis 49-6 21000 Brookpark Road Cleveland, OH 44135
MOSTAB-HFW	Mr. John A. Hoffman Paragon Pacific Incorporated 1601 E. El Segundo Boulevard
GETTS	Mr. Clyde Stahle General Electric Space Division Box 8661 Philadelphia, PA 19101
F-762	Dr. Richard Bielawa United Technologies Research Center East Hartford, CT 06108
MOSTAS	Mr. John A. Hoffman Paragon Pacific Incorporated 1601 E. El Segundo Boulevard El Segundo, CA 90245
REXOR-WT	Mr. Robert E. Donham Dept 75-21, Bldg. 360, Plant B-6 Burbank, CA 91520

Reference

"Comparison of Computer Codes for Calculating Dynamic Loads in Wind Turbines.
by D. Spera. NASA TM-73773 and DOE/NASA/1028/78-16, 1978.

Figure 9

TYPICAL EDGEWISE MOMENT LOAD MOD-0 WIND TURBINE BLADE SHANK

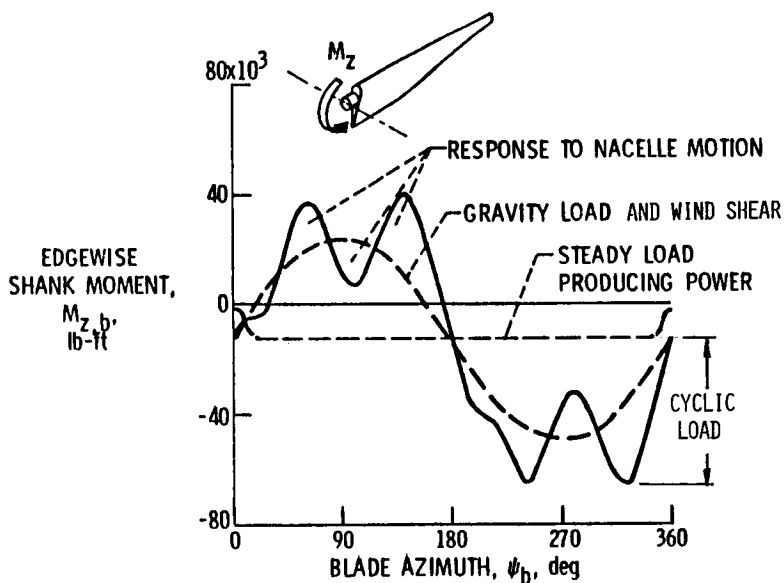

Figure 10

MOD-0 BLADE LOADS VS. YAW DRIVE STIFFNESS

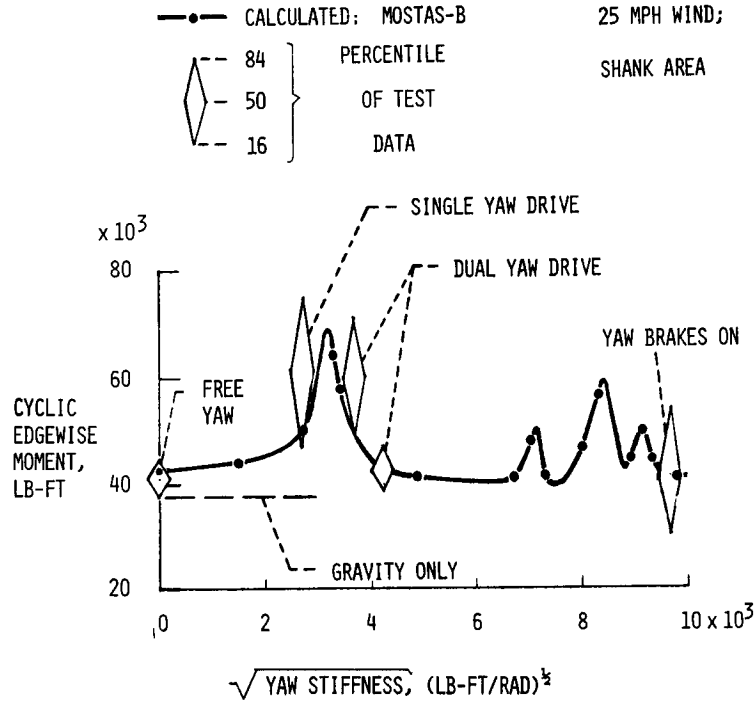

Figure 11

WTG BLADE CONFIGURATIONS

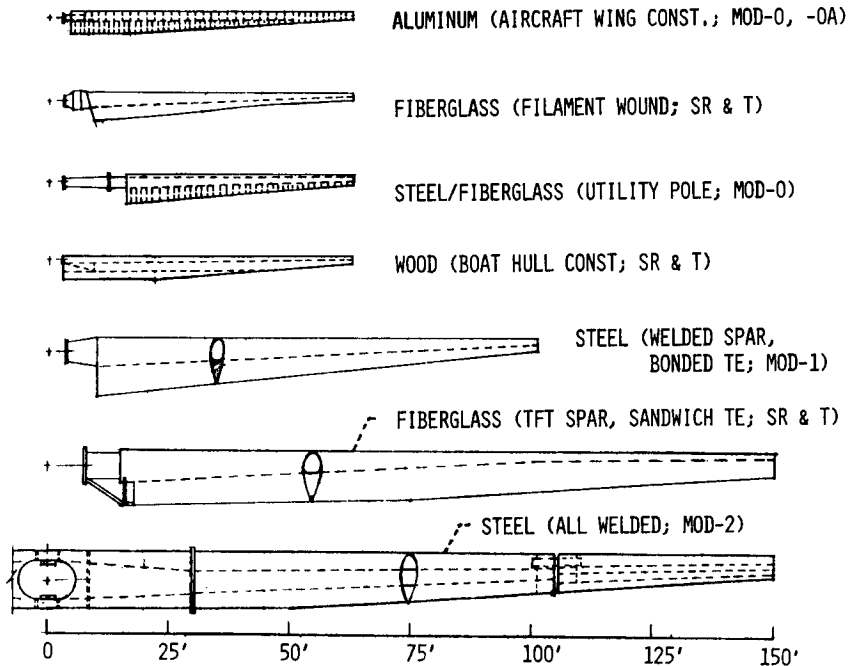

Figure 12

DESIGN OF LARGE, HORIZONTAL AXIS WIND TURBINE GENERATORS

1. WTG DESIGN REQUIRES SOPHISTICATED TECHNOLOGY BACKED BY SPECIALIZED ANALYTICAL TOOLS.
2. THESE TOOLS ARE AVAILABLE NOW, BUT THEY REQUIRE CONTINUOUS MAINTENANCE, VERIFICATION, AND UPGRADING.
3. DESIGN IMPROVEMENTS -- VALIDATED BY ANALYSIS AND MOD-0 TESTS -- HAVE:
 - REDUCED STRESSES IN MOD-0A WTG
 - REDUCED ROTOR COSTS IN MOD-2 WTG
 - CONTROLLED COSTS OF MOD-2 TOWER AND NACELLE
4. DESIGN REQUIREMENTS AND METHODS WILL CONTINUE TO EVOLVE, TO INCLUDE:
 - NEW MOD-0, -0A, AND -1 TEST DATA
 - MORE ANALOG SIMULATION AND GRAPHICS
 - MORE STATISTICAL DATA ON WIND LOADS
 - IMPROVEMENTS IN FATIGUE AND BUCKLING ANALYSES
 - DESIGN HANDBOOKS

Figure 13