

NUMERICAL PREDICTION OF 3-D EJECTOR FLOWS

Donald W. Roberts
Gerald C. Paynter

Boeing Military Airplane Development
Mail Stop 41-52
P.O. Box 3999
Seattle, Washington 98124

NUMERICAL PREDICTION OF 3-D EJECTOR FLOWS

Introduction

Ejectors are devices that present numerous complex flow problems to the design engineer. One obvious problem is that complex three-dimensional geometries can be of interest. Another problem is that local regions of supersonic flow can occur. Effects associated with three-dimensional boundary layers and regions of strong curvature can also be important, as shown in Figure 1. The performance of the ejector is a strong function of the mixing process between the primary nozzle flow and the secondary flow. The turbulence levels and the turbulence-driven secondary flows can influence the mixing process and thus the ejector performance. The design engineer is confronted with the difficult task of managing a number of complex flow phenomena when designing an ejector. The current design procedure, based on parametric model scale testing, can be substantially improved through the use of available flow analyses to reduce the required test matrix and to improve the designer's understanding of flow phenomena which have a strong influence on ejector performance.

In the traditional or test based design procedure, parametric model scale tests are conducted to obtain gross performance parameters, such as mass flow rates and thrust. These tests are not aimed at getting flow details and they are thus usually of little use in providing an understanding of the complex ejector flow phenomena. In this approach, a design concept and simple analysis are used to define a baseline geometry. Important geometric features are varied parametrically to obtain a test matrix. These tests are often very expensive which limits the number of parameters that can be examined in a given study. Without detailed flowfield measurements during these tests, one really doesn't understand what flow phenomena are important to the performance of the ejector. Another problem with this approach is that model scale test results may not scale well. This is often because of the poor control of the

upstream flow conditions in the model test. The final result of a test based approach is typically a design that is not optimum and not well understood. This can lead to unpleasant surprises in the full scale validation phase of the design process.

The approach advocated in this paper is based on the use of parametric flow analysis rather than parametric model scale testing* to support the design of an ejector system. This approach offers a number of potential advantages. Analysis allows one to closely examine the details of the flow. Analyses can be fast and inexpensive compared to parametric model scale tests. One can afford to look at a larger number of parameters, can vary them parametrically over a wider range, and can precisely control the flow conditions. Experimental testing may still be used, but its main purpose would be to confirm the analysis for just the final design. This can give us more confidence in the design, and enhance the chance for success.

Analysis Objectives

The objective of this paper is to describe how available 3-D flow analyses might be applied to the design of ejectors. This problem can be subdivided into several key analysis elements. These are numerics, turbulence modeling, data handling and display, and testing in support of analysis development.

With the recent developments in numerics and computer technology, the capability exists to develop a useful analysis based design procedure. There are a number of numerical tools available; many of these have been developed in the basic research centers such as Ames and other Government laboratories and in the private sector. The analysis problem can be simplified by looking at the ejector flow. The flow can be naturally divided into an elliptic region that is basically inviscid and a

* A model scale test of a given configuration may be desirable to validate the analysis. In contrast to the test based approach, however, this test must provide detailed flow properties to be useful for analysis validation.

parabolic or partially parabolic region which is dominated by viscous effects. The idea then is to use available flow analysis tools and couple them together to yield one analytical tool for analyzing the ejector flow. Another important feature in the numerics category is the use of automated computational mesh generation. To keep the computational costs within reason, one must make optimum use of the available computational mesh. This can be accomplished most efficiently by tailoring the mesh to the geometry and to the flow.

Turbulence modeling can often make or break an analytical method. We advocate the use of the Bradshaw classification system (Ref. 1) for complex flows. It is based on the selection of a turbulence model for the actual turbulence phenomena that occur in the flow as opposed to selecting or developing a model for the geometries that are present. Two-equation turbulence models for mixing type flows have been shown to be a good compromise between accuracy and simplicity (Ref. 2, 3, 4). These models also have direct extensions to more complex models such as the algebraic Reynolds stress models which show promise for analyzing flows with turbulence-driven secondary flows (Refs. 5, 6).

Data handling and display is important since a large computer program is going to provide a vast amount of output. One wants to be able to look at it rapidly and make quick decisions. Boeing uses dedicated mini-computers with the associated video hardware which allow one to look at large amounts of data in a short amount of time.

Testing in support of the analysis development will always be necessary to provide a means for validating the analysis. Government sponsored bench mark experiments which would be valuable for developing an improved understanding of turbulent flows could lead to better turbulence models. One could also obtain the detailed flow properties necessary for analysis validation from applied technology experiments by just adding more instrumentation.

Coupling Procedure

The basic coupling procedure proposed in this paper would divide the flow into four basic regions, Figure 2. Three of these regions are dominated by viscous effects; the other region is essentially inviscid. Initially, boundary layers on the shrouds would be neglected. An ejector system design study usually assumes a given engine operating at a "match point" or given operating condition. Therefore, the flow at (1) is fixed, and it is assumed that the nozzle ejector geometry can be varied such that the engine follows a known operating line. In other words the engine must be able to pass the mass flow rate dictated by the operating line. One must solve for the viscous flow in Region I to obtain flow conditions at B. Assuming that an initial plume shape can be determined, one can solve for the flow in the inviscid region (Region IV) to get a match at B. Then the mixing internal flow (Region II) is solved with a parabolic analysis. Finally, the jet flow (Region III), which has boundaries that overlap into the inviscid region such that the flow properties can be used for boundary conditions, is predicted. From the jet calculation a new plume shape is derived. This procedure is then iterated until a converged solution is obtained. Coupling procedures similar to this have been successfully developed. Several inviscid analyses are available for predicting the flow in Region IV. This analysis component could be a linearized potential flow code such as PANAIR or the full transonic potential flow codes which are being developed currently. Boeing has developed two 3-D parabolic viscous flow analyses. One of these has been well-documented for mixing types of flows (Refs. 3, 4). The other code has been developed for the analysis of parabolic flows in ducts with arbitrary cross sections (Ref. 7). This code solves the compressible three-dimensional parabolized Navier-Stokes equations. The Boeing viscous codes use a two-equation turbulence model which can be directly extended to the algebraic Reynolds stress model. The flow equations have been transformed and are solved in a body fitted coordinate system which allows one to tailor the mesh to the geometry and to the flow. The parabolic analysis could be extended to a partially parabolic analysis which has the fully elliptic pressure coupling necessary when strong

curvature of the flow is present (Ref. 8). This code has been used to predict turbulent flows in diffusers which transition in cross section from rectangular to round.

Our experience has shown that parabolic analyses are useful and accurate for predicting mixing and jet flows. A flow that is similar to the mixing process you find in ejectors is the mixing between a primary flow and a fan flow, Figure 3. The predictions (Ref. 3) of the total temperature contours at the exit plane are shown in Figure 4. The peak values of these total temperature contours show good agreement with the experimental data. The one exception is that the contours in the experimental data tend to be round where the predicted ones are more elliptical. This was also indicated in the model scale results. This difference in the shape of the total temperature contours could be due to a problem with initial conditions in the predicted results or it could be a problem with the turbulence model. An algebraic Reynolds stress model was recently developed which could yield a better simulation of this effect. Another example of a complex mixing flow is the interaction of the residual swirl in the turbine exhaust with the turbine support strut which generates a distorted flow in the exhaust jet. This asymmetric nozzle flow was not expected in an axisymmetric nozzle, but it is what was found experimentally. The prediction of this flow using our parabolic analysis provided good agreement with the experimental data, Figure 5.

The 3-D viscous jet analysis has been applied to several complex free jet flows (Ref. 4). One of these, the interaction of the three jets on a 727, also has an interaction with the ground plane, Figure 6. Figure 7 presents the predicted velocity contours which show the merging of the jets and the interaction with the runway. It is a biplaner solution so it is only necessary to look at one and a half jets. The jet peak velocity decay is compared with the only experimental data that is available in Figure 8. The prediction falls along the line of the experimental data. If this flow is computed assuming an axisymmetric single free-jet, the peak velocity decay of the jet is missed by a large margin. The 3-D analysis was essential in this particular case.

Conclusions

3-D flow analysis technology exists that could be used to develop an analysis based design procedure for ejectors. The key 3-D viscous and inviscid component analyses are currently available. The coupling procedures for these analyses are well understood, and they have been used in the past. A primary requirement now is to demonstrate computational efficiency so that the overall analysis procedure can be used for design work. The ability to select a suitable turbulence model or models may prove to be the factor which controls the effectiveness of an analysis based design procedure for ejectors.

References

1. Bradshaw, P., "Review - Complex Turbulent Flows", Journal of Fluids Engineering, Trans. ASME, June 1975.
2. Launder, B., and Spalding, D. B., "The Numerical Computation of Turbulent Flows", Computer Methods in Applied Mechanics and Engineering, 3, 269-289, 1974.
3. Birch, S. F., Paynter, G. C., Spalding, D. B., and Tatchell, D. G., "Numerical Modeling of 3-D Flows in Turbofan Engine Exhaust Nozzles", J. of Aircraft, 15, 8, 1978.
4. Barton, J. M., Birch, S. F., Paynter, G. C., and Crouch, R. W., "An Experimental and Numerical Study of Three-Dimensional Turbulent Jets", AIAA Paper No. 78-994, 1978.
5. Tatchell, D. G., "Convection Processes in Confined Three-Dimensional Boundary-Layers", Ph.D. Thesis, University of London, July 1975.
6. Gessner, F. B., and Emery, A. F., "A Reynolds Stress Model for Turbulent Corner Flows -- Part I: Development of the Model", Journal of Fluids Engineering, 261-268, June 1976.
7. Roberts, D. W., and Forester, C. K., "Parabolic Procedure for Flows in Ducts with Arbitrary Cross-Sections", AIAA Journal, Vol. 17, No. 1, January 1979.
8. Pratap, V. S., "Flow and Heat Transfer in Curved Ducts", Ph.D. Thesis, Imperial College, University of London, 1975.

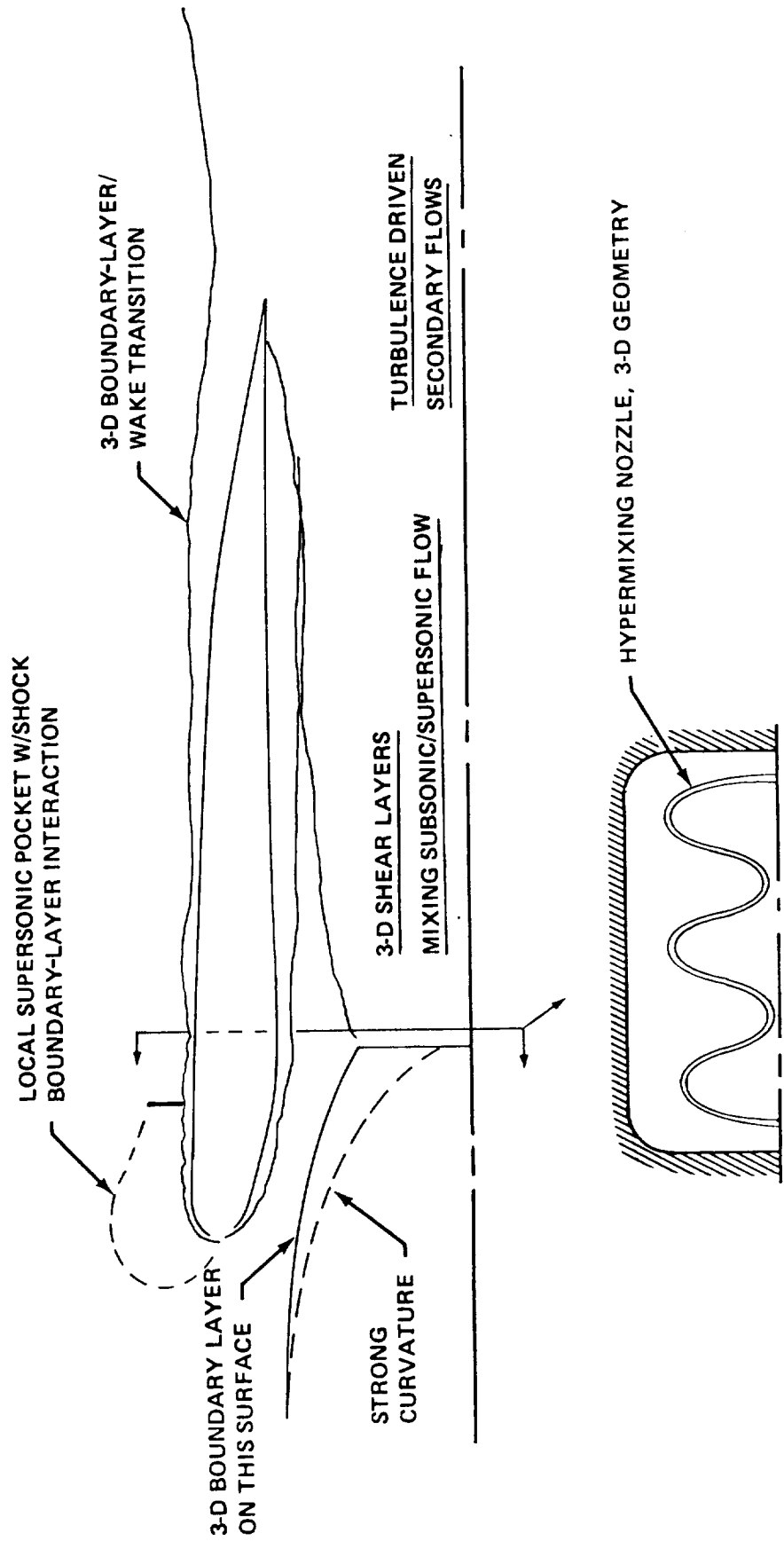
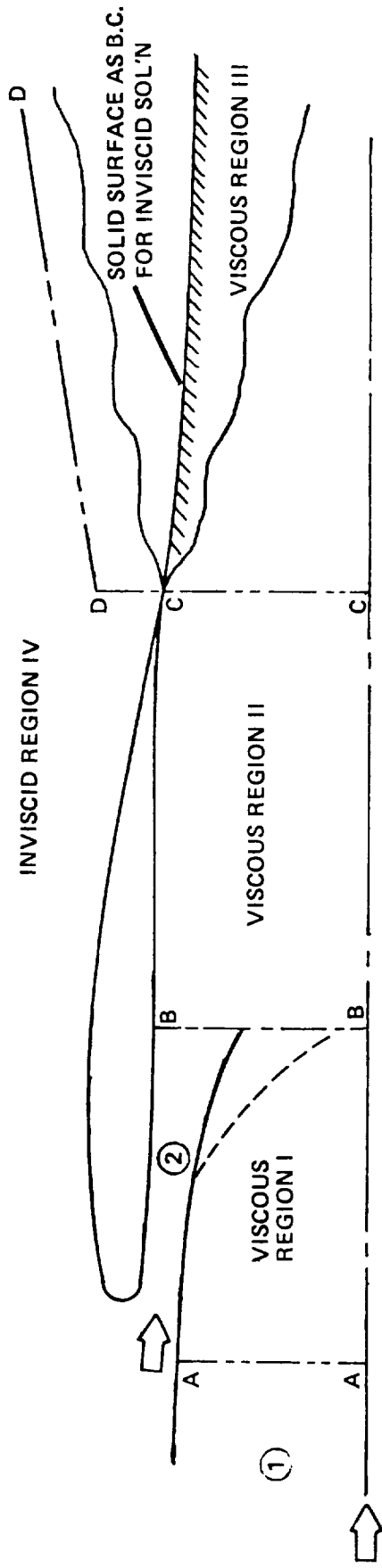

Figure 1. Flow Problems Associated with 3-D Ejectors.



ASSUMPTIONS

- FLOW (1) IS KNOWN AND FIXED
- THE ENGINE NOZZLE GEOMETRY IS ADJUSTABLE

COUPLING PROCEDURE

1. ASSUME PRIMARY NOZZLE EXIT AREA – SOLVE REGION I
2. SOLVE REGION IV, ITERATING MASS FLOW (2) UNTIL PRESSURE CONTINUITY BETWEEN VISCOUS AND INVISCID SOLUTIONS IS OBTAINED IN PLANE B - B
3. SOLVE VISCOUS REGIONS II & III ITERATE STEPS 1, 2 & 3 UNTIL CONVERGENCE IS OBTAINED FOR PROPERTIES ON LINES C-D & D-D

Figure 2. Coupling Procedure for Viscous and Inviscid Flow Regions.

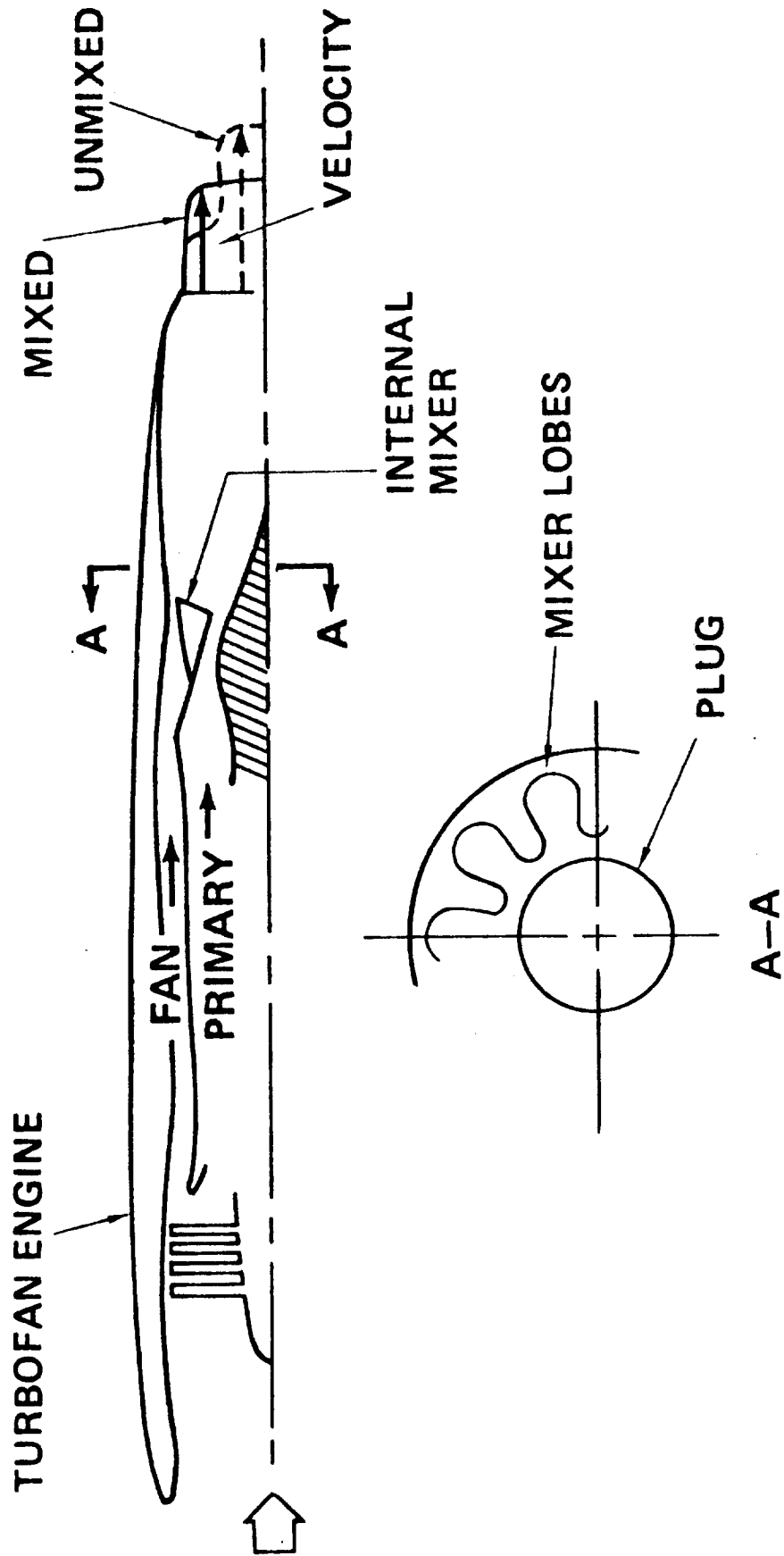

Figure 3. Cross-Section of Turbofan Engine with Lobed Mixer.

NOZZLE EXIT TOTAL TEMPERATURE MAP
FROM TEST OF THE FULL SCALE
FORCED MIXER

$P_{tP}/P_A = 1.791$
 $P_{tF}/P_A = 1.789$
 $T_{tP}/T_{tF} = 2.148$

CONTOUR	T_t/T_{tF}
1	1.90
2	1.80
3	1.70
4	1.60
5	1.40
6	1.20
7	1.00

COMPUTED NOZZLE EXIT TOTAL
TEMPERATURE MAP FOR THE FULL
SCALE FORCED MIXER, CASE 5 . REF. 3



Figure 4. Experimental and Predicted Total Temperature Contours.

PREDICTED AND MEASURED VELOCITY CONTOURS
AT THE EXIT PLANE OF A JT8D-17 ENGINE

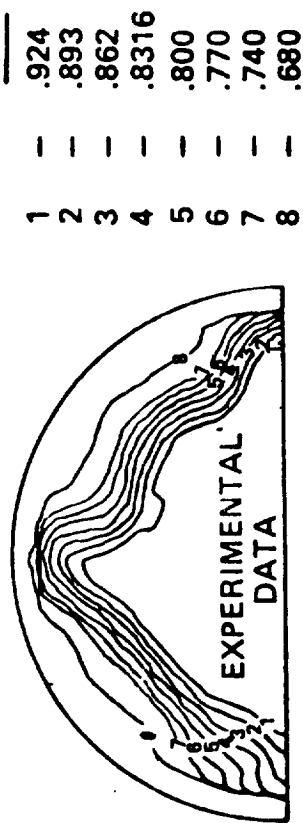

CONCLUSION:

INTERACTION BETWEEN ENGINE SWIRL
AND TURBINE SUPPORT STRUT SETS UP
AN ASYMMETRIC NOZZLE EXIT FLOW

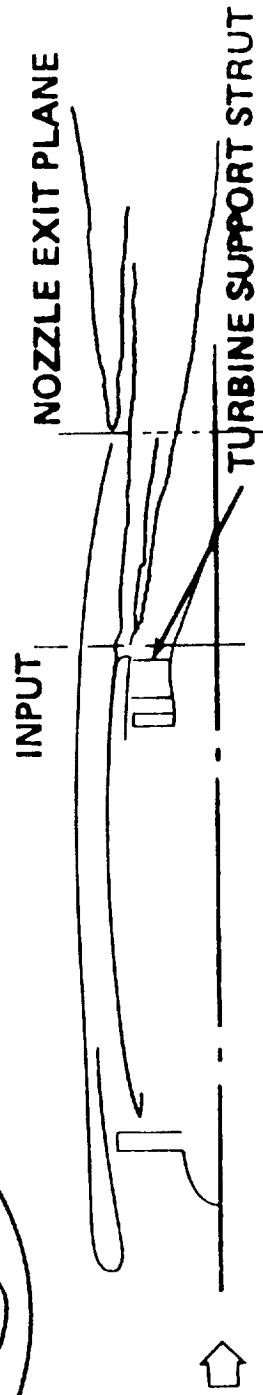

Figure 5. Experimental and Predicted Velocity Contours for Asymmetric Nozzle Flow.

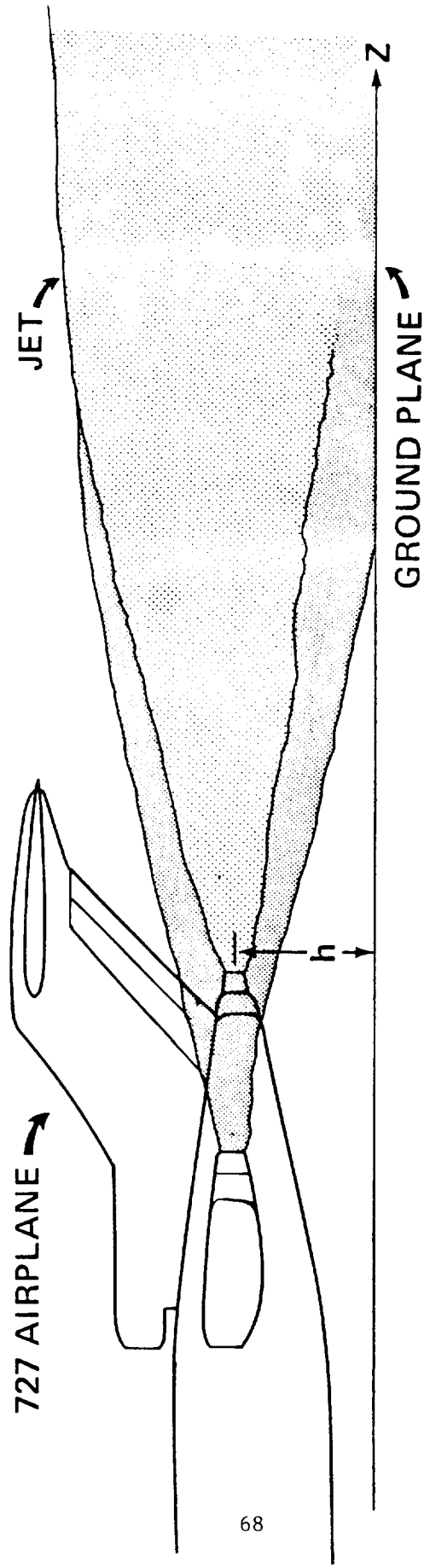

Figure 6. Schematic of 727 Jet Exhaust Interacting with Runway.

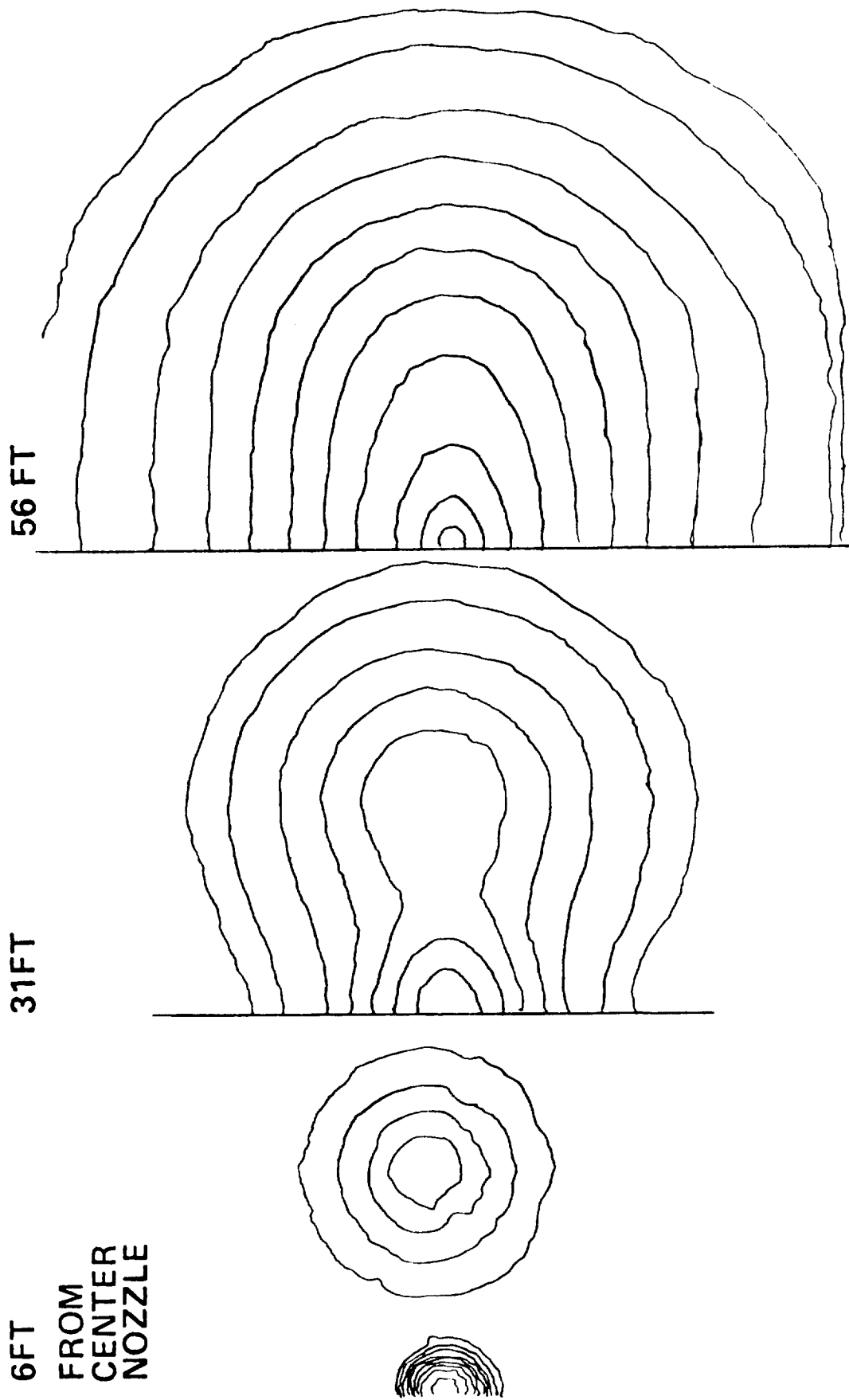

Figure 7. Predicted 727 Jet Exhaust Development.

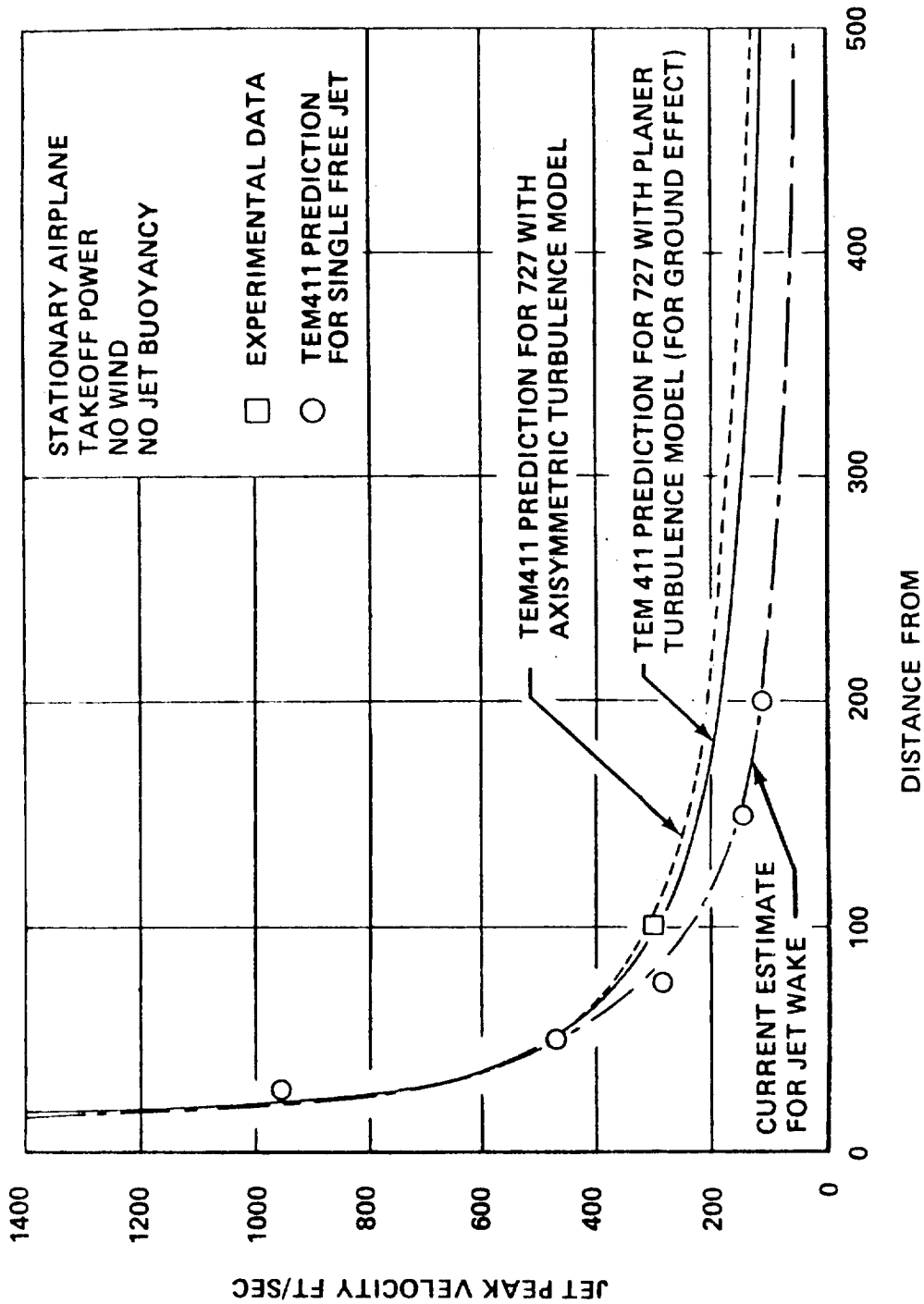

Figure 8. Predicted and Experimental peak Velocity Decay for 727 Jet Exhaust on Runway.