

HYPERSONIC STRUCTURES: AN AERODYNAMICIST'S PERSPECTIVE

or

(ONE MAN'S DREAM IS ANOTHER MAN'S NIGHTMARE)

J. D. Watts, L. R. Jackson, and J. L. Hunt  
NASA Langley Research Center

INTRODUCTION

From the title of this paper, one might infer that the age-old tradition of compromise between aerodynamicists and structural designers was going to be treated with some degree of levity. We hope you have not been misled, as the relationship between aerodynamicists and structures research and design engineers is indeed a very serious matter. And, the faster our aircraft become, the more serious the relationship becomes.

I think it is a well-established fact that hypersonic aerodynamicists can generate more structural problems in five minutes than the structural designer can solve in five years. However, the cooperation of engineers in the aerodynamics, propulsion, and structures fields is the only way aircraft get built. Hypersonic aircraft are going to require closer cooperation and more extensive trades and compromises than any other aeronautical task we've had to face.

## X-15 RESEARCH AIRPLANE

(Figure 1)

In the 1960's, when hypersonics was still a highly active discipline in the aeronautical engineering field, the X-15 research airplane shown in Figure 1 was successfully probing the "thermal thicket" and proving beyond a shadow of doubt that we could indeed build a metal airplane structure which would withstand the rigors of Mach 6 flight and temperatures of 1000 K (1340°F). The designers may not have been able to predict thermal stresses extremely well with the primitive tools they had then, but they did have a high respect for thermal loads. Their design held up under those thermal stresses, even if there were a few wrinkles and buckles here and there on the airframe after the 200-flight program. I would venture to say that if we had had today's powerful finite element analysis tools to check the X-15's thermal stresses in 1962, we would probably have been too scared to make another flight.

# X-15 RESEARCH AIRPLANE



Figure 1

## HYPersonic VEHICLE DESIGN STUDIES OF THE 1960's

(Figure 2)

You may recall that during the same period of time that the X-15 airplane was flying, a number of advanced hypersonic vehicle systems studies were going on and the mission planners, the aerodynamicists, and the propulsion engineers were able to generate a mountain of problems for the structures engineers to solve. Figure 2 shows two vehicle concepts studied during the 1960's. The vehicle on the left is the Air Force's DynaSoar, a small manned boost-glide craft which was to have attained suborbital speeds prior to making a gliding reentry. The large vehicle on the right was the Air Force's Aerospaceplane, a horizontal take-off single-stage-to-orbit airplane which used multimode propulsion and separated its own oxygen out of the atmosphere while flying at hypersonic speeds. The stored LOX was then used with liquid hydrogen fuel to power a rocket which boosted the vehicle into orbit.

# HYPERSONIC VEHICLE DESIGN STUDIES OF THE SIXTIES

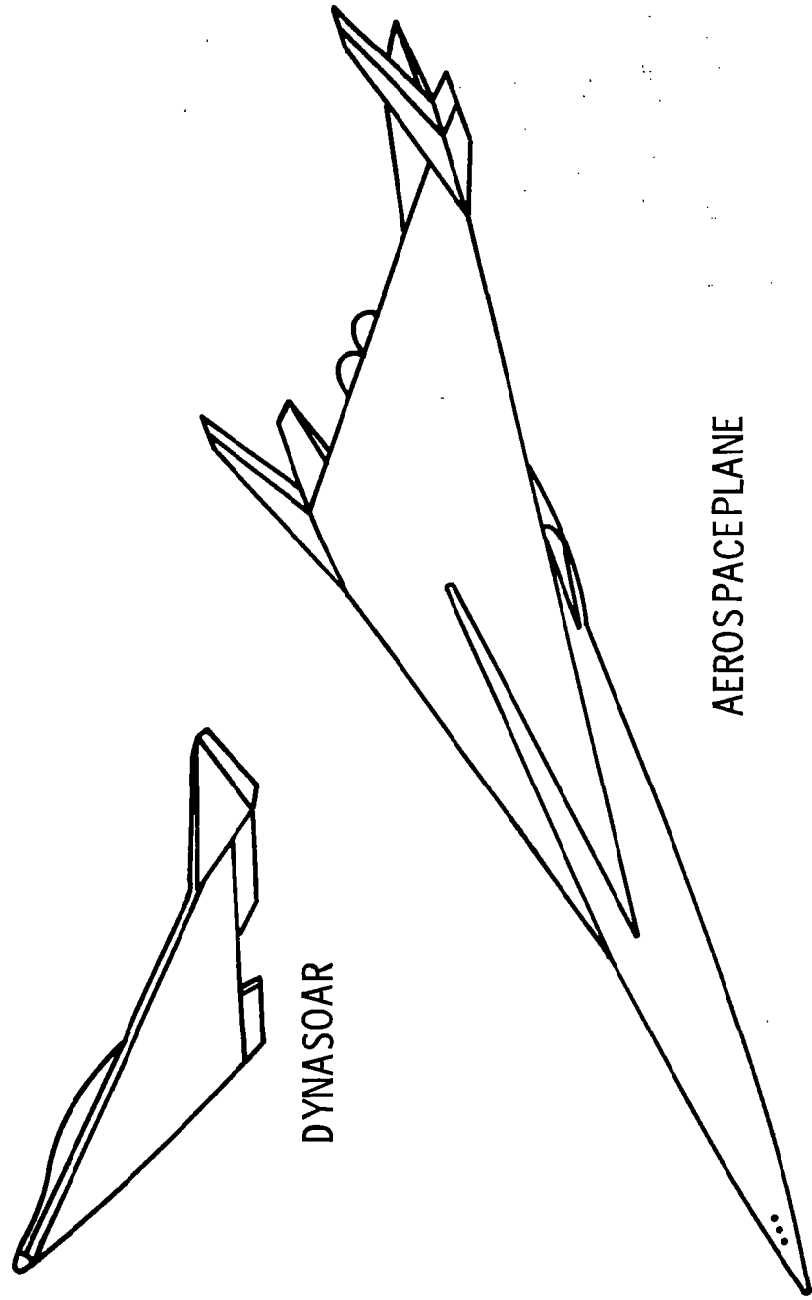

DYNASOAR

AEROSPACEPLANE

Figure 2

## HYPERSONIC VEHICLE STRUCTURES

(Figure 3)

The basic structural approaches used with the two vehicles in the previous figure are shown in Figure 3. The DynaSoar wing structure was composed of Rene'41 panels on both surfaces supported by the load-bearing structure, which was a pin-jointed truss. The lower surface heat shields were coated refractory metal, which covered a fibrous insulation. The Aerospaceplane fuselage structure was a titanium integral liquid hydrogen tank. The tank was covered with an evacuated multilayer insulation and the whole system was protected by a stand-off refractory metal or nickel alloy heat shield, depending on the local surface temperature.

Through the process of attacking extremely difficult missions with out-of-reach technology, the aircraft industry was able to thoroughly convince the military sponsors of hypersonic technology development that hypersonic systems were impractical and far too costly. This was, as you will remember, the beginning of a long dry spell in hypersonics. Except for a few lingering groups of researchers here and there, hypersonic aeronautics ceased to exist for over 10 years. It is good to know that one of the research areas that has survived has been structures.

# HYPERSONIC VEHICLE STRUCTURES

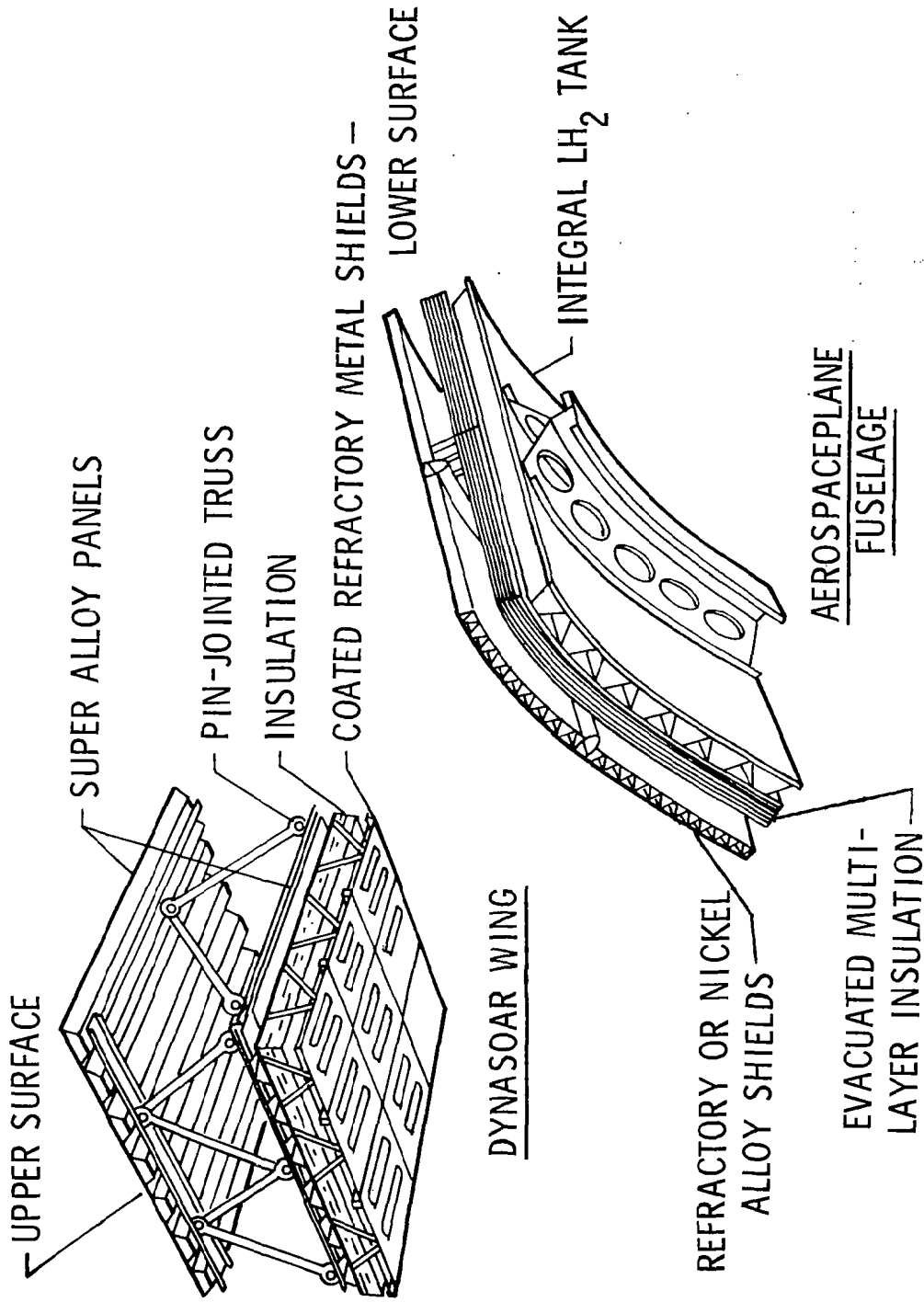

Figure 3

## THERMAL PROTECTION SYSTEMS OF THE MANNED SPACE PROGRAM

(Figure 4)

When hypersonic aeronautics received the coup de grace in the late 1960's, the national aerospace focus was on the manned space program. One might have assumed that the structural problems associated with reentry would be considerably more difficult than those addressed earlier in aeronautics. However, an interesting thing happened. A means of coping with reentry heating was developed which drastically reduced the temperature environment of the structure. The next figure shows the two basic types of space reentry vehicles developed in the manned space program over the past 20 years. The first was the capsule-type vehicle with an ablative heat shield. This type represents Mercury, Gemini, and Apollo. For these vehicles, the structural problems previously identified with high-speed flight were essentially sidestepped through the application of ablatives. This approach effectively kept the pressure off the structural designers for some time. Then came the Space Shuttle which puts together the nonmetallic heat shield technology with an aircraft-type reentry vehicle. Again, the structural designer's task was relieved of the high-temperature problems by a liberal application of external insulation.

I certainly hope that the remaining experts in the advanced structural technology arena have not been lulled to sleep by past trends in reentry vehicle design because the airplane people are once again getting busy in the wind tunnels with some far-out and some not-so-far-out ideas, all of which will undoubtedly have serious structural implications. Most of these structural problems are not likely to be solved through the use of ablatives or available external insulators.



# THERMAL PROTECTION SYSTEMS OF THE MANNED SPACE PROGRAM

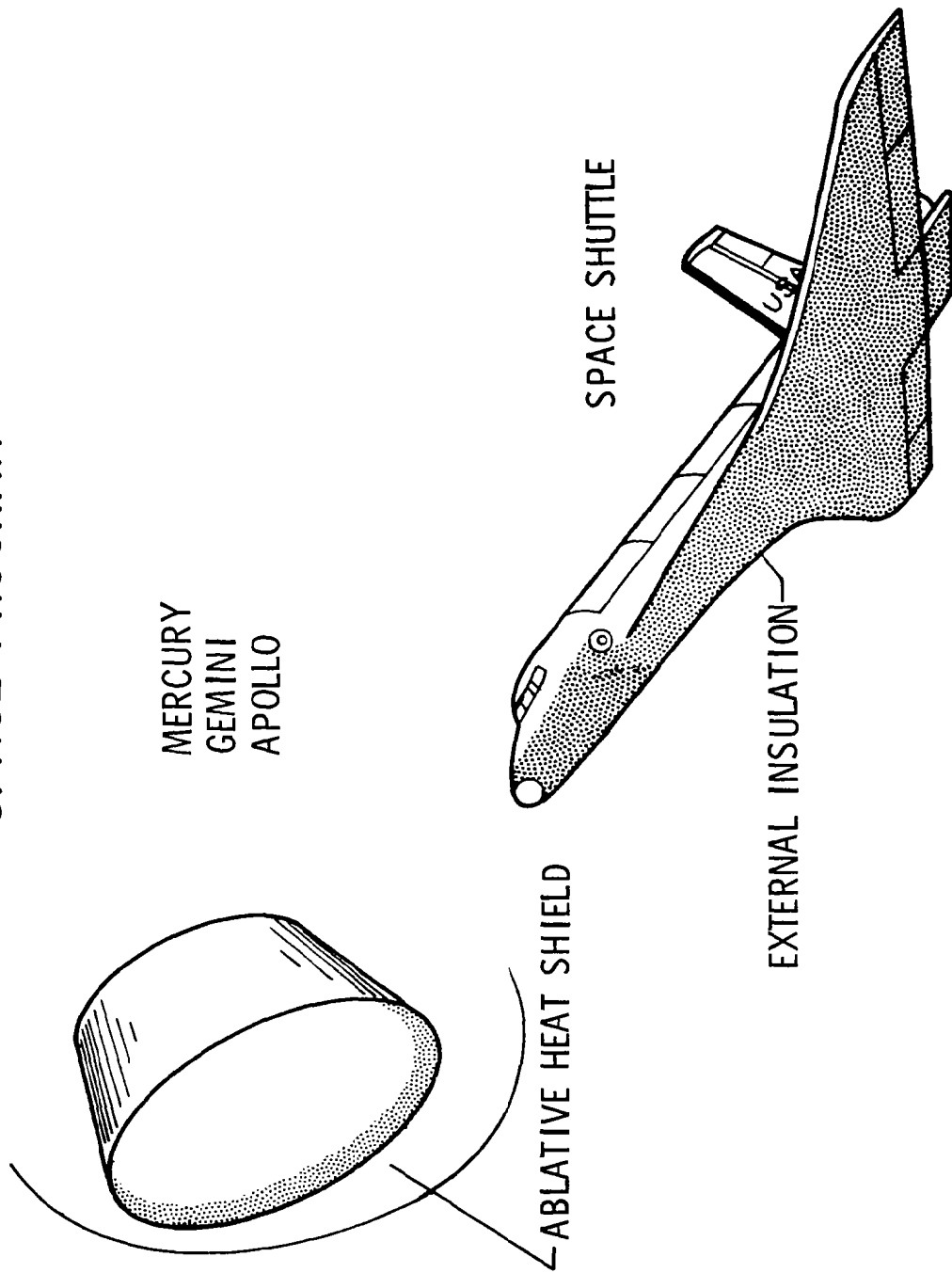

Figure 4

## VEHICLE CATEGORIES NOW UNDER STUDY IN HYPERSONIC AERODYNAMICS

(Figure 5)

The primary objective in our current hypersonic aerodynamics program is to develop a broad experimental data base for three classes of vehicles. These three categories of hypersonic vehicles are shown in Figure 5. First, we are currently studying the airbreathing space launch system shown on the left. The vehicle shown is a two-stage system which utilizes turbojet propulsion in twin boosters up to the staging Mach number of about 3.0. The middle vehicle in the figure represents the second class under study, hypersonic cruise missiles. We're working in the Mach 4 to Mach 8 speed range with these missile configurations. The third category, shown on the right, is the cruise aircraft which may someday find applications in both military and civilian missions. The speed range we're emphasizing is Mach 4 to 6 and the fuels being considered include JP, LH<sub>2</sub>, and a combination of both.

We are in the early stages of our aerodynamics research program now but already we are seeing several challenging structural problems starting to precipitate out.

# VEHICLE CATEGORIES NOW UNDER STUDY IN HYPERSONIC AERODYNAMICS

## AIRBREATHING LAUNCH SYSTEMS

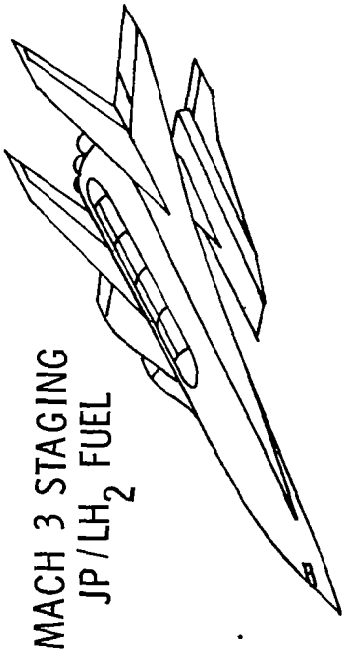

MACH 3 STAGING  
JP / LH<sub>2</sub> FUEL

## HYPERSONIC MISSILES



MACH 4-8 CRUISE  
STORABLE FUEL

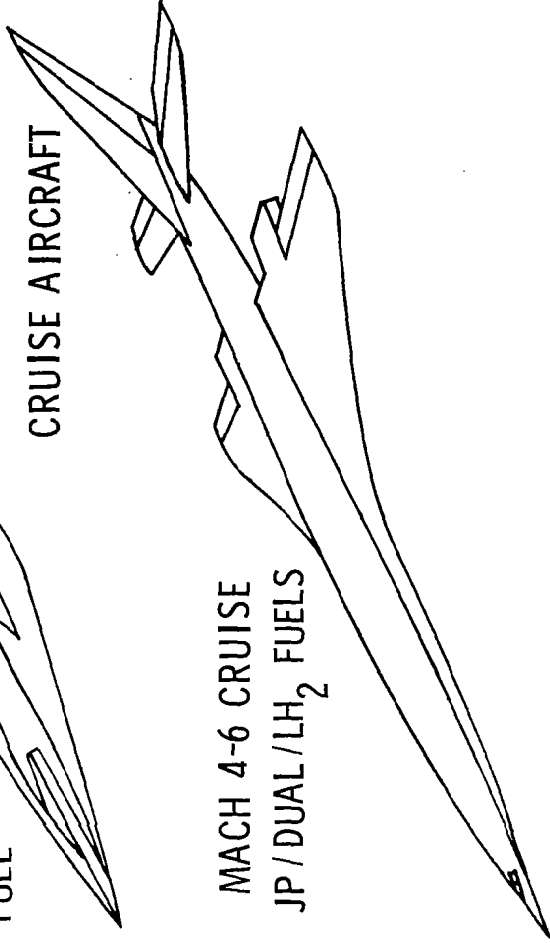

CRUISE AIRCRAFT

MACH 4-6 CRUISE  
JP / DUAL / LH<sub>2</sub> FUELS

Figure 5

## TURBOJET-BOOSTED LAUNCH SYSTEM

(Figure 6)

Figure 6 is a sketch of a turbojet-boosted spacecraft which utilizes near-term aerodynamic and propulsion technology to boost a rocket-powered orbiter to the staging Mach number of about 3. A study of this concept indicated that, for a 29,400 kg (65,000 lbm) payload (east launch), the gross lift-off weight was about 1,200,000 kg (2,700,000 lbm). It required eight to nine turbojet engines per booster (16 to 18 total) each in the 445,000 N (100,000 lbf) sea level thrust class. The concept could potentially provide a totally reusable space launch system with extremely flexible operations. Many of the problems associated with this system are aerodynamic and a wind tunnel test program addressing the major questions will be underway very shortly. The structural questions that one might anticipate with it will probably fall into two major categories: the structural dynamics of the mated vehicles, and the thermal-structural aspects of the orbiter. Without going into great detail on a spacecraft at an aeronautical symposium, I will simply say that this low-wing-loading orbiter concept, which is similar to others studied in the past by NASA, Boeing, and others, utilizes advanced structures technology. It assumes a significant improvement over space shuttle structure/TPS technology with either nickel alloy hot structure or insulated metal heat shields. The booster vehicles could take advantage of either aluminum heat-sink structure or titanium since their structural temperatures would be within the range of today's Mach 3 aircraft.

# TURBOJET-BOOSTED LAUNCH SYSTEM

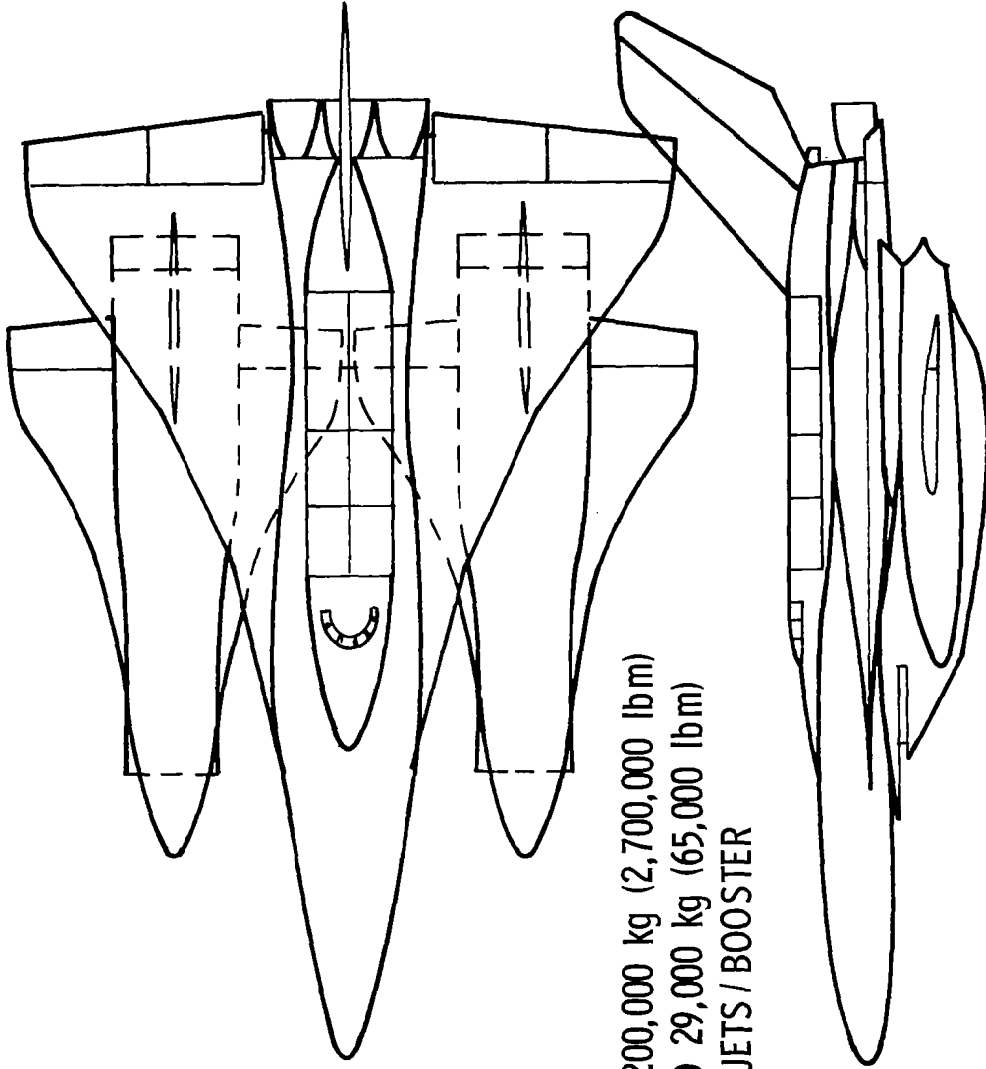

GLOW 1,200,000 kg (2,700,000 lbm)  
PAYLOAD 29,000 kg (65,000 lbm)  
8 TURBOJETS / BOOSTER

Figure 6

(Figure 7)

Compared to the other types of hypersonic vehicles, the hypersonic missile has some unique characteristics and limitations which make it a very different design problem. Missiles fly for short periods in a severe flight environment which combines the problems of high dynamic pressure, high heating rates and high maneuver load factors. They are usually geometrically constrained by the launcher which puts a severe limitation on fuel volume and dictates high-density storable fuel. The need for range brings in the high desirability for airbreathing propulsion and its attendant increment in specific impulse over rocket power. In assessing the technology needs of a hypersonic missile, we had to consider all these factors and others, as shown in Figure 7, and try to determine where it might lead us in the airframe and engine structural design. The airframe requirements which seemed to surface were stiffness, heat-sink capacity, strength, and thermal conductivity, all at minimum weight. This combination of properties led us to consider the use of Lockalloy and beryllium for primary airframe structure, as had been proposed earlier for hypersonic research aircraft. The high-temperature combustor in the ramjet/scramjet engine requires a material with strength at very high temperatures. The development of a structural material which can survive the engine combustor environment without cooling is a key to the success of this class of missile. Some progress in the "hot" combustor materials area will be presented by Mr. Holman of McDonnell-Douglas later in the symposium. The only missile characteristic which is less severe than other hypersonic vehicles is its short service life, since the missile is a one-shot vehicle.

# THE MISSILE DESIGN TASK

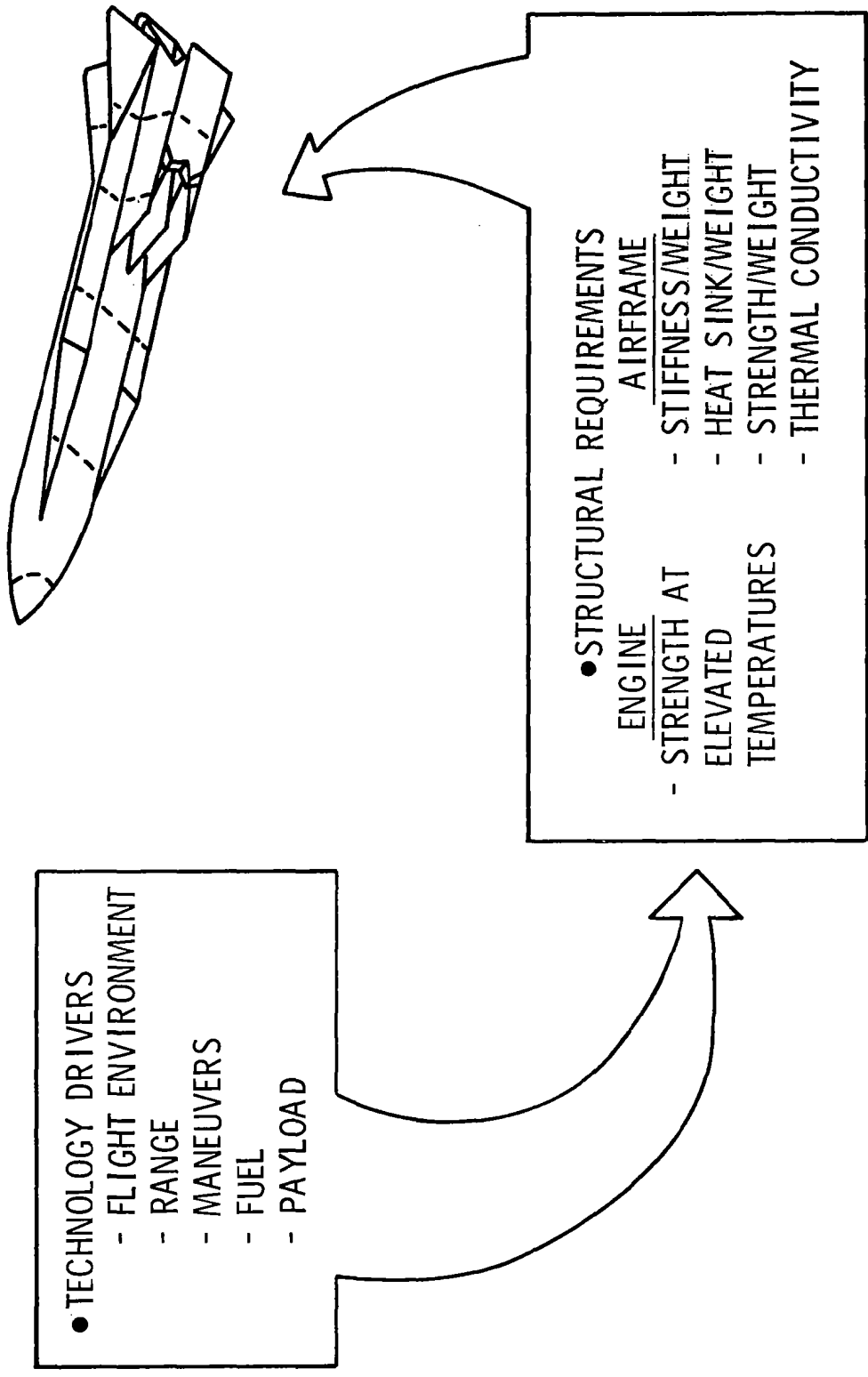

Figure 7

## HYPERSONIC MISSILE STRUCTURAL CONCEPT

(Figure 8)

Adhering to the characteristics shown in the last figure, some of our aerodynamicists have concocted the structural approach illustrated in Figure 8 for a hypersonic missile. This configuration is designed to cruise at a lift/drag ratio of 3.5 at Mach 6 at a 30,500 m (100,000 ft) altitude. The small-span wings are structurally efficient and have relatively low heat loads. The body incorporates an ogive nose shape attached to a constant-cross-section shell structure fuselage with a fineness ratio of 9.5. The flat lower fuselage surface is designed to provide a precompressed inlet flow to the propulsion system. The low wing placement also contributes to the precompression and uniformity of the inlet flow as well as to provide more space for engine installation.

For short flight times, the situation was analogous to the hypersonic research airplane structural problem and led to the examination of heat-sink systems. The main fuselage structure was designed with 0.76 cm (0.3 in.) thick Lockalloy material to provide a heat-sink range of about 370 km (200 n mi.) at Mach 6 (30,500 m (100,000 ft) altitude). The fuselage structure was not allowed to exceed 530 K (494°F) in order to keep the internal insulation requirements manageable. This heat-sink shell can withstand an ultimate boost acceleration of 600g axially at 295 K (70°F) and 100g normal acceleration at 530 K (494°F). The wings are designed with beryllium plate. Beryllium is also used for the control surfaces because of potentially high interference heating rates.



# HYPERSONIC MISSILE STRUCTURAL CONCEPT

HEAT SINK

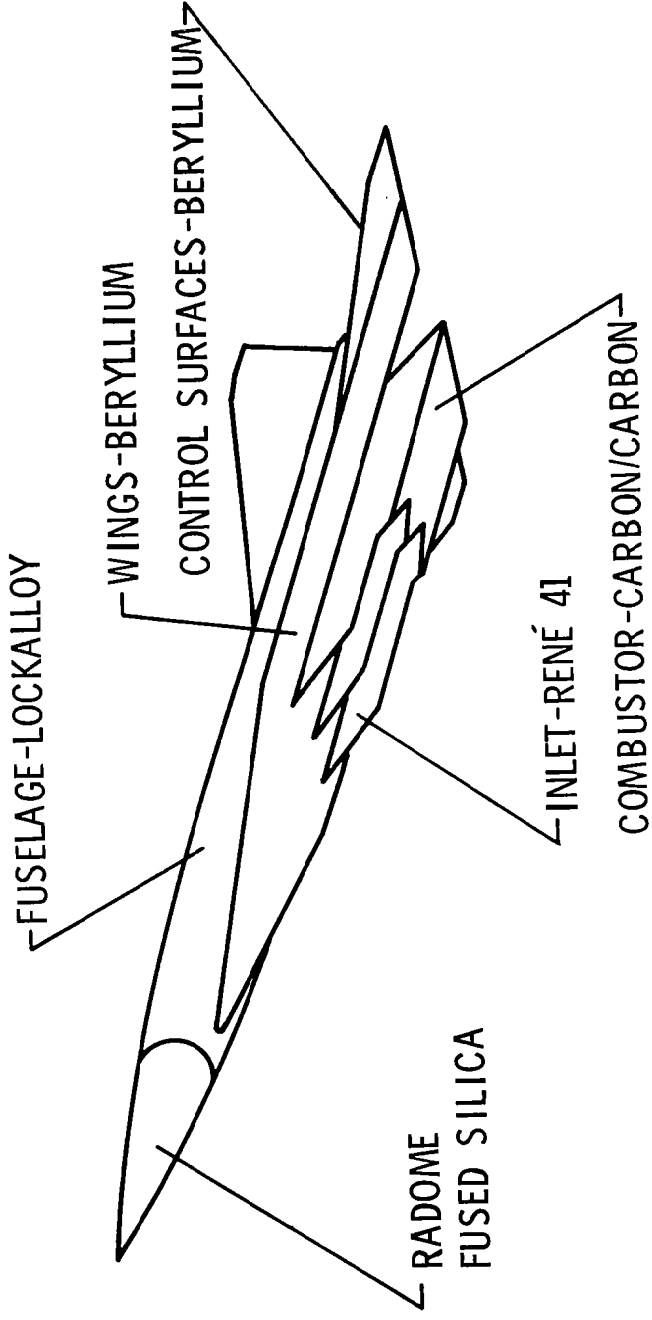

## MISSILE WINDWARD SURFACE TPS

(Figure 9)

For ranges exceeding the Lockalloy fuselage structure heat-sink limit, a radiation TPS was added which kept the underlying structure from exceeding 530 K (494°F). This multiwall radiation shield will be discussed by Mr. Jackson in a later paper. Figure 9 shows some temperature-time histories and the associated Mach 6 ranges for a bare Lockalloy airframe and the same airframe protected by a multiwall TPS as illustrated in the figure. Calculations indicate that a straight heat-sink structure is applicable for short-range defensive or stand-off missiles and a heat sink structure which incorporates metallic TPS might well do the job for long-range cruise missiles.

I would like to point out that our conceptual studies of hypersonic missiles and the related airframe and engine structures has been very limited in scope. We have attempted to derive some basic concepts on which to base our aerodynamics research. Obviously, there are many other ways to build missiles.

# MISSILE WINDWARD SURFACE TPS

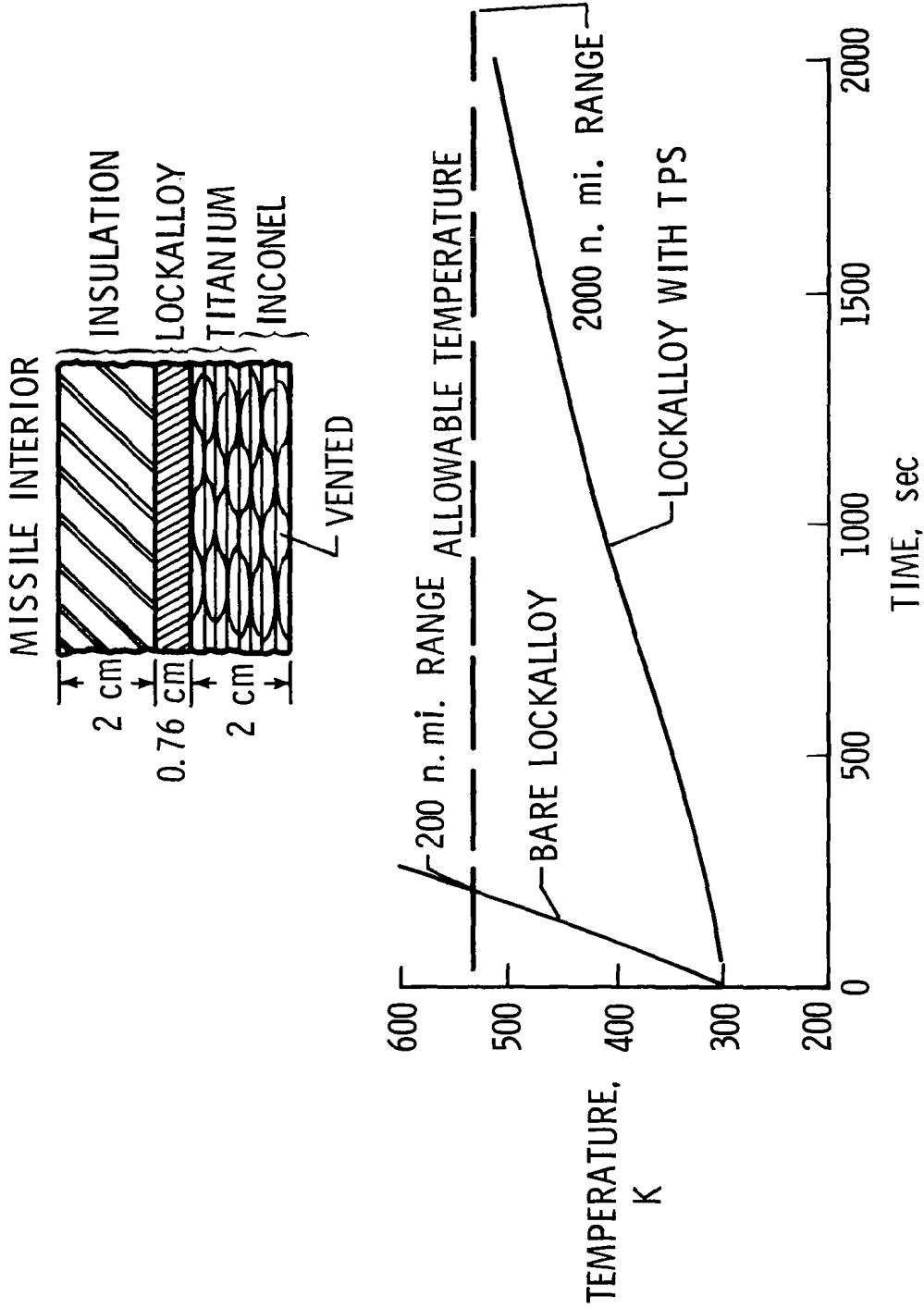

Figure 9

#### EXAMPLE ADVANCED RESEARCH CONFIGURATIONS

(Figure 10)

The need for better aerodynamic efficiency, improved propulsion integration, and lower radar cross-section has given impetus to our current missile aerodynamics research program. We're trying to increase aerodynamic performance without greatly compromising needed compactness while experimenting with engine placement and inlet and nozzle design.

Figure 10 shows two advanced aerodynamic configurations for missiles which we are presently studying. The one on the left is aimed at high volumetric efficiency. The primary objective with the one on the right is high precompression. As you can see, we do not intend to limit our parametric data base development to circular cylinders with a variation of stabilizers.

# EXAMPLE ADVANCED RESEARCH CONFIGURATIONS

UPPER SURFACE ENGINES

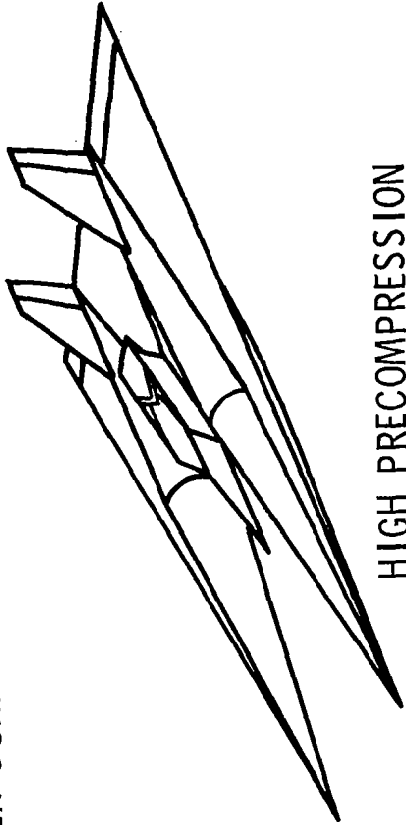

HIGH PRECOMPRESSION

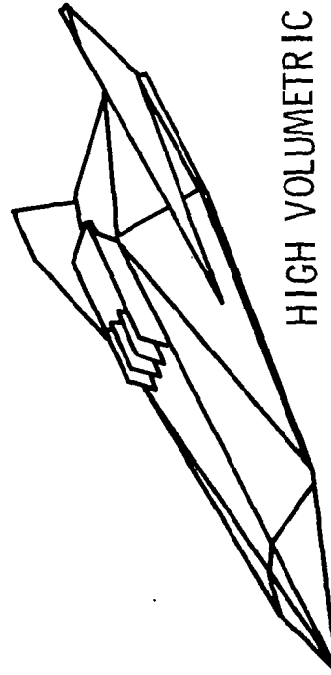

HIGH VOLUMETRIC EFFICIENCY

Figure 10

## HYPERSONIC AIRCRAFT TECHNOLOGY — CURRENT AREAS OF INTEREST

(Figure 11)

In contrast to the hypersonic aircraft studies of the 1960's which tended to emphasize the upper end of the hypersonic speed regime, our current effort is emphasizing the long-neglected technology "gap" between Mach 4 and Mach 6. Also, we are addressing the total problem of how to get a hypersonic aircraft to take off like any other aircraft, accelerate to its cruise speed, perform whatever mission it has, and decelerate and land like any other aircraft. By taking the approach of "walking before we run" we tend to emphasize such menial problems as reducing transonic drag, inventing ways of integrating turbojet and ramjet/scramjet propulsion systems, and at the same time, trying to maintain satisfactory hypersonic performance.

Figure 11 describes the three areas of emphasis in our current aerodynamic research program for cruise aircraft. Each of these areas has its own unique structural requirements defined by fuel selection, material limits, and propulsion modes. By addressing these specific areas in a parametric manner, we hope to provide an aerodynamic data base which spans the entire region. Structurally, of course, this probably implies three separate and extensive research programs.

# HYPersonic AIRCRAFT TECHNOLOGY

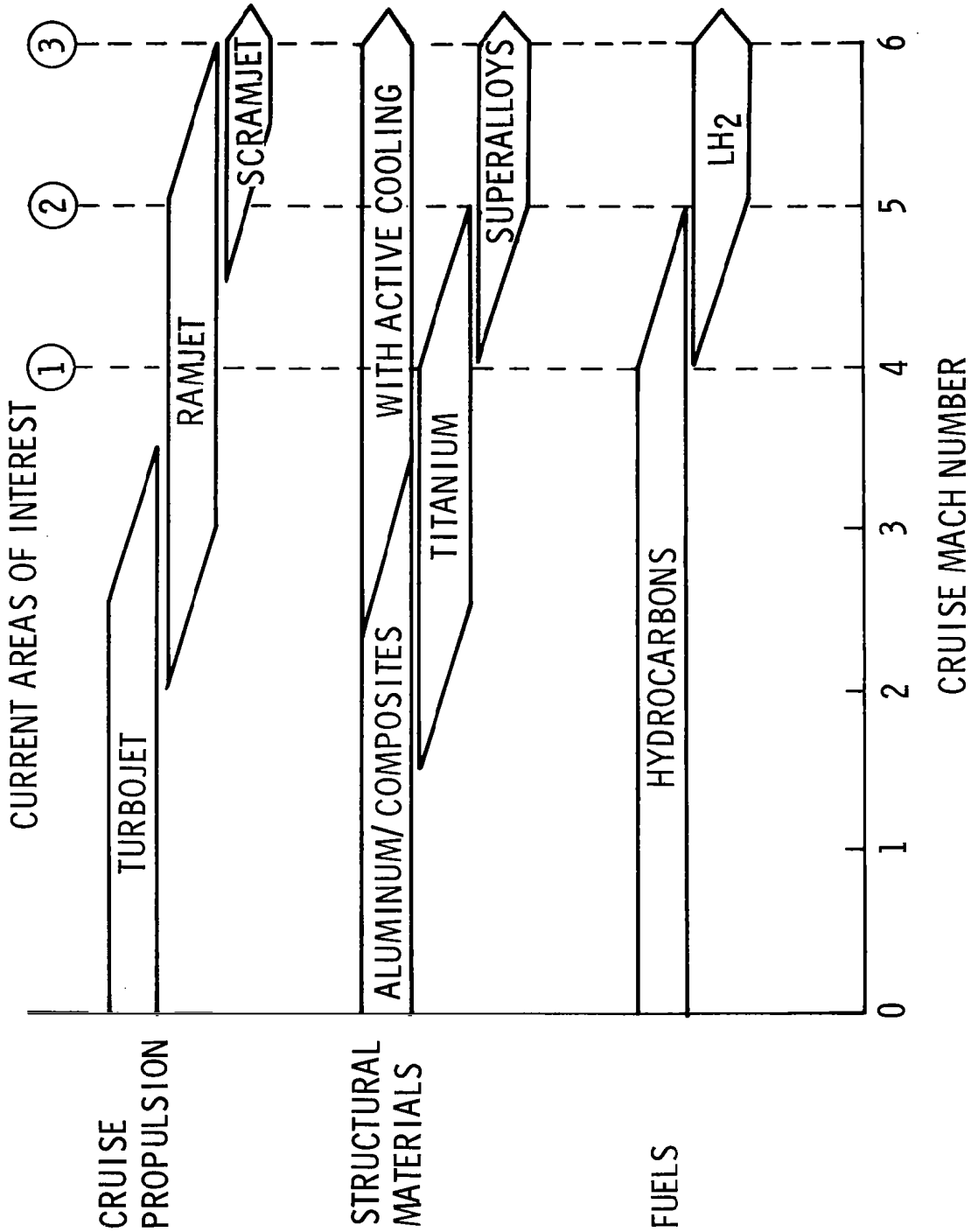

Figure 11

## HYPERSONIC TRANSPORT CONFIGURATION

(Figure 12)

Figure 12 is a hypersonic transport configuration currently being studied for us under contract. The airplane concept is sized for a 200-passenger payload and a range of 9,260 km (5,000 n. mi.) It cruises at Mach 6 and uses all hydrogen fuel with its separate turbojet and dual-mode scramjet engines. The structural design of this aircraft has not been addressed except for attempting to keep the structural mass fraction in a reasonable range. Several structural approaches could be applied to this vehicle including hot structure, metal heat shield TPS, and/or actively-cooled structure.

One of the very difficult aspects of a hypersonic transport airframe structure is the need for long life. This is difficult to get at elevated temperatures, and this fact has led to extensive studies of active structural cooling. Several papers on active cooling will be presented at this symposium.



**HYPERSONIC TRANSPORT CONFIGURATION**  
**LH<sub>2</sub> FUEL, WING-MOUNTED PROPULSION**

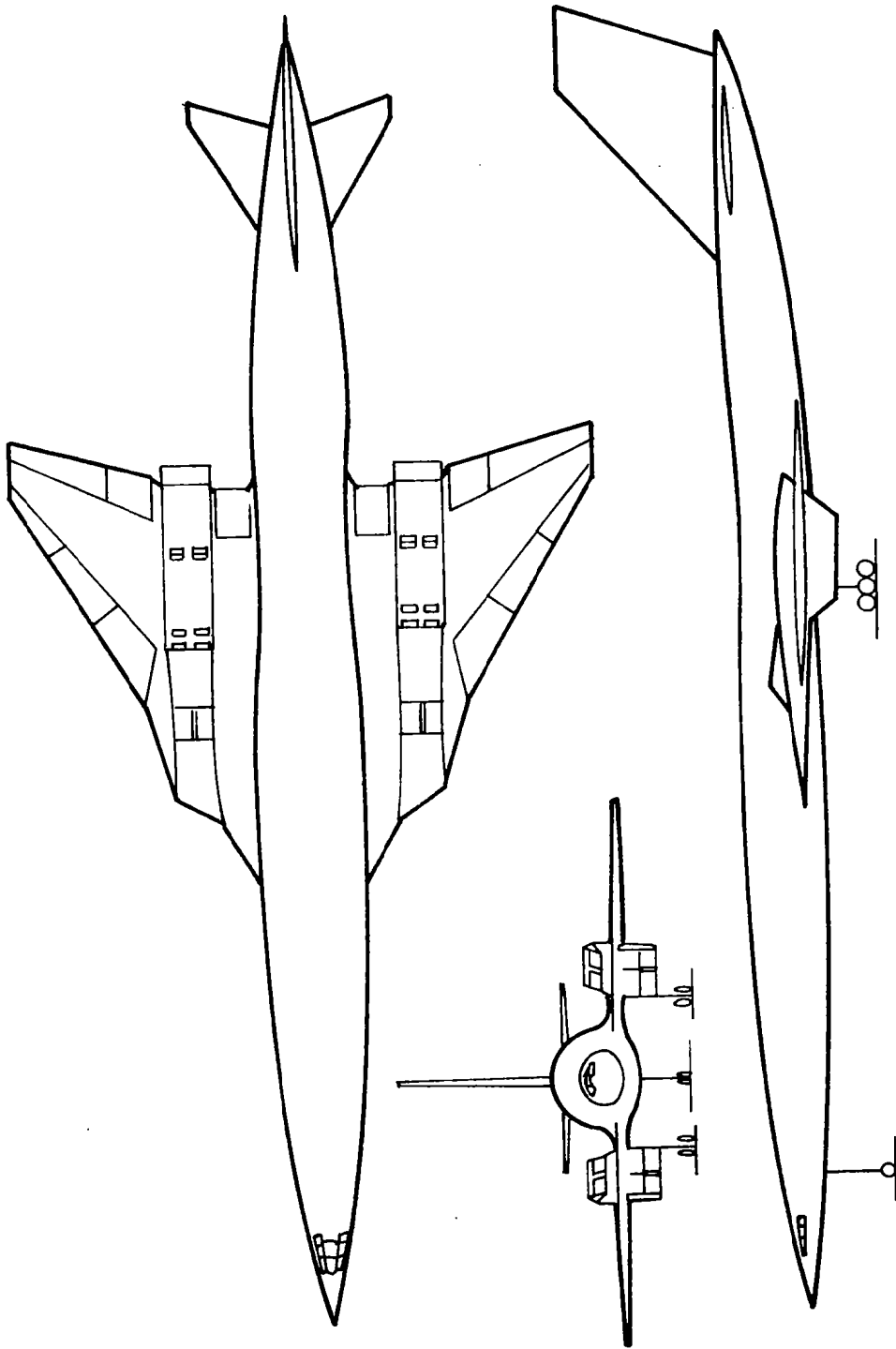

Figure 12

## CONCEPTUAL TURBOJET-SCRAMJET SYSTEM

(Figure 13)

Figure 13 shows a chordwise section view of the wing-mounted turbojet-scamjet propulsion system used with the hypersonic transport of the previous figure. The turbojets are buried in the wing with a retractable inlet. The dual-mode scramjet engines are of the same external arrangement as the Langley fixed-geometry scramjet but they require sufficient variable geometry to allow operation from transonic speed up to the Mach 6 cruise speed. The turbojets operate from take-off to about Mach 3, where they are shut down for the cruise portion of the flight. The general idea of a two-dimensional, variable geometry nozzle is shown to indicate that the turbojet and scramjet nozzles may be compatible in their operation but the design problem will be complex indeed. The inlet temperatures for this Mach 6 arrangement will be in the 1370 K (2000°F) range.

# CONCEPTUAL TURBOJET-SCRAMJET SYSTEM

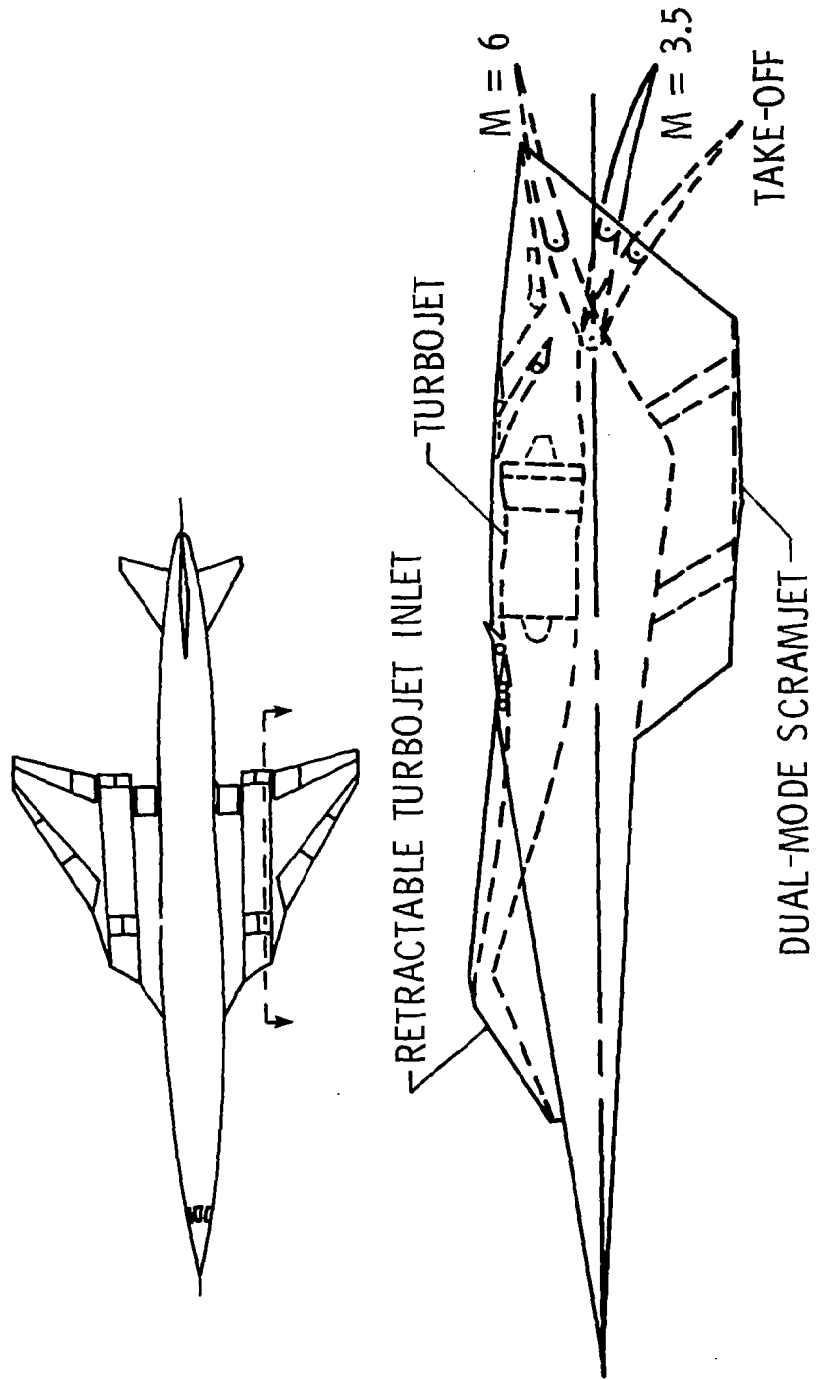

Figure 13

## ADVANCED MACH 5 MILITARY CONFIGURATION

(Figure 14)

Figure 14 is a sketch of an advanced configuration, now in the analysis stage, for application to future military missions which may require extremely high altitude performance and extended ranges in conjunction with reduced radar cross section. This concept used JP fuel for turbojet operation and hydrogen for ramjet cruise. This configuration may undergo extensive modifications by the time it reaches the wind tunnel stage.

There are various types of military applications of hypersonic aircraft which would not require the long life of a transport airframe. Hot structure or metal heat shield TPS could do the job in these cases.

# ADVANCED MACH 5 MILITARY CONFIGURATION

DUAL JP / LH<sub>2</sub> FUEL

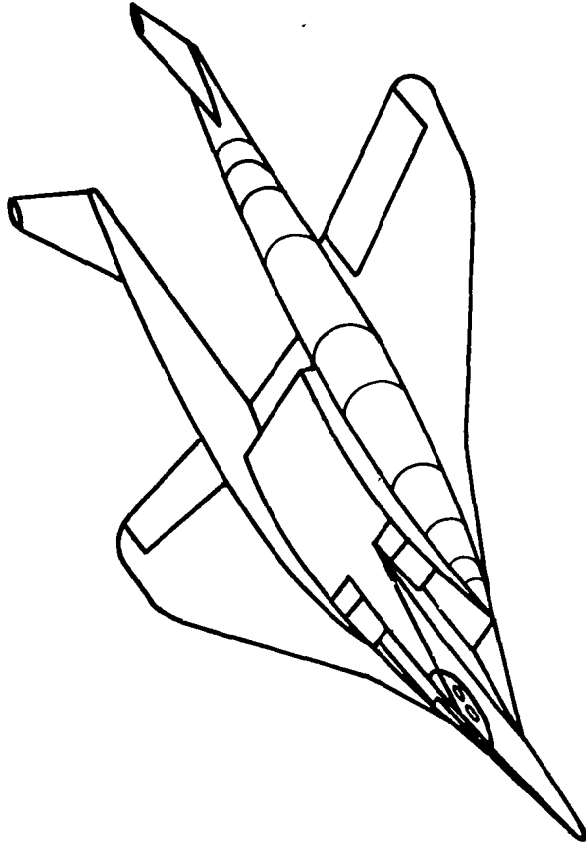

Figure 14

## CONCEPTUAL TURBOJET-RAMJET SYSTEM

(Figure 15)

Figure 15 shows a section view of the centrally-located turbojet-ramjet propulsion system from the military configuration of the previous figure. The inlet is inverted on top of the aircraft in an effort to keep the system out of the line of sight of radar in front of and below the aircraft. The system design allows for turbojet propulsion from take-off to Mach 3 and ramjet propulsion from transonic speed to the Mach 5 cruise. Note that both engines are in operation during the supersonic acceleration. Inlet temperatures in the 1100 K (1500°F) range would be expected on this Mach 5 design. We will be in the process of better defining the environment for such a propulsion system structure during the next year. Again, a two-dimensional variable-geometry nozzle is shown.

# CONCEPTUAL TURBOJET-RAMJET SYSTEM

TURBOJET - MACH 0 - 3.0

RAMJET - MACH 0.8 - 5.0

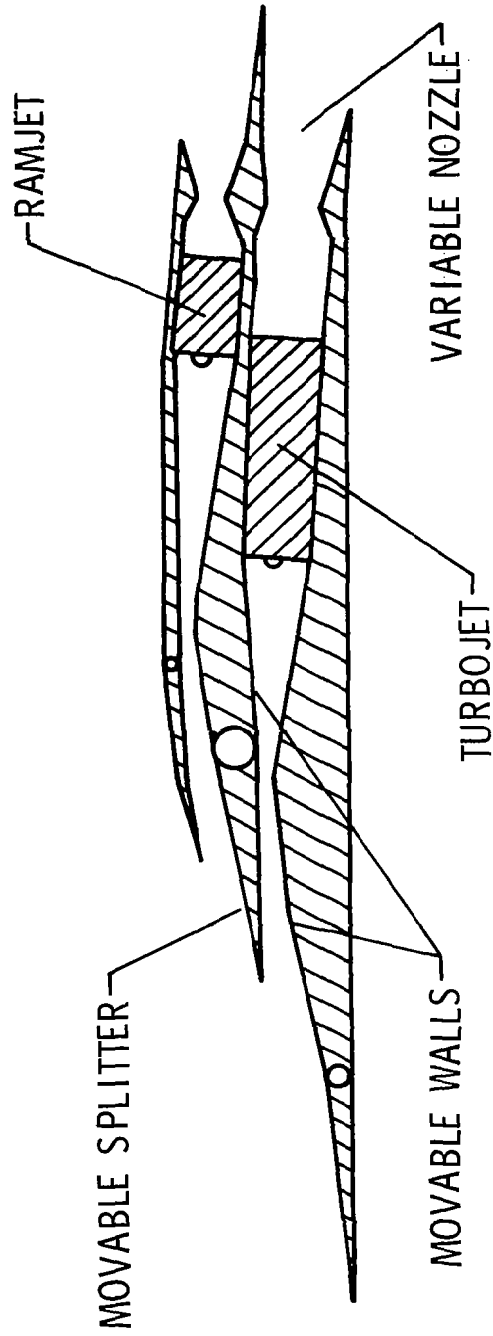

Figure 15

## "COMMON DENOMINATOR" HYPERSONIC STRUCTURES TECHNOLOGY

(Figure 16)

With the current severe limitations on the research and development resources in hypersonics, it is almost ludicrous to carry on and on, identifying endless high-potential areas of research which we will be unable to address. In my opinion, it is also a waste of time to continually seek the ultimate mission panacea toward which we can direct all our resources. We might do well to ask ourselves if there are any common denominators in hypersonic structures technology which stand out among the others as being generally useful. I think there are a few and I've listed them on Figure 16. By addressing areas like these, or portions of them, we tend to advance technology which can be applied to any number of mission vehicles.

The first is the area of propulsion system structures. As you will see later in this symposium, progress is already being made at the upper end of the hypersonic regime with regeneratively-cooled scramjet engine structures. If we can solve the problems of a Mach 4-5 turbojet/ramjet propulsion system, we will also have in hand the means of solving most of the airframe problems for the entire Mach 4-6 speed range.

Another "common denominator" technology is that of liquid hydrogen fuel tank structure, insulation, and thermal protection. I would like to thank our subsonic friends for the work they have recently done in studying the use of liquid hydrogen as aircraft fuel and experimentally evaluating several candidate insulation materials, which you will hear more about later. Although we high-speed people complicate the liquid hydrogen system design problem by going to higher temperatures and requiring thermal protection, many of the LH<sub>2</sub> fuel structural problems are the same.

The development of efficient and practical internally-insulated metal heat shield systems and active cooling would provide needed alternatives to hot structure at the higher Mach numbers. The weight and cost trades among these options may very well dictate that most hypersonic aircraft will employ all three approaches in varying degrees, depending on the mission.

Last, but not least, in the list of "common denominators" is thermo-structural design capability. There are few, if any, established design methods, procedures, and criteria which apply directly to hypersonic aircraft. In addition, designers will have to develop a clearer understanding of thermal stress — its sources and the means of alleviating or minimizing it. So many new concepts become involved in the design of a hypersonic aircraft that current design practices simply are not adequate. The designer will have to be prepared to deal with such complex problems as design optimization where thermal stress, creep, cooling system performance, and thermal protection systems are involved.



These separate components cannot be completely separated by discipline and dealt with individually. They should be considered as integral with the basic airframe structure. Perhaps we're talking about a new "super discipline" of thermo-structural design which might combine several of the current disciplines. This is, of course, a very difficult problem to deal with and it probably will not be dealt with until the various aerospace companies can see some profit in making the required investment. But it does represent a deficiency in our present capability which we should recognize and be prepared to overcome when required.

We in the research and development sector of aerospace should keep in mind that, as the speed of hypersonic aircraft and missiles increases, the disciplines of aerodynamics, aero-heating, propulsion, thermal protection, and structures become more and more closely related and even interdependent. Therefore, the research that is done in these areas needs to be focused on similar objectives with a lot of communication between disciplines. Breakthroughs in one discipline may very well allow breakthroughs in the others, but only if they are communicated in a timely manner.

## **COMMON DENOMINATOR**

### HYPERSONIC STRUCTURES TECHNOLOGY

- PROPULSION SYSTEM STRUCTURES
  - VARIABLE-GEOMETRY COMMON INLETS FOR TJ/RJ
  - VARIABLE-GEOMETRY NOZZLES
  - HIGH-TEMPERATURE AND REGENERATIVELY-COOLED COMBUSTORS
  - FIXED-GEOMETRY SCRAMJET ENGINES
- LIQUID HYDROGEN FUEL SYSTEM - TANK - INSULATION - TPS
- METALLIC HEAT SHIELD TPS
- ACTIVE STRUCTURAL COOLING
- THERMO-STRUCTURAL DESIGN CAPABILITY

Figure 16

## CONCLUDING REMARKS

One of the questions which will undoubtedly be asked toward the end of this symposium is, "Where shall we go with our hypersonic structures effort in the future?" Rather than attempting to answer the question, we from the aerodynamics side of the street have added significantly to your list of options. We do feel, however, that there are several fertile areas for future research which support most of the vehicle concepts discussed here. We in aerodynamics have decided not to wait until the starting gun sounds in the race toward an advanced hypersonic vehicle. We think that by applying our best judgment and setting out on a deliberate, broad research program, we will provide future options to the decision-makers that they wouldn't have otherwise. We know of no reason why the same general line of reasoning doesn't apply in structures.

When the time finally arrives when useful hypersonic vehicles are designed and built, it will be as a result of breakthroughs in hypersonic technology. These breakthroughs, as you know quite well, happen as natural products of a strong research and development program and a sustained high level of activity in the wind tunnels and structures test facilities. With a little cooperation and communication, we may even be able to come up with a hypersonic structural concept that will fly, or an aerodynamic configuration that can be built.