

NASA-ARC 91.5-CM AIRBORNE INFRARED TELESCOPE

By Robert E. Mobley, and Ted M. Brown

NASA Ames Research Center

ABSTRACT

At the 6th Aerospace Mechanism Symposium, September 1971, a paper was presented detailing the planned development of a 91.5 cm aperture telescope to be installed aboard a NASA-Lockheed C-141A aircraft for the performance of infrared astronomy. This airborne observatory is now operational and has exceeded all stability expectations. A unique feature of the telescope is that its entire structure is supported by a 41 cm spherical air bearing which effectively uncouples it from aircraft angular motion, and with inertial stabilization and star tracking, limits tracking errors to less than 1 arc second in most applications. A general description of the system, a summary of its performance, and a detail description of an offset tracking mechanism is presented.

INTRODUCTION

Ground-based observations with an optical telescope are limited by three properties of the terrestrial atmosphere: turbulence, emission and absorption. If a telescope is carried above the troposphere, nearly all turbulence is avoided and both emission and absorption are greatly reduced at many wavelengths in the infrared where water vapor is the source of opacity. To take advantage of high-altitude observations, NASA-ARC has conducted a program of airborne astronomy since 1965, using primarily a CV-990 four engine jet transport and a Lear jet. These aircraft were modified to accept telescopes of up to 30 cm aperture with various stabilizing devices giving long-term line-of-sight stabilities of 10 to 60 arc sec (ref. 1). The intriguing possibility of flying a well-stabilized, large aperture telescope was considered from the beginning of the program and culminated with the 91.5 cm aperture telescope becoming operational in 1974.

The unique feature of the telescope, and the one that, in our opinion, has made the excellent tracking stability possible, was the concept of supporting the telescope on a spherical air bearing and thus effectively uncoupling it from aircraft rotational motions. When this concept was presented at the 6th Aerospace Mechanism Symposium in 1971, it was received (and perhaps rightly so) with some skepticism because of the hostile aircraft environment and the design goal for tracking stability. At that time, the telescope optics were being

figured, equipment components fabricated and the aircraft modified; however, it was still an interesting, but untested concept. Now, after three years of successful operation, we wish to present the airborne infrared telescope as a viable research facility.

SYSTEM DESCRIPTION

Figure 1 shows the telescope installed aboard the StarLifter. The telescope views from an open cavity recessed in the left side of the fuselage forward of the wing and its nominal line of sight is normal to the aircraft longitudinal center line. Movable watertight doors cover the cavity when the system is not in use. For observing, the doors are opened to provide an aperture large enough to preclude vignetting of the telescope over a 4° field of view centered in the orifice. The aperture, or orifice, and the telescope can be moved in-flight over an elevation range of 35° to 75° . Porous spoilers

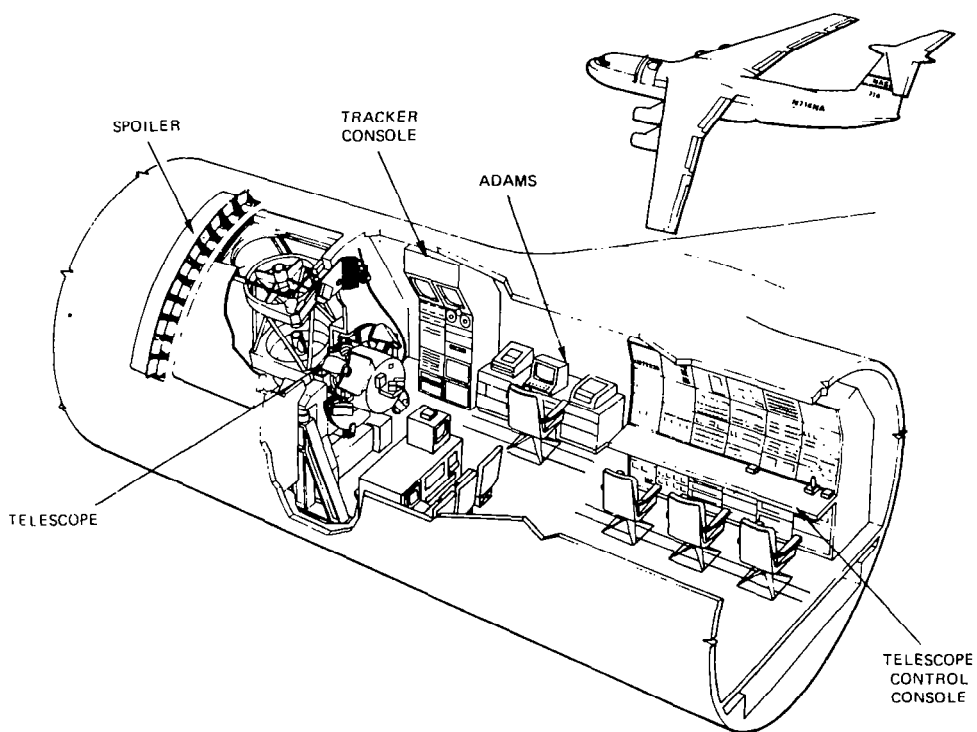

Figure 1 Airborne Observatory

are located in front of the orifice where they control the flow of air across the opening and minimize pressure fluctuations and resonance with the cavity (ref. 2). When the orifice is closed, the spoilers are retracted against the fuselage.

The telescope is a conventional Cassegrain supported in an all-Invar A-frame structure and head ring (fig. 2). The frame and head ring, designed for minimum flexure and low thermal expansion, also support the acquisition and tracking telescopes. The telescope is attached to one side of a 41 cm diameter Invar air bearing that is the single suspension point for the entire telescope system. The air bearing and its matching spherical socket are embedded in the aft pressure bulkhead. A flat mirror located between the primary and secondary mirrors folds the optical axis of the telescope through a hole in the air bearing and on through an equipment mounting flange on the cabin side of the pressure bulkhead.

The primary mirror is a solid CERVIT paraboloid with a 183 cm focal length ($f/2$). It is supported in its cell by axial and lateral pneumatic bellows and locators. Support for the tertiary mirror and light baffle is through the 20 cm core of the primary to the mirror cell.

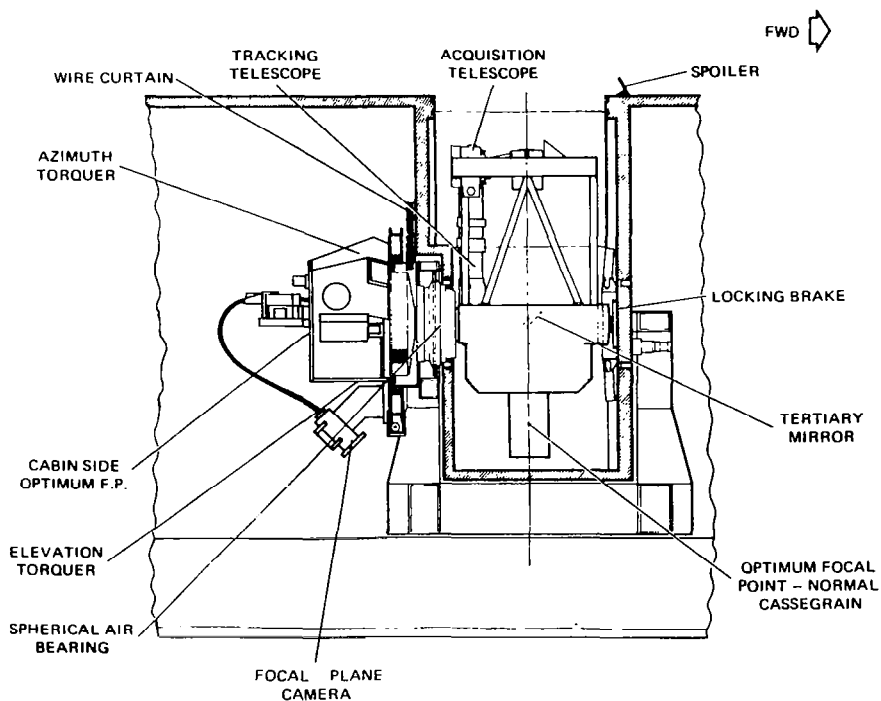

Figure 2 Telescope Installation View Outboard

The secondary mirror, also of solid CERVIT, is a 23 cm diameter hyperboloid figured to yield an overall focal ratio of $f/13.5$ (12.3m) at final focus. The mirror and step-focus drive are held in the head ring by an orthogonal Invar spider. Some types of radiometry and photometry employ a wobbling secondary mirror as an efficient means of space filtering. Accordingly, an alternate secondary assembly is provided that can be oscillated at frequencies up to 40 Hz.

In the folded mode, optimum focus will fall 61 cm from the mounting flange on the cabin side of the air bearing. Total back-focus will be 76 cm. The hole in the flange contains a disk that can be rotated to five positions interposing different pressure-carrying infrared or visible transmitting windows. With one of the pressure windows in the optical path, instruments can be operated in the cabin environment. With the window removed, the detector package can be operated in the cavity environment, provided a pressure vessel (supplied with the telescope) is installed around the detector package or the detector package itself is designed to carry the pressure differential (0.56 atm). A failsafe interlock will prevent rotating the disk across the open-hole position when a pressure differential exists.

A focal plane monitoring system permits either continuous or command monitoring of the focal plane from the console (closed circuit television display).

The cabin-side mounting flange will support up to 182 kg of observational equipment with a center of mass 61 cm from the flange. The experimenters' equipment weight is interchanged with counterweights to maintain balance of the entire telescope (882 kg) on the air bearing. After initial balance, sensors located on each axis will detect any small imbalances that may occur (e.g., cryogenics depletion) and automatically move small counterweights to rebalance the system.

To prevent drag on the air bearing, all electrical, vacuum, and cryogenic lines will be brought from the cavity wall to the mounting flange and telescope as a single bundle or curtain (fig. 2). The curtain will be servo controlled to follow the telescope's motion. Lines to the telescope are passed through the periphery of the hole in the air bearing.

Conventional Cassegrain focus is available with the tertiary mirror removed. Up to 46 kg of equipment can be mounted to the flange behind the primary mirror cell. However, because of space limitations between the back side of the primary mirror and the cavity floor and walls, the total length of the instrument package cannot exceed 50 cm if the entire elevation range is to be used. In addition, instruments mounted at Cassegrain focus must be operated remotely as there can be no direct access to the cavity during flights.

The air bearing support eliminates all rotational motion potentially transmitted from the airplane. All translatory vibrations are attenuated by an active isolation system. The isolators are designed for a cutoff frequency of 3 Hz. They support the telescope at four points, forming a plane that contains the center of gravity of the telescope and thus eliminating cross

coupling of linear vibrations. The telescope structure is designed for a natural frequency of greater than 30 Hz, while the air bearing has a natural frequency of greater than 150 Hz.

Telescope attitude (relative to the aircraft) is sensed by optical digitizing sensors so located as to indicate telescope position in telescope coordinates of azimuth, elevation and line-of-sight.

OPTICAL PERFORMANCE

The telescope is capable of operating at the ambient pressures and temperatures encountered between 15.2 km and sea level. However, the optical quality of the system is optimized for an average altitude and temperature of 13-15 km and 200°K respectively. Exclusive of aircraft boundary-layer effects on seeing, the overall optical quality is such that at least 85 percent of point-source incident radiation at 0.55 microns is contained within a 1 arc-second blur circle. With the 20.3 cm diameter non-oscillating secondary, the area of obscuration is approximately 8 percent; taking into account effects from the spiders, etc., the system is diffraction-limited at about 1 micron.

Currently, a slightly undersized (18.5 cm diameter) aluminized silicon mirror is mounted on a dual solenoid mechanism oscillating at a maximum frequency of 40 Hz. A second generation oscillating system is under development with a capability of square wave operation at speeds faster than 100 Hz. Appropriate baffles and stops minimize scatter and side-lobe response, and the edges of the spiders facing the primary are gold flashed. Development of a family of mirrors is planned for installation as needed on the oscillating secondary mount. Uncoated pure aluminum is deposited on the primary mirror, and alternate secondary and tertiary mirrors with either aluminum or gold coatings are provided. With all aluminum-coated optics, the threshold visual magnitude at optimum focus is $m_v \geq 17$.

TELESCOPE ENVIRONMENT CONTROL

Beside the use of Invar and CERVIT to minimize thermal flexure, the telescope cavity and the instrument pressure dome can be precooled to near the predicted stagnation temperature at the observing altitude. While on the ground, a portable mechanical refrigerator is used to cool the cavity walls and to trap any water vapor inside the cavity. A slight positive pressure is maintained within the closed cavity to avoid ingestion of water vapor or dust from outside. In-flight cooling is provided by an on-board system.

IMAGE STABILIZATION AND TRACKING

The design goal for image stability at the focal plane was 2 arcsec rms for at least a 30 min interval. Drift between the tracking systems and the main focal plane was not to exceed 1 arcsec during this interval. These goals have been met. Four stages of stabilization are required to achieve this accuracy, the first stage being the StarLifter itself. If the autopilot is tuned for a known airspeed, altitude, and payload, excursions in pitch and yaw are held to within $\pm 0.5^\circ$. Even in light turbulence, the autopilot can limit aircraft excursions to $\pm 2^\circ$. The telescope tracking and stabilization systems overcome these latter oscillations.

Inputting a false error signal into the autopilot heading gyro causes the airplane to turn at very slow rates ($0.2^\circ/\text{min}$) and compensate for diurnal motion, thus keeping the observed object centered in the orifice. To view an object at a different azimuth, the airplane is simply turned to a heading that will put the new object athwartship normal to the aircraft or abeam of the telescope.

The air bearing is the second stage of telescope stabilization. Floating on a thin film of high pressure air (the gap between the bearing and its housing will be 1.8 ; air flow will be at 15 scfm at a pressure of 19 atm), the bearing is an almost frictionless support. The air is scavenged to avoid contamination of the cavity. Moreover, the bearing's spherical cross section makes possible three-axis inertial stabilization.

Third-stage stabilization is provided by three gas-bearing gyroscopes and their associated torque motors; each gyro-torquer is tied to one of the telescope's three axes (fig. 2). This system serves as an inertial reference platform for the air bearing. The torque motors can be over-ridden manually to slew the telescope. The segmented dc torque motors are not mechanically coupled between the air bearing and its housing; thus, no static friction is induced into the system. Torque is applied to the telescope by varying the electric field between the "rotor", which is part of the air bearing, and the stator, which is part of the air bearing housing.

The fourth stabilization stage is an image tracking system composed of a 6-inch aperture, f/5 telescope and in the original facility, an image dissector. This system removes gyro drift and other slow random motions, and was originally mounted rigidly to the main telescope and boresighted to its optical axis. Because of the image dissector's modest brightness threshold of $mv=+6$, it was believed necessary to have offset tracking capability, that is, to be able to center faint stars in the main telescope while tracking on the bright ones. Originally, this was accomplished by incorporating a pair of rotating prisms mounted in front of the tracker. It was felt that this method would afford a much better chance of accomplishing precision setting than actually rotating the tracker itself. This rotating prism mechanism worked well, but had to be discarded because of unexpectedly high thermal distortion of the prisms.

Shortly after this, the original image dissector was replaced with a video camera and a new digital tracker was developed in which the camera output was directly used to develop error signals to feed into the gyro control loop. This new tracker system has been used successfully for two years and has demonstrated a brightness threshold of $m_v=+12$, much improved over the old system. Table I is a summary of the performance of the tracker during a test flight when moderate turbulence was experienced. Because of this improvement, the urgency of developing a successful offset tracking capability was reduced, although not eliminated. Invisible infrared sources could not be observed until offset tracking was incorporated. A new mechanism has now been developed which provides offset tracking by rotating the tracker, telescope/camera assembly itself.

TABLE I
TRACKING ACCURACY, DIGITAL TRACKER

	<u>Stellar Target</u>	<u>Visual Magnitude</u>	<u>Error (sec-rms)</u>	
			<u>Azimuth</u>	<u>Elevation</u>
Pleiades	SA0-076228 ⁽¹⁾	3.8	.49	.76
	SA0-076172	4.2	.44	.86
	SA0-076140	4.4	.59	.68
	SA0-076126	5.4	.74	.97
	SA0-076159	5.9	.49	.61
	SA0-076164	6.5	.64	.72
	SA0-076197 ⁽²⁾	6.9	.69	1.40
	SA0-076203 ⁽²⁾	8.6	1.27	1.40
	SA0-076177	9.0	.98	1.80
	Ref. #706 ⁽³⁾	10.1	1.98	2.05

The offset tracking mechanism was to have a range of motion of at least $\pm 1/2$ degree in both azimuth and elevation motions, and thus, assure having a trackable star within range for any point in the sky. It must hold the tracker steady within 1 arc second in a 0.2 g gust flight environment and have adjustment increments of 1 arc second or less, which could be made frequently during tracking maneuvers. Precision setting approaching a few seconds of arc was necessary. It was estimated that, in most cases, positioning the object within approximately 8 seconds of arc would allow an automatic peaking program to make fine offset corrections, which would pull an invisible object into center. Space limitations were very severe, and the operators could not afford an extended shutdown period to allow modifications necessary to relocate the

tracker to a less cramped area. We had to use the existing tracker's mounting surface which is located on the telescope heading close, radially, to the line-of-sight axis. We could not violate the 36-inch diameter aperture cylindrical space, a difficult feat, because the tracker's existing mounting flange was already up against it. Also, we wished to make use of the old stepping motors (2000 steps/sec) and encoders (10,000 counts/sec) from the rotating prism mechanism, to drive the new mechanism.

Figure 3 shows the mechanism. It is ring shaped and is sandwiched between the tracker's mounting flange and the bottom side of the main telescope's heading. A stack of circular leaf springs serve as a flexure connecting the tracker to the heading. The springs are mounted to the heading at three nearly equally spaced points, around the circle, while the tracker is connected to the springs at points between these. The springs act as a very rigid constraint for three degrees of freedom of motion of the tracker (two lateral translations and axial rotation), but allow flexibility in three others (axial translation, and two lateral rotations). Three screw jacks constrain and adjust the tracker for these flexible degrees of freedom. The jacks, mounted rigidly to the heading through stout shackles and a base ring, bear against the tracker near the points of connection to the springs. They always operate within a range such that the springs produce enough load to the jacks to prevent backlash and separation in a 0.2 g gust environment.

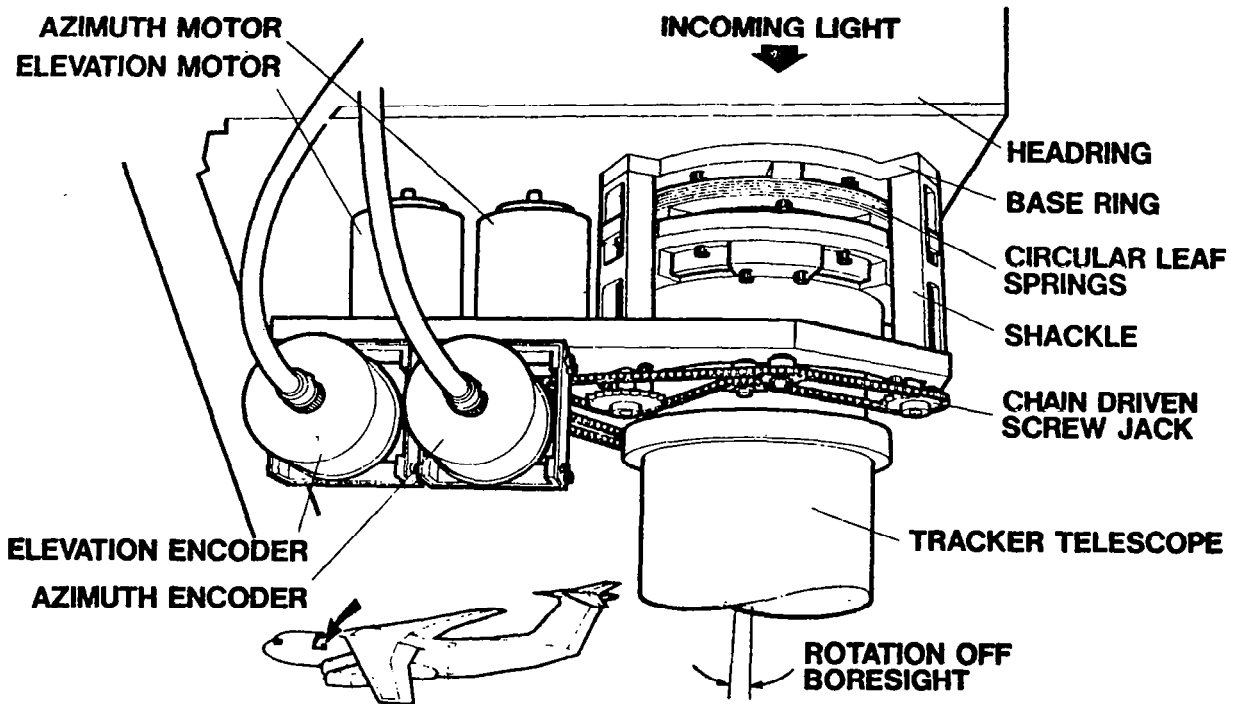

Figure 3 Tracker Offset Mechanism

The jacks are actuated by a pair of stepping motors and a system of chain drive. The elevation rotation is accomplished by driving just one jack, while azimuth rotation requires driving the other two jacks in opposite directions in the same chain loop. This simple combination of jacking motions is possible because there is no requirement to locate the axes of rotation precisely other than to orient them accurately. Encoders sense the jacks' positions.

The mechanism has demonstrated extreme steadiness, no observed degradation from the previous rigid mounting. The chain drive and encoder gearing allow incremental motions of 1/4 arc second. The initial setting precision has been disappointing in that after the mechanism was moved through a dozen offset maneuvers, an RMS setting error of approximately 30 arc seconds occurred. Close examination of the results indicated that a disproportionate amount of the error was in offset direction rather in offset distance. Such a tendency cannot be explained by mechanism imprecision, but only by errors in calculating rotation of the stars relative to the telescope's line of sight (L.O.S.) rotation. Further examination brought to light that, indeed, telescope L.O.S. rotation was not being accurately sensed and used properly by the on-board computer to make the offset direction calculation. The problem is that the telescope L.O.S. has as its only reference the aircraft, which in normal flight is experiencing continual pitch variations (which translate into telescope L.O.S. rotation). There presently exists a control system which can hold the L.O.S. to the aircraft pitch, but the computer makes rotation calculations only every 10 seconds, in which time the aircraft pitch can change markedly. (Parameters used by the computer to calculate offset direction include the star's coordinates, sidereal time, aircraft's longitude and latitude, and aircraft pitch.) What is required is either increasing the frequency of offset direction calculations to every one or two seconds (which would overtax the present on-board computer capacity) or allow the L.O.S. to inertially stabilize over relatively long periods (approximately one minute) and make occasional gross correction when the telescope drifts away from the center of the viewing orifice. This scheme requires a new control system to make this occasional step motion. One of these methods must be used to handle the L.O.S. rotation, and as of this writing, a decision has not been made as to which is most practical.

If one ignores the direction errors in our first tests and only considers offset distance errors, the RMS error was approximately 6 arc seconds, which must all be attributed to mechanism setting imprecision. Two problems have been found which we believe will account for most of this error. We used a miniature roller chain of 0.1475-inch pitch, which turned out to be much more flexible in tension than we had originally estimated (more than ten times). This increased flexibility allows a backlash effect and an effective change in scale factor for different offset position and direction. Scale factor changes apparently occur because the jacking screw torque, and therefore, chain tension varies as the offset positions change. We are presently correcting this problem by replacing the miniature pitch chain with Standard No. 25 roller chains, which is approximately 5 times as stiff. The other problem involved motor shaft bending which primarily resulted in inaccurate encoder readings because of relative motion of the worm and wheel in the worm gear drive. We

are correcting this by mounting outboard bearings to the motor shafts.

Indications are that the future success of the offset tracking mechanism will be more dependent on solving the Line of Sight rotation problem than any setting imprecision of the mechanism itself. While the telescope elevation and azimuth rotation are being stabilized to 1 arc second, all we require in the L.O.S. is knowledge of its position to within approximately a tenth of a degree (or 360 arc seconds).

We believe this can be accomplished. The mechanism itself is proving itself well suited for its application. Over long periods of non-use, it behaves the same as a rigid mounting; the screw jacks are sufficiently loaded that the static friction at the threads allows no motion whatsoever. Its main drawback is in the drive system; considerable torque is required to turn the screw jacks and as a result, components in the drive system experience sufficient elastic deflections to introduce setting errors. We believe the stiffer chain and the outboard bearings on the motor shafts will go a long way to correct this problem.

CONCLUDING REMARKS

The Airborne Observatory has proven to be a very useful facility. It combines a number of unique mechanisms in an unusual application, the most interesting being the use of an air bearing in such a severe environment. It has been most remarkable in that while it performs with such high precision, it remains a very practical and easy to use tool. Rather than being a delicate and fragile device subject to easy failure and malfunction, it is a very sturdy and practical workhorse, capable of undergoing continuous changes to accommodate new experiments, while, at the same time, keeping a busy schedule of two or three flights a week.

REFERENCES

1. Bader, M.; and C. B. Wagoner: NASA Program of Airborne Optical Observations. Appl. Opt. 9.265 (1970).
2. Buell, D. A.: An Experimental Investigation of the Airflow Over a Cavity with Antiresonance Devices. NASA TN D-6205, 1971.
3. Mobley, R. E.; and Cameron, R. N.: NASA-ARC 36-inch Airborne Infrared Telescope, 6th Aerospace Mechanism Symposium, September 9 - 10, 1971.
4. Walter V. Sterling, Inc: Digital Tracker Flight Test Results, WVS Report No. 3-75-06, March 14, 1975.



MR. BOWDEN W. WARD, JR., presents the Dr. George Herzl Award for the best paper to
Michael J. Ospring and Ronald E. Mancini