

THE DESIGN AND TESTING OF A MEMORY
METAL ACTUATED BOOM RELEASE MECHANISM

by

D.G. Powley : British Aircraft Corporation Ltd.
G.B. Brook : Fulmer Research Institute Ltd.

ABSTRACT

Shape memory metals are used commercially in a number of gripping mechanisms such as tube connectors. A boom latch and release mechanism has been designed, manufactured and tested, based on a specification for the ISEE-B satellite mechanism in order to demonstrate and gain experience of shape memory alloys to do useful work by operating a useful mechanism.

From experimental results obtained, it is now possible to calculate the energy available and the operating torques which can be achieved from a torsional shape memory element in terms of the reversible strain induced by prior working. Some guidelines to be followed when designing mechanisms actuated by shape memory elements are included.

INTRODUCTION

Shape memory metals can be deformed into a new shape below a critical transformation temperature. On heating above this temperature the shape changes back to the original shape. If this change of shape on reheating is restrained, the shape memory alloy can be used to generate a force capable of doing work or of gripping a rigid body. The work done can provide the primary energy in a mechanism or activate the released energy stored in another way e.g. by a spring.

This mechanism is designed to enable three hinge booms to be latched for launch, and deployed by the spinning satellite once it is in orbit (Figure I). It utilizes the recovery of a nickel-titanium alloy torsion element to effect the high speed release of two spring loaded ball bolts. These release two of the booms, the mechanism itself remaining attached to the third boom when deployed.

In order to understand the reasons for the design of the mechanism, it is necessary to look at some of the properties of memory metals.

PHYSICAL PROPERTIES OF MEMORY METALS

The specific alloy used for this application is a solid solution based on the intermetallic compound TiNi, using a composition exhibiting a martensitic transformation close to ambient temperature.

In its high temperature state, TiNi demonstrates high strength and ductility, impact resistance and high creep and fatigue resistance. As the temperature is lowered through the Ms temperature (that at which the martensitic transformation begins on cooling with zero stress) a stress induced plasticity can be obtained at progressively lower stresses until at the Ms temperature, stresses as low as 27 MNm^{-2} (4000 p.s.i.) are sufficient to cause deformation (Figure 2). On release of the stress, at temperatures above the Ms temperature, all or substantially all of the stress induced strain is recovered in an apparently elastic manner.

On deformation below the martensitic transformation temperature, Ms, only part of the stress induced strain is recovered on unloading (Figure 3, upper region). However, if the material is heated above the temperature at which the reverse transformation takes place, (As temperature) the high temperature structure is progressively reformed, the apparently plastic strain is reversed and the original shape restored (Figure 3, lower region). Thus the shape memory material can be put into the required shape at a high temperature and retained in such a state during cooling to a lower temperature, (below the Ms temperature in the absence of an applied stress). It can then be deformed to a new shape at the low temperature. On reheating above the As temperature, the material recovers to its original shape, or if the change in shape is restrained, will exert a force up to the yield stress of the material at that temperature. If the alloy is then cooled again it will normally retain that shape unless the restoration of the original shape is not complete, when some reversion to the deformed shape will occur. If a stress is applied during cooling, the shape will change so as to relieve the applied stress.

Two modes of use are thus possible:-

- a) The material is deformed and is normally in a low temperature (below As) state. On heating above the As temperature the original shape is recovered and this activates the mechanism.
- b) The material restrains a high stress, and is normally in a high temperature (above Ms) state. On cooling to below the Ms temperature, the material progressively deforms under the applied stress and allows the mechanism to operate.

In the heating mode (a), there is a disadvantage that the yield stress of the material in its normal (low) temperature state is low, and thus cannot be used to react any significant load. Whilst this situation does not occur in the cooling mode (b), the obvious difficulties of cooling the material in a spacecraft in order to activate the release mechanism lead to the selection of the heating mode for the design.

BOOM RELEASE MECHANISM DESIGN

Design Requirements

The main requirements for the mechanism are:-

- (i) it must release within 30 seconds of the release command being given;
- (ii) the booms must be released within 20 milliseconds of each other (necessary to maintain spin stability);
- (iii) the power available for heating is 15 Watts from a 28 volt power source;
- (iv) the latch must withstand thermal cycling in the range -30°C to $+30^{\circ}\text{C}$ without loss of ability to operate on command;
- (v) the booms must be latched with a pre-load of at least 800 N (180 lbs).

Design Details

The constraints of power and release time fix the maximum mass of material that may be used at 3.2 grams (assuming a heating efficiency of 50 per cent) i.e. just under 0.5 cc. In its low temperature state, this amount of material is too weak to operate the mechanism directly, and is used as a trigger to release two spring operated ball bolts (Figure 4). The spools in the bolts are joined to a crank by a connecting rod (Figure 5). In the latched position this crank tries to turn counter-clockwise and is prevented from doing so by a fixed stop, so that no load is transmitted to the element. The bolts are pre-loaded by tightening the nuts and thus pulling the fixtures attached to the two booms firmly onto the conical seatings.

The NiTi memory metal element takes the form of a short torsion cylinder, (Figure 6) having square ends and a cartridge heater located in the central bore. This form was chosen to minimise the amount of redundant material and enables efficient utilisation of heat from the cartridge heater located in the cavity. The ends were made from TiNi as a matter of convenience but could be any low conductivity material. The element is twisted by 20° after immersion in liquid nitrogen in a simple jig, and retains this shape at all temperatures below about 35°C (the A_s temperature). One end of the element fits in a square hole in the housing (Figure 5), and the other fits into a small drive dog, which just contacts one of the pivot pins in the crank. The housing has slotted fixing holes to allow it to be rotated until the drive dog comes into contact with the pivot pin, whereupon the housing is fixed.

When the element is heated the strain is gradually recovered and the element rotates the drive dog by up to 20° . The slow recovery rotates the crank up to, and over, the top dead centre position, when the crank rotates rapidly clockwise under the influence of the spring loaded spools in the ball bolts.

Since both spools are connected to the common crank both release rapidly and simultaneously. Because the drive dog only pushes against the pivot pin, the crank is not restrained in any way by the remaining slow recovery of the element and can rotate clockwise very rapidly. At the end of their travel the spools strike the cap nuts at the inner end of the ball bolts, the balls drop inwards, and the booms are released.

The spools are a Ti6Al4V alloy, and are lubricated where the balls contact with a buffed-on film of molybdenum disulphide. All the bushes in the connecting rods and trigger mechanism are of a proprietary dry-lubricated type.

TEST RESULTS

Tests on TiNi Alloy

Extensive testing was carried out to determine the properties of the NiTi alloy in tension, compression and torsion. The performance of the torsion element was preferred and an element was manufactured and tested. The performance characteristics are recorded in Table 1. It should be noted that the strain occurs largely in the circular cross-section part of the element and that the deformation of the square ends is minimal. The "active volume" of the material is therefore less than the overall volume of the element and amounts to 0.5 cc (3.2 g).

Tests on Release Mechanism

Tests were carried out on the mechanism to assess its performance under nominal conditions, and also to investigate the effect of altering parameters such as bolt pre-load, angular movement of the crank to achieve top dead centre position (over-centre angle) etc.

The main performance characteristics measured were the time taken for deployment to occur after the command was given, and the temperature attained by the element at release (this was corrected for fluctuations in ambient temperature from a knowledge of the temperature rise characteristics of the element). The longer the time taken to operate and the higher the temperature, the more stress and/or angular recovery is being developed by the element. The results are summarised in Table 2.

Two failure modes were anticipated:-

- (i) The pre-load on the bolts may be too high (due to errors in torque tightening), pushing the balls onto the spool so hard as to prevent it withdrawing, even though the crank has rotated over-centre. However, pre-loads of 5000 N (3 times the nominal value) did not prevent operation. Calculations showed that the friction coefficient between the steel balls and the spool was about 0.13. The molybdenum disulphide coating lasted for about 40 operations before the spools failed to release, necessitating re-application of the molybdenum sulphide.

- (ii) The over-centre angle could be increased to such a degree as to prevent the trigger mechanism from operating. A higher torque and a larger angular movement are necessary to overcome this defect. Testing showed that the element had the capability to release the mechanism with an over-centre angle of 13° (normal value 8°). As expected, both time-to-release and temperature at release were increased as more recovery and higher torque is necessary.

DESIGN GUIDELINES

Where input power is limited, as is often the case with satellite mechanisms, only small volumes of material may be used. Because of the correspondingly small amount of energy available, the material may best be used to trigger the release of other stored energy, as in this design.

The low yield stress when in the low temperature (quiescent) state points to the selection of designs in which the memory metal is unloaded.

Whilst other forms of the material are useful in specific applications, torsion elements are particularly useful in offering a significant amount of movement with a moderate force, while maintaining a compact form easily heated and integrated into a mechanism.

Although pyrotechnic devices may perform some functions as well if not better, there may be applications in which memory metals offer considerable advantages. For instance, in a satellite operating in an electrically noisy environment, a pyrotechnic device may be prematurely triggered by spurious command signals, whereas a memory metal device needs a 'fire' command of at least several seconds, so making it much more resistant to electrical interference.

CONCLUSIONS

High speed operation can be obtained by a suitable design, even though the shape recovery process itself is relatively slow. Memory metals can be used to meet real engineering requirements, as an alternative to electric motors, pyrotechnic or electric actuators, which are often larger and heavier. Sufficient data now exists to enable a designer to select a NiTi alloy for a mechanism with a high degree of confidence that it will perform as predicted.

REFERENCES

Brook, G.B. and Powley, D.G., 'Development of a Memory Metal Boom Latch and Release Mechanism'. Final Report R662/4/Jan 1977, held at the European Space Technology Centre, Noordwijk, Netherlands.

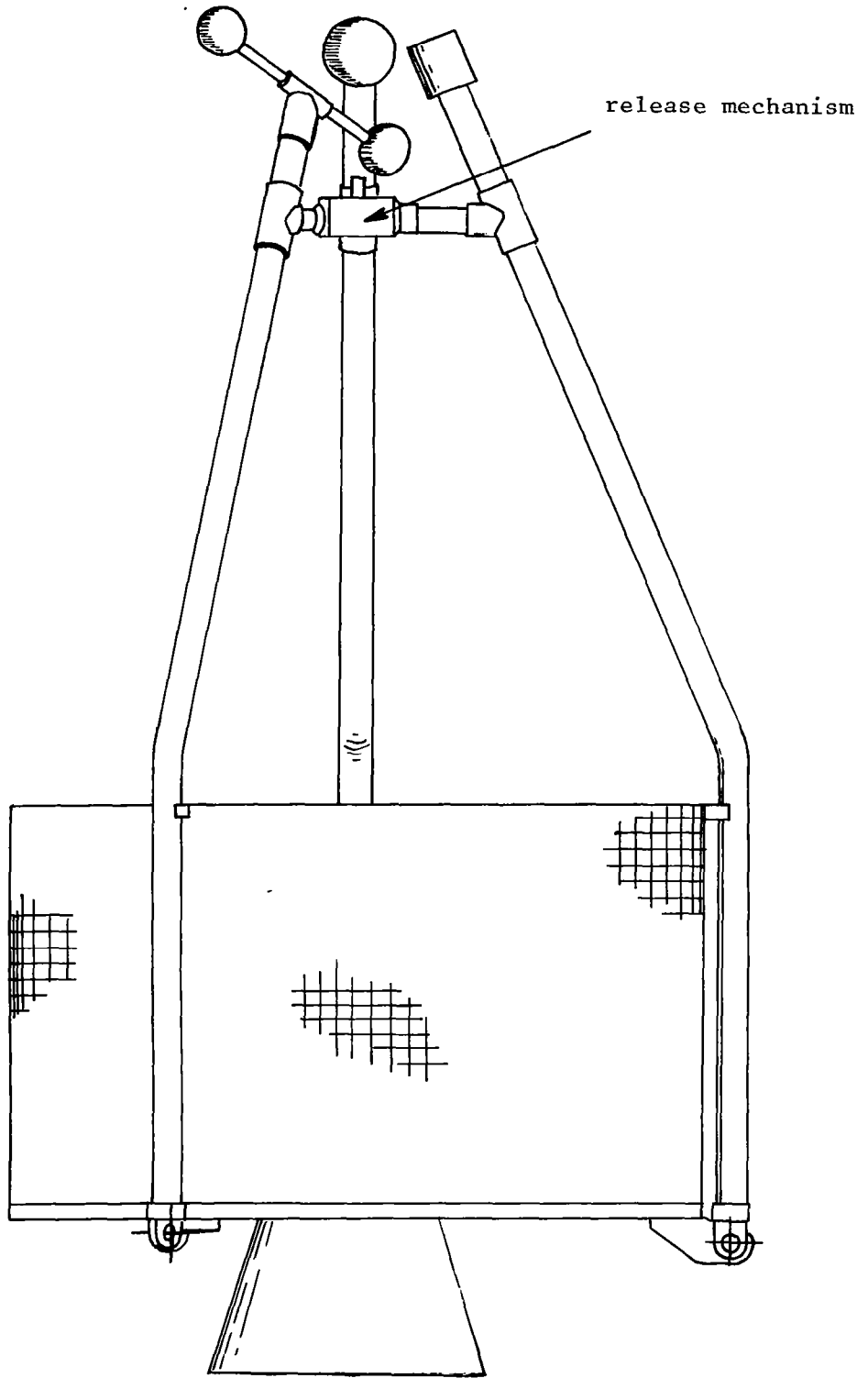

HINGE BOOMS IN LATCHED CONFIGURATION

Fig. 1

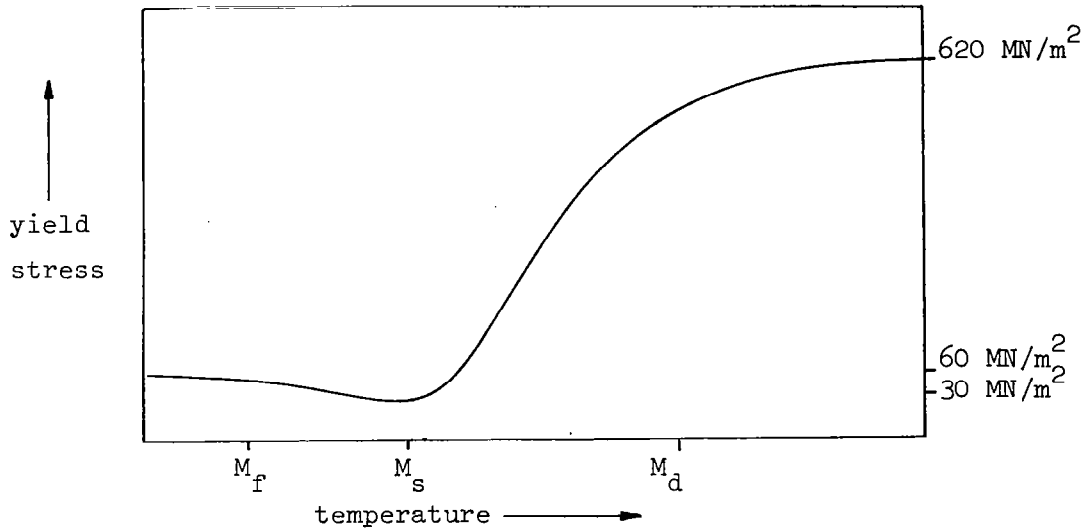

Relationship between yield stress and temperature for a typical shape memory alloy. M_d and M_s temperatures are the maximum temperatures for the start of the transformation under stress and at zero stress respectively. M_f is the temperature at which the transformation ends under zero stress.

Fig.2

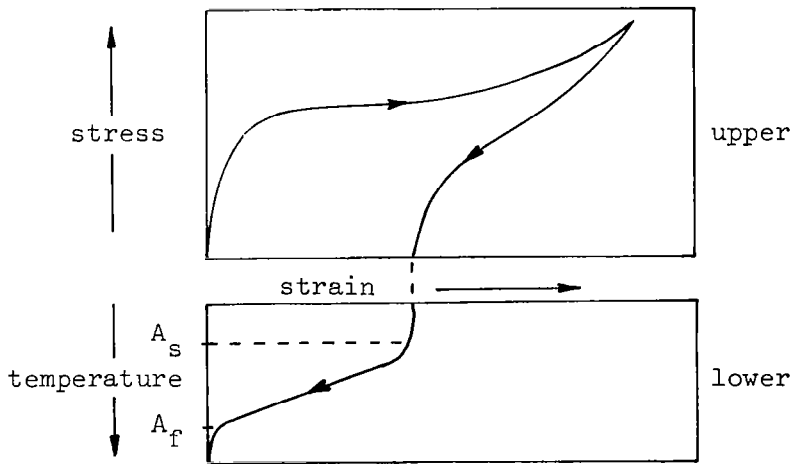

(upper) Stress-strain curve of memory metal at constant temperature below M_s temperature.

(lower) Temperature-strain curve of deformed shape memory metal at zero stress on heating to above A_f temperature.

Fig.3

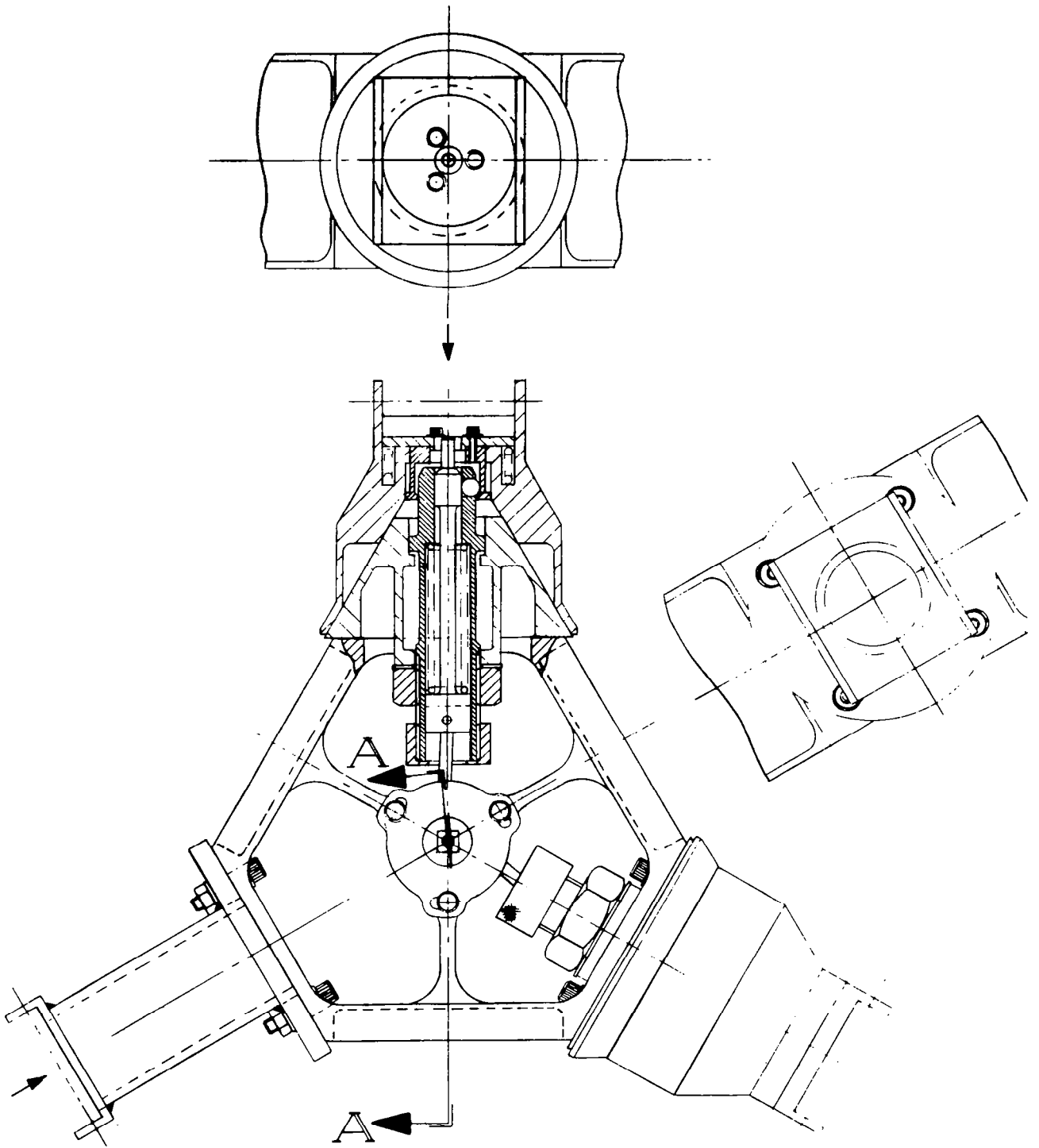

Scale: | 1 inch |

RELEASE MECHANISM

Fig. 4

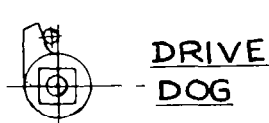
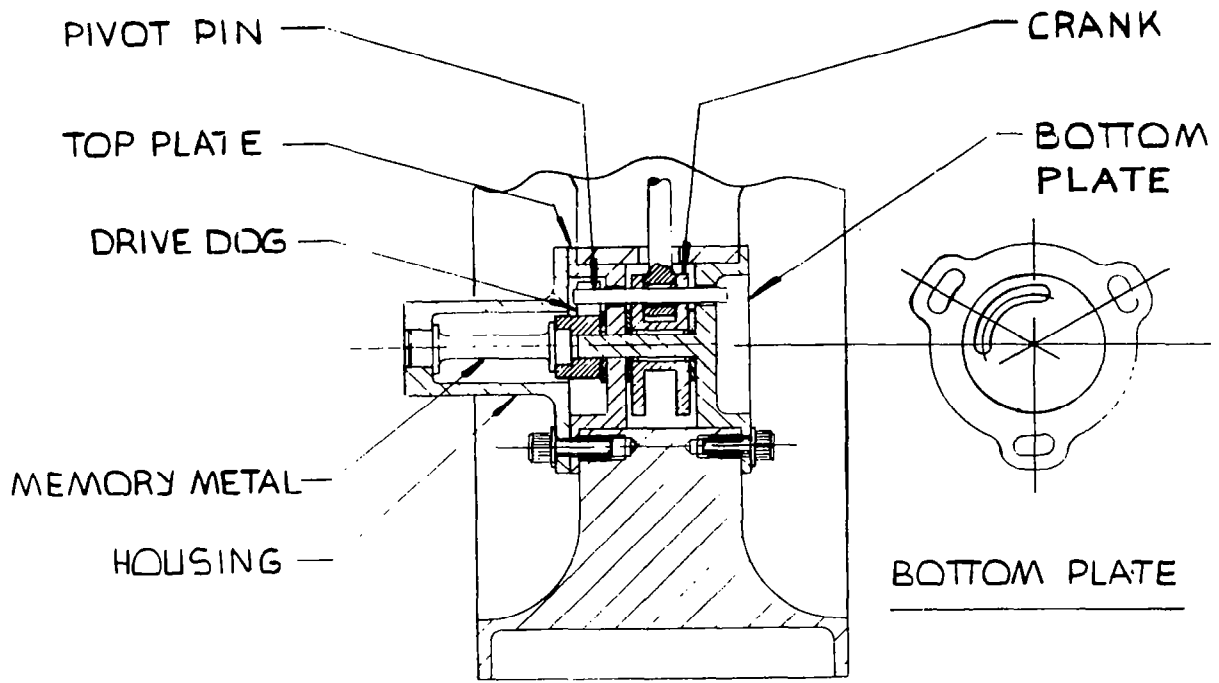

SECTION A-A

TRIGGER MECHANISM DETAILS

Fig.5

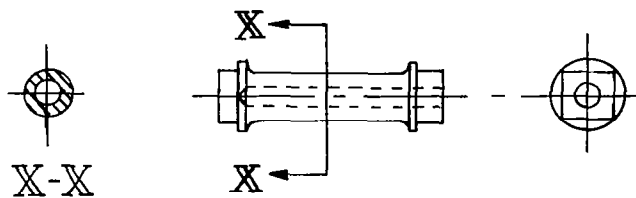

Circular cross-section:-
 Outside dia. 7.0mm
 Bore dia. 3.5mm
 Length 22.0mm

SHAPE MEMORY METAL TORQUE ELEMENT DIMENSIONS

Fig.6

Angular rotation	20° (0.35 rads.)
Torque available	16 Nm (11.8 ft.lbf.)
Energy available	6.78 Joules
Surface shear strain	0.097 rads.
Start of shape recovery	35°C
50% recovery	47°C
Specific energy	13.7 x 10 ⁻³ J.mm ⁻³

TABLE 1
CHARACTERISTICS OF THE TORQUE ELEMENT

Test description	Release time (secs)		Release temp. °C	
	Mean	Standard deviation (No. tests)	Mean	Standard deviation (No. tests)
Nominal parameters	15.6	1.63 (8)	48.0	3.00 (3)
13° over-centre angle	24.9	2.28 (5)	62.4	3.13 (5)
5000 N bolt preload	16.0	1.16 (4)	46.0	2.16 (4)
Ambient temp. -30°C	28.0	1.58 (5)	42.8	3.11 (5)
Ambient temp. 0°C	23.6	2.30 (5)	46.8	12.87 (5)
Ambient temp. +30°C	12.3	2.20 (5)	36.4	1.14 (5)

Nominal parameters:-

Tension in booms — 600 N

Preload ————— 1100 N

Over-centre angle — 8°

Power input ————— 11 Watts

TABLE 2
CHARACTERISTICS OF THE RELEASE MECHANISM

ACKNOWLEDGEMENTS

The work was supported by an E.S.A. contract and the authors gladly acknowledge the permission of the Director of E.S.A. to publish this paper.

They also wish to acknowledge the contribution of their colleagues, Dr. W. H. Bowyer and Mr. J. M. Cook to the experimental work.