

N79-19029

Paper No. 20

**QUARTZ CRYSTAL MICROBALANCE (QCM) MONITOR
OF CONTAMINATION FOR LES-8/9**John T. Lynch, *MIT, Lincoln Laboratory, Lexington, MA***ABSTRACT**

A Quartz Crystal Microbalance (QCM) was used to monitor condensable contamination during the launching of two Lincoln Laboratory Experimental Satellites--LES-8 and LES-9. The QCM was installed on the dispenser truss and measured contamination by means of a frequency shift of a quartz crystal oscillator. By using a special crystal cut and a second reference quartz crystal, the sensor had extreme sensitivity and remarkable temperature independence. A 1-Hz frequency shift, which corresponds to 3.5×10^{-5} g/cm², was resolved by the flight instrumentation.

A Titan III-C launched LES-8/9 into orbit on 14 March 1976. From time of ignition to injection into orbit, the QCM functioned as anticipated. An enormous change in QCM frequency (1062 Hz, corresponding to $3.7 \mu\text{g}/\text{cm}^2$) occurred at the time of the firing of the retro-rockets which separate the spent Stage II. A significant but much smaller change occurred during the 200-second period following payload fairing jettison.

INTRODUCTION

Lincoln Laboratory designed and built two satellites, LES-8/9, which were launched into synchronous orbit from the Eastern Test Range at Cape Canaveral, Florida on 14 March 1976. Careful examination and control of contamination were exercised during the fabrication, testing, and launching of the satellites. A wide variety of techniques were used to monitor contamination during these various phases including monitors which measured accumulated contamination from liftoff through injection into synchronous orbit. This paper describes the technique used and the results obtained in monitoring contamination during the launching of the satellites.

PRECEDING PAGE BLANK NOT FILMED

The launch contamination monitor was a Quartz Crystal Microbalance (QCM) which was installed on the dispenser truss of the satellites. The QCM measured contamination by means of a frequency shift of a quartz crystal oscillator which occurs when the crystal mass increases as a result of contamination loading. The device is extremely sensitive, 1 Hz corresponding to 3.5×10^{-9} g/cm². This sensitivity is achieved by using a special crystal cut which produces small temperature dependence and by using a second reference quartz crystal the signal from which, when mixed with the signal from the sensing crystal, gives a beat frequency remarkably independent of temperature and power supply fluctuations.

Analog signals proportional to the QCM beat frequency were read out by the launch vehicle (Titan III-C) telemetry system. The telemetry signals were recorded at various ground stations and processed subsequently to give QCM frequency as a function of time. The QCM frequency was measured once every two seconds. It is therefore possible to associate contamination buildup with specific events during the launch sequence.

SYSTEM CONSIDERATIONS

The Quartz Crystal Microbalance (QCM) responds to contamination which couples to the thickness-shear oscillation in the crystal. This coupling is strong for thin films or residues whose thickness is very small relative to the crystal thickness. The coupling is weak for large particulate contamination, i.e., dust.

Outgassed contaminants are called volatile condensable materials (VCM). An example of the contamination process is the evaporation of low-molecular-weight material (i.e., volatile) from a painted surface which is hot as a result of solar illumination. The low-molecular-weight material then condenses on a cooler surface which may be shaded from the sun.

The sensitivity requirement for the QCM contamination monitor is that mass densities which are a fraction of 0.1 $\mu\text{g}/\text{cm}^2$ be measurable. It was therefore determined that uncertainties in the QCM frequency should be less than ± 3 Hz. The QCM readout and telemetry had a precision of 1 Hz, which permits fine-scale measurements of temperature-induced variations, etc. To give physical meaning to these numbers the mass density of various thin films and a droplet type of contamination have been calculated in Table I.

Because the external satellite surfaces are near the Payload Fairing (PLF), the QCM had to be placed near the PLF at the same height as the satellites.

The dispenser truss was therefore ideally suited. The most probable sources of contamination were retro-rocket exhaust products and ablation products from the retro-rocket impingement pads on Stage II. Figure 1 shows the placement of the QCM relative to LES-8/9 and the upper stages of the Titan III-C. The QCM is directly in line with one of three retro-rockets. Figure 2 which details the payload region more clearly shows the dispenser truss mounting arrangement. The QCM is pointed at an angle of 25° from the vertical so that it has a direct view of the retro-plume and still has some sensitivity to contamination coming directly into the payload region from the side.

TABLE I
Mass Density of Films of Stearic Acid
CH₃ (CH₂)₁₀ COCH and of Water H₂O

<u>Thickness</u>	<u>Mass Density</u>	<u>QCM Frequency</u>
Stearic Acid		
2.1 nm (monolayer)	0.18 µg/cm ²	51 Hz
100 nm smooth film	8.5 µg/cm ²	2430 Hz
Water		
0.4 nm (monolayer)	0.04 µg/cm ²	11 Hz
1 µm radius half-spherical droplets covering 1.0% of surface	0.66 µg/cm ²	189 Hz

INSTRUMENTATION

The QCM flown on the LES-8/9 dispenser truss was procured from Faraday Laboratories, La Jolla, California. The QCM was of a design similar to that used on the NASA OGO-6 satellite (Ref. 1, 2). The sensor consists of two quartz crystals each of which resonates at approximately 10 MHz. The sensing crystal is displaced in frequency approximately 1 kHz below the reference crystal. The output of a mixer circuit provides a beat frequency which increases when the sensing crystal is contaminated.

The QCM is a modification of a single-crystal device commonly used to measure the thickness of vacuum-deposited thin films. The AT cut of the crystal has a minimum temperature coefficient with frequency and is used for all thickness monitors. The

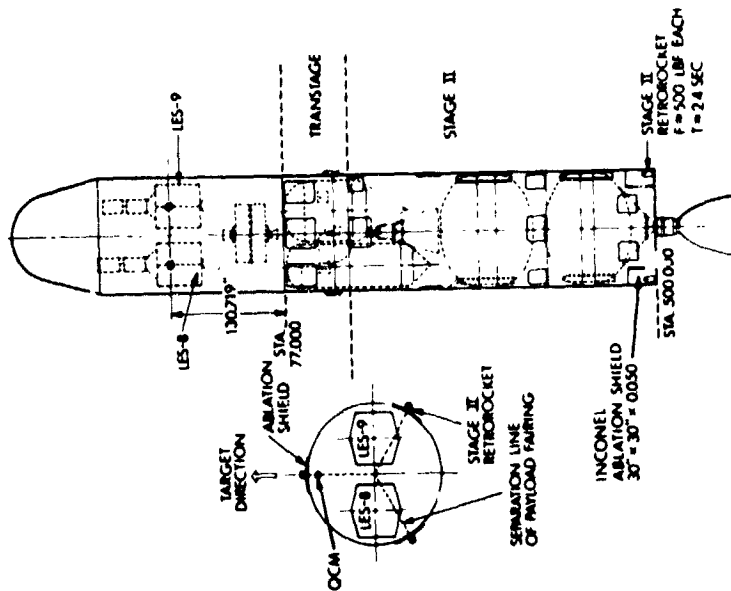

UPPER STAGES OF TITAN III-C FOR P74-1 MISSION

FIGURE 1

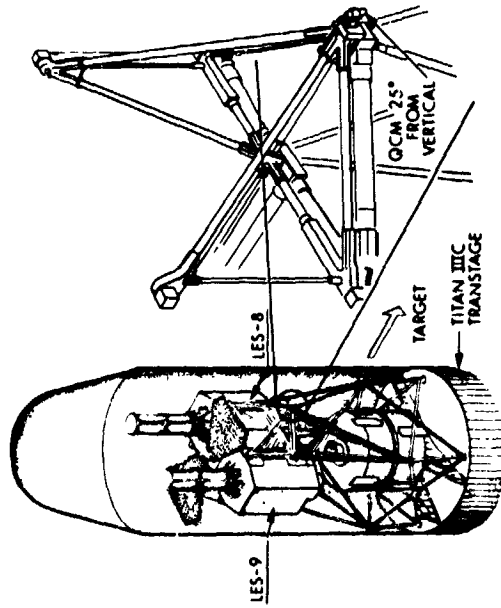

QCM LOCATION ON DISPENSER

FIGURE 2

contamination sensor achieves immunity to power supply fluctuations and further immunity to temperature changes by using two crystals selected by careful measurement to have nearly identical temperature vs. frequency characteristics.

A photograph of the QCM in various stages of disassembly is shown in Fig. 3. The QCM has the feature that the crystal head is removable and replaceable.

Shown in the figure are:

1. assembled unit (head plus oscillator electronics),
2. unit with head removed, and
3. head disassembled (crystal visible).

A diagram of the sensor body and head is shown in Fig. 4.

EXPERIMENTAL RESULTS

The QCM functioned as expected from installation to satellite separation, which marked the end of the experiment. Readings made prior to launch indicate negligible changes in frequency (less than ± 2 Hz) during this period. From launch vehicle ignition until payload separation some seven hours later, launch vehicle telemetry was recorded during specific "telemetry windows". Digital QCM data have been received and reduced for those available time periods of interest.

A plot of the QCM frequency vs. time for the entire launch is shown in Fig. 5. This plot is linear in frequency change (hence, linear in contamination). Note the gaps in the time axis so that the full 24,000 seconds could be displayed as well as the critical first 600 seconds. An enormous amount of contamination was measured at the time of the retro-rocket firing. The change was 1062Hz, or 3.7×10^{-6} gm/cm² or 3.4 mg/ft². Another significant change, although minor by comparison to the retro-rocket contamination occurred during the time interval following PLF jettison. Other time periods for which data are available show small frequency changes, generally less than ± 10 Hz ($\pm 3.5 \times 10^{-8}$ gm/cm²). The temperature of the sensor head was about 31°C (88°F) at the time of ignition and dropped only 1°C during the following 7-hour period.

A plot of the QCM frequency vs. time for the first 300 seconds following ignition (part of telemetry window I) is shown in Fig. 6. A greatly expanded frequency axis is used to see better the minor frequency changes.

A plot of the QCM frequency vs. time for the interval from PLF jettison to a time just prior to the

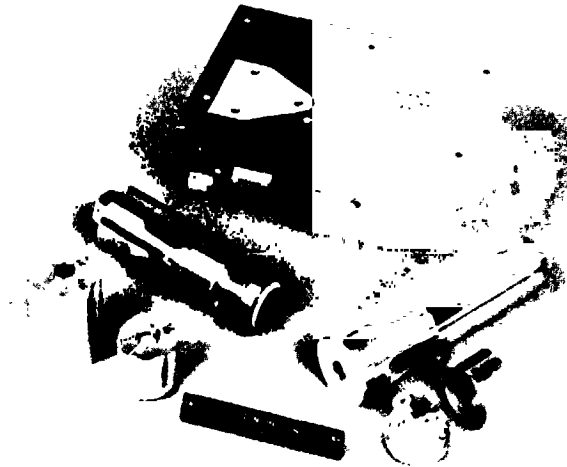

PHOTOGRAPH OF QCM IN VARIOUS STAGES OF DISASSEMBLY
 FIGURE 3

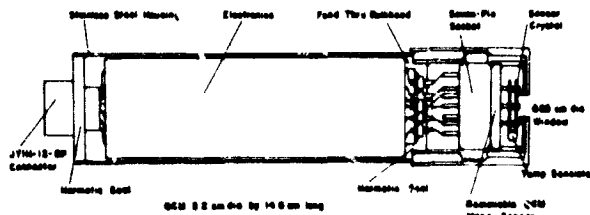
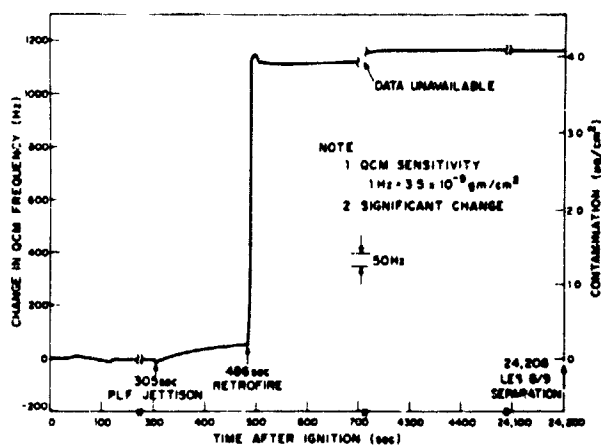

DIAGRAM OF QCM
 FIGURE 4

ORIGINAL PAGE IS
 OF POOR QUALITY

ORIGINAL PAGE IS
OF POOR QUALITY



QCM FREQUENCY VS. TIME FOR ENTIRE LAUNCH
FIGURE 5

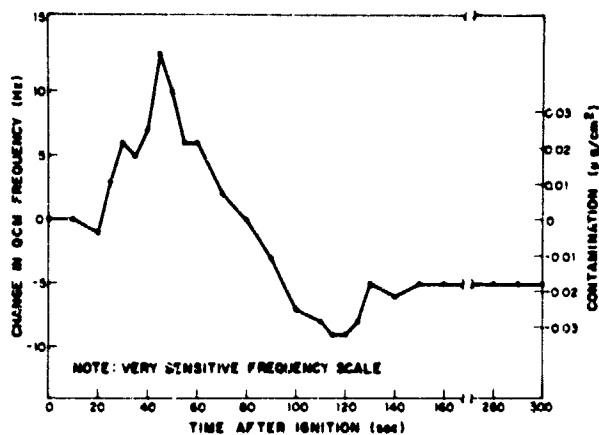

QCM FREQUENCY VS. TIME: IGNITION TO PLF JETTISON
FIGURE 6

firing of the Stage-II retro-rockets is shown in Fig. 7. The linear frequency and time axes were selected to display clearly the gradual 65 Hz change which occurs over the 200 second time interval. The contamination may be due to molecular scattering of satellite desorbed molecules by ambient gas molecules in the low earth orbit (Ref. 3). The change in QCM frequency due to a change in QCM package temperature or a change in sensor crystal temperature due to a change in radiative background (e.g., $\sim 350^\circ \text{LF}$ to $\sim 0^\circ \text{K}$ deep space) has been bounded by ± 1 Hz.

The next available data following Window I is Window IV, which includes 4210 sec. to 4658 sec. after ignition. The QCM frequency vs. time is plotted for this time interval in Fig. 8. Also indicated is the last QCM reading for Window I and the reading for Window XI (24,000 sec). The reading from 24,030 sec. to 24,208 sec. change by only ± 1 Hz. The 35 Hz increase in QCM frequency which occurs from the end of Window I to the beginning of Window IV could be due to parking orbit contamination or could be due to heating of the sensing crystal relative to the reference crystal as a result of direct solar illumination.

CONCLUSION

The QCM had little opportunity to be contaminated by direct line-of-sight sources. The two contamination events measured by the QCM during the Titan III-C launch were from indirect, non-line-of-sight sources. The major conclusion to be drawn from the measurements reported here is that these indirect contamination mechanisms, which presumably result from interaction of the contaminant molecules with each other, with ambient molecules, or perhaps interaction with static electric fields, can definitely be significant.

REFERENCES

1. D. McKeown, W. E. Conlin, Jr., "Space Measurements of the Contamination of Surfaces by OGO-6 Outgassing and Their Cleaning by Sputtering and Desorption," NBS Special Publication 336, Paper No. 7, pp. 113-127, October 1970.
2. D. McKeown and R. S. Dummer, "Gas-Surface Energy Transfer Experiment for OGO-F," IEEF. Trans. on Geoscience Electronics, Vol. GE-7, No. 2, pp. 98-106 April 19 9.
3. R. L. Harvey, "Spacecraft Self-Contamination by Molecular Outgassing," Technical Note 1975-1, Lincoln Laboratory, M.I.T. (31 March 1975).

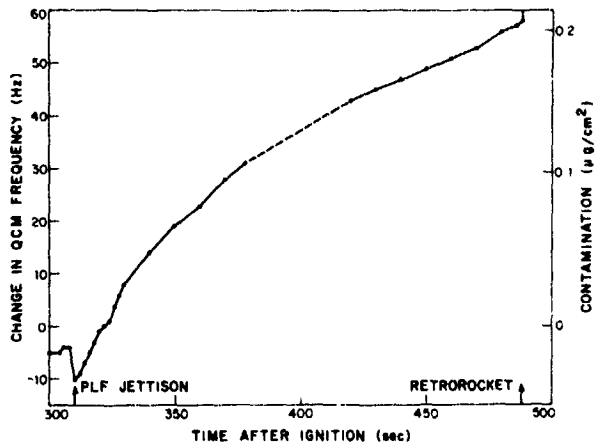

QCM FREQUENCY VS. TIME: PLF JETTISON TO STAGE II RETRO

FIGURE 7

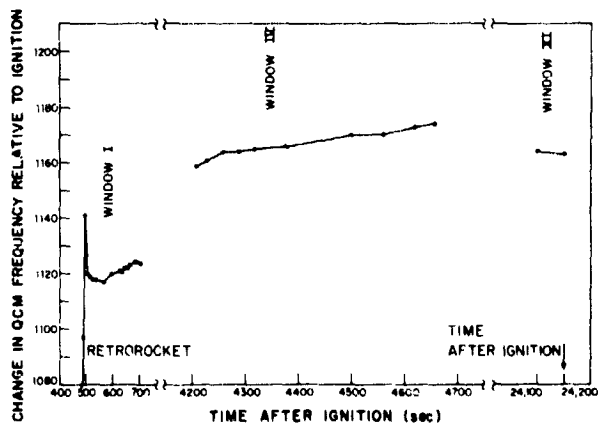

QCM FREQUENCY VS. TIME FOR WINDOW IV, XI, AND END OF I

FIGURE 8